

[home](#)

THE NAVAL BALANCE 1950

Navies of the world

01/01/1950

1. USA - 9870 tt; 2. United Kingdom - 2086 tt; 3. Soviet Union - 612 tt; 4. France - 397 tt; 5. Canada - 188 tt; 6. Argentina - 174 tt; 7. Italy - 169 tt; 8. Australia - 165 tt; 9. Spain - 137 tt; 10. Sweden - 103 tt



[ALBANIA](#)

[ARGENTINA](#)

[AUSTRALIA](#)

[BELGIUM](#)

[BRAZIL](#)

[BULGARIA](#)

[BURMA](#)

[CANADA](#)

[CEYLON](#)

[CHILE](#)

[CHINA](#)

[COLOMBIA](#)

[CUBA](#)

[CZECHOSLOVAKIA](#)

[DENMARK](#)

[DOMINICAN REPUBLIC](#)

[ECUADOR](#)

[EGYPT](#)

[FINLAND](#)

[FRANCE](#)

[GREECE](#)

[HAITI](#)

[HONG KONG](#)

[HUNGARY](#)

[ICELAND](#)

[INDIA](#)

[INDONESIA](#)

[IRAN](#)

[IRAQ](#)

[IRELAND](#)

[ISRAEL](#)

[ITALY](#)

[JAPAN](#)

[KOREA, NORTH](#)

[KOREA, SOUTH](#)

[MALAYSIA](#)

[MEXICO](#)

[NETHERLANDS](#)

[NEW ZEALAND](#)

[NICARAGUA](#)

[NORWAY](#)

[PAKISTAN](#)

[PARAGUAY](#)

[PERU](#)

[PHILIPPINES](#)

[POLAND](#)

[PORTUGAL](#)

[ROMANIA](#)

[SOUTH AFRICA](#)

[SOVIET UNION](#)

[SPAIN](#)

[SWEDEN](#)

[SYRIA](#)

[TAIWAN](#)

[THAILAND](#)

[TURKEY](#)

[UNITED KINGDOM](#)

[UNITED STATES OF AMERICA](#)

[URUGUAY](#)

[VENEZUELA](#)

[YUGOSLAVIA](#)

1576530

[Website Hit Counter](#)

© Ivan Gogin, 2015-16

[home](#)[World navies yesterday](#)[1950](#)

Albania 01 January 1950

PATROL AND COASTAL COMBATANTS

PB	Tirana	2	1, 2		1926	No picture	46t, 24.4xxm, 2d, 450hp, 17kts; 1x1-76/40
----	--------	---	------	--	------	------------	---

AMPHIBIOUS

LSS	MFP	2	1	1943		239t, 49.8x6.6x1.4m, 3d, 375hp, 10.5kts, 21p; 1x1-75/35, 4x1-20/65; 3tanks
			2	1943		

MINE WARFARE

MSB	KM4	2	1, 2		1943-45		12t, 19.3x3.4x0.8m, 2pe, 126hp, 10kts, 10p; mechanical minesweeping gear
-----	-----	---	------	--	---------	---	--

© Ivan Gogin, 2016



[home](#)[World navies yesterday](#)[1950](#)

Argentina 01 January 1950

SUBMARINES

SS	Santa Fe	3	S1	Santa Fe	1933		935/1155t, 69.2x6.7x5.1m, 2d/em, 3000/1400hp, 17.5/9kts, 40p, 80m; 1x1-102/40, 1x1-40/60, 8-533TT
			S2	Santiago del Estero	1933		
			S3	Salta	1933		

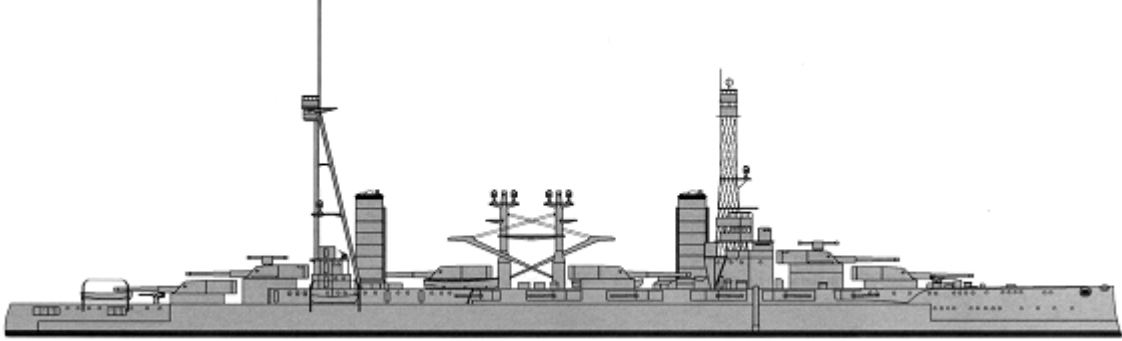

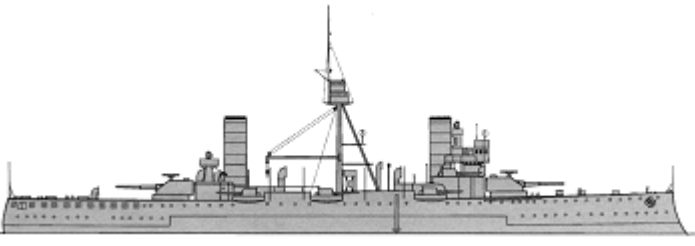
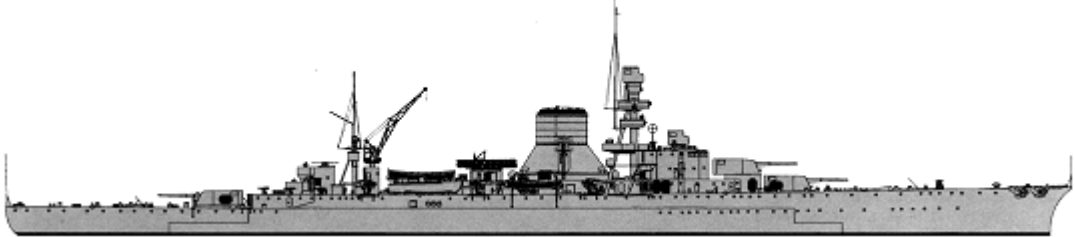
PRINCIPAL SURFACE COMBATANTS

BB	Rivadavia	1	1	Rivadavia	1914		30600t, 181.3x30.0x8.5m, 18b,3gst, 45000hp, 20kts, 1130p; 280belt, 114deck, 305turrets, 305CT; 6x2-305/50, 12x1-152/50, 4x1-76/50, 4x1-40/60, 2-533TT
BC	9 de Julio	1	1	Independencia	1892		2595t, 70.1ppx13.1x4.0m, 4b,2vte, 2800hp, 14kts, 230p; steel-203belt, 37deck, 203barbettes, 102CT; 2x1-238/35, 4x1-120/41, 4x1-40/39
CA	Garibaldi	1	1	Pueyrredon	1898		6775t, 111.7x18.2x7.1m, 8b,2vte, 13000hp, 17kts, 500p; 150belt, 37deck, 150turrets, 150CT; 2x1-254/40, 8x1-152/40, 2x1-57/40
	Almirante Brown	2	C1	Almirante Brown	1931		9000t, 170.8x17.8x4.7m, 6b,2gst, 85000hp, 32kts, 780p; 70belt, 25deck, 50turrets, 65CT; 3x2-190/52, 6x1-102/45, 6x1-40/39, 6-533TT, 2seaplanes (Walrus); type 268 radar
	C2		25 de Mayo	1931			

CL	La Argentina	1	C3	La Argentina	1939		8500t, 164.9x17.2x5.0m, 4b,4gst, 54000hp, 30kts, 800p; 76belt, 51deck, 51turrets, 76CT; 3x3-152/50, (4x2+6x1)-40/60, 2x3-533TT; type 268, Mk8 radars
DD	Catamarca	2	D1	Catamarca	1912		1357t, 88.1x8.3x2.6m, 5b,2st, 24000hp, 32kts, 150p; 3x1-102/50, 2x1-37/43, 2x2-533TT, 1dct
			D2	Jujuy	1912		
	Córdoba	2	D2	Córdoba	1912		1368t, 90.0x9.0x2.8m, 5b,2st, 24000hp, 32kts, 150p; 3x1-102/50, 2x1-37/43, 2x2-533TT, 1dct
			D4	La Plata	1912		
	Cervantes	2	T1	Cervantes	1927		2087t, 101.5x9.7x3.7m, 4b,2gst, 42000hp, 36kts, 175p; 4x1-120/45, 3x2-40/60, 2x3-533TT, 2dcr
			T2	Juan de Garay	1927		
	Mendoza	3	T3	Mendoza	1929		2120t, 102.1x9.7x3.8m, 4b,2gst, 42000hp, 36kts, 160p; 4x1-120/45, 3x2-40/60, 2x1-40/39, 2x3-533TT
			T4	La Rioja	1929		
			T5	Tucumán	1929		
	Buenos Aires	6	T6	Buenos Aires	1938		2010t, 98.5x10.6x3.2m, 3b,2gst, 34000hp, 35.5kts, 130p; 4x1-120/45, 2x4-12.7, 2x4-533TT
			T7	Entre Ríos	1938		
			T9	San Juan	1938		
T10			San Luis	1938			
T11			Misiones	1938			
T12	Santa Cruz	1938					
FF	Ashville	1	P31	Hércules	1942		2150t, 91.9x11.1x4.0m, 2b,2vte, 5500hp, 20kts, 190p; 3x1-105/45, (2x2+2x1)-40/60, 1x24-178 Hedgehog ASWRL, 8dct, 2dcr; SA, SU, Mk26 radars, sonar
	Tacoma	3	P32	Heroína	1944		2238t, 92.6x11.4x3.9m, 3b,2vte, 5500hp, 20kts, 190p; 3x1-105/45(32,34), 2x1-105/45(33), (2x2+4x1)-40/60, 1x24-178 Hedgehog ASWRL, 8dct, 2dcr; SA, SU, Mk26 radars, sonar
			P33	Sarandí	1944		
			P34	Trinidad	1943		

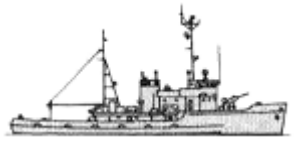
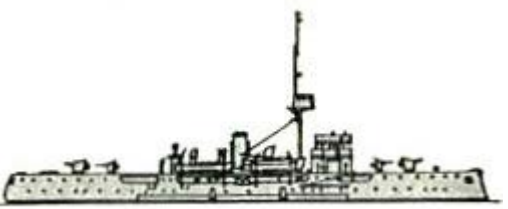

FS	Murature	2	P20	Murature	1945		1032t, 76.8x8.8x2.3m, 2d, 2500hp, 18kts, 130p; 3x1-105/45, (1x2+2x1)-40/60, 2x1-12.7, 4dct
			P21	King	1946		
	Flower	1	P10	República	1943		1370t, 63.5x10.1x4.4m, 2b,1vte, 2750hp, 16.5kts, 109p; 1x1-105/45, 4x1-20/70, 4dct, 2dcr; type 268, 276 radars, sonar

PATROL AND COASTAL COMBATANTS

PC	Sotoyomo	2	1	Yamana	1943		835t, 43.6x10.3x4.0m, 2dg, 2em, 1500hp, 13kts, 49p; 1x1-40/60, 2x1-20/70; Decca 1226 radar
			2	Sanaviron	1947		
PR	Rosario	2	1	Rosario	1909		1055t, 76.4x9.8x2.1m, 2b,2vte, 1300hp, 14.5kts, 145p; 76belt, 25deck, 76CT; 2x1-152/13, 6x1-76/40, 4x1-40/39
			2	Paraná	1909		
PT	LT1	10	P80 - 89	LT1 - 10	1948		50t, 23.8x6.4x1.5m, 3pe, 4500hp, 42kts, 10p; 2x1-40/60, 4-533TC; SO radar
PB	Dorado	1	1	Dorado	1939	No picture	43t, 21.2x4.3x1.5m, 2d, 360hp, 12kts, 7p

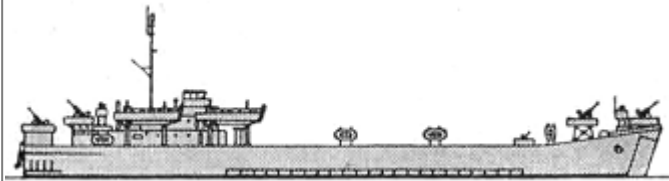
AMPHIBIOUS

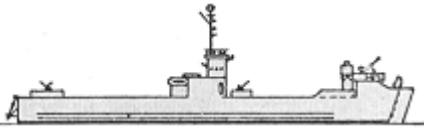
LST	LST(2)	13	Q41	BDT1	1945		4080t, 100.0x15.2x4.3m, 2d, 1800hp, 12.1kts, 125p; 20tanks, 163troops; radar
			Q42	BDT2	1944		
			Q43	BDT3	1944		
			Q44	BDT4	1945		
			Q45	BDT5	1944		
			Q46	BDT6	1944		
			Q47	BDT7	1944		
			Q48	BDT8	1945		
			Q49	BDT9	1945		
			Q50	BDT10	1945		
			Q51	BDT11	1945		
			Q52	BDT12	1945		
			Q54	BDT14	1944		
LSM	LSM1	2	Q69	BDM1	1944		1095t, 62.0x10.5x2.1m, 2d, 2800hp, 12.5kts, 60p; 1x2-40/60, 4x1-20/70; 5tanks, 54troops
			Q70	BDM2	1944		

							
LCU	LCI(L)	14	Q54	BDI1	1944		385t, 48.9x7.2x1.6m, 8d(2), 2320hp, 15.5kts, 29p; 5x1-20/70; 209troops; SCR-517A radar
			Q55	BDI2	1944		
			Q56	BDI3	1944		
			Q57	BDI4	1944		
			Q58	BDI5	1944		
			Q59	BDI6	1944		
			Q60	BDI7	1944		
			Q62	BDI9	1944		
			Q63	BDI10	1944		
			Q64	BDI11	1944		
			Q65	BDI12	1944		
			Q66	BDI13	1944		
			Q67	BDI14	1944		
			Q68	BDI15	1944		
LC	LCVP	22	1 - 22	EDVP1 - 22	1943 - 1945		13t, 11.2x3.2x0.9m, 2d, 220-450hp, 8kts, 3p; 2x1-12.7; 36troops

MINE WARFARE SHIPS

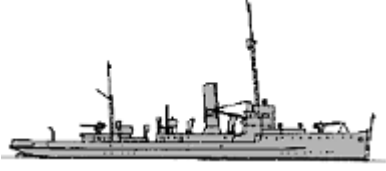
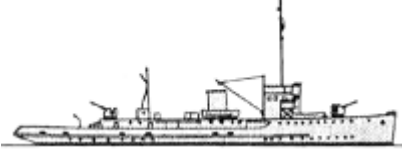
MSO	1916	2	M6	Pinedo	1919		548-553t, 59.3x7.3-7.4x2.2m, 2b,2vte, 1850hp, 16.3kts, 40p; 3x1-76/46, 30mines, sweeps
			M8	Seguí	1918		
MSO	Bouchard	8	M2	Drummond	1937		520t, 59.0x7.3x2.3m, 2d, 2000hp, 15kts, 62p; 2x1-102/50, 2x1-40/39, sweeps
			M3	Robinson	1939		
			M4	Granville	1937		
			M7	Bouchard	1937		
			M10	Py	1939		
			M11	Parker	1938		
			M12	Seaver	1939		
			M13	Spiro	1938		

[home](#)

[World navies yesterday](#)



[1950](#)

Australia 01 January 1950

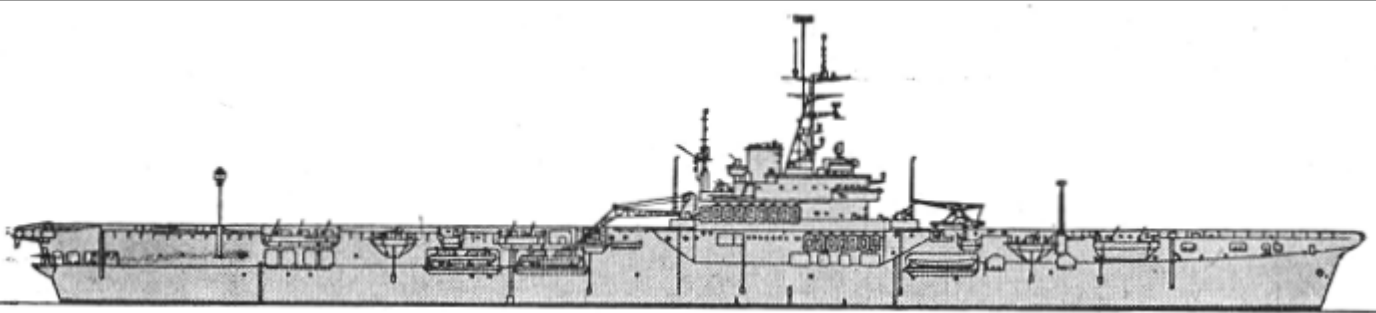
AIRCRAFT CARRIERS

CVL	Magnificent	1	R17	Sydney	1949		<p>17780t, 211.8x24.4x7.0m, 4b,2gst, 40000hp, 25kts, 1300p; (6x2+18x1)-40/60, 26aircraft (Sea Fury, Firefly fighters); 2x type 277Q, 293M, 960/281BQ, 961 radars</p>
-----	-------------	---	-----	--------	------	--	--

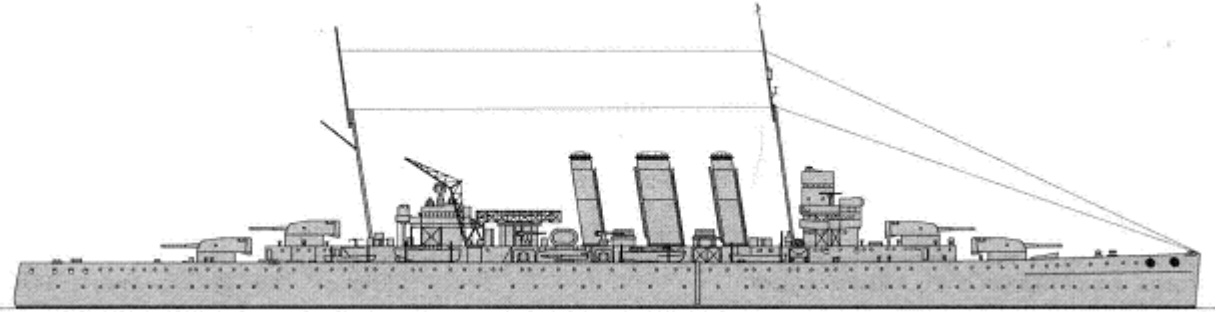
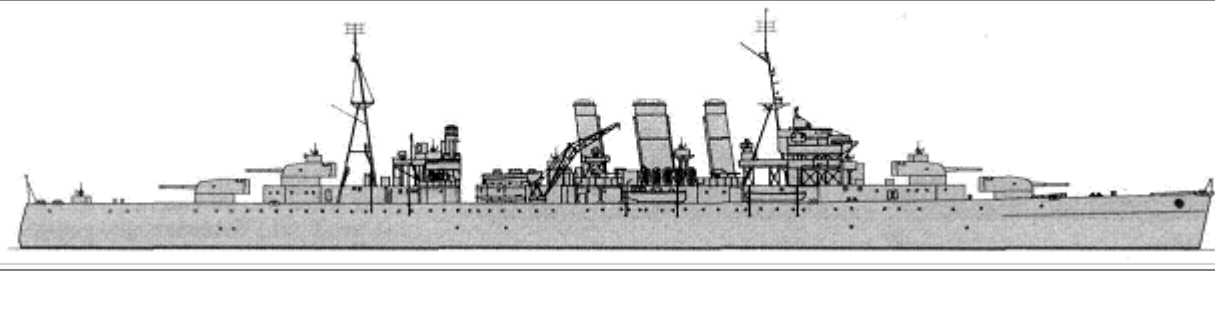
PRINCIPAL SURFACE COMBATANTS

CA	Australia	1	1	Australia	1928		<p>14910t, 192.9x20.8x6.9m, 8b,4gst, 80000hp, 31.5kts, 710p; 114belt, 38deck, 25turrets; 3x2-203/50, 4x2-102/45, 4x1-47/40, (2x4+2x2+2x1)-40/60, 4x8-40/39; type 273, 281, 284, 285 radars</p>
	Shropshire	1	83	Shropshire	1929		<p>14580t, 192.9x20.1x6.9m, 8b,4gst, 80000hp, 32.3kts, 700p; 25belt, 38deck, 25turrets; 4x2-203/50, 4x2-102/45, 7x1-40/60, 2x8-40/39, 2x4-533TT; type 273, 277, 281, 282, 285 radars</p>
CL	Amphion	1	1	Hobart	1936		<p>9420t, 171.4x17.3x6.0m, 4b,4gst, 72000hp, 32.5kts, 570p; 76belt, 51deck, 25turrets; 3x2-152/50, 4x2-102/45, (2x4+3x2+5x1)-40/60, 2x4-40/39, (1x2+2x1)-20/70, 2x4-533TT; type 276, 277, 281B, 282, 283, 285, SG-1, Mk3 radars</p>

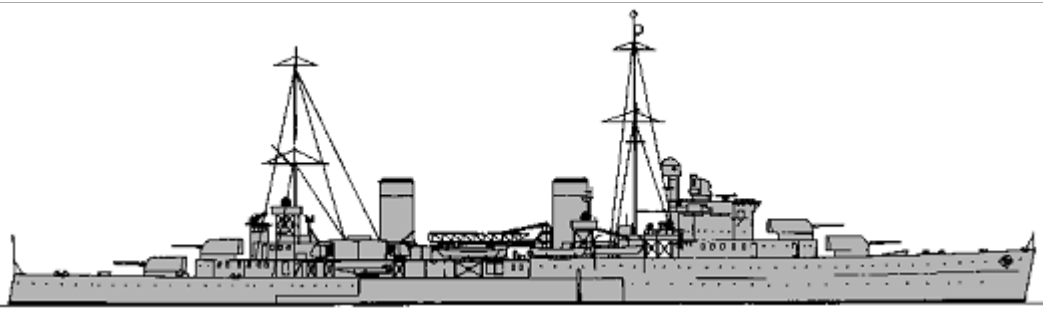
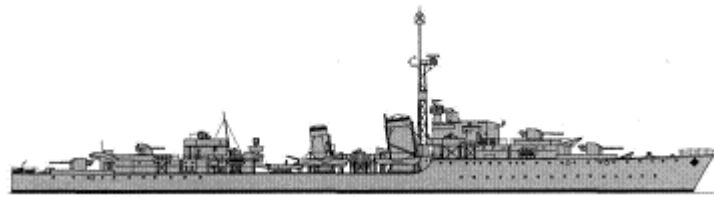
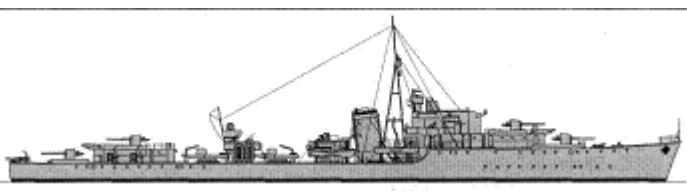
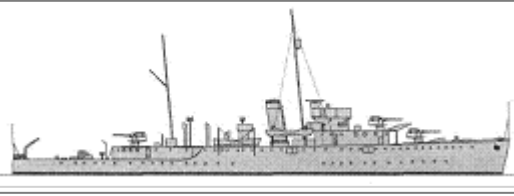
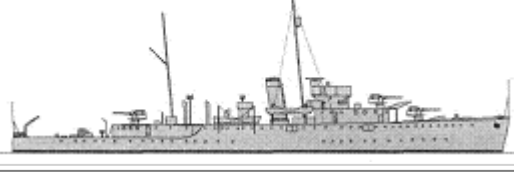
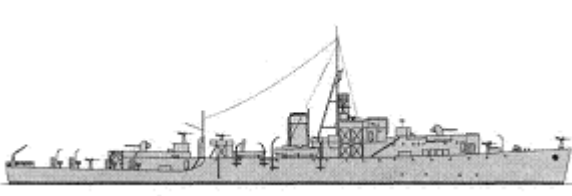
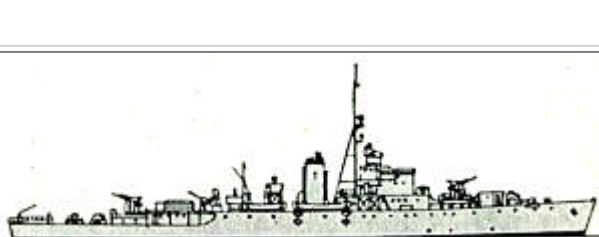
								
DD	Tribal	3	I30	Arunta	1942		2710t, 114.9x11.1x4.2m, 3b,2gst, 44000hp, 36.2kts, 250p; 3x2-120/45, 1x2-102/45, 6x1-40/60, 1x4-40/39, 1x4-533TT, 2dct, 2dcr; type 272, 275, 291 radars, type 127 sonar	
			I44	Warramunga	1942			
			I91	Bataan	1945			
	Q	5	G11	Quadrant	1942		2480t, 109.2x10.9x4.3m, 2b,2gst, 40000hp, 36.7kts, 225p; 4x1-120/45, 1x4-40/39, (2x2+4x1)-20/70, 2x4-533TT, 4dct, 3dcr; type 272, 282, 285, 291 radars, type 123A, 127 sonars	
			G62	Quality	1942			
			G70	Queenborough	1942			
			G81	Quiberon	1942			
			G92	Quickmatch	1942			
	FF	Swan	1	U74	Swan	1937		1510t, 81.2x11.0x3.1m, 2b,2gst, 2000hp, 16.5kts, 100p; 2x2-102/45, 2x1-20/70, 4dct, 2dcr; sonar
		Parramatta	1	U73	Warrego	1940		1510t, 81.2x11.0x3.1m, 2b,2gst, 2200hp, 16.8kts, 100p; 2x2-102/45, 2x1-20/70, 4dct, 2dcr; sonar
River		7	K354	Gascoyne	1943		2180t, 91.8x11.2x3.9m, 2b,2vte, 5500hp, 20kts, 140p; 2x1-102/45(354,376,377,406), 1x2-102/45(363,375,532), 3x1-40/60(377,406), 1x1-40/60(363,375), (2x2+4x1)-20/70(354,376), 1x24-178 Hedgehog ASWRL(354,376,377,406), 2x3-305 Squid ASWRL(363,375,532), 8dct, 2dcr; type 272, 275(363,375), 291 radars, sonars	
			K363	Hawkesbury	1944			
			K375	Barcoo	1944			
			K376	Burdekin	1944			
			K377	Diamantina	1945			
			K406	Barwon	1946			
			K532	Macquarie	1945			
River modified		4	K408	Culgoa	1947		2187t, 91.7x11.1x3.9m, 2b,2vte, 5500hp, 19kts, 177p; 2x2-102/45, 3x1-40/60(442), 5x1-40/60(408,535,698), 1x24-178 Hedgehog ASWRL, 4dct, 2dcr; type 275, 277, 291 radars, sonars	
	K442		Murchison	1945				
	K535		Shoalhaven	1946				
	K698		Condamine	1946				

PATROL AND COASTAL COMBATANTS

PB	HDML	9	1-9	ML1321-1329	1943 - 1945		54t, 22.0x4.8x1.4m, 2d, 300hp, 11.5kts, 10p; 2x1-20/70, 8dc; type 291 radar
----	------	---	-----	-------------	-------------	---	---

AMPHIBIOUS

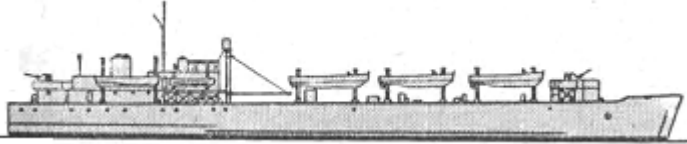
LST	LST(3)	6	L3008	LST3008	1945		4980t, 105.9x16.8x3.8m, 2b,2vte, 5500hp, 13.5kts, 111p; 2x2-40/60, (2x2+2x1)-20/70; 5 LCA, 1 LCT(6), 15 tanks, 170 troops
			L3014	LST3014	1945		
			L3017	Tarakan	1945		
			L3022	LST3022	1945		
			L3035	Lae	1945		
			L3501	Labuan	1945		
LPA	LSI(L)	1	1	Westralia	1929		8108t, 136.6x18.4x6.9m, 2d, 10000hp, 15.5kts; 3x1-102/40; ? LCA/LCS(M)/LCM, 933 troops

MINE WARFARE SHIPS

MSO	Bathurst	32	K34	Ararat	1943		790t, 56.7x9.5x3.0m, 2b,2vte, 1550-2000hp, 15-16kts, 90p; 1x1-102/45, 1x1-40/60, 2x1-20/70, 4dct, 2dcr, sweeps; radar, sonar
			J203	Rockhampton	1942		
			J204	Katoomba	1941		
			J205	Townsville	1941		
			J206	Lithgow	1941		
			J207	Mildura	1941		
			J218	Kapunda	1942		
			J231	Bundaberg	1942		
			J232	Deloraine	1941		
			J233	Inverell	1942		
			J234	Latrobe	1942		
			J235	Horsham	1942		
			J236	Glenelg	1942		
			J238	Gympie	1942		
			J241	Bunbury	1943		
			J242	Colac	1942		
			J244	Castlemaine	1942		
			J246	Fremantle	1943		
			J248	Shepparton	1943		
			J251	Dubbo	1942		
J252	Echuca	1942					
J285	Bowen	1942					
J315	Wagga	1942					
J316	Cootamundra	1943					
J323	Benalla	1943					
J324	Gladstone	1943					

J348	Stawell	1943
J351	Cowra	1943
J353	Kiama	1944
J361	Parkes	1944
J362	Junee	1944
J363	Strahan	1944

© Ivan Gogin, 2015

[home](#)[World navies yesterday](#)[1950](#)

Belgium 01 January 1950

PRINCIPAL SURFACE COMBATANTS

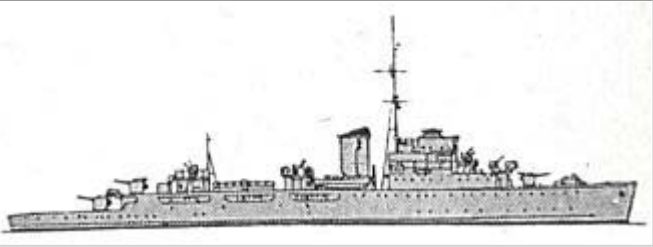
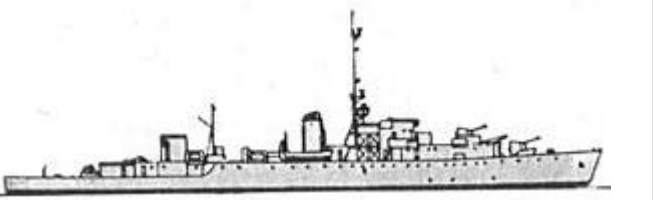
FF	Artevelde	1		Artevelde	1943		2306t, 98.5x10.5x3.8m, 2b,2gst, 21700hp, 28.5kts, 180p; 3x1-105/45, 2x1-40/60, 1x2-37/83, 3x4-20/65, 120mines, mechanical sweeps
	Tacoma	1	F910	Lieutenant ter zee Victor Billet	1944		2238t, 92.6x11.4x3.9m, 3b,2vte, 5500hp, 20kts, 180p; 2x1-76/50, 3x2-40/60, 2x1-20/70, 1x24-178 Hedgehog ASWRL, 8dct, 2dcr; SA, SF, Mk26 radars, sonar

PATROL AND COASTAL COMBATANTS

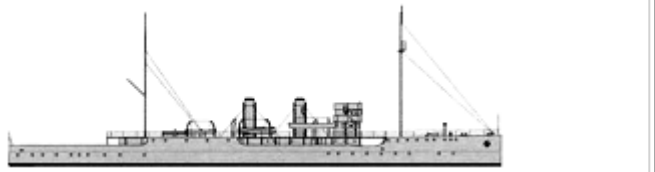
PS	Flower	1	1	Jan Breydel	1915		1275t, 80.0x10.1x3.4m, 2b,1vte, 1400hp, 14kts, 90p; 3x1-105/45, 4x2-37/83, 3x4-20/65
----	--------	---	---	-------------	------	--	--

MINE WARFARE

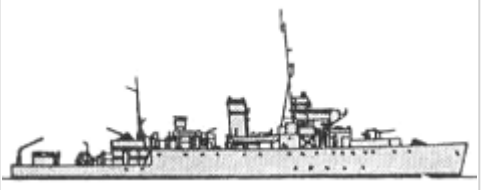
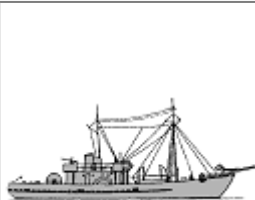
MSO	Algerine	1	1	Adrien de Gerlache	1945		1335t, 68.6x10.8x3.2m, 2b,2gst, 2000hp, 16kts, 101p; 1x1-102/45, 4x1-40/60, 4dct, 2dcr; minesweeping gear; radar, sonar
MSC	MMS1	7					295t, 36.4x7.1x2.7m, 1d, 500hp, 11kts, 20p; 2x1-20/70, mechanical, acoustic, magnetic minesweeping gear
				M182	MMS182	1942	
				M187	MMS187	1942	
				M188	MMS188	1942	
				M189	MMS189	1942	
				M191	MMS191	1942	



		M193	MMS193	1942		
		M226	MMS226	1942		
MMS1001	1	M1020	MMS1020	1944		430t, 42.7x8.5x3.2m, 1d, 500hp, 10kts, 21p; 2x2-20/70, mechanical, acoustic, magnetic minesweeping gear

© Ivan Gogin, 2016



[home](#)[World navies yesterday](#)[1950](#)

Brazil 01 January 1950

SUBMARINES

SS	Humaitá	1	1	Humaitá	1929		1450/1884t, 86.7x7.8x4.3m, 2d/em, 4000/1000hp, 18.5/10kts, 61p, 100m; 1x1-120/41, 2x1-13.2, 6-533TT, 16mines
	Tupi	3	T1	Tupi	1937		674/853t, 60.2x6.5x3.7m, 2d/em, 1400/800hp, 14/7.5kts, 33p, 80m; 1x1-100/47, 2x2-13.2, 6-533TT
T2			Timbira	1937			
T3			Tamoio	1937			

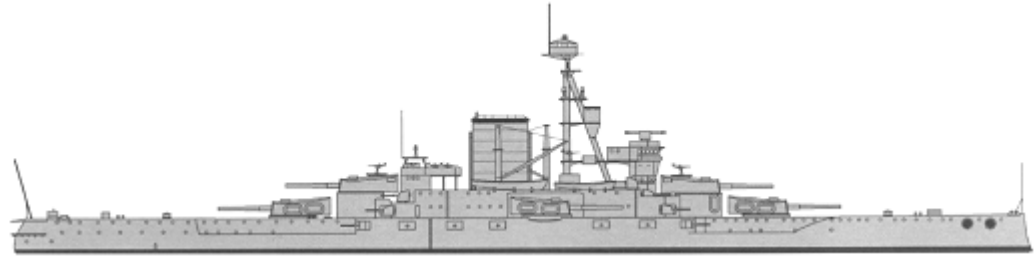
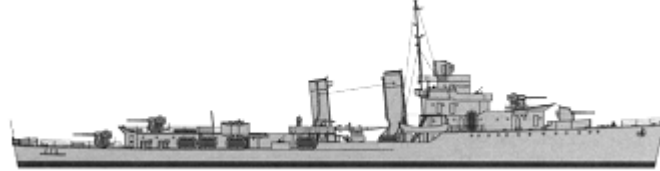



PRINCIPAL SURFACE COMBATANTS

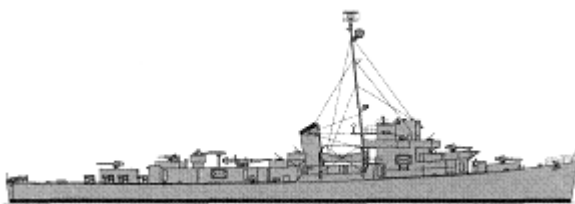

BB	Minas Gerais	1	1	Minas Gerais	1910		21200t, 165.5x25.3x7.6m, 6b,2vte, 30000hp, 22kts, 900p; 229turrets, 305CT; 6x2-305/45, 14x1-120/50, 4x1-102/45, 2x1-76/50, 8x1-37/27, 6x2-20/60
DD	Mariz e Barros	3	M1	Mariz e Barros	1943		2200t, 108.8x10.6x3.0m, 4b,2gst, 42800hp, 36.5kts, 190p; 4x1-127/38, 2x2-40/60, 4x1-20/70, 1x4-533TT, 4dct, 2dcr; sonar
			M2	Marcílio Dias	1943		
			M3	Greenhalgh	1943		
DD	Amazonas	2	A1	Amazonas	1949		1800t, 98.5x10.7x2.6m, 3b,2gst, 45000hp, 36kts, 150p; 4x1-127/38, 1x2-40/60, 4x1-20/70, 2x4-533TT, 2dct, 2dcr; sonar
			A5	Araguaya	1949		
FF	Cannon	8	B1	Bertioga	1943		1602t, 93.3x11.2x3.2m, 4dg, 2em, 6000hp, 21kts, 186p; 3x1-76/50, 1x2-40/60, 8x1-20/70, 1x3-533TT, 1x24-178 Hedgehog ASWRL, 8dct, 2dcr; SA, SU radars, sonar
B2	Beberibe		1943				
B3	Bracuí		1943				
B4	Bauru		1943				
B5	Baependi		1943				

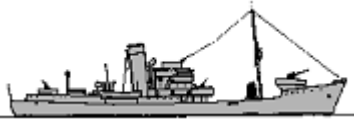
B6	Benavente	1943
B7	Babitonga	1943
B8	Bocaina	1943

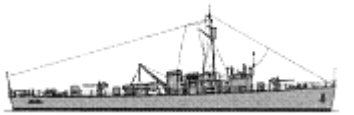

PATROL AND COASTAL COMBATANTS

PCO	Matias de Albuquerque	6	F1	Matias de Albuquerque	1943		920t, 53.8x8.5x4.9m, 1b,1vte, 1000hp, 12.5kts, 70p; 1x1-76/50, 4x1-20/70, 4dct
			F2	Felipe Camarão	1943		
			F3	Henrique Dias	1943		
			F4	Fernandes Vieira	1943		
			F5	Vidal de Negreiros	1944		
			F6	Barreto de Menezes	1944		
	Sotoyomo	3	R1	Tritão	1945		835t, 43.6x10.3x4.0m, 2dg,2em, 1500hp, 13kts, 49p; 1x1-76/50, 2x1-20/70; radar
			R2	Tridente	1945		
			R3	Triunfo	1945		
PC	PC	8	G1	Guaporé	1942		330t, 52.9x7.1x2.4m, 2d, 2880hp, 21kts, 65p; 2x1-76/50(1-4), 1x1-76/50(5-8), 1x1-40/60(5-8), 3x1-20/70, 2x4-178 Mousetrap ASWRL(5-8), 2dct, 2dcr; SCR-517A radar, sonar
			G2	Gurupi	1942		
			G3	Guaíba	1943		
			G4	Gurupá	1943		
			G5	Guajará	1943		
			G6	Goiana	1942		
			G7	Grajaú	1943		
			G8	Graúna	1942		
PS	SC	8	J51	Jutaí	1942		117t, 33.8x5.2x1.9m, 2d, 1000-2400hp, 16-21kts, 27p; 1x1-76/50, 3x1-20/70, 2x4-178 Mousetrap ASWRL, 2dct, 1dcr; SW-1C radar, QC sonar
			J52	Javari	1942		
			J53	Juruá	1942		
			J54	Jaguarão	1942		
			J55	Juruena	1942		
			J56	Jaguaribe	1943		
			J57	Jacuí	1943		
			J58	Jundiaí	1943		
	Rio Pardo	1		Rio Pardo	1945	No picture	132t, 39.0x6.4x1.8m, 3d, 1890hp, 20kts; 3x1-20/70, 2dct, 2dcr
	Parnaíba	1	P2	Parnaíba	1938		720t, 55.0x10.2x1.5m, 2b,2vte, 1300hp, 12kts, 90p; 76belt, 38deck; 1x1-152/50, 2x1-87/13, 2x1-47/40, 4x1-20/70

RMON							
	Paraguassú	1	P3	Paraguassú	1940		600t, 44.7x10.6x1.5m, 2b,2vte, 1100hp, 13kts, 71p; 19belt, 13deck; 1x1-120/50, 2x1-87/13, 2x1-47/40, 4x1-20/70
PGR	-	1	1	Oyapock	1908		295t

MINE WARFARE









MSO	Carioca	5	C1	Carioca	1939		780t, 57.5ppx7.6x2.4m, 2b,2vte, 2200hp, 15kts, 70p; 1x1-102/45(1-3,5), 2x1-76/40(4), 4x1-20/70, 50mines or sweeps
			C2	Cananéia	1939		
			C3	Camocim	1940		
			C4	Cabedelo	1940		
			C5	Caravelas	1940		
MSC	-	1	I3	Itacurussa	1913		280t

© Ivan Gogin, 2015

[home](#)[World navies yesterday](#)[1950](#)

Bulgaria 01 January 1950

PATROL AND COASTAL COMBATANTS

PC	pr.122a	2	281		1941		244t, 48.5x5.8x1.9m, 3d, 3300hp, 23kts, 54p; 1x1-76/55, 2x1-37/73, 3x1-12.7, 2dcr; Tamir-1 sonar
			282		1942		
PT	Druzki	3	1	Druzki	1908		100t, 38.0x4.4x1.3m, 2b,1vte, 1950hp, 26kts, 32p; 2x1-47/50, 1x2-450TT
			2	Khrabri	1908		
			3	Strogi	1909		
	No1	2	2, 3		1939		63(2)-68(3)t, 28.0x4.5x1.5m, 3d, 1905(2)-2850(3)hp, 33(2)-37(3)kts, 19p; 1x1-20/65, 2-533TT, 2dcr, 4mines
	TM52	2	4, 5		1940		38t, 21.4x6.1x1.1m, 3pe, 3300hp, 40kts, 14p; 2x1-20/80, 2-533TT, 2dcr
TD-200bis	4	911-914		1947-48		47t, 23.7x4.7x1.6m, 3d, 3000hp, 38kts, 11p; 2x2-12.7, 2-533TT, Zarnitsa radar	
PB	SC1	2	1	Belomorets	1917		87t, 33.5x4.5x1.7m, 3pe, 660hp, 18kts, 27p; 1x1-37/83, 1x1-20/65
			2	Chernomorets	1918		
	MO-IV	4	21-24		1942-43		57t, 26.9x4.0x1.5m, 2pe, 2000hp, 22kts, 21p; 2x1-45/69, 2x1-20/70, 2dcr
	OD-200	3	61-63		1944		47t, 23.4x4.0x1.8m, 2pe/2pe(2), 2400/170hp, 24kts, 21p; 1x1-37/73, 2x2-12.7, 2dcr
	OD-200bis	3	64-66		1946-47		48t, 23.4x4.0x1.8m, 2d, 2000hp, 29kts, 16p; 1x1-37/73, 2x1-12.7, 2dcr

MINE WARFARE

MSB	Konduktor Dokuzanov	3	1	Balik	1916	No picture	14-18t, 13.0-16.0x2.7-3.0x0.9m, 1pe, 40-60hp, 8-9kts, 5-8p; minesweeping gear
			2	Nesebyr	1916		
			3	Emona	1916		
	MChK	12	2-13		1941-45		25t, 17.3x3.0x1.0m, 1d, 100-120hp, 9-10kts, 8p; minesweeping gear

© Ivan Gogin, 2016



[home](#)[World navies yesterday](#)[1950](#)

Burma 01 January 1950

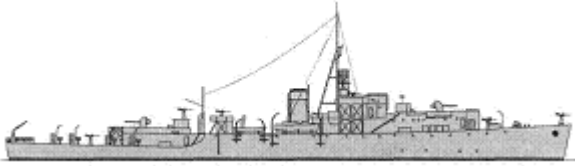
PRINCIPAL SURFACE COMBATANTS

FF	River	1	K266	Mayu	1943		2170t, 91.8x11.2x3.7m, 2b,2vte, 5500hp, 20kts, 140p; 2x1-102/40, 6x1-40/60, 1x24-178 Hedgehog ASWRL, 8dct, 2dcr; type 277, type 291 radars, sonars
----	-------	---	------	------	------	--	--

PATROL AND COASTAL COMBATANTS

PG	LCG(M)	4	1		Indaw	1944		380t, 47.1x6.8x2.1m, 2d, 1000hp, 11.7kts, 39p; 25sides, 51deck, 25turrets, 25CT; 2x1-88/27, 2x1-40/39; type 974 radar
			2		Inlay	1944		
			3		Inma	1944		
			4		Inya	1944		
PB	Fairmile B	5	ML391, 414, 415, 418, 437			1943-1944		86t, 34.8x5.6x1.5m, 2pe, 1200hp, 18kts, 16p; 1x1-47/40, 1x1-40/39, 1x2-20/70; radar
	Singapore ML	2	ML1102, 1103			1939	No picture	60t, 23.3x4.1x1.5m, 2d+1pe, 780hp, 16kts; 1x1-47/40, 1x2-20/70, mechanical minesweeping gear
	HDML	19	ML1205, 1206, 1272, 1286, 1298, 1299, 1304, 1306, 1368, 1374, 1424, 1456, 1462, 1463, 1467, 1477, 1478, 1486, 1488			1943-1945		54t, 22.0x4.8x1.4m, 2d, 260-320hp, 11-11.8kts, 10p; 2x1-20/70, 2dcr; type 291 radar

MINE WARFARE

MSC	MMS1	2	MMS197	1942		295t, 36.4x7.1x2.7m, 1d, 375-500hp, 10-11kts, 20p; 2x1-20/70, mechanical, acoustic, magnetic minesweeping gear
			MMS201	1943		

© Ivan Gogin, 2016

[home](#)

[World navies yesterday](#)

[1950](#)

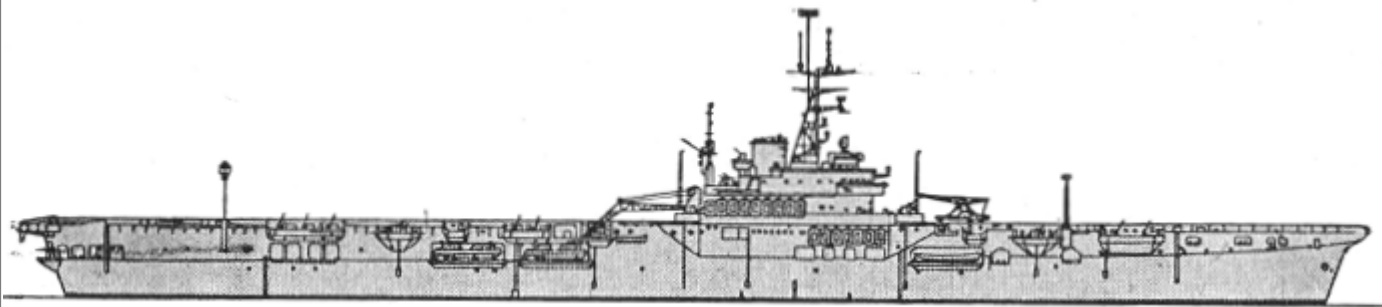

Canada 01 January 1950

AIRCRAFT CARRIERS

CVL	Majestic	1	21	Magnificent	1948		<p>17780t, 211.8x24.4x7.0m, 4b,2gst, 40000hp, 25kts, 1300p; 19x1-40/60, 6x4-40/39, 37aircraft(Seafire, Firefly, Sea Fury fighters); type 79B, 281B radars, type 144 sonar</p>
-----	----------	---	----	-------------	------	--	---

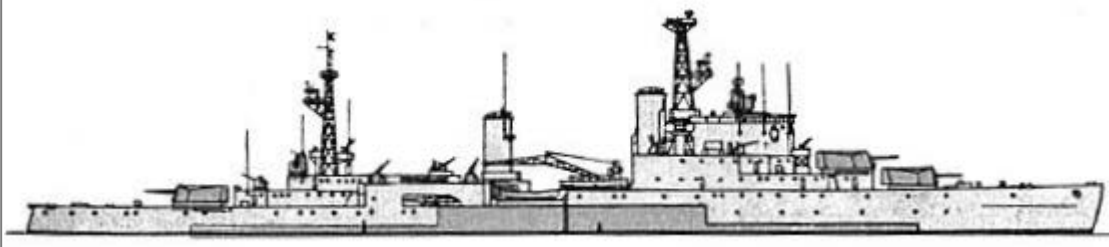
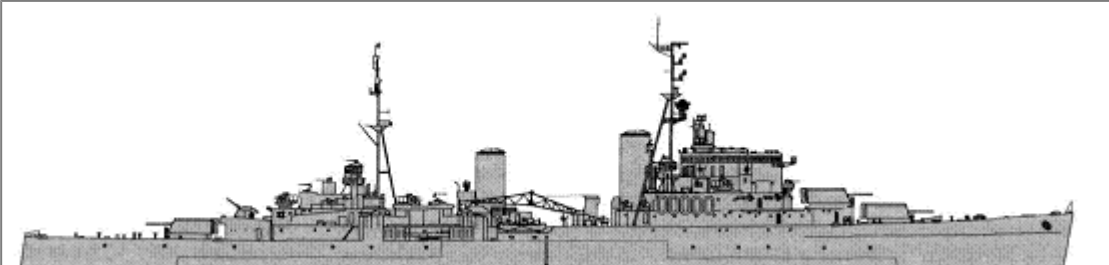
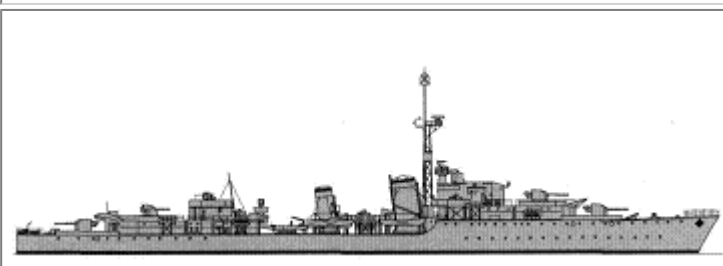
PRINCIPAL SURFACE COMBATANTS

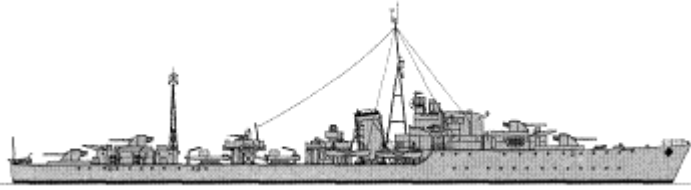
CL	Fiji	1	66	Uganda	1943		<p>11090t, 169.3x18.9x6.3m, 4b,4gst, 72500hp, 31.5kts, 730p; 89belt, 51deck, 51turrets; 3x3-152/50, 4x2-102/45, (5x4+4x1)-40/39, 12x1-20/70, 2x3-533TT; type 274, 277, 281B, 285, 293 radars</p>
	Ontario	1	53	Ontario	1945		<p>11480t, 169.3x19.2x6.5m, 4b,4gst, 72500hp, 31.5kts, 855p; 89belt, 51deck, 51turrets; 3x3-152/50, 5x2-102/45, 4x1-40/60, (4x4+4x1)-40/39, (8x2+6x1)-20/70, 2x3-533TT; type 275, 277, 281B, 283, 284, 285, 293 radars</p>
	Tribal	7	R96	Nootka	1946		<p>2745t, 114.9x11.4x4.2m, 3b,2gst, 44000hp, 36.2kts, 250p; 4x2-102/45, (2x2+2x1)-40/60(96,10), (1x2+2x1)-40/60(all-96,10), 2x2-20/70(96,10,04,79), 1x4-533TT, 1x3-305 Squid ASWRL; type 262, 268, 277, 291, Mk28 radars, type 123A, 127 sonars</p>
R10			Micmac	1945			
G63			Haida	1943			
G24			Huron	1943			
G89			Iroquois	1942			
R04			Cayuga	1947			

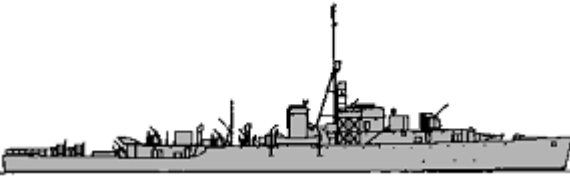
DD	V		R79	Athabaskan	1948		2545t, 110.6x10.9x4.4m, 2b,2gst, 40000hp, 36.7kts, 225p; 4x1-120/45, 1x2-40/60(17), (1x2+2x1)-40/60(64), 4x2-20/70(17), 2x2-20/70(64), 2x4-533TT, 4dct, 2dcr; type 275, 277, 282, 291 radars, type 123A, 127 sonars
			R17	Algonquin	1944		
		2	R64	Sioux	1944		
	Cr		D26	Crescent	1945		
2		D28	Crusader	1945			
FF	early River	6	K321	New Waterford	1944		2180t, 91.8x11.2x3.9m, 2b,2vte, 5500hp, 20kts, 140p; 1x2-102/40, (4x2+2x1)-20/70, 1x24-178 Hedgehog ASWRL, 8dct, 2dcr; type 272, 291 radars, sonars
			K328	Swansea	1943		
			K322	Outremont	1943		
			K320	New Glasgow	1943		
			K325	St. Catherine's	1943		
			K330	Waskesiu	1943		
	later River	18	K661	Antigonish	1944		2180t, 91.8x11.2x3.9m, 2b,2vte, 5500hp, 20kts, 140p; 1x2-102/45, (4x2+2x1)-20/70, 1x24-178 Hedgehog ASWRL, 8dct, 2dcr; type 268, 272, 275, 291 radars, sonars
			K531	Stonetown	1944		
			K407	Beacon Hill	1944		
			K668	La Hullose	1944		
			K676	Penetang	1944		
			K667	Inch Arran	1944		
			K366	Ste. Therese	1944		
			K681	Stetter	1944		
			K670	Fort Erie	1944		
			K683	Sussexvale	1944		
			K685	Buckingham	1944		
			K662	Prestonian	1944		
K663	Cap de la Madeleine	1944					
K318	Jonquiere	1944					
K538	Toronto	1944					
K684	Victoriaville	1944					
K669	Lanark	1944					
K371	Lauzon	1944					
			K101	Nanaimo	1941		
			K110	Shediac	1941		
			K112	Matapedia	1941		
			K113	Arvida	1941		

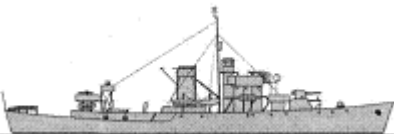
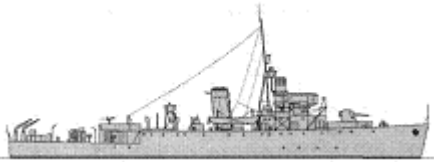
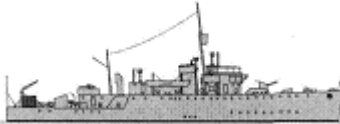
FS	Flower	18	K116	Chambly	1940		<p>1280-1350(238)t, 62.5-63.5(238)x10.1x4.8m, 2b,2vte, 2750hp, 16.5kts, 109p; 1x1-102/45, 4x1-20/70, 4dct, 2dcr; type 286, 290 radars, sonar</p>
			K119	Orilia	1940		
			K121	Rimouski	1941		
			K124	Cobalt	1940		
			K125	Kenogami	1941		
			K139	Moncton	1942		
			K146	Pictou	1941		
			K160	Lethbridge	1941		
			K174	Trail	1941		
			K180	Collingwood	1940		
			K181	Sackville	1941		
			K218	Brantford	1942		
			K228	New Westminster	1942		
K238	Woodstock	1942					
FS	modified Flower	6	K15	Atholl	1943		<p>1370t, 63.5x10.1x4.4m, 2b,2vte, 2750hp, 16.5kts, 109p; 1x1-102/40, (2x2+2x1)-20/70, 1x24-178 Hedgehog ASWRL, 4dct, 2dcr; type 268, 276 radars, sonar</p>
			K341	Parry Sound	1944		
			K345	Smith's Falls	1944		
			K402	Giffard	1943		
			K415	Hawkesbury	1944		
			K485	Mimico	1944		
FS	Algerine VTE engined	8	J326	Kapuskasing	1944		<p>1325t, 68.6x10.8x3.3m, 2b,2vte, 2400hp, 16.5kts, 138p; 1x1-102/45, 4x2-20/70, 4dct, 2dcr</p>
			J330	Oshawa	1944		
			J331	Portage	1943		
			J334	Sault Ste. Marie	1943		
			J336	Wallaceburg	1943		
			J337	Winnipeg	1943		
			J355	Rockcliff	1944		
			J397	New Liskeard	1944		
FS	Bangor diesel-engined (RCMP)	8	J263	Cygnus (RCMP)	1941		<p>690t, 49.4x8.5x2.8m, 2d, 2000hp, 16.5kts, 60p; 1x1-102/40(263), 1x1-76/40(all-263), 3x1-20/70, 4dct, 2dcr; radar, sonar</p>
			J264	Colonel White (RCMP)	1942		
			J265	Irvine (RCMP)	1942		
			J267	Perry (RCMP)	1942		
			J268	Herchmer (RCMP)	1942		
				MacBrien			

			J269	(RCMP)	1942	
			J270	MacLeod (RCMP)	1942	
			J271	French (RCMP)	1942	

PATROL AND COASTAL COMBATANTS

PC	Givenchy	2	1	Arras	1918	No picture	440t, 39.6ppx7.1x4.1m, 1vte, 10.5kts; 1x1-76/40
			2	Givenchy	1917		
PB	Fairmile B	8	PTC704	Cougar	1943		86t, 34.8x5.6x1.5m, 2pe, 1200hp, 18kts, 16p; (1x2+4x1)-20/70, 2dct, 2dcr; type 970 radar, sonar
			PTC706	Beaver	1943		
			PTC711	Moose	1943		
			PTC716	Reindeer	1944		
			PTC721		1944		
			PTC724	Elk	1944		
			PTC762	Wolf	1942		
			PTC779	Racoon	1942		

MINE WARFARE SHIPS

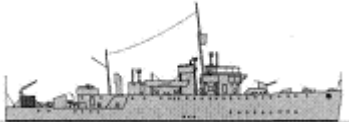
ML	Isles	2	1	Stonechat	1944		770t, 50.0x8.4x3.4m, 1b,1vte, 850hp, 12.2kts, 40p; 1x1-76/40, 3x1-20/70, mines
			2	Whitethroat	1944		
MSO	Bangor VTE-engined	20	J144	Georgian	1941		875t, 54.9x8.7x3.1m, 2b,2vte, 2400hp, 16.5kts, 87p; 1x1-102/40 or 1x1-76/45 or 1x1-76/40, 3x1-20/70, 4dct, 2dcr, sweeps; radar, sonar
			J160	Chignecto	1941		
			J181	Drummondville	1941		
			J182	Kentville	1942		
			J183	Port Hope	1942		
			J184	Gananoque	1941		
			J185	Swift Current	1941		
			J186	Malpeque	1941		
			J187	Westmount	1942		
			J188	Nipigon	1941		
			J189	Minas	1941		
			J190	Sarnia	1942		
			J191	Kenora	1942		
			J192	Mahone	1941		
			J193	Blairmore	1942		
J194	Milltown	1942					
J196	Red Deer	1941					

			J197	Medicine Hat	1941		
			J260	Goderich	1941		
			J311	Fort William	1942		
MSC	105ft Admiralty	3	J278	Llewellyn	1942		295t, 36.4x7.1x2.7m, 1d, 375-500hp, 10-11kts, 20p; 2x1-20/70, sweeps
			J279	Lloyd George	1942		
			J373	Revelstoke	1944		

© Ivan Gogin, 2015

[home](#)

[World navies yesterday](#)

[1950](#)

Ceylon 01 January 1950

MINE WARFARE

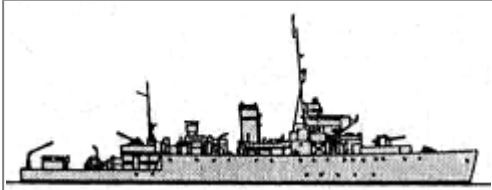
MSO	Algerine VTE	1	M370	Vijaya	1944		1325t, 68.6x10.8x3.3m, 2b,2vte, 2400hp, 16.5kts, 138p; 1x1-102/45, 4x1-40/60, 2dct, 2dcr, mechanical minesweeping gear; radar, sonar
-----	-----------------	---	------	--------	------	--	--

© Ivan Gogin, 2016

[home](#)[World navies yesterday](#)[1950](#)

Chile 01 January 1950

SUBMARINES

SS	H1	2	4	Guale	1916		364/434t, 45.8x4.7x3.8m, 2d/em, 480/620hp, 13/11kts, 22p, 30m; 4-450TT
			6	Fresia	1916		
SS	O'Brien	3	O	Capitán O'Brien	1929		1540/2020t, 79.3x8.5x4.2m, 2d/em, 2750/1300hp, 15/9kts, 54p, 95m; 1x1-120/45, 8-533TT
			S	Almirante Simpson	1929		
			T	Capitán Thomson	1929		

PRINCIPAL SURFACE COMBATANTS

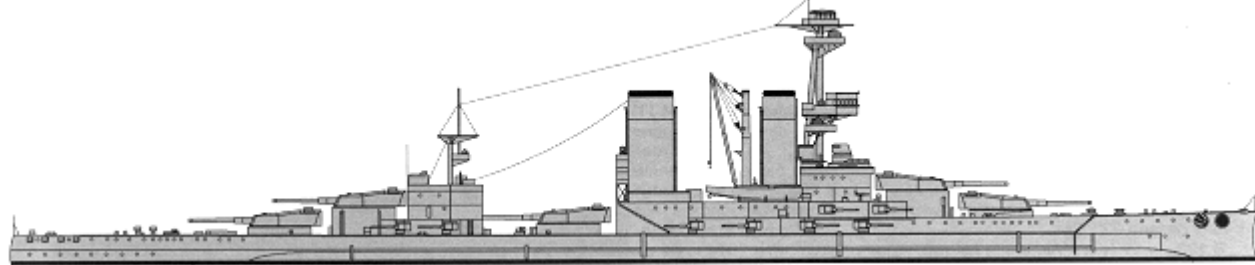
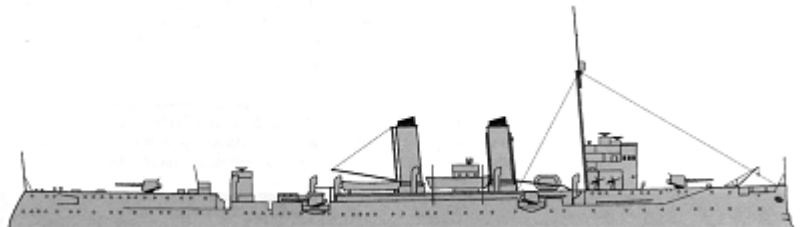
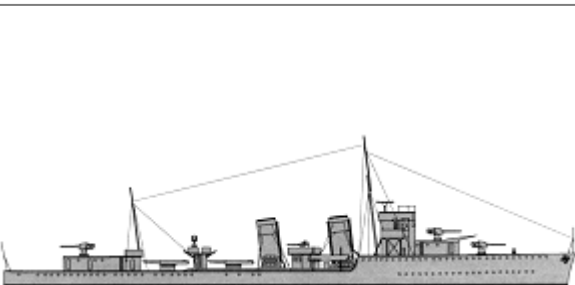

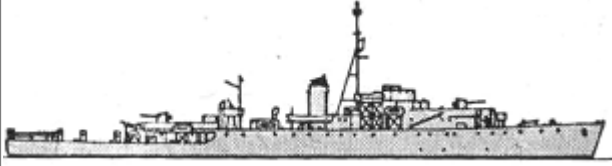
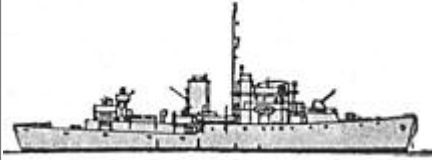
BB	Almirante Latorre	1	1	Almirante Latorre	1915		32800t, 201.5x31.4x8.7m, 21b,4st, 55000hp, 22.4kts, 1167p; 229belt, 63deck, 254turrets, 279CT; 5x2-356/45, 14x1-152/50, 4x1-102/45, 2x1-40/39, 6x1-13.2, 4-533TT
CL	Chacabuco	1	1	Chacabuco	1902		4877t, 127.5x14.2x5.2m, 8b,2vte, 15700hp, 23kts, 400p; Harvey- 114slopes, 44deck, 114shields, 76CT; 6x1-152/50, 10x1-20/70
DD	Serrano	6	A	Sargento Aldea	1929		1430t, 91.4x8.8x3.9m, 3b,2gst, 28000hp, 35kts, 130p; 3x1-120/45, 1x1-76/40, 3x1-20/70, 2x3-533TT, 2dct; mines(S,O,H), sweeps(A,R,V)
			H	Ingeniero Hyatt	1929		
			O	Capitán Orella	1928		
			R	Guardiamarina Riquelme	1929		
			S	Teniente Serrano	1928		
			V	Cirujano	1929		

				Videla			
FF	River	3	E	Esmeralda	1944		2180t, 91.8x11.2x3.9m, 2b,2vte, 5500hp, 20kts, 140p; 1x2-102/45, 1x1-76/40, (4x2+2x1)-20/70, 1x24-178 Hedgehog ASWRL, 8dct, 2dcr; type 268, 272, 275, 291 radars, sonars
			I	Iquique	1944		
			C	Covadonga	1944		
FS	Flower mod	3	C	Casma	1944		1370t, 63.5x10.1x4.4m, 2b,1vte, 2750hp, 16.5kts, 109p; 1x1-102/40, (2x2+2x1)-20/70, 1x24-178 Hedgehog ASWRL, 4dct, 2dcr; type 268, 276 radars, sonar
			C2	Chipana	1944		
			P	Papudo	1944		

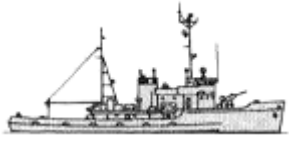
PATROL AND COASTAL COMBATANTS

PS	Sotoyomo	3	1	Lautaro	1943		835t, 43.6x10.3x4.0m, 2dg,2em, 1500hp, 13kts, 49p; 1x1-40/60, 2x1-20/70; Decca 1226 radar
			2	Lientur	1944		
			3	Leucotón	1944		

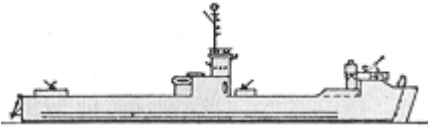
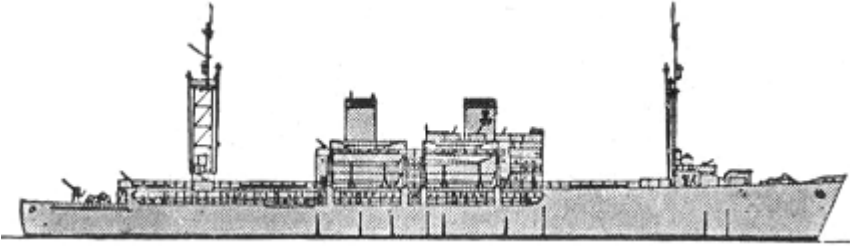
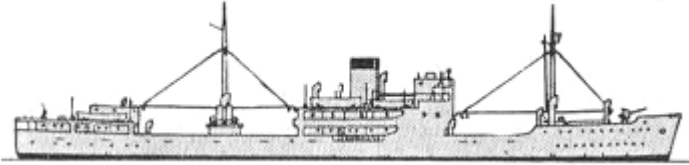
AMPHIBIOUS

LSM	LSM1	4	1	Aspirante Isaza	1944		1095t, 62.0x10.5x2.1m, 8d(2), 2800hp, 13.2kts, 60p; 1x2-40/60, 4x1-20/70; 5tanks, 54troops; radar
			2	Aspirante Goycolea	1945		
			3	Aspirante Morel	1944		
			4	Guardiamarina Contreras	1944		
LKA	Artemis	2	1	Presidente Errázuriz	1945		6740t, 129.9x17.7x4.7m, 2b,2tg,2em; 6000hp, 18kts, 303p; 1x1-127/38, 4x2-40/60, 10x1-20/70; 13 LCVP, 2 LCM(3), 1 LCPL, 2900t cargo, 252troops; radar
			2	Presidente Pinto	1945		
	Angamos	1	1	Angamos	1946		3800t, 104.0xxm, 12kts; 1x1-102/50, 2x1-20/70; cargo, troops
LCU	LCI(L)	6	1	Grumete Tellez	1944		385t, 48.9x7.2x1.6m, 8d(2)), 2320hp, 15.5kts, 29p; 5x1-20/70; 209troops; SCR-517A radar
			2	Soldado Canave	1944		
			3	Grumete Bolados	1944		
			4	Grumete Díaz	1944		
			5	Cabo Bustos	1944		
			6	Eduardo Llanos	1944		

MINE WARFARE





ML	Filin	3	1	Elicura	1920		545t, 52.6x7.5x3.4m, 3b,2vte, 1400hp, 14.5kts, 42p; 2x1-76/40, 50mines
			2	Leucotón	1920		
			3	Oropello	1920		

© Ivan Gogin, 2015

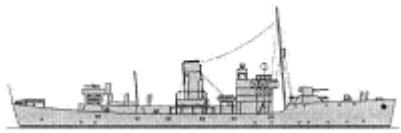
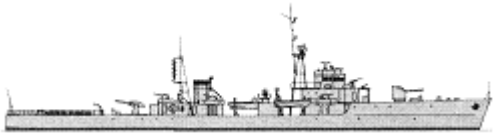

[home](#)[World navies yesterday](#)[1950](#)

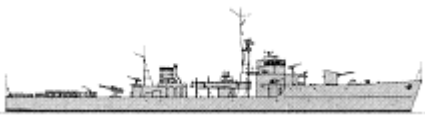





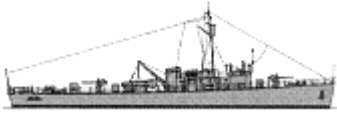

China 01 January 1950

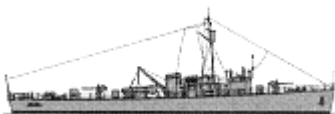
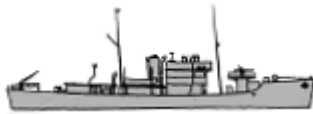

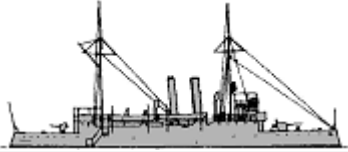
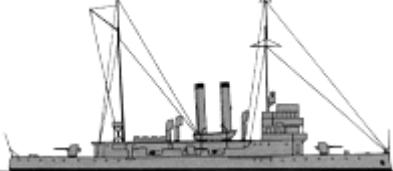

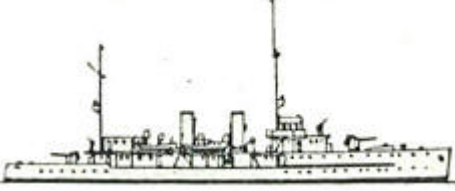

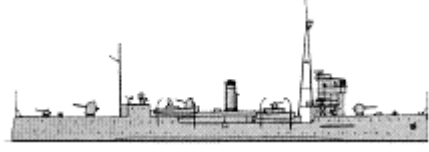

PRINCIPAL SURFACE COMBATANTS

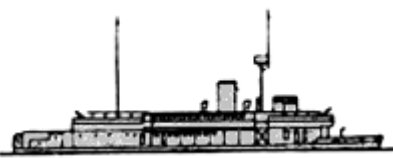
FF	Flower	3	1	Kaifeng	1941		1170t, 62.5x10.1x4.1m, 2b,1vte, 2750hp, 16.5kts, 109p; 2x1-100/56, 1x1-45/68(1), 4x1-37/73(1), 2x1-37/73(2,3)
			2	ex-Mawhwa	1940		
			3	Linyi	1940		
FF	Ukuru	1	1	Huian	1944		1020t, 78.8x9.1x3.1m, 2d, 4200hp, 19.5kts, 150p; (1x2+1x1)-120/45, (5x3+5x1)-25/60, 1x1-81/12 ASWM, 12dct; 22-go, 13-go radars, sonar
			1	Kuangchou	1944		
FF	Castle	2	2	ex-Shihlin	1944		1630t, 76.8x11.2x4.2m, 2b,1vte, 2750hp, 16.5kts, 120p; 2x1-130/51, 1x1-45/69, 5x1-37/73; type 276, 291 radars, sonar
			1	Wuchang	1944		
FS	D	4	2	Changsha	1944		940t, 69.5x8.6x3.1m, 2b,1gst, 2500hp, 17.5kts, 160p; 2x1-120/45, (2x3+2x2+4x1)-25/60, 1x1-81/12 ASWM, 12dct; 22-go, 13-go radars
			3	Weihai	1945		
			4	Xian	1945		
			1	Shengyang	1945		
FS	C	1	1	Shengyang	1945		810t, 67.5x8.4x2.9m, 2d, 1900hp, 16.5kts, 136p; 2x1-120/45, (2x3+2x2+4x1)-25/60, 1x1-81/12 ASWM, 12dct; 22-go, 13-go radars
			1	Loyang	1941		
FS	Bathurst	1	1	Loyang	1941		790t, 56.7x9.5x3.0m, 2b,2vte, 2000hp, 16kts, 90p; 2x1-130/51, 2x1-37/73, radar
			1	Shengyang	1945		

PATROL AND COASTAL COMBATANTS

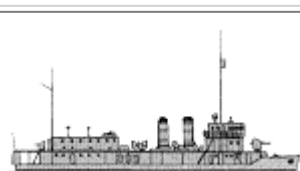

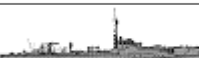
PC	2	1	ex-PC593	1943		463t, 52.9x7.1x3.3m, 2d, 2880hp, 19kts, 65p; 1x1-76/50, 1x1-40/60, 4x1-20/70, 2x4-178 Mousetrap ASWRL, 2dct, 2dcr; SU radar, sonar
		2	ex-PC595	1943		
PC	1	1	Tungping	1945		463t, 52.9x7.1x3.3m, 2d, 2880hp, 19kts, 65p; 1x1-76/50, 1x2-40/60, 6x1-20/70, 1x2-60/12 ASWM, 2x1-12.7; SU radar,
		1	Tungping	1945		

PC	PGM	3	2	ex-PGM14	1945		sonar	
		3		Kantang	1945			
	Isles	2	1		ex-Chunghai	1941		770t, 50.0x8.4x3.4m, 1b,1vte, 850hp, 12.2kts, 40p; 1x1-76/40, 3x1-20/70, 4dct, 2dcr, sweeps
			2		ex-Sunghwei	1941		
	Basset	1	1	Sungming	1938		775t, 50.0x8.4x3.4m, 1b,1vte, 950hp, 13kts, 33p; 1x1-102/40, 3x1-20/70, 2dct, 2dcr, sweeps	
	Kiangyuan	1	1	Kiangyuan	1905		565t, 54.1x8.5x2.1m, 2b,2vte, 950hp, 13kts, 85p; 1x1-120/40, 1x1-76/40, 4x1-47/40	
	Chuyu	1	1	Chutung	1906		752t, 61.0x9.0x2.4m, 2b,2vte, 1350hp, 13kts, 117p; 2x1-120/40, 2x1-76/40	
	Yungchien	2	1		Yungchien	1915		1039t, 65.7x9.0x3.5m, 2b,2vte, 1350hp, 13kts, 105p; 25deck; 1x1-102/50(2), 2x1-76/40(1), 1x1-76/40(2), 4x1-47/40(2), 2x1-37/27(2)
			2		Haihsing	1916		
	Yungsui	1	1	Yungsui	1929		800t, 70.0x9.1x1.8m, 2b,2vte, 4000hp, 18.5kts, 100p; 1x1-152/50, 1x1-120/45, 3x1-76/40, 4x1-57/40, 1x1-40/39	
Mingchuen	1	1	Hsiening	1930		500t, 61.8x7.9x1.8m, 2b,2vte, 2400hp, 16.6kts, 146p; 1x1-120/45, 1x1-102/45, 1x1-76/40, 2x1-57/40, 1x1-47/40		
Ataka	1	1	Antung	1923		1094t, 71.7x9.8x2.3m, 2b,2vte, 1700hp, 16kts, 118p; 1x1-120/45, 2x1-76/40, 4x2-13.2, 1dct		
Uji	1	1	Changchi	1941		1110t, 80.5x9.7x2.5m, 2b,2gst, 4600hp, 19.5kts, 170p; (1x2+1x1)-120/45, 2x2-25/60		
Wenhsing	1	1	Wenhsing	1934	No picture	340t, 43.5x7.0x2.0m, 2d, 1400hp, 15kts; 2x1-47/40		

PCR	Gannet	1	1	Yingshan	1928		400t, 56.4x8.8x1.3m, 2b,2gst, 2250hp, 16kts, 55p; 2x1-76/45
	Falcon	1	1	Yingteh	1931		470t, 45.7x8.8x1.8m, 2b,2gst, 2250hp, 15kts, 55p; 1x1-87/13, 2x1-57/40
	Sandpiper	1	1	Yinghao	1933		215t, 51.0x9.4x0.6m, 1b,2vte, 600hp, 11.2kts, 35p; 1x1-87/13, 1x1-57/40
	Wake	2	1	Meiyuan	1928		395t, 48.6x8.3x1.6m, 2b,2vte, 1950hp, 14.5kts, 70p; 2x1-76/50
			2	Taiyuan	1927		
	Toba	1	1	Hohseuh	1911		291t, 55.9x8.2x0.8m, 2b,3vte, 1400hp, 15kts, 59p; 2x1-76/40, 3x1-25/60
	Seta	1	1	Changteh	1923		400t, 56.1x8.2x1.0m, 2b,2vte, 2100hp, 16kts, 62p; 2x1-76/40, 5x1-13.2
	Atami	2	1	Yungping	1929		249t, 46.3x6.3x0.9m, 2b,2vte, 1300hp, 16.7kts, 77p; 3x1-76/40, 3x1-25/60, 3x1-13.2
			2	Yungan	1930		
	Fushimi	2	1	Chiangfeng	1939		368t, 50.3x9.8x1.3m, 2b,2gst, 2200hp, 17kts, 64p; 1x1-76/40, 1x1-25/60
2			Nanchang	1940			
Ermanno Carlotto	1	1	Kiangkun	1921		218t, 48.8x7.5x0.9m, 2b,2vte, 14kts, 44p; 2x1-76/40	
Macau	1	1	Wufeng	1909		133t, 36.5x6.0x0.7m, 1b,2vte, 250hp, 11.8kts, 24p; 2x1-57/40	
PB	Yue 22	1	1	Haixin	1937		60t, 28.0x4.3x1.5m, 3pe, 3300hp, 33kts, 12p; 1x1-20/65
	Kaoming	2	1	Kaoming	1944		135t, 29.2x5.7x2.0m, 1d, 400hp, 11kts, 32p; 1x1-25/60, 1dct
			2	Kuangkuo	1944		
SC	1	1	Chuchien	1942		136t, 33.8x5.5x2.0m, 2d, 1000hp, 16kts, 27p; 1x1-40/60, 3x1-20/70, 2x4-178 Mousetrap ASWRL, 2dct, 2dcr; SW-1C	



			101		radar, QC sonar
--	--	--	-----	--	-----------------

AMPHIBIOUS

LST	LST(2)	14	1	Chanbaishan	1942		4080t, 100.0x15.2x4.3m, 2d, 1800hp, 12.1kts, 125p; (2x2+4x1)-40/60, 12x1-20/70; 4 LCVP, 20tanks, 163troops; radar
			2	Takushan	1943		
			3	Wugongshan	1944		
			4	Taihashan	1944		
			5	Dabieshan	1944		
			6	ex-Chung 107	1944		
			7	Luliangshan	1945		
			8	Tiangmushan	1944		
			9	Yimengshan	1944		
			10	Soraishan	1944		
			11	Dahushan	1944		
			12	Simingshan	1944		
			13	Jinggangshan	1944		
			14	ex-Chungye	1944		
LSM	LSM	14	1	Yongming	1944		1095t, 62.0x10.5x2.1m, 2d, 2800hp, 13kts, 60p; 1x2-40/60, 4x1-20/70; 5tanks, 54troops; radar
			2	Meijian	1944		
			3	Meile	1945		
			4	Meicheng	1945		
			5	Meiping	1945		
			6	Meiwei	1945		
			7	Meihan	1945		
			8	Meigong	1945		
			9		1944		
			10		1944		
			11		1944		
			12		1944		
			13		1944		
			14		1944		
LCT(6)		10	1		1943		320t, 36.3x10.0x1.2m, 3d, 675hp, 8kts, 13p; 2x1-20/70; 4tanks
			2		1944		
			3		1944		
			4		1944		
			5		1944		
			6		1944		
			7		1944		

LCU	LCI(L) 14	8		1944		385t, 48.9x7.2x1.6m, 2d, 2320hp, 15.5kts, 29p; 5x1-20/70; 209troops; radar
		9		1944		
		10		1944		
		1		1943		
		2		1943		
		3		1943		
		4		1943		
		5		1943		
		6		1943		
		7		1943		
		8		1943		
		9		1944		
		10		1944		
		11		1944		
12		1944				
13		1944				
14		1944				

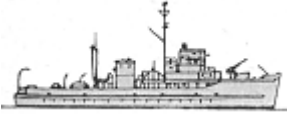
MINE WARFARE

ML	Tunghsi	2	1	Tunghsi	1949	No picture	500t, 52.0x9.7x3.3m, 2vte, 2000hp, 13kts; 1x1-76/50, 4x1-47/40, mines
			2	Tungteh	1949		
MSC	YMS	5	1	ex-BYMS2017	1942		320t, 41.5x7.5x2.4m, 2d, 800hp, 14kts, 60p; 1x1-76/50, 2x1-20/70, 2dct, 2dcr, sweeps; radar
			2	ex-YMS339	1943		
			3	ex-YMS346	1943		
			4	ex-YMS367	1943		
			5	ex-YMS393	1943		
MSI	Wa1	2	1	ex-No4	1942		222t, 33.0x5.9x2.3m, 1d, 300hp, 9.5kts, 43p; 1x1-76/23, 4x1-25/60, sweeps, 1dcr
			2	ex-No14	1943		

© Ivan Gogin, 2015

[home](#)[World navies yesterday](#)[1950](#)

Colombia 01 January 1950

PRINCIPAL SURFACE COMBATANTS

DD	Lima	2	D01	Antioquia	1934		1563t, 98.5x9.4x2.7m, 3b,2gst, 33000hp, 36kts, 147p; 4x1-120/50, 3x1-40/39, 2x1-20/70, 2x4-533TT, 20mines, 2dct
			D02	Caldas	1934		
FF	Tacoma	1	FG11	Almirante Padilla	1944		2238t, 92.6x11.4x3.9m, 3b,2vte, 5500hp, 20kts, 190p; 3x1-76/50, 2x2-40/60, 9x1-20/70, 1x24-178 Hedgehog ASWRL, 8dct, 2dcr; SA, SF, Mk26 radars, sonar

PATROL AND COASTAL COMBATANTS

PC	Carabobo	3	1	Carabobo	1925	No picture	120t, 33.0x6.0x2.5m, 1b,1vte, 300hp, 13kts, 37p; 1x1-75/35, 1x1-20/70
			2	Junin	1925		
			3	Pichincha	1925		
APC	-	1	1	Mariscal Sucre	1909		125t; 2x1-76/40
PR	Cartagena	3	CF31	Barranquilla	1931		142t, 41.8x7.2x0.8m, 2sd, 600hp, 15.5kts, 39p; 1x1-76/40, 1x1-20/70
			CF32	Santa Marta	1931		
			CF33	Cartagena	1931		
APR	-	3	1	Presidente Mosquera	1912		230t; 1x1-76/40
			2	Demetrio Salamanca			120t
			3	Fernández Madrid			150t

COAST GUARD

PB	Capitán R. D. Binney	1	GC101	Capitán R. D. Binney	1947	No picture	23t, 20.4x3.3x1.1m, 2d, 115hp, 13kts
----	----------------------	---	-------	----------------------	------	------------	--------------------------------------

© Ivan Gogin, 2016



[home](#)[World navies yesterday](#)[1950](#)

Cuba 01 January 1950

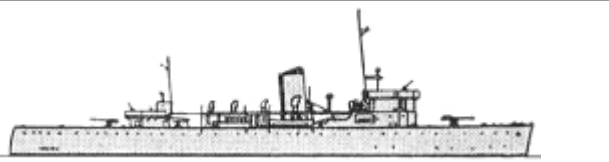
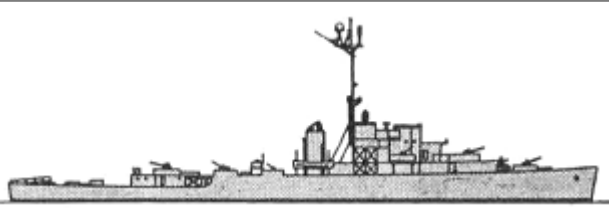
PRINCIPAL SURFACE COMBATANTS

FF	Patria	1	1	Patria	1911		1200t, 61.0x11.0x4.0m, 2b,2vte, 4000hp, 16kts, 115p; 3x1-76/50, 4x1-57/40, 4x1-47/40; radar
	Cuba	1	1	Cuba	1911		2055t, 79.2x11.9x4.3m, 2b,2vte, 6000hp, 18kts, 145p; 2x1-102/50, 2x1-76/50, 2x1-76/23, 6x1-57/40, 2dct; radar
	Tacoma	3		F301 José Martí F302 Antonio Maceo F303 Máximo Gómez	1944 1945 1944		2238t, 92.6x11.4x3.9m, 3b,2vte, 5500hp, 20kts, 190p; 3x1-76/50, 2x2-40/60, 9x1-20/70, 1x24-178 Hedgehog ASWRL, 8dct, 2dcr; SA, Mk26 radars, sonar

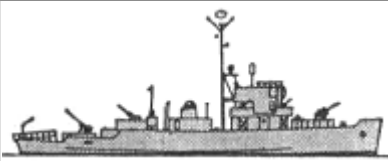
PATROL AND COASTAL COMBATANTS

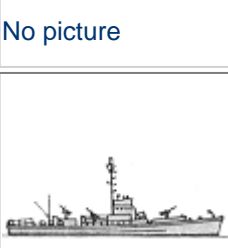
PSO	PCE	2	PCE301	Caribe	1943		903t, 56.2x10.1x2.9m, 2d, 2000hp, 15.1kts, 96p; 1x1-76/50, 3x2-40/60, 4x1-20/70, 1x24-178 Hedgehog ASWRL, 4dct, 2dcr; SO radar, sonar
			PCE302	Siboney	1944		
PB	SC1	4	CS1-4	-	1918		85t, 33.5x4.5x1.7m, 3pe, 660hp, 18kts, 27p; 1x1-76/23, 1dct
	USCG 83ft	12	GC11-14, 21-24, 31-34	-	1942-1943		45t, 25.3x4.9x1.4m, 2pe, 1200hp, 20.5kts, 10p; 1x1-20/70, 2x4-178 Mousetrap ASWRL, 4dcr; radar, sonar
	Leoncio Prado	1	GC101	Leoncio Prado	1946	No picture	80t, 33.5x4.4x2.0m, 2d, 1000hp, 15.9kts; 1x1-20/70, 2dcr; radar
	SC110	5	GC104	Oriente	1943		136t, 33.8x5.5x2.0m, 2d, 1000hp, 16kts, 27p; 1x1-40/60, 3x1-20/70, 2x4-178 Mousetrap ASWRL, 2dct, 2dcr; radar, QC sonar
			GC105	Camaguey	1943		
GC106			Las Villas	1943			
GC107			Habana	1943			

			GC108	Pinar del Río	1943		
Matanzas	1	1		Matanzas	1912	No picture	80t, 30.5x5.5x1.3m, 1b,1vte, 200hp, 12kts, 20p; 1x1-37/40
Capitán Fernández Quevedo	1		GC102	Donativo	1932	No picture	130t, 30.8x5.5x2.1m, 2d, 300hp, 12kts, 21p; 2x1-37/40

© Ivan Gogin, 2016

[home](#)[World navies yesterday](#)[1950](#)

Czechoslovakia 01 January 1950

PATROL AND COASTAL COMBATANTS

PR	DČ-1	1	DČ-1	1949		30t, 20.1x4.2x0.9m, 2pe, 1000hp, 16kts, 12p; 12deck, 80turret, 12CT; 1x1-75/48, 1x4-20/65
	No1	2	No1, 2	1948	No picture	10t, 15.9x3.0x0.9m, 2d, 360hp, 16.7kts, 9p; 1x1-20/65, 1x1-12.7

© Ivan Gogin, 2016



[home](#)[World navies yesterday](#)[1950](#)

Denmark 01 January 1950

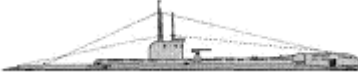
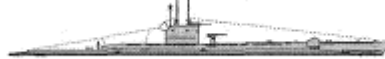
SUBMARINES

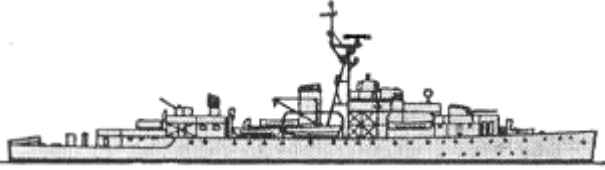

SS	Havmanden	4	H1	Havmanden	1938		335/407t, 47.5x4.7x2.8m, 2d/2em, 1200/450hp, 15.3/7.2kts, 25p; 1x1-40/60, 5-450TT
			H2	Havfruen	1939		
			H3	Havkalen	1939		
			H4	Havhesten	1942		
U	1	U1	U1	1942		646/732t, 60.0x4.9x4.7m, 2dg,2em, 615/825hp, 11.2/10kts, 33p, 60m; 1x1-76/45, 4-533TT; type 291W radar, sonars	
U long hull	2	U2	U2	1944		662/740t, 62.3x4.9x4.7m, 2dg,2em, 615/825hp, 11.2/10kts, 33p, 90m; 1x1-76/45, 2x1-20/70, 4-533TT; type 267QW radar, sonar	
		U3	U3	1944			

PRINCIPAL SURFACE COMBATANTS

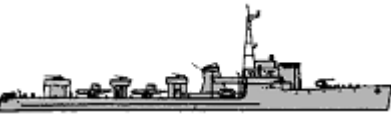

FF	River	2	F1	Holger Danske	1944		2180t, 91.8x11.2x3.9m, 2b,2vte, 5500hp, 20kts, 140p; 2x1-127/38, 1x1-40/60, (2x2+4x1)-20/70, 2x1-450TT, 1x24-178 Hedgehog ASWRL, 4dct, 2dcr; type 271, 291 radars, sonars
			F2	Niels Ebbesen	1944		
FS	Flower	1	1	Thetis	1940		1170t, 62.5x10.1x4.1m, 2b,1vte, 2750hp, 16.5kts, 109p; 1x1-75/55, 2x1-57/40, 2x1-20/70, 1x24-178 Hedgehog ASWRL, 4dct, 2dcr; type 286, 290 radars, sonar
	Huitfeldt	2	T1	Huitfeldt	1947		901t, 86.5x8.5x3.3m, 2b,2gst, 24000hp, 35kts, 108p; 2x1-105/45, 2x1-40/60, 6x1-20/60, 2x3-450TT, 2dct, 60mines; radar, sonar
			T2	Willemoes	1947		



PATROL AND COASTAL COMBATANTS

PCT	Bille	5	T11	Bille	1948		400t, 63.9x6.4x2.3m, 2b,2gst, 6900hp, 29kts, 65p; 3x1-37/83, 2x1-20/70, 2x3-450TT, 2dct, 2dcr, 40mines; radar, sonar
			T12	Buhl	1949		
			T14	Holm	1949		
			T15	Krabbe	1948		

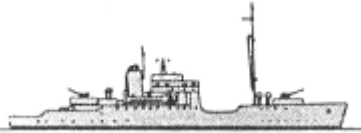
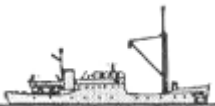
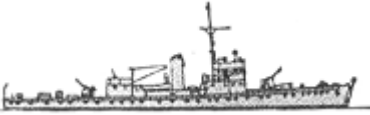
			T16	Krieger	1948		
PT	S300	2	T51	T51	1946		124t, 34.9x5.3x1.7m, 3d, 9000hp, 443.6kts, 45p; (2x2+2x1)-20/65, 2-533TT, 2dcr, 6mines
			T57	T57	1945		
	S38	3	T52	T52	1941		115t, 34.9x5.3x1.7m, 3d, 6000(52)-7500(54,56)hp, 39(52)-41(54,56)kts, 45p; (2x2+1x1)-20/65, 2-533TT, 2dcr, 6mines
			T54	T54	1943		
			T56	T56	1943		
	S139	3	T53	T53	1944		122t, 34.9x5.3x1.7m, 3d, 7500hp, 41kts, 31p; (2x2+1x1)-20/65, 2-533TT, 2dcr, 6mines
			T55	T55	1944		
			T59	T59	1944		

MINE WARFARE

ML	Lindormen	1	M1	Lindormen	1940		645t, 53.5x8.8x2.4m, 2b,2vte, 1200hp, 66p; 2x1-75/55, 3x1-20/60, 138mines
	Lougen	2	MF3	Lougen	1941		350t, 34.2x6.6x2.2m, 2d, 350hp, 11kts, 32p; 2x1-20/60, 18mines
MF4			Laaland	1941			
MSC	Søløven	4	M1	Søløven	1939		304t, 53.6x6.4x2.0m, 1b, 1gst, 2200hp, 19.5kts, 48p; 2x1-75/40, 2x1-20/65, 30mines, minesweeping gear
			M4	Søridderen	1942		
			M5	Søhesten	1942		
			M6	Søhunden	1942		
	MMS1001	3	ME1038		1943		430t, 42.7x8.5x3.2m, 1d, 500hp, 10kts, 21p; 2x1-20/70, mechanical, magnetic, acoustic minesweeping gear
ME1042		1943					
ME1044		1944					
MSI	R151	13	MR152		1940		126t, 35.4x5.6x1.5m, 2d, 1800hp, 23.5kts, 31p; 1x1-37/83, (2x2+1x1)-20/65, 2dcr, 10mines, minesweeping gear
			MR154		1940		
			MR155		1940		
			MR156		1940		
			MR157		1940		
			MR167		1941		
			MR168		1941		
			MR170		1941		
			MR173		1941		
			MR174		1941		
			MR175		1941		
			MR176		1941		
			MR214		1943		
	R218	4	MR229		1944		148t, 39.4x5.7x1.6m, 2d, 2500hp, 21kts, 40p; 1x1-37/83, 3x2-20/65, 12mines, minesweeping gear, 2dcr
MR230				1944			

							
				1944			
				1944			
MSB	MS1	9	MS1		1941		74t, 24.4x4.6x1.5m, 1d, 250hp, 11kts, 11p; 1x1-20/70, minesweeping gear
			MS2		1941		
			MS3		1941		
			MS5		1941		
			MS6		1941		
			MS7		1941		
			MS8		1941		
			MS9		1941		
			MS10		1941		
			MSK1	3	MSK1		
	MSK2				1945		
	MSK3				1945		
	MSK4	3	MSK4		1945	No picture	72t, 21.0x5.2x2.7m, 1d, 120hp, 10kts; 1x1-20/60, minesweeping gear
			MSK5		1945		
			MSK6		1945		
	ML1	3	ML1		1946	No picture	21t, 15.2x4.2x1.3m, 1d; minesweeping gear
			ML2		1946		
			ML3		1947		

FISHERY PROTECTION

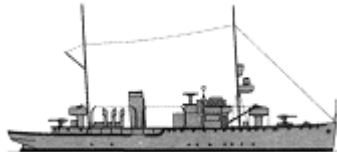
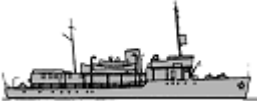



PS	Hejmdal	1	1	Hejmdal	1935		825t, 53.3x9.2x3.6m, 2b,1vte, 800hp, 12.5kts, 49p; 2x1-75/55, 2x2-20/60
	ARS	1	1	Vitus Bering	1943	No picture	1615t, 55.9x11.3x4.3m, 4dg,1em, 1200hp, 12kts, 65p; 1x1-75/55, 2x1-20/70
PC	Freja	1	1	Freja	1939		342t, 40.9x7.7x2.2m, 1b,1vte, 255hp, 10.5kts, 40p; 2x1-20/60
PB	Maagen	1	1	Maagen	1932	No picture	110t, 21.8x5.4x2.9m, 1d, 120hp, 8kts, 11p; 1x1-37/20
	Ternen	1	1	Ternen	1937	No picture	82t, 20.9x5.1x3.0m, 1d, 110hp, 8kts, 11p; 1x1-37/20

© Ivan Gogin, 2016

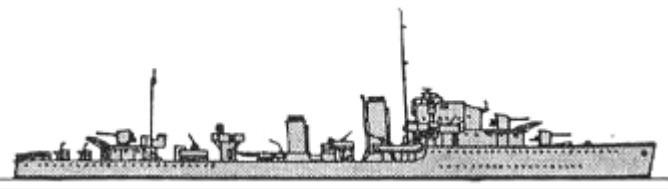

[home](#)[World navies yesterday](#)[1950](#)

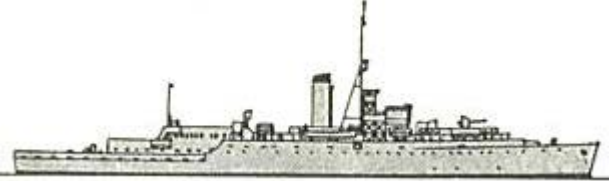
Dominican Republic 01 January 1950

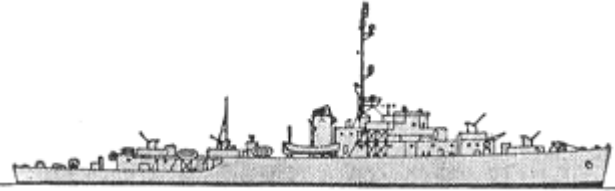
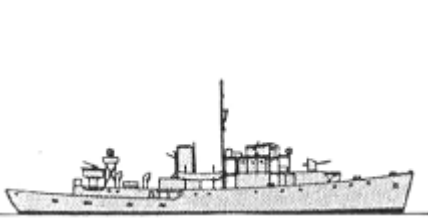

PRINCIPAL SURFACE COMBATANTS

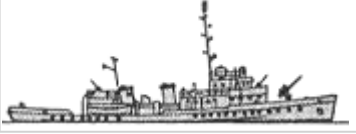
DD	H	1	D101	Trujillo	1936		2095t, 98.5x10.1x4.1m, 3b,2gst, 34000hp, 36kts, 145p; 3x1-120/45, (2x2+2x1)-20/70, 1x4-533TT, 4dct, 1dcr, minesweeping gear; radars, type 124 sonar
	F	1	D102	Generalissimo	1935		2095t, 100.3x10.1x4.0m, 3b,2gst, 36000hp, 36kts, 145p; 4x1-120/45, (2x2+2x1)-20/70, 4dct, 1dcr, minesweeping gear; radars, type 121 sonar
FF	River	1	F101	Presidente Trujillo	1944		2125t, 91.8x11.2x3.9m, 2b,2vte, 5500hp, 20kts, 195p; 1x1-102/41, 2x1-47/40, 1x1-40/60, 4x1-20/70; radar
	Ashville	1	F102	Juan Pablo Duarte	1942		2150t, 91.9x11.1x4.0m, 2b,2vte, 5500hp, 20kts, 190p; 3x1-76/50, 2x2-40/60, 4x1-20/70, 1x24-178 Hedgehog ASWRL, 8dct, 2dcr; SA, SF, Mk26 radars, sonar
	Tacoma	2	F103	Presidente Troncoso	1944		2238t, 92.6x11.4x3.9m, 3b,2vte, 5500hp, 20kts, 190p; 3x1-76/50, 2x2-40/60, 6x1-20/70, 2x2-12.7; SA, SF, Mk26 radars
			F104	Presidente Peynado	1944		
FS	mod. Flower	5	C101	Cristobal Colón	1944		1350t, 63.5x10.1x4.4m, 2b,1vte, 2750hp, 16.5kts, 109p; 1x1-102/40, 1x1-40/60, 2x1-20/70, 1x24-178 Hedgehog ASWRL, 4dct, 2dcr; type 268, 276 radars, sonar
			C102	Juan Alejandro Acosta	1943		
			C103	Juan Bautista Cambiaso	1944		
			C104	Gerardo Jansen	1944		
			C105	Juan Bautista Maggiolo	1943		

PATROL AND COASTAL COMBATANTS

PC	PC173	3	P101	27 de Febrero	1943		463t, 52.9x7.1x3.3m, 2d, 2880(101,102)-1800(103)hp, 19(101,102)-17(103)kts, 65p; 1x1-76/50, 1x1-40/60, 1x1-20/70; SO radar
			P102	Capitán Wenceslao Arvelo	1943		
			P103	Cibas	1942		
	Argo	3	P104	Restauración	1933		370t, 50.3x7.2x2.3m, 2d, 1340hp, 16kts, 50p; 1x1-76/50, 1x1-40/60, 1x1-20/70; radar
			P105	Independencia	1932		
			P106	Rafael Atoa	1931		
PB	GC75ft	6	GC1, 3-7		1924-1926	No picture	37t, 22.9x4.2x1.2m, 1pe, 400hp, 13.5kts, 12p; 2x1-20/70, 2dcr
			GC2		1918	No picture	18t, 13.7x3.4x1.1m, 2pe, 200hp, 9.5kts
			GC8		1941	No picture	28t, 19.0x3.7x1.2m, 1pe, 200hp, 10kts, 10p
	GC9	3	GC9	Luperón	1943	No picture	45t, 25.3x4.9x1.4m, 2pe, 1200hp, 20.5kts, 14p; 2x1-20/70, 2dcr
			GC10	22 de Julio	1943		
			GC11	16 de Agosto	1943		
	AVR	3	LR101		1945	No picture	100t, 31.9x5.9x1.7m, 2pe, 1000hp, 17kts, 20p; 2x1-20/70
			LR102		1945		
			LR103		1945		
	SC110	2	GC101	Sanchez	1943		136t, 33.8x5.5x2.0m, 2d, 1000hp, 16kts, 27p; 1x1-40/60, 3x1-20/70, 2x4-178 Mousetrap ASWRL, 2dct, 2dcr; SO radar, QC sonar
GC102			Mella	1943			

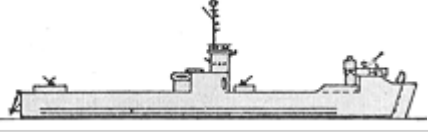
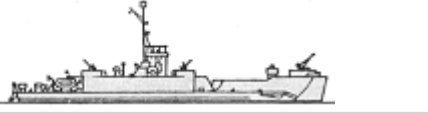
AMPHIBIOUS

LSM	LSM1	1	BA103	San Rafael	1944		1095t, 62.0x10.5x2.1m, 2d, 2800hp, 13.2kts, 60p; 1x2-40/60, 4x1-20/70; 5tanks, 54troops; radar
LCU	LCI(L)1	2	BDI101	Beller	1942		387t, 48.5x7.2x1.5m, 8d(2), 2320hp, 15.5kts, 24p; 4x1-20/70; SO radar; 180troops
			BDI102	Palo Incaldo	1943		
	LCT(5)	1	LA2	Samaná	1943		286t, 34.8x10.0x1.3m, 3d, 675hp, 8kts, 11p; 1x1-12.7; 4tanks
	LCT(6)	2	LA3	17 de Julio	1944		320t, 36.3x10.0x1.2m, 3d, 675hp, 8kts, 13p; 1x1-12.7; 4tanks
LA4			María Josefina	1944			

© Ivan Gogin, 2016

[home](#)[World navies yesterday](#)[1950](#)

Ecuador 01 January 1950

PRINCIPAL SURFACE COMBATANTS

FF	Tacoma	1	E01	Guayas	1944	A detailed line drawing of the USS Tacoma (FF-1071), a Fletcher-class destroyer, shown from a starboard profile view. The ship features a complex superstructure with multiple masts, radar masts, and gun mounts.	2238t, 92.6x11.4x3.9m, 3b,2vte, 5500hp, 20kts, 190p; 3x1-76/50, 2x1-40/60, 4x1-20/70, 6dct, 2dcr; SA, SF, Mk26 radars, sonar
----	--------	---	-----	--------	------	--	--

PATROL AND COASTAL COMBATANTS

APS	-	4	1	Abdón Calderón	1884		300t; 4x1-76/40
			2	Manabí	1922		590t; 2x1-76/50
			3	Esmeraldas	1922	A line drawing of the Esmeraldas, a small coastal patrol vessel, shown from a starboard profile view. It has a simple hull and a small superstructure.	565t; 1x1-76/50
			4	Presidente Alfaro	1917	A line drawing of the Presidente Alfaro, a larger coastal patrol vessel, shown from a starboard profile view. It features two masts and a more complex superstructure than the Esmeraldas.	869t; 2x1-76/50
PC	APc	1	1	El Oro	1943	A line drawing of the El Oro, a small patrol boat, shown from a starboard profile view. It has a very simple hull and a small cabin.	234t, 31.4x6.5x2.8m, 1d, 400hp, 10kts, 25p; 4x1-20/70; 66troops

© Ivan Gogin, 2016

[home](#)[World navies yesterday](#)[1950](#)

Egypt 01 January 1950

PRINCIPAL SURFACE COMBATANTS

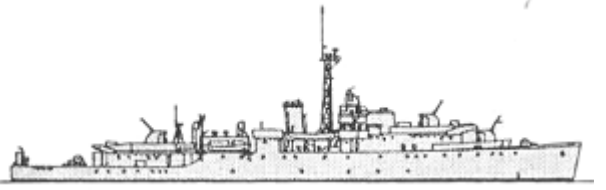
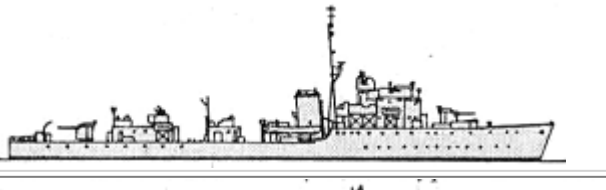
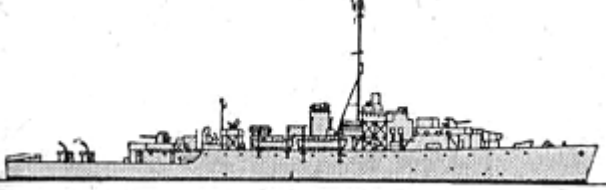
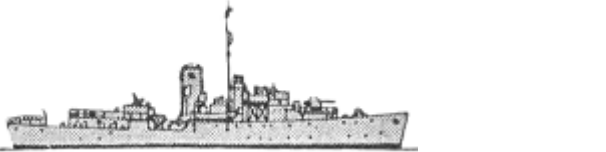
FF	mod. Black Swan	1	42	El Malek Farouq	1943		1950t, 91.3x11.7x3.4m, 2b,2gst, 4300hp, 19.7kts, 192p; 3x2-102/45, 2x2-40/60, (2x2+2x1)-20/70, 8dct, 2dcr; type 272, 285, 291 radars, type 147, 177 sonars
	Hunt batch 1	1	1	Mohammed Ali	1940		1450t, 85.3x8.8x3.8m, 2b,2gst, 19000hp, 28kts, 147p; 2x2-102/45, (1x4+1x1)-40/39, 2x1-20/70, 2dct, 1dcr; type 285 radar, type 123A, 177 sonars
	River	1	43	Rashid	1942		2180t, 91.8x11.2x3.9m, 2b,2vte, 5500hp, 20kts, 140p; 2x1-102/40, 6x1-40/60, 1x24-178 Hedgehog ASWRL, 8dct, 2dcr; type 277, 291 radars, sonars
	Flower	1	1	As Sudan	1940		1170t, 62.5x10.1x4.1m, 2b,1vte, 2750hp, 16.5kts, 109p; 1x1-102/45, 1x1-40/39, 2x1-20/70, 2dct, 2dcr; type 286, 290 radars, sonar

PATROL AND COASTAL COMBATANTS

PB	Darfeel	2	1	Darfeel	1925	No picture	20t, 17.1xxm, 330hp, 17kts; 1x1-37/30
			2	Noor El Bahr	1925		
	Qamar	1	1	Qamar	1930s	No picture	23t, 21.6xxm, 11kts
	El Hoot	1	1	El Hoot	1930s	No picture	24t, 14.0xxm, 7kts
	Al Sarea	1	1	Al Sarea	1936	No picture	20t, 16.8x3.5x1.0m, 2pe, 900hp, 35kts, 9p; 1x1-37/30
	Raqib	1	1	Raqib	1938	No picture	20.1xxm, 2d, 540hp, 15kts; 1x1-37/30
	Fairmile B	3	1	Hamza	1943		86t, 34.8x5.6x1.5m, 2pe, 1200hp, 18kts, 16p; 1x1-47/40, (1x2+1x1)-20/70, 2dcr; type 286 radar, sonar
2			Sab El Bahr	1943			
3			Saker Al Bahar	1943			

PR	El Zafir	2	1	El Zafir	1896	No picture	128t, sw; 1x1-76/40
			2	El Fateh	1897		

AMPHIBIOUS

LC	LCM(3)	20	1-20	-	1942-1945		52t, 15.3x4.3x1.4m, 2d, 330hp, 8kts, 4p; 2x1-12.7; 1tank or 60troops
----	--------	----	------	---	-----------	---	--

MINE WARFARE





MSO	Bangor	3	1	Matrouh	1941		875t, 54.9x8.7x3.1m, 2b,2vte, 2400hp, 16.5kts, 87p; 1x1-102/45, 1x1-76/45, 2x1-40/60, 2x1-20/70, 2dct; radar, sonar
			2	Nasr	1941		
			3	Sollum	1942		
MSC	YMS	2	1	Gaza	1942		250t, 41.5x7.5x2.4m, 2d, 800hp, 15kts, 60p; 1x1-76/50, 2x1-20/70, mechanical, acoustic, magnetic minesweeping gear; radar
			2	Arish	1942		

© Ivan Gogin, 2016

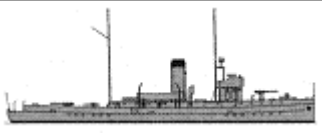

[home](#)[World navies yesterday](#)[1950](#)

Finland 01 January 1950

PATROL AND COASTAL COMBATANTS

PC	Filin	1	Karjala	1918		342t, 50.1x6.8x2.3m, 2b,2vte, 1150hp, 15kts, 48p; 2x1-75/50, 3x1-20/60, 30mines
		2	Turunmaa	1918		
	Golub'	1	Hämeenmaa	1918		530t, 52.0x7.5x3.4m, 3b,2vte, 1400hp, 15kts, 55p; 2x1-105/45, 2x1-40/60, 1x1-20/60
		2	Uusimaa	1918		
PG	Baglietto 500	4	J1-4 Jylhä, Jyry, Jyske, Jymy	1939		25t, 18.7x4.6x1.5m, 2pe/2pe(2), 2300/100hp, 42kts, 10p; 1x1-20/65, 1x1-13.2
	H	5	H1-5 Hyöky, Hirmu, Hurja, Hyrsky, Häijy	1943		22t, 16.5x4.3x1.5m, 2pe/2pe(2), 1600/100hp, 36kts, 11p; 2x1-20/65, 2x1-13.2
	T	8	T1-8 Taisto 1-8	1943-1946		22t, 17.8x4.6x1.5m, 2pe, 2300hp, 48kts; 1x1-40/60, 2x1-13.2

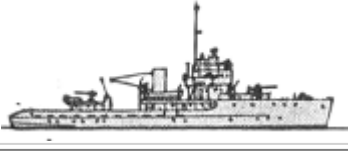
MINE WARFARE SHIPS

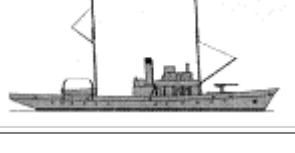
ML	Ruotsinsalmi	1	1	Ruotsinsalmi	1941		370t, 50.0x7.9x1.5m, 2d, 1120hp, 15kts, 60p; 1x1-75/50, 1x1-40/60, 2x1-20/60, 100mines, sweeps
MSC	YMS	4	1	Katanpää	1943		250t, 41.5x7.5x2.4m, 2d, 800hp, 15kts, 60p; 1x1-76/50, 2x1-20/70, sweeps; SO radar
			2	Purunpää	1943		
			3	Vahterpää	1942		
			4	Tammenpää	1943		
MSI	Udarnik	1	1	Rautu	1918		220t, 43.6x6.1x1.7m, 2b,2vte, 400hp, 11kts, 35p; 1x1-75/50, 1x1-47/40, sweeps
	Pukkio	3	1	Pukkio	1940	No picture	162t, 27.0x6.7x2.5m, 1d, 300hp, 10kts; 1x1-40/60, 1x1-20/70, 20mines
			2	Porkkala	1940		
			3	Pansio	1947		
			1		DR1	1943	

	ST	8	2	DR2	1943	No picture	150t, 21.0x6.2x2.6m, 1d, 400hp, 10kts; sweeps
			4	DR4	1943		
			5	DR5	1943		
			7	DR7	1943		
			10	DR10	1943		
			13	DR13	1943		
			18	DR18	1944		
MSB	Ahven	6	1-6	Ahven 1-6	1936-1937	No picture	17t, 17.2x3.8x1.3m, 1d, 65hp, 10kts, 8p; 1x1-20/60, sweeps
	SM	3	1, 2, 4	SM1, 2, 4	1939-1940	No picture	20t, 18.0x3.8x1.7m, 1pe, 80hp, 9kts; 1x1-20/60, sweeps
	Kuha	15	2, 3, 5, 7-18	Kuha 2, 3, 5, 7-18	1941-1946		17t, 17.2x3.8x1.6m, 1d, 70hp, 9kts; 1x1-20/60, sweeps
	Ajonpää	2	1, 2	Ajonpää, Kallanpää	1941-1942	No picture	52t, 20.0x5.3x1.7m, 1d, 200hp, 10kts; 1x1-20/60, sweeps

COAST GUARD



PS	-	1	1	Tursas	1933	No picture	400t, 40.0x7.2x4.3m, 1d, 620hp, 12kts; 1x1-76/50, 1x1-40/60, 2x1-20/70
PB	VMV1	2	VMV1, 2	-	1930	No picture	30t, 23.5x4.2x1.0m, 2pe/1pe(2), 1120/100hp, 25kts, 8p; 1x1-20/60
	VMV5	2	VMV5, 6	-	1931	No picture	30t, 24.6x4.4x1.1m, 2pe/1pe(2), 900/140hp, 24.6kts, 8p; 1x1-20/60
	VMV8	5	VMV9, 11, 13, 15, 16	-	1935		31t, 25.6x4.4x1.0m, 2sd/1sd(2), 1120/180hp, 23.8kts, 8p; 1x1-20/65
	SP1	1	VMV18	-	1935	No picture	21t, 21.9xxm, 11kts
	SP41	2	VMV19, 20	-	1943	No picture	22t, 21.9xxm, 10kts

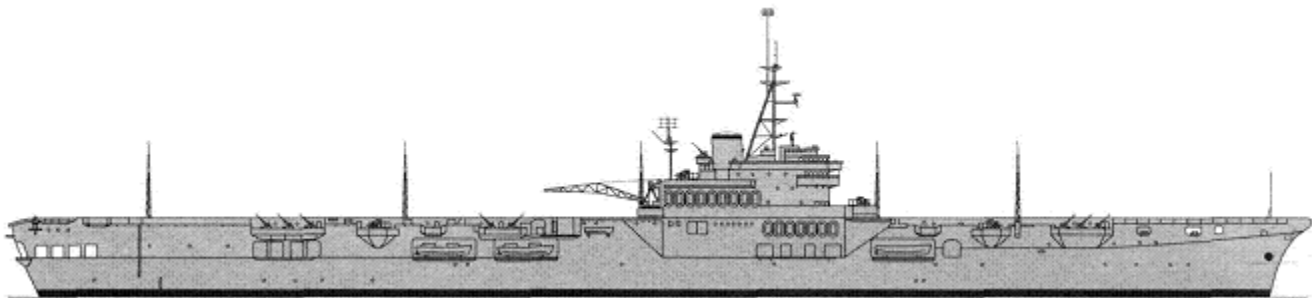

© Ivan Gogin, 2016

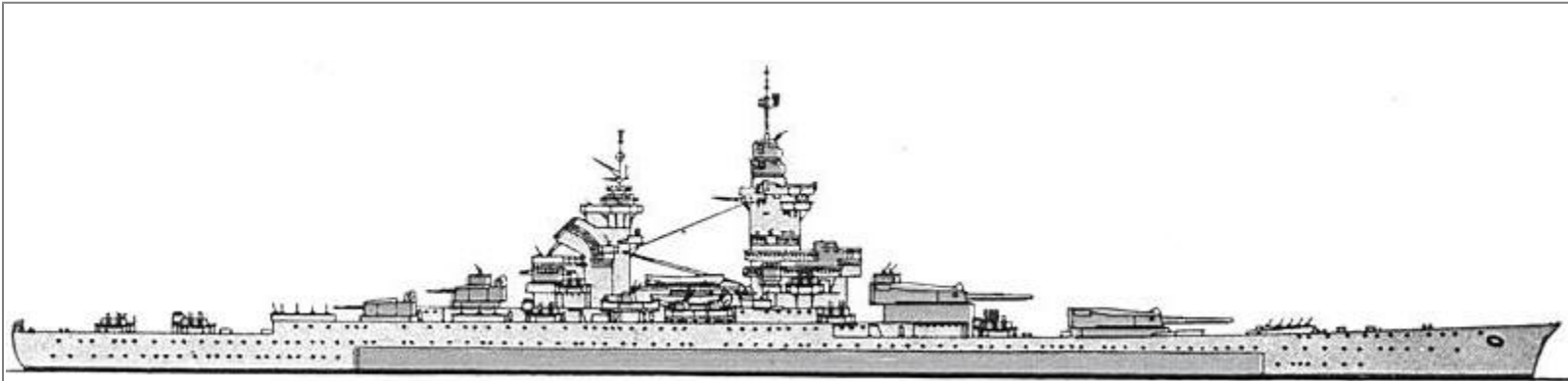
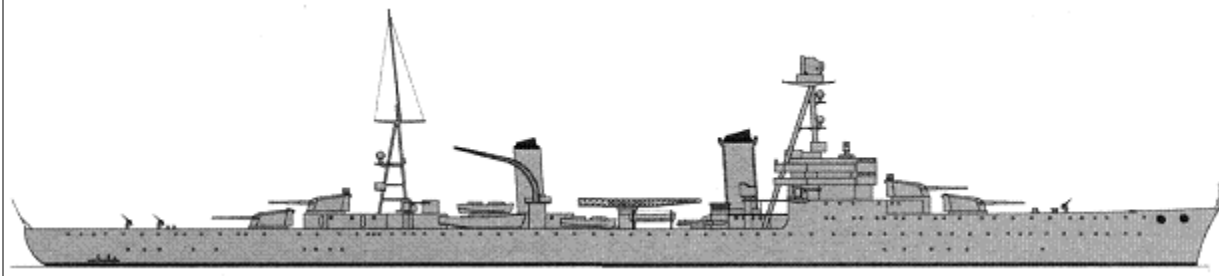
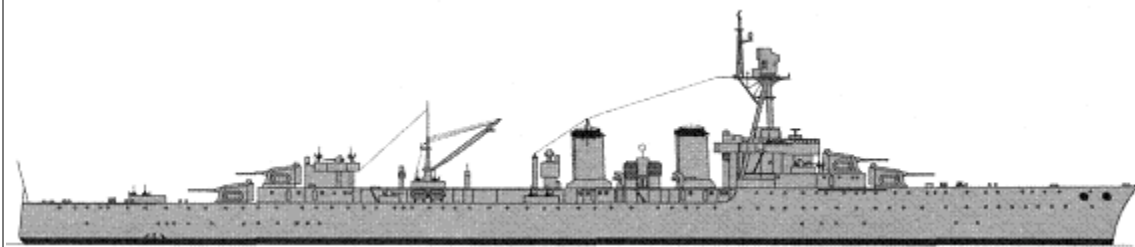
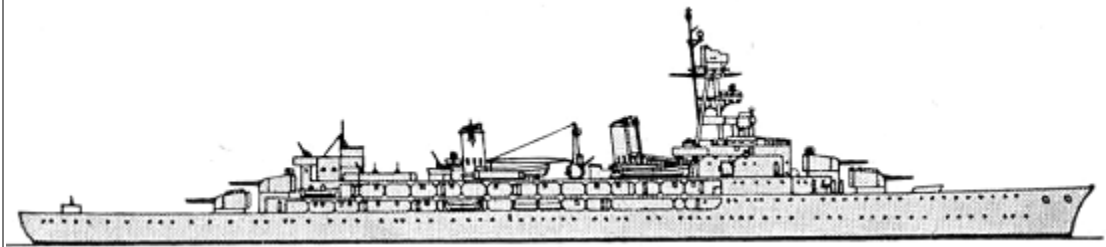
CVL	Colossus	1	1	Arromanches	1944		17900t, 211.3x34.2x7.1m, 4b,2gst, 40000hp, 25kts, 1400p; 19x1-40/60, 6x4-40/39, 37aircraft(Seafire); type 79B, 281B radars, type 144 sonar
-----	----------	---	---	-------------	------	---	--

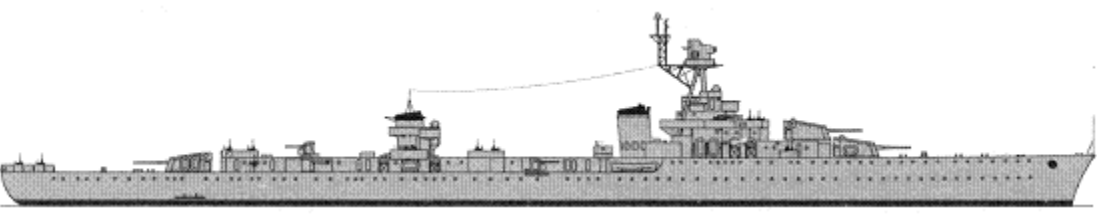
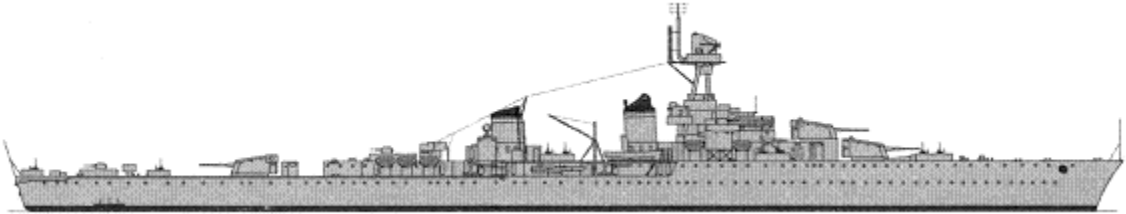
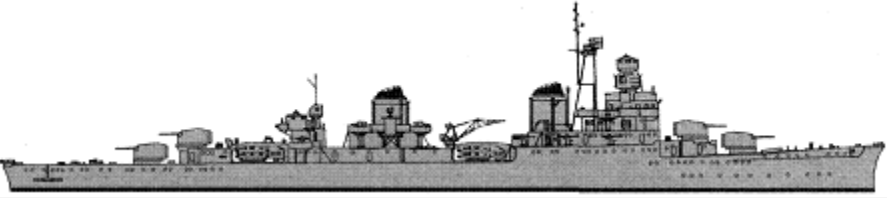
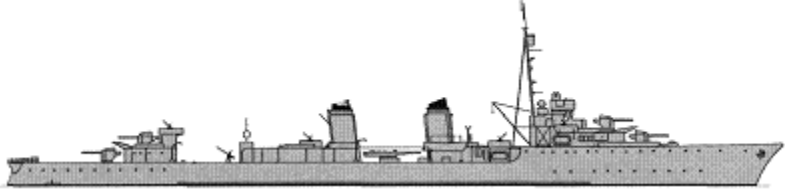
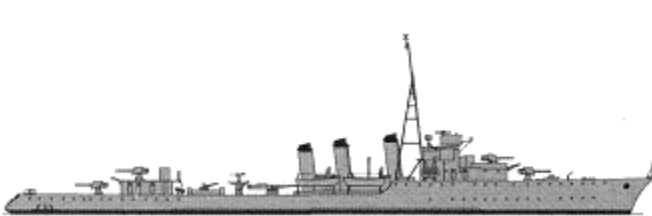
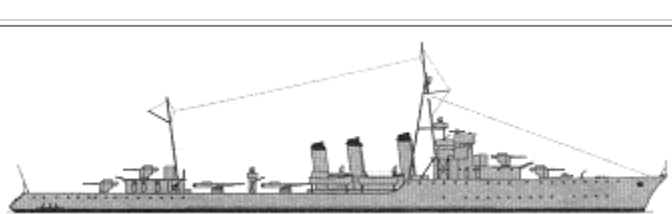

PRINCIPAL SURFACE COMBATANTS

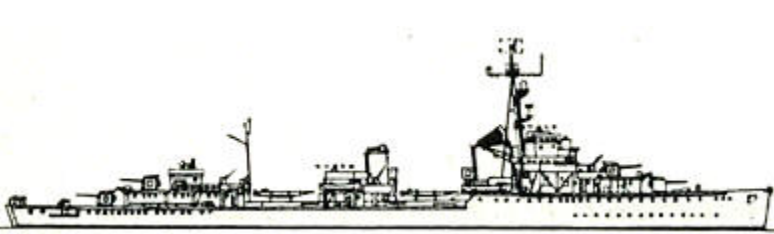
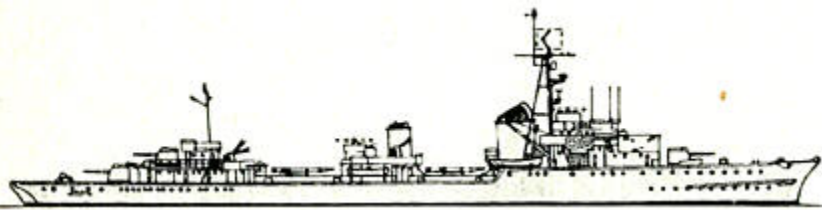
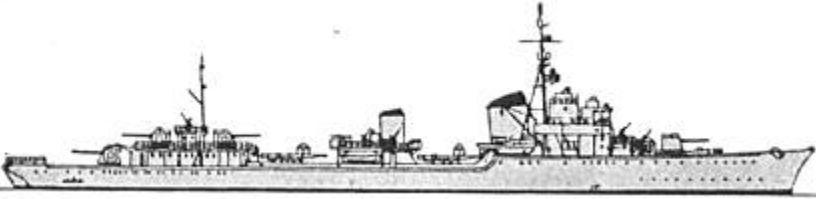
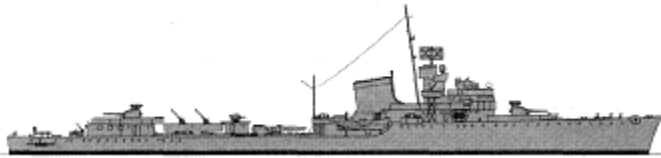
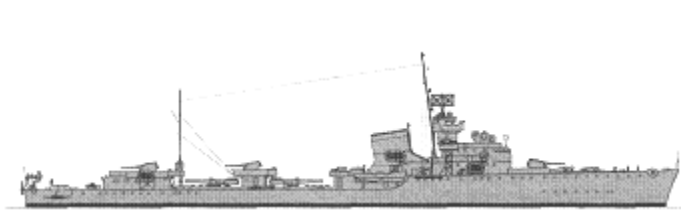
BB	Richelieu	2	2	Richelieu	1940		48500(1)-49850(2)t, 247.9x33.0(1)-35.4(2)x9.9(1)-9.2(2)m, 6b,4gst, 150000(1)-162000(2)hp, 30(1)-32(2)kts, 1550(1)-2134(2)p; 330belt, 210decks, 430turrets, 340CT; 2x4-381/45, 3x3-152/55, 12x2-100/55(2), 6x2-100/45(1), 4x1-90/50(1), 14x2-57/60(2), (14x4+11x1)-40/60(1), 41x1-20/70(1), 20x1-20/70(2); Sadir ME.140/126(1), SA-2(1), SF(1), type 284(1), 281B(1), 285(1), SG-1(1), ABM(2), DRBV-10(2), DRBV-20(2), DRBV-30(2) radars
CA	Suffren	1	1	Suffren	1930		12928t, 196.0x20.0x7.3m, 8b,3gst, 90000hp, 32kts, 602p; 50belt, 43decks, 30turrets, 30CT; 4x2-203/50, 8x1-75/50, 8x1-40/60, 20x1-20/70, 3x4-13.2
	Duguay Trouin	1	1	Duguay Trouin	1926		9350t, 181.6x17.2x5.2m, 8b,4gst, 100000hp, 33kts, 578p; 20deck, 25turrets, 25CT; 4x2-155/50, 4x1-75/50, 6x1-40/60, 18x1-20/70, 2x1-13.2; SF-1, SA radars
	Jeanne d'Arc	1	1	Jeanne d'Arc	1931		8950t, 170.0x17.7x6.4m, 4b,2gst, 32500hp, 25kts, 506+176p; 20magazines, 25turrets, 25CT; 4x2-155/50, 4x1-75/50, 10x1-40/60, 18x1-20/70; SF radar
							8480t, 177.0x16.0x6.6m, 6b,4gst, 102000hp, 34kts, 567p;

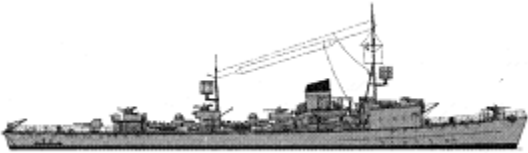
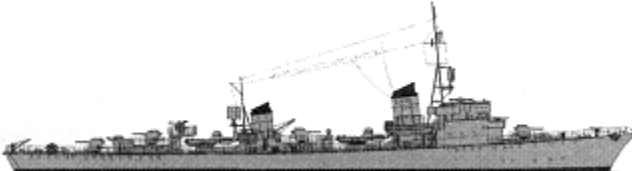
CL	Émile Bertin	1	1	Émile Bertin	1935		30magazines, 20deck, 25CT; 3x3-152/55, (3x2+2x1)-90/50, 4x4-40/60, 20x1-20/70, 200mines; SA, SF, type 284, 285 radars
	La Galissonnière	1		Gloire	1937		10850t, 179.5x17.5x5.4m, 4b,2gst, 84000hp, 31kts, 540p; 105belt, 38deck, 100turrets, 95CT; 3x3-152/55, 4x2-90/50, 6x4-40/60, 16x1-20/70, 2x2-550TT; SF, type 281, 284, 285, 293 radars
		2		Montcalm	1937		
3		3	Georges Leygues	1937			
Capitani Romani	1		Châteaurenault	1942		5334t, 142.9x14.4x4.9m, 4b,2gst, 110000hp, 40kts, 418p; 20turrets, 15CT; 4x2-135/45, 8x1-37/54, 4x2-20/65, 2x4-533TT, 2dct, 2dcr, 136mines; EC.3 radar	
	2	2	Guichen	1943			
Chacal	1	T05	Tigre	1925		3050t, 126.8x11.3x4.1m, 4b,2gst, 40000hp, 28.5kts, 195p; 4x1-130/40, 2x1-40/60, 10x1-20/70, 1x3-550TT, 8dct, 2dcr; radars	
Bourrasque	1		Simoun	1926		1900t, 105.8x9.6x4.3m, 3b,2gst, 33000hp, 33kts, 142p; 3x1-130/40(1,2), 4x1-130/40(4), 4x1-120/45(3), 1x1-76/40(3), 1x1-40/60(1,2), 2x1-37/50(4), 6x1-20/70(1), 8x1-20/70(2), 3x1-20/70(3), 2x2-13.2(4), 1x3-550TT(2,3), 2x3-550TT(4), 2dct, 2dcr; radar, sonar	
	2		Tempête	1926			
	3		Mistral	1927			
	4	4	Trombe	1927			
L'Adroit	1		L'Alcyon	1929		2000t, 107.2x9.8x4.3m, 3b,2gst, 34000hp, 33kts, 142p; 3x1-130/40, 1x1-40/60, 2x1-37/50, 6x1-20/70, 2x2-13.2, 1x3-550TT, 2dct, 2dcr; radar, sonar	
	2		Le Fortune	1928			
	3		Forbin	1930			
	4		Basque	1931			
Aigle	1	T06	Albatros	1932		3410t, 128.5x11.8x5.0m, 4b,2gst, 64000hp, 36kts, 230p; 5x1-139/40, (1x2+4x1)-37/50, (2x2+2x1)-13.2, 2x3-550TT, 4dct, 2dcr; radar, sonar	
Le Fantasque	X01		Le Terrible	1935		3380t, 132.4x12.5x5.0m, 4b,2gst, 74000hp, 37kts, 210p; 5x1-139/50, (1x4+2x1)-40/60(01-03), 3x2-40/60(04), 8x1-20/70(01,03), 10x1-20/70(02,04), 7x1-20/70(04), 2x3-550TT, 2dcr, 50mines; radar, sonar	
	X02		Le Malin	1936			
	X03		Le Fantasque	1936			
	X04		Le Triomphant	1936			

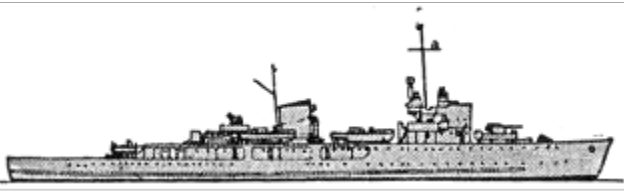
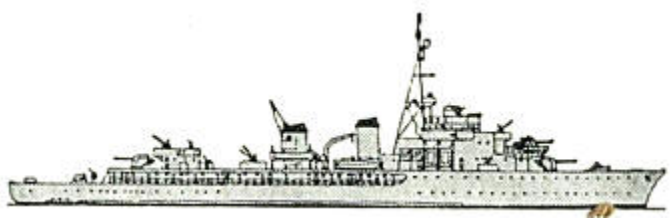
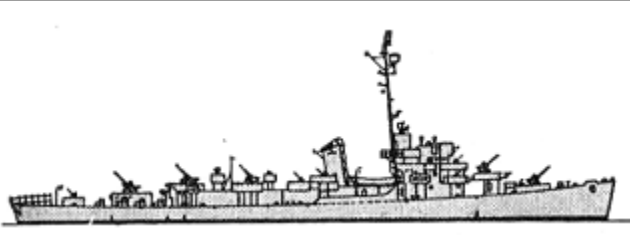
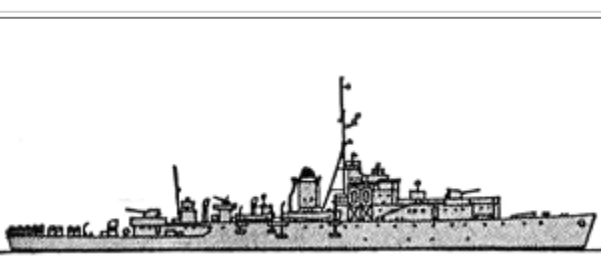
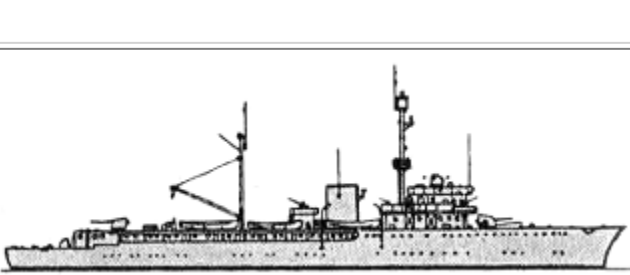
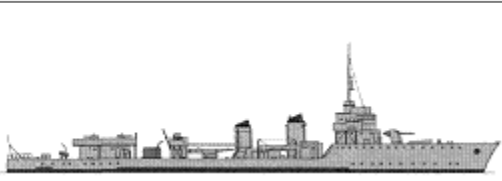
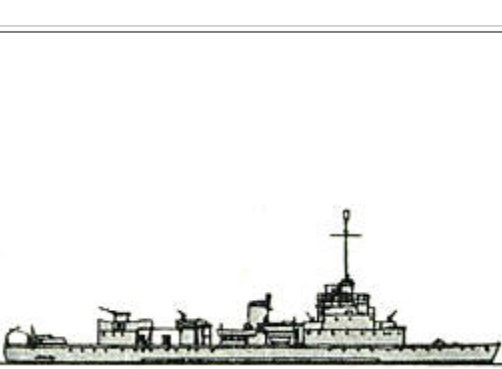
DD	1934A	2	T03	Kléber	1937		3110t, 121.3(03)-119.3(04)x11.3x4.2m, 6b,2gst, 70000hp, 38.2kts, 315p; 5x1-128/45(03), 4x1-128/45(04), 2x2-37/83(03), 4x2-37/69(04), 2x1- 37/57(04), (1x4+2x2+6x1)-20/65(03), (1x4+4x2+1x1)-20/65(04), 2x4- 533TT, 4dct, 60mines; radar, sonar
			T04	Desaix	1937		
	1936A	1	T02	Hoche	1940		3543t, 127.0x12.0x4.6m, 6b,2gst, 70000hp, 36kts, 332p; (1x2+2x1)-149/48, 2x2-37/83, 6x1- 37/57, (2x4+2x2)-20/65, 2x4-533TT, 4dct, 60mines; FuMO21 radar, sonar
	1936A(Mob)	1	T01	Marceau	1942		3691t, 127.0x12.0x3.9m, 6b,2gst, 70000hp, 36kts, 332p; 3x1-149/48, 1x1-105/45, 6x2-37/69, 2x1-37/57, (1x4+2x2)-20/65, 2x4-533TT, 4dct, 60mines; FuMO21 radar, sonar
	Alfredo Oriani	1	T15	D'Estaing	1937		2254t, 106.7x10.2x3.4m, 3b,2gst, 48000hp, 38kts, 206p; 2x2-120/50, 1x1-120/15, 2x1-37/54, 2x2-20/70, 8x1-20/65, 1x3-533TT, 4dct, 52mines; sonar
	Soldati	3	T12	Jurien de la Gravière	1942		2460t, 106.7x10.2x3.5m, 3b,2gst, 48000hp, 38kts, 206p; (2x2+1x1)-120/50(12,14), 2x2- 120/50(13), 3x1-37/54(13), 2x1- 37/54(14), (4x2+5x1)-20/65, 2x3- 533TT(12), 1x3-533TT(13,14), 4dct; EC.3/ter(13), FuMO21(14) radars, sonar
			T13	Duperré	1942		
			T14	Duchaffault	1942		
	1935	1	T10	Bir Hakeim	1940		1082t, 87.1x8.6x2.3m, 4b,2gst, 31000hp, 35kts, 119p; 1x1-105/45, 1x1-40/60, 2x1-37/57, (2x4+4x1)-20/65, 1x3-533TT, 2dct, 30mines; sonar
	1937	2	T09	Dompaire	1941		1098t, 85.2x8.9x2.5m, 4b,2gst, 31000hp, 35kts, 155p; 1x1-105/45, 2x1-37/57, (2x4+2x2)-20/65, 2x1-86 RAGM42/43 RL, 1x3-533TT(09), 2x3- 533TT(11), 2dct, 30mines; FuMO28 radar, sonar
T11			Baccarat	1942			
1939	2	T07	L'Alsacien	1942		1754t, 102.5x10.0x2.7m, 4b,2gst, 29000hp, 32.5kts, 206p; 4x1-105/45, 2x2-37/83, (3x4+3x1)-20/65(07), (1x4+2x2)-20/65(08), 2x3-533TT, 2dct, 50mines; FuMO21 radar, sonar	
		T08	Le Lorrain	1943			
		A32	La Pérouse	1943			





FF	Sans Souci	2	A33	Beautemps Beaupré	1942		2100t, 95.0x11.8x3.2m, 2d, 4140hp, 16.7kts, 178p; 2x1-105/45(32), 3x1-105/45(33), 2x2-37/83, 6x2-20/65
			Bougainville	A01	La Grandière	1940	
	A02	Dumont D'Urville		1932			
	A03	Savorgnan de Brazza		1932			
	DET	6	F01	Algérien	1944		1602t, 93.3x11.2x3.2m, 4dg,2em, 6000hp, 21kts, 186p; 3x1-76/50, 3x1-40/60, 10x1-20/70, 1x24-178 Hedgehog ASWRL, 8dct, 2dcr; SA, SU radars, sonar
			F02	Sénégalais	1943		
			F03	Somali	1944		
			F04	Hova	1944		
			F05	Marocain	1944		
			F06	Tunisien	1944		
	River	6	F07	L'Aventure	1944		2130t, 91.8x11.2x3.6m, 2b,2vte, 5500hp, 20kts, 140p; 2x1-105/45, (2x2+7x1)-20/70, 1x24-178 Hedgehog ASWRL, 8dct, 2dcr; type 272, 291 radars, sonar
			F08	La Surprise	1944		
F09			L'Escarmouche	1944			
F10			Croix de Lorraine	1943			
F11			Tonkinois	1943			
F12			La Découverte	1943			
Eritrea	1	A04	Francis Garnier	1937		3068t, 96.9x13.3x3.5m, 2d/2dg,2em, 9100hp, 20kts, 234p; 2x2-120/45, 2x2-37/54, 2x2-20/65	
La Melpomène	5	1	La Melpomène	1936		895t, 80.7x8.0x3.1m, 2b,2gst, 22000hp, 34.5kts, 105p; 1x1-100/45, 3x1-40/39, 2x1-20/70, 2x2-13.2, 1x2-550TT, 1dcr	
		2	La Flore	1936			
		3	L'Incomprise	1938			
		4	La Cordelière	1937			
		5	Bouclier	1938			
Élan	9	A11	Commandant Bory	1939		895t, 78.3x8.7x3.3m, 2d, 4000hp, 20kts, 106p; 1x1-105/45(15), 1x2-102/45(13,17), 1x2-90/50(11,12,14,16,18,19), 1x1-76/40(13), 1x1-40/60(15), 1x1-40/39(13,17), 1x1-25/60(17), 4x1-20/70(15), 2x1-20/70(17), (1x4+2x2)-13.2(11,12,14,16,18,19),	
		A12	Commandant Delage	1939			
		A13	La Moquese	1940			
		A14	La Gracieuse	1940			
		A15	Commandant Dominié	1940			
		A16	La Capricieuse	1940			

FS		A17	Commandant Duboc	1939		3x2-13.2(13), 4x2-13.2(17), (4x2+2x1)-12.7(15), 2dct, 1dcr	
		A18	La Boudeuse	1940			
		A19	Élan	1939			
	Chamois	6	A05	Bisson	1947		900t, 78.3x8.7x3.3m, 2d, 4000hp, 20kts, 106p; 2x1-105/45(05-07), 1x2-90/50(08-10), 1x1-40/60, 4x1-20/70(05-07), 6x1-20/70(08-10), 4dct, 2dcr
			A06	Commandant de Pimodan	1947		
			A07	Commandant Amyot d'Inville	1947		
			A08	Gazelle	1939		
			A09	Annamite	1940		
			A10	Chevreuil	1939		
	Amiral Mouchez	1	1	Amiral Mouchez	1937		970t, 62.0x10.3x3.4m, 1d, 800hp, 12kts, 81p; 2x1-100/45, 4x1-20/70, 2x1-13.2, 4dct, 2dcr; radar, sonar

PATROL AND COASTAL COMBATANTS

PC	34	W11	Sabre	1944		430t, 52.9x7.1x2.4m, 2d, 2880hp, 20kts, 65p; 1x1-76/50, 1x1-40/60, 5x1-20/70, 2x4-178 Mousetrap ASWRL, 2dct, 2dcr; SU radar, sonar
		W12	Cimeterre	1944		
		W13	Pique	1944		
		W21	Dague	1944		
		W22	Coutelas	1944		
		W23	Javelot	1944		
		W31	L'Eveillé	1941		
		W32	L'Indiscret	1942		
		W33	Le Résolu	1941		
		W34	L'Effronté	1942		
		W41	Le Rusé	1941		
		W43	L'Emorté	1942		
		W61	Le Volontaire	1942		
		W62	Le Vigilant	1942		
		W63	L'Attentif	1942		
		W81	Hussard	1943		
		W82	Légionnaire	1943		
		W83	Dragon	1942		
		W91	Goumier	1942		
		W92	Carabinier	1942		
W93	Fantassin	1942				
W101	Grenadier	1942				



		W102	Tirailleur	1942		
		W103	Voltigeur	1942		
		W111	Lancier	1943		
		W112	Franc Tireur	1942		
		W113	Mameluck	1942		
		W121	Lansquenet	1942		
		W122	Cavalier	1942		
		W123	Spahi	1942		
		PT2	Pnom-Penh	1944		
		PT3	Luang-Prabang	1944		
		1	L'Impétueux	1944		
Hippopotame	1	1	Hippopotame	1918	No picture	970t, 2b,1vte, 1800hp, 12kts; 2x1-75/35
Navarin	1	1	Malakoff	1918	No picture	640t, 1vte, 500hp, 11kts, 31p; 1x1-100/45
Pluvier	2	1	Gelinotte	1918	No picture	780t, 1vte, 750hp, 11kts
		2	Tourterelle	1918		
L'Ajacienne	3	P136	L'Ajacienne	1936		466t, 48.8x8.1x3.7m, 1b,1vte, 800hp, 10kts, 20p; 1x1-102/40, 4x1-13.2
		P138	La Toulonnaise	1934		
		P139	La Sétoise	1934		
Ch5	3	Q012	Bénodet	1940		137t, 37.1x5.7x2.0m, 2d, 1130hp, 15.5kts, 23p; 1x1-75/35, 1x1-40/39, 1x2-12.7, 4dct, 1dcr, sweeps
		Q014	Diélette	1940		
		Q021	Ch21	1946		
Ch41	2	Q041	Audierne	1940		160t, 37.4x5.5x2.4m, 2d, 1130hp, 15.5kts, 23p; 1x1-75/35, 1x1-40/39, 4dct, 1dcr
		Q043	Lavandou	1940		
		1	Ch5	1943		
		2	Ch6	1943		
		3	Ch51	1943		
		4	Ch52	1943		
		5	Ch61	1943		
		6	Ch62	1943		
		7	Ch71	1943		
		8	Ch72	1943		
		9	Ch81	1942		
		10	Ch82	1942		
		11	Ch83	1942		
		12	Ch84	1942		
		13	Ch85	1942		
		14	Ch91	1942		
		15	Ch92	1942		
		16	Ch93	1942		

SC	SC	48	17	Ch95	1942		138t, 33.8x5.2x1.9m, 2d, 2400-1000hp, 21-16kts, 27p; 1x1-40/60, 3x1-20/70, 2x4-178 Mousetrapp ASWRL, 2dct, 2dcr; SCR-517A radar, QC sonar					
			18	Ch96	1942							
			19	Ch101	1942							
			20	Ch102	1942							
			21	Ch103	1942							
			22	Ch104	1942							
			23	Ch105	1942							
			24	Ch106	1942							
			25	Ch107	1943							
			26	Ch111	1942							
			27	Ch112	1942							
			28	Ch113	1942							
			29	Ch114	1942							
			30	Ch115	1942							
			31	Ch121	1942							
			32	Ch122	1942							
			33	Ch123	1942							
			34	Ch124	1943							
			35	Ch125	1942							
			36	Ch126	1943							
			37	Ch131	1942							
			38	Ch132	1942							
			39	Ch133	1942							
			40	Ch134	1942							
			41	Ch135	1942							
			42	Ch136	1942							
			43	Ch141	1942							
			44	Ch142	1942							
			45	Ch143	1942							
			46	Ch144	1942							
			47	Ch145	1942							
			48	Ch146	1943							
			PT	VLT	2			1, 2	VLT1, 2	1945		94t, 30.4x5.9x1.8m, 6pe(3), 6200hp, 50kts, 18p; 2x1-40/60, 1x2-20/65, 2-550TT
			YP	VLT	2			1, 2	V120, 121	1945 - 1946		94t, 30.4x5.9x1.8m, 6pe(3), 6200hp, 50kts, 18p; 2x3-15.0
				Fairmile B	4			Ved.101	St-Ronan	1941		86t, 34.8x5.6x1.5m, 2pe, 1200hp, 18kts, 16p; 1x1-47/40, 1x1-20/70, 1dcr; type 286 radar, sonar
								Ved.102	St-Yves	1941		
								Ved.103	St-Guénolé	1941		
								Ved.104	St-Alain	1941		
			HDML		21			1 - 21	VP1, 3, 6, 8-16, 21-23, VP31 Palmyre, VP32 Baalbeck, VP41 Aventure, VP42 Revanche, VP71, 72, 81	1941 - 1945		54t, 22.0x4.8x1.4m, 2d, 260-300hp, 11-11.8kts, 10p; 2x1-20/70, 8dc

VP51	2	1, 2	VP51, 52	1943	No picture	48t, 15.9x4.4x1.6m, 2pe, 250hp, 12kts, 10p
------	---	------	----------	------	------------	--

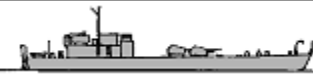

AMPHIBIOUS

LST	LST(2)	8	L9000	Liamone	1943		4080t, 100.0x15.2x4.3m, 2d, 1800hp, 11kts, 111p; (2x2+4x1)-40/60, 12x1-20/70; 4 LCVP, 20tanks, 163troops; radar
			L9001	Laïta	1943		
			L9002	Orne	1944		
			L9003	Vire	1943		
			L9004	Rance	1943		
			L9005	Odet	1944		
			L9006	Chélif	1944		
			L9007	Adour	1945		
LCU	MFP-D	3	1	MFP1	1945		239t, 49.8x6.6x1.4m, 3d, 375hp, 10.3kts, 21p; 1x1-88/45, 2x1-37/83, (1x4+2x1)-20/65; 3tanks
			2	MFP2	1945		
			3	MFP3	1946		
	LCI(L)	19	1	L101	1942		385-387t, 48.5-48.9x7.2x1.5-1.6m, 2d, 2320hp, 15.5kts, 24-29p; (4-5)x1-20/70; 180-209troops; SO radar
			2	L102	1942		
			3	L103	1943		
			4	L104	1943		
			5	L108	1942		
			6	L109	1942		
			7	L201	1942		
			8	L202	1943		
			9	L203	1942		
			10	L204	1942		
			11	L217	1942		
			12	L251	1942		
			13	L260	1942		
			14	L263	1942		
			15	LC1270	1943		
			16	LC1271	1943		
LCT(6)	4	1	LCT834	1944		320t, 36.3x10.0x1.2m, 3d, 675hp, 8kts, 13p; 2x1-20/70; 4tanks	
		2	LCT696	1944			
		3	LCT799	1944			
		4	LCT635	1944			
LCT(3)	5	1	LCT9083	1941/45		640t, 58.1x9.5x1.7m, 2pe or 2d, 920-1000hp, 10.5-11.5kts, 12p; 2x1-20/70; 5tanks	
		2	LCT9084	1941/45			
		3	LCT9085	1941/45			

									
			4	LCT9086	1941/45				
			5	LCT9091	1941/45				
	LCT(4)	15	1	LCT9060	1941/45		640t, 57.1x11.8x1.4m, 2d, 920hp, 10kts, 12p; 2x1-20/70; 6tanks		
					2			LCT9061	1941/45
					3			LCT9062	1941/45
					4			LCT9063	1941/45
					5			LCT9064	1941/45
					6			LCT9065	1941/45
					7			LCT9066	1941/45
					8			LCT9067	1941/45
					9			LCT9068	1941/45
					10			LCT9069	1941/45
					11			LCT9070	1941/45
					12			LCT9071	1941/45
					13			LCT9072	1941/45
					14			LCT9080	1941/45
					15			LCT9082	1941/45
LCF	LCG(M)	1	1	LCG9059	1944/45		380t, 47.1x6.8x2.1m, 2d, 1000hp, 11.7kts, 31p; 25sides, 51deck, 25turrets, 25CT; 2x1-88/27, 2x1-20/70		

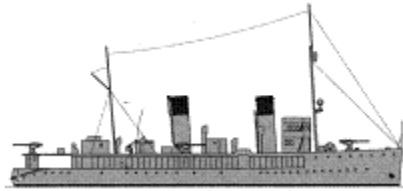
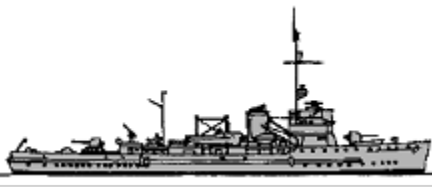
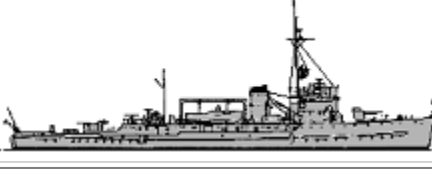
MINE WARFARE SHIPS

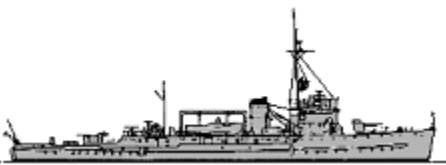

ML	Ilya Muromets	1	1	Pollux	1917		2463t, 64.2x15.5x6.0m, 6b,2vte, 4000hp, 14kts; 4x1-100/45, 2x1-37/50, 236mines
	1935	2	A20	Ailette	1941		874t, 68.1x8.7x2.1m, 2b,2se, 3500hp, 18.3kts, 84p; 2x1-105/45, 1x2-37/83, 2x1-20/65, 2dct, 30mines, sweeps
			A22	Somme	1939		
	1938	2	A23	Meuse	1941		908t, 71.0x8.7x2.1m, 2b,2se, 3200hp, 18.3kts, 97p; 2x1-105/45, 3x1-20/65, 2dct, 30mines, sweeps
			A29	Bapaume	1941		
MSO			A21	Ancre	1941		
			A24	Oise	1941		
			A25	Yser	1942		
			A26	Belfort	1941		

	1939(Mob)	8					878t, 68.4x9.2x2.1m, 2b,2se, 3700hp, 18.3kts, 119p; 2x1-105/45, 1x2-37/83, 2x1-20/65, 2dct, 30mines, sweeps
			A27	Péronne	1940		
			A28	Vimy	1941		
			A30	Laffaux	1941		
			A31	Craonne	1941		
	1940	2	1	Marne	1942		775t, 62.3x8.9x2.3m, 2b,2vte, 2615hp, 17.2kts, 75p; 2x1-105/45, 4x1-37/69, 1x4-20/65, 2x1-15.0, 2x1-86 RAgM42/43 RL, 4dct, 2dcr, 12mines, sweeps
			2	Suipe	1942		
MSC	YMS	28	D301	Amarante	1943		320t, 41.5x7.5x2.4m, 2d, 800hp, 14kts, 60p; 1x1-76/50, 2x1-20/70, 2dct, 2dcr, mechanical, magnetic, acoustic sweeping gear; SO radar
			D311	Anémone	1942		
			D312	Tiaré	1942		
			D313	Armoise	1942		
			D314	Asphodèle	1943		
			D315	Aubépine	1942		
			D316	Balsamine	1942		
			D317	Basilic	1942		
			D318	Belladone	1942		
			D321	Campanule	1942		
			D322	Capucine	1943		
			D323	Clématite	1942		
			D324	Lotus	1942		
			D325	Dahlia	1942		
			D326	Digitale	1942		
			D327	Gentiane	1942		
			D331	Géranium	1942		
			D333	Hortensia	1942		
			D334	Héliotrope	1942		
			D335	Jasmin	1942		
			D336	Jonquille	1942		
			D337	Marjolaine	1942		
			D351	Perce-Neige	1942		
			D352	Pimpernelle	1942		
			D353	Primevère	1942		
			D354	Pétunia	1943		
			D355	Genêt	1943		
			D356	Zinnia	1943		



[home](#)[World navies yesterday](#)[1950](#)

Greece 01 January 1950

SUBMARINES

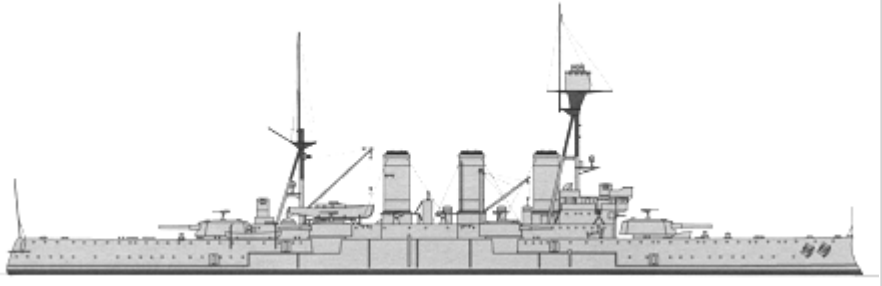

SS	U long hull	4	Y8	Pipinos	1943		660/740t, 62.3x4.9x4.7m, 2dg,2em, 615/825hp, 11.2/10kts, 33p, 90m; 1x1-76/45, 2x1-20/70, 4-533TT; type 291W(8), 267QW(9,14,15) radars, sonars
			Y9	Delfin	1944		
			Y14	Triaina	1944		
			Y15	Argonautis	1944		
U		2	Y10	Xifias	1943		646/732t, 60.0x4.9x4.7m, 2dg,2em, 615/825hp, 11.2/10kts, 33p, 60m; 1x1-76/45, 4-533TT; type 291W radar, sonars
			Y11	Amfitriti	1943		

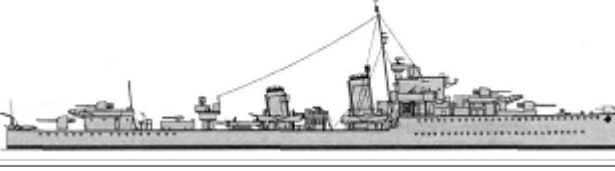
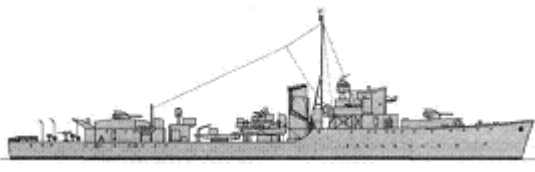
PRINCIPAL SURFACE COMBATANTS

CA	Averof	1	1	Averof	1911		10200t, 140.8x21.0x7.5m, 22b,2vte, 19000hp, 22.5kts, 670p; 200belt, 50deck, 140turrets, 180CT; 2x2-234/45, 4x2-190/45, 12x1-76/40, 6x1-20/65
DD	B	1	D78	Salamis	1931		1815t, 98.5x9.8x3.7m, 3b,2gst, 34000hp, 35.2kts, 138p; 3x1-120/45, 1x1-76/45, (2x2+2x1)-20/70, 1x4-533TT, 4dct, 2dcr; radar, type 119 sonar
	E	1	D63	Navarinon	1934		1940t, 100.3x10.1x3.8m, 3b,2gst, 36000hp, 36kts, 145p; 4x1-120/45, 1x1-76/45, (2x2+2x1)-20/70, 1x4-533TT, 2dct, 1dcr, sweeps; radar, type 121 sonar
FF	Hunt 2	5	L65	Pindos	1942		1590t, 85.3x9.6x3.7m, 2b,2gst, 19000hp, 27kts, 168p; 2x2-102/45, 1x4-40/39, 3x1-20/70, 1x2-533TT, 4dct, 2dcr; type 272, 285, 291 radars, type 123A, 127 sonars
			L81	Astings	1942		
			L53	Kanaris	1942		
			L91	Miaoulis	1942		
			D06	Adrias	1942		

Hunt 3	3	L51	Themistokles	1942		1625t, 85.3x9.6x3.8m, 2b,2gst, 19000hp, 27kts, 168p; 3x2-102/45, 1x4-40/39, 4x1-20/70, 2dct, 3dcr; type 271, 285, 291 radars, type 123A, 127 sonars
		L84	Kriti	1942		
		3	Aigaion	1941		
FS Flower 4	4	1	Kriezis	1940		1170t, 62.5x10.1x4.1m, 2b,1vte, 2750hp, 16.5kts, 109p; 1x1-102/45(1,4), 1x1-76/40(2,3), 1x1-40/39, 4x1-20/70, 2dct, 2dcr; type 286, 290 radars, sonar
		2	Apostolis	1940		
		3	Sakhtouris	1940		
		4	Tompazis	1941		

PATROL AND COASTAL COMBATANTS

PC	PGM9	6	1	Plotarchis Arsanoglu	1945		439t, 52.9x7.1x3.3m, 2d, 2880hp, 19kts, 65p; 1x1-76/50, 1x2-40/60, 6x1-20/70, 1x2-60/12mortar, 2x1-12.7; radar
			2	Antipliarchos Laskos	1944		
			3	Plotarchis Meletopoulos	1944		
			4	Plotarchis Blessas	1945		
			5	Antipliarchos Pezopoulos	1944		
			6	Plotarchis Chadzikonstandis	1944		
			PC451	1	1		
PB	Fairmile B	14	1-8	AF1032, 1051, 1149, 1221, 1252, 1292, 1307, 1375	1941-1943		86t, 34.8x5.6x1.5m, 2pe, 1200hp, 18kts, 16p; 1x1-40/60, 2x1-20/70, 2dct, 2dcr; type 291 radar, sonar
			AK295	Doliana	1941		
			AK307		1941		
			AK341		1941		
			AK478	Elefteron	1942		
			AK483	Kalambaka	1942		
			AK554	Kassos	1942		
			AK561	Karpatos	1942		
			AK565	Kos	1943		
			AK569	Tilos	1943		
			AK578		1943		
			AK580	Kastelorizo	1943		
			AK861		1944		
			AK864	Nisyros	1944		
			AK867		1944		
HDML	8	1-8				54t, 22.0x4.8x1.4m, 2d, 300hp, 11.8kts, 10p; 1x1-40/60, 1x1-20/70, 8dc; type 291 radar	

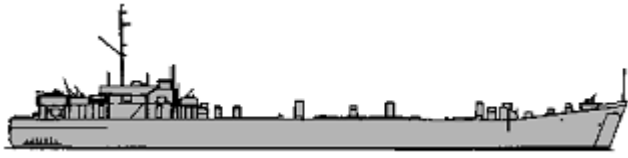
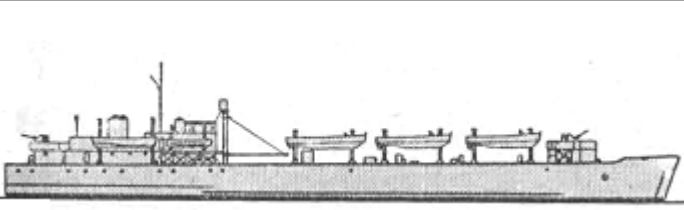
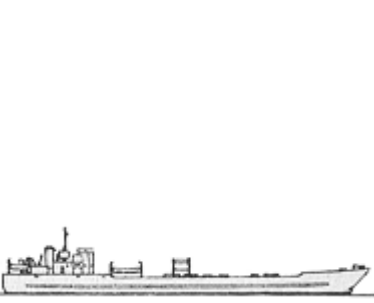

AMPHIBIOUS

LST(2)	3	1	Limnos	1943		4080t, 100.0x15.2x4.3m, 2d, 1800hp, 12.1kts, 125p; 1x1-76/50, 6x1-20/70; 4 LCVP, 20tanks, 153troops; radar
		2	Samos	1943		

LST	LST(3)	6	3	Chios	1943		
			L3002	Aliakmon	1945		4980t, 105.9x16.8x3.8m, 2b,2vte, 5500hp, 13.5kts, 111p; 2x2-40/60, (2x2+2x1)-20/70; 5 LCA, 1 LCT(6), 15tanks, 170troops; radar
			L3007	Axios	1945		
			L3020	Alfeios	1945		
			L3502	Strymon	1945		
			L3503	Achelaos	1945		
			L3506	Pyneos	1945		
LCU	LCT(4)	12	1	Kandanos	1943		640t, 57.1x11.8x1.4m, 2d, 920hp, 10kts, 12p; 2x1-20/70; 6tanks
			2	Sofades	1943		
			3	Vraghni	1943		
			4	Malakassi	1943		
			5	Palaiochori	1943		
			6	Komeno	1943		
			7	Kithera	1944		
			8	Serifos	1944		
			9	Anafi	1944		
			10	Thira	1944		
			11	Milos	1944		
			12	Amorgas	1944		
LC	LCA	13	1-13	EF1123, 1152, 1488, 1525, 1618, 1627, 1725, 1726, 1746, 1775, 1818, 1854, 1886	1940-1944	No picture	12t, 12.6x3.1x0.7m, 2pe, 130p, 8kts, 4p; 2x1-51/11 mortars; 40troops

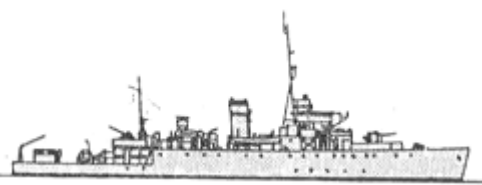
MINE WARFARE

MSO	Algerine	4	39	Navmachos	1943		1325t, 68.6x10.8x3.3m, 2b,2vte, 2400hp, 16.5kts, 138p; 1x1-102/45, 4x2-20/70, 4dct, 2dcr, sweeps; radar, sonar
			40	Polemistis	1943		
			41	Pyrpolitits	1943		
			42	Armatolos	1943		
			1	Kalymnos	1943		
			2	Aura	1943		
			3	Paxoi	1943		
			4	Ariadne	1943		
			5	Karteria	1943		
			6	Paralos	1943		
			7	Salaminia	1943		
			8	Lefkas	1943		
			9	Prokyon	1943		
			10	Vegas	1943		

MSC	YMS	23	11	Kleio	1943		320t, 41.5x7.5x2.4m, 2d, 800hp, 14kts, 60p; 1x1-76/50, 2x1-20/70, 2dct, 2dcr, sweeps; radar
			12	Kefallinia	1943		
			13	Kerkyra	1943		
			14	Lambadias	1943		
			15	Afroessa	1943		
			16	Leros	1943		
			17	Symi	1943		
			18	Zakynthos	1943		
			19	Pigassos	1943		
			20	Patmos	1943		
			21	Ithaki	1943		
			22	Thalia	1943		
			23	Andromeda	1943		
MMS1	7	1	Chimarra	1940		295t, 36.4x7.1x2.7m, 1d, 375-500hp, 10-11kts, 20p; 2x1-20/70, sweeps	
		2	Tepelini	1941			
		3	Mikonos	1941			
		4	Korytsa	1941			
		5	Argirokastro	1942			
		6	Andros	1944			
		7	Syros	1944			
MSI	APc	6	FT-11	Velestinon	1942	No picture	229t, 31.4x6.5x2.5m, 1d, 500hp, 10kts, 25p; 2x1-20/70, sweeps
			FT-12	Elasson	1942		
			FT-13	Kalavrita	1942		
			FT-15	Distomon	1942		
			FT-24	Lechovon	1942		
			FT-28	Anchialos	1942		

© Ivan Gogin, 2015

[home](#)[World navies yesterday](#)[1950](#)

Haiti 01 January 1950

COAST GUARD

PC	PC453	1	GC2	16 Août 1946	1941	No picture	100t, 33.5x5.5x1.8m, 2d, 1540hp, 17kts, 27p; 1x1-40/60, 2x1-20/70, 2dcr
	SC 110ft	2	GC3	Toussaint L'Overture	1943		136t, 33.8x5.5x2.0m, 2d, 2400hp, 21kts, 27p; 1x1-40/60, 3x1-20/70, 2x4-178 Mousetrap ASWRL, 2dct, 2dcr; radar, QC sonar
GC4			Amiral Killick	1943			
PB	USCG 83ft	6	Nr.1-6		1942		45t, 25.3x4.9x1.4m, 1200hp, 20.5kts, 10p; 1x1-20/70, 2x4-178 Mousetrap ASWRL, 4dcr; radar, sonar
	USCG	1	GC1	Savannah	1944	No picture	47t, 25.3x4.9x1.3m, 2d, 200hp, 9kts, 12p

© Ivan Gogin, 2016

[home](#)[World navies yesterday](#)[1950](#)

Hong Kong 01 January 1950

POLICE FORCE

PB	Snipe	8	PL9	Snipe	1946	No picture	28t, 13.7x4.6x2.1m, 1d, 144hp, 9kts, 5p
			PL10	Puffin	1946		
			PL11	Wren	1946		
			PL12	Mallard	1946		
			PL13	Gull	1946		
			PL14	Tern	1946		
			PL15	Cormorant	1946		
			PL16	Kestrel	1946		

© Ivan Gogin, 2016

[home](#)[World navies yesterday](#)[1950](#)

Hungary 01 January 1950

RIVER CRAFT

PGR	PM1	1	PN11	1949		38t, 28.0x3.7x1.1m, 2d, 420hp, 13.5kts, 16p; 13belt, 20deck, 30CT; 2x1-37/73, 1x1-82/11 mortar
MLB	AM1	1	AM3	1940		20t, 14.3x3.7x0.6m, 2d, 150hp, 11.6kts, 3p; 6mines or minesweeping gear
	AN1	2	AN1, 2	1948		12t, 13.4x3.8x0.6m, 2d, 220hp, 9kts, 7p; 1x1-12.7, 4mines or minesweeping gear or charge lines
MSB	GAM1	12	GAM1-12	1948	No picture	10t, 2d; 1x1-14.5, minesweeping gear

© Ivan Gogin, 2016

[home](#)[World navies yesterday](#)[1950](#)

Iceland 01 January 1950

COAST GUARD

APS	-	2	1	Esja	1939		1347brt, 10kts
			2	Ægir	1929		507t
APC	-	1	1	Hermoður	1947		208t
APB	-	2	1	Sæbjörg	1937		98t
			2	Óðinn	1938		72t

© Ivan Gogin, 2016

[home](#)

[World navies yesterday](#)

[1950](#)





India 01 January 1950

PRINCIPAL SURFACE COMBATANTS

CL	Leander	1	C78	Delhi	1933		9740t, 169.0x17.0x6.1m, 6b,4gst, 72000hp, 32.5kts, 680p; 76belt, 51deck, 25turrets; 3x2-152/50, 4x2-102/45, (4x2+6x1)-40/60, 2x4-533TT; type 274, 285, 277Q, 293, 960 radars
DD R		3	D115	Rana	1942		2424t, 109.2x10.9x4.3m, 2b,2gst, 40000hp, 36kts, 225p; 4x1-120/45, 4x1-40/60, 1x4-40/39, 2x2-20/70, 2x4-533TT, 4dct, 3dcr; type 272, 282, 285, 291, 293 radars, type 123A, 127 sonars
			D141	Ranjit	1942		
			D209	Rajput	1942		
Egret		2	U21	Jumna	1941		1758t, 89.2x11.4x3.3m, 2b,2gst, 3600hp, 19kts, 195p; 3x2-102/45, (2x2+2x1)-20/70(21), 4x1-20/70(95), 1x24-178 Hedgehog ASWRL(95), 4dct, 2dcr; type 272, 285, 291 radars, type 123A, 127 sonars
			U95	Sulej	1941		
FF	Black Swan	2	U10	Cauvery	1943		1950t, 91.3x11.7x3.5m, 2b,2gst, 4300hp, 219p; 3x2-102/45, 2x1-40/60(46), (4x2+2x1)-20/70, 8dct, 2dcr; type 272, 285, 291 radars, type 123A, 177 sonar
			U46	Kistna	1943		
River		2	K256	Tir	1943		2180t, 91.8x11.2x3.9m, 2b,2vte, 5500hp, 20kts, 140p; 1x1-102/40(256), 2x1-102/40(243), 1x1-40/60(256), 2x1-20/70(256), (4x2+2x1)-20/70(243), 1x24-178 Hedgehog ASWRL(243), 8dct(243), 2dcr(243); type 272, 291 radars, sonars
			K243	Khukri	1943		

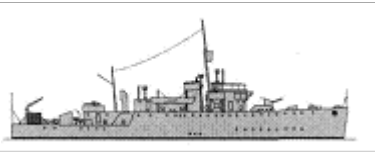
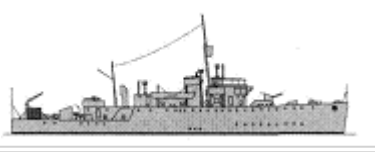
MINE WARFARE

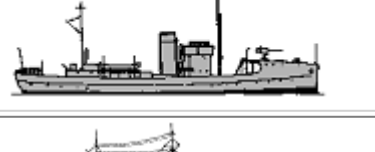
			J228	Konkan	1942	
--	--	--	------	--------	------	--

MSO	Bangor VTE	2	J197	Rajputana	1942		875t, 54.9x8.7x3.1m, 2b,2vte, 2400hp, 16.5kts, 87p; 1x1-76/45, 3x1-20/70, 4dct, 2dcr, sweeps, radar
	Bangor turbine	1	J180	Rohilkand	1943		780t, 53.0x8.7x3.0m, 2b,2gst, 2000hp, 16.5kts, 87p; 1x1-76/40, 3x1-20/70, 4dct, 2dcr, sweeps, radar
	Bathurst	3	J243	Bengal	1942		790t, 56.7x9.5x3.0m, 2b,2vte, 2000hp, 16kts, 90p; 1x1-76/40, 1x1-40/60, 2x1-20/70, 4dct, 2dcr, sweeps; radar
			J249	Bombay	1942		
			J237	Madras	1942		
Basset	3	T261	Amritsar	1942		775t, 50.0x8.4x3.4m, 1b,1vte, 950hp, 13kts, 48p; 1x1-76/40, 3x1-20/70, 2dct, 2dcr	
		T315	Cochin	1946			
		T258	Nasik	1945			
MSC	MMS1	2	1	MMS130	1943		295t, 36.4x7.1x2.7m, 1d, 500hp, 11kts, 20p; 2x1-20/70, sweeps
		2		MMS154	1946		

© Ivan Gogin, 2015

[home](#)

[World navies yesterday](#)

[1950](#)

Indonesia 01 January 1950

PATROL AND COASTAL COMBATANTS

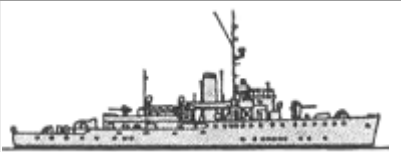
PS	Bathurst	2	256	Pati Oenoos	1942		790t, 56.7x9.5x3.0m, 2b,2vte, 2000hp, 16kts, 90p; 1x1-102/44, 1x1-40/60, 4x1-20/70, 4dct, 2dcr, minesweeping gear; radar, sonar
			257	Hang Toeah	1942		

© Ivan Gogin, 2016

[home](#)[World navies yesterday](#)[1950](#)

Iran 01 January 1950

PRINCIPAL SURFACE COMBATANTS

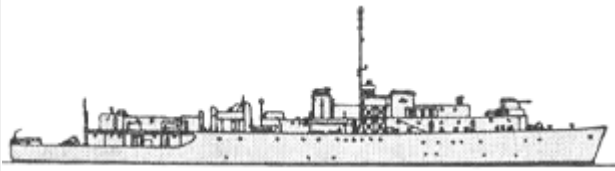
FF	Loch	1	1	Babr	1945		2260t, 93.6x11.8x3.8m, 2b,2vte, 5500hp, 19.5kts, 177p; 1x2-102/45, 4x1-40/60; type 277, 291 radars
----	------	---	---	------	------	--	--

PATROL AND COASTAL COMBATANTS

PC	Shahrokh	3	1	Shahrokh	1932		360t, 51.8ppx6.7x1.8m, 2d, 900hp, 15.5kts; 1x1-76/40, 1x1-20/70
			2	Shahbaz	1932		
			3	Simurgh	1932		
PB	Azerbaijan	3	1	Babolsar	1933	No picture	32t, 20.9x3.8x1.1m, 2d, 300hp, 14kts, 15p; 1x1-45/46, 1x1-12.7
			2	Gorgan	1933		
			3	Sefid-Rud	1933		

MINE WARFARE

MSO	Algerine	1	1	Palang	1942		1325t, 68.6x10.8x3.3m, 2b,2vte, 2400hp, 16.5kts, 138p; 2x1-102/45, 4x2-20/70, 4dct, 2dcr; radar, sonar
-----	----------	---	---	--------	------	--	--

© Ivan Gogin, 2016

[home](#)

[World navies yesterday](#)

[1950](#)

Iraq 01 January 1950

PATROL AND COASTAL COMBATANTS

PBR	Thornycroft	4	1-4		1937	No picture	67t, 30.5x5.2x0.9m, 2d, 280hp, 12kts; 1x1-94/12, 2x1-81/12 mortars
-----	-------------	---	-----	--	------	------------	--

© Ivan Gogin, 2016

[home](#)[World navies yesterday](#)[1950](#)

Ireland 01 January 1950

PRINCIPAL SURFACE COMBATANTS

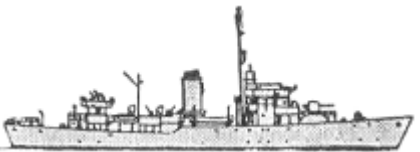
FS	Flower	3	P01	Macha	1942		1170t, 62.5x10.1x4.1m, 2b,1vte, 2750hp, 16.5kts, 109p; 1x1-102/45, 1x1-40/39(01,03), 2x1-20/70, 1x24-178 Hedgehog ASWRL(02,03), 2dct, 2dcr; type 286, 290 radars, sonar
			P02	Maev	1941		
			P03	Cliona	1941		

© Ivan Gogin, 2016



[home](#)[World navies yesterday](#)[1950](#)

Israel 01 January 1950

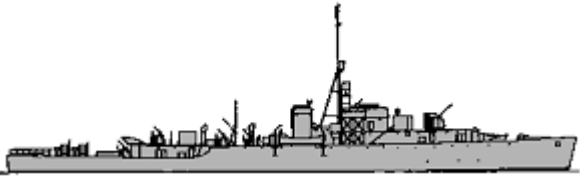
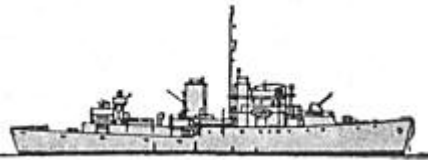
PRINCIPAL SURFACE COMBATANTS



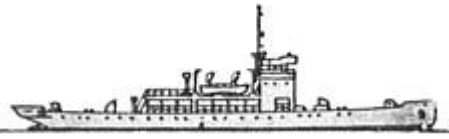
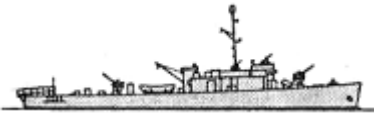

FF	River Canadian	1	K28	Mivtakh	1944		2180t, 91.8x11.2x3.9m, 2b,2vte, 5500hp, 20kts, 140p; 1x2-102/45, 1x1-76/40, 4x2-20/70, 1x24-178 Hedgehog ASWRL, 8dct, 2dcr; type 268, type 272, type 275, type 291 radars, sonars
FS	Flower mod.	2	K18	Wedgwood	1944		1370t, 63.5x10.1x4.4m, 2b,1vte, 2750hp, 16.5kts, 109p; 1x1-102/40, (2x2+2x1)-20/70, 1x24-178 Hedgehog ASWRL, 4dct, 2dcr; type 268, type 276 radars, sonar
			K20	Haganah	1943		

PATROL AND COASTAL COMBATANTS

PSO	Northland	1	A16	Eilath	1927		2150t, 66.0x11.9x4.2m, 2dg,1em, 1000hp, 11.5kts, 107p; 1x1-76/50, 10x1-20/70, 4dct; SC-1, SF radars, QCJ-3 sonar
PS	Argosy	1	K24	Maoz	1931	No picture	800t, 62.7x9.2x3.3m, 2d, 2060hp, 15kts, 74p; 1x1-76/50, 4x1-20/70; radar
	Gresham	1	K22	Hatikvah	1897	No picture	1190t, 62.6x9.8x3.4m, 4b,1vte, 2500hp, 17kts, 73p; 4x1-76/50
PC	PC 173ft	1	K26	Nogah	1944		463t, 52.9x7.1x3.3m, 2d, 2880hp, 19kts, 65p; 1x1-76/50, 1x1-40/60, 3x1-20/70, 2x4-178 Mousetrap ASWRL, 2dct, 2dcr; SO radar, sonar
PT	Higgins 78ft	1	T200	Netz	1944		48t, 24.0x6.1x1.6m, 3pe, 4500hp, 41kts, 17p; 1x1-40/60, 2x1-20/70, 4-533TT; SO radar
	Vosper 70ft	8	T201	Nasher	1944		47t, 22.3x5.9x1.3m, 3pe, 4200hp, 40kts, 16p; 1x1-40/60, 1x2-20/70, 2-450TT, 2dcr; type 291 radar
			T202	Ait	1944		
			T203	Ayah	1944		
			T204	Daya	1944		
			T209	Shaldag	1944		
			T210	Lilit	1944		
			T211	Yinshof	1944		

			T212	Tinshemett	1944			
PB	R	1	M31	Galia	1944	No picture	2d, 500hp, 14kts	
	Fairmile B	1	M17	HaPortzim	1942		86t, 34.8x5.6x1.5m, 2pe, 1200hp, 18kts, 16p; 3x1-20/70, 2dcr; type 286 radar, sonar	
	Moretta	1	M19	Palmach	1941	No picture	2d, 14kts; 2x1-20/70, 2dcr	
	HDML		3	M21	Dror	1943	No picture	54t, 22.0x4.8x1.4m, 2d, 320hp, 12kts, 12p; 2x1-20/70, 2dcr
				M23	Saar	1943		
M35				Tirza	1943			

AMPHIBIOUS

LSS	LCT(2)	2	1	Afal Pyakan	1941		460t, 48.8x9.5x2.1m, 3d, 1380hp, 11kts, 12p; 2x1-20/70; 3tanks
			F39	Gosh Atzion	1942		
	LCI(L)	2	F51	Ramat Rachel	1944		385t, 48.9x7.2x1.6m, 8d(2), 2320hp, 15.5kts, 29p; 5x1-20/70; 209troops; SO radar
			F53	Nitzanim	1944		
	MFP-D	2	F25	Iad Mordekhai	1944		239t, 49.8x6.6x1.4m, 3d, 375hp, 10.3kts, 21p; 1x1-20/70; 3tanks
			F33	Vavid Harvah	1944		
LCM	LCM(6)	6	1-6		1944		56t, 17.1x4.3x1.2m, 2d, 450hp, 9kts, 5p; 2x1-12.7; 1tank

MINE WARFARE



MSC	Whaler	2	Sh27	Drom Afrikha 1	1941	No picture	300t, 40.0x7.6x3.9m, 1b,1vte, 500hp, 10kts; 1x1-76/40, 1x1-20/70, 2dct
			Sh29	Drom Afrikha 2	1941		

© Ivan Gogin, 2016

[home](#)[World navies yesterday](#)[1950](#)



Italy 01 January 1950



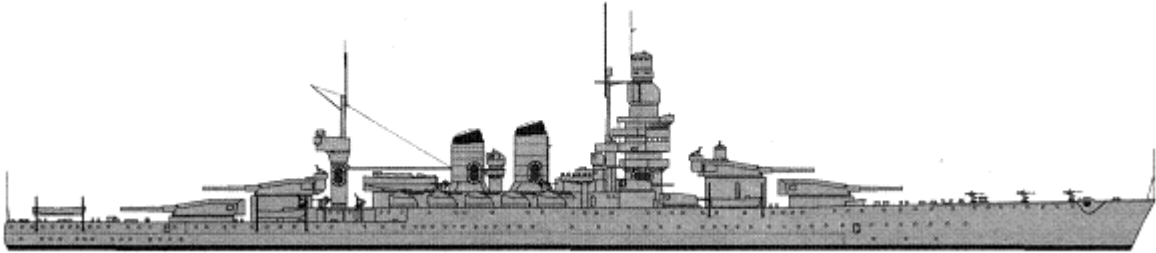
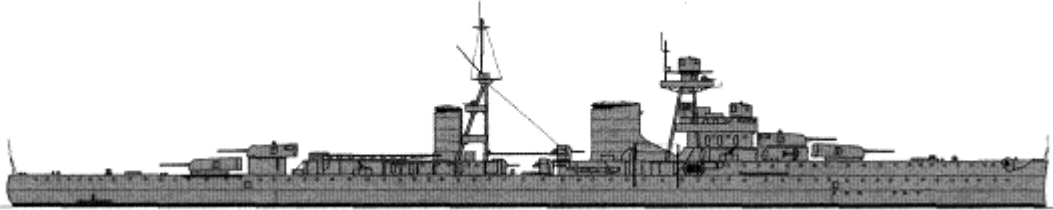
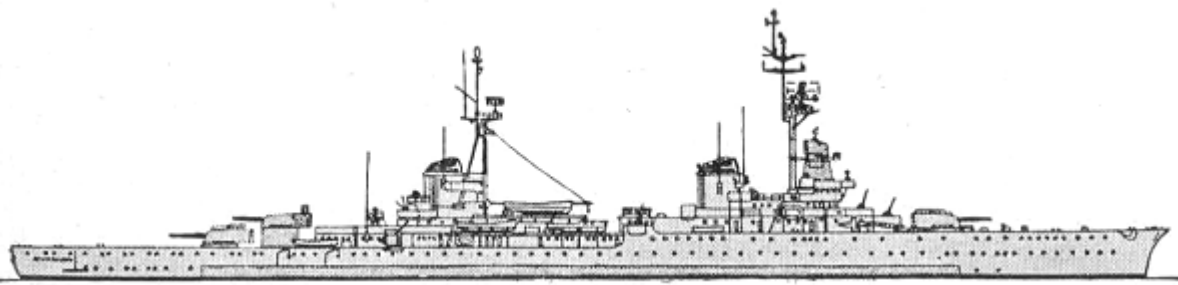

SUBMARINES

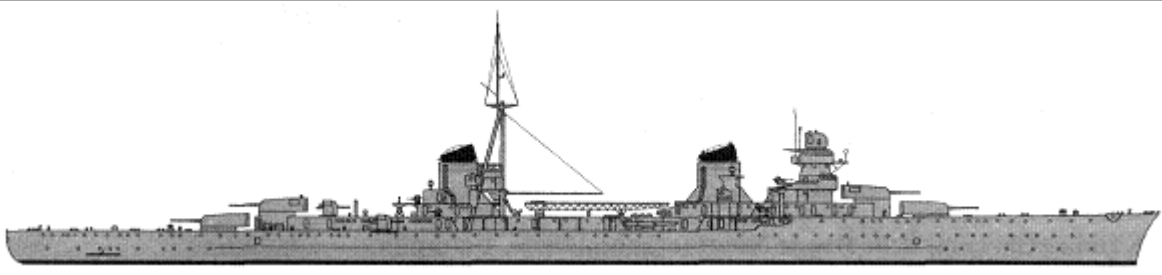
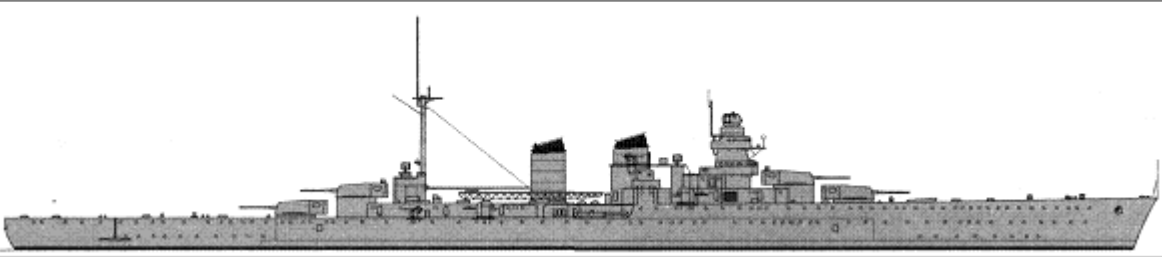
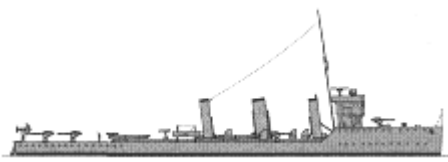
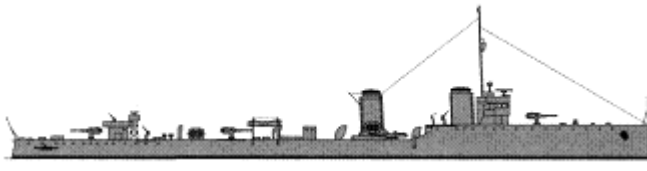
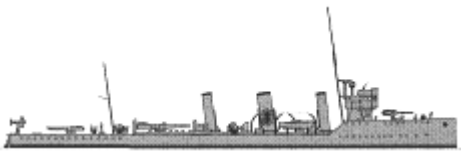
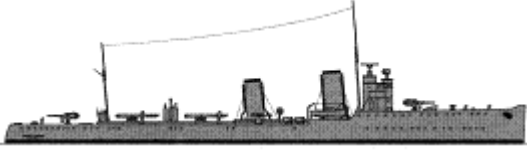
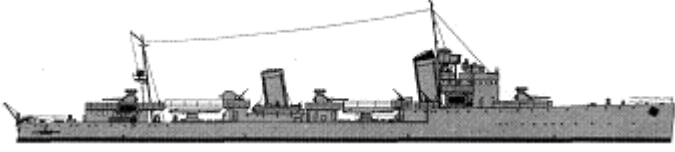
SS	Acciaio	1	1	PV2	1941		697/850t, 60.2x6.4x4.8m, 2d/em, 1400/800hp, 14/7.7kts, 45p, 80m; 1x1-100/47, 2x1-20/70, 6-533TT
	Flutto	1	1	PV1	1943		930/1093t, 63.2x7.0x4.9m, 2d/em, 2400/800hp, 16/8kts, 50p, 120m; 1x1-100/47, 2x1-20/70, 6-533TT

PRINCIPAL SURFACE COMBATANTS

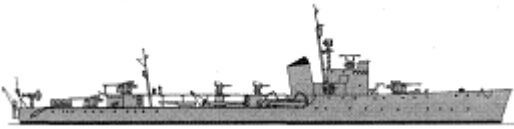
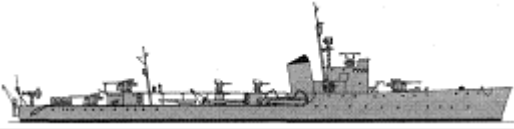



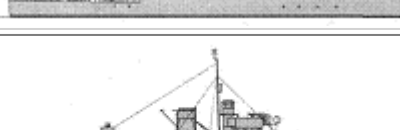

BB	Duilio	2	1	Andrea Doria	1916		28882(1)-29391(2)t, 186.9x28.6x9.1m, 8b,2gst, 87000hp, 28kts, 1485p; 250belt, 144decks, 280turrets, 260CT; (2x3+2x2)-320/44, 4x3-135/45, 10x1-90/50, 8x2-37/54, 6x2-20/65; EC.3/ter radar
			2	Caio Duilio	1915		
CL	Condottieri batch 2	1	1	Luigi Cadorna	1933		7001t, 169.3x15.5x5.5m, 6b,2gst, 95000hp, 36.5kts, 544p; 42belt, 20decks, 40turrets, 70CT; 4x2-152/53, 3x2-100/47, 4x1-20/70, 4x2-20/65, 2dct, 138mines
	Condottieri batch 3	1	1	Raimondo Montecuccoli	1935		8994t, 182.2x16.6x5.4m, 4b,2gst, 75000hp, 37kts, 650p, 85belt, 30decks, 70turrets, 100CT; 3x2-152/53, 2x2-100/47, 4x2-40/60, 4x1-20/70, 2dct, 146mines; SPS-6, SPS-12 radars
	Condottieri			Eugenio di			10672t, 186.9x17.5x6.5m, 6b,2gst, 110000hp, 36.5kts, 694p; 105belt, 35decks, 90turrets, 100CT; 4x2-152/53,

	batch 4	1	1	Savoia	1936		3x2-100/47, 4x2-37/54, 12x1-20/70, 2dct, 146mines; EC.3/ter radar	
	Condottieri batch 5	2	1	Luigi di Savoia Duca degli Abruzzi	1937		11575(1)-11117(2)t, 187.0x18.9x6.8m, 8b,2gst, 100000hp, 34kts, 692p; 130belt, 55decks, 135turrets, 140CT; (2x3+2x2)-152/55, (4x2+2x1)-100/47, 4x2- 37/54, (4x2+2x1)-20/65, 120mines; type 281(1), type 286 radars	
			2	Giuseppe Garibaldi	1937			
DD	Rosolino Pilo	3	1	Rosolino Pilo	1915		912t, 73.0x7.3x2.3m, 4b,2st, 16000(1,2)-14800(3)hp, 30(1,2)-29(3)kts, 79p; 2x1-102/35, 6x1-20/65, 2x1- 450TT, 2dct, 10mines	
			2	Giuseppe Cesare Abba	1915			
			3	Antonio Mosto	1915			
		Carlo Mirabello	1	1	Augusto Riboty	1917		1972t, 103.4x9.7x3.3m, 4b,2st, 44000hp, 35kts, 169p; 4x1-102/45, 6x1-20/70, 2dct, 120mines
		Giuseppe La Masa	2	1	Giacinto Carini	1917		851t, 73.5x7.3x2.8m, 4b,2st, 15500hp, 30kts, 78p; 1x1- 102/45(1), 2x1-102/45(2), 4x2-20/65(1), 6x1-20/65(2), 1x3-533TT(1), 1x2-450TT, 2dct(2), 10mines
				2	Nicola Fabrizi	1918		
		Curtatone	1	1	Monzambano	1924		1214t, 84.7x8.0x2.9m, 4b,2st, 22000hp, 32kts, 117p; 1x2-102/45, 3x2-20/70, 1x2-533TT, 16mines
		Navigatori	1	1	Nicoloso da Recco	1930		2580t, 107.3x10.2x3.4m, 4b,2gst, 50000hp, 38kts, 224p; 3x2-120/50, 2x1-37/54, 2x1-20/70, 7x1-20/65, 1x2- 533TT, 4dct
		Maestrale	1	1	Grecale	1934		2207t, 106.7x10.2x3.3m, 3b,2gst, 44000hp, 38kts, 190p; 2x2-120/50, 3x1-37/54, 2x1-20/65, 1x3-533TT, 4dct, 52mines
	Soldati group 1	3	1	Carabiniere	1938		2460t, 106.7x10.2x3.5m, 3b,2gst, 48000hp, 38kts, 206p; (2x2+1x1)-120/50(1), 2x2-120/50(2,3), 1x1-120/15(3), 2x1-37/54, (4x2+4x1)-20/65, 1x3-533TT, 4dct, 48mines	
			2	Fuciliere	1939			
			3	Granatiere	1939			



FF	Spica/Climene	1	1	Cassiopea	1937		995t, 80.4x8.2x3.1m, 2b,2gst, 19000hp, 34kts, 99p; 3x1-100/47, 4x1-20/70, 3x2-20/65, 2x2-450TT, 4dct, 28mines
	Spica/Perseo	2	1	Sagittario	1936		1005t, 80.4x8.2x3.1m, 2b,2gst, 19000hp, 34kts, 99p; 3x1-100/47, 4x1-20/70, 3x2-20/65, 2x2-450TT, 4dct, 28mines
			2	Sirio	1936		
	Spica/Alcione	4	1	Aretusa	1938		1035t, 80.4x7.9x3.1m, 2b,2gst, 19000hp, 34kts, 99p; 3x1-100/47, 4x1-20/70, 3x2-20/65, 2x2-450TT, 4dct, 28mines
			2	Calliope	1938		
3			Clio	1938			
4			Libra	1938			
Pegaso	2	1	Orione	1938		1575t, 89.3x9.7x3.7m, 2b,2gst, 16000hp, 28kts, 168p; 2x1-100/47, 3x1-20/70, 4x2-20/65, 2x2-450TT, 6dct	
		2	Orsa	1938			
FS	Gabbiano	19	1	Ape	1943		728t, 64.4x8.7x2.5m, 2d/em, 3500/300hp, 18/6kts, 110p; 1x1-100/47, 3x1-20/70, 2x2-20/65, sweeps
			2	Baionetta	1943		
			3	Chimera	1943		
			4	Cormorano	1943		
			5	Danaide	1943		
			6	Driade	1943		
			7	Fenice	1943		
			8	Flora	1943		
			9	Folaga	1943		
			10	Gabbiano	1942		
			11	Gru	1943		
			12	Ibis	1943		
			13	Minerva	1943		
			14	Pellicano	1943		
			15	Pomona	1943		
			16	Scimitarra	1943		
			17	Sfinge	1943		
			18	Sibilla	1943		
			19	Urania	1943		
Algerine	1	1	Eritrea	1943		1258t, 68.6x10.8x3.1m, 2b,2vte, 2400hp, 16.5kts, 138p; 1x1-100/47, 4x1-37/54, 4dct, 2dcr	
Flower	1	1	Elbano	1943		1375t, 63.5x10.1x4.5m, 2b,1vte, 2800hp, 16kts, 90p; 2x1-76/50, 4x1-20/70, 1x24-178 HedgehogASWRL, 4dct, 2dcr	

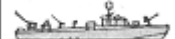



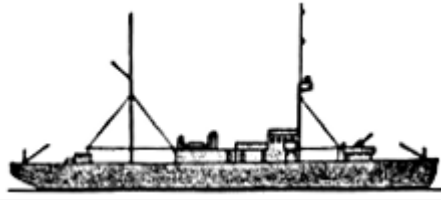
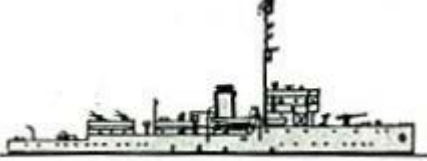

Andrea Bafile	1	1	Ernesto Giovannini	1922		284t, 52.1ppx5.7x1.8m, 2b,2vte, 2400hp, 24kts, 53p; 2x1-102/35, 1x1-13.2, 1x2-450TT, 2dcr
---------------	---	---	-----------------------	------	---	--

PATROL AND COASTAL COMBATANTS

PT	MAS501	5	MAS1-3, 9, NE109	1937		21-24t, 17.0x4.4-4.7x1.3m, 2pe, 2000hp, 41-42kts, 9p; 1x1-13.2
	MAS526	3	MAS5-7	1939		26t, 18.7x4.7x1.5m, 2pe/em, 200/140hp, 42/6kts, 10p; 1x1-13.2, 2-450TT
	MAS555	1	MAS8	1941		28t, 18.7x4.7x1.5m, 2pe/em, 2300/140hp, 43/6kts, 13p; 1x1-20/65, 2-450TT
	MS11	3	MV611-613	1942		63-64t, 28.0x4.3x1.6m, 3pe, 3450hp, 32kts, 19p; 2x1-20/65
	MS51	6	MV614-619	1943		66t, 28.0x4.3x1.6m, 3pe, 3450hp, 31kts, 19p; 3x2-20/65
	Higgins	6	GIS0021-0023, 0025-0027	1942 - 1943		48t, 24.0x6.1x1.6m, 3pe, 4500hp, 41kts, 17p; 1x1-40/60, 3x1-20/70, 2-450TT; SCR-517A radar
	Vosper	12	GIS0001-0008, 0011, 0013, 0017, 0028	1943 - 1944		45t, 22.1x5.9x1.7m, 3pe, 3375hp, 39kts, 12p; 5x1-20/65, 2-450TT; SCR-517A radar
PB	MAS438	2	ME38, 41	1934 - 1935	No picture	41t, 22.5x4.3x1.4m, 2pe, 2000hp, 32kts, 19p; 1x1-13.2, dc

MINE WARFARE SHIPS

ML	Fasana	1	1	Fasana	1925		590t, 66.3x9.8x1.7m, 2d, 700hp, 10kts, 66p; 1x1-76/40, 54mines, mechanical sweeps
	Ostia	1	1	Azio	1928		850t, 62.2x8.7x2.6m, 2b,2vte, 1500hp, 15kts, 66p; 2x1-102/35, 1x1-76/40, 80mines
	Dance	4	1	DR307	1941		770t, 50.0x8.4x3.4m, 1b,1vte, 850hp, 12.2kts, 40p; 1x1-102/45, 3x1-20/70, 2dct, 2dcr, mechanical sweeps
			2	DR308	1941		
			3	DR312	1940		
			4	DR316	1940		
	Shakespearian	1	1	DR310	1941		770t, 50.0x8.4x3.4m, 1b,1vte, 850hp, 12.2kts, 40p; 1x1-76/40, 3x1-20/70, 4dct, 2dcr, mechanical sweeps
			1	DR301	1941		
			2	DR302	1941		
			3	DR303	1942		
			4	DR304	1942		
			5	DR305	1942		

MSO	Isles	11	6	DR306	1942		770t, 50.0x8.4x3.4m, 1b,1vte, 850hp, 12.2kts, 40p; 1x1-76/40, 3x1-20/70, 4dct, 2dcr, mechanical sweeps
			7	DR309	1943		
			8	DR311	1942		
9			DR313	1942			
10			DR314	1942			
11			DR315	1942			
	type 1940	1	1	B1	1944		775t, 62.3x8.9x2.3m, 2b,2vte, 2615hp, 17.2kts, 75p; 1x1-105/45, (1x2+2x1)-37/83, (1x4+2x1)-20/65, 4dct, 2dcr, 12mines, mechanical, acoustic, magnetic sweeps
	type 1943	2	1	B2	1945		821t, 67.8x9.0x2.3m, 2b,2vte, 2700hp, 17kts, 96p; 2x1-105/45, 2x1-37/57, (1x4+2x1)-20/65, 2-533TT, 4dct, 24mines, mechanical, acoustic, magnetic sweeps
2			B3	1944			
MSB	YMS	17	1	Anemone	1942		250t, 41.5x7.5x2.4m, 2d, 800hp, 15kts, 60p; 1x1-76/50, 2x1-20/70, mechanical, acoustic, magnetic sweeps
			2	Azalea	1943		
			3	Begonia	1943		
			4	Biancospino	1942		
			5	Dalia	1943		
			6	Fiordaliso	1943		
			7	Gardenia	1943		
			8	Geranio	1942		
			9	Magnolia	1943		
			10	Mughetto	1942		
			11	Narciso	1942		
			12	Oleandro	1942		
			13	Orchidea	1943		
			14	Primula	1943		
			15	Tulipano	1943		
			16	Verbena	1943		
			17	Gladiolo	1943		
MCI	RD	4	1	RD32	1919		203-207t, 36.5x5.8x2.2m, 750-860hp, 13-14kts, 1x1-76/40, mechanical sweeps
			2	RD34	1919		
			3	RD40	1920		
			4	RD41	1920		
	VAS201	7		VAS492-494, 711, 712, 715, 716	1942		68-69t, 28.0x4.3x1.4m, 3pe, 1800hp, 20kts, 26p; 2x1-20/65, 2-450TT, mechanical sweeps
	VAS231	5		VAS495, 496, 723, 725, 726	1942 - 1943		69t, 28.0x4.7x1.3m, 3pe, 1750hp, 21.5kts, 26p; 2x1-20/65, 2-450TT, mechanical sweeps
	Vedetta	2		Vedetta, Vigilante	1937	No picture	70t, 26.1x4.3x1.3m, 2d, 400hp, 12kts, 21p; 1x1-76/40, 3x1-13.2, mechanical sweeps

MSB	RDV	16	1	DV111	1949	No picture	110t, 34.0x5.8x1.4m, 2pe(1-5,7-16)-2d(6) 2300(1-5,7-16)-2000(6)hp, 17kts, 24p; 1x1-20/65, mechanical sweeps
			2	DV112	1949		
			3	DV113	1945		
			4	DV114	1949		
			5	DV115	1949		
			6	DV116	1945		
			7	DV121	1949		
			8	DV122	1949		
			9	DV123	1949		
			10	DV124	1949		
			11	DV125	1946		
			12	DV131	1949		
			13	DV132	1949		
			14	DV133	1949		
			15	DV134	1949		
			16	DV135	1949		

AMPHIBIOUS

LCU	MZ-A	6	1	MZ722	1942		239t, 47.0x6.5x1.0m, 3d, 450hp, 11kts, 13p; 1x1-76/40, 2x1-20/65; 200men
			2	MZ726	1942		
			3	MZ728	1942		
			4	MZ729	1942		
			5	MZ737	1942		
			6	MZ758	1942		
	MZ-B	3	1	MZ776	1943		279t, 46.5x6.5x1.0m, 3d, 450hp, 11kts, 13p; 1x1-76/40, 2x1-20/65; 200men
			2	MZ784	1943		
			3	MZ800	1943		
	MFP-A,C	4	1	MZ360	1942		220t, 47.0x6.5x1.5m, 3d, 390hp, 10.5kts, 21p; 1x1-37/83, 2x1-20/65; 3tanks
			2	GLS435	1942		
			3	GLS436	1943		
			4	GLS437	1942		
	MFP-D	3	1	MZ831	1943		239t, 49.8x6.6x1.4m, 3d, 375hp, 10.3kts, 21p; 1x1-37/83, 2x1-20/65; 3tanks
			2	MZ1155	1944		
			3	MZ1191	1944		
	MFP-DM	3	1	MZ943	1944		256t, 49.8x8.6x1.4m, 3d, 390hp, 8kts, 21p; 1x1-37/83, 2x1-20/65; 3tanks
			2	MZ1045	1944		
			3	MZ1046	1945		
	LCT(2)	1	1	MZ34	1942		460t, 48.8x9.5x1.6m, 3d, 1380hp, 11kts, 12p; 2x1-20/70; 3tanks



	LCT(3)	1	1	GLS438	1942		640t, 58.5x9.5x1.7m, 2d, 1000hp, 10.5kts, 12p; 4x1-20/70; 5tanks
--	--------	---	---	--------	------	---	--

© Ivan Gogin, 2015

[home](#)[World navies yesterday](#)[1950](#)

Japan 01 January 1950



MINE WARFARE

MSC	Pa1	11	MS18	Pa31	1945		285t, 29.8x6.1x2.5m, 1d, 400hp, 9kts; 1x1-40/60, 6x1-25/60, minesweeping gear; 13-go radar
			MS19	Pa84	1945		
			MS20	Pa134	1945		
			MS21	Pa135	1945		
			MS22	Pa136	1945		
			MS23	Pa138	1945		
			MS24	Pa139	1945		
			MS25	Pa152	1945		
			MS26	Pa153	1945		
			MS28	Pa175	1945		
			MS29	Pa179	1945		
MSI	Cha1	18	MS01	Cha171	1944		135t, 29.2x5.7x2.0m, 1d, 400hp, 11kts, 32p; 1x1-13.2, minesweeping gear
			MS02	Cha221	1944		
			MS03	Cha222	1944		
			MS04	Cha241	1944		
			MS05	Cha246	1945		
			MS06	Cha249	1944		
			MS07	Cha72	1943		
			MS08	Cha79	1944		
			MS09	Cha86	1943		
			MS10	Cha88	1944		
			MS11	Cha90	1944		
			MS12	Cha93	1944		
			MS13	Cha99	1944		
			MS14	Cha202	1944		
			MS15	Cha214	1944		
			MS16	Cha215	1944		
			MS17	Cha231	1944		
			MS57	Cha168	1944		

	200t ARV	1	MS62	No1090	1939		189t, 38.5x5.9x1.9m, 2d, 800hp, 14kts; 1x1-13.2, minesweeping gear
MDV	-	2	MS31		1944		6888brt
			MS32	Soei	1944		4300dwt, 99.1x13.8x6.1m, 2b,1gst, 1100hp, 11.5kts

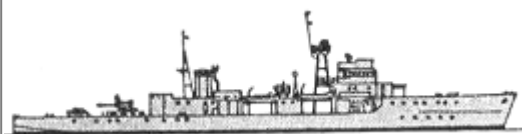
MARITIME SAFETY AGENCY

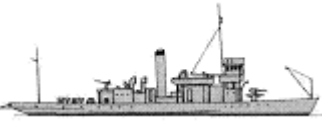
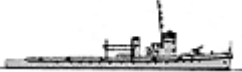

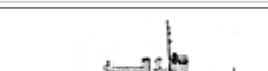
PSO	Ukuru	5	PL102	Ikuna	1944		1020t, 78.8x9.1x3.1m, 2d, 4200hp, 19.5kts, 150p; 1x1-76/50, 2x1-20/70; 22-go, 13-go radars
			PL103	Chikubu	1944		
			PL104	Ukuru	1944		
			PL105	Shinnan	1944		
			PL106	Shiga	1945		
			PC	Cha1	38		
PS02	Cha198	1944					
PS03	Cha245	1944					
PS04	Cha187	1944					
PS05	Cha227	1944					
PS06	Cha154	1944					
PS07	Cha217	1944					
PS08	Cha80	1943					
PS09	Cha232	1944					
PS10	Cha239	1945					
PS11	Cha169	1944					
PS12	Cha183	1944					
PS13	Cha186	1944					
PS14	Cha219	1944					
PS15	Cha236	1944					
PS16	Cha181	1944					
PS17	Cha166	1944					
PS18	Cha1	1943					
PS19	Cha185	1944					
PS20	Cha4	1943					
PS21	Cha57	1943					
PS22	Cha203	1944					
PS23	Cha27	1943					
PS24	Cha161	1944					
PS25	Cha196	1944					
PS26	Cha155	1944					
PS27	Cha68	1943					
PS28	Cha78	1943					
PS32	Cha58	1943					

			PS37	Cha157	1944		
			PS38	Cha159	1944		
			PS39	Cha71	1943		
			PS40	Cha173	1944		
			PS41	Cha179	1944		
			PS42	Cha194	1944		
	300t ARV	8	PS16	No...	1946		296t, 45.1x6.8x2.3m, 2d, 800hp, 14kts; 1x1-25/60
			PS45	No1338	1941		
			PS46	No1332	1940		
			PS44	No1540	1944		
			PS48	No1341	1941		
			PS56	No1538	1942		
			PS60	No1541	1943		
				No1336	1940		
	Sokuten	1	PS29	Katoku	1916		435t, 45.7x7.6x2.3m, 1b,1vte(2), 600hp, 12.8kts, 40p; 2x1-76/40
	150t(1934) ARV	1	PS43	No902	1934		141t, 37.8x5.2x1.7m, 2d, 520hp, 13kts; 1x1-25/60
	200t ARV	2	PS49	No1089	1939		189t, 38.5x5.9x1.9m, 2d, 800hp, 14kts; 1x1-25/60
			PS58	No1264	1940		
	150t(1933) ARV	1	PS50	No870	1933		145t, 40.1x5.6x1.3m, 2d, 520hp, 13kts; 1x1-25/60
	100t ARV	1	PS61	No873	1933		118t, xx1,5m, 2d, 520hp, 13kts; 1x1-25/60
PB	Soyokaze	11	CL01	Soyokaze	1949	No picture	22t, 15.0x4.2x0.6m, 2d, 330hp, 15.8kts, 6p
			CL02	Okikaze	1949		
			CL03	Umikaze	1949		
			CL04	Kawakaze	1949		
			CL05	Yamakaze	1949		
			CL06	Minekaze	1949		
			CL07	Nokaze	1949		
			CL08	Tanikaze	1949		
			CL09	Sawakaze	1949		
			CL10	Numakaze	1949		
			CL11	Hatsukaze	1949		

[home](#)[World navies yesterday](#)[1950](#)

North Korea 01 January 1950

PATROL AND COASTAL COMBATANTS

PT	G-5	5	1-5	1933-1944		20t, 19.1x3.4x1.0m, 2pe, 2000hp, 51kts, 7p; 2x1-12.7, 2-533TT
PB	OD-200	2	1, 2	1945		47t, 23.4x4.0x1.8m, 2pe/2pe, 2400/170hp, 24kts, 21p; 1x1-37/63, 2x1-12.7, 2dcr

© Ivan Gogin, 2016

[home](#)[World navies yesterday](#)[1950](#)

South Korea 01 January 1950

PATROL AND COASTAL COMBATANTS

PC	IJN SAR	2	313	Chungmugong I	1947		296t, 45.1x6.8x2.3m, 2d, 800hp, 13kts, 37p; 1x1-25/60
			315	Chungmugong II	1947		

AMPHIBIOUS

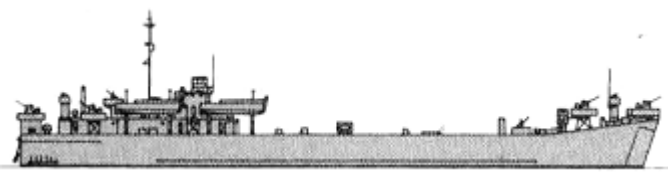
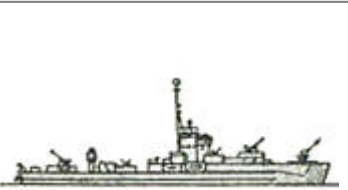
LST	LST(2)	4	1	Munsan	1943		4080t, 100.0x15.2x4.3m, 2d, 1800hp, 10kts, 70p; (2x2+4x1)-40/60, 2x1-20/70; 4 LCVP, 20tanks, 163troops; 2 radars
			2	Danyang	1943		
			3	Ulsan	1944		
			801	Cheonan	1944		
LSF	LCI(G/M)	6	101	Seoul	1944		385t, 48.9x7.2x1.8m, 8d(2), 2320hp, 15.5kts, 53-70p; (1-3)x1-40/60, (0-3)x1-20/70, (0-6)x1-12.7, (8-24)x1 Mk 7 RL or 3x1-107/10mortars; radar
			102	Jinju	1943		
			103	Chuncheon	1944		
			104	Cheongju	1944		
			105	Cheongjin	1944		
			106	Jinnampo	1944		

MINE WARFARE

MSC	YMS	15	501	Gangjin	1943		320t, 41.5x7.5x2.4m, 2d, 800hp, 14kts, 60p; 1x1-76/50, 2x1-20/70, 2dct, 2dcr; mechanical, magnetic, acoustic minesweeping gear; radar
			502	Gyeongju	1943		
			503	Gwangju	1944		
			504	Gaeseong	1942		
			505	Gimhae	1943		
			506	Ganggye	1943		
			507	Gangneung	1944		
			509	Gapyeong	1943		
			510	Ganggyeong	1943		
			512	Guwolsan	1943		
			513	Gimcheon	1944		

			514	Gilju	1942		
			515	Goryeong	1943		
			516	Gonju	1943		
			518	Goseong	1942		
MSI	Cha	10	301	Daejeon	1944		135t, 29.2x5.7x2.0m, 1d, 400hp, 11kts, 32p; 1x1-25/60, mechanical, magnetic minesweeping gear
			302	Tongyeong	1944		
			303	Daegu	1944		
			304	Taebaeksan	1944		
			305	Dumangang	1944		
			306	Danyang	1944		
			307	Dancheon	1944		
			308	Toseong	1944		
			309	Daedonggang	1944		
			310	Deokcheon	1944		

© Ivan Gogin, 2016

[home](#)[World navies yesterday](#)[1950](#)

Malaysia 01 January 1950

PATROL AND COASTAL COMBATANTS

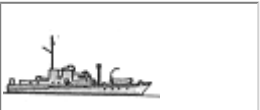
PB	HDML	3	P3501	Sri Kedah	1941		54t, 22.0x4.8x1.4m, 2d, 300hp, 11.8kts, 10p; 2x1-20/70, 2dcr; type 291 radar
			P3502	Sri Trengganu	1943		
			P3509	Sri Selangor	1943		

MINE WARFARE

ML	Wakataka	1	1	Laburnum	1941		1890t, 86.0x11.3x4.4m, 3b,2gst, 6000hp, 20kts, 199p; 2x1-76/40, 2x2-25/60, 4x1-13.2, 360mines, 4dct
----	----------	---	---	----------	------	--	---

© Ivan Gogin, 2016



[home](#)[World navies yesterday](#)[1950](#)

Mexico 01 January 1950

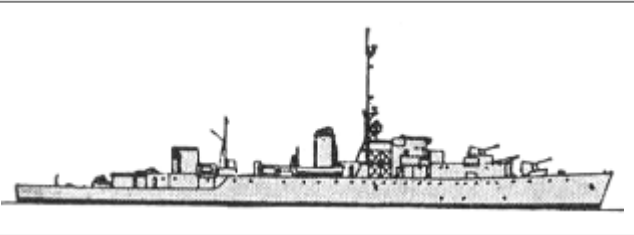
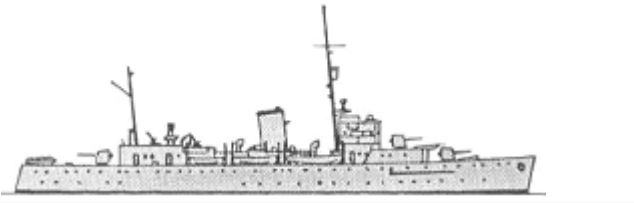
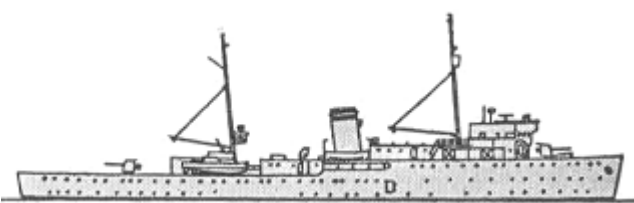
PRINCIPAL SURFACE COMBATANTS

	Tacoma	1	General Vicente Guerrero	1944		2200t, 92.6x11.4x3.9m, 3b,2vte, 5500hp, 19kts, 180p; 2x1-76/50, 2x1-20/70, 6dct, 2dcr; SF, Mk26 radars, sonar
		2	General José María Morelos	1944		
		3	California	1944		
		4	Papaloapan	1944		
FF	Guanajuato	C7	Guanajuato	1936		1950t, 80.4x11.5x3.1m, 2b,2gst, 5000hp, 20kts, 140p; 3x1-102/45, 2x1-20/70, 2x2-13.2, 2dct; 230troops, 40horses; radar
		C8	Querétaro	1936		
		C9	Potosi	1936		
	Durango	1	B1 Durango	1936		2000t, 92.4x12.2x3.1m, 2b,2gst, 6500hp, 20kts, 141p; 2x1-102/45, 2x1-57/40, 3x1-20/70, 2x2-13.2, 2dct; 490troops, 80horses; radar

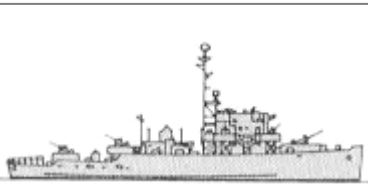
PATROL AND COASTAL COMBATANTS

PS	PCE	1	Pedro Sainz de Baranda	1944		903t, 56.2x10.1x2.9m, 2d, 2000hp, 15.1kts, 96p; 1x1-76/50, 3x2-40/60(1-3,5), 3x1-40/60(4), 4x1-20/70(1,2,5), 5x1-20/70(4), 4dct; radar, sonar
		2	David Porter	1944		
		3	Virgilio Uribe	1943		
		4	Blas Godínez	1943		
		5	Tomás Marín	1944		
	Salinas	1	Acapulco	1917		486t, 40.5x7.1x4.1m, 1b,1vte, 557hp, 7kts, 26p; 1x1-25/60, 1x1-13.2
		2	Vera Cruz	1917		
PC		G20	GC20	1935		
		G21	GC21	1935		
		G22	GC22	1935		



G20	9	G23	GC23	1936		180t, 46.6x5.0x1.6m, 2d, 3000hp, 26kts, 21p; 3x1-20/70, 2x2-12.7, 2dct	
		G25	GC25	1936			
		G26	GC26	1936			
		G27	GC27	1936			
		G28	GC28	1936			
		G29	GC29	1936			
PB	Halcon	3	1-3	Halcon, José Rafael, Nereida	1941-1942	No picture	83t, 25.9x4.3x1.5m, 2d, 800hp, 20kts, 26p
	83ft	2	1, 2	CS01, 03	1943		45t, 25.3x4.9x1.4m, 2pe, 1200hp, 20.5kts, 10p; 1x1-20/70, 2x4-178 Mousetrap AWSRL, 4dcr; radar, sonar
	Fairmile B	3	1-3	CS11-13	1942		86t, 34.8x5.6x1.5m, 2pe, 1120hp, 18kts, 28p; 1x1-40/60, 2x1-20/70, 1dct; radar, sonar

© Ivan Gogin, 2016

[home](#)[World navies yesterday](#)[1950](#)

Netherlands 01 January 1950

SUBMARINES

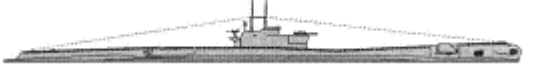
	O21	3	S801	O21	1940		990/1205t, 77.7x6.8x4.0m, 2d/em, 5000/1000hp, 19.5/9kts, 39p, 100m; 1x1-88/45(801,804), 1x1-37/69(807), 1x1-20/70(801,804), 2x2-20/65(807), (6+1x2)-533TT(801,804), 6-533TT(807)
			S804	O24	1940		
			S807	O27	1942		
SS	T batch 3 riveted	1	S814	Zwaardvis	1943		1327/1571t, 83.4x8.1x4.5m, 2d/em, 2500/1450hp, 15.2/9kts, 61p, 95m; 1x1-102/40, 1x1-20/70, 11-533TT; type 267W radar, sonars
	T batch 3 welded	2	S812	Tijgerhaai	1945		1319/1571t, 83.4x8.1x4.5m, 2d/em, 2500/1450hp, 15.2/9kts, 61p, 110m; 1x1-102/40, 1x1-20/70, 11-533TT; type 267W radar, sonars
S813			Zeehond	1944			
	T batch 2	1	S811	Dolfijn	1942		1327/1575t, 83.8x8.1x4.5m, 2d/em, 2500/1450hp, 15.2/9kts, 61p, 95m; 1x1-102/40, 1x1-20/70, 11-533TT; type 291W radar, sonars

AIRCRAFT CARRIERS

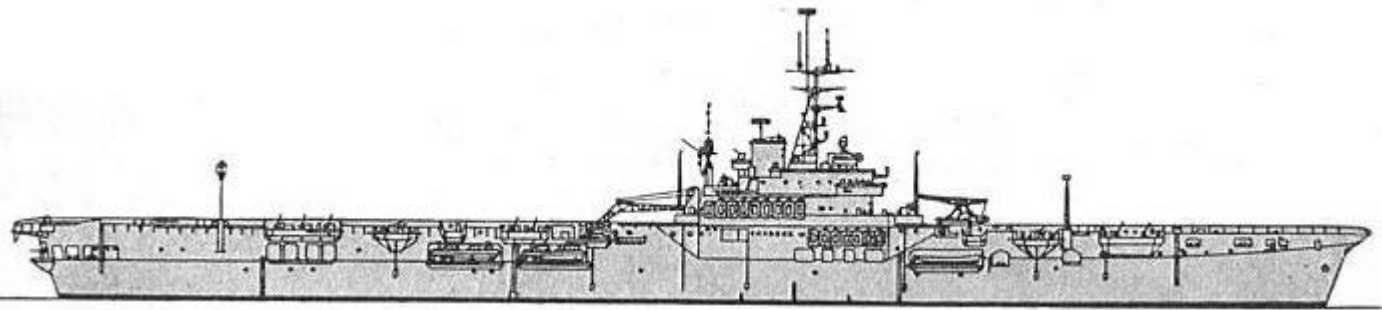



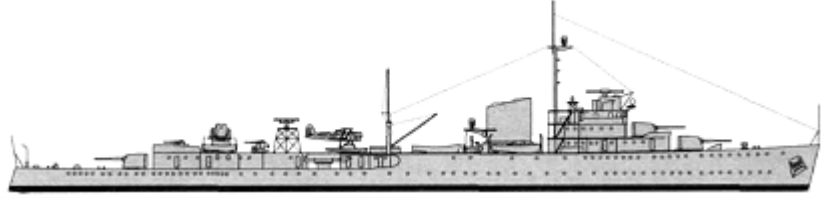

CVL	Colossus	1	R81	Karel Doorman	1945		19896t, 211.2x24.4x7.6m, 4b,2gst, 40000hp, 25kts, 1300p; 21x1-40/60, 6x4-40/39, 37aircraft (Sea Fury fighters, Firefly ASW planes); type 79B, 281B radars, type 144 sonar
-----	----------	---	-----	---------------	------	--	---

PRINCIPAL SURFACE COMBATANTS

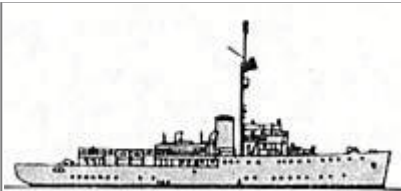



CL	Tromp	2	C803	Jacob van Heemskerck	1941		4860(803)-4817(804)t, 132.0x12.4x4.6m, 4b,2gst, 56000hp, 33.5kts, 480p; 16belt, 25deck, 25turrets, 12CT; 3x2-149/50(804), 5x2-102/45(803), 2x1-76/50, 2x1-76/40(804), 4x2-40/60(803), (2x2+4x1)-40/60(804), 4x2-20/70(803), 2x1-20/70(804), 2dcr(803); type 271(803), type281(803), 2x type285(803), type277(803), 2x type282(803), type293(803), SC-3(804), SG(804), Mk3(804) radars
			C804	Tromp	1938		
			D803	Van Galen	1942		2384t, 108.7x10.9x4.2m, 2b,2gst, 40000hp, 36kts, 218p; 3x2-120/45, 1x4-40/39, 6x1-

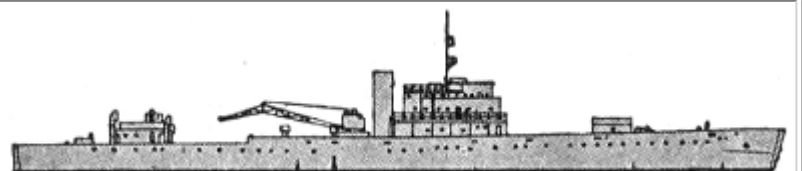

DD	N	2	D806	Tjerk Hiddes	1942		20/70(803), 4x1-20/70(806), 2x5-533TT, 4dct, 2dcr; type 271, 285, 290 radars, sonar
	Q	1	D801	Banckert	1942		2425t, 109.2x10.9x4.2m, 2b,2gst, 40000hp, 36.7kts, 225p; 4x1-120/45, 1x4-40/39, (2x2+4x1)-20/70, 2x4-533TT, 4dct, 3dcr; type 272, 282, 285, 291 radars, type 123A, 127 sonars
	S	3	D802	Evertsen	1943		2545t, 110.6x10.9x4.4m, 2b,2gst, 40000hp, 36.7kts, 225p; 4x1-120/45, 1x2-40/60(802,805), 1x4-40/39(804), 4x2-20/70, 2x4-533TT, 4dct, 2dcr; type 275, 277, 282, 291 radars, type 123A, 127 sonars
		D804	Kortenaer	1943			
		D805	Piet Hein	1943			
FF	G	1	F801	Marnix	1936		1900t, 98.5x10.1x3.8m, 3b,2gst, 34000hp, 36kts, 145p; 2x1-105/45, (2x2+2x1)-20/70, 1x24-178 Hedgehog ASWRL, 2dct; type 275, 277, 282, 291 radars, type 121 sonar
	Van Kinsbergen	1	F804	Van Kinsbergen	1939		2843t, 103.2x11.6x3.1m, 2b,2gst, 17000hp, 25.5kts, 213p; 13belt, 20deck, 20CT; 2x1-105/45, (1x2+2x1)-40/60, 2x1-20/70, 2dct; radars, sonar
	River	1	F802	Johan Maurits van Nassau	1943		1994t, 91.8x11.2x3.9m, 2b,2vte, 5500hp, 20kts, 140p; 2x1-105/45, (4x2+2x1)-20/70, 1x24-178 Hedgehog ASWRL, 8dct, 2dcr; type 272, 291 radars, sonar
	Flores	1	F803	Flores	1926		1793t, 76.4x11.5x3.6m, 4b,2vte, 2000hp, 15kts, 132p; 50slopes, 25deck,, 80shields, 50CT; 3x1-149/50, 1x2-40/60, 1x1-40/39, 4x1-20/70, 2x2-12.7
	A	1	F805	Van Speijk	1942		1470t, 77.9x10.2x2.9m, 2d, 1760hp, 14.5kts, 161p; 60belt, 35deck, 60turrets, 20CT; 2x2-120/45, 2x2-37/83, 2x2-20/65, 8dct, 80mines

PATROL AND COASTAL COMBATANTS



PSO	Jan van Brakel	1	P5	Jan van Brakel	1936		955t, 58.7x10.0x3.3m, 2b,2vte, 1600hp, 15kts, 65p; 2x1-76/50, 6x1-20/70, 2dcr, 60mines; type271 radar, sonar
PC	PC	1	P801	Queen Wilhelmina	1942		335t, 52.9x7.1x2.4m, 2d, 2880hp, 20kts, 59p; 1x1-40/60, 5x1-20/70, 2x4-178 Hedgehog ASWRL, 2dct, 2dcr; sonar
PT	BPB 70ft	1	P884	RJ2	1943		46t, 21.9x6.3x1.3m, 3pe, 3600hp, 38kts, 17p; 1x1-57/43, 1x2-20/70, 2-450TT, 2dcr; type291 radar
YP	P1	2	P1, 4		1939		23t, 18.9ppx5.6x1.2m, 1d, 165hp, 12.5kts
	P9	4	P11, 12, 15, 16		1940-1941		26t, 18.9ppx5.6x1.2m, 1d, 300hp, 14.5kts
	Fairmile B	3	RI1, 2, MV42		1940-1941		86t, 34.8x5.6x1.5m, 2pe, 1200hp, 18kts, 16p; 1x1-47/40, (1x2+1x1)-20/70, 2dct, 2dcr; type 286 radar, sonar
	HDML	16	P821-825, RP103-105, 109, 111, 112, 114-118		1943-1945		54t, 22.0x4.8x1.4m, 2d, 260-480hp, 11-13.5kts, 10p; 2x1-20/70, 2dcr; type291 radar, sonar



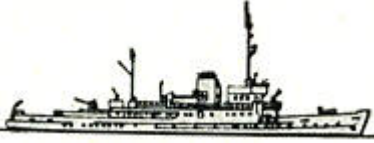
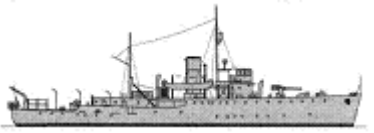

AMPHIBIOUS

LST	LST(1)	1	LST2	Pelikaan	1943		5970t, 122.4x15.4x5.6m, 2b,2gst, 7000hp, 16.2kts, 127p; 2x1-40/60, (2x2+5x1)-20/70; 1 LCM/LCS, 13tanks, 27trucks, 193troops
LCU	MFP-A	3	LT110		1941		220t, 47.0x6.5x1.5m, 3d, 390hp, 10.5kts, 21p; 1x1-75/36, 2x1-20/65; 3tanks
			LT111		1941		
			LT112		1941		
	LCT(4)	6	L9607	LT101	1944		640t, 57.1x11.8x1.4m, 2d, 920hp, 10kts, 12p; 2x1-20/70; 6tanks or 200troops
			L9608	LT102	1944		
			L9609	LT103	1944		
			L9610	LT104	1943		
			L9611	LT105	1944		
			L9612	LT106	1944		
	LCT(3)	6	L9601	LT5	1944		640t, 58.1x9.5x1.7m, 2pe, 1000hp, 11.5kts, 12p; 2x1-20/70; 5tanks
			L9602	LT6	1944		
			L9603	LT7	1944		
			L9604	LT8	1945		
			L9605	LT9	1945		
L9606			LT10	1945			
			1	Zeearend	1944		
			2	Tropenvogel	1943		

LCF	LCI(G)	5					385t, 48.9x7.2x1.8m, 8d(2), 2320hp, 15.5kts, 70p; 1x1-40/60, 3x1-20/70, 24x1 Mk7 RL; SCR-517A radar
			3	Zeemeeuw	1944		
			4	Stormvogel	1944		
		5	Ijsvogel	1944			
LC	LCM(3)	22	L9661-9665, LU111-114, A-O		1942-1944		52t, 15.2x4.3x1.4m, 2d, 220-450hp, 8.5-11kts, 3p; 1x2-12.7; 1tank
	LCA	4	L9501-9504		1942-1944		12t, 12.6x3.1x0.7m, 2pe, 130hp, 8kts, 4p; 2x1-51/11; 40troops

MINE WARFARE

ML	Willem van der Zaan	1	ML2	Willem van der Zaan	1939		1407t, 75.2x11.2x3.3m, 2b,2vte, 2200hp, 15.5kts, 92p; 2x1-120/50, 1x4-40/39, 2x2-12.7, 2dcr, 90mines, 1seaplane(C.XIW); sonar
MSO	Jan van Amstel	4	M801	Abraham Crijnsen	1937		585t, 56.8x7.8x2.0m, 2b,2vte, 1600hp, 15kts, 45p; 1x1-75/55, 4x1-20/70, 40mines, mechanical sweeps
			M802	Abraham van der Hulst	1940		
			M803	Jan van Gelder	1937		
			M804	Pieter Florisz	1937		
	Bathurst	6	MV21	Ambon	1942		790t, 56.7x9.5x3.0m, 2b,2vte, 1550-2000hp, 15-16kts, 90p; 1x1-102/40, 1x1-40/60, 4x1-20/70, 4dct, 2dcr, sweeps; radar, sonar
			MV22	Banda	1941		
			MV23	Batjan	1941		
			MV24	Boeroe	1941		
			MV25	Ceram	1941		
			MV27	Ternate	1942		
MMS1	8	M861	Ameland	1942		295t, 36.4x7.1x2.7m, 1d, 480hp, 10.5kts, 20p; 1x1-20/70, 1x2-12.7; acoustic, magnetic, mechanical sweeps	
		M862	Beveland	1943			
		M863	Marken	1941			
		M864	Putten	1943			
		M865	Rozenburg	1943			
		M866	Terschelling	1943			
		M867	Texel	1942			
		M868	Vlieland	1942			
	MMS1001	5	M821	Duiveland	1944		430t, 42.7x8.5x3.2m, 1d, 500hp, 10kts, 21p; 2x1-20/70, acoustic, magnetic, mechanical sweeps
			M822	Overflakkee	1944		
			M823	Tholen	1943		
			M824	Voorne	1943		
			M825	Ijsselmonde	1943		
			M831	Borndiep	1943		
			M832	Deurloo	1943		

BYMS	10	M833	Hollandsch Diep	1943		250t, 41.5x7.5x2.4m, 2d, 800hp, 15kts, 60p; 1x1-76/50, 2x1-20/70, mechanical, acoustic, magnetic sweeps	
		M834	Marsdiep	1943			
		M835	Oosterschelde	1943			
		M836	Texelstroom	1943			
		M837	Vlietstroom	1943			
		M838	Volkerak	1943			
		M839	Westerschelde	1943			
		M840	Zuiderdiep	1943			
DEFG	6	HMV20	Djombang	1941		175t, 34.7x5.7x1.9m, 1d, 360hp, 12.5kts, 14p; mechanical sweeps	
			Djampea	1941			
		HMV21	Enggano	1941			
			Flores	1943			
			Fakfak	1943			
			Garoet	1943			
MSI	R218	9	M869	Goeree	1944		148t, 39.4x5.7x1.5m, 2d, 2500hp, 21kts, 40p; 1x1-37/83, 3x2-20/65, 2dcr, sweeps
			M870	Malzwin	1944		
			M872	Schiermonnikoog	1944		
			M873	Schouwen	1944		
			M874	Schulpengat	1944		
			M875	Stortemelk	1944		
			M876	Urk	1944		
			M877	Vlieter	1945		
			M878	Walcheren	1943		
R401	1	M871	Roompot	1946		150t, 39.4x5.7x1.5m, 2d, 2800hp, 25kts, 37p; 1x1-37/69, 3x2-20/65, 2dcr, sweeps	



[home](#)[World navies yesterday](#)[1950](#)

New Zealand 01 January 1950

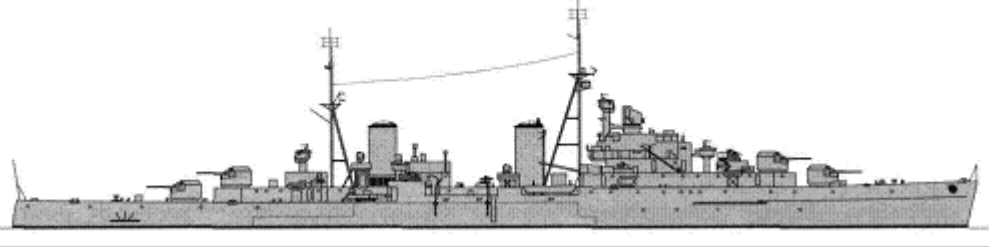
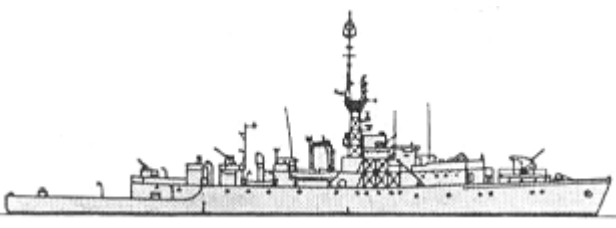
PRINCIPAL SURFACE COMBATANTS

CL	Black Prince	2	63	Bellona	1943		7410t, 156.1x15.4x5.5m, 4b,4gst, 62000hp, 32kts, 530p; 76belt, 51deck, 13turrets; 4x2-133/50, 8x1-40/60(81), 3x4-40/39, (6x2+8x1)-20/70(63), (8x2+8x1)-20/70(81), 2x3-533TT; type 272, 281, 3x 282, 284, 2x 285 radars
			81	Black Prince	1943		
FF	Loch	6	K421	Taupo	1944		2260t, 93.6x11.8x3.8m, 2b,2vte, 5500hp, 19.5kts, 114p; 1x1-102/45, 2x1-40/60(422), 1x4-40/39, (4x2+2x1)-20/70(421,424,426,517,625), 4x1-20/70(422), 2x3-305 Squid ASWRL, 2dct, 1dcr; type 277, 291 radars, sonars
			K422	Hawea	1944		
			K424	Pukaki	1944		
			K426	Kaniere	1945		
			K517	Tutira	1944		
			K625	Rotoiti	1944		

PATROL AND COASTAL COMBATANTS

PB	Fairmile B	1	ML411	Kahu	1943		86t, 34.8x5.6x1.5m, 2pe, 1200hp, 18kts, 16p; 1x1-47/40, 2dcr; type 291 radar, sonar
	HDML	14	ML1183		1943		54t, 22.0x4.8x1.4m, 2d, 300hp, 11.5kts, 10p; 2x1-20/70, 2dcr; type 291 radar
			ML1184		1943		
			ML1185	Bombardier	1943		
			ML1187		1943		
			ML1188		1943		
			ML1190		1943		
			ML1191		1943		
			ML1192		1943		
			ML1193		1943		
			ML1194	Ngapona	1943		
			ML1348		1944		
			ML1349		1944		

		ML1350		1944
		ML1351		1944

MINE WARFARE

MSO	Isle	4	T155	Inchkeith	1941		770t, 50.0x8.4x3.4m, 1b,1vte, 850hp, 12.2kts, 40p; 1x1-76/40, 3x1-20/70, 2dct, 2dcr, sweeps
			T160	Sanda	1941		
			T174	Killegray	1941		
			T175	Scarba	1941		
	Kiwi	2	T102	Kiwi	1941		825t, 47.6x9.2x3.5m, 1b,1vte, 1000hp, 14kts, 35p; 1x1-102/44, 1x1-40/39, 4dct, 2dcr, sweeps
			T234	Tui	1941		
	Castle	3	T340	Hautapu	1944	No picture	625t, 38.1x7.2x4.3m, 1b,1vte, 10kts, 42p; 1x1-76/40, 1x1-20/70, 1dct, sweeps
			T399	Hinau	1942		
			T402	Rimu	1942		

© Ivan Gogin, 2016

[home](#)

[World navies yesterday](#)

[1950](#)

Nicaragua 01 January 1950

PATROL AND COASTAL COMBATANTS



PB	GC2	4	GC2-5	-	1947	No picture	27.5m
----	-----	---	-------	---	------	------------	-------

© Ivan Gogin, 2016

[home](#)[World navies yesterday](#)[1950](#)

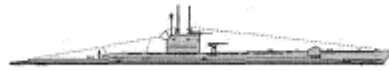

Norway 01 January 1950

SUBMARINES



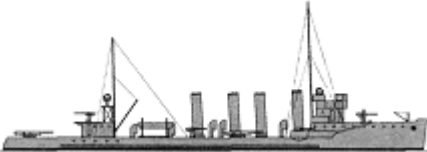
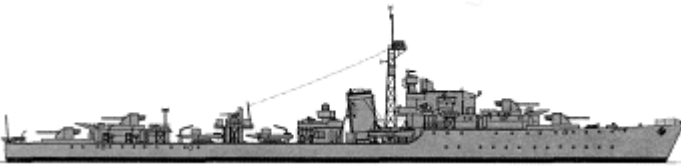
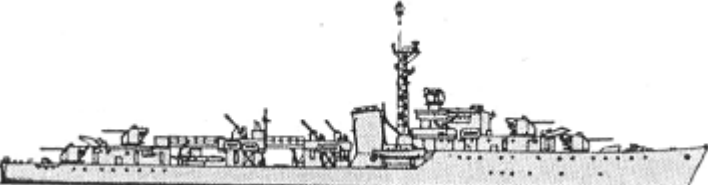

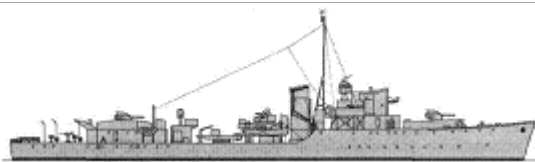
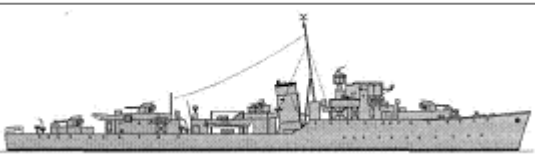
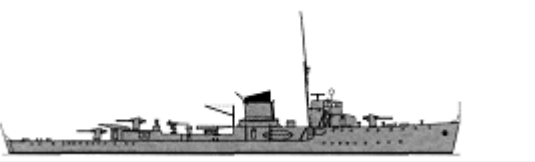
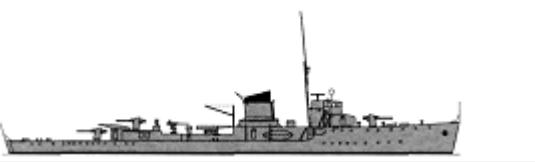
SS	U	1	P81	Ula	1943		630/732t, 60.0x4.9x4.6m, 2dg,2em, 615/825hp, 11.2/10kts, 33p, 60m; 1x1-76/45, 4-533TT; type 291W radar, sonars
	V	4	P85	Utsira	1944		662/740t, 62.3x4.9x4.7m, 2dg,2em, 615/825hp, 11.2/10kts, 33p, 90m; 1x1-76/45, 2x1-20/70, 4-533TT; type 267QW radar, sonars
			P68	Utstein	1943		
			P69	Utvær	1943		
			P29	Uthaug	1944		
	VIIC	2	1	Kya	1944		769/1070t, 67.1x6.2x4.7m, 2d/em, 3200/750hp, 17.7/7.6kts, 56p, 100m; 1x1-37/69, 2x2-20/65, 5-533TT; FuMO65 radar, sonar
2			Kinn	1944			
VIIC/41	1	1	Kaura	1943		769/1070t, 67.2x6.2x4.8m, 2d/em, 3200/750hp, 17.7/7.6kts, 56p, 120m; 1x1-37/69, 2x2-20/65, 5-533TT; FuMO65 radar, sonar	
XXIII	1	1	Knerter	1945		234/258t, 34.7x3.0x3.7m, 1d/em, 630/580hp, 9.7/12.5kts, 14p, 80m; 2-533TT; sonar	

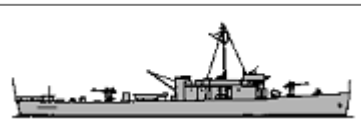

PRINCIPAL SURFACE COMBATANTS

DD	Draug	1	1	Troll	1912		578t, 69.2x7.3x2.9m, 4b,2vte, 7500hp, 27kts, 76p; 6x1-76/40, 1x1-12.7, 3x1-450TT
	S	1	1	Stord	1943		2530t, 110.6x10.9x4.3m, 2b,2gst, 40000hp, 36.7kts, 225p; 4x1-120/45, 1x2-40/60, 4x2-20/70, 2x4-533TT, 4dct, 2dcr; type 275, 277, 282, 291 radars, type 123, 127 sonars
	Cr	4	1	Oslo	1947		2535t, 110.6x10.9x4.4m, 2b,2gst, 40000hp, 36.7kts, 186p; 4x1-114/45, 1x2-40/60, (2x2+2x1)-20/70, 1x4-533TT, 2dct, 2dcr; type 275, 277, 282, 291 radars, type 123, 127 sonars
			2	Bergen	1946		
3			Trondheim	1945			
	4	4	Stavanger	1946			





FF	Hunt 3	1	1	Narvik	1942		1590t, 85.3x9.6x3.7m, 2b,2gst, 19000hp, 27kts, 168p; 2x2-102/45, (1x4+1x1)-40/39, 3x1-20/70, 1x2-533TT, 4dct, 2dcr; type 272, 285, 291 radars, type 123A, 127 sonar
	Hunt 2	1	1	Arendal	1941		1625t, 85.3x9.6x3.8m, 2b,2gst, 19000hp, 27kts, 168p; 3x2-102/45, 1x4-40/39, 4x1-20/70, 2dct, 3dcr; type 271, 285, 291 radars, type 123A, 127 sonars
FS	Sleipner	2	L01	Sleipner	1937		708t, 74.3x7.8x2.1m, 3b,2gst, 12500hp, 30kts, 75p; 1x1-105/45(02), 2x1-102/45(01), 1x1-40/60(01), 1x1-37/83(02), 2x1-20/70(01), 2x1-20/65(02)), 1x2-533TT(01), 4dct(01), 2dcr(01), 24mines(01)
			L02	Gyller	1939		
	Odin	3	L03	Odin	1939		719t, 76.0x7.8x2.1m, 3b,2gst, 12500hp, 30kts, 75p; 1x1-105/45, 1x1-37/83, 4x1-20/65(03), 2x1-20/65(04,05)
			L04	Tor	1940		
			L05	Balder	1940		
	Flower	3	K01	Andenes	1941		1170t, 62.5x10.1x4.5m, 2b,1vte, 2750hp, 16.5kts, 109p; 1x1-102/45, 1x1-40/39, 2x1-20/70, 1x24-178 Hedgehog ASWRL, 4dct, 2dcr; type 286, 290 radars, sonar
			K197	Sørøy	1941		
K193			Nordkyn	1942			

PATROL AND COASTAL COMBATANTS

PC	PC 173ft	1	1	Kong Haakon VII	1942		330t, 52.9x7.1x2.4m, 2d, 2880hp, 21kts, 59p; 1x1-40/60, 5x1-20/70, 4dct, 2dcr; radar, sonar
PT	Fairmile D	9	MTB704	Ørn	1943		118t, 35.1x6.5x1.5m, 4pe, 4800hp, 29kts, 30p; 1x1-57/43, (1x2+2x1)-20/70, 4-450TT, 2dc; SO radar
			MTB709	Lom	1944		
			MTB711	Falk	1944		
			MTB715	Teist	1943		
			MTB716	Ravn	1944		
			MTB717	Stegg	1944		
			MTB719	Skarv	1944		
			MTB722	Jo	1944		
			MTB723	Kjeld	1944		
	S38	4	1	Kvikk	1943		115t, 34.9x5.3x1.7m, 3d, 7500(1)-6000(2-4)hp, 41(1)-39(2-4)kts, 31p; 12CT(4); 1x1-40/60, (1x2+1x1)-20/65, 2-533TT, 2dcr, 6mines
2			Lyn	1941			
3			Storm	1942			
4			Tross	1942			
S139	2	1	Rapp	1944		122t, 34.9x5.3x1.7m, 3d, 7500hp, 41kts, 31p; 12CT; 1x1-40/60, (1x2+1x1)-20/65, 2-533TT, 2dcr; 6mines	
		2	Snar	1944			
S7	1	1	Blink	1935		86t, 32.4x5.1x1.4m, 3d, 3960hp, 36.5kts, 23p; 2x1-20/65, 2-533TT	

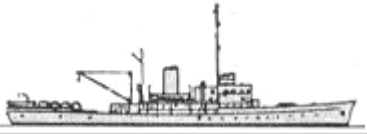
						
S10	2	1	Brand	1935		92t, 32.4x5.1x1.4m, 3d, 3960hp, 35kts, 23p; 2x1-20/65, 2-533TT, 6dc
		2	Kjekk	1935		
PB SC 110ft	3	1	Hessa	1942		136t, 33.8x5.5x2.0m, 2d, 2400hp, 21kts, 27p; 1x1-40/60, 4x1-20/70, 2x4-178 Mousetrap ASWRL, 2dct, 2dcr; radar, QC sonar
		2	Hitra	1943		
		3	Vigra	1943		

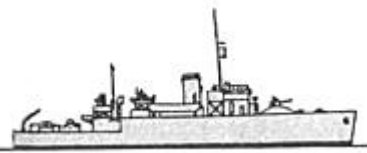
MINE WARFARE

ML	Otra	2	1	Otra	1939		370t, 52.1x7.1x1.8m, 1b,2vte, 900hp, 13.5kts, 25p; 1x1-40/60, 2x1-20/70, 2x1-12.7, sweeps, mines
			2	Rauma	1940		
	LCT(4)	2	1	Vargsund	1945		640t, 57.1x11.8x1.4m, 2d, 920hp, 10kts, 12p; 2x1-20/70, 80mines
			2	Reinøsund	1945		
MSO	Bangor	2	1	Glomma	1940		690t, 49.4x8.5x2.8m, 2d, 2000hp, 16.5kts, 60p; 1x1-76/45, 3x1-20/70, 4dct, 2dcr, sweeps; radar, sonar
			2	Tana	1941		
MSC	MMS1001	2	1	Orkla	1944		430t, 42.7x8.5x3.2m, 1d, 500hp, 10kts, 21p; 2x1-20/70, sweeps
			2	Vefsna	1944		
	YMS	7	1	Vinstra	1943		320t, 41.5x7.5x2.4m, 2d, 800hp, 14kts, 60p; 1x1-76/50, 2x1-20/70, 2dct, 2dcr, sweeps; radar
			2	Gaula	1943		
			3	Driva	1943		
			4	Alta	1943		
			5	Vorma	1943		
6	Begna	1943					
7	Rana	1943					

COAST GUARD

PC	Nordkapp	2	1	Nordkapp	1937		275t, 39.8x6.6x2.3m, 2dg,1em, 830hp, 13.7kts, 22p; 1x1-76/40, 1x1-40/60, 2x1-20/70, 2dcr
			2	Senja	1937		

[home](#)

[World navies yesterday](#)



[1950](#)

Pakistan 01 January 1950

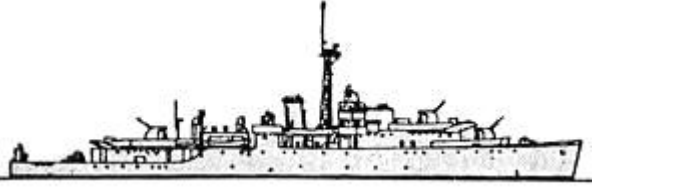
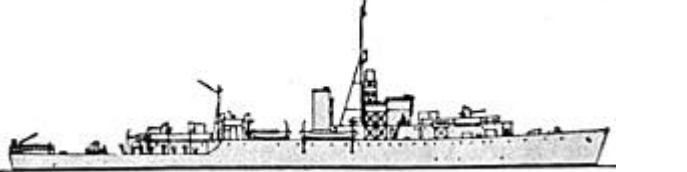
PRINCIPAL SURFACE COMBATANTS

DD	O	2	D49	Tippu Sultan	1941		2430t, 105.2x10.7x4.3m, 2b,2gst, 40000hp, 37kts, 212p; 4x1-120/45, 1x4-40/39, (2x2+2x1)-20/70, 2x4-533TT, 4dct, 2dcr; type 272, 282, 285, 291 radars, type 123A, 127 sonars
			D129	Tariq	1941		
FF	Bittern mod.	2	U40	Jhelum	1943		1758t, 89.2x11.4x3.3m, 2b,2gst, 3600hp, 19kts, 195p; 3x2-102/45, (2x2+2x1)-20/70, 4dct, 2dcr; type 272, 285, 291 radars, type 123A, 127 sonars
			U52	Sind	1943		
River	2	K265	Zulfiqar	1943		2180t, 91.8x11.2x3.9m, 2b,2vte, 5500hp, 20kts, 140p; 2x1-102/40, (4x2+2x1)-20/70, 1x24-178 Hedgehog ASWRL, 8dct, 2dcr; type 271, 291 radars, sonars	
		K392	Shamsher	1944			

PATROL AND COASTAL COMBATANTS

PS	Basset	2	T12	Lahore	1945		775t, 50.0x8.4x3.4m, 1b,1vte, 950hp, 13kts, 48p; 1x1-76/40, 3x1-20/70, 2dct, 2dcr
			T249	Bahawalpur	1942		
PB	HDML	4	SDML1261-1263, 1266		1944-1945		54t, 22.0x4.8x1.4m, 2d, 260hp, 11kts, 10p; 1x1-47/40, 1x1-20/70, 2dcr

MINE WARFARE

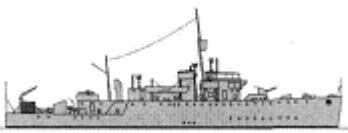
MSO	Bangor turbine	2	J155	Chittagong	1942		780t, 53.0x8.7x3.0m, 2b,2gst, 2000hp, 16.5kts, 87p; 1x1-76/40, 3x1-20/70, 4dct, 2dcr, minesweeping gear; radar, sonar
			J182	Baluchistan	1942		
			J55	Peshawar	1945		

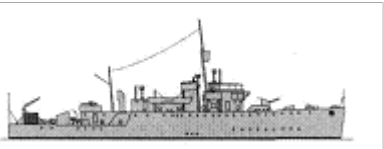
	Bangor VTE	2	J245	Dacca	1943		875t, 54.9x8.7x3.1m, 2b,2vte, 2400hp, 16.5kts, 87p; 1x1-76/40, 3x1-20/70, 4dct, 2dcr, minesweeping gear; radar, sonar
--	------------	---	------	-------	------	---	---

© Ivan Gogin, 2016

[home](#)[World navies yesterday](#)[1950](#)

Paraguay 01 January 1950

PATROL AND COASTAL COMBATANTS

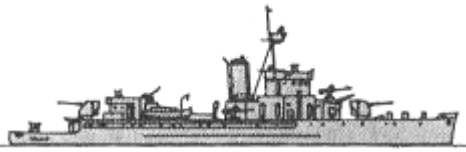
PR	Paraguay	2	C1	Paraguay	1931		835t, 71.2x10.7x2.9m, 2b,2gst, 3800hp, 17kts, 86p; 12belt, 8deck, 10turrets, 19CT; 2x2-120/50, 3x1-76/40, 2x1-40/39, 6mines
			C2	Humaitá	1931		
APR	-	2	P01	Capitán Cabral	1907		206t; 1x1-76/40
			P02	Tacuari	1910		150t; 2x1-76/50, 2x1-76/40
PB	USCG 40ft	6	P1-6		1944	No picture	16t, 13.9x4.1x1.1m, 2pe, 190hp, 20kts, 10p; 2x1-20/70

© Ivan Gogin, 2016



[home](#)[World navies yesterday](#)[1950](#)

Peru 01 January 1950

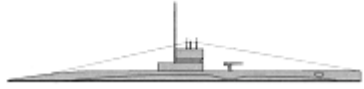
SUBMARINES

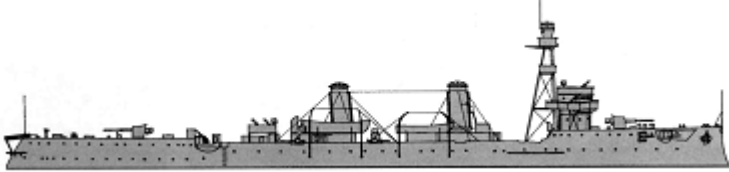
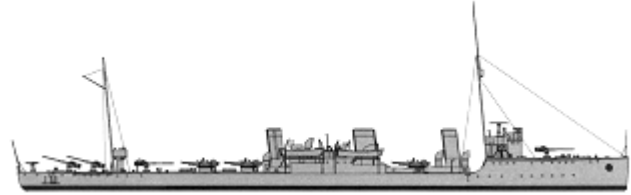

SS	R1	4	1	R1	1926		576/755t, 56.8x5.3x4.6m, 2d/em, 800/1000hp, 14.5/9.5kts, 30p, 60m; 1x1-76/50, 4-533TT
			2	R2	1926		
			3	R3	1928		
			4	R4	1928		

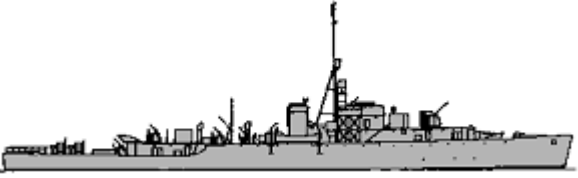
PRINCIPAL SURFACE COMBATANTS

CL	Almirante Grau	2	1	Almirante Grau	1907		4877t, 115.8x12.3x4.3m, 8b,2vte, 14000hp, 23.5kts, 320p; 38belt, 38deck, 76shields, 76CT; 2x1-152/50, 6x1-76/40, 7x1-12.7, 1dct, 2dcr
			2	Coronel Bolognesi	1907		
DD	Leytenant Ilyin	1	1	Almirante Villar	1917		1620t, 98.0x9.3x3.9m, 4b,2gst, 31500hp, 34kts, 142p; 4x1-102/60, 1x1-40/39, 3x1-20/65, 3x3-450TT, 80mines
FF	Tacoma	1	F1	Teniente Gálvez	1944		2238t, 92.6x11.4x3.9m, 3b,2vte, 5500hp, 20kts, 190p; 3x1-76/50, 2x2-40/60, 9x1-20/70, 1x24-178 Hedgehog ASWRL, 8dct, 2dcr; SF, Mk26 radars, sonar
	Canadian River	2	F3	Teniente Ferré	1944		2180t, 91.8x11.2x3.9m, 2b,2vte, 20kts, 140p; 1x2-102/45, 1x1-76/40(3), 4x2-20/70(3), (4x2+2x1)-20/70(4), 1x24-178 Hedgehog ASWRL, 8dct, 2dcr; type 268, 272, 275, 291 radars, sonars
			F4	Teniente Palacios	1944		

PATROL AND COASTAL COMBATANTS

	Iquitos	1	1	Iquitos	1896	No picture	50t, 23.4x3.7x1.2m, 7.5kts; 4x1-37/20, 2x1-20/60
	América	1	1	América	1904	No picture	240t, 40.5x5.9x1.4m, 2b,2vte, 350hp, 14kts, 26p; 2x1-65/50, 3x1-47/40, 2x1-20/60



PR	Napo	1	1	Napo	1920	No picture	98t, 30.9x5.5x0.9m, 1b,1vte, 250hp, 12kts, 22p; 4x1-47/40, 2x1-20/60
	Amazonas	2	1	Amazonas	1935		250t, 46.7x6.7x1.4m, 2d, 750hp, 15.5kts, 35p; 4x1-76/50, 2x1-47/40
2			Loreto	1935			
PB	CG 83'	6	1-6	CS1-6	1942-1943		45t, 25.3x4.9x1.4m, 2pe, 1200hp, 20.5kts, 10p; 1x1-20/70, 4dcr

© Ivan Gogin, 2016

[home](#)[World navies yesterday](#)[1950](#)

Philippines 01 January 1950

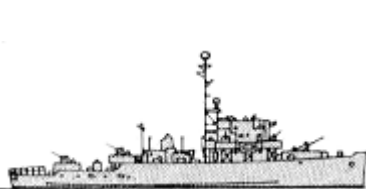
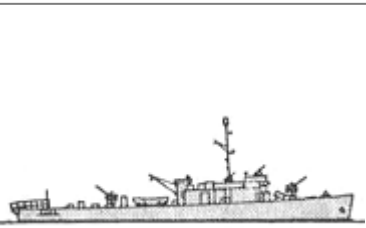
PATROL AND COASTAL COMBATANTS

PS	Admiralty	1	M33	Samar	1944		903t, 56.2x10.1x3.0m, 2d, 2000hp, 15kts, 95p; 1x1-76/50, 2x2-40/60, 4x1-20/70; SO radar
	PCE	5	E28	Cebu	1944		903t, 56.2x10.1x2.9m, 2d, 2000hp, 15.1kts, 85p; 1x1-76/50, 3x2-40/60, 4x1-20/70, 1x24-178 Hedgehog ASWRL, 4dct, 2dcr; SO radar, sonar
			E29	Negros Occidental	1945		
			E30	Leyte	1945		
			E31	Pangasian	1944		
E32	Iloilo	1945					
PC	PC 173ft	7	C21	Camarines Sur	1942		463t, 52.9x7.1x3.3m, 2d, 2880hp, 19kts, 65p; 1x1-76/50, 1x1-40/60, 5x1-20/70, 2x4-178 Mousetrap ASWRL, 2dct, 2dcr; SF radar, QHa sonar
			C22	Bohol	1943		
			C23	Zamboanga del Sur	1943		
			C24	Batangas	1943		
			C25	Nueva Esija	1943		
			C26	Negros Oriental	1944		
			C27	Capiz	1944		
	PCS	2	P11	Tarlac	1944		278t, 41.5x7.5x2.4m, 2d, 800hp, 14kts, 57p; 1x1-76/50, 1x1-40/60, 4x1-20/70; radar
			P12	Laguna	1944		
	SC	8	P14	Cagayan	1942		136t, 33.8x5.5x2.0m, 2d, 1000hp, 16kts, 27p; 1x1-40/60, 3x1-20/70, 2x4-178 Mousetrap ASWRL, 2dct, 2dcr; SF radar, QC sonar
			P15	Mountain Province	1943		
			P16	Ilocus Sur	1942		
			P17	Surigao	1942		
P18			Isabella	1942			
P19			Cavite	1942			
P20	Ilocus Norte	1943					
PY54	Alert	1943					

AMPHIBIOUS

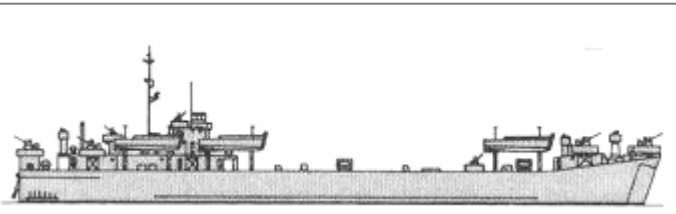

LST	LST1	5	T36	Cotabato	1943		<p>4080t, 100.0x15.2x4.3m, 2d, 1800hp, 12.1kts, 125p; (2x2+4x1)-40/60, 12x1-20/70; 4 LCVP, 20tanks, 163troops; radar</p>
			T37	Pampanga	1944		
			T38	Bulacan	1944		
			T39	Albay	1944		
			T40	Misamis Oriental	1944		

© Ivan Gogin, 2016

[home](#)[World navies yesterday](#)[1950](#)

Poland 01 January 1950

SUBMARINES

SS	Wilk	3	1	Wilk	1931		980/1248t, 78.5x5.9x4.2m, 2d/em, 1800/1200hp, 14.5/9.5kts, 54p, 80m; 1x1-100/40, 1x2-13.2, (4+1x2)-550TT, 38mines
			2	Ryś	1931		
			3	Żbik	1932		
	Orzeł	1	1	Sęp	1939		1473/1650t, 84.0x6.7x4.2m, 2d/em, 4740/1100hp, 19.4/9kts, 60p, 80m; 1x1-100/51, 12-533TT

PRINCIPAL SURFACE COMBATANTS

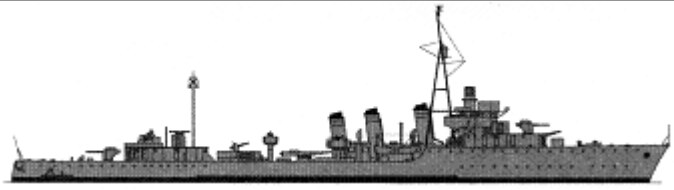
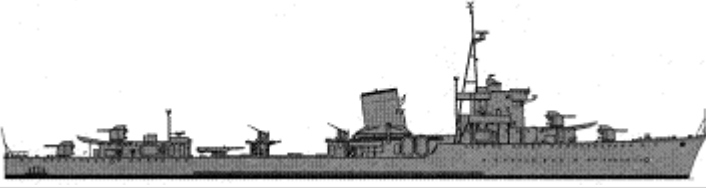

DD	Burza	1	52	Burza	1932		2430t, 107.2x10.2x3.8m, 3b,2gst, 33000hp, 30kts, 155p; 2x1-130/40, 1x1-76/45, 1x4-40/39, 6x1-20/70, 1x3-550TT, 1x24-178 Hedgehog ASWRL, 4dct, 2dcr, 60mines; type 271, 292 radars
	Grom	1	51	Błyskawica	1937		
							2440t, 114.0x11.3x3.5m, 4b,2gst, 54000hp, 39kts, 200p; 4x2-102/45, 2x2-40/60, 4x1-20/70, 1x4-533TT, 4dct, 2dcr, 44mines; type 284, 291, 293 radars

PATROL AND COASTAL COMBATANTS

PT	D-3	2	Tp1, 2		1943		35t, 22.4x4.0x1.8m, 3pe, 3600hp, 48kts, 12p; 2x2-12.7, 2-533TT, 1dcr	
PB	pr. 194	2	1	Bitny	1944		74t, 24.8x4.2x1.6m, 2pe/1pe(2), 2400/68hp, 21kts, 24p; 10belt, 12deck, 12CT; 1x1-45/69, 1x1-37/73, 2x2-12.7, 2dcr	
			2	Błyskawiczny	1944			
	OD-200	11	6	1	Bezwzględny	1944		
				2	Bystry	1944		
				3	Dziarski	1944		
				4	Dzielny	1944		
			5	Karny	1944			
			6	Niedościgły	1944		47t, 23.4x4.0x1.8m, 2pe/2pe(2), 2400/170hp, 24kts, 21p; 1x1-37/73, 2x2-12.7, 2dcr	

					
		7	Nieuchwytny	1944	
		8	Odważny	1944	
		9	Smiały	1944	
		10	Sprawny	1944	
		11	Szybki	1944	

MINE WARFARE

MSC	YMS	3	DF	Delfin	1943		320t, 41.5x7.5x2.4m, 2d, 800hp, 14kts, 60p; 1x1-76/50, 2x1-20/70, 2dct, 2dcr, sweeps; SO radar
			FK	Foka	1944		
			MS	Mors	1943		
MSI	Jaskółka	3	CJ	Czajka	1936		203t, 45.0x5.5x1.6m, 2d, 1040hp, 17.5kts, 30p; (1x4+2x2)-20/65, sweeps
			MW	Mewa	1935		
			RB	Rybitwa	1935		
	pr. 253LP	9	CP	Czapla	1945		143t, 38.0x5.7x1.4m, 3d, 480hp, 12.5kts, 21p; 2x1-45/69, 2x2-12.7, 2dcr, 12mines, sweeps; Tamir-10 sonar
			KD	Kondor	1945		
			KG	Krogulec	1945		
			JK	Jaskółka	1945		
			AB	Albatros	1945		
			OK	Orlik	1945		
			JT	Jastrząb	1945		
	KM	Kormoran	1945				
	KN	Kania	1945				

BOARD GUARD



PB	Batory	1	1	7 Listopada	1932	No picture	28t, 21.2x3.6x1.1m, 3pe, 1100/175hp, 24.3kts, 10p
	Wał Pomorski	2	DP51	Wał Pomorski	1943	No picture	210t
			DP52	Lenino	1943		
	Tkacz	1	DP86	Tkacz	1943	No picture	100t
	Baca	2	1	Baca	1949	No picture	45t, 17.8x5.0x1.6m, 1d, 100hp, 9kts, 6p; 1x1-12.7
			2	Juhas	1949		

© Ivan Gogin, 2016



[home](#)[World navies yesterday](#)[1950](#)

Portugal 01 January 1950

SUBMARINES



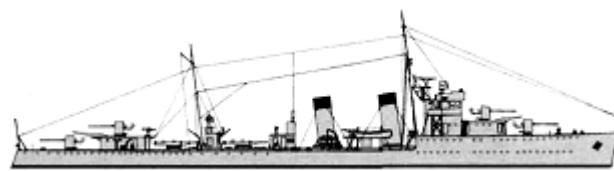
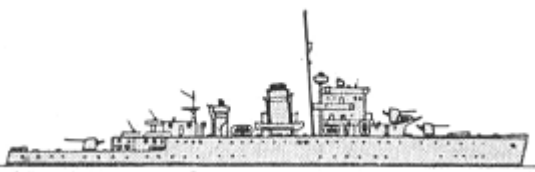

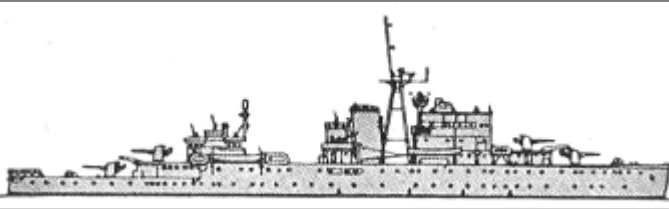
SS	Delfim	3	D	Delfim	1935		800/1092t, 69.2x6.5x3.9m, 2d/em, 2300/1000hp, 16.5/9.2kts, 38p, 60m; 1x1-102/40, 2x1-12.7, 6-533TT
			E	Espadarte	1935		
			G	Golfinho	1935		
S		3	1	Narval	1945		814/990t, 66.1x7.2x4.3m, 2d/em, 1900/1300hp, 14.7/9kts, 48p, 110m; 1x1-102/40, 1x1-20/70, 6-533TT; type 267W radar, sonar
			2	Náutico	1945		
			3	Neptuno	1944		

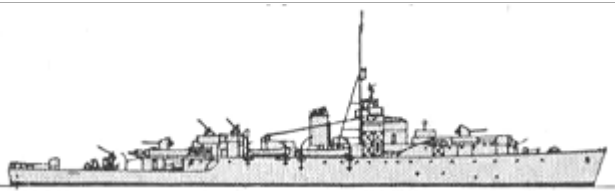
PRINCIPAL SURFACE COMBATANTS

DD	Vouga	5	D	Dão	1935		1563t, 98.5x9.5x3.4m, 3b,2gst, 33000hp, 36kts, 184p; 4x1-120/50, 7x1-20/70, 1x4-533TT, 4dct, 2dcr, 20mines; radar
			DR	Douro	1936		
			L	Lima	1933		
			V	Vouga	1933		
			T	Tejo	1935		
	Gonçalo Velho	2	1	Gonçalo Velho	1933		1414t, 81.7x10.8x3.4m, 2b,2gst, 2000hp, 16.5kts, 142p; 3x1-120/50, 5x1-20/70, 4dct, 2dcr
			2	Gonçaves Zarco	1933		
FF	Pedro Nunes	2	1	Pedro Nunes	1935		1220t, 71.4x10.0x2.8m, 2d, 2400hp, 16.5kts, 138p; 2x1-120/50, 4x1-20/70, 4dct, 2dcr
			2	João de Lisboa	1937		
	Afonso de Albuquerque	2	1	Afonso de Albuquerque	1935		2480t, 103.2x13.5x3.8m, 2b,2gst, 8000hp, 21kts, 184p; 4x1-120/50, 2x1-76/50, 8x1-20/70, 4dct, 2dcr, 40mines; radar
			2	Bartolomeu Dias	1935		
		1	Diogo Gomes	1944		2180t, 91.8x11.2x3.8m, 2b,2vte, 5500hp, 20kts, 140p; 2x1-102/40, 6x1-40/60, 1x24-178	

River	2	2	Nuno Tristão	1943		Hedgehog ASWRL, 8dct, 2dcr; type 277, 291 radars, sonars
-------	---	---	--------------	------	---	--

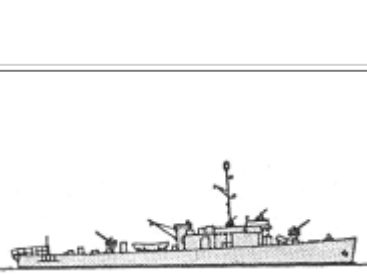
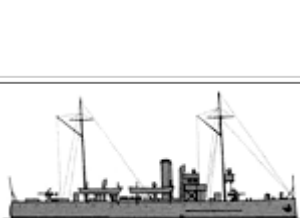
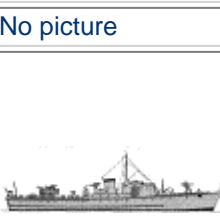
PATROL AND COASTAL COMBATANTS

PC	Faro	1	Faro	1928		300t, 39.8x6.7x3.2m, 1b,1vte, 650hp, 13kts, 52p; 2x1-47/40
		2	Lagos	1930		
	Azevia	A	Azevia	1941		270t, 42.6x6.5x2.1m, 2d, 2400hp, 17kts, 37p; 2x1-20/70, 2dct
		B	Bicuda	1941		
		C	Corvina	1941		
		D	Dourada	1942		
		E	Espadilha	1942		
	PC 173ft	1	Flores	1945		463t, 52.9x7.1x3.3m, 2d, 2880hp, 19kts, 65p; 1x1-76/50, 1x1-40/60, 2x1-20/70, 2x4-178 Mousetrap ASWRL, 2dct, 2dcr; radar, sonar
		2	Madeira	1945		
		3	Santiago	1944		
		4	Sal	1945		
		5	São Tomé	1944		
		6	São Vicente	1945		
	Zaire	Z	Zaire	1925		492t, 45.0x8.3x2.1m, 2b,2vte, 700hp, 13kts, 67p; 2x1-76/40, 2x1-20/70, 2dct
D		Diu	1929			
PR	Téte	1	Téte	1918	No picture	130t, 23.4x6.1x0.7m, 1b,1vte(sw), 70hp, 8kts, 20p; 2x1-47/43
PB	Fairmile B	L1	Altair	1943		86t, 34.8x5.6x1.5m, 2pe, 1200hp, 18kts, 16p; 1x1-47/40, (1x2+1x1)-20/70, 2dct, 2dcr; type 286 radar, sonar
		L2	Belatrix	1943		
		L3	Canopus	1943		
		L4	Deneb	1944		
		L5	Espiga	1944		
		L6	Fomalhaut	1944		
	HDML		2	ML1106	1943	
		ML1108	1944			

MINE WARFARE

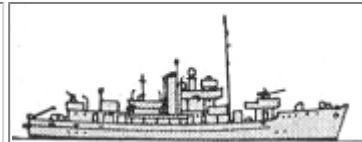
Tree	1	F	Faial	1940		770t, 50.0x8.4x3.4m, 1b,1vte, 850hp, 12.2kts, 40p; 1x1-76/40, 2x1-20/70, 2dct, 2dcr, sweeps
------	---	---	-------	------	--	---

MSO	Dance	1	C	Salvador Correia	1940		770t, 50.0x8.4x3.4m, 1b,1vte, 850hp, 12.2kts, 40p; 1x1-102/45, 3x1-20/70, 2dct, 2dcr, sweeps
	Isle	4	M	São Miguel	1942		770t, 50.0x8.4x3.4m, 1b,1vte, 850hp, 12.2kts, 40p; 1x1-76/40, 3x1-20/70, 4dct, 2dcr, sweeps
			T	Terceira	1942		
			MR	Santa Maria	1942		
			S	Baldaque da Silva	1942		

© Ivan Gogin, 2015



[home](#)[World navies yesterday](#)[1950](#)

Romania 01 January 1950

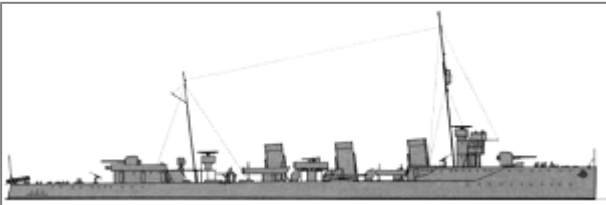

SUBMARINES

SS	Delfinul	1	S1	Delfinul	1936		650/900t, 68.6x5.9x3.7m, 2d/em, 800/800hp, 14/9kts, 40p, 80m; 1x1-102/35, 6-533TT
----	----------	---	----	----------	------	--	---

PRINCIPAL SURFACE COMBATANTS

DD	Mărăști	2	D1	Mărăști	1917		1723t, 94.7x9.5x3.6m, 5b,2st, 45000hp, 34kts, 139p; 2x2-120/45, (1x2+2x1)-37/83, 4x1-20/65, 2x2-13.2, 2x2-450TT, 1dct, 2dcr, 50mines
			D2	Mărășești	1918		
FS	74T	1	E2	Sborul	1914		320t, 58.2x5.7x1.5m, 2b,2st, 5000hp, 28kts, 41p; 1x1-66/30, 1x1-37/83, 1x1-20/65, 4dct, 2dcr
	82F	1	E1	Smeul	1916		330t, 58.8x5.8x1.5m, 2b,2st, 5000hp, 28kts, 41p; 1x1-66/30, 1x1-37/83, 1x1-20/65, 4dct, 2dcr

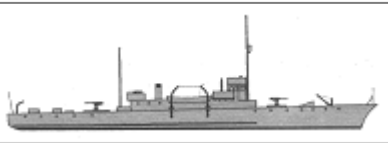
PATROL AND COASTAL COMBATANTS

PC	Friponne	2	DB1	Locotenent Lepri Remus	1918		443t, 60.2x7.0x2.6m, 2d, 900hp, 14.5kts, 50p; 1x1-88/45, 1x1-37/83, 1x1-20/65, 2dct, mines(1)
			DB2	Locotenant-Comandor Stihî Eugén	1917		
PBR	Căpitan Nicolae Lăscar Bogdan	3	V1-3	Horia, Cloșca, Crișan	1906-1907		51t, 30.4x4.0x0.8m, 2b,2vce, 550hp, 18kts, 20p; 1x1-47/44, sweeps

© Ivan Gogin, 2016

[home](#)[World navies yesterday](#)[1950](#)

South Africa 01 January 1950

PRINCIPAL SURFACE COMBATANTS

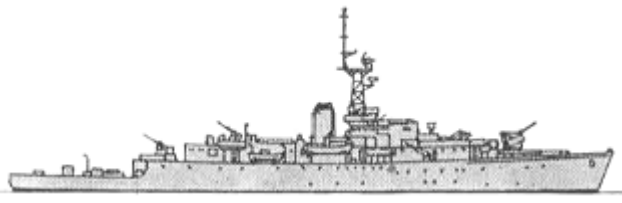
FF	Loch	3	K432	Good Hope	1944		2260t, 93.6x11.8x3.8m, 2b,2vte, 5500hp, 19.5kts, 177p; 1x1-102/45, 6x1-40/60, 1x4-40/39, 2x3-305 Squid ASWRL, 2dct, 1dcr; type 277, 291 radars, sonars
			K10	Natal	1945		
			K602	Transvaal	1945		

PATROL AND COASTAL COMBATANTS

PB	HDML	8	SDML1197-1204	-	1943		54t, 22.0x4.8x1.4m, 2d, 300hp, 11.8kts, 10p; 2x1-20/70, 2dcr; type 291 radar
----	------	---	---------------	---	------	--	--

MINE WARFARE

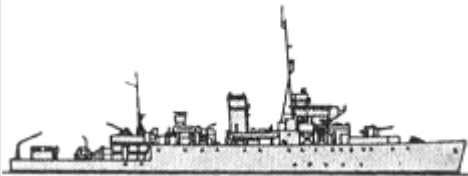





MSO	Algerine VTE	2	J439	Bloemfontein	1945		1325t, 68.6x10.8x3.3m, 2b,2vte, 2400hp, 16.5kts, 138p; 1x1-102/45, 4x2-20/70, 4dct, 2dcr, minesweeping gear; radar, sonar
			J291	Pietermaritzburg	1943		
	-	1	Spindrift	-	926t		



© Ivan Gogin, 2016

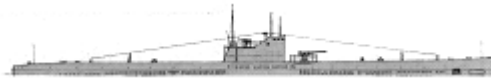



[home](#)[World navies yesterday](#)[1950](#)



Soviet Union 01 January 1950





SUBMARINES







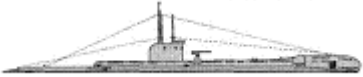
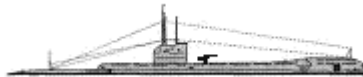

AG	1	1	M-52	1921		361/440t, 46.0x4.8x3.8m, 2d/em, 240/480hp, 12/8kts, 24p, 50m; 1x1-45/46, 4-450TT
ser. I	2	178	B-2	1931		933/1354(178)-989/1385(28)T, 76.0(178)-76.6(28)x6.4x3.8m, 2d/em, 2200/1050hp, 14/9(178)-11.3/8.7(28)kts, 47p, 75m; 1x1-100/51, 1x1-45/46, 8-533TT
		28/193	B-32	1931		
ser. II	3	197	B-3	1933		1051/1327(197)-1038/1330(31,32)t, 78.0(197,32)-78.5(31)x7.20(197,31)-7.0(32)x4.0(197)-4.2(31)-4.3(32)m, 2d/em, 2200/1300hp, 14.8/8.5(197)-12.5/8.2(31)-13.8/8.3(32)kts, 55p, 75m; 1x1-100/51, 1x1-45/46(197,32), 6-533TT, 20mines
		31/201	B-34	1933		
		32/202	B-35	1933		
ser. III	1	201	S-303	1933		578/706t, 57.0x6.2x3.9m, 2d/em, 1370/800hp, 12.5/8.5kts, 41p, 75m; 1x1-45/46, 6-533TT
ser. V	11	229	S-94	1933		585/700t, 58.5x6.2x3.9m, 2d/em, 1370/800hp, 11.9/8.5kts, 40p, 75m; 1x1-45/46, 1x1-12.7, 6-533TT, 20mines(233)
		159	S-92	1933		
		230	S-93	1933		
		234	S-105	1933		
		457	S-106	1933		
		458	S-107	1933		
		233	S-108	1933		
		455	S-109	1934		
		456	S-110	1934		
		232	S-111	1934		
		231	S-112	1934		
ser. Vbis	10	243/187	S-113	1934		601/722(185,225-227,241-244)-607/750(183,184)t, 58.0(185,225-227,241-244)-58.8(183,184)x6.2x3.9(185,225-227,241-244)-4.3(183,184)m, 2d/em, 1370/800hp, 12/8(185,225-227,241-244)-11.9/7.5(183,184)kts, 40p, 75m; 1x1-45/46, 1x1-12.7, 6-533TT, 20mines(225,242)
		244/188	S-114	1934		
		225	S-115	1934		
		242	S-116	1935		
		226	S-117	1934		
		227	S-118	1934		
		241	S-119	1935		
		185	S-120	1935		
		183/1026	S-201	1935		
		184/1027	S-202	1935		

ser. VI	25	237	M-1	1934		161/201t, 36.9x3.1x2.6m, 1d/em, 685/240hp, 11.1/6.4kts, 19p, 50m; 1x1-45/46, 2-533TT
		243	M-2	1934		
		236	M-3	1934		
		241	M-4	1934		
		245	M-5	1934		
		244	M-6	1934		
		242	M-7	1934		
		238	M-8	1934		
		240	M-9	1934		
		246	M-10	1934		
		252	M-11	1934		
		253	M-12	1934		
		254	M-13	1934		
		248	M-14	1934		
		247	M-15	1934		
		260	M-16	1934		
		257	M-17	1934		
		259	M-18	1934		
		258	M-19	1934		
		262	M-20	1934		
263/566	M-21	1934				
264/567	M-22	1934				
249	M-26	1934				
256	M-28	1935				
239	M-51	1934				
ser. Vbis-2	8	214	S-121	1935		618/721(214,215,217,251,252)-610/706(1029,1030)-589/708(550)t, 58.8(214,215,217,251,252,1029,1030)-57.8(550)x6.2x4.1(214,215,27,251,252)-4.3(1029,1030)-4.0(550)m, 2d/em, 1370/800hp, 11.9/6.7(214,215,217,251,252)-12.9/7.5(1029,1030)-12.3/8(550)kts, 40p, 75m; 1x1-45/46, 2x1-12.7, 6-533TT, 20mines(215,217,251)
		251	S-122	1935		
		215	S-123	1935		
		252	S-124	1935		
		217	S-125	1936		
		1029	S-205	1936		
		1031	S-207	1936		
		550/4	S-310	1936		
ser. Vlbis	6	287	M-47	1935		161/202t, 37.8x3.1x2.6m, 1d/em, 685/240hp, 13.2/7.2kts, 17p, 50m; 1x1-45/46, 2-533TT
		1047	M-48	1936		
		58	M-43	1935		
		60	M-44	1935		
		61	M-45	1935		
		62	M-46	1935		
ser. IV	2	219	B-31	1936		955/1690t, 87.7x8.0x2.9m, 2d/em, 5400/1100hp, 18.8/6.5kts, 56p, 50m; 2x1-100/51, 1x1-45/46, 6-533TT

		220	B-1	1936		
ser. X	14	297	S-126	1936		590/708t, 58.8x6.2x4.0m, 2d/em, 1600/800hp, 14/8.5kts, 40p, 75m; 1x1-45/46, 1x1-25/82(1039), 1x1-12.7, 6-533TT, 20mines(258,259,292)
		296	S-127	1936		
		258	S-128	1936		
		298	S-129	1936		
		257	S-130	1936		
		292	S-131	1936		
		299	S-132	1936		
		259	S-133	1936		
		293	S-134	1936		
		1033	S-209	1937		
		1039	S-215	1939		
		85	S-139	1937		
		262	S-404	1936		
		294	S-318	1936		
ser. XI	6	263	B-23	1936		1040/1335t, 79.9x7.0x4.0m, 2d/em, 2200/1300hp, 14.5/8.5kts, 55p, 75m; 1x1-100/51, 1x1-45/46, 6-533TT, 20mines
		264	B-24	1936		
		265	B-19	1936		
		285	B-10	1937		
		284	B-11	1938		
		286	B-12	1938		
ser. XII	19	255	M-30	1940		206/256t, 44.5x3.3x2.6m, 1d/em, 800/400hp, 14/8.2kts, 20p, 50m; 1x1-45/46, 2-533TT, 18mines(88)
		259	M-32	1940		
		269	M-35	1941		
		253	M-62	1940		
		88	M-171	1937		
		91	M-90	1938		
		136	M-102	1940		
		301	M-104 Yaroslavskiy Komsomolets	1943		
		302	M-105 Cheliabinskiy Komsomolets	1943		
		304	M-107 Novosibirskiy Komsomolets	1943		
		275	M-111	1941		
		276	M-112	1941		
		277	M-113	1941		
		280	M-114	1941		

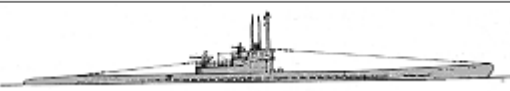
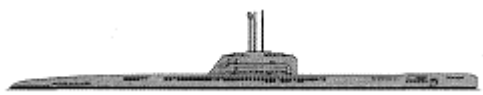
SS		281	M-115	1941			
		282	M-116	1941			
		287	M-117	1941			
		292	M-119	1942			
		289	M-120	1941			
	ser. XIII	5	273	B-13	1938		1120/1425t, 85.3x7.0x4.1m, 2d/em, 2200/1300hp, 15/9kts, 56p, 80m; 1x1-100/51, 1x1-45/46, 8-533TT, 18mines
			274	B-14	1938		
			305	B-15	1938		
			307	B-17	1939		
			275	B-18	1939		
	ser. IXbis	10	263	S-13	1941		845/1078t, 77.7x6.4x4.03m, 2d/em, 4000/1100hp, 19.4/9.5kts, 46p, 80m; 1x1-100/51, 1x1-12.7, 6-533TT
			347	S-31	1940		
			349	S-33	1940		
			360	S-35	1948		
			284	S-51	1941		
285			S-52	1943			
286			S-53	1943			
405			S-56	1941			
243			S-101	1940			
244			S-102	1940			
ser. IXbis-2	15	264	S-14 Geroicheskiy Sevastopol	1942		845/1078t, 77.7x6.4x4.03m, 2d/em, 4000/1100hp, 19.4/9.5kts, 46p, 80m; 1x1-100/51, 1x1-25/82(132), 1x1-12.7, 6-533TT; Tamir-5L sonar	
		271	S-15 Kolkhoznitsa	1942			
		272	S-16 Geroy Sovetskogo Soyuza Nurseitov	1943			
		273	S-17 Sovetskaya Svanetiya	1945			
		274	S-18	1945			
		132	S-19	1944			
		133	S-20	1945			
		134	S-21	1946			
		295	S-22	1946			
		296	S-23	1947			
		297	S-24	1947			
		298	S-25	1948			
		299	S-26	1948			
		265	S-103	1942			
266	S-104	1942					

ser. XIV	6	108	B-4	1940		1487/2110t, 97.8x7.4x4.0m, 2d/em, 8400/2400hp, 22.5/10.3kts, 66p, 80m; 2x1-100/51, 2x1-45/46, 10-533TT, 20mines
		454	B-5	1943		
		455	B-6	1942		
		456	B-7	1943		
		289	B-8	1944		
		290	B-9	1942		
Kalev	1	1	S-85	1937		665/853t, 59.5x7.2x3.5m, 2d/em, 1200/790hp, 13.5/8.5kts, 38p, 75m; 1x1-40/47, 4-533TT, 20mines
ser. Xbis	6	477	S-135	1941		589/705t, 58.8x6.4x4.0m, 2d/em, 1600/800hp, 14/8kts, 40p, 75m; 1x1-45/46, 1x1-12.7, 6-533TT
		478	S-136	1941		
		479	S-137	1941		
		512	S-407	1941		
		514	S-411	1945		
		515	S-412	1946		
ser. XIII-1938	3	302	B-20	1942		1108/1400t, 85.3x7.0x4.1m, 2d/em, 4000/1300hp, 18/9kts, 56p, 80m; 1x1-100/51, 1x1-45/46, 8-533TT, 20mines
		303	B-21	1943		
		304	B-22	1942		
ser. XV	28	122	M-200 Mest'	1943		280/351t, 49.5x4.4x2.8m, 2d/em, 1200/430hp, 15.5/7.9kts, 23p, 60m; 1x1-45/46, 4-533TT
		123	M-201	1943		
		138	M-202 Rybnik Donbassa	1944		
		139	Irkutskiy Rybak	1944		
		140	M-204	1947		
		141	M-205	1947		
		142	M-206	1947		
		113/306	M-214	1948		
		114/307	M-215	1947		
		115/308	M-216	1947		
		116/309	M-217	1947		
		117/310	M-218	1947		
		353	M-234	1948		
		354	M-235	1948		
		355	M-236	1948		
		373	M-237	1948		
		374	M-238	1948		
		375	M-239	1949		
376	M-240	1949				
377	M-241	1949				
378	M-242	1949				

			379	M-243	1949		
			380	M-244	1949		
			381	M-245	1949		
			382	M-246	1949		
			383	M-247	1949		
			384	M-248	1949		
			385	M-249	1949		
U	1	1		V-3	1942		646/732t, 60.0x4.9x4.7m, 2d/em, 615/825hp, 11.2/10kts, 33p, 60m; 1x1-76/45, 4-533TT; type 291W radar, sonar
Ursula	1	1		V-4	1938		630/730t, 58.2x4.9x4.6m, 2d/em, 615/825hp, 11.2/10kts, 27p, 60m; 1x1-76/45, 3x1-12.7, 6-533TT; sonar
Requinul	1	1		S-39	1943		585/789t, 58.0x5.6x3.6m, 2d/em, 1840/860hp, 17/8kts, 45p, 80m; 1x1-88/45, 1x1-20/65, 6-533TT
pr. 95	1	135		M-401	1945		161/202t, 37.3x3.3x1.7m, 2d, 2000hp, 19.1/12.5kts, 9p, 50m; 1x1-45/46, 2-533TT
ser. VIIC	2	1		S-81	1944		769/1070t, 67.1x6.2x4.7m, 2d/em, 3200/750hp, 17.7/7.6kts, 56p, 100m; 1x1-37/69, 2x2-20/65, 5-533TT, FuMO65 radar, sonar
		2		S-82	1944		
ser. VIIC/41	2	1		S-83	1944		769/1070t, 67.2x6.2x4.8m, 2d/em, 3200/750hp, 17.7/7.6kts, 44p, 120m; 1x1-37/69, 2x2-20/65, 5-533TT; FuMO65 radar
		2		S-84	1944		
ser. IXC/40	1	1		B-26	1944		1120/1257t, 76.8x6.9x4.7m, 2d/em, 4400/1000hp, 18.2/7.3kts, 48p, 100m; 1x1-37/69, 2x2-20/65, 6-533TT; FuMO65 radar
ser. XXI	4	1		B-27	1944		1621/1819t, 76.7x8.0x6.3m, 2d/em, 4000/4400hp, 15.6/17.2kts, 57p, 135m; 2x2-20/65, 6-533TT; FuMO65 radar
		2		B-28	1945		
		3		B-29	1945		
		4		B-30	1945		
ser. XXIII	1	1		M-31	1945		234/258t, 34.7x3.0x3.7m, 1d/em, 630/580hp, 9.7/12.5kts, 14p, 80m; 2-533TT
Flutto	1	1		S-41	1943		930/1093t, 63.2x7.0x4.9m, 2d/em, 2400/800hp, 16/8kts, 50p, 120m; 1x1-100/47, 2x1-20/70, 6-533TT
Acciaio	1	1		S-42	1942		697/850t, 60.2x6.4x4.8m, 2d/em, 1400/800hp, 14/7.7kts, 45p, 80m; 1x1-100/47, 2x1-20/70, 6-533TT
SSX	SH	1	1	i	1948		15/17t, 11.9x1.7x1.5m, 1d/em, 60/25kts, 7.7/6kts, 2p, 50m; 2-533TC



PRINCIPAL SURFACE COMBATANTS

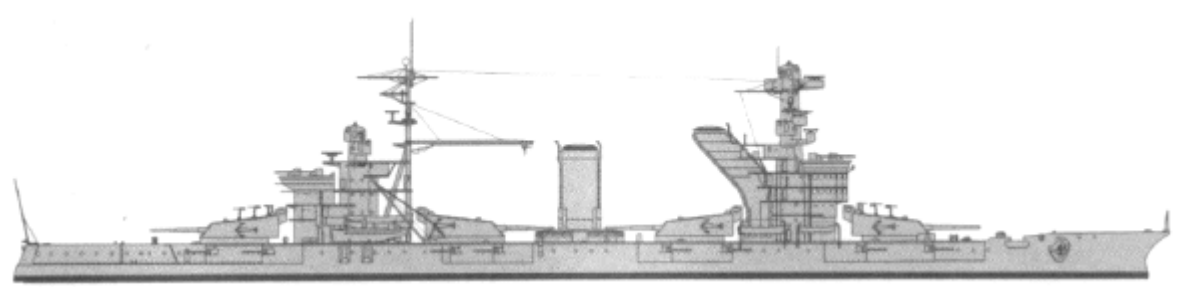
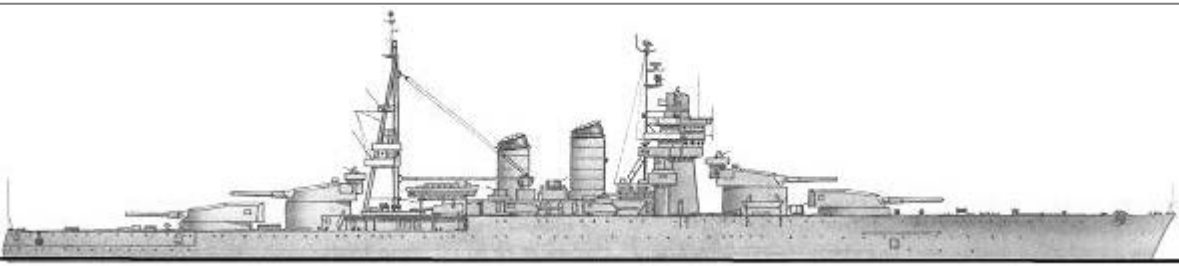
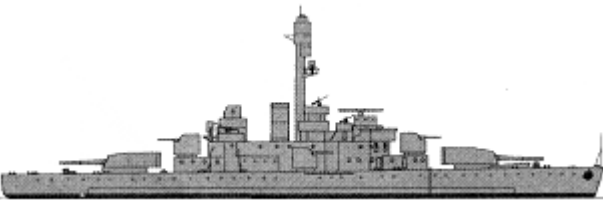
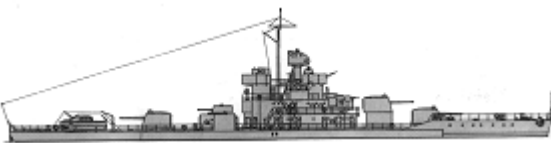
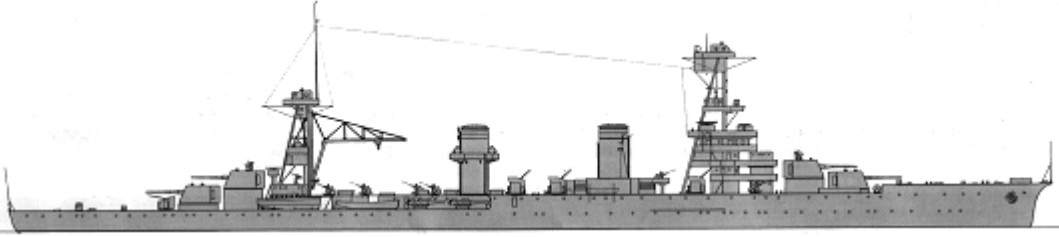
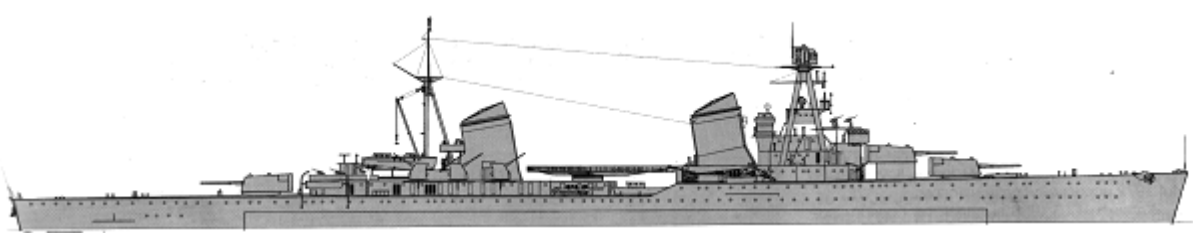
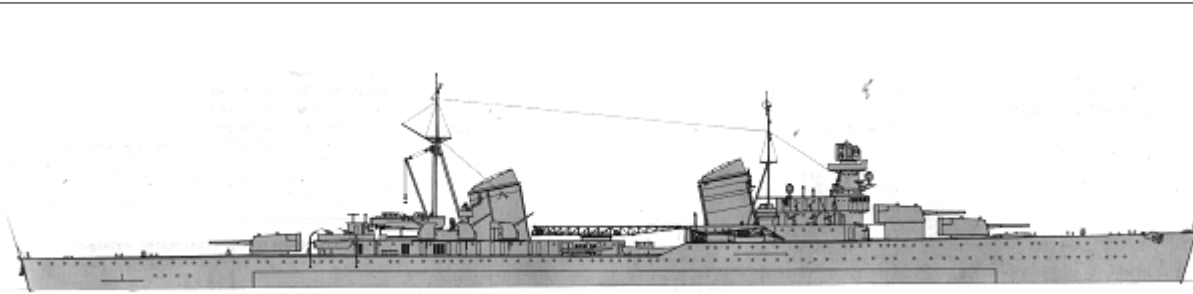

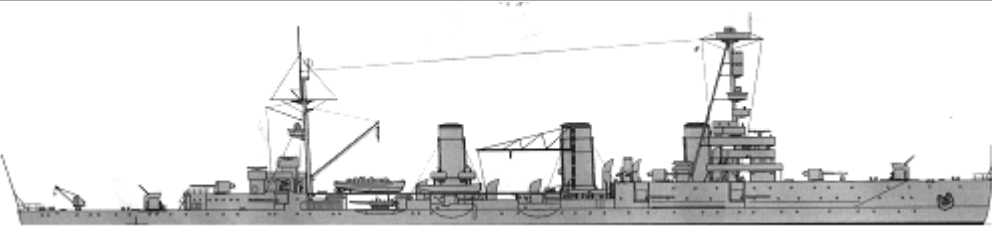
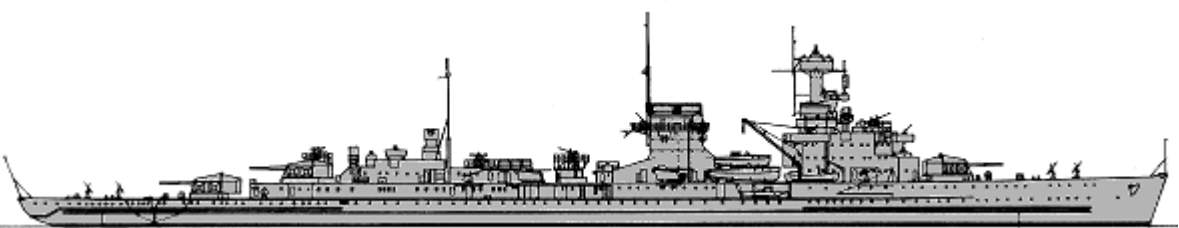
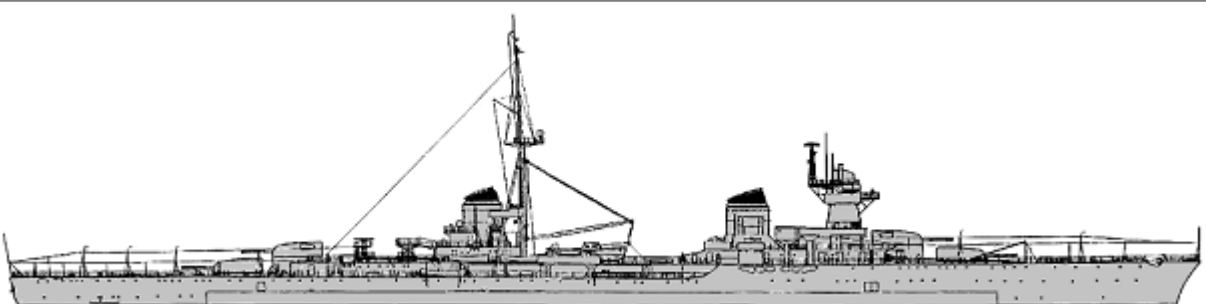
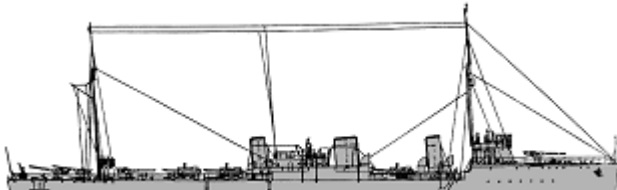
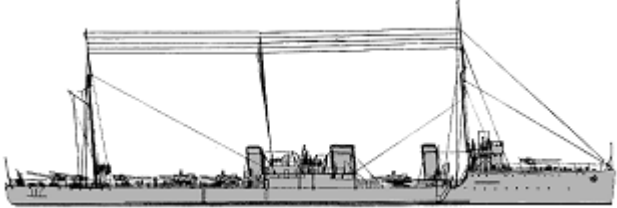
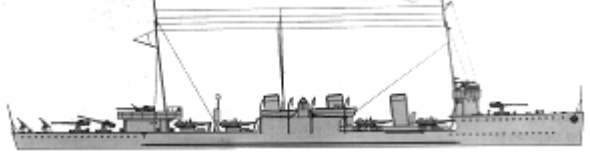
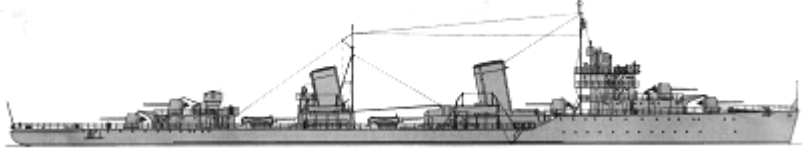

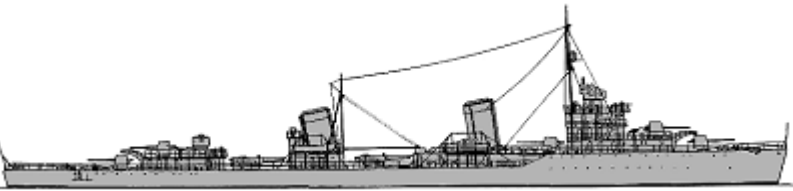
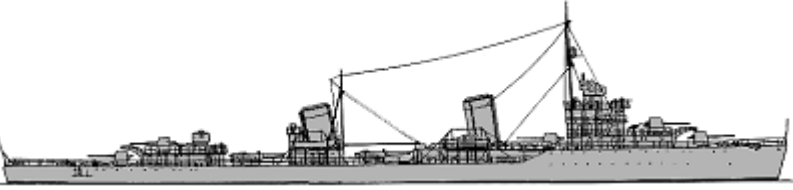
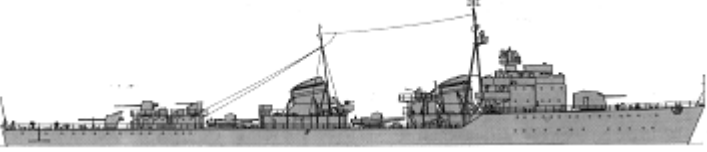
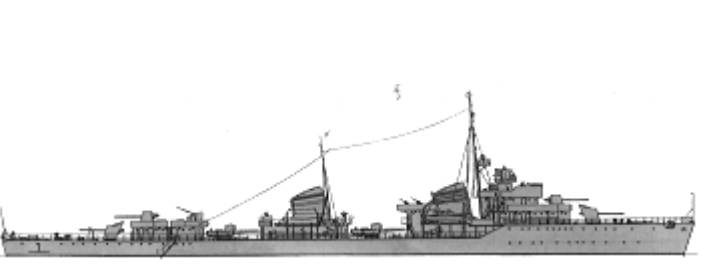

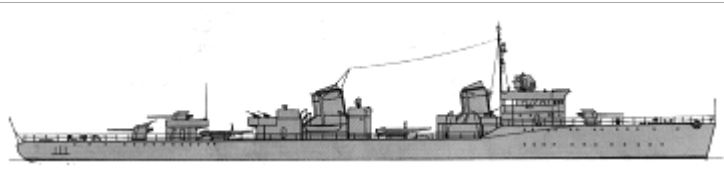
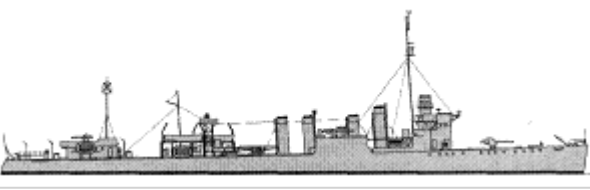

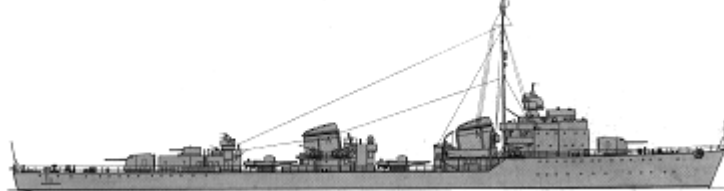
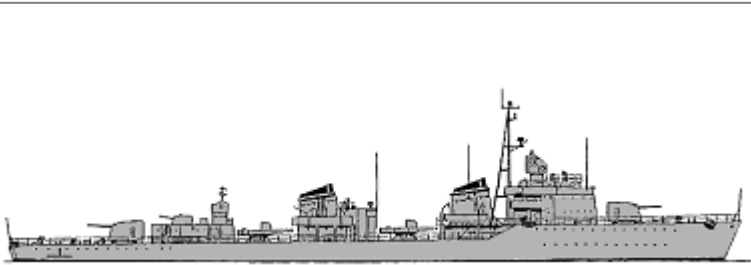
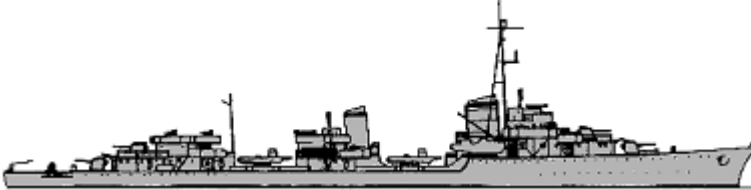
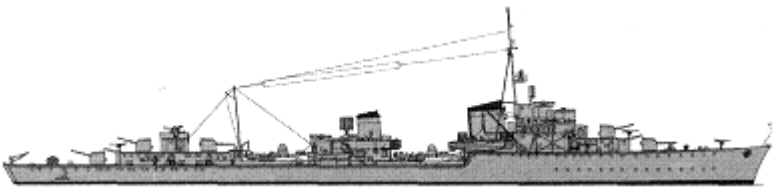
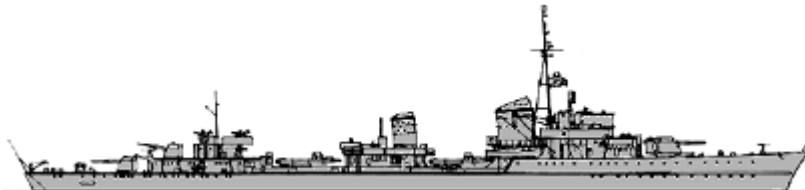
		1	Oktiabrskaya Revoliutsiya	1914		26692(1)-30395(2)t, 184.9x26.9(1)-32.5(2)x9.2m, 12b,4gst, 60600hp, 22.5kts, 1140p; 225belt, 37(1)-87(2)decks, 305turrets, 250CT; 4x3- 305/52, 10x1-120/50(1), 16x1-120/50(2),
	Sevastopol	2				

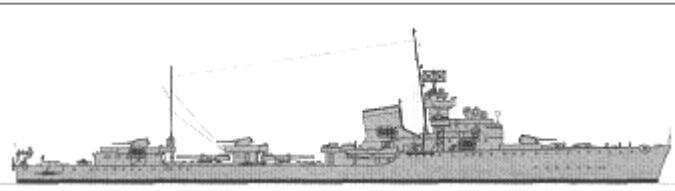

BB			2	Sevastopol	1914		(3x2+6x1)-76/55(1), 6x1-76/55(2), (1x4+16x1)-37/73(1), 16x1-37/73(2), (2x4+2x2+4x1)-12.7(1), 8x1-12.7(2), 1seaplane(Be-4)(1), 2seaplanes(Be-4)(2), SG-1(1), type 281, 284(1) radars
	Giulio Cesare	1	3	Novorossiysk	1914		29100t, 186.4x28.6x9.2m, 8b,2gst, 93000hp, 28kts, 1236p; 250belt, 144decks, 280turrets, 260CT; (2x3+2x2)-320/44, 6x2-120/50, 4x2-100/47, 8x2-37/54, 8x2-20/65
BC	Ilmarinen	1	1	Vyborg	1932		3900t, 93.0ppx16.9x4.5m, 4dg,2em, 6000hp, 15kts, 330p; 55belt, 20deck, 100turrets, 120CT; 2x2-254/45, 4x2-105/50, (1x2+2x1)-40/60, 8x1-20/60
MON	pr. 1190	3	233/9671	Khasan	1942		2400t, 88.0x11.1x2.9m, 4d, 3200hp, 15kts, 242p; 77belt, 40deck, 100turrets, 100CT; 3x2-130/51, 2x2-76/55, 2x2-45/46, 5x2-12.7/79, 29mines
			234/9672	Perekop	1943		
			235/9673	Sivash	1946		
CA	Krasnyy Kavkaz	1	1	Krasnyy Kavkaz	1932		8888t, 169.5x15.7x6.6m, 10b,4st, 55000hp, 29kts, 850p; 75belt, 45decks, 25turrets, 75CT; 4x1-180/59, 6x2-100/47, 14x1-37/73, 4x3-450TT, 100mines
	pr. 26	2	269	Kirov	1938		9287(269)-9400(297)t, 191.3x17.7x6.2m, 6b,2gst, 110000hp, 35kts, 734p; 50belt, 50deck, 50turrets, 150CT; 3x3-180/58, 8x1-100/56(269), 6x1-100/56(297), 11x1-37/73(269), 12x1-37/73(297), (2x4+6x1)-12.7(269), (2x4+4x1)-12.7(297), 2x3-533TT, 4dct, 2dcr, 100mines; type 281(297), 2x 282, 284, 2x 285, 291 radars
			297	Voroshilov	1940		
	pr. 26bis	4	270	Maksim Gorkiy	1940		9575-9882t, 191.4x17.7x5.9-6.3m, 6b,2gst, 110000hp, 35kts, 897p; 70belt, 50deck, 70turrets, 150CT; 3x3-180/58, 6x1-100/56(270,329), 8x1-85/52(7,8), 15x1-37/73(270), 12x1-37/73(329), 19x1-37/73(7), 21x1-37/73(8), (2x4+4x1)-12.7(270,329), 6x1-12.7(7,8), 2x3-533TT, 4dct(270), 2dcr(270), 100mines, 2seaplanes(Be-4)(329,7,8), 2x type 282(270,7,8), 284(270), 2x 285(270,8),
329			Molotov	1941			
7			Kalinin	1942			
		8	Lazar' Kaganovich	1944			

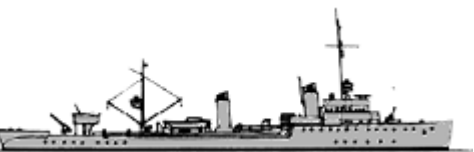
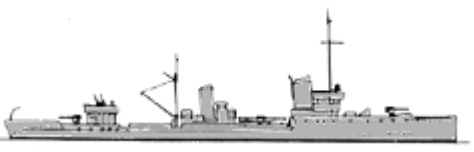
						291(270,8), Redut-K(329), Mars-1(329), SG(7,8), 281(7,8), 2x Yupiter-1(7) radars
CL	Profintern	1	1	Krasnyy Krym	1928	 8041t, 158.4x15.4x6.7m, 13b,4st, 46300hp, 29kts, 830p; 75belt, 40decks, 25shields, 75CT; 15x1-130/55, 3x2-100/47, 14x1-37/73, (2x4+14x1)-12.7, 2x3-533TT, 90mines, type 291 radar
	Nürnberg	1	2	Admiral Makarov	1935	 8900t, 181.3x16.4x4.9m, 8b,3gst+4d, 60000+12400=72400hp, 32kts, 896p; 50belt, 25deck, 80turrets, 100CT; 3x3-149/61, 4x2-88/76, 2x1-40/60, 6x2-37/83, (2x4+10x2)-20/65, 2x3-533TT, 120mines; FuMO21, FuMO25, FuMO63 radars
	Emanuele Filiberto Duca d'Aosta	1	3	Kerch'	1935	 10374t, 186.9x17.5x6.5m, 6b,2gst, 110000hp, 36.5kts, 694p; 105belt, 35decks, 90turrets, 100CT; 4x2-152/53, 3x2-100/47, 4x2-37/54, 12x1-20/70, 2dct, 112mines; type 286 radar
	Pobeditel	1	1	Uritskiy	1915	 1450t, 98.0x9.3x3.2m, 4b,2st, 30000hp, 35kts, 112p; 4x1-102/60, 4x1-37/73, 2x1-20/70, 4x1-12.7, 3x3-450TT, 2dct, 2dcr, 58mines
	Kapitan Izylmetyev	2	2	Valerian Kuybyshev	1927	
			3	Karl Libknekht	1928	
	Fidonisi	1	4	Zheleznyakov	1925	 1760t, 92.5x9.1x3.8m, 5b,2st, 29000hp, 33kts, 136p; 4x1-102/60, 2x1-76/30, 2x1-45/69, 5x1-37/73, 2x1-20/70, 2x1-12.7, 4x3-450TT, 2dcr, 60mines
	pr. 1	1	450	Leningrad	1936	 2582t, 127.5x11.7x4.1m, 3b,3gst, 66000hp, 36kts, 250p; 5x1-130/51, (1x2+2x1)-76/55, 6x1-37/73, 8x1-12.7, 2x4-533TT, 2dcr, 76mines; type 284 radar
		502	Groznyy	1938		

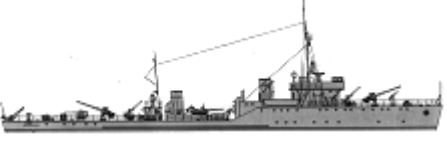

pr. 7	19	503	Gromkiy	1938		2039t, 112.8x10.2x3.3m, 3b,2gst, 48000hp, 37(298,312-314,319, 321,323-328,502, 503,513,516,1075)-35(315,515)kts, 246p; 4x1-130/50, 2x1-76/55(298,312-314,319, 321,323-328,502, 503,516,1075), 3x1-76/55(513), 3x1-37/73(298,312,313,319,323-325, 327,328,516), 4x1-37/73(502,503), 5x1-37/73(314,321), 6x1-37/73(513), 7x1-37/73(326,1075), 4x2-37/70(315,515), (1x2+2x1)-12.7(513), 4x1-12.7/79(298,312,313,319,323-325,327,328,516), (2x2+2x1)-12.7(314,321,326,502,503,1075), 2x3-533TT, 2dct, 2dcr, 56(298,312-314,319, 321,323-328,502, 503,513,516,1075)mines, 60mines(315,515); type 286M(326,502,503,1075), Gyuys-1(315,515), Rif-1(315,515), Vympel-2(315,515) radars, type 128(298,312-314,319, 321,323-328,502, 503,513,516,1075), Tamir-5N(315,515) sonar
		513/301	Groziashchiy	1939		
		515	Gremiashchiy	1938		
		516	Steregushchiy	1939		
		312	Rastoropnyy	1940		
		313	Raziashchiy	1940		
		314	Bodryy	1938		
		315	Ryanny	1939		
		319	Rezkiy	1942		
		321	Boykiy	1939		
		323	Retivyy	1941		
		324	Reshitelnyy	1941		
		325	Revnostnyy	1941		
		326	Razyarionnyy	1941		
		327	Rekordnyy	1941		
328	Redkiy	1942				
298	Rezvy	1940				
1075	Razumnyy	1941				
pr. 38	1	471	Minsk	1939		2597t, 127.5x11.7x4.1m, 3b,3gst, 66000hp, 36kts, 250p; 5x1-130/51, (1x2+3x1)-76/55, 8x1-37/73, 6x1-12.7, 2x4-533TT, 2dcr, 76mines; type 285, SG radars
pr. 38bis	2	267	Baku	1939		2597t, 127.5x11.7x4.1m, 3b,3gst, 66000hp, 36kts, 250p; 5x1-130/51, 3x1-76/55, 11x1-37/73(267), 8x1-37/73(268), 4x1-12.7(267), 6x1-12.7(268), 2x4-533TT, 2dcr, 76mines; type 285, SG radars
		268	Tbilisi	1940		
pr. 7U/30	1	517	Storozhevoy	1940		2453t, 113.5x10.2x5.0m, 4b,2gst, 54000hp, 36kts, 273p; (1x2+2x1)-130/51, 3x1-76/55, 6x1-37/73, 4x1-12.7, 2x3-533TT, 2dct, 2dcr, 56mines
pr. 7U	8	518	Vitse-admiral Drozd	1940		2404t, 112.8x10.2x5.0m, 4b,2gst, 54000hp, 36kts, 273p; 4x1-130/51, 3x1-76/55(293,518-520,523,525,527), 4x1-37/73(519,525), 6x1-37/73(293,518,520,523,527), 8x1-37/73(1078), 3x1-12.7(293,518,520), 4x1-12.7(519,523,525,527), 6x2-12.7(1078), 2x3-533TT, 2dct, 2dcr, 56mines
		519	Strashnyy	1941		
		520	Silnyy	1940		
		523	Strogiy	1942		
		525	Svirepyy	1941		
		527	Stroynnyy	1942		
		293	Slavnyy	1941		
		1078	Soobrazitelnyy	1941		

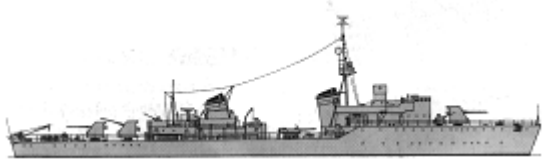
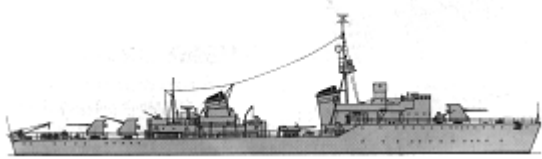

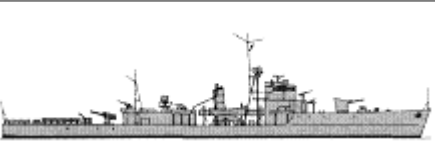

DD	pr. 45	1	500	Opytnyy	1941		2016t, 113.5x10.2x3.4m, 4b,2gst, 70000hp, 42kts, 262p; 3x1-130/51, 4x1-45/46, 3x1-37/73, (1x2+2x1)-12.7, 2x4-533TT, 2dcr, 60mines
	Wickes	3	1	Zhguchiy	1919		1390t, 95.8x9.4x2.8m, 4b,2gst, 26000(1,3)-27000(2)hp, 35kts, 146p; 3x1-102/50(1), 1x1-102/50(2,3), 1x1-76/50, 2x1-20/70(2), 4x1-20/70(3), 3x1-12.7, 2x3-533TT(1), 1x3-533TT(2,3), 1x24-178 Hedgehog ASW RL(2), 4dct, 2dcr; radars, sonar
			2	Doblestnyy	1919		
			3	Druzhnyy	1918		
	Regina Maria	2	1	Letuchiy	1930		1850t, 102.0x9.6x3.5m, 4b,2gst, 48000hp, 35kts, 212p; 4x1-120/50, 1x1-88/45, 2x1-40/67, 4x1-20/65, 2x2-13.2, 2x3-533TT, 2dct, 2dcr, 50mines; S-Gerät sonar
			2	Likhoy	1930		
	pr. 30	1	1056	Ognevoy	1945		2767t, 115.5x11.0x4.7m, 4b,2gst, 54000hp, 37kts, 293p; 2x2-130/51, 1x2-76/55, 6x1-37/73, 4x1-12.7, 2x3-533TT, 2dct, 2dcr, 60mines
	pr. 30K	8	103	Osmotritelnyy	1947		2860t, 117.0x11.0x4.7m, 4b,2gst, 54000hp, 36.5kts, 301p; 2x2-130/51, 1x2-85/52, 6x1-37/73, 2x3-533TT, 2dct, 2dcr, 60mines; Giuys-1b, Rif-1, Vympel-2, Rym-1 radars, Tamir-5N sonar
			104	Stalin	1948		
3			Vnushitelnyy	1947			
4			Vynoslivyy	1948			
5			Vlastnyy	1948			
538			Otlichnyy	1948			
539			Obraztsovyy	1949			
1087			Ozornoy	1949			
Z14	1	1	Prytkiy	1938		3165t, 121.0x11.3x4.2m, 6b,2gst, 67000hp, 38kts, 315p; 4x1-128/45, 7x2-37/69, (1x4+3x2)-20/65, 2x4-533TT, 4dct, 60mines	
Z20	1	1	Prochnyy	1939		3415t, 125.1x11.8x4.5m, 6b,2gst, 70000hp, 38.5kts, 330p; 5x1-128/45, 2x2-37/69, 2x1-37/57, (1x4+2x2+1x1)-20/65, 2x4-533TT, 4dct, 60mines	
Z33	1	1	Provornyy	1943		3691t, 127.0x12.0x3.9m, 6b,2gst, 70000hp, 36kts, 332p; (1x2+3x1)-149/46, 6x2-37/69, 2x1-37/57, (1x4+2x2+2x1)-20/65, 2x4-533TT, 4dct, 60mines	

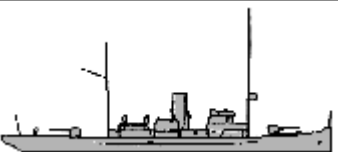

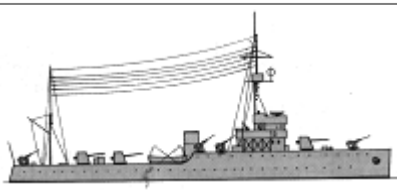
Soldati	2	1	Lovkiy	1938		2460t, 106.7x10.2x3.5m, 3b,2gst, 48000hp, 38kts, 206p; (2x2+1x1)-120/50(1), 2x2-120/50(2), 2x1-37/54(2), (4x2+5x1)-20/65, 2x3-533TT(1), 1x3-533TT(2), 4dct, 48mines; EC.3/ter radar
		2	Liogkiy	1939		
pr. 30bis	8	1101	Bditelnyy	1949		3066t, 120.5x12.0x4.3m, 4b,2gst, 60000hp, 35.5kts, 286p; 2x2-130/51, 1x2-85/52, 7x1-37/73(6,9,12,601,1101), 4x2-37/70(178,179,1102), 2x5-533TT, 6dct, 2dcr, 60mines; Giuys-1M, P-10, Rif-1, Rym-1, Redan, Vympel-2, Redan-4(601) radars, Tamir-5N sonar
		1102	Bezuderzhnyy	1949		
		6	Vstrechnyy	1949		
		9	Vedushchiy	1949		
		12	Vazhnyy	1949		
		601	Smelyy	1949		
		178	Ognennyy	1949		
		179	Otchotlivyy	1949		
T12	1	1	Podvizhnyy	1940		1082t, 87.1x8.6x2.3m, 4b,2gst, 31000hp, 35kts, 119p; 1x1-105/45, 1x2-37/69, (2x4+4x1)-20/65, 1x3-533TT, 2dct, 30mines; FuMO28 radar
T33	1	1	Primernyy	1944		1754t, 102.5x10.0x2.7m, 4b,2gst, 29000hp, 206p; 4x1-105/45, 2x2-37/69, (1x4+5x1)-20/65, 2x3-533TT, 2dct, 50mines; FuMO21, FuMO63 radars
G7	1	1	Porazhayushchiy	1912		884t, 76.1x7.6x3.1m, 3b,2st, 16000hp, 30kts, 74p; 1x1-105/45, 2x1-20/65, (1x2+1x1)-500TT, 18mines
V158	1	1	Prozorlivyy	1908		691t, 72.5x7.8x3.0m, 4b,2vte, 10900hp, 30kts, 84p; 1x1-88/45, 1x1-20/65
Animoso	3	1	Ladnyy	1942		1683t, 87.8x9.9x3.8m, 2b,2gst, 16000hp, 26kts, 177p; 3x1-100/47(1), 2x1-100/47(2,3), (3x2+6x1)-20/70(1), (4x2+5x1)-20/70(2,3), 2x2-450TT, 6dct(1), 4dct(2,3), 20mines(1)
		2	Liuty	1942		
		3	Liotnyy	1942		
pr. 2	2	324	Groza	1932		534t, 71.5x7.4x2.5m, 2b,2gst, 6300hp, 26kts, 85p; 2x1-102/60, 2x1-45/46(187), 3x1-37/73, 2x1-12.7(324), 3x2-12.7, 1x3-450TT, 2dct(324), 2dcr, 32mines; type 291 radar, sonar
		187	Shkval	1933		
pr. 4	4	423	Metel'	1934		531t, 71.5x7.4x2.3m, 2b,2gst, 6300hp, 25kts, 101p; 2x1-102/60, 3x1-37/73, 1x1-20/70(424), 3x2-12.7(423,220,221), 2x2-12.7(424), 1x3-450TT, 2dct, 2dcr, 32mines; type 291 radar, sonar
		424	Vyuga	1934		
		220	Grom	1935		
		221	Burun	1935		
		478	Molniya	1936		568t, 71.5x7.4x2.4m, 2b,2gst, 6300hp, 24kts,



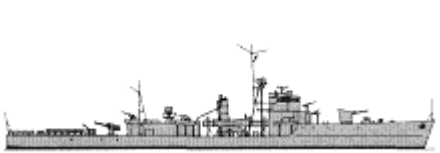





FF	pr. 39	2	479	Zarnitsa	1936		101p; 2x1-102/60, 3x1-37/73, 3x2-12.7, 1x3-450TT, 2dct, 2dcr, 24mines; type 291 radar, sonar
	pr. 29	1	530	Yastreb	1945		1248t, 85.7x8.4x2.9m, 2b,2gst, 26000hp, 32kts, 174p; 3x1-100/54, 6x1-37/73, 4x2-12.7, 1x3-450TT, 2dcr, 24mines; radar, Tamir-5N sonar
	pr. 29K	2	1	Burevestnik	1947		1266t, 85.7x8.4x2.9m, 2b,2gst, 26000hp, 31kts, 171p; 3x1-100/56, 6x1-37/73, 4x2-12.7, 1x3-450TT, 2dcr, 24mines; radar, Tamir-5N sonar
			2	Albatros	1945		
	Tacoma	3	1	EK-12	1944		2238t, 92.6x11.4x3.9m, 3b,2vte, 5500hp, 20kts, 190p; 3x1-76/50, 2x2-40/60, 9x1-20/70, 1x24-178 Hedgehog ASWRL, 8dct, 2dcr; SA, SU, Mk26 radars, sonar
2			EK-17				
3			EK-27				
D	4	1	EK-32	1944		940t, 69.5x8.6x3.1m, 2b,1gst, 2500hp, 17.5kts, 160p; 2x1-120/45, (2x3+2x2+4x1)-25/60, 1x1-81/12 ASWmortar, 12dct; 22-go, 13-go radars	
		2	EK-33	1945			
		3	EK-36	1944			
		4	EK-37	1946			













PATROL AND COASTAL COMBATANTS

PG	Ukrayna	3	1	Bakinskiy Rabochiy	1905		880t, 73.2x7.2x3.4m, 4b,2vte, 7000hp, 26kts, 88p; 3x1-102/60, 2x1-45/46, 2x1-37/73, 4x1-12.7, 25mines
			2	Markin	1905		
			3	3-y DOSAAF	1905		
	Kopchik	1	1	Pioner	1916		550t, 51.2x7.3x2.9m, 3b,2vte, 1500hp, 15kts, 57p; 2x1-102/60, 1x1-76/30, 30mines
	Khrabryy	1	1	Krasnoe Znamia	1897		2100t, 72.3x12.7x3.4m, 8b,2vte, 2100hp, 14kts, 188p; Harvey-127belt, 38deck, 38shields, 25CT; 5x1-130/51, 6x1-45/46, 1x1-37/73, (2x4+2x1)-12.7, 50mines
Kars	2	1	Lenin	1910		635t, 61.6x8.5x2.6m, 2d, 2200hp, 15kts, 128p; 3x1-100/56, 4x1-37/73(1), 6x1-37/73(2), (2x2+2x1)-12.7(1), 2x1-12.7(2), 30mines	
		2	Krasnyy Azerbaydzhan	1910			
							320t, 47.5x8.0x1.5m, 2d, 400hp,

	Indigirka	1	1	Moskovskiy Komsomol	1920		8.5kts, 67p; 2x1-75/50
DV	Shimushu	1	1	PS-25	1940		1020t, 77.7x9.1x3.1m, 2d, 4200hp, 19.7kts, 150p; 3x1-120/45, 5x3-25/60, 1x1-76 ASWRL, 2dct
	D	2	1	Arkhara	1946		940t, 69.5x8.6x3.1m, 2b,1gst, 2500hp, 17.5kts, 160p; 2x1-120/45, (2x3+2x2+4x1)-25/60, 1x1-81/12 ASWmortar, 12dct; 22-go, 13-go radars
			2	Abakan	1945		
pr. 122A	30	307	BO-102	1941		250t, 50.4x5.8x2.1m, 3d, 3600hp, 21kts, 54p; 1x1-85/52(exc 307,337,338,343,344), 1x1-76/55(307,337,338,343,344), 2x1-37/73, 2x2-12.7(exc 307,337,338,343,344), 3x1-12.7(307,337,338,343,344), 2dct, 1dcr; Tamir-1 sonar	
		343	BO-103	1942			
		338	BO-105	1942			
		337	BO-106	1942			
		344	BO-107	1943			
		354	BO-108	1945			
		355	BO-109	1945			
		356	BO-110	1945			
		31	BO-122	1945			
		32	BO-123	1946			
		33	BO-124	1946			
		34	BO-125	1946			
		35	BO-126	1946			
		36	BO-127	1946			
		140	BO-131	1944			
		141	BO-132	1944			
		142	BO-133	1944			
		152	BO-137	1944			
		153	BO-138	1944			
		154	BO-139	1945			
155	BO-140	1945					
156	BO-141	1945					
157	BO-142	1945					
158	BO-143	1946					
159	BO-144	1946					
160	BO-145	1946					
163	BO-148	1946					
164	BO-149	1947					
166	BO-151	1947					

PC	122bis	32	167	BO-152	1947		325t, 51.7x6.6x2.2m, 3d, 3600hp, 20kts, 54p; 1x1-85/52, 2x1-37/73, 2x2-12.7, 2dct, 2dcr, 18mines; Giuys or Zarnitsa radar, Tamir-9 sonar
			368	BO-171	1947		
			379	BO-172	1947		
			380	BO-173	1948		
			436	BO-181	1948		
			437	BO-182	1948		
			438	BO-183	1948		
			439	BO-184	1948		
			440	BO-185	1948		
			442	BO-187	1948		
			443	BO-188	1948		
			445	BO-190	1948		
			446	BO-191	1948		
			447	BO-192	1949		
			448	BO-193	1949		
			449	BO-194	1949		
			450	BO-195	1949		
			451	BO-196	1949		
			454	BO-199	1949		
			455	BO-200	1949		
			456	BO-201	1949		
			457	BO-247	1949		
			458	BO-248	1949		
			459	BO-249	1949		
			460	BO-250	1949		
			461	BO-251	1949		
			462	BO-252	1949		
			463	BO-253	1949		
			464	BO-254	1949		
			465	BO-255	1949		
			367	BO-270	1947		
			466	BO-271	1949		
467	BO-272	1949					
APC	-		1	LK-1	1905		140t
	pr. SB-30	1	1	Aktivnyy	1935		314t, 50.7x8.2x1.1m, 2d, 480hp, 8.5kts, 68p; 30belt, 16deck, 30turret, 30CT; 1x2-102/45, 2x2-45/46, 1x1-37/73, 3x1-12.7
	pr. SB-37	1	1	Zheleznyakov	1936		263t, 51.2x8.2x0.9m, 2d, 280hp, 8.3kts, 78p; 16belt, 4deck, 30turret, 30CT; 1x2-102/45, (1x2+1x1)-45/46, 2x1-37/73,

							(1x4+2x1)-12.7
RMON	Ion C. Bratianu	2	1	Azov	1907		750t, 63.5x10.5x1.8m, 2b,2vte, 1800hp, 13.5kts, 119p; 75belt, 75deck, 75turrets, 75CT; 3x1-120/50, 5x1-37/73, 2x1-20/70(1), 4x1-20/70(2), 4x1-12.7(1)
			2	Mariupol	1908		
	Temes	1	1	Berdyansk	1905		650t, 59.0x9.5x1.6m, 2b,2vte, 1400hp, 10kts, 129p; 70belt, 70deck, 50turrets, 75CT; 3x1-120/50, 4x1-37/73, 4x1-20/70
	Sava	1	1	Izmail	1915		700t, 62.2x10.5x1.7m, 2b,2vte, 1600hp, 12kts, 125p; 40belt, 60deck, 50turrets, 50CT; 2x2-120/44, 5x1-37/73, 2x1-20/70, 4x1-12.7
	Inn	1	1	Kerch'	1915		770t, 62.0x10.5x1.8m, 2b,2vte, 1600hp, 12.2kts, 133p; 40belt, 35deck, 50turrets, 40CT; 2x2-120/50, 5x1-37/73, 2x1-20/70, 4x1-12.7
	Tayfun	7	1	Dzerzhinskiy	1910		1000t, 70.9x12.8x1.4m, 4d, 1870(1,4,7)-1000(2)-2970(3,5,6)hp, 11.3(1,4,7)-10(2)-16.5(3,5,6)kts, 117p; 76belt, 19deck, 76turrets, 51CT; 4x1-152/50(6), 4x1-130/55(1,3,4), 4x2-120/50(2,5,7), 2x1-85/42(3,5,7), 2x1-76/30(6), 2x1-37/73(1,2,4-7), 4x1-37/73(3), 6x1-20/70(3,5,7), 4x1-12.7(1,4,6), (1x2+3x1)-12.7(2)
2	Lenin		1910				
3	Dalnevostochnyy Komsomolets		1910				
4	Kirov		1910				
5	Krasnyy Vostok		1910				
6	Sverdlov		1910				
7	Suchan		1910				
PR	Buriat	1	1	Buriat	1907		288t, 54.5x8.2x0.9m, 2b,2vte, 480hp, 11.5kts, 40p; 12belt, 5deck, 8CT; 2x1-76/40, 2x1-37/73, 2x1-12.7
	Vogul	2	1	Krasnaya Zvezda	1909		349t, 54.5x8.2x1.2m, 2d, 480(1)-800(2)hp, 12(1)-14(2)kts, 63p; 13belt, 9deck, 13CT; 3x1-100/56, 3x1-37/73(1), 2x1-37/73(2), 4x1-20/70(2), 3x2-12.7(1)
			2	Krasnoe Znamia	1909		
	Shun Tien	4	1	Bashkiriya	1934		270(1,3)-290(2,4)t, 55.8(1,3)-59.4(2,4)x8.8x0.9m, 2d, 680(1,3)-800(2,4)hp, 12.5(1,3)-13(2,4)kts, 70p; (1x2+1x1)-120/45, 2x1-70/12, 3x2-13.2, 2dct, 80mines
2			Buriat-Mongoliya	1935			
3			Yakutiya	1934			
4			Chuvashiya	1935			
G-5	98?		?TK-73 Yunyy Tambovets, 83 Tambovskiy Remeslennik, 115 Altayskiy Shkolnik, 125 Altaets, 135 Tyumenskiy Rabochiy, 145 Kazanskiy Rechink, 305-308, 312 Tyumenskiy Rabochiy, 313-316, 326, 333, 335, 336 Morshanets, 354 Chkalovskiy Komsomolets, 355, 381, 383-385, 395, 396 Trudyashchiysya Kirgizii, 457-459, 462 Tambovets, 531-536, 541-546, 572, 574, 581-586, 592-596, 601, 602, 611-616, 631-636, 641-647, 661-665, 671-676, 691, 692, 694, 801, 803-808		1939 -		17-20t, 19.1x3.3-3.4x1.0-1.2m, 2pe, 1700-2000hp, 45-52kts, 6-7p; (1-2)x1-12.7, 2-533TT
			TK-16, 17, TK-20 Dzerzhinets, 36, 56, 60, TK-96 Irtys, 114, 116, 121, 126, TK-136 Geroy		1944		

PT	D-3	25	Sovetskogo Soyuza Kuzin, 172, TK-183 Narodnyy Uchitel`, TK-185 Michurinets, TK-188 Dalnevostochnyy Moryak, TK-189 20-letie Proletarskoy Revolyutsii, TK-190 Krasnodarskiy Vodhozovets, 192, TK-193 Barnaulskiy Kolkhoznik, TK-195 Lenskiy Rechnik, TK-197 Mordovskiy Komsomolets, TK-198 Tambovskiy Komsomolets, TK-199 Tambovskiy Pioner, 403	1941 - 1945		36t, 22.4x4.0x1.8m, 3pe, 2550-3600hp, 32-48kts, 9p; 1x1-20/65, 2x2-12.7, 2-533TT, 4dc
	pr. 123	1	TK-351	1940		17t, 18.5x3.4x1.2m, 2pe, 2400hp, 51kts, 7p; 1x1-12.7, 2-533TT
	G-8	1	G-8	1940		31t, 24.2x3.8x1.5m, 4pe(2), 4000hp, 32kts, 10p; 3x1-12.7, 2-533TT
	SM-3	1	SM-3	1941		34t, 20.8x3.9x1.3m, 3pe, 3600hp, 30kts, 8p; 2x1-12.7, 2-533TT
	Higgins	46	TK-202, 204-208, 210, 211, 213, 215, 216, 218, 219, 222, 851-882	1942 - 1945		48t, 24.0x6.1x1.6m, 3pe, 4500hp, 41kts, 17p; 1x1-40/60, 2x1-20/70, 4-533TT; SO or SCR-517A radar
	pr. 123bis	120?	?TK-7 Odesskiy Patriot, 8-12, 21-30, 46, 95, 100 Odesskiy Kolkhoznik, 110-112, 120, 122, 123, 130, 131 Rechik Angary, 133 Trudyashchiysya Artyoma, 140, 141 Odesskiy Komsomolets, 142, 143, 146, 148, 188-191, 271-301, 317-320, 327-332, 337, 350 Chernomorets, 352-380, 386-420, 460-471, 472 Moriak Dalstroya, 473 Livadiya, 474-512, 551-558, 574, 575, 597, 599, 601-606, 607 Komsomol Kazakhstana, 608 Pioner Kazakhstana, 609, 687-690, 721-740, 940-957, 972, 980-995	1944 - 1948		21t, 18.7x3.4x1.2m, 2pe, 2400hp, 48kts, 7p; 2x2-12.7, 2-450TT
	TM-200	5?	?TK-450 Yunga, 451-454	1944 - 1945		47t, 23.4x4.4x1.7m, 3pe, 3600hp, 30.7kts, 11p; 3x2-12.7, 2-533TT
	Vosper	57	TK-220, 221, 223, 225, 227, 229, 231-236, 238, 252-272, 527, 517, 539, 559-561, 563, 566, 567, 580, 587-590, 597, 809-814	1943 - 1944		45t, 22.1x5.9x1.7m, 3pe, 3375hp, 39kts, 11p; 1x1-20/70, 2x2-12.7, 2-533TT, 2dc; SO or SCR-517A radar
	ELCO	60	TK-417-419, 420-447, 484-510, 520, 530	1943 - 1945		61t, 24.4x6.3x1.6m, 3pe, 4500hp, 43kts, 17p; 1x1-40/60 or 1x1-37/71, 2x1-20/70, 2x2-12.7, 2-533TT, 2dc; SO or SCR-517A radar
	No4	2	?TK-963, 964	1940 - 1943		38t, 21.4x6.1x1.1m, 3pe, 3300hp, 40kts, 14p; 2x1-20/80, 2-533TT, 2dcr
	TD-200	1	?TK-16	1946		46t, 23.4x4.7x1.6m, 3pe, 3600hp, 38kts, 11p; 3x2-12.7, 2-533TT, 2dcr
	TD-200bis	84?	?TK-17-20, 31, 32, 36, 37, 40, 42, 47, 49-54, 74-78, 86, 91, 92, 96, 121, 126, 134, 149, 169, 170, 180-187, 202-220, 255-266, 421-433?	1947 - 1949		47t, 23.7x4.7x1.6m, 3d, 3000hp, 38kts, 11p; 3x2-12.7, 2-533TT
	TM-200bis	17	TK-455-459, 708-711, 741-750	1946 - 1948		46t, 23.4x4.0x1.7m, 3pe, 3600hp, 38kts, 11p; 3x2-12.7, 2-533TT, 4dc
			1	TK-1005	1941	
		2	TK-1006	1942		
		3	TK-1001	1942		
		4	TK-1008	1942		
					115t, 34.9x5.3x1.7m, 3d, 7500hp,	

S50	10	5	TK-1009	1942		41kts, 31p; 1x1-40/60 or 1x1-37/83, (1x2+1x1)-20/65, 2-533TT, 2dcr, 6mines				
		6	TK-1010	1943						
		7	TK-1011	1940						
		8	TK-1012	1941						
		9	TK-1017	1943						
		10	TK-1018	1943						
		S16	1	1			TK-1003	1937		105t, 34.6x5.3x1.7m, 3d, 6150hp, 37.7kts, 23p; 1x1-40/60, (1x2+1x1)-20/65, 2-533TT, 6dc
		S24	1	1			TK-1004	1939		105t, 34.6x5.3x1.7m, 3d, 6000hp, 39.8kts, 23p; 1x1-37/83, (1x2+1x1)-20/65, 2-533TT, 6dc
		S175	7	1			TK-1019	1944		122t, 34.9x5.3x1.7m, 3d, 7500hp, 41kts, 31p; 1x1-40/60, (1x2+1x1)-20/65, 2-533TT, 2dcr, 6mines
				2			TK-1020	1944		
3	TK-1021			1944						
4	TK-1022			1944						
5	TK-1023			1944						
6	TK-1024			1944						
7	TK-1025			1944						
S701	1	1	TK-1029	1945		124t, 34.9x5.3x1.7m, 3d, 9000hp, 43.6kts, 31p; 1x1-40/60, (1x2+1x1)-20/65, 2-533TT, 2dcr, 6mines				
pr. M123bis	14?		?TK-697, 940-952	1949		22t, 18.7x3.4x0.8m, 2d, 2000hp, 50kts, 7p; 2x2-12.7, 2-450TT, 6dc				
pr. 183	28?		?TK-20, 27, 28, 61-67, 69, 72, 97, 112-114, 151-161, 172	1949		67t, 25.5x6.2x1.2m, 4d, 4800hp, 43kts, 14p; 2x2-25/112, 2-533TT, 8dc; Zarnitsa radar				
MAS516	2		TK-975, 976	1937		24t, 17.0x4.4x1.3m, 2pe, 2000hp, 42kts, 9p; 1x1-13.2, 2-450TT, 6dc				
MS52	5		TK-970-974	1943		66t, 28.0x4.3x1.6m, 3pe, 3450hp, 31kts, 19p; 2x2-20/65, 2-533TT, 2-450TT, 8dc				
MAS440	1		TK-979	1935	No picture	42t, 22.5x4.3x1.4m, 2pe, 2000hp, 32kts, 19p; 1x1-13.2, dcr				
pr. 161	14	1	BK-505	1943		158t, 36.2x5.5x1.3m, 2pe, 2400hp, 13kts, 38p; 50belt, 30deck, 45turrets, 8CT; 2x1-76/42, 2x1-45/69, 1x1-37/73, 2x1-12.7				
		2	BK-506	1943						
		3	BK-507	1943						
		4	BK-508	1943						
		5	BK-510	1943						
		6	BK-511	1944						
		7	BK-512	1944						
		8	BK-513	1944						
		9	BK-515	1944						

			10	BK-516	1944		
			11	BK-517	1944		
			12	BK-518	1944		
			13	BK-519	1944		
			14	BK-520	1944		
PG	pr. 186	35	1	BK-521 Komsomolets Armenii	1945		166t, 36.2x5.2x1.5m, 2d, 1000hp, 14kts, 42p; 20belt, 20deck, 90turrets, 20CT; 2x1-85/55, 1x1-37/73, 2x2-12.7, 2x1-82/12mortars
			2	BK-522	1945		
			3	BK-523	1945		
			4	BK-524	1945		
			5	BK-525	1945		
			6	BK-526	1945		
			7	BK-527	1945		
			8	BK-528	1945		
			9	BK-529	1946		
			10	BK-530	1946		
			11	BK-531	1946		
			12	BK-532	1946		
			13	BK-533	1946		
			14	BK-534	1946		
			15	BK-535	1946		
			16	BK-536	1946		
			17	BK-537	1946		
			18	BK-538	1946		
			19	BK-539	1946		
			20	BK-540	1946		
			21	BK-541	1947		
			22	BK-542	1947		
			23	BK-543	1947		
			24	BK-544	1947		
			25	BK-545	1947		
			26	BK-546	1947		
			27	BK-547	1947		
			28	BK-548	1947		
			29	BK-549	1947		
			30	BK-550	1947		
			31	BK-554	1947		
			32	BK-555	1947		
			33	BK-556	1947		
			34	BK-557	1947		
			35	BK-558	1947		
			1	BO-201	1943		



2	BO-202	1943
3	BO-203	1943
4	BO-204	1943
5	BO-205	1943
6	BO-206	1943
7	BO-207	1943
8	BO-208	1943
9	BO-209	1943
10	BO-210	1943
11	BO-211	1943
12	BO-212	1943
13	BO-213	1944
14	BO-214	1944
15	BO-215	1944
16	BO-216	1944
17	BO-217	1944
18	BO-218	1944
19	BO-219	1944
20	BO-220	1944
21	BO-221	1944
22	BO-222	1944
23	BO-223	1944
24	BO-225	1944
25	BO-226	1944
26	BO-227	1944
27	BO-228	1944
28	BO-231	1944
29	BO-232	1944
30	BO-233	1944
31	BO-234	1944
32	BO-235	1944
33	BO-236	1944
34	BO-237	1944
35	BO-238	1944
36	BO-239	1944
37	BO-240	1944
38	BO-241	1944
39	BO-242	1944
40	BO-243	1944
41	BO-244	1944









SC

72







136t, 33.8x5.5x2.0m, 2d, 2400hp,
21kts, 33p; 1x1-40/60, 3x1-20/70,
2x4-178 Mousetrap ASWRL, 2dct,
2dcr; SU radar, QC sonar

			42	BO-245	1944		
			43	BO-246	1944		
			44	BO-301	1943		
			45	BO-303	1942		
			46	BO-304	1942		
			47	BO-305	1943		
			48	BO-307	1942		
			49	BO-308	1942		
			50	BO-309	1942		
			51	BO-310	1942		
			52	BO-311	1942		
			53	BO-312	1943		
			54	BO-313	1942		
			55	BO-314	1942		
			56	BO-315	1943		
			57	BO-316	1942		
			58	BO-317	1943		
			59	BO-318	1942		
			60	BO-319	1942		
			61	BO-321	1942		
			62	BO-322	1942		
			63	BO-323	1943		
			64	BO-324	1943		
			65	BO-325	1943		
			66	BO-326	1942		
			67	BO-327	1943		
			68	BO-328	1943		
			69	BO-329	1944		
			70	BO-331	1943		
			71	BO-332	1943		
			72	BO-335	1943		
	R163	3	1	BO-51	1941		
			2	BO-53	1943		128t, 36.2x5.6x1.4m, 2d, 1800hp, 23.5kts, 31p; 1x1-37/83, (2x2+2x1)-20/65, 2dcr, 10mines, sweeps
			3	BO-54	1943		
	R37	1	1	BO-52	1939		126t, 35.4x5.6x1.4m, 2d, 1800hp, 23.5kts, 20p; 1x1-37/83, (2x2+2x1)-20/65, 2dcr, 10mines, sweeps
	Vosper	16		SK-764-779	1943 1944		45t, 22.1x5.9x1.7m, 3pe, 3375hp, 39kts, 11p; 1x1-20/70, 2x2-12.7, 2dc; SO or SCR-517A radar
					1943		40t, 22.2x4.0x1.8m, 3pe, 2285hp,





PP-19-OK	30		MO-600, 601, 603 Yunga Severa, 604-614, SK-52, 72, 82, 132, 142 Staryy Bolshevik, 152, 171-174, 176, 177, 179, 180, 272, 282	- 1945		24kts, 11p; 1x1-37/73, 2x2-12.7, 2x4-82 M-8 RL, 2dcr
OD-200	53		MO-216-221, 224-227, 229, 233, 234, 237-240, 242-247, 250, 317, 321, 322, 354-359, 362, 378, 379, 389, 393, 398, 461, 462, 554, 565, 567, SK-631, 633, 635-640, USK-324	1943 -		47t, 23.4x4.0x1.8m, 2pe/2pe(2), 2400/170hp, 24kts, 21p; 1x1-37/73, 2x2-12.7, 2dcr
pr. 194	54		MO-418, 501, 502, 504, 505, 507-509, 513-516, 518, 519, 520 Chkalovets, 521 Yunyy Chkalovets, 523 Khabarovskiy Komsomol, 525 Geroy Sovetskogo Soyuza Kotov, 526, 528, 529, 530 Konstruktor-Sudostroitel, 531-537, 538 Sovetskiy Staratel, 539-541, 543-545, 621-638	1943 -		55t, 24.8x4.2x1.6m, 2pe/1pe, 2400/68hp, 21kts, 22p; 10belt, 12deck, 12CT; 1x1-37/73, 3x2-12.7, 2dcr
OD-200bis	55		MO-270-289, 292-300, 310, 641-658, 660, 661-663, 691, 692, 694	1946 -		48t, 23.4x4.0x1.8m, 2d, 2000hp, 29kts, 16p; 1x1-37/73, 2x1-12.7, 2dcr
VAS245	2		SK-748, 750	1943		69t, 28.0x4.7x1.3m, 3pe, 1750hp, 21.5kts, 26p; 2x1-20/65, 2-450TT, sweeps
A	20		SK-11-17, 21-26, 661-667	1942 -		8t, 15.6x3.0x0.6m, 1pe, 63hp, 8kts, 6p; 1x1-12.7
BKM-2	5		SK-651-655	1943 -	No picture	58t, 23.0x3.5x1.2m, 2d, 500hp, 12kts, 16p; 1x1-37/73, 1x2-12.7
PTC	54		SK-230-258, 436, 438, 440-442, 444-458, 521-523, 526, 527	1943 -		27t, 19.2x4.6x1.2m, 2pe, 1260hp, 25kts, 12p; 1x1-20/70, 2x2-12.7, 8dc
R23	1	1	SK-341	1938		124t, 37.0x5.8x1.4m, 2d(vs), 1800hp, 21kts, 27p; (2x2+2x1)-20/65, 2dcr, 12mines, sweeps
R65	12	1	SK-342	1941		135t, 38.6x5.8x1.4m, 2d(vs), 1800hp, 20kts, 38p; 1x1-37/83, 3x1-20/65, 2dcr, sweeps
		2	SK-343	1941		
		3	SK-344	1942		
		4	SK-345	1942		
		5	SK-346	1942		
		6	SK-473	1940		
		7	SK-474	1940		
		8	SK-475	1941		
		9	SK-353	1941		
		10	SK-476	1942		
		11	SK-477	1943		
		12	SK-478	1943		
R149	1	1	SK-347	1944		155t, 41.1x5.8x1.6m, 2d(vs), 1800hp, 19kts, 41p; 1x1-37/83, (2x2+2x1)-20/65, 2dcr, sweeps
		1	SK-348	1943		
		2	SK-349	1944		
		3	SK-350	1944		184t, 41.0x6.0x1.8m, 2d, 3750hp,

R305	8	4	SK-351	1944		23.5kts, 42p; 1x1-37/83, (3x2+1x1)-20/65, 2x1-86 R Ag M42/43 RL, 2-533TT, 16mines, 2dcr, sweeps
		5	SK-462	1943		
		6	SK-463	1943		
		7	SK-464	1944		
		8	SK-465	1944		
R417	14	1	SK-352	1945		150t, 39.4x5.7x1.5m, 2d, 2800hp, 25kts, 37p; 1x1-37/69, 3x2-20/65, 2x1-86 R Ag M42/43 RL, 12mines, 2dcr, sweeps
		2	SK-492	1944		
		3	SK-493	1944		
		4	SK-494	1945		
		5	SK-495	1945		
		6	SK-496	1945		
		7	SK-466	1944		
		8	SK-467	1945		
		9	SK-468	1945		
		10	SK-469	1945		
		11	SK-470	1945		
		12	SK-471	1945		
		13	SK-472	1945		
		14	SK-482	1944		
R234	11	1	SK-485	1943		148t, 39.4x5.7x1.5m, 2d, 2500hp, 21kts, 40p; 1x1-37/83, 3x2-20/65, 12mines, 2dcr, sweeps
		2	SK-486	1944		
		3	SK-487	1944		
		4	SK-488	1944		
		5	SK-489	1945		
		6	SK-490	1945		
		7	SK-461	1945		
		8	SK-479	1944		
		9	SK-480	1945		
		10	SK-481	1944		
		11	SK-482	1945		
R28	1	1	SK-484	1938		126t, 35.4x5.6x1.4m, 2d, 1800hp, 23.5kts, 20p; 1x1-37/83, (2x2+2x1)-20/65, 2dcr, 10mines, sweeps
Pulia	2		BK-93, 94	1910		25t, 22.2x3.1x0.5m, 2pe, 200hp, 14.5kts, 12p; 8belt, 8deck, 8CT; 1x1-76/16
K	4		BK-71, 73-75	1917		25t, 20.4x3.2x0.6m, 2pe, 1600hp, 15kts, 12p; 5belt, 4deck, 6shields, 6CT; 2x1-76/16
Partizan	2		BK-91, 92	1932	No picture	56t, 32.0x3.4x0.9m, 2pe, 1600hp, 22kts, 13p; 5belt, 5CT; 1x1-76/30
						52t, 25.3x4.0x0.9m, 2pe, 1500hp,

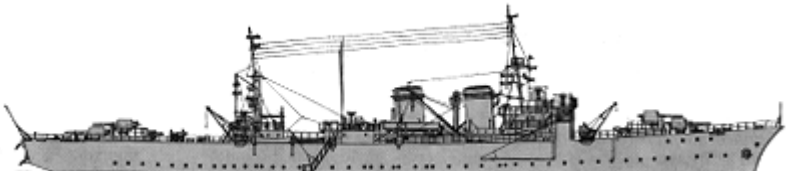
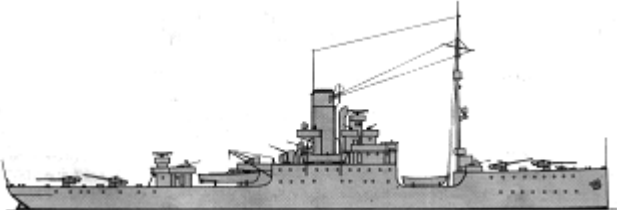

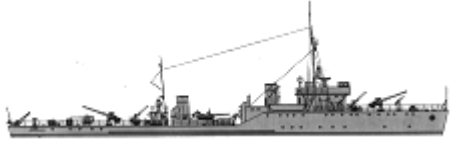

PGR	pr. 1124	35?		BK-20, 47, 48, 67, 71, 103, 115, 154, 158-160, 162 Eyskiy Patriot, 163 Saratovskiy Patriot, 164 Bolgradets, 165 Izmailets, 221, 308 Trudyashchiysya Tatarii, 309, 310, 314, 318-320, 335, 337, 339, 343, 344, 346, 422 Stalinets, 431, 434-437	1943 - 1946		18kts, 17p; 7belt, 4deck, 45turrets, 8CT; 2x1-76/42, 1x1-37/73, 1x2-12.7
	pr. 1125	83?		BK-13, 14, 44, 76 Borodinets, 77 Reniyskiy Patriot, 78, 79, 85, 86, 87 Tuzlovskiy Patriot, 88 Kiliyskiy Patriot, 89 Kiliets, 90 Starokazitskiy Patriot, 93, 104-111, 139, 140, 141 Tuzlovets, 142 Trudyashchiysya Kili, 143 Dunayskiy Patriot, 144 Otvet Izmaila, 145 Borodinskiy Patriot, 146 Rechnik Volgotankera, 147 Reniets, 148-153, 155-157, 186, 225-233, 239, 241-243, 261-266, 301, 302, 304, 305 Molotovskiy Remeslennik, 306, 307, 313, 322, 358, 359, 371-385	1943 - 1947		30t, 22.7x3.5x0.6m, 1pe, 750hp, 19.7kts, 13p; 7belt, 4deck, 45turret, 7CT; 1x1-76/42, 1x2-12.7
	S-40	3?		BK-323, 331, 333	1942		37t, 24.7x3.9x0.6m, 2d, 800hp, 19kts, 13p; 7belt, 4deck, 45turret, 7CT; 1x1-76/42
	Hsin Ya	3		BK-125-127	1940	No picture	65t, 29.7x4.0x0.8m, 2d, 240hp, 14kts, 20p; 5belt, 5CT; 2x1-45/69, 2x1-12.7
	Hsiao Chaing	3		BK-128-130	1935	No picture	30t, 19kts; 5belt, 5CT; 1x1-45/69, 2x1-12.7
	Ta Tung	2		SK-265, 266	1933	No picture	56t, 30.5x4.9x0.8m, 2d, 240hp, 10.5kts, 20p; 1x1-57/16
	Hai Min	3		SK-267-269	1933	No picture	15t, 18.2x3.4x0.8m, 1d, 80hp, 11kts
	pr. 191	1		BK-166	1947		57t, 25.9x4.3x0.7m, 2d, 1200hp, 16kts, 14p; 14belt, 10deck, 30turret, 14CT; 1x1-85/55, 2x2-12.7
	pr. 191M	52?		?BK-167-174, 439-444, 446, 447, 451-454, 459-462, 464-466, 468, 475-481, 486 and others	1948 - 1949		57t, 26.0x4.4x0.7m, 2d, 2000hp, 20.8kts, 15p; 14belt, 10deck, 30turret, 14CT; 1x1-85/55, 2x2-14.5, 8mines



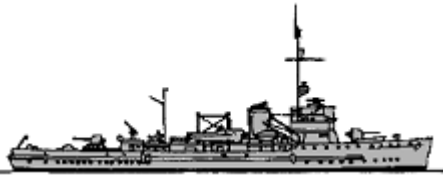
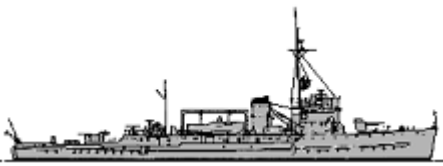
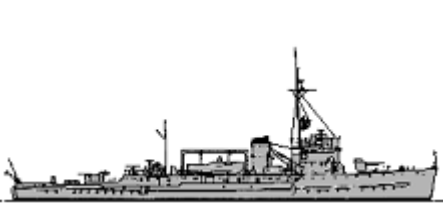

MINE WARFARE SHIPS

ML	Shtandart	1	1	Oka	1896		6189t, 122.3x15.4x7.0m, 4b,2vte, 11426hp, 18kts, 390p; 4x1-130/55, 7x1-76/55, 3x1-45/46, 3x1-12.7, 390mines
AML	-	5	1	Argun'	1923		5400t, 97.0x13.7x5.5m, 2b,1vte, 1550hp, 11kts; 4x1-130/55, 3x1-76/30, 4x1-37/73, 530mines
			2	Astrakhan'	1913		3725t, 91.1x12.3x5.2m, 2b,1vte, 1150hp, 9.8kts; 2x1-102/60, 2x1-76/30, 1x1-45/46, 820mines
			3	Ayan	1935		1975t, 74.0x10.4x3.3m, 2d, 750hp, 9kts; 1x1-76/30, 2x1-45/46, 200mines
			4	Voroshilovsk	1907		2300t, 63.5x10.0x4.6m, 2b,1vte, 750hp, 10.5kts; 4x1-76/30, 268mines
			5	Gizhiga	1937		1600t, 74.1x10.4x3.3m, 2d, 750hp, 9kts; 1x1-76/30, 2x1-45/46, 138mines

NL	pr. 149	4	1	Viatka	1941		527t, 56.8x9.8x1.7m, 3d, 330hp, 8.3kts, 54p; 3x1-45/46, 2x1-12.7(1,2), 1x4-12.7(3,4), 50mines, nets
			2	Onega	1941		
			3	Mologa	1944		
			4	Sukhona	1944		
	pr. 2	1	321	Tayfun	1931		534t, 71.5x7.4x2.5m, 2b,2gst, 6300hp, 26kts, 85p; 2x1-100/54, 2x1-37/73, 3x2-12.7, 2dct, 2dcr, 32mines, mechanical sweeping gear; type 291 radar, sonar
	pr. 39	1	496	Tucha	1938		568t, 71.5x7.4x2.4m, 2b,2gst, 6300hp, 24kts, 101p; 2x1-102/60, 2x1-37/73, 3x2-12.7, 2dct, 2dcr, 24mines, mechanical sweeping gear; type 291 radar, sonar
	pr. 59	2	108	Vladimir Polukhin	1942		879t, 79.2x8.1x2.5m, 2b,2gst, 8000hp, 22.4kts, 125p; 2x1-100/56, 1x1-45/46, 3x1-37/73, 2x1-20/70, 4x1-12.7, 2dcr, 20mines, mechanical sweeps
23			Vasiliy Gromov	1943			
	pr. 73K	12	111	Karl Zedin	1948		863t, 78.6x8.1x2.5m, 2d, 3200hp, 17.5kts, 119p; 2x1-85/52, 4x1-37/73, 4x1-12.7, 2dct, 20mines, mechanical, magnetic, acoustic sweeps; Giuys-1M, Zarnitsa, Rym radars, Tamir-5 sonar
26			Vladimir Trefolev	1947			
124			Timofey Ulyantsev	1949			
125			Mikhail Martynov	1948			
29			Fiodor Mitrofanov	1947			
30			Luka Pankov	1948			
31			Pavlin Vinogradov	1949			
32			Stepan Griadushko	1949			
33			Semion Pelikhov	1949			
249			EMTShch-15	1948			
251			EMTShch-11	1948			
253	EMTShch-13	1948					
			1	Starshiy Leytenant Lekarev	1943		
			2	Starshiy Leytenant Vladimirov	1943		
			3	T-113	1943		
			4	T-115	1943		
			5	T-116	1943		

MSO	Admirable	19	6	T-117	1943		945t, 56.2x10.1x3.0m, 2d, 2000hp, 15.1kts, 96p; 1x1-76/50, 2x1-40/60, 6x1-20/70, mechanical, magnetic, acoustic sweeps					
			7	T-119	1943							
			8	T-279	1944							
			9	T-281	1944							
			10	T-284	1944							
			11	T-285	1943							
			12	T-332	1943							
			13	T-333	1944							
			14	T-334	1944							
			15	T-335	1944							
			16	T-336	1944							
			17	T-337	1944							
			18	T-338	1943							
			19	T-339	1943							
			MSO	M1940	28			1	T-701	1945		775t, 62.3x8.9x2.3m, 2b,2vteet, 2615hp, 17.2kts, 75p; 2x1-105/45, 2x1-37/83, (1x4+2x1)-20/65, 4dct, 2dcr, 12mines, sweeps
								2	T-703	1942		
								3	T-704	1942		
								4	T-705	1944		
								5	T-706	1942		
6	T-707	1943										
7	T-708	1942										
8	T-709	1942										
9	T-710	1942										
10	T-711	1943										
11	T-712	1944										
12	T-713	1943										
13	T-714	1943										
14	T-715	1943										
15	T-716	1943										
16	T-717	1943										
17	T-718	1943										
18	T-719	1942										
19	T-720	1943										
20	T-722	1942										
21	T-723	1943										
22	T-724	1943										
23	T-725	1943										
24	T-726	1943										
25	T-727	1943										
26	T-728	1943										
27	T-729	1943										

		28	T-730	1943		
M1935	2	1	T-912	1938		874t, 68.1x8.7x2.1m, 2b,2se, 3500hp, 18.1kts, 84p; 2x1-105/45, 1x2-37/83, (1x4+4x2)-20/65, 30mines, 2dct, sweeps
		2	T-921	1940		
M1938	2	1	T-914	1940		908t, 71.0x9.2x2.1m, 2b,2se, 3200hp, 18.1kts, 97p; 2x1-105/45, (1x4+4x2)-20/65, 30mines, 2dct, sweeps
		2	T-920	1943		
M1939(Mob)	6	1	T-915	1941		878t, 68.4x8.7x2.1m, 2b,2se, 3700hp, 18.3kts, 119p; 2x1-105/45, 1x2-37/83, (1x4+4x2)-20/65, 30mines, 2dct, sweeps
		2	T-916	1941		
		3	T-917	1941		
		4	T-919	1941		
		5	T-923	1942		
		6	T-924	1942		
pr. 254	7	90	T-43	1948		569t, 58.0x8.5x2.3m, 2d, 2200hp, 14kts, 65p; 2x2-37/70, 4x2-12.7, 2dct, 2dcr, 16mines, mechanical, magnetic, acoustic sweeps; Rif, Rym-K radars, Tamir-10 sonar
		91	T-44	1949		
		92	T-45	1949		
		93	T-46	1949		
		105	T-47	1949		
		106	T-48	1949		
		111	T-92	1949		
pr. 3	2	67	Tral	1936		445t, 62.0x7.2x2.0m, 2d, 2800hp, 18.5kts, 42p; 1x1-100/51, 1x1-45/46, 3x1-37/73, 2x1-12.7, 2dcr, 31mines, sweeps
		70	Shchit	1937		
pr. 53	8	491/111	Strela	1938		503t, 62.0x7.2x2.3m, 2d, 2800hp, 17.8kts, 44p; 1x1-100/56, 1x1-45/46(176,178), 3x1-37/73(178-180,491-494), 2x1-12.7(176,178), 4x1-12.7(179,180,491-494), 2dcr, 31mines, sweeps
		492/112	Tros	1938		
		494/114	Podsekatel	1938		
		493/113	Provodnik	1938		
		179	Vekha	1938		
		180	Cheka	1938		
		176	Iskatel	1938		
		178	Mina	1938		
pr. 53U	10	14	Gafel	1939		480t, 62.0x7.4x2.2m, 2d, 2900hp, 18.2kts, 47p; 1x1-100/56, 1x1-45/46(16,19,20,22,24,35,36), 1x1-37/73(28), 2x1-37/73(14,34), 2x1-20/70(14,16,19,20,22,24,25), 2x1-12.7(16,19,20,22,24,28,34-36), 4x2-12.7(14),
		16	Shpil	1939		
		19	Gak	1939		
		20	Rym	1940		
		24	T-215	1940		
		28	Kontr-admiral	1941		

MSC						2dcr, 31mines, sweeps	
			Yurkovskiy				
		22	T-218	1940			
		34	Kontr-admiral Khoroshkhin	1944			
		35	T-220	1946			
		36	Dmitriy Lysov	1946			
	pr. 58	5	187	Paravan	1938		459t, 62.0x7.2x2.1m, 2d, 2900hp, 18.5kts, 47p; 1x1-100/56, 1x1-45/46(189,190), 4x1-37/73(255), 3x1-37/73(187-189), 4x1-12.7(187,188), 2x1-12.7(189,190,255), 2dcr, 31mines, sweeps
			188	Kapsiul	1939		
			189	Yakor	1939		
			190	Garpun	1939		
			255	Arseniy Rasskin	1941		
	MMS1	2	1	T-108	1942		295t, 36.4x7.1x2.7m, 1d, 375hp, 10kts, 20p; 1x1-20/70, 1x2-12.7, mechanical sweeps
			2	T-110	1942		
	MMS1001	12	1	T-121	1943		430t, 42.7x8.5x3.2m, 1d, 500hp, 10kts, 21p; 2x2-20/70, sweeps
			2	T-122	1942		
			3	T-193	1945		
			4	T-194	1945		
			5	T-195	1945		
			6	T-196	1945		
7			T-197	1945			
8			T-198	1945			
9			T-199	1946			
10			T-200	1946			
11			T-201	1946			
12			T-202	1946			
Viipuri	2	1	EMTShch-70	1941		335t, 31.6x7.5x4.0m, 1b,1vte, 368hp, 10kts; 2x1-45/46, 2x1-12.7, magnetic sweeps	
		2	EMTShch-72	1941			
		1	T-181	1944			
		2	T-182	1944			
		3	T-183	1944			
		4	T-184	1944			
		5	T-185	1944			
		6	T-186	1944			
		7	T-187	1944			
		8	T-188	1944			
		9	T-189	1944			

YMS

39

10	T-190	1944
11	T-191	1944
12	T-192	1944
13	T-521	1942
14	T-522	1943
15	T-524	1943
16	T-525	1945
17	T-526	1945
18	T-527	1943
19	T-588	1943
20	T-589	1942
21	T-590	1943
22	T-592	1942
23	T-593	1942
24	T-594	1943
25	T-595	1943
26	T-596	1943
27	T-598	1943
28	T-599	1943
29	T-600	1943
30	T-601	1943
31	T-602	1942
32	T-603	1942
33	T-604	1942
34	T-605	1943
35	T-606	1943
36	T-607	1943
37	T-608	1942
38	T-609	1943
39	T-611	1943



320t, 41.5x7.5x2.4m, 2d, 800hp, 14kts, 60p; 1x1-76/50, 2x1-20/70, 2dct, 2dcr, mechanical, magnetic, acoustic sweeps; SU radar, sonar

1	T-351	1943
2	T-352	1944
3	T-354	1944
4	T-356	1944
5	T-358	1944
6	T-359	1944
7	T-360	1944
8	T-361	1944
9	T-362	1944
10	T-363	1944
11	T-364	1944

pr. 253L
MT-1

25

12	T-370	1944
13	T-371	1944
14	T-372	1944
15	T-373	1944
16	T-374	1944
17	T-375	1944
18	T-376	1944
19	T-378	1944
20	T-380	1944
21	T-381	1944
22	T-382	1945
23	T-386	1944
24	T-388	1944
25	T-389	1944





127t, 38.0x5.7x1.4m, 3d, 690hp, 14kts, 21p; 2x1-45/69, 2x1-12.7, 2dcr, 12mines, sweeps; Tamir-10 sonar



MSI

1	T-222	1945
2	T-223	1945
3	T-224	1945
4	T-226	1945
5	T-227	1945
6	T-232	1945
7	T-233	1945
8	T-234	1945
9	T-235	1945
10	T-236	1945
11	T-237	1945
12	T-238	1945
13	T-239	1945
14	T-240	1945
15	T-242	1945
16	T-245	1945
17	T-247	1945
18	T-248	1945
19	T-249	1945
20	T-365	1945
21	T-366	1945
22	T-367	1945
23	T-368	1945
24	T-369	1945
25	T-383	1945
26	T-384	1945





pr. 253L





143t, 38.0x5.7x1.4m, 3d, 480hp, 12.5kts, 21p; 2x1-46/69, 2x2-12.7, 12mines, 2dcr,

MT-2	53	27	T-385	1945		sweeps; Tamir-10 sonar
		28	T-390	1944		
		29	T-391	1944		
		30	T-434	1945		
		31	T-435	1945		
		32	T-439	1945		
		33	T-440	1945		
		34	T-441	1945		
		35	T-459	1944		
		36	T-460	1944		
		37	T-461	1945		
		38	T-462	1945		
		39	T-463	1945		
		40	T-464	1945		
		41	T-466	1945		
		42	T-468	1945		
		43	T-469	1945		
		44	T-470	1945		
		45	T-471	1946		
		46	T-472	1945		
		47	T-473	1945		
		48	T-474	1945		
		49	T-475	1945		
		50	T-476	1945		
		51	T-477	1945		
		52	T-478	1945		
		53	T-479	1945		
pr. 255	10	1	T-310	1948		160t, 38.0x5.7x1.6m, 3d, 480hp, 10kts, 35p; 2x1-45/68, 2x1-12.7, 2dcr, mechanical, magnetic, acoustic sweeps; Tamir-10 sonar
		2	T-229	1948/49		
		3	T-230	1948/49		
		4	T-301	1948/49		
		5	T-302	1948/49		
		6	T-303	1948/49		
		7	T-304	1948/49		
		8	T-305	1948/49		
		9	T-306	1948/49		
		10	T-307	1948/49		
		1	KT-1265	1945		
		2	KT-1270	1945		
		3	KT-1282	1945		

MSB	KFK	18?	4	KT-i	1943/45		110t, 24.0x6.4x2.8m, 1d, 175hp, 9kts, 18p; 1x1-37/83, 2x1-20/65, 8dcr or sweeps					
			5	KT-ii	1943/45							
			6	KT-iii	1943/45							
			7	KT-iv	1943/45							
			8	KT-v	1943/45							
			9	KT-vi	1943/45							
			10	KT-vii	1943/45							
			11	KT-viii	1943/45							
			12	KT-ix	1943/45							
			13	KT-x	1943/45							
			14	KT-xi	1943/45							
			15	KT-xii	1943/45							
			16	KT-xiii	1943/45							
			17	KT-xiv	1943/45							
			18	KT-xv	1943/45							
				RA102	3				KT-i-iii	1943 - 1945		77-85t, 28.9-30.0x4.4-4.6x1.5m, 2d, 714hp, 14.6-15.5kts, 18p; 2x1-20/65, 6mines, sweeps
				RA204	1				KT-i	1943	No picture	35t, 25.0x4.5x1.4m, 14kts, 22p; 2x1-20/65, sweeps
			AMS	-	2			1	T-660			
2	T-680	1930					180t					











AMPHIBIOUS

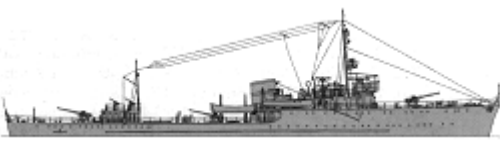

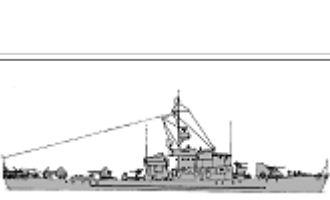

LSM	T101	1	1	DK-55	1944		1020t, 80.5x9.1x2.9m, 2b, 1gst, 2500hp, 16kts, 90p; 1x1-76/40, (4x3+9x1)-25/60; 14tanks or 320troops; 13-go radar
	MFP-A	7	1	DK-221	1942		220t, 47.0x6.5x1.5m, 3d, 390hp, 10.5kts, 21p; 1x1-75/35, 2x1-20/65; 2 tanks or 200 troops
			2	DK-332	1942		
			3	DK-333	1942		
			4	DK-334	1942		
			5	DK-380	1942		
			6	DK-383	1942		
			7	DK-399	1942		
	MFP-B	1	1	DK-393	1942		220t, 47.0x6.5x1.5m, 3d, 390hp, 10.5kts, 21p; 1x1-75/35, 2x1-20/65; 2 tanks or 200 troops
	MFP-C	3	1	DK-341	1942		220t, 47.0x6.5x1.5m, 3d, 390hp, 10.5kts, 21p; 1x1-75/35, 2x1-20/65; 2 tanks or 200 troops
			2	DK-403	1942		
			3	DK-404	1943		
			1	DK-82	1943		
			2	DK-4	1943		
			3	DK-83	1943		

LCU	MFP-D	17	4	DK-84	1943		239t, 49.8x6.6x1.4m, 3d, 375hp, 10.3kts, 21p; 1x1-75/35, 2x1-37/83, 4x1-20/65; 3tanks or 200troops					
			5	DK-7	1943							
			6	DK-29	1944							
			7	DK-327	1944							
			8	DK-346	1945							
			9	DK-369	1944							
			10	DK-378	1944							
			11	DK-407	1943							
			12	DK-408	1943							
			13	DK-409	1944							
			14	DK-412	1944							
			15	DK-413	1944							
			16	DK-414	1944							
			17	DK-415	1944							
			LCU	MFP-AM	4			1	DK-322	1942		240t, 47.0x8.3x1.5m, 3d, 390hp, 10kts, 21p; 1x1-75/35, 2x1-20/65, 52mines or 8LC
								2	DK-335	1942		
								3	DK-384	1942		
4	DK-392	1942										
LCU	MFP-C2M	2	1	DK-68	1943		240t, 47.0x8.4x1.5m, 3d, 390hp, 10kts, 21p; 1x1-75/35, 2x1-20/65, 52mines or 8LC					
			2	DK-337	1942							
LCU	MFP-DM	4	1	DK-430	1945		256t, 49.8x8.6x1.4m, 3d, 375hp, 8kts, 21p; 1x1-75/35, 2x1-37/83, 4x1-20/65, 54mines or 10LC					
			2	DK-27	1945							
			3	DK-28	1945							
			4	DK-40	1946							
LCU	LCI(L)	25	1	DK-104	1943		385t, 48.9x7.2x1.6m, 8d(2), 2320hp, 15.5kts, 29p; 5x1-20/70; 209troops; SO or SCR-517A radar					
			2	DK-105	1943							
			3	DK-106	1943							
			4	DK-107	1944							
			5	DK-91	1944							
			6	DK-92	1943							
			7	DK-93	1944							
			8	DK-31	1944							
			9	DK-32	1944							
			10	DK-33	1944							
			11	DK-34	1944							
			12	DK-35	1944							
			13	DK-36	1944							
			14	DK-37	1944							
			15	DK-38	1944							
			16	DK-39	1944							
			17	DK-40	1944							

			18	DK-41	1944				
			19	DK-42	1944				
			20	DK-44	1944				
			21	DK-45	1944				
			22	DK-94	1943				
			23	DK-95	1944				
			24	DK-96	1944				
			25	DK-50	1944				
	LCT(6)	11	1	DK-97	1944		320t, 36.3x10.0x1.2m, 3d, 675hp, 8kts, 13p; 2x1-20/70; 4tanks		
				2	DK-98			1944	
				3	DK-99			1944	
				4	DK-102			1944	
				5	DK-103			1944	
				6	DK-108			1944	
				7	DK-109			1944	
				8	DK-110			1944	
				9	DK-111			1944	
				10	DK-351			1944	
				11	DK-352			1944	
	LCT(5)	1	1	DK-81	1942		286t, 34.8x10.0x1.3m, 3d, 675hp, 8kts, 11p; 2x1-20/70; 4tanks		
	MZ780	2	1	DK-75	1943		279t, 46.5x6.5x1.0m, 3d, 450hp, 11kts, 13p; 1x1-76/40, 2x1-20/65; 200troops		
				2	DK-76			1943	
LCM	Siebel 41	1	1	DK-357	1941		130t, 24.3x13.7x1.2m, 2pe, 420hp, 6.6kts, 10p; 1x1-37/83, 2x1-20/65; 80t of cargo		
LCR	AFP-A	3	1	DK-11	1942		410t, 47.0x6.6x1.7m, 3d, 390hp, 9kts, 53p; 20shields, 20CT; 2x1-88/45, 1x1-37/83, 2x4-20/65, 1x1-15, 1dcr, 26mines		
			2	DK-160	1942				
			3	DK-371	1942				
		AFP-B	1	1	DK-304	1942		410t, 47.0x6.6x1.7m, 3d, 390hp, 9kts, 53p; 20shields, 20CT; 2x1-88/45, 1x1-37/83, 2x4-20/65, 1x1-15, 1dcr, 26mines	
		AFP-C	4	1	DK-1	1942		410t, 47.0x6.6x1.7m, 3d, 390hp, 9kts, 53p; 20shields, 20CT; 2x1-88/45, 1x1-37/83, 2x4-20/65, 1x1-15, 1dcr, 26mines	
					2	DK-15			1942
					3	DK-159			1942
					4	DK-400			1943
		AFP-D	5	1	DK-14	1943		440t, 49.8x6.6x1.7m, 3d, 375hp, 8kts, 65p; 40belt, 20shields, 20CT; 2x1-88/45, 1x1-37/83, 2x4-20/65, 1x1-15, 1dcr	
					2	DK-60			1947
					3	DK-80			1947
					4	DK-90			1947
					5	DK-100			1947

BOARD GUARD



PS	Kunitsa	1	1	Atarbekov	1916		273t, 39.2x5.8x2.4m, 2d, 1600hp, 14kts, 46p; 2x1-76/55, 2x1-12.7
	Barsuk	1	1	Mogilevskiy	1916		202t, 30.5x5.8x2.7m, 1b,1vte, 350hp, 11kts, 46p; 3x1-45/46, 2x1-12.7
	A32	1	1	Ametist	1916		250t, 50.0x5.3x2.1m, 1b,1gst, 3250hp, 25kts, 46p; 3x1-45/46, 3x1-12.7, 2dcr
	pr. 19	2	1	Dzerzhinskiy	1935		1161t, 80.0x8.3x3.8m, 3d, 4500hp, 18.5kts, 131p; 3x1-102/60, 4x1-45/46, 3x1-12.7, 2dct, 24mines
			2	Kirov	1935		
pr. 43	2	28	Rubin	1936		580t, 62.0x7.2x3.0m, 2d, 2200hp, 17.2kts, 61p; 1x1-102/60, 3x1-37/73, 6x1-12.7, 2dct, 31mines	
		30	Sapfir	1937			
APS	-	2	1	Vorovskiy	1901		2300t, 97.2x12.2x5.5m, 4b,2vte, 7000hp, 12kts, 140p; 2x1-102/60, 4x1-45/46, 2x1-12.7
			2	Uran	1908		247t
PC	pr. 122	1	1	Yakhont	1941		238t, 48.5x5.8x1.9m, 3d, 3300hp, 24kts, 49p; 1x1-76/55, 3x1-12.7, 2dcr; Tamir-1 sonar
	pr. 122A	5	143	BO-134	1944		250t, 50.4x5.8x2.1m, 3d, 3600hp, 21kts, 54p; 1x1-85/52, 2x1-37/73, 2x2-12.7, 2dct, 1dcr; Tamir-1 sonar
			150	BO-135	1944		
			151	BO-136	1944		
			162	BO-162	1946		
			168	BO-168	1948		
	pr. 122bis	4	441	BO-441	1948		325t, 51.7x6.6x2.2m, 3d, 3600hp, 20kts, 54p; 1x1-85/52, 2x1-37/73, 2x2-12.7, 2dct, 2dcr, 18mines; Giuys or Zarnitsa radar, Tamir-9 sonar
			444	BO-444	1948		
			452	BO-452	1949		
			453	BO-453	1949		
SC	1	1	BO-320	1943		136t, 33.8x5.5x2.0m, 2d, 2400hp, 21kts, 33p; 1x1-40/60, 3x1-20/70, 2x4-178 Mousetrap ASWRL, 2dct, 2dcr; SU radar, QC sonar	
K-1	5?		SK-610-614	1928	No picture	15t, 12.9x2.9x1.4m, 100hp, 8kts, 9p	
GK-1	2?		SK-134, 144	1930	No picture	20t, 22.5x3.9x1.1m, 2pe, 1000hp, 23kts, 13p; 1x1-12.7	
ZK	10?		SK-23, 33-36, 38-40, 43, 73	1931 -		19t, 19.8x3.3x1.2m, 2pe, 600hp, 16kts, 12p; 1x1-45/46	
K-229	1?		SK-93	1931	No picture	23t, 22.5x3.9x1.3m, 1700hp, 12kts; 1x1-12.7	
GK	1?		SK-47	1931		30t, 24.0x3.9x1.1m, 2pe, 1650hp, 23kts, 10p; 1x1-45/46	

PB	K-17	1?	SK-615	1931	No picture	17t, 18.9x3.6x1.4m, 600hp, 11kts, 9p
	K-164	1?	SK-164	1932	No picture	14t, 12.9x2.7x1.2m, 100hp, 9.9kts, 7p
	K-18	1?	SK-616	1932	No picture	14t, 13.6x2.8x1.7m, 300hp, 7kts
	BK-02	1?	MO-411	1934	No picture	75t, 26.9x4.0x1.9m, 3pe, 2550hp, 18kts, 20p; 2x1-45/46, 21-12.7, 2dcr, 4mines
	MO-1	1?	SK-132	1935		51t, 26.0x3.8x1.2m, 3pe, 1130hp, 14kts, 21p; 2x1-12.7, 2dcr
	MO-2	12?	MO-15, 56, 66, 75, 82, 109, 161, 171, 202, 261, 262, 413	1935 - 1940		50t, 26.2x3.9x1.5m, 3pe, 2250hp, 26kts, 21p; 2x1-45/46, 2x1-12.7, 2dcr
	MO-3	3?	MO-73, 301, 305	1935		55t, 26.2x4.0x1.2m, 3pe, 2065hp, 24kts, 21p; 2x1-45/46, 2x1-12.7, 2dcr
	PK-2	1?	SK-605	1936	No picture	15t, 15.3x2.9x1.4m, 300hp, 12kts, 12p
	MO-4	75?	MO-1-24, 26, 28-42, 44, 61-67, 65, 69, 72, 74, 77, 78, 102, 108, 203-205, 213, 233, 234, 251, 252, 306, 337-339, 347-349, 402, 403, 408, 409	1937 - 1945		57t, 26.9x4.0x1.5m, 2pe, 2000hp, 22kts, 21p; 2x1-45/68, 1x1-25/80, 2dcr
	MKM	5?	SK-50, 51, 67, 138, 335	1940	No picture	18t, 16.2x3.6x1.2m, 1pe, 850hp, 21kts, 10p
	BK	2?	SK-17, 27	1940 - 1941	No picture	20t, 17.6x3.9x1.3m, 2pe, 1650hp, 32kts, 10p; 2x1-12.7
	BKM-1	2?	SK-210, 609	1940 - 1942	No picture	38t, 21.7x4.0x1.1m, 280hp, 12.5kts, 12p

[home](#)[World navies yesterday](#)[1950](#)

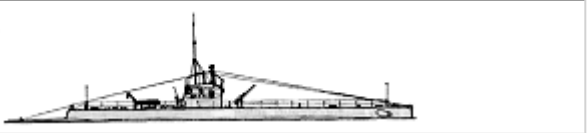
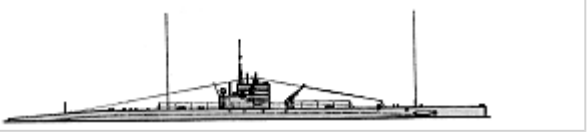
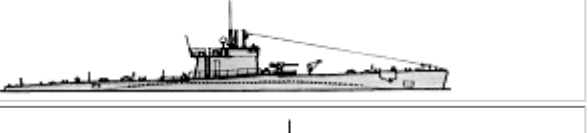
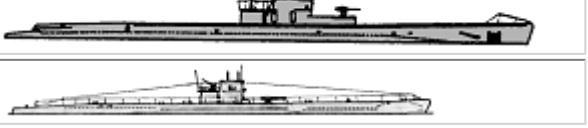

Spain 01 January 1950

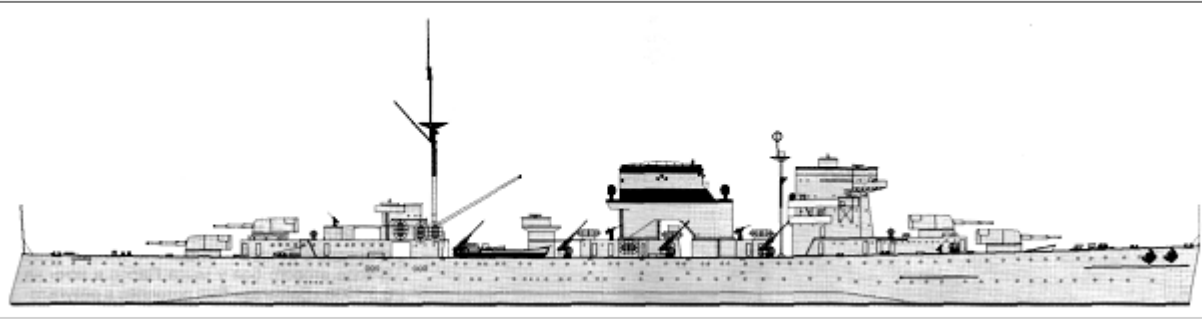
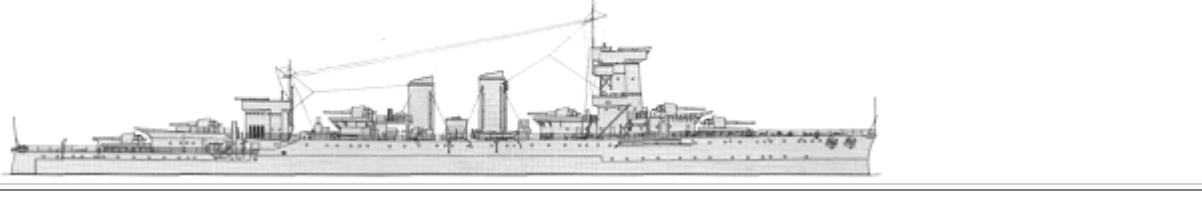

SUBMARINES

SS	B1	1	1	B2	1922		556/740t, 64.2x5.6x3.4m, 2d/em, 1400/420hp, 16.2/10.5kts, 28p, 60m; 1x1-76/45, 4-450TT
	C1	2	1	C1 Isaac Peral	1928		915/1143t, 75.3x6.3x4.1m, 2d/em, 2000/750hp, 16.5/8.5kts, 40p, 90m; 1x1-76/45, 6-533TT
			2	C2	1928		
	Archimede	2	1	General Mola	1934		970/1239t, 70.5x6.9x4.1m, 2d/em, 3000/1100hp, 17/8kts, 55p, 90m; 2x1-100/43, 2x1-13.2, 8-533TT
			2	General Sanjurjo	1934		
	D1	1	1	D1	1947		1065/1399t, 84.3x6.7x4.3m, 2d/em, 5000/1350hp, 20.5/9.5kts, 56p, 60m; 1x1-88/45, 1x1-20/65, 6-533TT
G1	1	1	G7	1941		769/1070t, 67.1x6.2x4.7m, 2d/em, 2800/750hp, 17/7.6kts, 54p, 100m; 1x1-88/45, 1x1-20/65, 5-533TT	

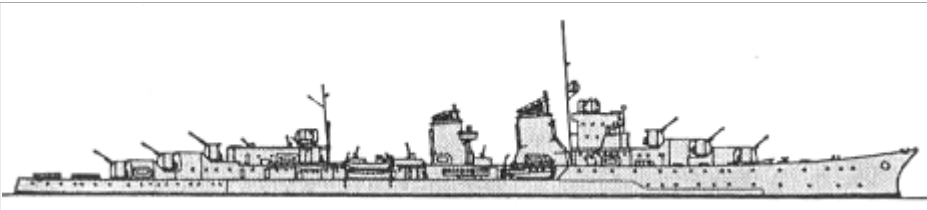
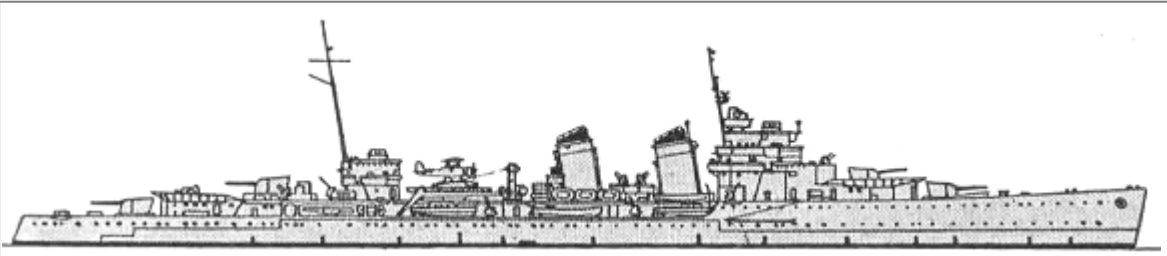
PRINCIPAL SURFACE COMBATANTS

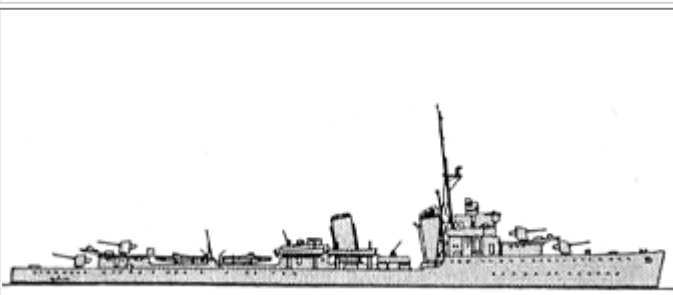
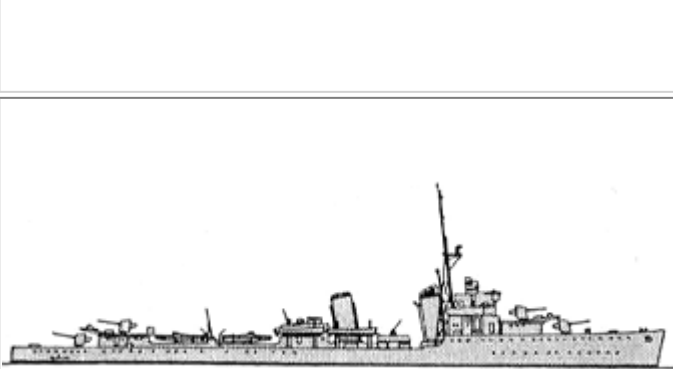
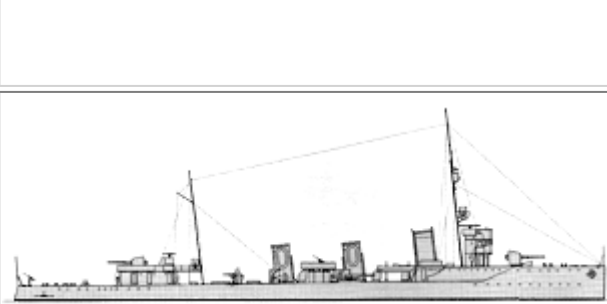

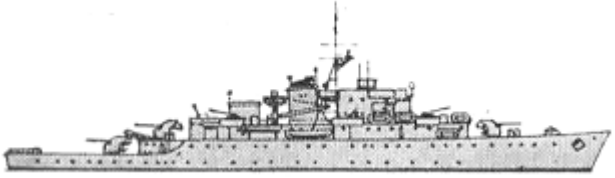
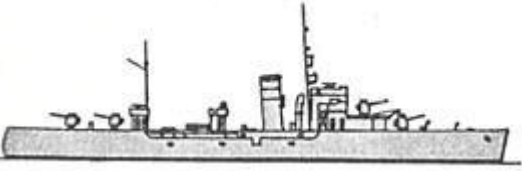
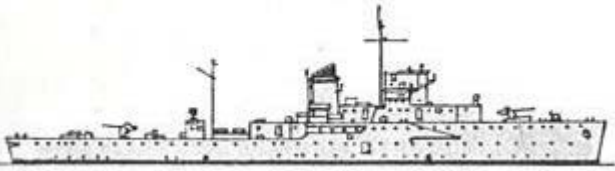
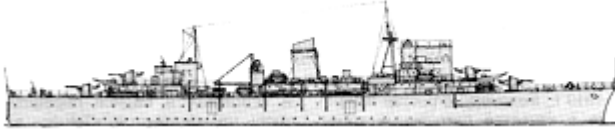

CA	Canarias	1	1	Canarias	1936		13750t, 193.6x19.5x5.3m, 8b,4gst, 90000hp, 33kts, 1200p; 51belt, 37deck, 25turrets, 25CT; 4x2-203/50, 8x1-120/45, 4x1-40/70, 4x2-37/83, 4x1-20/70, 2dct, 1dcr; SG-6B, MLA-1B, Marconi, Decca 12 radars
	Reina Victoria Eugenia	1	1	Navarra	1923		6450t, 140.8x15.2x4.8m, 8b,2st, 25500hp, 25kts, 404p; 50belt, 38deck, 152shields, 152CT; 6x1-152/50, 4x1-88/45, 4x4-20/65

CL	Méndez Núñez	1	1	Méndez Núñez	1924		6045t, 142.9x14.1x4.4m, 12b,4gst, 45000hp, 29kts, 343p; 76belt, 25deck, 150CT; 8x1-120/45, 5x2-37/83, 2x4-20/65, 2x3-533TT	
	Príncipe Alfonso	1	Galicia	1925			9748(1,3)-9660(2)t, 176.6x16.5x5.0m, 8b,4gst, 80000hp, 31.5(1,3)-33(2)kts, 781(1,3)-564(2)p; 76belt, 50deck, 13shields, 150CT; 4x2-152/50(1,3), (3x2+2x1)-152/50(2), 4x1-105/45(2), 8x2-37/83(1,3), 4x2-37/83(2), 5x4-20/65(1,3), 4x1-20/65(2), 2x3-533TT(1,3), 4x3-533TT(2), 4dct(1,3), 1seaplane(He114)(3)	
		2	Almirante Cervera	1927				
3		Miguel de Cervantes	1930					
Alsedo	3	1	Alsedo	1924			1337t, 86.8x8.2x4.5m, 4b,2gst, 33000hp, 34kts, 86p; 3x1-102/50, 3x1-20/65, 2x2-450TT, 2dct, 1dcr, 60mines	
		2	Velasco	1924				
		3	Lazaga	1925				
Churucca	6	1	Sánchez Barcáiztegui	1928			2087t, 102.0x9.7x3.2m, 4b,2gst, 42000hp, 36kts, 190p; 4x1-120/45, 2x2-37/83, 4x1-20/65, 2x3-533TT, 2dcr	
		2	José Luis Díez	1929				
		3	Lepanto	1930				
		4	Churucca	1931				
		5	Alcalá Galiano	1931				
		6	Almirante Valdés	1933				
DD	Almirante Antequera	7	1	Almirante Antequera	1935			2175t, 101.2x9.7x3.2m, 4b,2gst, 42000hp, 36kts, 190p; 4x1-120/45, 2x2-37/83, 4x1-20/65, 2x3-533TT, 2dct, 2dcr
			2	Almirante Miranda	1936			
			3	Gravina	1936			
			4	Escaño	1936			
			5	Císcar	1936			
			6	Jorge Juan	1937			
			7	Ulloa	1937			
Falco	1	1	Melilla	1917			1820t, 94.7x9.5x3.4m, 5b,2st, 40000hp, 34kts, 160p; 2x2-120/45, 2x1-76/40, 4x1-20/65, 2x2-450TT, 1dcr, 50mines	
Alessandro Poerio	1	1	Huesca	1915			1216t, 85.0x8.0x2.8m, 3b,2st, 20000hp, 31.5kts, 137p; 5x1-102/45, 1x1-40/39, 2x1-20/65, 2x1-13.2, 2x2-450TT, 42mines	

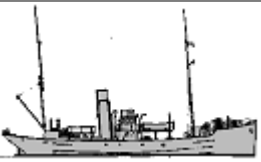
						
FF	Pizarro	1	Pizarro	1946		2246t, 95.2x12.2x3.4m, 2b,2gst, 6000hp, 18.5kts, 251p; 3x1-120/45(5,6), 3x1-105/45(1-3), 2x1-105/45(4), 4x2-37/83, 6x1-20/65, 4dct, 1dcr, 30mines
		2	Hernán Cortés	1947		
		3	Vasco Núñez de Balboa	1947		
		4	Martín Alonso Pinzón	1948		
		5	Magallanes	1948		
		6	Vicente Yáñez Pinzón	1949		
	Antonio Cánovas del Castillo	1	Cánovas del Castillo	1923		1335t, 77.3x10.2x3.4m, 2b,2vte, 1700hp, 15kts, 132p; 4x1-102/45, 2x1-47/50, 3x1-20/65
		2	Canalejas	1924		
		3	Dato	1925		
	Calvo Sotelo	1	Calvo Sotelo	1938		2000t, 92.4x12.2x3.5m, 2b,2gst, 6500hp, 18.5kts, 160p; 2x1-102/45, 2x1-57/42, 3x1-20/65, 2dcr
	Júpiter	1	Marte	1938		2600t, 96.0x12.7x3.5m, 4b,2gst, 10000hp, 18.5kts, 180p; 4x1-120/45, 2x1-76/40, 3x1-20/65, 264mines, 2dcr
		2	Neptuno	1939		
3		Júpiter	1937			
4		Vulcano	1937			
Eolo	1	Eolo	1941		1925t, 88.9x11.8x3.7m, 2b,2gst, 5000hp, 19.5kts, 220p; 4x1-105/44, 2x2-37/83, 4x1-20/65, 2dct, 70mines	
	2	Tritón	1943			

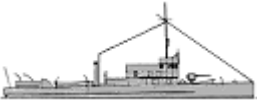
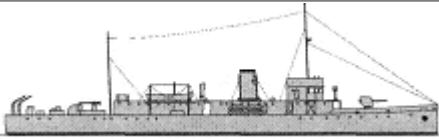
PATROL AND COASTAL COMBATANTS

Castle	2	1	Uad Martin	1917		547t, 40.8x7.2x2.8m, 1b,1vte, 480hp, 10.5kts, 39p; 1x1-76/50
		2	Alhucemas	1918		
		1	Uad Kert	1917		
		2	Arcíla	1918		

PC	Mersey	3					665t, 45.1x7.2x2.8m, 1b,1vte, 600hp, 11kts, 45p; 1x1-76/50(1,3), 2x1-76/50(2), 1x1-47/50(3)
			3	Xauen	1918		
	Briscard	2	1	Alcázar	1918		440t, 41.0x7.3x3.2m, 1b,1vte, 425hp, 11kts, 41p; 1x1-76/50, 1x1-57/42(2), 2x1-47/50(1)
			2	Tetuán	1918		
Lanzón	2	1	V17	1935	No picture	111t, 26.5x5.4x3.1m, 1pe, 285hp, 12kts	
		2	V18	1935			
Hunt	1	1	Virgen de la Caridad	1919		1094t, 70.4x8.8x2.9m, 2b,2vte, 1600hp, 13.2kts, 97p; 3x1-102/45, 2x1-20/65	
APC	-	1	1	Finisterre	1894		365t
PR	Cabo Fradera	1	1	Cabo Fradera	1928		45t, 22.8x4.4x1.2m, 2pe, 121hp, 10.7kts, 16p; 1x1-42/42
PT	LT21	6	1	LT21	1943		115t, 34.9x5.3x1.7m, 3d, 7500(21,22,25,26)-6000(23,24)hp, 41(21,22,25,26)-39(23,24)kts, 24p; 2x1-20/65, 2-533TT, 2dcr, 6mines
			2	LT22	1943		
			3	LT23	1942		
			4	LT24	1942		
			5	LT25	1943		
			6	LT26	1943		
PB	V20	2	1, 2	V20, 21	1942 - 1944		60t, 26.2x4.7x1.4m, 2d, 700hp, 18kts, 14p; 2x1-20/65
	C.I	18	1-18	C1, 3, 4, 6-16, 18-21	1922 - 1925	No picture	36t, 22.8x4.0x1.4m, 2d, 180hp, 12kts, 6p
	I1	5	1	MNF525	1923	No picture	128t, 33.5x2.6x1.8m, 2d, 600hp, 13kts; 1x1-57/42
			2	I2	1923		
			3	I3	1923		
4			I4	1923			
			5	I6	1923		

AMPHIBIOUS

LCU	LCT(4)	2	1	Foca	1944		640t, 57.1x11.8x1.4m, 2d, 920hp, 10kts, 12p; 2x1-20/70, 9tanks or 200troops
			2	Morsa	1945		

MINE WARFARE

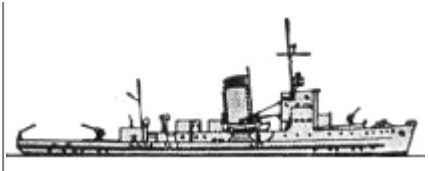

MSO	Bidasoa	7	1	Bidasoa	1946		748t, 61.9x8.5x2.6m, 2b,2vte, 2400hp, 16.5kts, 90p; 1x1-88/45 or 1x1-102/45, 1x1-37/83, 2x1-20/65, 2dcr, sweeps
			2	Nervión	1946		
			3	Lérez	1947		
			4	Tambre	1946		

5	Guadalete	1946
6	Segura	1949
7	Ter	1948



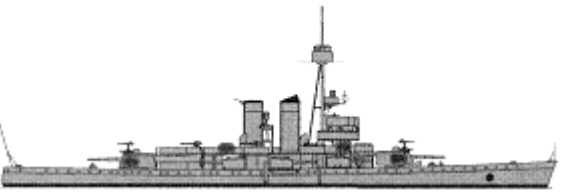
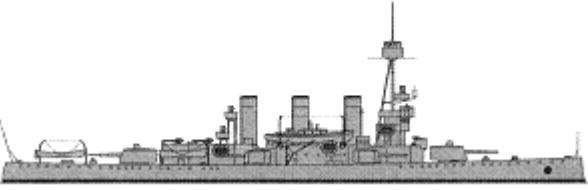
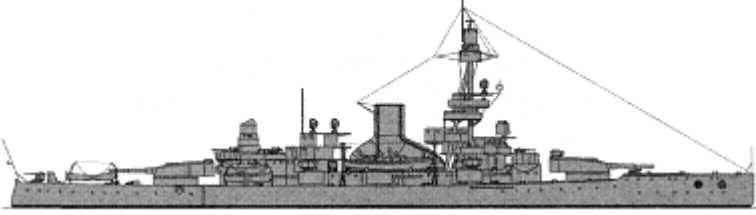
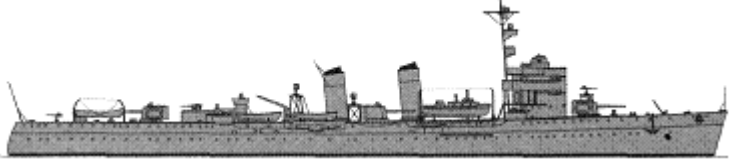
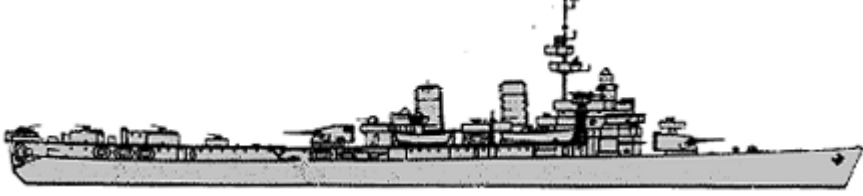
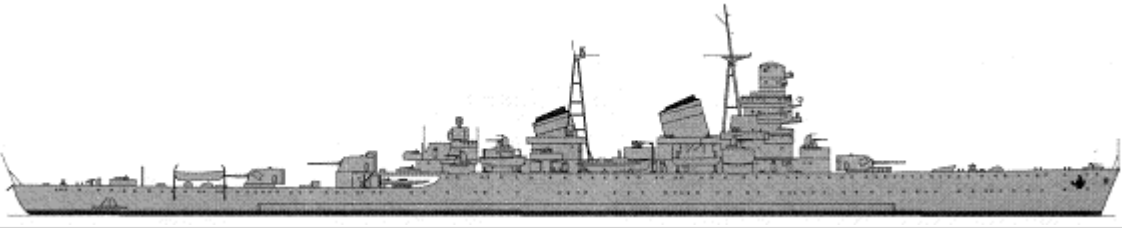
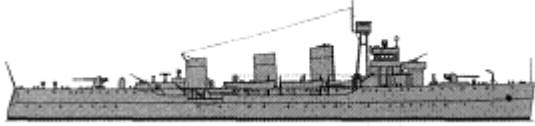
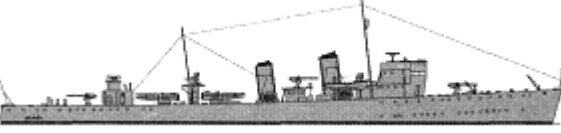

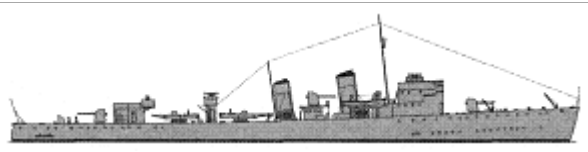
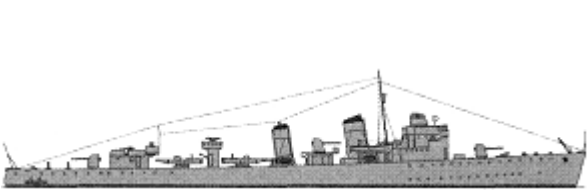
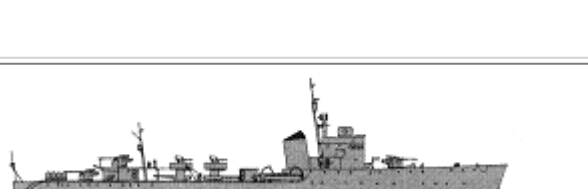

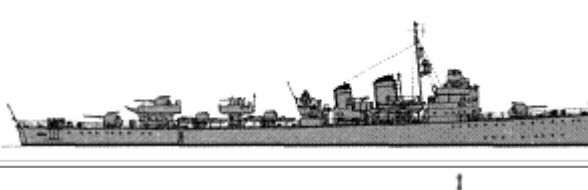
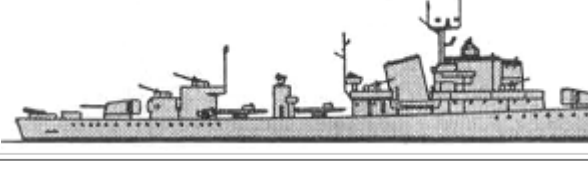
© Ivan Gogin, 2015

						4x1-40/60, 2x1-37/37, 2x1-25/58, 2-450TT	
BC	Oscar II	1	1	Oscar II	1907		4850t, 95.6x15.4x5.5m, 10b,2vte, 9400hp, 18kts, 331p; 150belt, 50deck, 190turrets, 157CT; 2x1-209/44, 4x2-152/50, 2x2-75/60, 3x1-37/37, 1x2-25/58
	Sverige	1	Sverige	1917		7516(1)-7633(2,3)t, 120.0(1)-121.6(2,3)x18.6x6.3m, 4b,2gst(1)-8b,2gst(2,3), 23910hp, 22.5kts, 427p; 200belt, 45deck, 200turrets, 175CT; 2x2-283/45, (1x2+4x1)-152/50(2), 6x1-152/50(1,3), 2x2-75/60, 2x1-57/55, 3x2-40/60, 2x2-20/66(1), 7x1-20/66(2), (2x2+4x1)-20/66(3); radar	
		2	Drottning Victoria	1921			
		3	Gustaf V	1922			
CA	Fylgia	1	1	Fylgia	1907		4980t, 117.3x14.8x6.1m, 4b,2vte, 13000hp, 23.5kts, 322p; 100belt, 35deck, 125turrets, 100CT; 4x2-152/50, 4x1-57/55, 2x2-40/60, 1x2-25/58, 1x1-20/66, 2x1-533TT, 2dcr
CL	Gotland	1	1	Gotland	1934		5550t, 134.8x15.4x4.5m, 4b,2gst, 33000hp, 27.5kts, 480p; 24belt, 25deck, 25turrets, 19CT; (2x2+2x1)-152/55, (1x2+2x1)-75/60, 4x2-40/60, (1x2+4x1)-25/58, 2x2-20/66, 2x3-533TT, 100mines; radar
	Tre Kronor	2	2	Tre Kronor	1947		9238t, 180.2x16.7x5.7m, 4b,2gst, 90000hp, 33kts, 783p; 90belt, 60decks, 125turrets, 20CT; (1x3+2x2)-152/53, 10x2-40/60, 7x1-20/66, 2x3-533TT, 120mines, 4dcr; radar
CM	Clas Fleming	1	1	Clas Fleming	1914		1850t, 86.0x10.4x4.3m, 2b/4dgg,2gst/gt, 7200hp, 20.3kts, 160p; 25deck, 75CT; 4x1-120/50, 3x1-40/60, 3x1-25/58, 200mines, 2dcr
	Ehrensköld	11	Ehrensköld	1927		1160t, 91.4x8.9x3.8m, 3b,2gst, 24000hp, 36kts, 120p; 3x1-120/45, 2x2-25/58, 2x3-533TT, 2dct, 2dcr, 20mines	
		12	Nordenskjöld	1927			
	Klas Horn	1	3	Klas Horn	1932	1190t, 92.4x8.9x3.7m, 3b,2gst, 26000hp, 37kts, 119p; 3x1-120/45, 2x2-25/58, 2x3-533TT, 2dct, 2dcr, 20mines	

DD	Göteborg	6	5	Göteborg	1936		1184t, 94.6x9.0x3.8m, 3b,2gst, 32000hp, 39kts, 155p; 3x1-120/45, 2x2-25/58(5,6), 3x2-25/58(7-10), 2x3-533TT, 2dct, 2dcr, 20mines
			6	Stockholm	1937		
			7	Malmö	1939		
			8	Karlskrona	1940		
			9	Gävle	1941		
			10	Norrköping	1941		
	Spica	2	27	Romulus	1935		995t, 80.4x8.2x3.1m, 2b,2gst, 19000hp, 34kts, 94p; 3x1-100/47, 3x2-20/65, 2x2-450TT, 2dct, 20mines
			28	Remus	1935		
	Mode	4	29	Mode	1942		960t, 78.0x8.1x2.3m, 2b,2gst, 16000hp, 31kts, 100p; 3x1-105/50, 2x1-40/60, 2x1-20/66, 1x3-533TT, 2dct, 42mines
			30	Magne	1942		
			31	Munin	1943		
			32	Mjölner	1942		
	Visby	4	11	Visby	1943		1320t, 98.0x9.0x3.8m, 3b,2gst, 32000hp, 39kts, 155p; 3x1-120/45, (1x2+2x1)-40/60, 4x1-20/66, 2x3-533TT, 2dct, 2dcr, 46mines
			12	Sundsvall	1943		
			13	Hälsingborg	1943		
			14	Kalmar	1944		
	Öland	2	16	Öland	1947		2250t, 112.0x11.2x3.4m, 2b,2gst, 44000hp, 35kts, 210p; 2x2-120/45, 7x1-40/60, 8x1-20/66, 2x3-533TT, 2dct, 2dcr, 40mines
			17	Uppland	1948		
	FS	Jägaren	4	41	Jägaren	1934	
42				Kaparen	1934		
43				Snapphanen	1936		
44				Väktaren	1935		

PATROL AND COASTAL COMBATANTS



PC	-	6	J21	Granat	1935		440t, 1vte, 800hp, 10kts; 1x1-57/55
			J22	Harpun	1925		440t, 1vte, 800hp, 10kts; 1x1-57/55
			J71	Kanon	1924		300t, 1vte, 700hp, 10kts; 1x1-57/55
			J72	Krut	1924		300t, 1vte, 700hp, 10kts; 1x1-57/55
			1	Styrbjörn	1923		350t, 1vte, 800hp, 10kts; 1x1-57/55
			2	Starkodder	1925		357t, 1vte, 800hp, 10kts; 1x1-57/55
PT	T15	4	T15-18	1941		23t, 18.7x4.6x1.5m, 2pe, 2300hp, 45kts, 11p; 1x1-20/66, 2-450TT	
	T21	11	T21-31	1942-1943		27t, 20.0x5.0x1.5m, 2pe, 3000hp, 49kts, 11p; 1x1-20/66, 2-533TT	

PB	Asköfjärd	3	V71-73	Asköfjärd, Baggensfjärd, Nämdöfjärd	1931-1932	No picture	25t, 19.3x3.8x1.5m, 1d, 92hp, 11.5kts, 7p; 1x1-37/39
	Kanholmsfjärd	3	V74-76	Kanholmsfjärd, Lidöfjärd, Edöfjärd	1933	No picture	28t, 21.2x3.8x1.5m, 1d, 92hp, 11.5kts, 7p; 1x1-37/39
	SVK1	5	SVK1-5		1944	No picture	19t, 16.5x3.7x1.2m, 1d, 100hp, 10.5kts, 12p; 1x1-20/66
	V51	6	V51		1944		145t, 32.0x5.3x2.2m, 1b,1vte, 400hp, 11kts, 12p; 1x1-20/66
			V52		1945		
			V53		1945		
			V54		1945		
V55				1944			
V56		1945					

AMPHIBIOUS

LCM	Ane	4	J324	Ane	1943	No picture	135t, 28.0x8.0x1.8m, 2d, 8.5kts; 1x1-20/66; troops
			J325	Balder	1943		
			J326	Loke	1943		
			J327	Ring	1945		
	L1	15	L1-15		1949	No picture	30t, 14.4x4.8xm, d, 8kts; troops

MINE WARFARE

ML	Mul3	1	Mul3	Mul3	1879	No picture	190t, 6.5kts; mines
	Mul5	4	Mul5	Mul5	1904	No picture	120t, 7.5kts; mines
			Mul6	Mul6	1904		
			Mul7	Mul7	1904		
			Mul8	Mul8	1905		
	Mul9	1	Mul9	Mul9	1912	No picture	120t, 9.1kts; mines
	Mul10	1	Mul10	Mul10	1939	No picture	166t, 27.4x5.6x2.3m, 9.5kts; mines
Älvsrabben	1	M01	Älvsrabben	1943		4250t, 102.0x13.6x4.9m, 1d, 3000hp, 14kts, 255p; 4x1-152/44, 4x2-40/60, 6x1-20/66, 4dcr, 380mines	
Mul11	1	Mul11	Mul11	1946	No picture	200t, 30.1x7.2x3.6m, 2d(1), 300hp, 10kts, 9p; 2x1-20/66, mines	
MSC	Arholma	14	53	Arholma	1939		442t, 56.7x7.6x2.1m, 2b,2gst, 3200hp, 17kts, 37p; 2x1-105/41, 2x1-40/60, 2dct, mines, sweeps
			54	Landsort	1939		
			55	Bremön	1940		
			56	Holmön	1940		
			57	Sandön	1941		
			58	Ulvön	1941		
			59	Bredskär	1941		
60	Grönskär	1941					
61	Ramskär	1941					

			62	Örskär	1941		
			63	Koster	1940		
			64	Kullen	1941		
			65	Vinga	1940		
			66	Ven	1941		
MSI	M1	2	M1, 2		1938	No picture	62t, 30.0x4.3x1.0m, 3hbe(1)-3d(2), 600(1)-630(2)hp, 16.5(1)-18(2)kts, 11p; 1x1-13.2, dc, sweeps
	M3	12	M3-14		1940-1941	No picture	50t, 25.0x5.1x1.4m, 2d, 400hp, 13kts; 1x1-20/66, sweeps
	M15	12	M15-26		1941-1942		70t, 27.7x5.0x1.5m, 2d, 410hp, 13kts; 1x1-20/66, sweeps
	Orust	2	M41	Orust	1948	No picture	110t, 19.0x6.0x1.5m, 1d, 210hp, 9kts, 10p; 2x1-25/58, sweeps
M42			Tjörn	1949			

© Ivan Gogin, 2015

[home](#)

[World navies yesterday](#)

[1950](#)

Syria 01 January 1950

PATROL AND COASTAL COMBATANTS



PB	Ch5	3	1	Akba Ben Naseh	1940		137t, 37.1x5.7x2.0m, 2d, 1130hp, 15.5kts, 28p; 2x1-20/70, 4dct, 1dcr
			2	Tarek Ben Said	1940		
			3	Abdullah Ibn Arissi	1946		

© Ivan Gogin, 2016

[home](#)[World navies yesterday](#)[1950](#)



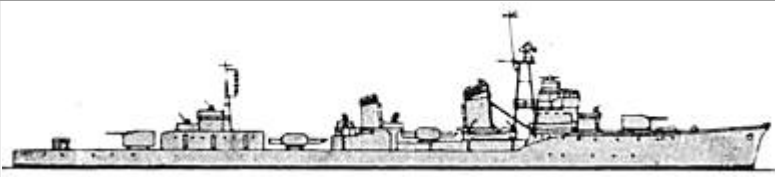
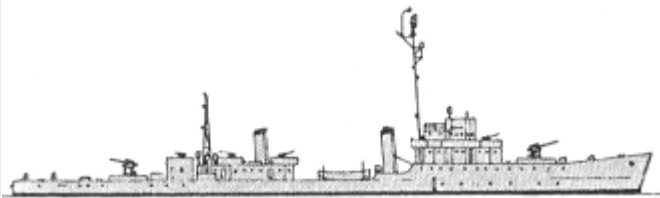

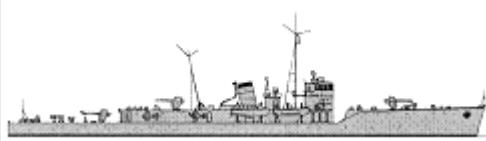
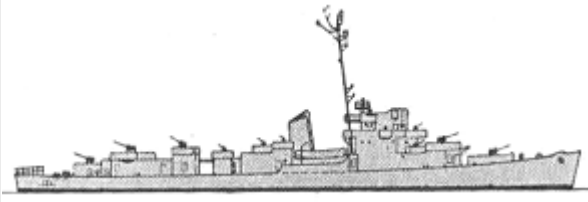
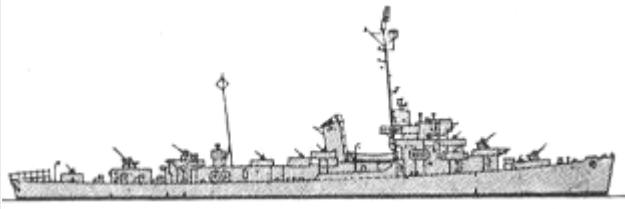
Taiwan 01 January 1950

PRINCIPAL SURFACE COMBATANTS

DD	Kagero	1	DD12	Tanyang	1940		2600t, 118.5x10.8x3.8m, 3b,2gst, 52000hp, 35kts, 240p; 2x2-127/40, 4x1-100/65, (4x3+1x2+14x1)-20/65, 2x4-610TT, 4dct
FF	Tachibana	1	DD15	Hsinyang	1945		1640t, 100.0x9.4x3.4m, 2b,2gst, 19000hp, 27.8kts, 211p; (1x2+1x1)-127/40, (4x3+17x1)-25/60, 1x4-610TT, 7dct, 2dcr; 13-go, 22-go radars
	Matsu	1	1	Huiyang	1944		1650t, 100.0x9.4x3.3m, 2b,2gst, 19000hp, 27.8kts, 211p; (1x2+1x1)-127/40, (4x3+17x1)-25/60, 1x4-610TT, 7dct, 2dcr; 13-go, 22-go radars
	Etorofu	1	PF77	Lingan	1943		1020t, 77.7x9.1x3.1m, 2d, 4200hp, 19.7kts, 147p; 3x1-120/45, 5x3-25/60, 1x1-81/12 ASWM, 6dct; 22-go radar
	Evarts	2	DE21	Taikang	1943		1416t, 88.7x10.7x3.1m, 4dg,2em, 6000hp, 19.5kts, 156p; 4x1-76/50, 1x2-40/60, 10x1-20/70, 8dct, 2dcr; SA, SF radars, sonar
			DE22	Taiping	1943		
	Cannon	4	DE23	Taiho	1943		1602t, 93.3x11.2x3.2m, 4dg,2em, 6000hp, 21kts, 186p; 4x1-76/50, 2x2-40/60, 11x1-20/70, 8dct, 2dcr; SA, SF radars, sonar
			DE24	Taihu	1943		
		DE25	Taitsang	1943			
		DE26	Taichao	1944			
Ihsien	1	FF78	Ihsien	1930		1650t, 83.8x10.5x3.4m, 3b,2vte, 4000hp, 16kts, 173p; 3x1-76/40, 2x2-13.2	

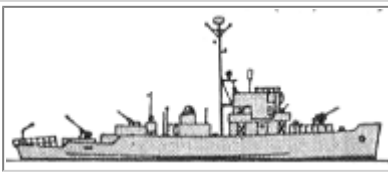

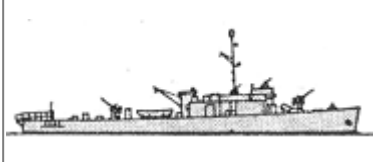
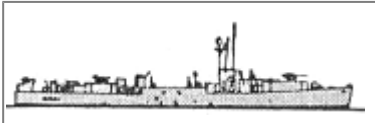

							
FS	D	3	PF71	Taian	1945		940t, 69.5x8.6x3.1m, 2b,1gst, 2500hp, 17.5kts, 160p; 2x1-120/45, (2x3+2x2+4x1)-25/60, 1x1-81/12 ASWM, 12dct; 13-go, 22-go radars
			PF72	Chengan	1944		
			3	Tongan	1945		
	C	4	PF74	Chaoan	1946		810t, 67.5x8.4x2.9m, 2d, 1900hp, 16.5kts, 136p; 2x1-120/45, (2x3+2x2+4x1)-25/60, 1x1-81/12 ASWM, 12dct; 13-go, 22-go radars
			PF75	Sinan	1944		
			3	Yingkou	1944		
			4	Liaohai	1944		
	Mikura	1	PF76	Taiwan	1944		1020t, 78.8x9.1x3.1m, 2d, 4200hp, 19.5kts, 150p; (1x2+1x1)-120/45, (3x2+7x1)-25/60, 1x1-81/12 ASWM, 12dct; 22-go radar

PATROL AND COASTAL COMBATANTS

PS	PCE	2	PCE41	Yungtai	1943		903t, 56.2x10.1x2.9m, 2d, 2000hp, 15.1kts, 96p; 1x1-76/50, 2x2-40/60, 2x1-20/70, 1x24-178 Hedgehog ASWRL, 4dct, 2dcr; SF radar, sonar
			PCE42	Yongxing	1943		
PC	Ch28	1	PC106	Yanglung	1944		442t, 51.0x6.7x2.6m, 2d, 1700hp, 16kts, 80p; 1x1-76/40, 1x3-25/60, 2x1-13.2, 2dcr
	Ch4	1	1	Fuling	1939		309t, 56.2x5.6x2.2m, 2d, 2600hp, 20kts, 59p; 1x2-40/62, 1x3-25/60, 2dct
	PC 173ft	4	1	Wusong	1942		463t, 52.9x7.1x3.3m, 2d, 2880hp, 19kts, 65p; 1x1-76/50, 1x1-40/60, 4x1-20/70, 2x4-178 Mousetrap ASWRL, 2dct, 2dcr; radar, sonar
			2	Qiantang	1944		
			PC104	Tuojiang	1943		
			PC105	Huangpu	1942		
	PGM 173ft	3	PC101	Baoying	1944		463t, 52.9x7.1x3.3m, 2d, 2880hp, 19kts, 65p; 1x1-76/50, 1x2-40/60, 6x1-20/70, 1x2-60/12 mortar, 2x1-12.7; radar
			PC102	Dongting	1945		
			PC103	Hongze	1945		
	HDML	8	1-8	Fang 1-8	1941-1944		54t, 22.0x4.8x1.4m, 2d, 300hp, 11.8kts, 10p; 2x1-20/70, 2dcr
			SC101	Chuchien 101	1942		
			SC102	Chuchien 102	1942		
			SC103	Chuchien	1942		

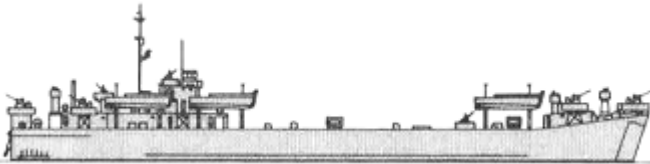
PB	SC	9		103			136t, 33.8x5.5x2.0m, 2d, 1000hp, 16kts, 27p; 1x1-40/60, 3x1-20/70, 2x4-178 Mousetrap ASWRL, 2dct, 2dcr; radar, QC sonar
			4		1942		
			5		1942		
			6		1943		
			7		1942		
			8		1942		
			9		1943		

AMPHIBIOUS

LST	LST(2)	10	LST201	Zhonghai	1944		4080t, 1000x15.2x4.3m, 2d, 1800hp, 12.1kts, 125p; (2x2+6x1)-40/60, 12x1-20/70; 4 LCVP, 20tanks, 163troops; SO radar
			LST203	Zhongding	1944		
			LST204	Zhongxing	1944		
			LST205	Zhongjian	1944		
			LST206	Zhongji	1944		
			LST207	Zhongcheng	1945		
			LST208	Zhongxun	1944		
			LST209	Zhonglian	1945		
			LST210	Zhongrong	1944		
			LST211	Zhongsheng	1944		
LSM	LSM1	10	LSM341	Meizhen	1944		1095t, 62.0x10.5x2.1m, 2d, 2800hp, 13kts, 60p; 1x2-40/60, 4x1-20/70; 5tanks, 54troops; SO radar
			LSM342	Meile	1944		
			LSM343	Meiyi	1944		
			LSM344	Meipeng	1945		
			LSM345	Meiheng	1945		
			LSM346	Meihong	1945		
			LSM347	Meisong	1945		
			LSM348	Meihe	1944		
			LSM349	Meijian	1944		
			LSM350	Meihua	1944		
LSS	LCI(L)	5	LCI261	Lianzhu	1943		385t, 48.9x7.2x1.6m, 8d(2), 2320hp, 15.5kts, 29p; 5x1-20/70; 209troops; SO radar
			LCI262	Lianli	1944		
			LCI263	Lianshen	1944		
			LCI264	Lianhua	1944		
			LCI265	Lianzhen	1944		
LSS	LCT(6)	6	LCU481	Hequn	1944		320t, 36.3x10.0x1.2m, 3d, 675hp, 8kts, 13p; 2x1-20/70; 4tanks
			LCU482	Hezhong	1944		
			LCU483	Hecheng	1944		
			LCU484	Hezhong	1944		
			LCU485	Hezhang	1943		
			LCU486	Hezhen	1944		

LC	LCVP	6	1-6		1943-1945		13t, 11.2x3.2x0.9m, 2d, 220hp, 8kts, 3p; 2x1-12.7; 36troops
----	------	---	-----	--	-----------	--	---

MINE WARFARE

ML	Sokuten	1	29	Jieh 29	1915		435t, 45.7x7.6x2.3m, 1b,1vte, 600hp, 12.8kts, 40p; 2x1-76/40, 2x1-13.2, 4dct, 120mines, mechanical minesweeping gear
	Lepanto	1	1	Xianning	1927		850t, 62.2x8.7x2.6m, 2b,2vte, 1500hp, 15kts, 184p; 1x1-76/40, 4x2-25/60, 2dct, 2dcr
	Hirashima	1	PF75	Yongjing	1942		750t, 75.5x7.9x2.6m, 2d, 3500hp, 20kts, 100p; 1x1-76/40, 2x3-25/60, 4dct, 120mines
MSO	Admirable	12	MSF43	Yongsheng	1943		945t, 56.2x10.1x3.0m, 2d, 2000hp, 15.1kts, 96p; 1x1-76/50, 2x2-40/60, mechanical, acoustic, magnetic minesweeping gear; radar
			MSF44	Yongshun	1943		
			MSF45	Yongding	1943		
			MSF46	Yongning	1944		
			MSF47	Yongjia	1944		
			MSF48	Yongxiu	1944		
			MSF49	Yongshou	1944		
			MSF50	Yongfeng	1944		
			MSF51	Yongchang	1945		
			MSF52	Yongchun	1945		
			MSF53	Yonghe	1944		
			MSF54	Yongkang	1945		





[home](#)[World navies yesterday](#)[1950](#)

Thailand 01 January 1950

SUBMARINES

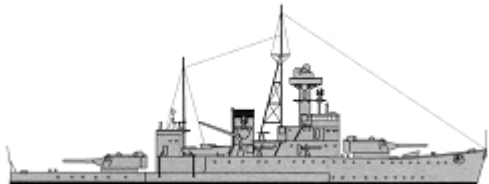

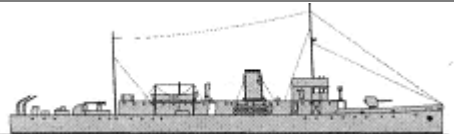

SS	Vilun	4	1	Vilun	1937		370/430t, 51.0x4.1x3.7m, 2d/em, 1000/540hp, 14.5/8kts, 24p, 60m; 1x1-76/40, 1x1-13.2, 5-533TT
			2	Machanu	1937		
			3	Sinsumudar	1938		
			4	Blajunbol	1938		

PRINCIPAL SURFACE COMBATANTS

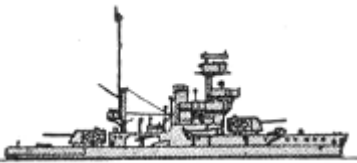

BC	Sri Ayuthia	1	1	Sri Ayuthia	1938		2265t, 76.5x14.4x4.2m, 2d, 5200hp, 15.5kts, 155p; 63belt, 63decks, 102turrets, 102CT; 2x2-203/50, 4x1-76/40, 4x1-40/62
DD	R	1	1	Phra Ruang	1917		1208t, 83.6x8.3x2.7m, 3b,2gst, 27000hp, 36kts, 82p; 3x1-102/40, 1x1-76/40, 1x1-40/39, 2x1-20/70, 2x2-533TT
FF	Tachin	1	1	Meklong	1937		2000t, 82.0x10.4x3.1m, 2b,2vte, 2500hp, 17kts, 155p; 4x1-120/45, 2x1-20/65, 2x2-450TT, mines, sweeps, 1seaplane (WS-103)
FS	Trad	7	11	Trad	1936		470t, 68.0x6.4x2.1m, 2b,2gst, 9000hp, 31kts, 70p; 3x1-76/40, 2x1-20/65, (2x2+2x1)-450TT
			12	Puket	1936		
			13	Patani	1938		
			21	Surasdra	1938		
			22	Chandraburi	1938		
			23	Rayong	1938		
			31	Chunphorn	1938		
	Hunt	1	1	Chao Phraya	1919		840t, 70.4x8.7x2.2m, 2b,2vte, 2200hp, 16kts, 65p; 2x1-76/40, 1x1-40/39

Flower mod.	2	4	Bangpakong	1943		1370t, 62.5x10.1x4.4m, 2b,1vte, 2750hp, 16.5kts, 109p; 1x1-102/45, (1x2+2x1)-20/70, 1x24-178 Hedgehog ASWRL, 4dct, 2dcr; type 276, 291 radars, sonar
		3	Prasae	1943		

PATROL AND COASTAL COMBATANTS

PS	Ratanakosindra	2	1	Ratanakosindra	1925		1000t, 53.0x11.3x3.3m, 2b,2vte, 850hp, 12kts, 102p; 2x1-152/50, 4x1-76/40, 4x1-40/39
			2	Sukhotai	1930		
PC	PC 173'	5	1	Sarasin	1942		463t, 52.9x7.1x3.3m, 2d, 2880hp, 19kts, 65p; 1x1-76/50, 1x1-40/60, 5x1-20/70, 2x4-178 Mousetrap ASWRL, 2dct, 2dcr; SO radar, QCU-2 sonar
			2	Thayanchon	1942		
			3	Khamronsin	1942		
			4	Phali	1944		
			5	Sukrip	1944		
PT	Klongyai	3	5	Klongyai	1937		135t, 42.0x4.6x1.5m, 2b,2gst, 1000hp, 19kts, 31p; 1x1-76/40, 2x1-20/65, 1x2-450TT
			6	Takbai	1937		
			7	Kantang	1937		
	No6	12	6-17		1935-1937		16t, 16.8x3.4x1.2m, 2pe/1pe, 950/30hp, 40kts, 5p; 2-450TT, 2dcr
PB	Sarasin	3	1	Sarasin	1935		50t, 21.9x3.9x1.0m, 2d, 150hp, 9kts; 1x1-37/20
			2	Thiew Uthock	1936		
			3	Travane Vari	1936		
	No1	6	1-6		1945-1948	No picture	16t, 12.5kts; 1x1-20/70

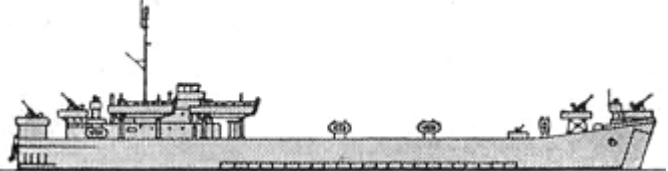
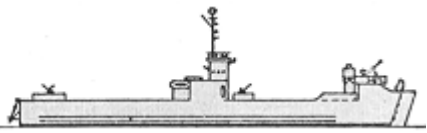
AMPHIBIOUS

LST	LST1	1	1	Angthong	1944		4080t, 100.0x15.2x4.3m, 2d, 1800hp, 12.1kts, 125p; (1x2+5x1)-40/60, 12x1-20/70; 20tanks, 163troops; SO-8 radar
LSM	LSM1	2	1	Kut	1944		1095t, 62.0x10.5x2.1m, 2d, 2800hp, 13kts, 60p; 1x2-40/60, 4x1-20/70; 5tanks, 54troops; SO-8 radar
			2	Phai	1945		
LCU	LCT(6)	6	8	Mataphon	1944		320t, 36.3x10.0x1.2m, 3d, 675hp, 8kts, 13p; 2x1-20/70; 4tanks
			9	Rawi	1944		
			10	Adang	1944		
			11	Phetra	1944		
			12	Khorum	1944		

		13	Talibong	1944		
LCI(L)	2	1	Prab	1944		385t, 48.9x7.2x1.6m, 8d(2), 2320hp, 15.5kts, 29p; 2x1-20/70; 209troops; SO radar
		2	Sattakut	1944		

MINE WARFARE

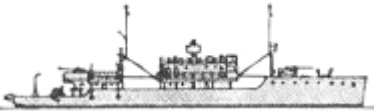
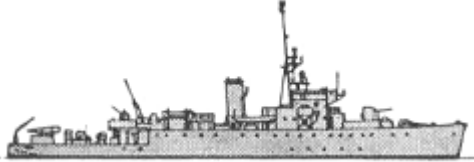
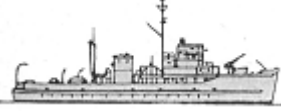

ML	Bangrachan	2	1	Bangrachan	1936		408t, 50.0ppx7.7x2.2m, 2d, 540hp, 13kts, 55p; 2x1-76/40, 142mines
			2	Nangsarai	1937		
MSO	Algerine VTE	1	1	Phosamton	1945		1335t, 68.6x10.8x3.3m, 2b,2vte, 2400hp, 16kts, 138p; 1x1-102/45, 3x1-20/70, 2dct, 2dcr, sweeps; radar, sonar
MSC	YMS	3	2	Ladya	1943		320t, 41.5x7.5x2.4m, 2d, 800hp, 14kts, 60p; 1x1-76/50, 2x1-20/70, 2dct, 2dcr, sweeps; SO radar
			3	Bangkeo	1943		
			4	Ta Din Daeng	1943		
MSB	M1	5	1-5	M1-5	1945	No picture	30t, 17.0x5.3x1.4m, 2d, 10kts, 7p; 1x1-12.7, sweeps

© Ivan Gogin, 2016

[home](#)[World navies yesterday](#)[1950](#)

Turkey 01 January 1950

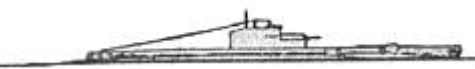
SUBMARINES

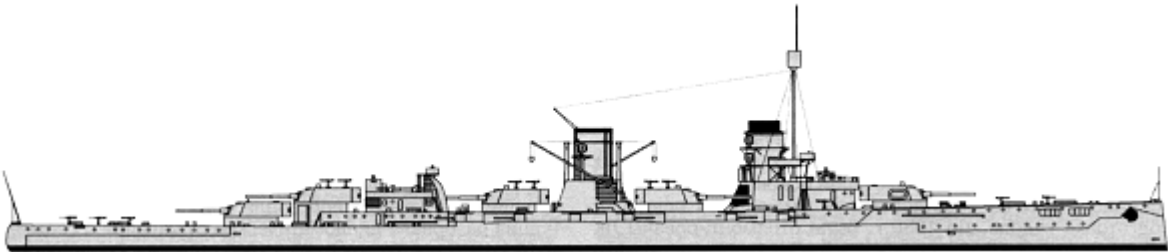
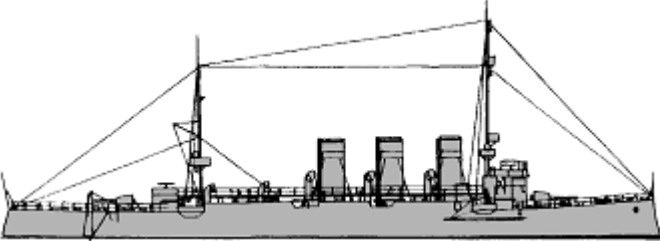

SS	Saldıray	1	Saldıray	1939		934/1210t, 80.0x6.4x4.3m, 2d/em, 3500/1000hp, 20/9kts, 44p, 100m; 1x1-105/45, 1x1-20/70, 6-533TT	
		2	Yıldıray	1946			
	Oruç Reis	3	1	Oruç Reis	1941		687/861t, 61.4x6.8x3.6m, 2d/em, 1200/780hp, 13.7/8.4kts, 35p, 100m; 1x1-102/40, 5-533TT
			2	Murat Reis	1942		
			3	Burak Reis	1942		
	Balao	4	1	Birinci İnönü	1944		1845/2415t, 95.0x8.3x4.7m, 4dg,4em(2), 5400/2740hp, 20.2/8.7kts, 60p, 120m; 2x1-127/25, 2x1-40/60, 10-533TT; SS, ST, SV radars, sonars
			2	İkinci İnönü	1944		
			3	Sakarya	1944		
			4	Gür	1944		

PRINCIPAL SURFACE COMBATANTS

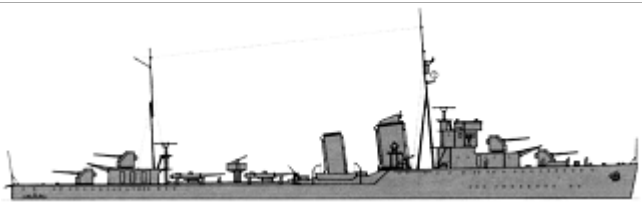
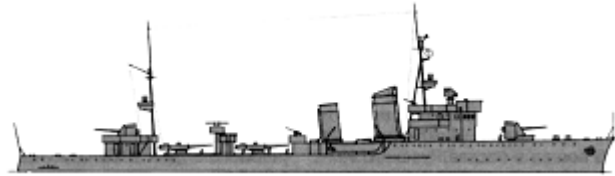
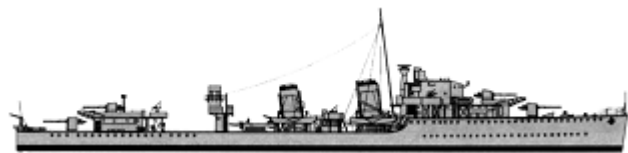
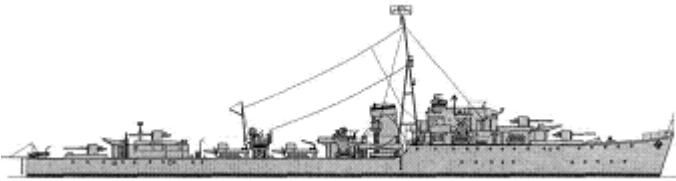
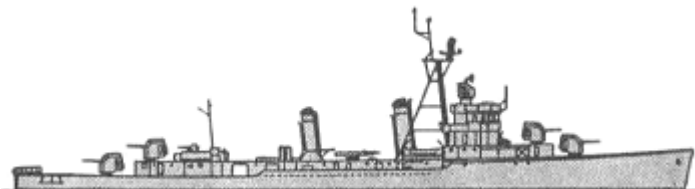
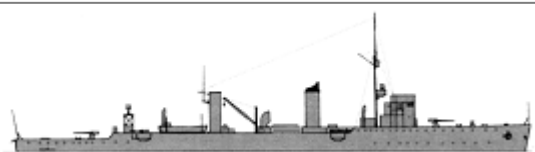
BB	Moltke	1	1	Yavuz	1912		25300t, 186.6x29.5x8.7m, 24b,4st, 52000hp, 25.5kts, 1053p; 270belt, 75decks, 230turrets, 350CT; 5x2-283/50, 10x1-149/45, 6x1-88/45, 10x1-40/60, 2-500TT
CL	Mecidiye	1	1	Mecidiye	1903		3967t, 102.4x12.8x5.3m, 16b,2vqe, 12500hp, 20kts, 312p; 102slopes, 38deck; 4x1-130/55, 4x1-76/50, 2-450TT
	Kocatepe	1	1	Kocatepe	1931		1650t, 100.2x9.4x2.9m, 3b,2gst, 40000hp, 36kts, 149p; 4x1-120/50, 3x1-40/39, 2x1-20/70, 2x3-533TT
		2	2	Adatepe	1931		





							
	Zafer	2	1	Zafer	1932		1610t, 96.0x9.3x3.3m, 3b,2gst, 35000hp, 36kts, 149p; 2x2-120/50, 2x1-40/39, 2x1-20/70, 2x3-533TT, 4dct
			2	Tinaztepe	1932		
DD	Demirhisar	3	1	Demirhisar	1942		2080t, 98.5x10.2x4.0m, 3b,2gst, 34000hp, 35.5kts, 145p; 4x1-120/45, 4x1-20/70, 2x4-533TT(1,2), 1x4-533TT(3), 2dct, 1dcr, type 271, 291 radars, sonar
			2	Sultanhisar	1942		
			3	Muavenet	1942		
O	1	1	Gayret	1941		2430t, 105.2x10.7x4.3m, 2b,2gst, 40000hp, 37kts, 212p; 4x1-120/45, 1x4-40/39, 4x1-20/70, 2x4-533TT, 4dct, 2dcr; type 272, 282, 285, 291 radars, type 123A, 127 sonars	
Bristol	4	1	Gaziantep	1942		2600t, 106.2x11.0x4.9m, 4b,2gst, 50000hp, 35kts, 208p; 4x1-127/38, 2x2-40/60, 7x1-20/70, 1x5-533TT, 6dct, 2dcr; SC, SG, Mk12/22 radars, sonar	
		2	Giresun	1942			
		3	Gelibolu	1942			
		4	Gemlik	1942			
FS	Peyk	2	1	Peyk	1907		775t, 80.1ppx8.4x4.6m, 4b,2vte, 5100hp, 18kts, 105p; 2x1-88/45, 6x1-57/45, 2x1-450TT, 25mines(2)
			2	Berk	1907		

PATROL AND COASTAL COMBATANTS

PT	Bora	5	1-5	Bora, Kasırga, Yıldırım, Şimsek, Tayfun	1942		30t, 21.8x4.9x0.8m, 4pe, 3000hp, 33kts; 1x1-20/70, 2-450TR
YP	MTB1	10	1-10	MTB1-10	1942	No picture	70t, 21.8x4.2x2.6m, 2d, 2000hp, 20kts, 8p; 1x1-20/70
	HDML	8	1-8	LSB1-8	1942-1943		54t, 22.0x4.8x1.4m, 2d, 260-320hp, 11-11.8kts, 10p; 1x1-47/40, 1x1-20/70, 2dcr, sonar
	Fairmile B	8	1-8	AB1-8	1943-1944		86t, 34.8x5.6x1.5m, 2pe, 1200hp, 18kts, 16p; 1x1-47/40, (1x2+1x1)-20/70, 2dct, 2dcr; type 286 radar, sonar

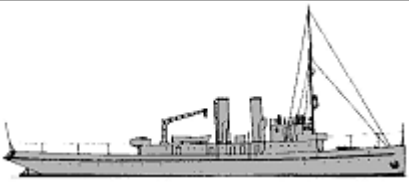
MINE WARFARE

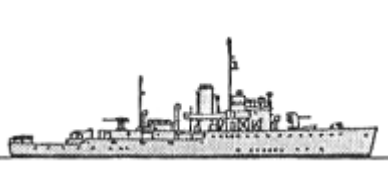
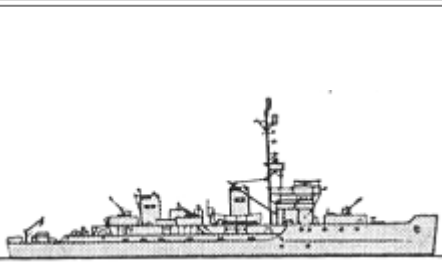

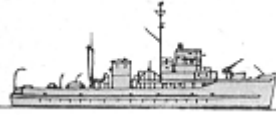

	İntibah	1	1	İntibah	1886		616t; 1x1-75/35, 50mines
--	---------	---	---	---------	------	--	--------------------------



ML							
	Atak	1	1	Atak	1938	No picture	500t, 44.0x8.0x3.6m, 1d, 1025hp, 13kts; 40mines
	Sivrihisar	2	1	Sivrihisar	1940		375t, 52.5x7.9x1.8m, 2d, 1200hp, 15kts, 60p; 1x1-75/55, 1x1-40/39, 40mines, 2dcr
2			Torgud Reis	1940			
MSO	Bathurst	5	1	Ayvalık	1942		790t, 56.7x9.5x3.0m, 2b,2vte, 1550-2000hp, 15-16kts, 80-90p; 1x1-102/45, 1x1-40/60, 2x1-20/70, 4dct, 2dcr, sweeps; radar, sonar
			2	Antalya	1942		
			3	Alanya	1942		
			4	Amasra	1942		
			5	Hamit Nacı	1942		
	Auk	8	1	Çeşme	1943		1250t, 67.4x9.8x3.3m, 2dg,2em, 2880hp, 18kts, 105p; 1x1-76/50, 6x1-20/70, 4dct, 2dcr, 80mines, sweeps; radar, sonar
			2	Çarşamba	1943		
			3	Çardak	1943		
			4	Çandarlı	1944		
			5	Edincik	1943		
			6	Erdemli	1943		
			7	Ereğli	1943		
			8	Erdemit	1943		
MSC	MMS1	3	1	Bafra	1942		295t, 36.4x7.1x2.7m, 1d, 375-500hp, 10-11kts, 20p; 2x2-12.7, sweeps
			2	Bandırma	1942		
			3	Bartın	1942		
	YMS	8	1	Kozlu	1943		320t, 41.5x7.5x2.4m, 2d, 800hp, 14kts, 60p; 1x1-76/50, 2x1-20/70, 2dct, 2dcr, sweeps; radar
			2	Kuşadası	1944		
			3	Küllük	1943		
			4	Kas	1942		
			5	Kilimli	1943		
			6	Kerempe	1943		
			7	Kemer	1943		
			8	Kirte	1944		
MSI	MMS1 (first)	2	1, 2	Kavak, Çanak	1937	No picture	52t, 22.9x4.4x1.5m, 3pe, 1500hp, 15kts, 11p; sweeps

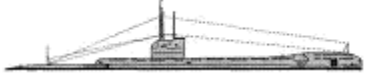
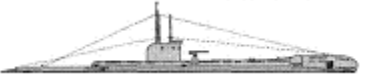
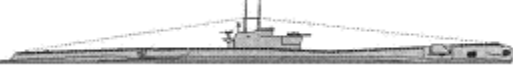

[home](#)[World navies yesterday](#)[1950](#)

United Kingdom 01 January 1950

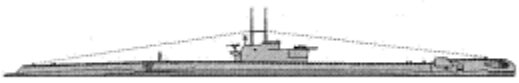
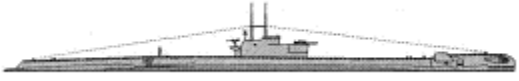
SUBMARINES

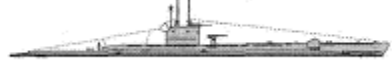
U prewar	1	N65	Ursula	1938		630/730t, 58.2x4.9x4.6m, 2d/em, 615/825hp, 11.2/10kts, 27p, 60m; 1x1-76/45, 6-533TT; sonar
U 1940	3	P42	Unbroken	1942		646/732t, 60.0x4.9x4.7m, 2dg,2em, 615/825hp, 11.2/10kts, 33p, 60m; 1x1-76/45, 4-533TT; type 291W radar, sonar
		P43	Unison	1942		
		P62	Uther	1943		
T 1940	7	P314	Tactician	1942		1327/1575t, 83.8x8.1x4.5m, 2d/em, 2500/1450hp, 15.2/9kts, 61p, 95m; 1x1-102/40, 1x1-20/70, 11-533TT; type 291W radar, sonar
		P317	Tally-Ho	1943		
		P318	Tantalus	1943		
		P319	Tantivy	1943		
		P316	Templar	1943		
		P312	Trespasser	1942		
		P315	Truculent	1942		
S war emergency	1	P214	Satyr	1943		842/990t, 66.1x7.2x4.5m, 2d/em, 1900/1300hp, 14.7/9kts, 48p, 95m; 1x1-20/70, 7-533TT; type 267QW radar, sonar
S 1940	4	P219	Seraph	1942		842/990t, 66.1x7.2x4.5m, 2d/em, 1900/1300hp, 14.7/9kts, 48p, 95m; 1x1-20/70, 7-533TT; type 267QW radar, sonar
		P226	Sirdar	1943		
		P227	Spiteful	1943		
		P229	Sportsman	1942		
S 1941 riveted	5	P237	Scythian	1944		842/990t, 66.1x7.2x4.5m, 2d/em, 1900/1300hp, 14.7/9kts, 48p, 95m; 1x1-20/70, 6-533TT(P237), 7-533TT(P242,245,246,231); type 267QW radar, sonar
		P242	Shalimar	1944		
		P245	Spirit	1943		
		P246	Statesman	1943		
		P231	Stoic	1943		
S 1941 welded	2	P243	Scotsman	1944		814/990t, 66.1x7.2x4.5m, 2d/em, 1900/1300hp, 14.7/9kts, 48p, 95m; 1x1-20/70, 6-533TT; type 267QW radar, sonar
		P244	Sea Devil	1945		
T 1941/42	6	P321	Telemachus	1943		1327/1571t, 83.4x8.1x4.5m, 2d/em, 2500/1450hp, 15.2/9kts, 61p, 95m; 1x1-102/40, 1x1-20/70, 11-533TT; type 267W radar,
		P324	Thorough	1944		
		P325	Thule	1944		

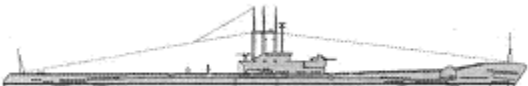
SS	riveted					sonar	
		P329	Tradewind	1943			
		P331	Trenchant	1944			
	T 1941/42 welded	11	P326	Tudor	1944		1327/1571t, 83.4x8.1x4.5m, 2d/em, 2500/1450hp, 15.2/9kts, 61p, 110m; 1x1-102/40, 1x1-20/70, 11-533TT; type 267W radar, sonar
			P334	Taciturn	1944		
			P337	Talent	1945		
			P338	Teredo	1946		
			P332	Tiptoe	1944		
			P328	Token	1945		
			P333	Trump	1944		
			P342	Tabard	1946		
			P355	Thermopylae	1945		
			P352	Totem	1945		
P353	Truncheon	1945					
P354	Turpin	1944					
T Streamlined	1	S77	Tireless	1945		1424/1571t, 83.4x8.1x4.8m, 2d/em, 2500/1450hp, 15.2/9.5kts, 50p, 95m; 6-533TT; type 267W radar, type 186, 187, 197 sonars	
S 1942/43	13	P253	Sea Scout	1944		814/990(all-P248)-842/990(P248)t, 66.1x7.2x4.3m, 2d/em, 1900/1300hp, 14.7/9kts, 48p, 110(all-P248)-95(P248)m; 1x1-20/70, 6-533TT(P252-256,258,259,261,262,264,266), 7-533TT(P248,251); type 291W radar, sonar	
		P254	Selene	1944			
		P255	Seneschal	1945			
		P256	Sentinel	1945			
		P259	Sidon	1944			
		P261	Sleuth	1944			
		P262	Solent	1944			
		P264	Springer	1945			
		P248	Sturdy	1944			
		P251	Subtle	1944			
		P252	Supreme	1944			
		P266	Sanguine	1945			
		P258	Scorcher	1945			
U long hull	7	P72	Vampire	1943		662/740t, 62.3x4.9x4.7m, 2dg,2em, 615/825hp, 11.2/10kts, 33p, 90m; 1x1-76/45, 2x1-20/70, 4-533TT; type 267QW radar, sonar	
		P76	Visigoth	1944			
		P83	Urtica	1944			
		P18	Vagabond	1945			
		P81	Varne	1944			
		P84	Vineyard	1944			
		P77	Vivid	1944			
		P411	Acheron	1948			
		P427	Aeneas	1946			
		P421	Affray	1946			

A	16	P441	Alaric	1946		1385/1620t, 85.1x6.8x5.2m, 2d/em, 4300/1250hp, 18.5/8kts, 61p, 105m; 1x1-102/33, 8-533TT; type 267W radar, sonar
		P415	Alcide	1946		
		P416	Alderney	1946		
		P417	Alliance	1945		
		P418	Ambush	1947		
		P439	Amphion	1945		
		P422	Anchorite	1947		
		P423	Andrew	1948		
		P449	Artemis	1947		
		P456	Artful	1948		
		P447	Astute	1945		
		P419	Auriga	1946		
		P426	Aurochs	1947		
SX XE	4	XE7-9, 12	-	1944		30/34t, 16.2x1.8x2.2m, 1d/em, 42/30hp, 6/5kts, 4p, 90m; 2x 2t dropped side charges

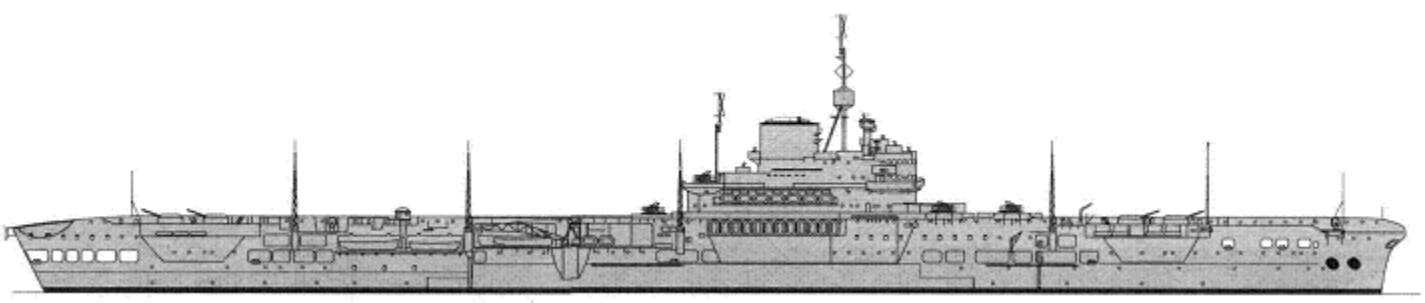
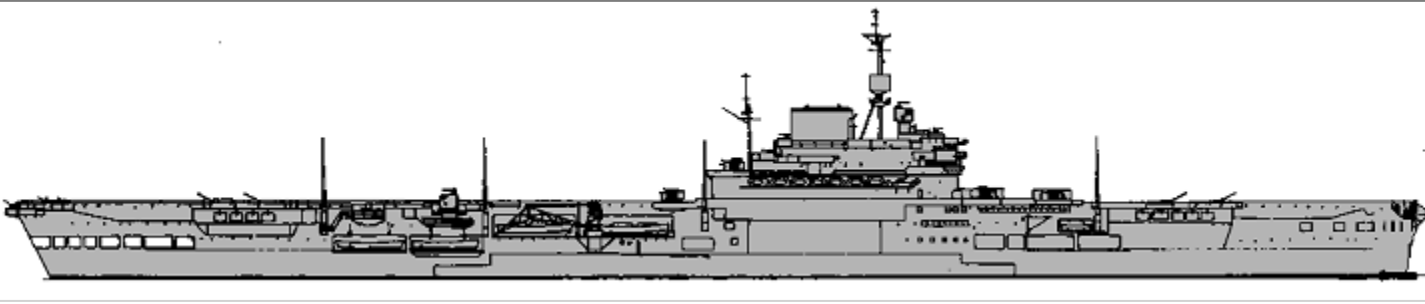

AIRCRAFT CARRIERS

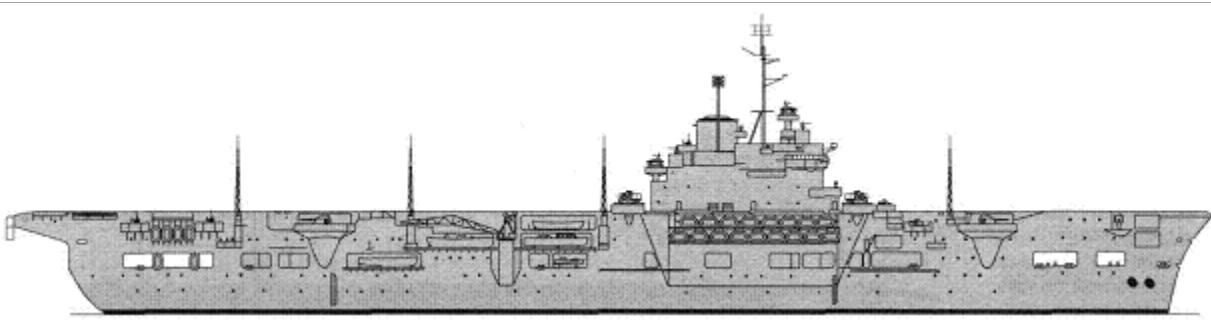
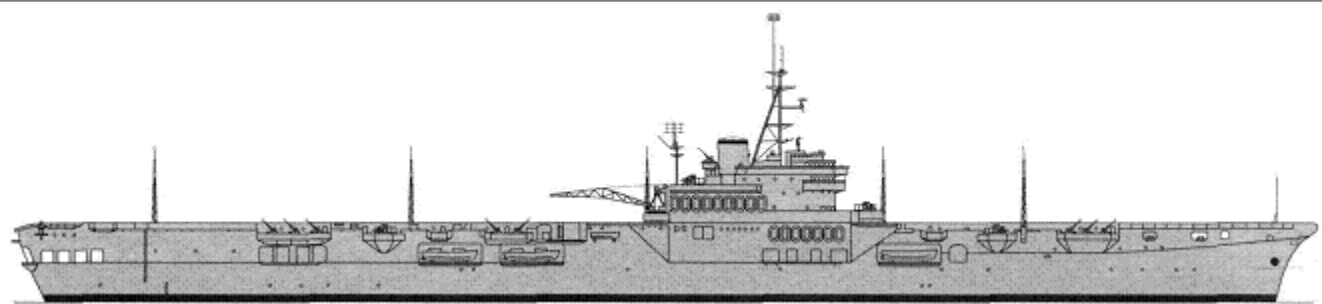
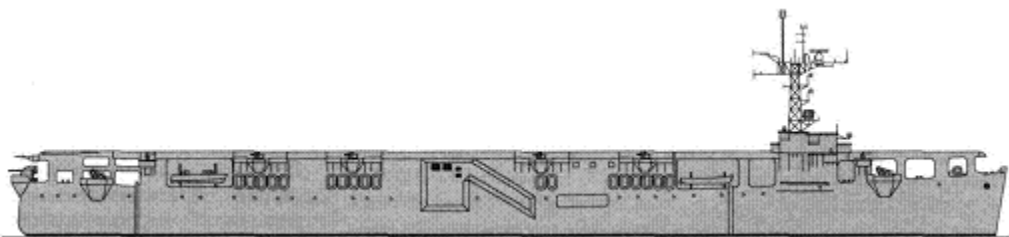

CV	Illustrious	3	87	Illustrious	1940		29240t, 229.6x32.5x8.7m, 6b,3gst, 111000hp, 30.5kts, 1997p; 114belt, 76deck; 8x2-114/45, 21x1-40/60(87), 12x1-40/60(67), (2x4+2x2+9x1)-40/60(38), 5x8-40/39(38), 6x8-40/39(87,67), 19x2-20/70(87), (11x2+12x1)-20/70(67), (16x2+13x1)-20/70(38), 33aircraft (Seafire, Firefly, Firebrand, Sea Hornet, Sea Fury fighters, Sea Hornet recon planes, Firefly ASW planes, Hoverfly helicopters); type 272, 277, 279, 281B, 6x 282, 293, SG(38) radars			
			67	Formidable	1940					
			38	Victorious	1941					
	Indomitable	1	92	Indomitable	1941				29730t, 229.8x35.4x8.8m, 6b,3gst, 111000hp, 30.5kts, 2100p; 114belt, 76deck; 8x2-114/45, (2x4+2x2+13x1)-40/60, 6x8-40/39, (12x2+12x1)-20/70, 45aircraft (Seafire, Firefly, Firebrand, Sea Hornet, Sea Fury fighters, Sea Hornet recon planes, Firefly ASW planes, Hoverfly helicopters); type 272, 277, 279, 281B, 6x 282, 293, SM-1 radars	
										Indefatigable
	Indefatigable	2	86	Implacable	1944					

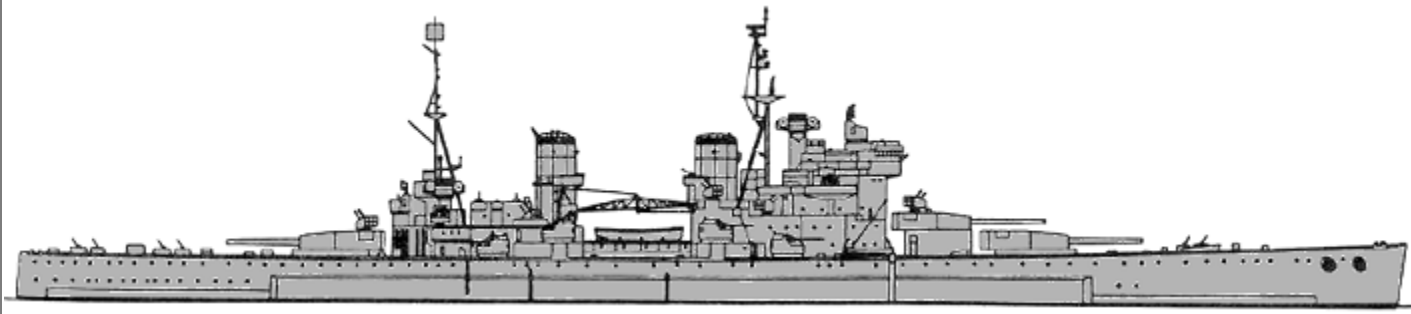
CVL	Unicorn	1	172	Unicorn	1943		20300t, 196.9x27.4x7.3m, 4b,2gst, 40000hp, 24kts, 1200p; 51deck; 4x2-102/45, 4x4-40/39, (5x2+6x1)-20/70, 35aircraft (Seafire, Firefly, Firebrand, Sea Hornet, Sea Fury fighters, Sea Hornet recon planes, Firefly ASW planes, Hoverfly helicopters); type 281B, 282, 285 radars
	Colossus	6	62 71 31 64 68 16	Glory Vengeance Warrior Theseus Ocean Triumph	1945 1945 1946 1946 1945 1946		18040(62,71,68)-18300(31,64,16)t, 211.8x24.4x7.1m, 4b,2gst, 40000hp, 25kts, 1300p; 17x1-40/60(62), 12x1-40/60(71), 19x1-40/60(31,64), 28x1-40/60(68), 12x1-40/60(16), 6x4-40/39, 37aircraft (Seafire, Firefly, Firebrand, Sea Hornet, Sea Fury fighters, Sea Hornet recon planes, Firefly ASW planes, Hoverfly helicopters), type 79B(62,71,31,64,16), 281B(62,71,31,64,16), 293(68), SM-1(68) radars, type 144 sonar
CVE	Campania	1	D48	Campania	1944		15970t, 164.6x21.3x7.0m, 2d, 12000hp, 17kts, 700p; 1x2-102/45, 6x4-40/39, 8x2-20/70, 18aircraft (Seafire, Firefly, Firebrand, Sea Hornet, Sea Fury fighters, Sea Hornet recon planes, Firefly ASW planes, Hoverfly helicopters); type 277, 291 radars
AV	Ripon	5	F106 F122 F116 F113 F114	Ripon Roc Walrus Blackburn Seafox	1945 1945 1945 1946 1946	No picture	990t, 64.0x10.7x4.2m, 2d, 960hp, 10.5kts; 1x1-76/40, 2x1-20/70

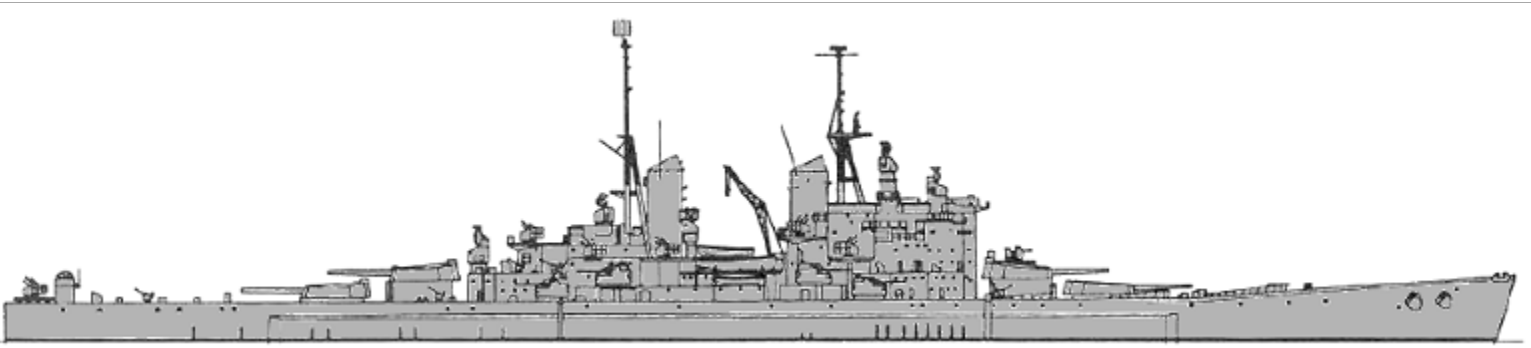
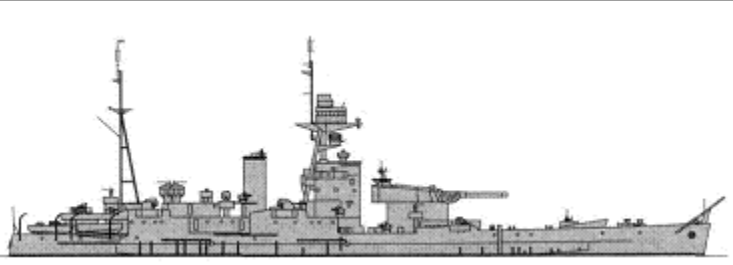
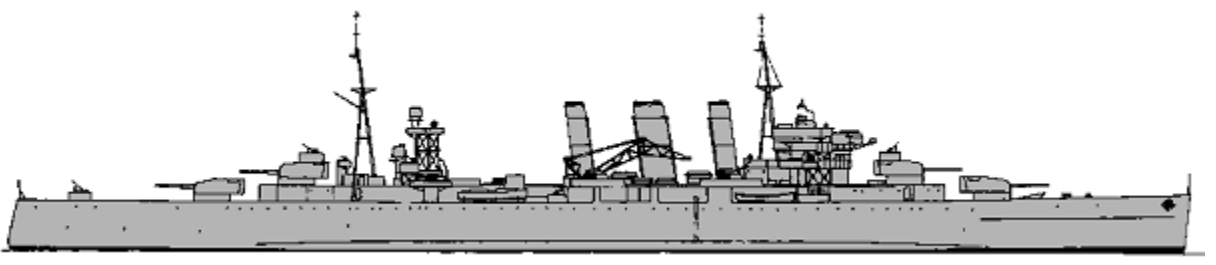
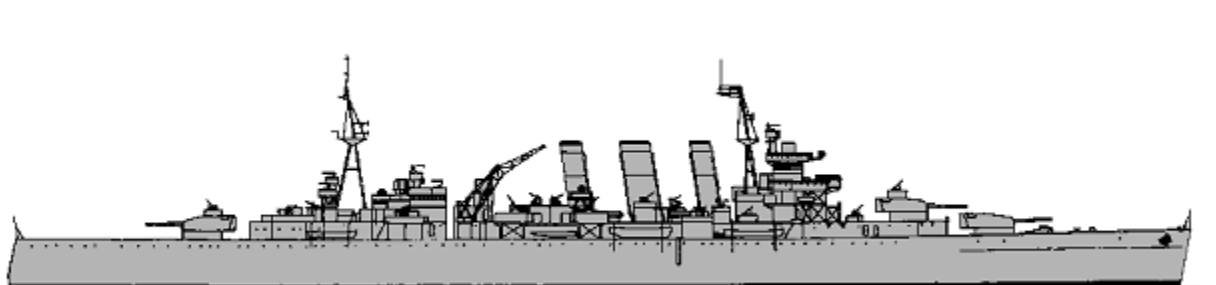
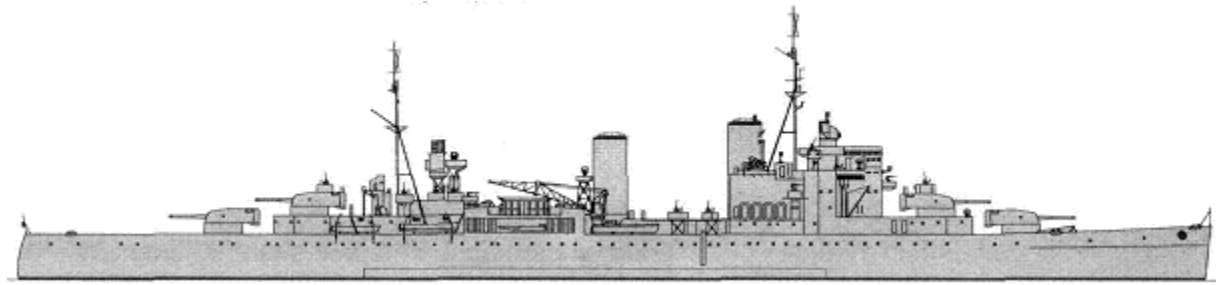

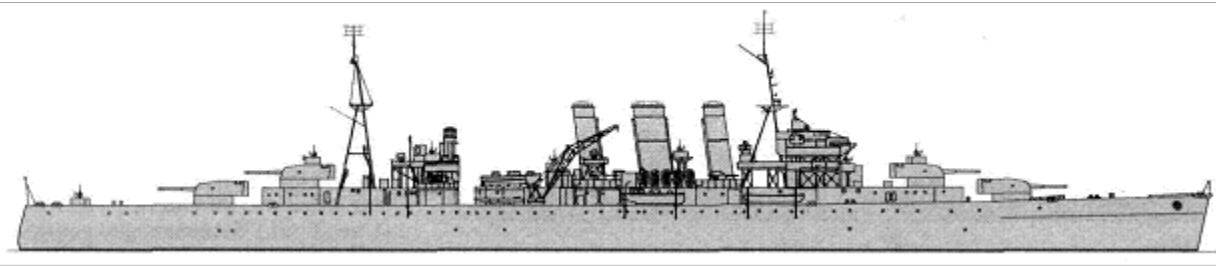
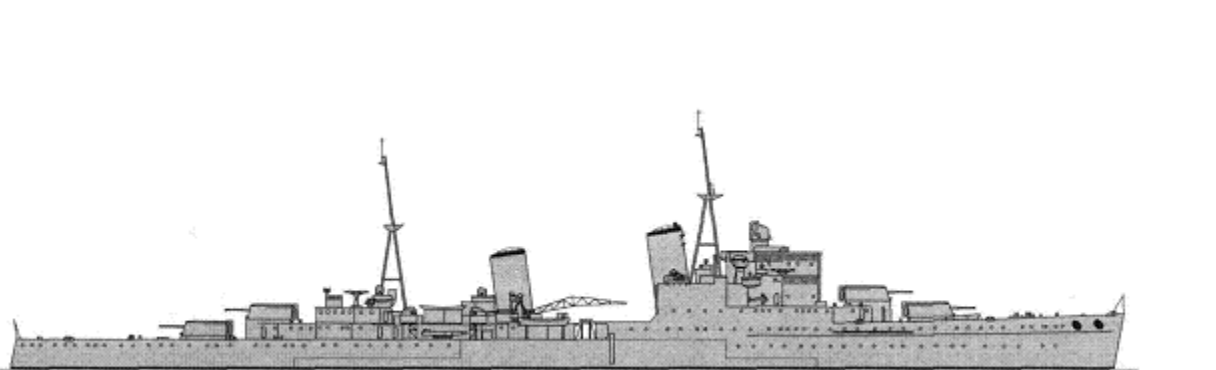
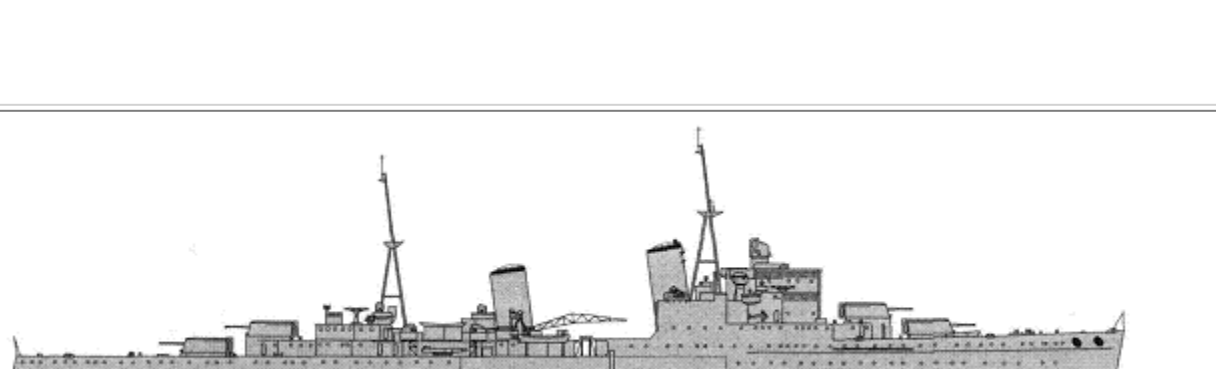
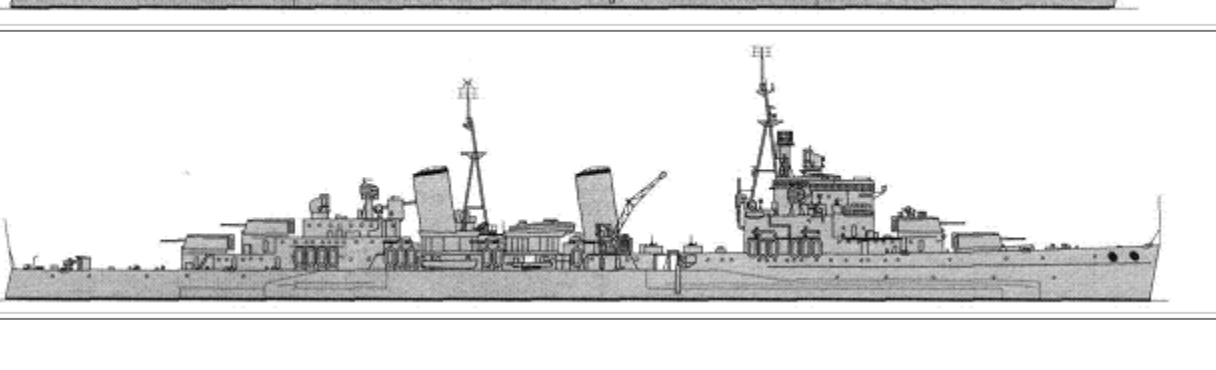

PRINCIPAL SURFACE COMBATANTS



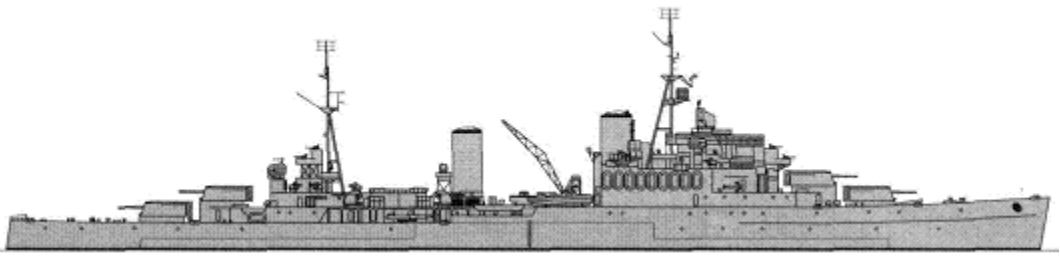
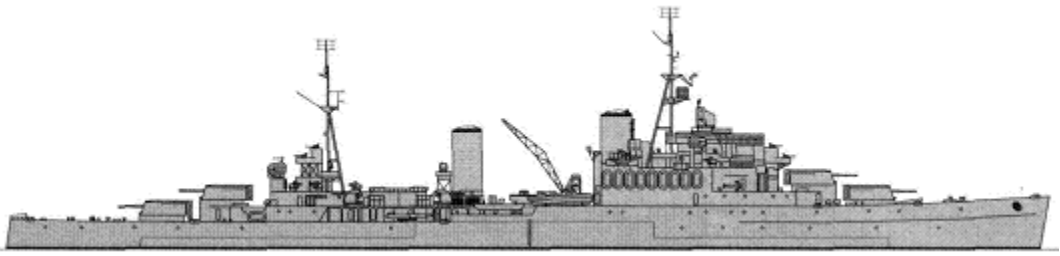
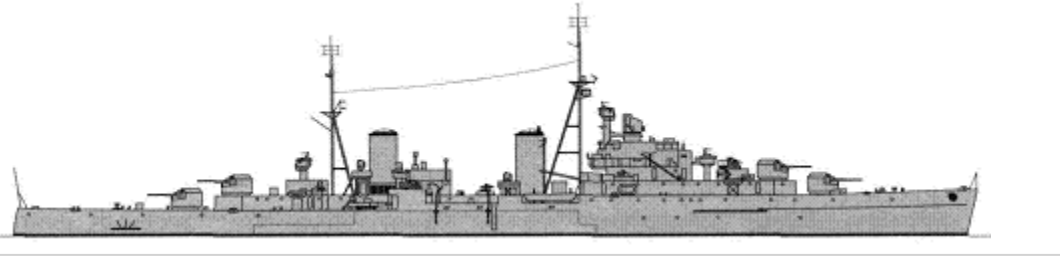
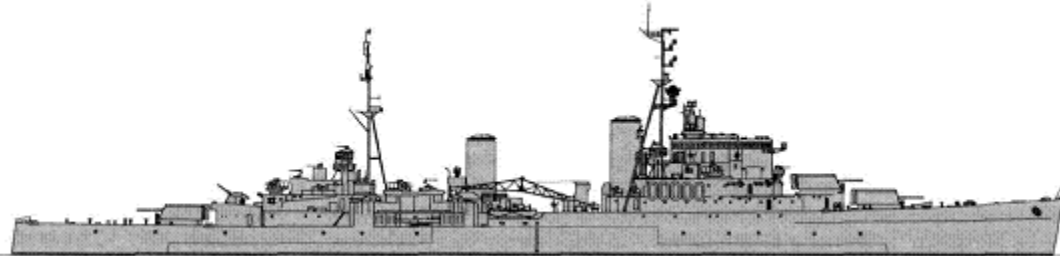

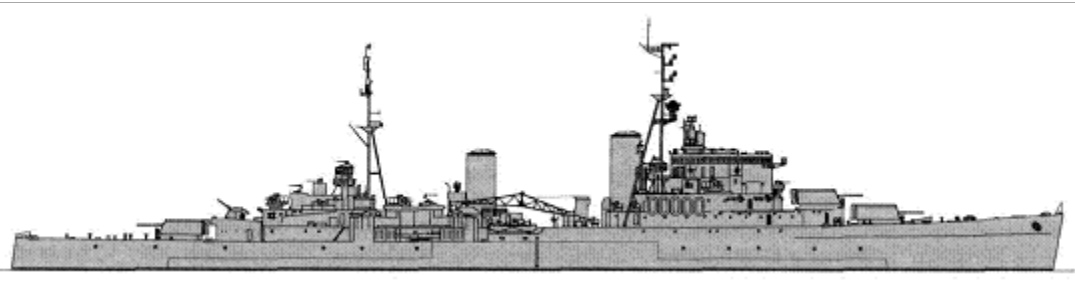
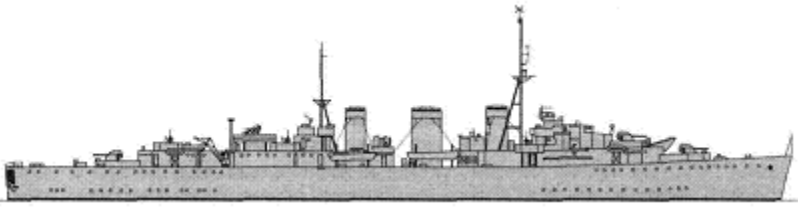
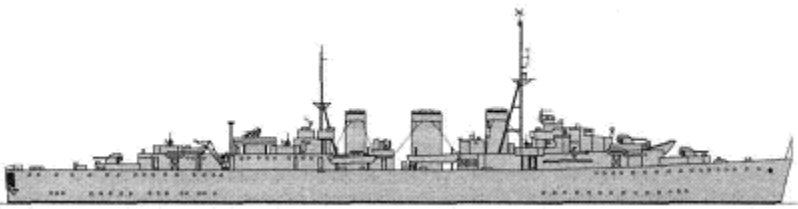
BB	King George V	4	41	King George V	1940		42076t, 227.1x31.4x8.8m, 8b,4gst, 110000hp, 28kts, 1422p; 381belt, 152deck, 330turrets, 114CT; (2x4+1x2)-356/45, 8x2-133/50, (2x4+2x1)-40/60(41), 2x4-40/60(17), (2x4+6x1)-40/60(79), 10x1-40/60(32), 8x8-40/39(41), (8x8+2x4)-40/39(17), 8x8-40/39(32), (8x8+2x4)-40/39(79), 8x2-20/70(17), 2x1-20/70(79), 4x2-20/70(32); type 274(41,32), 2x 274(17,79), 277, 279B(41), 281B(17,32,79), 4x 285(17), 5x 285(41,32), 9x 282(41), 8x 282(17,32), 293, 7x 262(79), 4x 275(79) radars, type 651 jammer(79)
			17	Duke of York	1941		
			79	Anson	1942		
			32	Howe	1942		

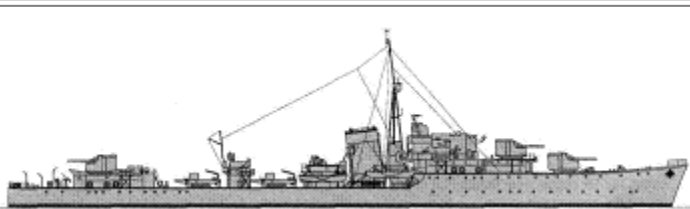
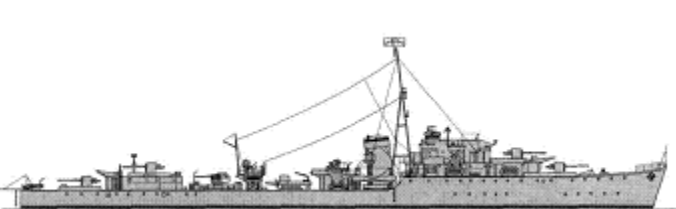
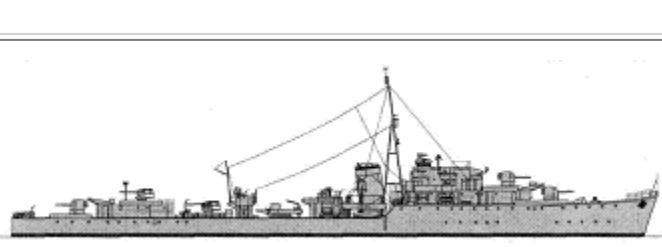

	Vanguard	1	23	Vanguard	1946		51420t, 248.2x32.9x9.4m, 8b,4gst, 130000hp, 30kts, 1975p; 356belt, 152deck, 330turrets, 76CT; 4x2-381/42, 8x2-133/50, (10x6+1x2+11x1)-40/60; type 960, 277, 293, 268, 930, 2x 274, 4x 275, 11x 262 radars
MON	Roberts	2	F40	Roberts	1941		9150(F40)-9717(F109)t, 113.8x27.4x4.4m, 2b,2gst, 4800hp, 12.5kts, 460p; 381belt, 102deck, 330turret, 76CT; 1x2-381/42, 4x2-102/45, 8x1-40/60(F40), (1x8+2x4)-40/39, 20x1-20/70(F40), 8x1-20/70(F109); type 268(F40), 279(F40), 3x 282, 2x 285, 293(F109), 79B(F109) radars
			F109	Abercrombie	1943		
CA	Kent	1	57	Cumberland	1928		14910t, 192.9x20.8x6.9m, 8b,4gst, 80000hp, 31.5kts, 710p; 114belt, 38deck, 25turrets; 4x2-203/50, 4x2-102/45, 2x4-40/39, (5x2+6x1)-20/70, 2x4-533TT; type 273, 281, 285 radars
	Devonshire	2	39	Devonshire	1929		14580t, 192.9x20.1x6.9m, 4b,4gst(39)-8b,4gst(96), 40000(39)-80000(96)hp, 21(39)-32.3(96)kts, 700p; 25belt, 38deck, 25turrets; 1x2-203/50(39), 3x2-203/50(96), 2x2-102/45(39), 4x2-102/45(96), 1x1-40/60(39), 1x4-40/39(39), 6x8-40/39(96), 3x1-20/70(39), (4x2+6x1)-20/70(96), 2x4-533TT; type 273, 281B, 282, 283, 285, 293 radars
			96	Sussex	1929		
	London	1	69	London	1929		14580t, 192.9x20.1x6.9m, 4b,4gst(39)-8b,4gst(96), 40000(39)-80000(96)hp, 21(39)-32.3(96)kts, 700p; 89belt, 38deck, 25turrets; 4x2-203/50, 4x2-102/45, 4x1-40/60, 2x8-40/39, 8x1-20/70, 2x4-533TT; type 273, 279, 284, 285 radars
Norfolk	1	78	Norfolk	1930		14600t, 193.7x20.1x6.9m, 8b,4gst, 80000hp, 32.3kts, 710p; 25belt, 38deck, 25turrets; 3x2-203/50, 4x2-102/45, 10x1-40/60, 6x4-40/39, 11x2-	

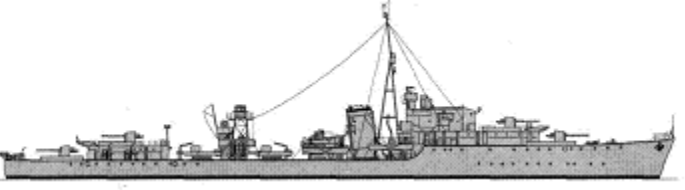

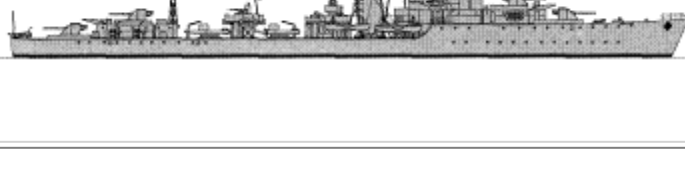

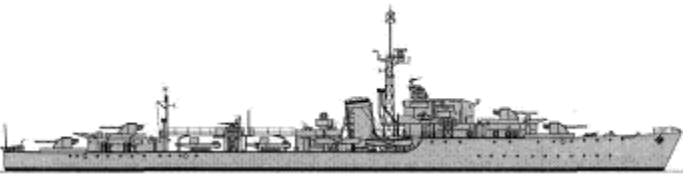

						20/70, 2x4-533TT; type 274, 277, 281B, 283, 285, 293 radars
Southampton	4	19	Birmingham	1937		12190t, 180.3x18.8x6.2m, 4b,4gst, 75000hp, 32kts, 748p; 114belt, 38deck, 25turrets; 3x3-152/50(19,21,24), 4x3-152/50(76), 4x2-102/45, 4x4-40/60(19), (4x4+10x1)-40/60(24), 2x4-40/39(19,76,24), (4x4+4x1)-40/39(21), (10x2+9x1)-20/70(19), (6x2+6x1)-20/70(21), (4x2+13x1)-20/70(76), (10x2+7x1)-20/70(24), 2x3-533TT; type 273(19,76), 274(21), 277(24), 281(24,76), 281B(19,21), 282(24,76), 283(24), 284, 285(24,21,76), 294(21) radars
		21	Glasgow	1937		
		76	Newcastle	1937		
		24	Sheffield	1937		
Gloucester	1	11	Liverpool	1938		12330t, 180.3x19.0x6.6m, 4b,4gst, 82500hp, 32.3kts, 748p; 114belt, 51deck, 102turrets; 3x3-152/50, 4x2-102/45, (6x4+4x1)-40/39, (6x2+7x1)-20/70, 2x3-533TT; type 274, 277, 279B, 282, 283, 285, 286, 293 radars
Edinburgh	1	35	Belfast	1939		14900t, 187.0x20.2x7.1m, 4b,4gst, 80000hp, 30.5kts, 850p; 114belt, 76deck, 102turrets; 4x3-152/50, 4x2-102/45, 5x1-40/60, (2x8+4x4+4x1)-40/39, (2x2+4x1)-20/70, 2x3-533TT; type 268, 274, 277, 281B, 282, 285, 293 radars
Dido	5	61	Argonaut	1942		7515t, 156.1x15.4x5.5m, 4b,4gst, 62000hp, 32.3kts, 530p; 76belt, 51deck, 13turrets; 4x2-133/50(61,33,42,43), 5x2-133/50(37), 7x1-40/60(61), 3x4-40/60(33,43), 3x4-40/39(61,42), 2x4-40/39(37,43), 6x1-20/70(61), (6x2+1x1)-20/70(33), (4x2+2x1)-20/70(37), (6x2+5x1)-20/70(42), (6x2+4x1)-20/70(43), 2x3-533TT; type 272(37,42,43), 277(33,61), 279(37,43), 281(37,42,43), 281B(33,61), 282(37,42),
		33	Cleopatra	1941		
		37	Dido	1940		
		42	Euryalus	1941		
		43	Phoebe	1940		

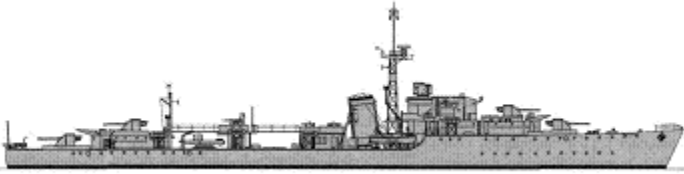

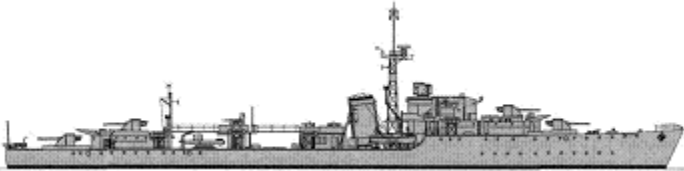
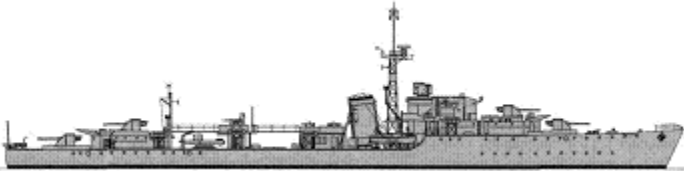
							284(61,42,43,37), 285, 293(33,61) radars
CL	Fiji	6	52	Bermuda	1942		11090t, 169.3x18.9x6.3m, 4b,4gst, 72500hp, 31.5kts, 730p; 89belt, 51deck, 51turrets; 3x3-152/50(52,44,14,80), 4x3-152/50(48,60), 4x2-102/45, 4x1-40/60(52,60), 2x1-40/60(44), (5x2+8x1)-40/60(14), (5x4+4x1)-40/39(52), 2x4-40/39(48,14,60), 5x4-40/39(44,80), (2x2+2x1)-20/70(52), 10x2-20/70(48), (2x2+10x1)-20/70(44), 8x2-20/70(60), 24x1-20/70(80), 2x3-533TT, type 272(48,44,14,60), 273(52,44,80), 277(52), 279(14,60,80), 281(48,44,14,60,80), 281B(52), 282(14,60), 283(14,48,60), 284(52,48,44,60,14,80), 285(52,48,44,80,14), 293(52) radars
			48	Gambia	1942		
			44	Jamaica	1942		
			14	Kenya	1940		
			60	Nigeria	1940		
			80	Mauritius	1941		
	Newfoundland	2	30	Ceylon	1943		11090t, 169.3x18.9x6.3m, 4b,4gst, 72500hp, 31.5kts, 730p; 89belt, 51deck, 51turrets; 3x3-152/50, 4x2-102/45, 4x1-40/60(30), 2x4-40/60(59), 3x4-40/39, (6x2+2x1)-20/70(30), (10x2+2x1)-20/70(59), 2x3-533TT; type 272(30), 274(59), 277(59), 281(30), 281B(59), 283, 284(30), 285, 293(59) radars
59			Newfoundland	1943			
	Bellona	2	84	Diadem	1944		7410t, 156.1x15.4x5.5m, 4b,4gst, 62000hp, 32kts, 530p; 76belt, 51deck, 13turrets; 4x2-133/50, 3x4-40/39, (8x2+6x1)-20/70(84), (2x2+4x1)-20/70(89), 2x3-533TT; type 272, 281, 282, 284, 285 radars
89			Royalist	1943			
	Swiftsure	1	08	Swiftsure	1944		11240t, 169.3x19.2x6.5m, 4b,4gst, 72500hp, 31.5kts, 855p; 89belt, 51deck, 51turrets; 3x3-152/50, 5x2-102/45, 13x1-40/60, 4x4-40/39, 2x3-533TT; type 277, 281B, 282, 283, 284, 285, 293 radars
	Superb	1	25	Superb	1945		11560t, 169.3x19.5x6.4m, 4b,4gst, 72500hp, 31.5kts, 867p; 89belt, 51deck, 51turrets; 3x3-152/50, 5x2-102/45, 8x1-40/60, (4x4+2x1)-40/39, (2x2+2x1)-20/70, 2x3-533TT; type 277, 281B, 282, 283, 284, 285, 293 radars



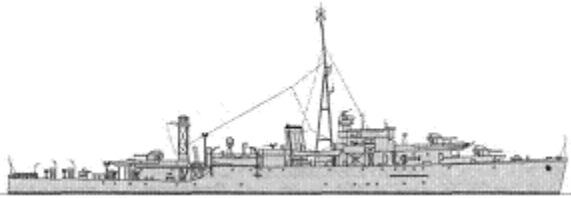

							
CM	Abdiel	1	M70	Manxman	1941		3415t, 127.4x12.2x4.6m, 4b,2gst, 72000hp, 39.7kts, 246p; 3x2-102/45, 1x4-40/39, (4x2+4x1)-20/70, 156mines; type 276, 282, 285, 286, 291 radars
	Apollo	2	M01	Apollo	1944		4100t, 127.4x12.2x4.9m, 4b,2gst, 72000hp, 39.7kts, 257p; 2x2-102/45, (2x2+6x1)-40/60(M01), (3x2+5x1)-40/60(M65), 156mines; type 272(M01), 276(M65), 282, 285, 291 radars
			M65	Ariadne	1943		
N		5	G97	Napier	1940		2555t, 108.7x10.9x4.3m, 2b,2gst, 40000hp, 36kts, 218p; 3x2-120/45, 1x1-40/60(G38), 1x4-40/39, (4x2+2x1)-20/70, 2x5-533TT(G97,25,65,47), 1x5-533TT(G38), 4dct, 2dcr; type 271, 285, 290 radars, sonar
			G25	Nepal	1942		
			G38	Nizam	1941		
			G65	Noble	1940		
			G47	Norman	1941		
M		5	G35	Marne	1941		2840t, 110.5x11.2x4.5m, 2b,2gst, 48000hp, 36kts, 226p; 3x2-120/50, 1x4-40/39, (4x2+2x1)-20/70, 2x4-533TT, 2dct, 1dcr; type 271, 282, 285, 290 radars, sonar
			G52	Matchless	1942		
			G73	Meteor	1942		
			G14	Milne	1942		
			G86	Musketeer	1942		
O		5	G04	Onslaught	1941		2430t, 105.2x10.7x4.3m, 2b,2gst, 40000hp, 37kts, 212p; 4x1-120/45(G04), 4x1-102/45(G39,48,80,98), 1x4-40/39, (2x2+2x1)-20/70, 2x4-533TT, 4dct, 2dcr, 60mines(G39,48,80,98); type 272, 282, 285, 291 radars, type 123A, 127 sonars
			G39	Obdurate	1942		
			G48	Obedient	1942		
			G80	Opportune	1942		
			G98	Orwell	1942		
P		3	G69	Paladin	1941		2430t, 105.2x10.7x4.3m, 2b,2gst, 40000hp, 37kts, 212p; 4x1-102/45(G69,77), 2x2-102/45(G56), 1x4-40/39, (2x2+2x1)-20/70(G69,77), (2x2+4x1)-20/70(G56), 2x4-533TT, 4dct, 2dcr; type 272, 282, 285, 291 radars, type 123A, 127 sonars
			G77	Penn	1942		
			G56	Petard	1942		
			H32	Rapid	1943		2480t, 109.2x10.9x4.3m, 2b,2gst, 40000hp, 36.7kts, 225p; 4x1-120/45,
			H85	Relentless	1942		

R	4	H92	Rocket	1943		1x4-40/39, (2x2-4x1)-20/70, 2x4-533TT, 4dct, 3dcr; type 272, 282, 285, 291 radars, type 123A, 127 sonars
		H95	Roebuck	1943		
S	1	G20	Savage	1943		2545t, 110.6x10.9x4.4m, 2b,2gst, 40000hp, 36.7kts, 225p; (1x2+2x1)-114/45, 6x2-20/70, 2x4-533TT, 4dct, 2dcr; type 275, 277, 282, 291 radars, type 123A, 127 sonars
T	8	R00	Troubridge	1943		2545t, 110.6x10.9x4.4m, 2b,2gst, 40000hp, 36.7kts, 225p; 4x1-120/45, (1x2+2x1)-40/60(R23,45,00,67,33), (1x2+5x1)-40/60(R89,11,56), 2x2-20/70(R45,23,00,67,33), 2x4-533TT, 4dct, 2dcr; type 275, 277, 282, 291 radars, type 123A, 127 sonars
		R23	Teazer	1943		
		R45	Tenacious	1943		
		R89	Termagant	1943		
		R33	Terpsichore	1944		
		R11	Tumult	1943		
		R56	Tuscan	1943		
R67	Tyrian	1943				
U	8	R97	Grenville	1943		2545t, 110.6x10.9x4.4m, 2b,2gst, 40000hp, 36.7kts, 225p; 4x1-120/45, 1x2-40/60(R97,83,53,42,22,99), (1x2+4x1)-40/60(R05), 1x4-40/39(R69), 4x2-20/70(R97,83,53,42,22,69,99), 2x4-533TT, 4dct, 2dcr; type 275, 277, 282, 291 radars, type 123A, 127 sonars
		R83	Ulster	1943		
		R69	Ulysses	1943		
		R53	Undaunted	1944		
		R42	Undine	1943		
		R05	Urania	1944		
		R99	Urchin	1943		
R22	Ursa	1944				
V	5	R50	Venus	1943		2545t, 110.6x10.9x4.4m, 2b,2gst, 40000hp, 36.7kts, 225p; 4x1-120/45, (1x2+4x1)-40/60(R50,93,28), 1x2-40/60(R75), 6x1-40/60(R41), 1x4-40/39(R41), 2x2-20/70(R28), 4x2-20/70(R75), 2x4-533TT, 4dct, 2dcr; type 275, 277, 282, 291 radars, type 123A, 127 sonars
		R28	Verulam	1943		
		R93	Vigilant	1943		
		R75	Virago	1943		
		R41	Volage	1944		
W	8	R03	Kempenfelt	1943		2545t, 110.6x10.9x4.4m, 2b,2gst, 40000hp, 36.7kts, 225p; 4x1-120/45, (1x2+1x1)-40/60(R03,98), (1x2+3x1)-40/60(R59), 1x2-40/60(R87,48,72), 1x1-40/60(R78,37), 2x1-40/39(R72), 1x4-40/39(R78,37), 4x2-20/70(R03,98,87,48,78,37), 2x2-20/70(R59,72), 2x4-533TT, 4dct, 2dcr; type 275, 277, 282, 291 radars, type 123A, 127 sonars
		R98	Wager	1944		
		R59	Wakeful	1944		
		R78	Wessex	1944		
		R37	Whelp	1944		
		R87	Whirlwind	1944		
		R72	Wizard	1944		
		R48	Wrangler	1944		
		R06	Myngs	1944		2575t, 110.6x10.9x4.4m, 2b,2gst,

DD	Z	8	R66	Zambesi	1944		40000hp, 36.7kts, 222p; 4x1-114/45, (1x2+1x1)-40/60(R06), 1x2-40/60(R55,39,81,02,54,55), (1x2+4x1)-40/60(R95,19), 2x1-40/39(R06), 2x1-20/70(R06), (2x2+2x1)-20/70(R39,81,02,54), 4x2-20/70(R55), 2x4-533TT, 4dct, 2dcr; type 275, 277, 282, 291 radars, type 123A, 127 sonars
			R39	Zealous	1944		
			R81	Zebra	1944		
			R95	Zenith	1944		
			R19	Zephyr	1944		
			R02	Zest	1944		
			R54	Zodiac	1944		
	Ca	8	R15	Cavendish	1945		2575t, 110.6x10.9x4.4m, 2b,2gst, 40000hp, 36.7kts, 222p; 4x1-114/45, 1x2-40/60(R15,30,25,62,85), (1x2+1x1)-40/60(R07), (1x2+4x1)-40/60(R73), 2x1-40/39(R07), (1x4+4x1)-40/39(R01), 4x2-20/70(R15,85), (2x2+2x1)-20/70(R30,25,62), 2x4-533TT, 4dct, 2dcr; type 275, 277, 282, 291 radars, type 123A, 127 sonars
			R07	Caesar	1944		
			R85	Cambrian	1944		
			R01	Caprice	1944		
			R30	Carron	1944		
			R25	Carysfort	1945		
			R62	Cassandra	1944		
	R73	Cavalier	1944				
	Battle batch 1	16	R14	Armada	1945		3300t, 115.5x12.3x4.6m, 2b,2gst, 50000hp, 35.7kts, 222p; 2x2-114/45, (4x2+4x1)-40/60, 2x4-533TT, 1x3-305 Squid ASWRL, 4dct, 2dcr; type 262, 275, 277, 283, 291, 293 radars, type 123A, 127 sonars
			R80	Barfleur	1944		
			R09	Cadiz	1946		
			R32	Camperdown	1945		
			R55	Finisterre	1945		
			R47	Gabbard	1946		
			R24	Gravelines	1946		
			R74	Hogue	1945		
			R44	Lagos	1945		
			R65	St. James	1946		
			R18	St. Kitts	1946		
			R84	Saintes	1946		
			R60	Sluys	1946		
R70			Solebay	1945			
R77	Trafalgar	1945					
R31	Vigo	1946					
Ch	8	R52	Chaplet	1945		2535t, 110.6x10.9x4.4m, 2b,2gst, 40000hp, 36.7kts, 222p; 3x1-114/45, (1x2+4x1)-40/60, 2x1-20/70, 1x4-533TT, 2x3-305 Squid ASWRL, 2dct, 2dcr; type 275, 277, 282, 291 radars, type 123A, 127 sonars	
		D29	Charity	1945			
		D61	Chequers	1945			
		D90	Cheviot	1945			
		R51	Chevron	1945			
		D36	Chieftain	1946			
		D91	Childers	1945			
D21	Chivalrous	1946					
		D34	Cockade	1945			
		D26	Comet	1945			

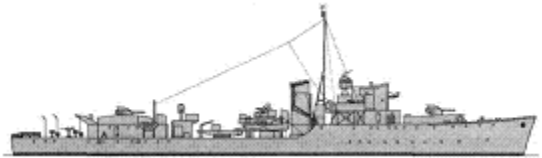
Co	8	D20	Comus	1946		2535t, 110.6x10.9x4.4m, 2b,2gst, 40000hp, 36.7kts, 222p; 3x1-114/45, (1x2+4x1)-40/60, 2x1-20/70, 1x4-533TT, 2x3-305 Squid ASWRL, 2dct, 2dcr; type 275, 277, 282, 291 radars, type 123A, 127 sonars
		D03	Concord	1946		
		D76	Consort	1946		
		D71	Constance	1945		
		D48	Contest	1945		
		D57	Cossack	1945		
Cr	2	D82	Creole	1946		2535t, 110.6x10.9x4.4m, 2b,2gst, 40000hp, 36.7kts, 222p; 3x1-114/45, (1x2+2x1)-40/60, 2x1-20/70, 1x4-533TT, 2dct, 2dcr; type 275, 277, 282, 291 radars, type 123A, 127 sonars
		D168	Crispin	1946		
Battle batch 2	8	I06	Agincourt	1947		3420t, 115.5x12.3x4.7m, 2b,2gst, 50000hp, 35.7kts, 306p; (2x2+1x1)-114/45, (3x2+2x1)-40/60, 2x5-533TT, 1x3-305 Squid ASWRL; type 262, 275, 277, 283, 291, 293 radars, type 170, 174/177 sonars
		I22	Aisne	1947		
		I17	Alamein	1948		
		I68	Barrosa	1947		
		I97	Corunna	1947		
		I09	Dunkirk	1946		
		I16	Jutland	1947		
I43	Matapan	1947				
Weapon	4	G18	Battleaxe	1947		2825t, 111.3x11.6x4.5m, 2b,2gst, 40000hp, 34kts, 286p; 2x2-102/45, (2x2+2x1)-40/60, 2x5-533TT, 2x3-305 Squid ASWRL; type 262, 275, 277, 291, 293, 903 radars, type 170, 174/177 sonars
		G31	Broadsword	1948		
		G96	Crossbow	1948		
		G64	Scorpion	1947		
Shoreham	1	L34	Falmouth	1932		1515t, 85.8x10.7x3.4m, 2b,2gst, 2000hp, 16.5kts, 100p; 2x1-102/45, (2x2+2x1)-20/70, 4dct, 2dcr; radar, sonar
Bittern	1	U81	Stork	1936		1790t, 86.0x11.3x3.5m, 2b,2gst, 3300hp, 18.7kts, 156p; 2x2-102/45, 4x1-20/70, 1x24-178 Hedgehog ASWRL, 4dct, 2dcr; radar, sonar
Egret	1	U86	Pelican	1939		1790t, 89.2x11.4x3.4m, 2b,2gst, 3600hp, 19.2kts, 188p; 3x2-102/45, 1x4-40/39, 4x1-20/70, 4dct, 2dcr; radar, sonar
Black Swan	3	U57	Black Swan	1940		1945t, 91.3x11.4x3.6m, 2b,2gst, 4300hp, 19.7kts, 180p; 3x2-102/45, 1x4-40/39, (2x2+2x1)-20/70, 1x24-178 Hedgehog ASWRL, 4dct, 2dcr, 34mines(U57); type 285 radar, type
		U03	Erne	1941		
		U18	Flamingo	1939		

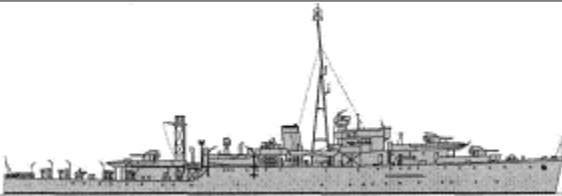
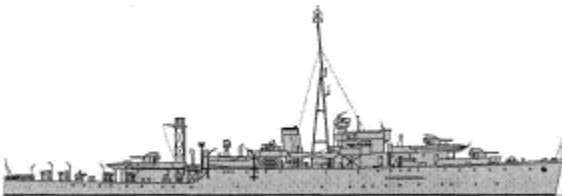
					123A, 177 sonars	
Hunt batch 1	17	L05	Atherstone	1940		1450t, 85.3x8.8x3.8m, 2b,2gst, 19000hp, 28kts, 147p; 2x2-102/45, 1x2-40/60(L82), 1x4-40/39(L42), (1x4+1x1)-40/39(all-L42,L82), 1x1-40/39(L82), 2x1-20/70, 2dct, 1dcr; type 285 radar, type 123A, 177 sonars
		L24	Blencathra	1940		
		L42	Brocklesby	1941		
		L35	Cattistock	1940		
		L46	Cleveland	1940		
		L54	Cotswold	1940		
		L78	Cottesmore	1940		
		L87	Eglinton	1940		
		L11	Fernie	1940		
		L20	Garth	1940		
		L37	Hambledon	1940		
		L48	Holderness	1940		
		L82	Meynell	1940		
		L92	Pytchley	1940		
		L58	Quantock	1941		
L25	Southdown	1940				
L45	Whaddon	1941				
Hunt batch 2	21	L06	Avon Vale	1941		1625t, 85.3x9.6x3.8m, 2b,2gst, 19000hp, 27kts, 168p; 3x2-102/45, 2x1-40/60(L14,08), (1x4+1x1)-40/39(L06,26,52,88,90), 1x4-40/39 (L34,43,30,71,31, 62,70,90,74, 98,115,14,08), 4x1-20/70(all-L14,08), 2dct, 3dcr; type 271, 285, 291 radars, type 123A, 127 sonars
		L14	Beaufort	1941		
		L26	Bedale	1942		
		L34	Bicester	1942		
		L43	Blackmore	1942		
		L30	Blankney	1941		
		L71	Calpe	1941		
		L31	Chiddingfold	1941		
		L52	Cowdray	1942		
		L62	Croome	1941		
		L08	Exmoor	1941		
		L70	Farndale	1941		
		L88	Lamerton	1941		
		L90	Ledbury	1942		
		L74	Middleton	1942		
L98	Oakley	1942				
L115	Silverton	1941				
L99	Tetcott	1941				
L122	Wheatland	1941				

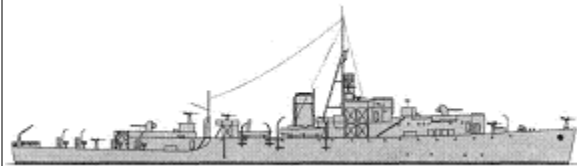

FF		L128	Wilton	1942		<p>1590t, 85.3x9.6x3.7m, 2b,2gst, 19000hp, 27kts, 168p; 2x2-102/45, 2x1-40/60(L32,09,73,18,16), 1x4-40/39(L15,75,32,09, 73,18,16), (1x4+1x1)-40/39(L12,59), 3x1-20/70(L15,75,12,59), 1x2-533TT, 4dct, 2dcr; type 272, 285, 291 radars, type 123A, 127 sonars</p>			
		L59	Zetland	1942					
	Hunt batch 3	9	L12	Albrighton			1942		
			L32	Belvoir			1942		
			L50	Bleasdale			1942		
			L09	Easton			1942		
			L15	Eggesford			1943		
			L75	Haydon			1942		
			L73	Melbreak			1942		
			L16	Stevenstone			1943		
		L18	Talybont	1943					
	Hunt batch 4	2	L76	Brecon			1942		<p>1700(L76)-1750(L79)t, 90.2x10.2x3.6m, 2b,2gst, 19000hp, 26kts, 170p; 3x2-102/45, 2x1-40/60(L76), 1x4-40/39(L76), (1x4+1x1)-40/39(L79), 2x1-20/70(L76), 4x2-20/70(L79), 1x3-533TT, 4dct, 2dcr; type 272, 285, 291 radars, type 123A, 127 sonars</p>
			L79	Brissenden			1943		
	Black Swan modified batch 1	3	U45	Wild Goose			1943		<p>1950t, 91.3x11.7x3.5m, 2b,2gst, 4300hp, 19.7kts, 192p; 3x2-102/45, 2x2-40/60, (2x2+2x1)-20/70, 8dct, 2dcr; type 275, 277, 282, 291 radars, type 123A, 177 sonars</p>
			U90	Woodcock			1943		
			U28	Wren			1943		
Black Swan modified batch 2	16	U07	Actaeon	1946		<p>1950t, 91.3x11.7x3.5m, 2b,2gst, 4300hp, 19.7kts, 192p; 3x2-102/45, (2x2+2x1)-40/60(U42,33), 2x2-40/60(U38,96,16,58,82,30), (4x2+2x1)-20/70(U60,23,39,49), 4x1-20/70(U38), (2x2+2x1)-20/70(U42,96,16,58,82,30), 2x1-20/70(U33), 1x24-178 Hedgehog ASWRL(U49,16,58,82,30), 8dct, 2dcr; type 275, 277, 282, 291 radars, type 123A, 177 sonars</p>			
		U60	Alacrity	1945					
		U16	Amethyst	1943					
		U23	Crane	1944					
		U38	Cygnet	1942					
		U58	Hart	1943					
		U39	Hind	1944					
		U82	Magpie	1943					
		U30	Mermaid	1943					
		U42	Modeste	1945					
		U64	Nereide	1946					
		U33	Opossum	1945					
		U96	Peacock	1944					
		U49	Pheasant	1943					
		U20	Snipe	1946					
			U71	Sparrow			1946		
	K255	Ballinderry	1943						
	K221	Chelmer	1943						
	K21	Dart	1943						

River	30	K257	Derg	1943
		K523	Dovey	1944
		K254	Ettrick	1943
		K92	Exe	1942
		K252	Helford	1943
		K253	Helmsdale	1943
		K235	Jed	1942
		K241	Kale	1942
		K365	Lochy	1944
		K269	Meon	1944
		K270	Nene	1943
		K219	Ness	1942
		K356	Odzani	1943
		K271	Plym	1943
		K525	Ribble	1944
		K224	Rother	1942
		K217	Swale	1942
		K367	Taff	1944
		K272	Tavy	1943
		K232	Tay	1942
K293	Tees	1943		
K239	Test	1942		
K222	Teviot	1943		
K294	Towy	1943		
K248	Waveney	1942		
K230	Wear	1942		
K371	Wye	1944		
Loch	18	K603	Loch Arkaig	1945
		K609	Loch Craggie	1944
		K425	Loch Dunvegan	1944
		K390	Loch Fada	1944
		K429	Loch Fyne	1944
		K619	Loch Glendhu	1945
		K620	Loch Gorm	1944
		K433	Loch Insh	1944
		K391	Loch Killin	1944
		K628	Loch Killisport	1945
K437	Loch Lomond	1944		
K639	Loch More	1945		
K434	Loch Quoich	1945		



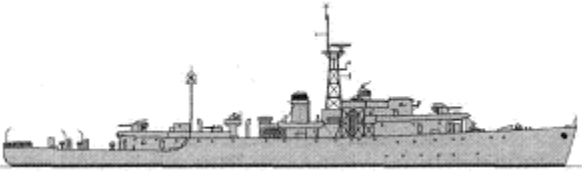
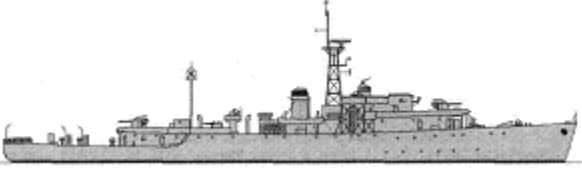

2180t, 91.8x11.2x3.9m, 2b,2vte(all-K221,254,253)-2b,2gst(K221,254,253), 5500(all-K221,254,253)-6500(K221,254,253)hp, 20(all-K221,254,253)-21(K221,254,253)kts, 140p; 2x1-102/40(all-K269,248), 6x1-40/60(K255,221,21,257, 523,254,92,365,270, 356,271,525,224, 217,272,293,239, 294,230,371), 4x1-40/60(K252,235,241, 219,232,222), 5x1-40/60(K367), 3x1-40/60(K269,248), 4x1-20/70(K269,248), 1x24-178 Hedgehog ASWRL(all-K253,269,248), 2x3-305 Squid ASWRL(K253), 8dct, 2dcr; type 277, 291 radars, sonars

2260t, 93.6x11.8x3.8m, 2b,2vte(all-K603,655)-2b,2gst(K603,655), 5500(all-K603,655)-6000(K603,655)hp, 19.5(all-K603,655)-20(K603,655)kts, 177p; 1x1-102/45, 2x1-40/60(K609,619), 1x4-40/39, (4x2+2x1)-20/70(all-K609,619), 2x1-20/70(K609,619), 2x3-305 Squid ASWRL, 2dct, 1dcr; type 277, 291 radars, sonars

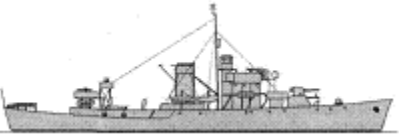
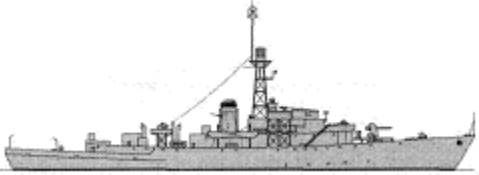
			K645	Loch Ruthven	1944		
			K648	Loch Scavaig	1944		
			K431	Loch Tarbert	1945		
			K655	Loch Tralaig	1945		
			K658	Loch Veyatie	1946		
	Bay	19	K606	Bigbury Bay	1945		2420t, 93.7x11.8x3.9m, 2b,2vte, 5500hp, 19.5kts, 177p; 2x2-102/45, 2x2-40/60(K606,615), (2x2+2x1)-40/60(K622,630,600,651, 624,627,608,650), (2x2+4x1)-40/60(K636,644,634, 604,605,633, 435,423,616), 4x2-20/70(K606,615), (2x2+2x1)-20/70(K622,630,600,651, 624,627,608,650), 2x1-20/70(K636,644,634, 604,605,633, 435,423,616), 1x24-178 Hedgehog ASWRL, 4dct, 2dcr; type 276, 285, 291 radars, sonars
			K622	Burghead Bay	1945		
			K630	Cardigan Bay	1945		
			K636	Carnarvon Bay	1945		
			K644	Cawsand Bay	1945		
			K435	Enard Bay	1946		
			K423	Largo Bay	1946		
			K624	Morecambe Bay	1949		
			K627	Mounts Bay	1946		
			K608	Padstow Bay	1946		
			K650	Porlock Bay	1946		
			K634	St. Austell Bay	1945		
			K600	St. Brides Bay	1945		
			K604	Start Bay	1945		
			K605	Tremadoc Bay	1945		
			K651	Veryan Bay	1945		
			K633	Whitesand Bay	1945		
			K615	Widemouth Bay	1945		
			K616	Wigtown Bay	1946		
	Surprise	2	K647	Alert	1946		2420t, 93.7x11.8x3.9m, 2b,2vte, 5500hp, 19.5kts, 177p; 1x2-102/45, 2x1-40/60; type 276, 285, 291 radars, sonars
			K436	Surprise	1945		
	Shearwater	1	K89	Guillemot	1939		745t, 71.1x7.8x2.7m, 2b,2gst, 3600hp, 20kts, 60p; 1x1-102/45, 2x1-20/70, 4dct, 2dcr
	Flower	4	K27	Honeysuckle	1940		1170(K27,144)-1280(K182,172)t, 62.5x10.1x4.8m, 2b,1vte, 2750hp, 16.5kts, 109p; 1x1-102/45, (2x2+2x1)-20/70, 1x24-178 Hedgehog ASWRL, 4dct, 2dcr
			K144	Meadowsweet	1942		
			K182	Bittersweet	1941		
			K172	Trillium	1940		
	Flower modified	2	K385	Arabis	1944		1370t, 62.5x10.1x4.4m, 2b,1vte, 2750hp, 16.5kts, 109p; 1x1-102/45, (2x2+2x1)-20/70, 1x24-178 Hedgehog ASWRL, 4dct, 2dcr; type 276, 291
			K403	Arbutus	1944		

FFL	Castle	24				radars, sonar	
			K689	Allington Castle	1944		1630t, 76.8x11.2x4.2m, 2b,1vte, 16.5kts, 120p; 1x1-102/40, (2x2+4x1)-20/70, 1x3-305 Squid ASWRL, 2dct, 1dcr; type 276, 291 radars, sonars
			K405	Alnwick Castle	1944		
			K386	Amberley Castle	1944		
			K412	Bamborough Castle	1944		
			K387	Berkeley Castle	1943		
			K690	Caistor Castle	1944		
			K379	Carisbrooke Castle	1943		
			K388	Dumbarton Castle	1944		
			K413	Farnham Castle	1945		
			K383	Flint Castle	1943		
			K355	Hadleigh Castle	1943		
			K529	Hedingham Castle	1945		
			K420	Kenilworth Castle	1943		
			K389	Knarborough Castle	1944		
			K691	Lancaster Castle	1944		
			K397	Launceston Castle	1944		
			K384	Leeds Castle	1944		
			K693	Morpeth Castle	1944		
			K530	Oakham Castle	1944		
			K692	Oxford Castle	1944		
			K449	Pevensey Castle	1944		
			K362	Portchester Castle	1943		
			K372	Rushen Castle	1944		
K399	Tintagel Castle	1944					

PATROL AND COASTAL COMBATANTS





MTB31	1	MTB1002	-	1944		47t, 22.3x5.9x1.3m, 3pe, 4200hp, 37kts, 13p; 1x2-20/70, 2-450TT, 2dc; radar
MTB412	6	MTB467	-	1944		53t, 21.9x6.3x1.4m, 3pe, 4050hp, 38kts, 17p; 1x1-114/19(MTB1509), 1x1-57/43(MTB467,1505-1508), 1x2-20/70, 2-450TT, 2dc; type 291 radar
		FPB1505	Proud Fusilier	1945		
		FPB1506	Proud Grenadier	1945		
		FPB1507	Proud Guardsman	1945		
		FPB1508	Proud Highlander	1945		
		FPB1509	Proud Knight	1946		
		MTB602		1942		
		MTB609		1942		
		MTB610		1942		
		MTB616		1942		
		MTB617		1942		
		MTB621		1942		
		MTB624		1942		
		MTB714		1943		
		MTB724		1943		
		MTB725		1944		
		MTB726		1944		
		MTB727		1944		
		MTB730		1944		
		MTB3001		1944		
		MTB735		1944		
		MTB738		1943		
		MTB3039		1944		
		MTB741		1944		
		MTB743		1944		
		MTB746		1944		
		MTB747		1944		
		MTB748		1944		
		MTB3002		1944		
		MTB751		1944		
		MTB753		1944		
		MTB754		1944		
		MTB755		1944		

PT	MTB601	65	MTB756	1944
			MTB757	1944
			MTB5031	1944
			MTB759	1944
			MTB760	1944
			MTB761	1944
			MTB763	1944
			MTB765	1944
			MTB766	1944
			MTB768	1944
			MTB769	1944
			MTB770	1944
			MTB771	1944
			MTB772	1944
			MTB775	1944
			MTB777	1944
			MTB778	1944
			MTB5032	1944
			MTB5001	1945
			MTB781	1944
			MTB5033	1945
			MTB788	1945
			MTB5003	1945
			MTB5035	1945
			MTB5036	1944
			MTB5037	1944
			MTB796	1944
			MTB5002	1944
			MTB5004	1945
			MTB5005	1944
			MTB5007	1945
			MTB5008	1945
			MTB5009	1945
			MTB3050	1945
			MTB3053	1945
MTB5015	1945			
MTB5020	1944			
MTB5023				
MTB5511	1944			
MTB5512	1944			
MTB5513	1944			



118t, 35.1x6.5x1.5m, 4pe, 4800hp, 29kts, 30p; 1x1-114/19(MTB5007,5008), 2x1-57/43(MTB714-796,5003-5005,5009-5020), 1x1-57/43(MTB5007,5008), 1x1-40/39(MTB602-624), 1x2-20/70, 2x2-12.7/62, 2-533TT(MTB602-724,5003-5020), 4-450TT(MTB725-796), 2dc; type 286U radar

113t, 35.7x6.8x1.3m, 3pe, 3600(MTB5511-5513)-4050(MTB5514-

MTB511	8	MTB5514		1945		5518)hp, 31(MTB5511-5513)-33(MTB5514-5518)kts, 30p; 1x1-114/19(MTB5514,5517,5518), 2x1-57/43(MTB5511-5513,5515,5516), 1x1-57/43(MTB5514,5517,5518), (1x2+2x1)-20/70, 4-450TT, 2dc; type 291 radar	
		MTB5515		1945			
		MTB5516		1945			
		MTB5517		1946			
		MTB5518		1946			
P5208	1	FPB5212		1944		122t, 34.9x5.1x1.5m, 3d, 9000hp, 39kts, 15p; 1x1-40/60, 3x1-20/65, 2-533TT	
MTB538	1	FPB1601		1948	No picture	45t, 22.6x6.2x1.8m, 3pe, 4050hp, 40kts, 15p; 1x2-20/70, 4-450TT or 1x1-114/19; type 291 radar	
MTB539	1	FPB1602		1948	No picture	50t, 22.9x6.0x1.7m, 3pe, 4050hp, 42kts, 16p; 1x2-20/70, 4-450TT or 1x1-114/19; type 291 radar	
PG	SGB1	1	S307	Grey Goose	1942		255t, 44.4x7.1x1.7m, 1b,2gst, 8000hp, 30kts, 27p; (1x2+2x1)-20/70; type 286 radar
YP	Fairmile B	53	ML2154-2156, 2196, 2217, 2220-2223, 2237, 2248, 2250, 2337, 2338, 2342, 2357, 2360, 2461, 2462, 2489, 2491, 2493, 2564, 2567-2569, 2571, 2575-2577, 2581-2583, 2585, 2586, 2592, 2593, 2595, 2840, 2866, 2869, 2882, 2886, 2889, 2901, 2906, 2912, 2919, 2921 RML512, 515, 529, 716		1940 -		86t, 34.8x5.6x1.5m, 2pe, 1200hp, 18kts, 16p; 1x1-47/40, (1x2+1x1)-20/70, 2dct, 2dcr; type 291 radar, sonar
	HDML	39	SDML1322, 1323, 1326-1329, 1391, 3503, 3505-3508, 3510-3514, 3516 SML322, 324-327, 352, 1197-1204 MSU1 ASL7 Gannet, ASL14 Peregrine		1940 -		54t, 22.0x4.8x1.4m, 2d, 260-480hp, 11-12.5kts, 10p; 2x1-20/70, 2dcr; type 291 radar

COMMAND

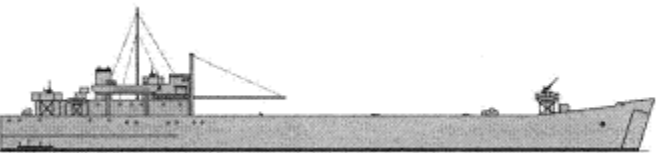
LSTQ	LST(3)	2	LST(Q)1	Ben Nevis	1945		4980t, 105.9x16.8x3.8m, 2b,2vte, 5500hp, 13.5kts, 111p; 2x2-40/60, (2x2+2x1)-20/70; 5 LCA, 170troops; radar
			LST(Q)2	Ben Lomond	1945		

AMPHIBIOUS

LSC	Empire Charmain	1		Empire Charmain	1942	No picture	7512t, 132.1x20.4x8.1m, 1d, 2580hp, 11.5kts; 1x1-102/50, 1x1-76/40, 6x1-20/70; 21 LCM(1), 323troops; radar
			LST3003	Anzio	1945		
			LST3006	Tromso	1945		
			LST3010	Attacker	1945		
			LST3015	Battler	1945		
			LST3016	Dieppe	1945		
			LST3019	Vaagso	1944		
			LST3025	Bruizer	1945		
			LST3026	Charger	1945		
			LST3027	Lofoten	1945		

LST	LST(3)	35	LST3029	Chaser	1945		4980t, 105.9x16.8x3.8m, 2b,2vte, 5500hp, 13.5kts, 111p; 2x2-40/60, (2x2+2x1)-20/70; 5 LCA, 1 LCT(6), 20 tanks, 14 trucks, 170troops; radar
			LST3031	Sultan	1945		
			LST3033		1945		
			LST3036	Puncher	1945		
			LST3038	Fighter	1945		
			LST3041		1945		
			LST3042	Hunter	1945		
			LST3043	Messina	1945		
			LST3044	Narvik	1946		
			LST3504	Pursuer	1945		
			LST3505	Ravager	1945		
			LST3507		1945		
			LST3510	Slinger	1945		
			LST3511	Reggio	1945		
			LST3512		1945		
			LST3513	Salerno	1945		
			LST3515	Stalker	1945		
			LST3516	Striker	1945		
			LST3517	St. Nazaire	1945		
			LST3518	Sulva	1945		
LST3520	Thruster	1945					
LST3522	Tracker	1945					
LST3523	Trouncer	1945					
LST3524	Trumpeter	1945					
LST3525	Walcheren	1945					
LST3532	Zeebrugge	1945					
LPA	-	1		Keren	1930	No picture	9880t, 148.3x19.6x8.2m, 2gst, 12000hp, 17kts; 1x1-152/45, 1x1-76/45, 12x1-20/70; 9 LCA, 1 LCS(M), 2 LCPL, 2 LCM, 1296 troops; radar
	LCT(2)	1	LCT151		1941		460t, 48.8x9.5x2.1m, 3d, 1380hp, 11kts, 12p; 2x1-20/70; 7 tanks
	LCT(3)	4	LCT(E)318		1942		640t, 58.1x9.5x2.0m, 2d(LCT(E)318,LCT474)-2pe(LCT7021,7027), 920(LCT(E)318,LCT474)-1000(LCT7021,7027)hp, 10.5(LCT(E)318,LCT474)-11.5(LCT7021,7027)kts, 12p; 2x1-20/70; 11 tanks
LCT474				1944			
LCT7021				1944			
LCT7027				1944			
	LCT(4)	10	LCT565		1943		640t, 57.1x11.8x1.4m, 2d, 920hp, 10kts, 12p; 2x1-20/70; 9 tanks
LCT668				1943			
LCT796				1943			
LCT895				1943			
LCT1213				1944			
LCT1268				1944			
LCT1274		1944					

LCT1283	1945
LCT1302	1945
LCT1312	1944
LCT4001	1945
LCT4002	1945
LCT4025	1945
LCT4027	1946
LCT4028	1946
LCT4037	1945
LCT4038	1945
LCT4039	1945
LCT4040	1945
LCT4041	1945
LCT4042	1945
LCT4043	1945
LCT4044	1945
LCT4045	1945
LCT4046	1945
LCT4049	1945
LCT4050	1945
LCT4051	1945
LCT4052	1945
LCT4053	1945
LCT4054	1945
LCT4055	1945
LCT4056	1945
LCT4057	1945
LCT4058	1945
LCT4059	1945
LCT4060	1945
LCT4061	1946
LCT4062	1946
LCT4063	1946
LCT4064	1946
LCT4065	1946
LCT4066	1946
LCT4067	1946
LCT4068	1946
LCT4069	1946
LCT4070	1946
LCT4071	1946

LCU

LCT(8)

107

LCT4072		1946
LCT4073		1946
LCT4074		1946
LCT4075		1946
LCT4076		1946
LCT4077		1946
LCT4078		1946
LCT4079		1946
LCT4080		1946
LCT4081		1946
LCT4082		1946
LCT4083		1946
LCT4084		1946
LCT4085		1946
LCT4086		1946
LCT4088		1946
LCT4089		1946
LCT4090		1946
LCT4091		1946
LCT4092		1946
LCT4093		1946
LCT4094		1946
LCT4095		1946
LCT4096		1946
LCT4097		1946
LCT4098		1946
LCT4099		1946
LCT4100		1946
LCT4101		1946
LCT4102		1946
LCT4103		1946
LCT4104		1946
LCT4105		1946
LCT4128		1946
LCT4129		1946
LCT4130		1946
LCT4131		1946
LCT4132		1946
LCT4133		1946
LCT4134		1946







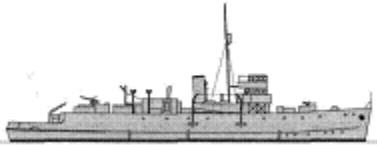

810t, 68.6x11.6x1.5m, 2d, 1760hp, 11.9kts, 13p; 3x1-20/70; 8 tanks, 42 troops; radar

			LCT4135		1946		
			LCT4148		1946		
			LCT4149		1946		
			LCT4150		1946		
			LCT4151		1946		
			LCT4152		1946		
			LCT4153		1946		
			LCT4154		1946		
			LCT4155		1946		
			LCT4156		1946		
			LCT4157		1947		
			LCT4158		1947		
			LCT4159		1947		
			LCT4160		1947		
			LCT4161		1947		
			LCT4162		1947		
			LCT4163		1947		
			LCT4164		1947		
			LCT4165		1947		
			LCT4166		1947		
			LCT4167		1947		
			LCT4168		1947		
			LCT4169		1947		
			LCT4170		1947		
			LCT4171		1947		
			LCT4172		1947		
			LCT4173		1947		
			LCT4174		1947		
			LCT4175		1947		
LC	LCA	286			1940-1944		12t, 12.6x3.1x0.7m, 2pe, 130hp, 8kts, 4p; 2x1-51/11mortars; 40 troops
	LCP(L)	10			1941-1943		8t, 11.3x3.4x1.1m, 1pe, 150-225hp, 10-12kts, 3p; 25 troops or 1 vehicle
	LCM(7)	51			1943-1944		63t, 18.4x4.9x1.1m, 2d, 290hp, 11kts, 6p; 1x2-12.7/62; 1 tank or 100 troops

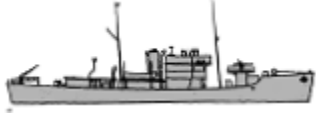
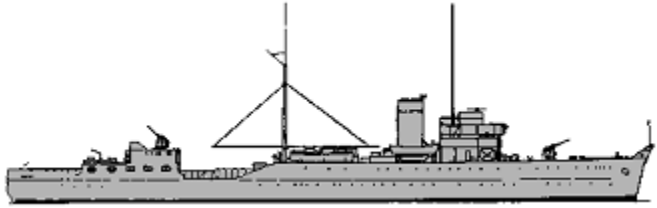
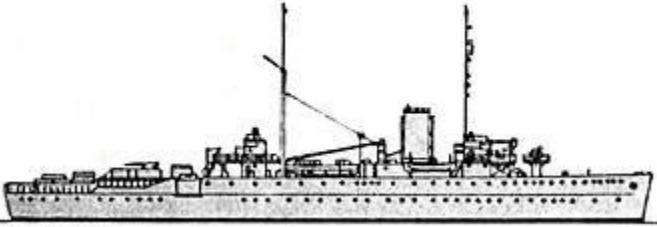
MINE WARFARE AND MINE COUNTERMEASURES

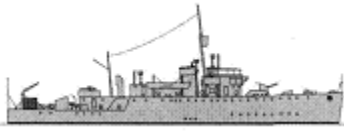
	Plover	1		Plover	1937		1020t, 59.5x11.4x3.1m, 2b,2vte, 1400hp, 14.7kts, 69p; 1x1-20/70, 100mines; radar
--	--------	---	--	--------	------	--	--

ML	Linnet	2		Linnet	1938		498t, 49.9x8.3x2.4m, 1b,1vte, 400hp, 10.5kts, 24p; 1x1-20/70, 12mines; radar	
				Ringdove	1938			
	M1	8			Miner I	1939		346t, 33.6x8.1x2.4m, 2d, 360hp, 10kts, 32p; 1x1-20/70, 10mines; type 286 radar
					Gossamer	1940		
					Miner III	1940		
				Miner IV	1940			
				Miner V	1941			
				Miner VI	1942			
				Miner VII	1944			
				Miner VIII	1943			
Blackbird	1			Dabchik	1943		770t, 50.0x8.4x3.4m, 1b,1vte, 850hp, 12.2kts, 40p; 1x1-76/40, 3x1-20/70, mines; radar	
Corncrake	1			Redshank	1943	No picture	830t, 49.2x7.7x4.0m, 1b,1vte, 700hp, 11.2kts, 35p; 1x1-76/40, 3x1-20/70, 12mines; radar	
NL	Guardian	1		Guardian	1933		3665t, 103.0x16.2x4.2m, 2b,2gst, 6500hp, 18kts, 181p; 1x2-102/45, (4x2+6x1)-20/70, nets; radar	
	Protector	1		Protector	1936		3610t, 103.0x16.2x4.2m, 2b,2gst, 9000hp, 20kts, 190p; 1x2-102/45, (2x2+3x1)-20/70, nets; radar	
	Halcyon batch 1	2	J42	Halcyon	1934		1330t, 74.8x10.2x3.1m, 2b,2vc, 1770hp, 16.5kts, 80p; 1x1-102/45, (2x2+2x1)-20/70, 4dct, 2dcr, sweeps; radar, sonar	
			J71	Harrier	1934			
	Halcyon batch 3	1	J83	Gleaner	1938		1330t, 74.8x10.2x3.1m, 2b,2gst, 1750hp, 17kts, 80p; 1x1-102/45, (2x2+2x1)-20/70, 4dct, 2dcr, sweeps; radar, sonar	
	Bangor VTE	3	J77	Romney	1940		875t, 54.9x8.7x3.1m, 2b,2vte, 2400hp, 16.5kts, 87p; 1x1-76/45, 3x1-20/70, 4dct, 2dcr, sweeps; radar, sonar	
			J47	Sidmouth	1941			
J119			Fort York	1942				
Bangor	2	J97	Polruan	1941		780t, 53.0x8.7x3.0m, 2b,2gst, 2000hp, 16.5kts, 87p; 1x1-76/45, 3x1-20/70, 4dct, 2dcr, sweeps; radar, sonar		

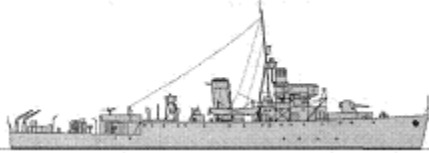
turbine						
	J19	Rothesay	1941			
Algerine turbine	22	J106	Acute	1942		1265t, 68.6x10.8x3.2m, 2b,2gst, 2000hp, 16.5kts, 138p; 1x1-102/45, 4x1-40/60(J389,390), 4x2-20/70(all-J389,390), 4dct, 2dcr, sweeps; radar, sonar
		J101	Albacore	1942		
		J305	Brave	1943		
		J230	Cadmus	1942		
		J387	Chamaeleon	1944		
		J388	Cheerful	1944		
		J214	Circe	1942		
		J216	Espiegle	1942		
		J308	Fancy	1942		
		J389	Hare	1944		
		J390	Jewel	1944		
		J227	Mutine	1943		
		J221	Onyx	1943		
		J293	Pickle	1943		
		J294	Pincher	1943		
		J295	Plucky	1943		
		J223	Ready	1943		
		J298	Recruit	1944		
		J299	Rifleman	1944		
		J225	Rinaldo	1943		
		J219	Rosario	1943		
		J226	Spanker	1943		
		J273	Bramble	1945		
		J229	Cockatrice	1943		
		J453	Fierce	1945		
		J307	Hound	1942		
		J276	Lennox	1944		
		J442	Niger	1945		
		J277	Orestes	1943		
		J297	Rattlesnake	1943		
		J384	Rowena	1944		
		J367	Stormcloud	1944		
		J382	Sylvia	1944		
		J383	Tanganyika	1944		
		J304	Waterwitch	1943		
		J385	Wave	1944		
		J386	Welcome	1945		

MSO

Algerine
VTE

50

J350	Coquette	1944
J349	Courier	1944
J376	Golden Fleece	1944
J428	Jaseur	1944
J433	Laertes	1945
J377	Lioness	1944
J379	Lysander	1944
J435	Maenad	1944
J436	Magicienne	1945
J437	Mameluke	1945
J438	Mandate	1945
J380	Mariner	1945
J381	Marmion	1945
J443	Marvel	1945
J360	Mary Rose	1945
J289	Melita	1943
J444	Michael	1945
J329	Moon	1944
J454	Myrmidon	1945
J455	Mystic	1945
J456	Nerissa	1945
J290	Octavia	1944
J462	Orcadia	1945
J463	Ossory	1945
J446	Pluto	1945
J447	Polaris	1945
J325	Providence	1944
J448	Pyrrhus	1945
J449	Romola	1945
J333	Seabear	1944
J354	Serene	1944
J300	Skipjack	1944
J302	Thisbe	1944
J303	Truelove	1944
J356	Welfare	1944
T241	Annet	1943
T273	Bardsey	1943
T294	Bern	1942
T208	Damsay	1942
T297	Earraid	1942



1325t, 68.6x10.8x3.3m, 2b,2vte, 2400hp, 16.5kts, 138p; 1x1-102/45, 4x1-40/60(J349,428,377,354,385,386), 4x2-20/70(all-J349,428,377,354,385,386), 4dct, 2dcr, sweeps; radar, sonar





Isles	25	T202	Fetlar	1942		770t, 50.0x8.4x3.4m, 1b,1vte, 850hp, 12.2kts, 40p; 1x1-76/40, 3x1-20/70, 4dct, 2dcr, sweeps; radar, sonar
		T354	Flatholm	1943		
		T342	Foulness	1943		
		T288	Gateshead	1943		
		T387	Gorregan	1944		
		T422	Imersay	1944		
		T272	Lundy	1943		
		T450	Orsay	1945		
		T429	Ronay	1945		
		T424	Sandray	1944		
		T426	Shillay	1945		
		T163	Skye	1942		
		T356	Steepholm	1943		
		T427	Sursay	1945		
		T452	Tahay	1945		
		T81	Tocogay	1945		
		T431	Trodday	1945		
		T432	Vaceasay	1945		
		T434	Vallay	1945		
		T341	Wiay	1945		
		MMS35		1941		
		MMS36		1941		
		MMS40		1941		
		MMS42		1941		
		MMS46		1941		
		MMS47		1941		
		MMS56		1941		
		MMS57		1942		
		MMS69		1942		
		MMS79		1941		
		MMS83		1941		
		MMS84		1942		
		MMS86		1942		
		MMS103		1942		
		MMS109		1942		
		MMS110		1942		
		MMS144		1944		
		MMS181		1942		
		MMS217		1942		
		MMS222	Amber	1946		
		MMS223	Jade	1946		

MSC	MMS1	42				295t, 36.4x7.1x2.7m, 1d, 375-500hp, 10-11kts, 20p; 2x1-20/70, sweeps; radar	
			MMS224				1942
			MMS228				1942
			MMS233	St. David			1942
			MMS236				1942
			MMS261	Venturer			1943
			MMS263				1943
			MMS271				1943
			MMS272				1943
			MMS275	Neptune			1943
			MMS283				1943
			MMS285				1943
			MMS286				1943
			MMS288				1943
			MMS289				1943
			MMS290				1943
			MMS291				1943
			MMS294				1943
			MMS296				1943
			MMS297				1943
MMS301		1944					
MMS307		1944					
MMS1001	8	MMS1002		1944		430t, 42.7x8.5x3.2m, 1d, 500hp, 10kts, 21p; 2x2-20/70, sweeps; radar	
		MMS1003		1943			
		MMS1004		1943			
		MMS1011		1943			
		MMS1035		1943			
		MMS1060		1945			
		MMS1061		1945			
		MMS1089		1945			

[home](#)[World navies yesterday](#)[1950](#)

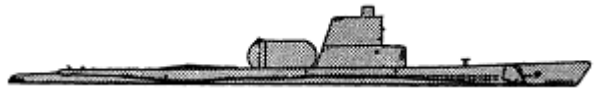
United States of America 01 January 1950

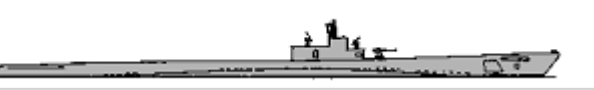
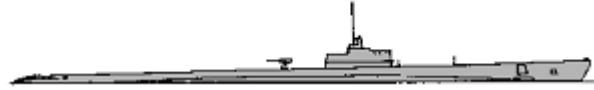
SUBMARINES

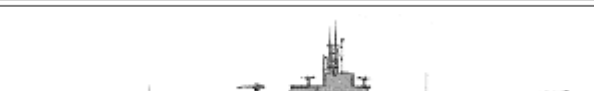
SSG	Balao SSG	2	AGSS337	Carbonero	1945		1525/2400t, 95.1x8.3x4.7m, 4dg/4em(2), 5400/2740hp, 20/8.7kts, 84p, 120m; 2 Loon CruM launchers (2 LTV-N-2), 10-533TT(24); SS, ST, SV-4 radars, BQR-2, BQS-2, JT sonars	
			SSG348	Cusk	1946			
	Porpoise	2	SS172	Porpoise	1935		1316/1934t, 91.8x7.6x4.3m, 4dg,2em, 4300/2085hp, 19/10kts, 54p, 75m; 1x1-76/50, 2x1-20/70, 8-533TT(18), SD radar, sonar	
			SS173	Pike	1935			
	Shark	1	SS175	Tarpon	1936		1315/1968t, 90.8x7.6x4.6m, 4dg,2em, 4300/2085hp, 19.5/8kts, 54p, 75m; 1x1-76/50, 2x1-20/70, 8-533T(18), SD radar, sonar	
	Perch	2	SS178	Permit	1937		1330/1997t, 91.6x7.7x4.6m, 4dg,2em, 4300/2366hp, 19.2/8kts, 54p, 75m; 1x1-76/50, 2x1-20/70, 8-533TT(18)(SS178), 6-533TT(16)(SS179), SD radar, sonar	
			SS179	Plunger	1936			
	Salmon	1	SS183	Seal	1938		1449/2210t, 93.9x8.0x4.7m, 4d/4em(2), 5500/2660hp, 21/9kts, 59p, 75m; 1x1-127/25, 2x1-20/70, 8-533TT(24), SD radar, sonar	
	Tambor	3	SS198	Tambor	1940		1475/2370t, 93.6x8.3x4.6m, 4d/4em(2), 5400/2740hp, 20/8.7kts, 60p, 75m; 1x1-127/25, 1x1-40/60, 1x1-20/70, 10-533TT(24), SD radar, sonar	
			SS199	Tautog	1940			
			SS206	Gar	1941			
				SS212	Gato	1941		
				SS213	Greenling	1942		
				SS214	Grouper	1942		
				SS217	Guardfish	1942		
			SS220	Barb	1942			
			SS221	Blackfish	1942			
			SS222	Bluefish	1943			
			SS224	Cod	1943			
			SS225	Cero	1943			
			SS228	Drum	1941			
			SS229	Flying Fish	1941			

Gato

56

SS230	Finback	1942
SS231	Haddock	1942
SS234	Kingfish	1942
SS235	Shad	1942
SS236	Silversides	1941
SS239	Whale	1942
SS240	Angler	1943
SS241	Bashaw	1943
SS242	Bluegill	1943
SS243	Bream	1944
SS244	Cavalla	1944
SS245	Cobia	1944
SS246	Croaker	1944
SS247	Dace	1943
SS249	Flasher	1943
SS251	Flounder	1943
SS252	Gabilan	1943
SS253	Gunnel	1942
SS254	Gurnard	1942
SS255	Haddo	1942
SS256	Hake	1942
SS258	Hoe	1942
SS259	Jack	1943
SS260	Lapon	1943
SS261	Mingo	1943
SS262	Muskallunge	1943
SS263	Paddle	1943
SS264	Pargo	1943
SS265	Peto	1942
SS266	Pogy	1943
SS267	Pompon	1943
SS268	Puffer	1943
SS269	Rasher	1943
SS270	Raton	1943
SS271	Ray	1943
SS272	Redfin	1943
SS274	Rock	1943
SS276	Sawfish	1942
SS280	Steelhead	1942
SS281	Sunfish	1942
SS282	Tunny	1942



1810/2410t, 95.0x8.3x4.7m, 4dg/4em(2), 5400/2740hp, 20.2/8.7kts, 60p, 90m; 1x1-127/25, 1x1-40/60, 1x1-20/70, 10-533TT(24), SS, ST, SV radars, sonar

SS283	Tinosa	1943
SS362	Guavina	1943
SS363	Guitarro	1944
SS364	Hammerhead	1944
SS285	Balao	1943
SS286	Billfish	1943
SS287	Bowfin	1943
SS288	Cabrilla	1943
SS291	Crevalle	1943
SS292	Devilfish	1944
SS293	Dragonet	1944
SS295	Hackleback	1944
SS297	Ling	1945
SS298	Lionfish	1944
SS300	Moray	1945
SS301	Roncador	1945
SS302	Sabalo	1945
SS303	Sablefish	1945
SS304	Seahorse	1943
SS307	Tilefish	1943
SS309	Aspro	1943
SS310	Batfish	1943
SS311	Archerfish	1943
SS319	Becuna	1944
SS320	Bergall	1944
SS321	Besugo	1944
SS322	Blackfin	1944
SS323	Caiman	1944
SS324	Blenny	1944
SS325	Blower	1944
SS328	Charr	1944
SS331	Bugara	1944
SS333	Bumper	1944
SS334	Cabazon	1944
SS335	Dentuda	1944
SS336	Capitaine	1945
SS338	Carp	1945
SS339	Catfish	1945
SS340	Entemedor	1945
SS341	Chivo	1945

SS



Balao

83

SS342	Chopper	1945
SS365	Hardhead	1944
SS366	Hawkbill	1944
SS367	Icefish	1944
SS368	Jallao	1944
SS370	Kraken	1944
SS372	Lambrey	1944
SS373	Lizardfish	1944
SS374	Loggerhead	1945
SS375	Macabi	1945
SS376	Mapiro	1945
SS377	Menhaden	1945
SS378	Mero	1945
SS381	Sand Lance	1943
SS382	Picuda	1943
SS383	Pampanito	1943
SS384	Parche	1943
SS385	Bang	1943
SS387	Pintado	1944
SS388	Pipefish	1944
SS389	Piranha	1944
SS390	Plaice	1944
SS391	Pomfret	1944
SS392	Sterlet	1944
SS393	Queenfish	1944
SS394	Razorback	1944
SS395	Redfish	1944
SS396	Ronquil	1944
SS397	Scabbardfish	1944
SS398	Segundo	1944
AGSS399	Sea Cat	1944
SS400	Sea Devil	1944
SS401	Sea Dog	1944
SS402	Sea Fox	1944
SS403	Atule	1944
SS404	Spikefish	1944
SS405	Sea Owl	1944
SS406	Sea Poacher	1944
SS407	Sea Robin	1944
SS408	Sennet	1944
SS409	Piper	1944

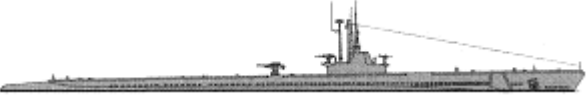

1845/2415t, 95.0x8.3x4.7m, 4dg/4em(2), 5400/2740hp, 20.2/8.7kts, 60p, 120m; 1x1-127/25, 1x1-40/60, 1x1-20/70, 10-533TT(24); SS, ST, SV radars, sonar

		<table border="1"> <tr><td>SS410</td><td>Threadfin</td><td>1944</td></tr> <tr><td>SS411</td><td>Spadefish</td><td>1944</td></tr> <tr><td>SS412</td><td>Trepang</td><td>1944</td></tr> <tr><td>SS413</td><td>Spot</td><td>1944</td></tr> <tr><td>SS414</td><td>Springer</td><td>1944</td></tr> <tr><td>SS415</td><td>Stickleback</td><td>1945</td></tr> </table>	SS410	Threadfin	1944	SS411	Spadefish	1944	SS412	Trepang	1944	SS413	Spot	1944	SS414	Springer	1944	SS415	Stickleback	1945																																
SS410	Threadfin	1944																																																		
SS411	Spadefish	1944																																																		
SS412	Trepang	1944																																																		
SS413	Spot	1944																																																		
SS414	Springer	1944																																																		
SS415	Stickleback	1945																																																		
Balao GUPPY II	9	<table border="1"> <tr><td>SS343</td><td>Clamagore</td><td>1945</td></tr> <tr><td>SS344</td><td>Cobbler</td><td>1945</td></tr> <tr><td>SS346</td><td>Corporal</td><td>1945</td></tr> <tr><td>SS347</td><td>Cubera</td><td>1945</td></tr> <tr><td>SS349</td><td>Diodon</td><td>1946</td></tr> <tr><td>SS350</td><td>Dogfish</td><td>1946</td></tr> <tr><td>SS351</td><td>Greenfish</td><td>1946</td></tr> <tr><td>SS352</td><td>Halfbeak</td><td>1946</td></tr> <tr><td>SS416</td><td>Tiru</td><td>1948</td></tr> </table>	SS343	Clamagore	1945	SS344	Cobbler	1945	SS346	Corporal	1945	SS347	Cubera	1945	SS349	Diodon	1946	SS350	Dogfish	1946	SS351	Greenfish	1946	SS352	Halfbeak	1946	SS416	Tiru	1948		1870/2440t, 93.6x8.2x5.2m, 4dg/4em(2), 4610/5400hp, 18/16kts, 82p, 120m; 10-533TT(24); SS, ST, SV radars, BQR-2, BQS-2, JT or SQR-3 sonars																					
SS343	Clamagore	1945																																																		
SS344	Cobbler	1945																																																		
SS346	Corporal	1945																																																		
SS347	Cubera	1945																																																		
SS349	Diodon	1946																																																		
SS350	Dogfish	1946																																																		
SS351	Greenfish	1946																																																		
SS352	Halfbeak	1946																																																		
SS416	Tiru	1948																																																		
Tench	16	<table border="1"> <tr><td>SS417</td><td>Tench</td><td>1944</td></tr> <tr><td>SS418</td><td>Thornback</td><td>1944</td></tr> <tr><td>SS420</td><td>Tirante</td><td>1944</td></tr> <tr><td>SS421</td><td>Trutta</td><td>1944</td></tr> <tr><td>SS422</td><td>Toro</td><td>1944</td></tr> <tr><td>SS423</td><td>Torsk</td><td>1944</td></tr> <tr><td>SS424</td><td>Quillback</td><td>1944</td></tr> <tr><td>SS435</td><td>Corsair</td><td>1946</td></tr> <tr><td>SS436</td><td>Unicorn</td><td>1946</td></tr> <tr><td>SS437</td><td>Walrus</td><td>1946</td></tr> <tr><td>SS475</td><td>Argonaut</td><td>1945</td></tr> <tr><td>SS476</td><td>Runner</td><td>1945</td></tr> <tr><td>SS477</td><td>Conger</td><td>1945</td></tr> <tr><td>SS479</td><td>Diablo</td><td>1945</td></tr> <tr><td>SS480</td><td>Medregal</td><td>1945</td></tr> <tr><td>SS488</td><td>Sarda</td><td>1946</td></tr> </table>	SS417	Tench	1944	SS418	Thornback	1944	SS420	Tirante	1944	SS421	Trutta	1944	SS422	Toro	1944	SS423	Torsk	1944	SS424	Quillback	1944	SS435	Corsair	1946	SS436	Unicorn	1946	SS437	Walrus	1946	SS475	Argonaut	1945	SS476	Runner	1945	SS477	Conger	1945	SS479	Diablo	1945	SS480	Medregal	1945	SS488	Sarda	1946		1845/2415t, 95.0x8.3x4.7m, 4dg/4em(2), 5400/2740hp, 20.2/8.7kts, 60p, 120m(SS417-437)-135m(SS475-529); 1x1-127/25(SS417-437), 2x1-127/25(SS475-529), 1x1-40/60, 1x1-20/70, 10-533TT(24)(SS417-437), 10-533TT(28)(SS475-529); SS, ST, SV radars, sonars
SS417	Tench	1944																																																		
SS418	Thornback	1944																																																		
SS420	Tirante	1944																																																		
SS421	Trutta	1944																																																		
SS422	Toro	1944																																																		
SS423	Torsk	1944																																																		
SS424	Quillback	1944																																																		
SS435	Corsair	1946																																																		
SS436	Unicorn	1946																																																		
SS437	Walrus	1946																																																		
SS475	Argonaut	1945																																																		
SS476	Runner	1945																																																		
SS477	Conger	1945																																																		
SS479	Diablo	1945																																																		
SS480	Medregal	1945																																																		
SS488	Sarda	1946																																																		
Tench GUPPY I	2	<table border="1"> <tr><td>SS484</td><td>Odax</td><td>1945</td></tr> <tr><td>SS486</td><td>Pomodone</td><td>1945</td></tr> </table>	SS484	Odax	1945	SS486	Pomodone	1945		1830/2440t, 93.6x8.2x5.2m, 4dg/4em(2), 4610/5400hp, 18/18kts, 82p, 135m; 10-533TT(24), SS, ST, SV radars, BQR-2, BQS-2, JT sonars																																										
SS484	Odax	1945																																																		
SS486	Pomodone	1945																																																		
Tench GUPPY II	10	<table border="1"> <tr><td>SS425</td><td>Trumpetfish</td><td>1946</td></tr> <tr><td>SS426</td><td>Tusk</td><td>1946</td></tr> <tr><td>SS478</td><td>Cutlass</td><td>1945</td></tr> <tr><td>SS483</td><td>Sea Leopard</td><td>1945</td></tr> <tr><td>SS485</td><td>Sirago</td><td>1945</td></tr> <tr><td>SS487</td><td>Remora</td><td>1946</td></tr> <tr><td>SS490</td><td>Volador</td><td>1948</td></tr> </table>	SS425	Trumpetfish	1946	SS426	Tusk	1946	SS478	Cutlass	1945	SS483	Sea Leopard	1945	SS485	Sirago	1945	SS487	Remora	1946	SS490	Volador	1948		1870/2440t, 93.6x8.2x5.2m, 4dg/4em(2), 4610/5400hp, 18/16kts, 82p, 135m; 10-533TT(24); SS, ST, SV radars, BQR-2, BQS-2, JT or SQR-3 sonars																											
SS425	Trumpetfish	1946																																																		
SS426	Tusk	1946																																																		
SS478	Cutlass	1945																																																		
SS483	Sea Leopard	1945																																																		
SS485	Sirago	1945																																																		
SS487	Remora	1946																																																		
SS490	Volador	1948																																																		

			SS522	Amberjack	1946		
			SS523	Grampus	1947		
			SS524	Pickrel	1949		
	Tench Fleet Snorkel	1	SS482	Irex	1945		1830/2440t, 95.0x8.3x5.2m, 4dg/4em(2), 4610/2700hp, 20/10kts, 82p, 135m; 10-533TT(24); SS, ST, SV radars, BQR-2, BQS-2, SQR-3 sonars
SSR	Balao Migraine I	1	SSR312	Burrfish	1943		1525/2410t, 95.1x8.3x4.7m, 4dg/2em(2), 4610/1750hp, 17/8kts, 120p, 120m; 1x1-40/60, 4-533TT(12); SS, SV-1, SV-2, BPS-2 radars, sonar
	Tench Migraine	2	SSR481	Requin	1945		1525/2410t, 95.1x8.3x4.7m, 4dg/2em(2), 4610/1750hp, 17/8kts, 60p, 135m; 1x1-40/60, 4-533TT(12); SS, SV-1, SV-2 radars, sonars
			SSR489	Spinax	1946		
	Tench Migraine I	1	SSR419	Tigrone	1944		1525/2410t, 95.1x8.3x4.7m, 4dg/2em(2), 4610/1750hp, 17/8kts, 60p, 120m; 1x1-40/60, 4-533TT(12); SS, SV-1, SV-2, BPS-2 radars, sonars
SSL	Balao	3	SSP313	Perch	1944		1845/2415t, 95.0x8.3x4.7m, 2dg/4em(2), 2700/2740hp, 20.2/8.7kts, 60p, 120m; 6-533TT(18), helicopter deck(SSP315); marines and vehicles; SS, ST, SV radars, sonar
			SSP315	Sealion	1944		
			SSA317	Barbero	1944		

AIRCRAFT CARRIERS

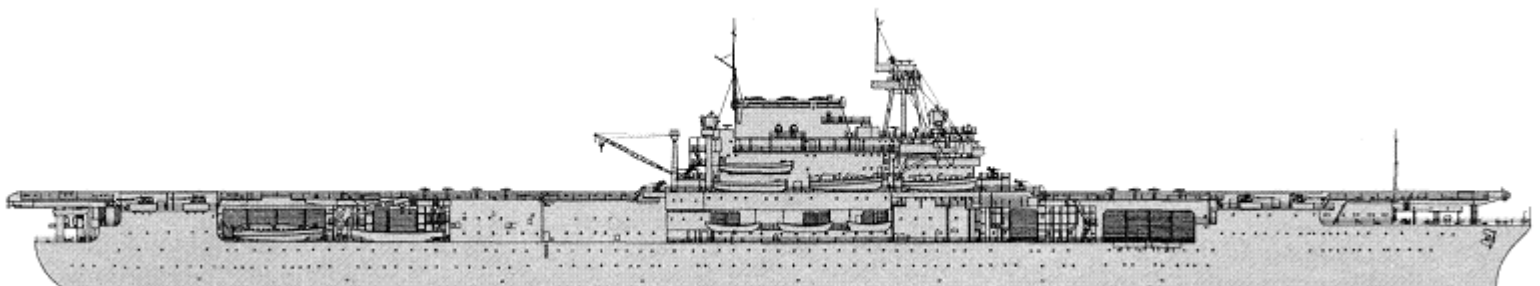
	Yorktown	1	CV6	Enterprise	1938		29882t, 251.4x33.4x7.9m, 9b,4gst, 120000hp, 32.5kts, 2175p; 102belt, 38deck, 102CT; 8x1-127/38, 10x4-40/60, 48x1-20/70, 3catapults, 96aircraft (F4U, FG, F3A, F6F, F7F, F8F, FH, FJ, F2H, F9F, F6U fighters, AD, AM, AJ attackers, TBF, TBM bombers, TBM-S, TBM-W ASW, TBF-P, F4U-P, F6F-P, F7F-P, F8F-P recon, TBM-Q, AD-Q, AM-Q ECM, AD-W EW, HO3S, HRP helicopters); SC-2, SK, SM, 2x MK 12/22 radars
			CV9	Essex	1942		34881t, 265.8(CV9-13,16-18,20,31)-270.7(CV14,15,17-19,21,32-40,45-47)x45.0x8.4m, 8b,4gst, 150000hp, 32.7kts, 2682p; 102belt, 102decks; (4x2+4x1)-127/38, 11x4-40/60(CV9, 38), 17x4-40/60(CV10,11, 16-18, 31), 10x4-40/60(CV12), 8x4-40/60(CV13), 18x4-40/60(CV14, 15, 19-21, 32, 33, 36, 37, 39, 40, 45, 47), 61x1-20/70(CV9-11), 35x1-20/70(CV12), 46x1-20/70(CV13), 35x2-20/70(CV14, 17, 21, 32, 33), 56x1-
			CV10	Yorktown	1943		
			CV11	Intrepid	1943		
			CV12	Hornet	1943		
			CV13	Franklin	1944		
			CV14	Ticonderoga	1944		
			CV15	Randolph	1944		
			CV16	Lexington	1943		
			CV17	Bunker Hill	1943		
			CV18	Wasp	1943		
			CV19	Hancock	1944		

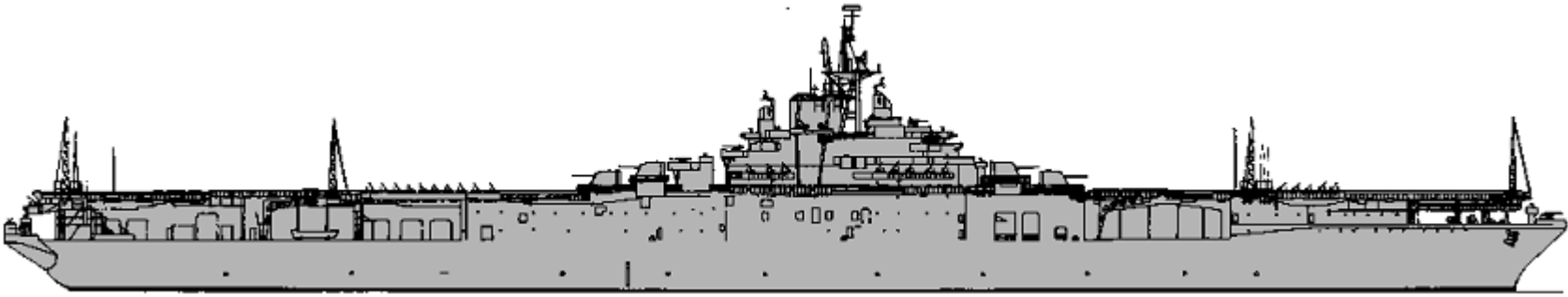
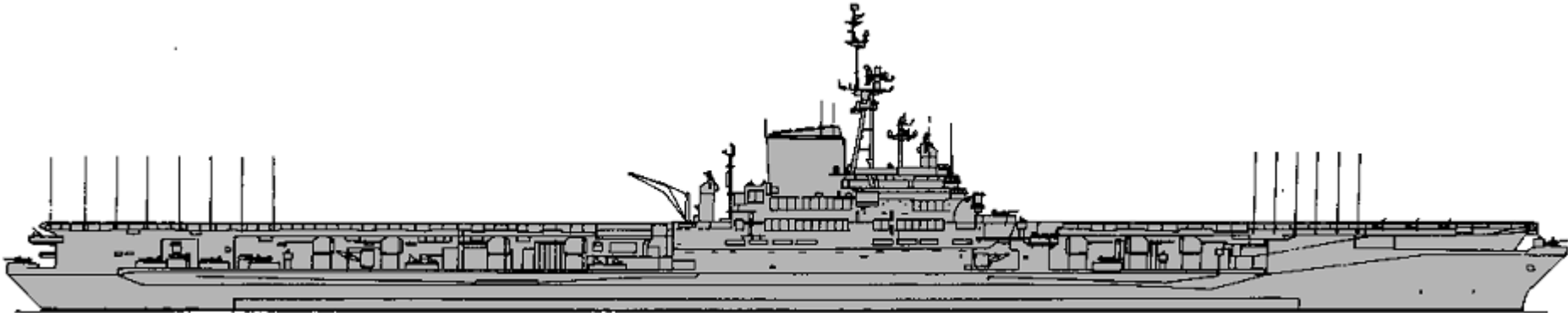
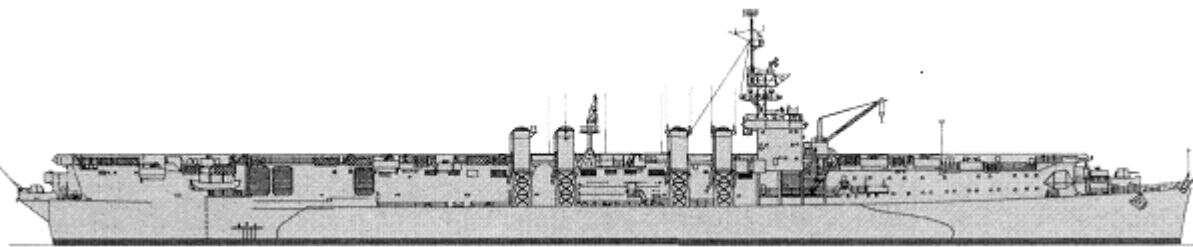
CV	Essex	23					20/70(CV15, 31), 30x2-20/70(CV16), 29x2-20/70(CV18), 59x1-20/70(CV19), 60x1-20/70(CV20), (16x2+23x1)-20/70(CV36,37,39,40, 45, 47), (53x2+7x1)-20/70(CV38), 5x4-12.7/90(CV16), 6x4-12.7/90(CV18), 2catapults, 91aircraft (F4U, FG, F3A, F6F, F7F, F8F, FH, FJ, F2H, F9F, F6U fighters, AD, AM, AJ attackers, TBF, TBM bombers, TBM-S, TBM-W ASW, TBF-P, F4U-P, F6F-P, F7F-P, F8F-P recon, TBM-Q, AD-Q, AM-Q ECM, AD-W EW, HO3S, HRP helicopters); SG, SK-2, SR, SP, 2x Mk 12/22 radars
			CV20	Bennington	1944		
			CV21	Boxer	1945		
			CV31	Bon Homme Richard	1944		
			CV32	Leyte	1946		
			CV33	Kearsarge	1946		
			CV36	Antietam	1945		
			CV37	Princeton	1945		
			CV38	Shangri La	1944		
			CV39	Lake Champlain	1945		
			CV40	Tarawa	1945		
			CV45	Valley Forge	1946		
			CV47	Philippine Sea	1946		
CV	Midway	3	CVB41	Midway	1945		59901t, 295.0x41.5x10.5m, 12b,4gst, 212000hp, 33kts, 4104p; 193/178belt, 191deck; 18x1-127/54(CVB41,42), 14x1-127/54(CVB43), 10x2-76/50, 137aircraft (F4U, FG, F3A, F6F, F7F, F8F, FH, FJ, F2H, F9F, F6U fighters, AD, AM, AJ attackers, TBF, TBM bombers, TBM-S, TBM-W ASW, TBF-P, F4U-P, F6F-P, F7F-P, F8F-P recon, TBM-Q, AD-Q, AM-Q ECM, AD-W EW, HO3S, HRP helicopters); SK-2(CVB41), SR-2, SR-3(CVB42,43), SX, 2x SG, 4x Mk 25 radars
			CVB42	Franklin D. Roosevelt	1945		
			CVB43	Coral Sea	1947		
CVL	Independence	7	CVL24	Belleau Wood	1943		14751t, 189.7x33.3x7.4m, 4b,4gst, 100000hp, 31.6kts, 1569p; 127belt, 51deck; (2x4+10x2)-40/60(CVL24,29), 9x2-40/60(CVL25-28,30), 4x1-20/70(CVL24,29), 5x2-20/70(CVL25,27,28), 8x2-20/70(CVL26), 22x1-20/70(CVL30), 1catapult, 30aircraft(F4U, FG, F3A, F6F, F7F, F8F, FH, FJ, F2H, F9F, F6U fighters, AD, AM, AJ attackers, TBF, TBM bombers, TBM-S, TBM-W ASW, TBF-P, F4U-P, F6F-P, F7F-P, F8F-P recon, TBM-Q, AD-Q, AM-Q ECM, AD-W EW, HO3S, HRP helicopters); SK, SP, SG radars
			CVL25	Cowpens	1943		
			CVL26	Monterey	1943		
			CVL27	Langley	1943		
			CVL28	Cabot	1943		
			CVL29	Bataan	1943		
			CVL30	San Jacinto	1943		

	Saipan	2	CVL48	Saipan	1946		18750t, 208.4x32.9x8.2m, 4b,4gst, 120000hp, 33kts, 1821p; 102belt, 64deck; (5x4+10x2)-40/60, 16x2-20/70, 1 catapult, 48aircraft (F4U, FG, F3A, F6F, F7F, F8F, FH, FJ, F2H, F9F, F6U fighters, AD, AM, AJ attackers, TBF, TBM bombers, TBM-S, TBM-W ASW, TBF-P, F4U-P, F6F-P, F7F-P, F8F-P recon, TBM-Q, AD-Q, AM-Q ECM, AD-W EW, HO3S, HRP helicopters); SK-2, SP radars	
			CVL49	Wright	1947			
	Bogue	10	CVE9	Bogue	1942		13891t, 151.1x34.0x7.1m, 2b,1gst, 8500hp, 16.5kts, 890p; 2x1-127/38, 10x2-40/60, 27x1-20/70(CVE9-25), (10x2+7x1)-20/70(CVE31), 1catapult, 28aircraft(F4U, FG, F3A, F6F, F7F, F8F, FH, FJ, F2H, F9F, F6U fighters, AD, AM, AJ attackers, TBF, TBM bombers, TBM-S, TBM-W ASW, TBF-P, F4U-P, F6F-P, F7F-P, F8F-P recon, TBM-Q, AD-Q, AM-Q ECM, AD-W EW, HO3S, HRP helicopters); SC, SG radars	
			CVE11	Card	1942			
			CVE12	Copahee	1942			
			CVE13	Core	1942			
			CVE16	Nassau	1942			
			CVE18	Altamaha	1942			
			CVE20	Barnes	1943			
			CVE23	Breton	1943			
			CVE25	Croatan	1943			
			CVE31	Prince William	1943			
	Sangamon	3	CVE27	Suwanee	1940		23875t, 168.6x32.1x9.3m, 4b,2gst, 13500hp, 18kts, 1080p; 2x1-127/51, (2x4+10x2)-40/60, 21x1-20/70(CVE27,28), 19x1-20/70(CVE29), 2catapults, 31 aircraft (F4U, FG, F3A, F6F, F7F, F8F, FH, FJ, F2H, F9F, F6U fighters, AD, AM, AJ attackers, TBF, TBM bombers, TBM-S, TBM-W ASW, TBF-P, F4U-P, F6F-P, F7F-P, F8F-P recon, TBM-Q, AD-Q, AM-Q ECM, AD-W EW, HO3S, HRP helicopters); SC-2, SG radars	
			CVE28	Chenango	1939			
			CVE29	Santee	1939			
			CVE57	Anzio	1943			
			CVE58	Corregidor	1943			
			CVE59	Mission Bay	1943			
			CVE60	Guadalcanal	1943			
			CVE61	Manila Bay	1943			
			CVE62	Natoma Bay	1943			
			CVE64	Tripoli	1943			
			CVE66	White Plains	1943			
			CVE69	Kasaan Bay	1943			
			CVE70	Fanshaw Bay	1943			
			CVE74	Nehenta Bay	1944			

CVE Casablanca

34

CVE75	Hoggatt Bay	1944
CVE76	Kadashan Bay	1944
CVE77	Marcus Island	1944
CVE78	Savo Island	1944
CVE80	Petrof Bay	1944
CVE81	Rudyard Bay	1944
CVE82	Saginaw Bay	1944
CVE83	Sargent Bay	1944
CVE84	Shamrock Bay	1944
CVE85	Shipley Bay	1944
CVE86	Sitkoh Bay	1944
CVE87	Steamer Bay	1944
CVE88	Cape Esperance	1944
CVE89	Takanis Bay	1944
CVE90	Thetis Bay	1944
CVE91	Makassar Strait	1944
CVE92	Windham Bay	1944
CVE94	Lunga Point	1944
CVE97	Hollandia	1944
CVE98	Kwajalein	1944
CVE100	Bougainville	1944
CVE101	Matanikau	1944
CVE104	Munda	1944

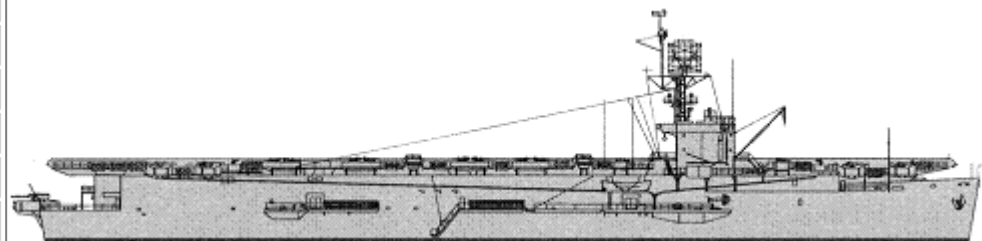

10902t, 156.1x32.9x6.3m, 4b,2vqe, 9000hp, 19kts, 860p; 1x1-127/38, 8x2-40/60, 20x1-20/70, 1catapult, 27aircraft(F4U, FG, F3A, F6F, F7F, F8F, FH, FJ, F2H, F9F, F6U fighters, AD, AM, AJ attackers, TBF, TBM bombers, TBM-S, TBM-W ASW, TBF-P, F4U-P, F6F-P, F7F-P, F8F-P recon, TBM-Q, AD-Q, AM-Q ECM, AD-W EW, HO3S, HRP helicopters); SG, SK radars

Commencement Bay

19

CVE105	Commencement Bay	1944
CVE106	Block Island	1944
CVE107	Gilbert Islands	1945
CVE108	Kula Gulf	1945
CVE109	Cape Gloucester	1945
CVE110	Salerno Bay	1945
CVE111	Vella Gulf	1945
CVE112	Siboney	1945
CVE113	Puget Sound	1945
CVE114	Rendova	1945
CVE115	Bairoko	1945
CVE116	Badoeng Strait	1945
CVE117	Saidor	1945
CVE118	Sicily	1946
CVE119	Point Cruz	1945

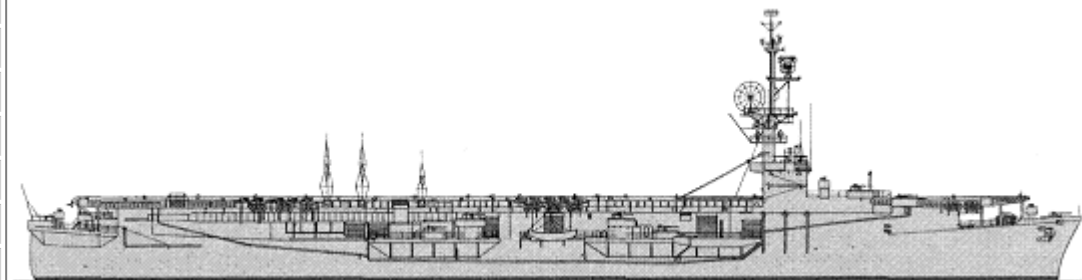

21397t, 169.9x32.1x8.5m, 4b,2gst, 16000hp, 19kts, 1066p; 2x1-127/38, (3x4+12x2)-40/60, 20x1-20/70, 2catapults, 33aircraft(F4U, FG, F3A, F6F, F7F, F8F, FH, FJ, F2H, F9F, F6U fighters, AD, AM, AJ attackers, TBF, TBM bombers, TBM-S, TBM-W ASW, TBF-P, F4U-P, F6F-P, F7F-P, F8F-P recon, TBM-Q, AD-Q, AM-Q ECM, AD-W EW, HO3S, HRP helicopters); SG, SK-2, SP radars

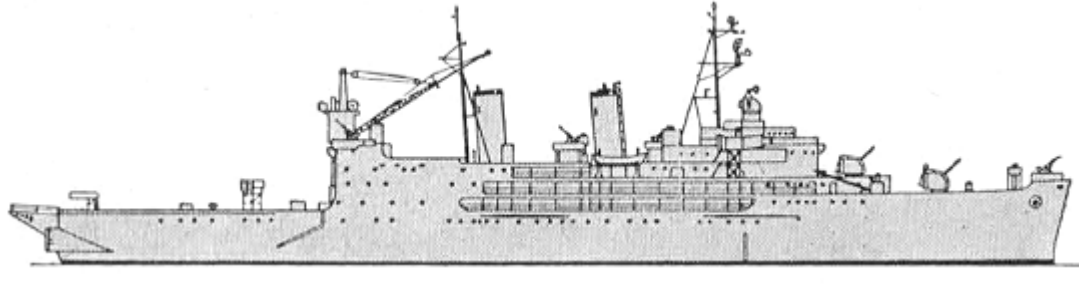
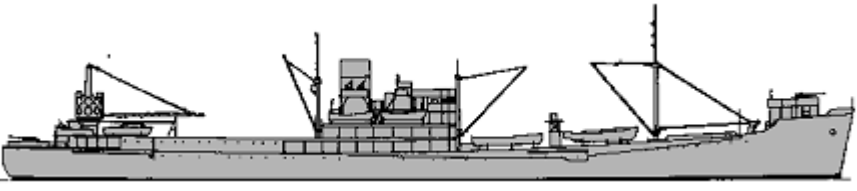
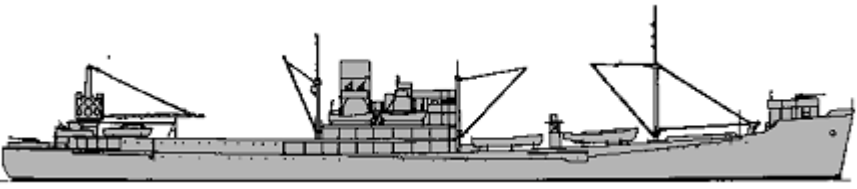
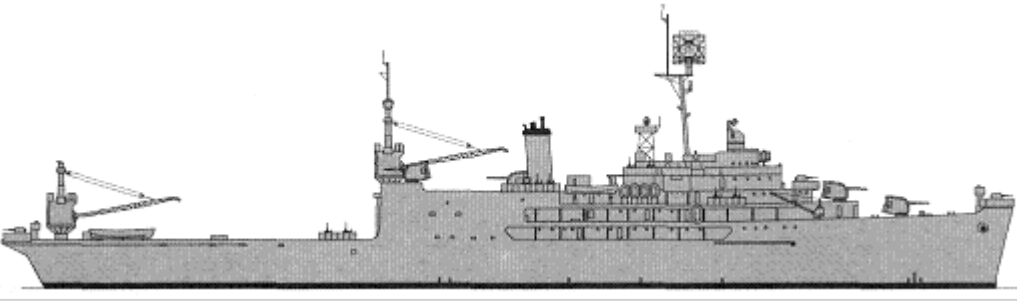
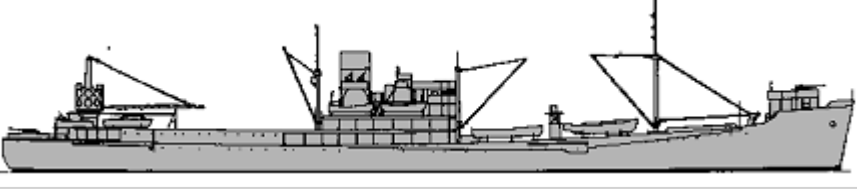
			CVE120	Mindoro	1945		
			CVE121	Rabaul	1946		
			CVE122	Palau	1946		
			CVE123	Tinian	1946		
AV	Curtiss	2	AV4	Curtiss	1940		14900t, 160.7x21.1x6.5m, 4b,2gst, 12000hp, 18kts, 1195p; 4x1-127/38, 4x4-40/60, 12x1-20/70, 30seaplanes (J2F), radars
			AV5	Albermarle	1940		
	Tangier	2	AV8	Tangier	1940		13500t, 150.0x21.2x7.2m, 2b,1gst, 8500hp, 16.5kts, 1075p; 4x1-127/38, 4x1-76/50, 4x2-40/60, 15x1-20/70, 24seaplanes(J2F), radars
			AV9	Pocomoke	1941		
	Chandeleur	1	AV10	Chandeleur	1942		13700t, 150.0x21.2x7.2m, 2b,1gst, 9350hp, 17kts, 1077p; 1x1-127/38, 4x1-76/50 4x2-40/60, 15x1-20/70, 24seaplanes(J2F), radars
	Currituck	4	AV7	Currituck	1944		15092t, 164.7x21.1x6.8m, 4b,2gst, 12000hp, 19.2kts, 1247p; 4x1-127/38, 4x4-40/60, 30seaplanes(J2F), SK radar
			AV11	Norton Sound	1945		
			AV12	Pine Island	1945		
			AV13	Salisbury Island	1945		
	Kenneth Whiting	4	AV14	Kenneth Whiting	1944		12610t, 150.0x21.2x7.2m, 2b,1gst, 8500hp, 16.5kts, 1077p; 2x1-127/38, (2x4+2x2)-40/60, 16x1-20/70, 24seaplanes(J2F), SK radar
			AV15	Hamlin	1944		
			AV16	St. George	1944		
			AV17	Cumberland Sound	1944		
Barnegat	13	AVP10	Barnegat	1941		2620t, 94.7x12.5x3.8m, 4dg,2em, 6080hp, 20kts, 367p; 1x1-127/38, 1x4-40/60(AVP10,48-55), (1x4+2x2)-40/60(AVP37-41), 4x2-20/70(AVP10,48-55), 6x1-20/70(AVP37-41), 2DCT, 2DCR,	
		AVP37	Corson	1944			
		AVP38	Duxbury Bay	1944			
		AVP39	Gardiners Bay	1945			
		AVP40	Floyds Bay	1945			
		AVP41	Greenwich Bay	1945			
		AVP48	Onslow	1943			
AVP49	Orca	1944					

AVP51	San Carlos	1944
AVP52	Shelikof	1944
AVP53	Suisun	1944
AVP54	Timbalier	1946
AVP55	Valcour	1946

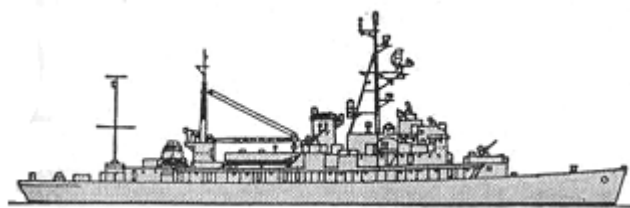

12seaplanes(J2F); SA, SU radars, sonar

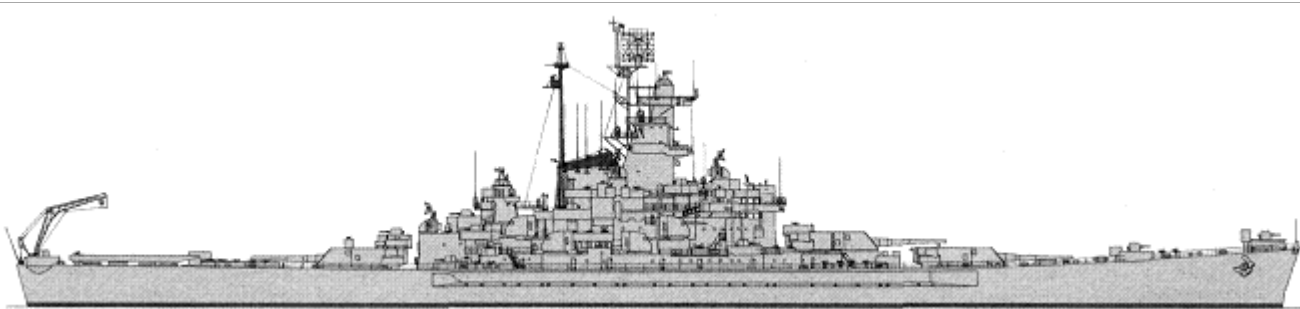
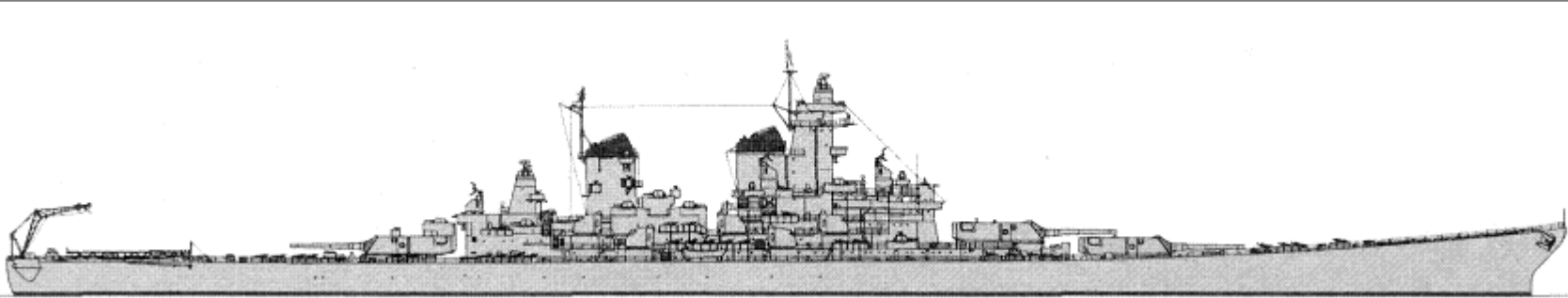
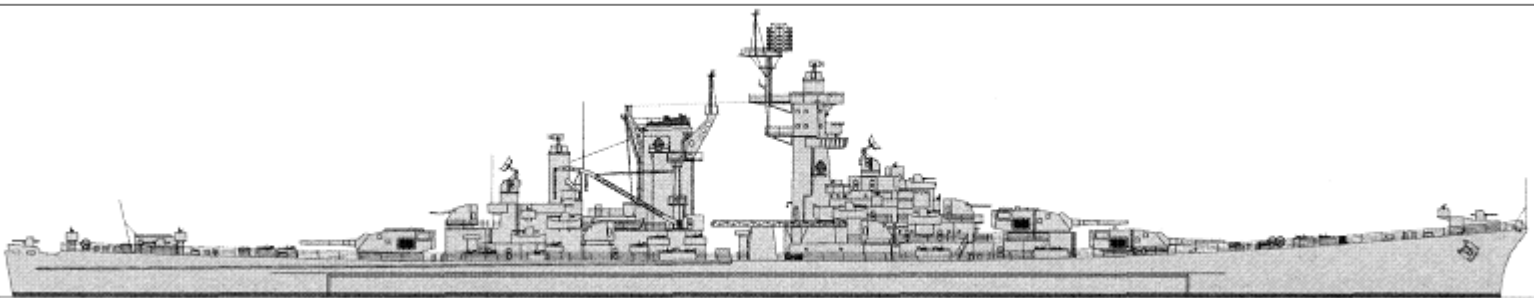
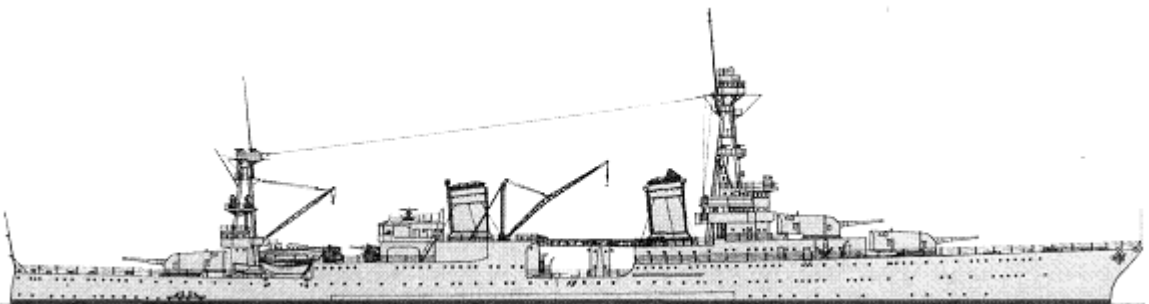
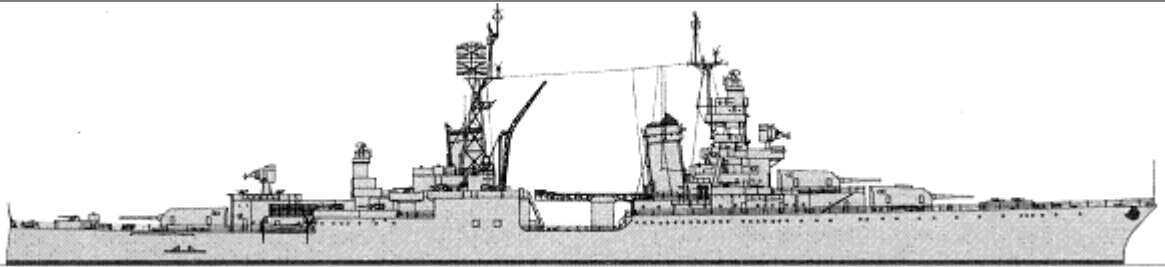

PRINCIPAL SURFACE COMBATANTS

BB	Tennessee	2	BB43	Tennessee	1920		<p>40345t, 190.2x34.8x10.1m, 8b,2stg,4em, 29500hp, 20.5kts, 2375p; 343belt, 203decks, 457turrets, 127CT; 4x3-356/50, 8x2-127/38, 10x4-40/60(BB43), 14x4-40/60(BB44), 43x1-20/70(BB43), 40x2-20/70(BB44); SC-2, SG, Mk8, Mk13, 4x Mk4 radars</p>
			BB44	California	1921		
	Colorado	2	BB45	Colorado	1923		
			BB46	Maryland	1921		
	West Virginia	1	BB48	West Virginia	1923		
Noth Carolina	2	BB55	North Carolina	1941		<p>46700-46796t, 222.1x33.0x10.0m, 8b,4gst, 121000hp, 28kts, 1880p; 305belt, 193deck, 406turrets, 406CT; 3x3-406/45, 10x2-127/38, 24x4-40/60(BB55), 15x4-40/60(BB56), (8x2+20x1)-20/70(BB55), (1x4+8x2+63x1)-20/70(BB56); 2x SG, SK-2(BB55), SK(BB56), SR, SCR-720, Mk3, Mk4, 2x Mk8, 3x Mk12/22, Mk27 radars</p>	
		BB56	Washington	1941			
			BB57	South Dakota	1942		44519t, 207.3x33.0x10.7m, 8b,4gst, 130000hp,

South Dakota	4	BB58	Indiana	1942		27.5kts, 1793p; 310belt, 203decks, 457turrets, 406CT; 3x3-406/45, 8x2-127/38(BB57), 10x2-127/38(BB58-60), 17x4-40/60(BB57), 12x4-40/60(BB58,60), 18x4-40/60(BB59), 77x1-20/70(BB57), (4x2+44x1)-20/70(BB58), (1x4+1x2+31x1)-20/70(BB59), 56x1-20/70(BB60); 2x SG, SK-2, SU, 2x Mk13, 4x Mk12/22, Mk27 radars	
		BB59	Massachusetts	1942			
		BB60	Alabama	1942			
		BB61	Iowa	1943			
Iowa	4	BB62	New Jersey	1943		57540t, 270.4x33.0x11.0m, 8b,4gst, 212000hp, 32.5kts, 1921p; 307belt, 229decks, 495turrets, 440CT; 3x3-406/50, 10x2-127/38, 19x4-40/60(BB61), 20x4-40/60(BB62,64), 14x4-40/60(BB63), (8x2+52x1)-20/70(BB61), (8x2+49x1)-20/70(BB62,64), 3helicopters(HO3S)(BB63); 2x SG, SK(BB61,64), SK-2(BB62,63), SP(BB62), SR(BB61,64), SU(BB61,62), SPS-6(BB63), Mk3(BB61,62), 2x Mk8(BB63), 2x Mk13(BB61,62,64), 4x Mk12/22, Mk27(BB63,64) radars	
		BB63	Missouri	1944			
		BB64	Wisconsin	1944			
		CB1	Alaska	1944			
CB	Alaska	2	CB2	Guam	1944		34253t, 246.4x27.8x9.7m, 4b,4gst, 150000hp, 33kts, 1517p; 229belt, 154decks, 325turrets, 269CT; 3x3-305/50, 6x2-127/38, 14x4-40/60, 34x1-20/70; SK, 2x SG-1, 2x Mk8, 2x Mk12/22 radars
			CA27	Chester	1930		
Northampton	3	CA28	Louisville	1931		14000t, 183.0x20.1x5.9m, 8b,4gst, 107000hp, 32.5kts, 617-748p; 95belt, 51deck, 64turrets, 32CT; 3x3-203/55, 8x1-127/25, (5x4+2x2)-40/60(CA27), (4x4+4x2)-40/60(CA28,31), 13x2-20/70(CA27), 20x1-20/70(CA28,31); SG, SK, SP, Mk3, Mk4 radars	
		CA31	Augusta	1931			
		CA33	Portland	1933			
Portland	1	CA32	New Orleans	1934		15000t, 185.9x20.1x6.4m, 8b,4gst, 107000hp, 32.5kts, 807p; 146belt, 64deck, 64turrets, 32CT; 3x3-203/55, 8x1-127/25, (4x4+4x2)-40/60, 17x1-20/70, SG, SK, Mk8, Mk18 radars	
New Orleans	4	CA36	Minneapolis	1934			
		CA37	Tuscaloosa	1934			
						14000t, 179.2x18.8x6.9m, 8b,4gst, 107000hp, 32.7kts, 868p; 127belt, 57deck, 203turrets, 127CT; 3x3-203/55, 8x1-127/25, 6x4-40/60, 14x2-20/70(CA32), 8x2-20/70(CA36), 28x1-20/70(CA37),	

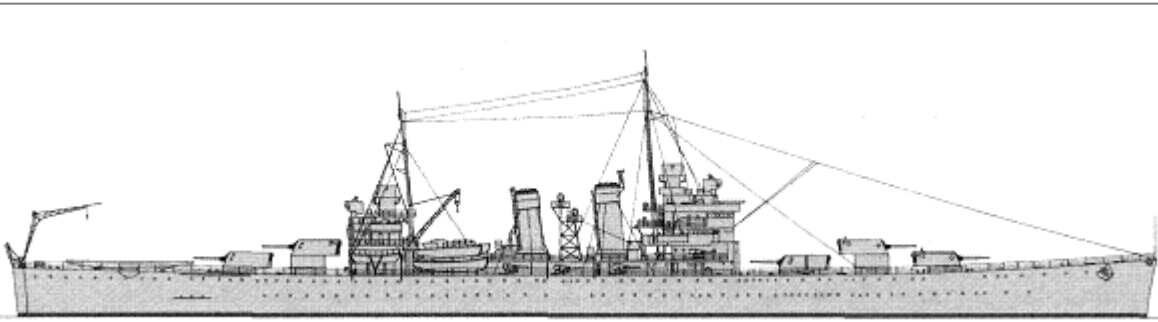
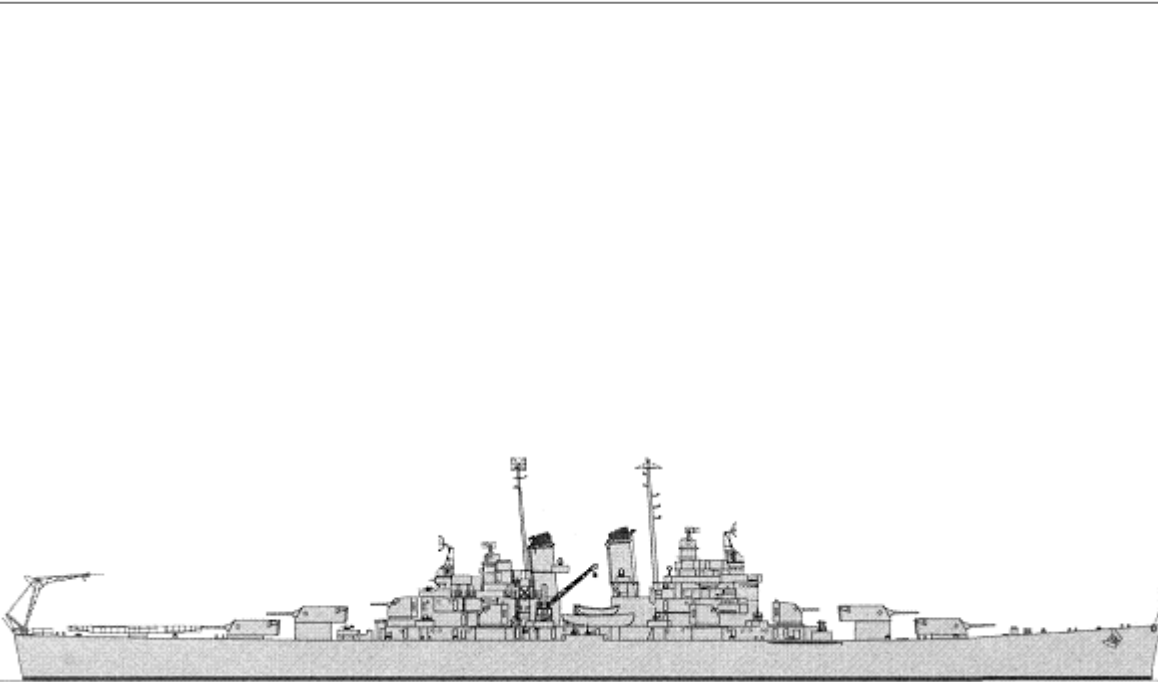
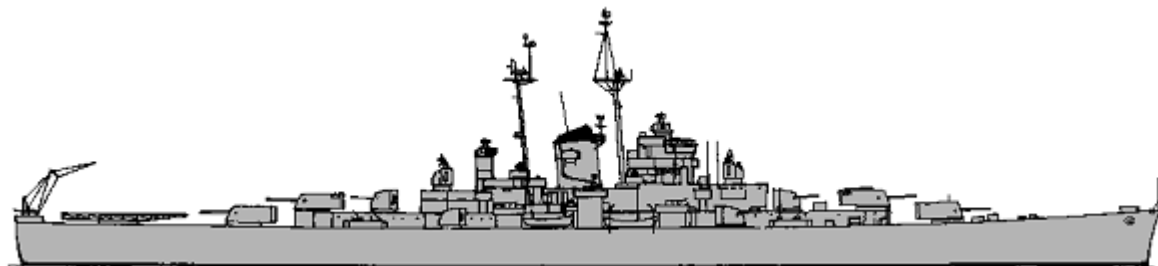
CA										
			CA38	San Francisco	1934	A detailed line drawing of the USS San Francisco (CA-38), a heavy cruiser, shown from a starboard profile view. It features a complex superstructure with multiple masts, funnels, and gun turrets.		26x1-20/70(CA38), 2x SG, SK, SP(CA36), Mk3, Mk4 radars		
	Wichita	1	CA45	Wichita	1939	A detailed line drawing of the USS Wichita (CA-45), a heavy cruiser, shown from a starboard profile view. It has a prominent mainmast and several gun turrets.		14611t, 185.4x18.8x7.2m, 8b,4gst, 100000hp, 33kts, 929p; 152belt, 57deck, 203turrets, 152CT; 3x3-203/55, 8x1-127/38, (4x4+4x2)-40/60, 18x1-20/70; SG, SK-1, 2x Mk25, Mk13 radars		
	Baltimore	14	CA68	Baltimore	1943	A detailed line drawing of the USS Baltimore (CA-68), a heavy cruiser, shown from a starboard profile view. It features a complex superstructure with multiple masts and gun turrets.		17031t, 205.3x21.6x7.3m, 4b,4gst, 120000hp, 33kts, 2039p; 152belt, 64deck, 203turrets, 152CT(CA74-136); 3x3-203/55, 6x2-127/38, 12x4-40/60(CA68-71), (11x4+2x2)-40/60(CA72-136), 24x1-20/70(CA68-71), 22x1-20/70(CA72-75), 14x2-20/70(CA130-136); SG-3, SK-2, SP, Mk13, 2x Mk12/22 radars		
			CA69	Boston	1943					
			CA70	Canberra	1943					
			CA71	Quincy	1943					
			CA72	Pittsburgh	1944					
			CA73	St. Paul	1945					
			CA74	Columbus	1945					
CA75			Helena	1945						
CA130			Bremerton	1945						
CA131			Fall River	1945						
CA132			Macon	1945						
CA133			Toledo	1946						
CA135			Los Angeles	1945						
CA136			Chicago	1945						
Oregon City	3	CA122	Oregon City	1946	A detailed line drawing of the USS Oregon City (CA-122), a heavy cruiser, shown from a starboard profile view. It has a complex superstructure with multiple masts and gun turrets.		17031t, 205.3x21.6x7.3m, 4b,4gst, 120000hp, 33kts, 2039p; 152belt, 64deck, 203turrets, 152CT; 3x3-203/55, 6x2-127/38, (11x4+2x2)-40/60, 10x2-20/70; SG-3, SK-2, SP, Mk13, 2x Mk12/22 radars			
		CA123	Albany	1946						
		CA124	Rochester	1946						
Des Moines	3	CA134	Des Moines	1948	A detailed line drawing of the USS Des Moines (CA-134), a heavy cruiser, shown from a starboard profile view. It features a complex superstructure with multiple masts and gun turrets.		20934t, 218.4x23.0x7.9m, 4b,4gst, 120000hp, 33kts, 1799p; 152belt, 120decks, 203turrets, 165bridge; 3x3-203/55, 6x2-127/38, 12x2-76/50, 12x2-20/70; SG-6, SK-3, SP, SPS-6, 2x Mk13, 4x Mk25, 3x Mk27 radars			
		CA139	Salem	1949						
		CA148	Newport News	1949						

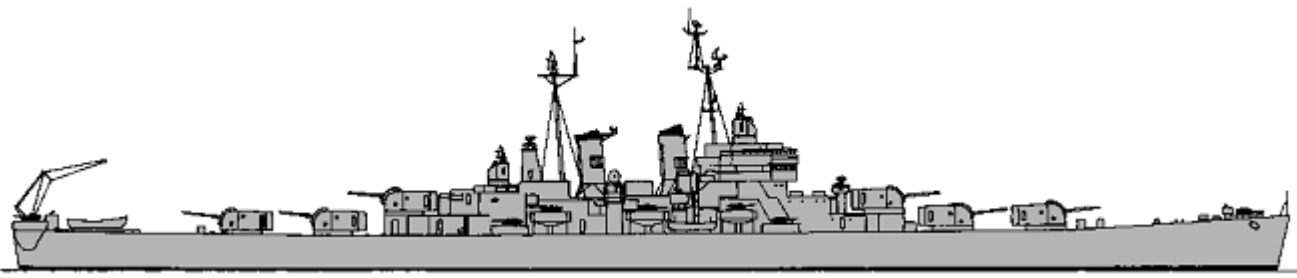
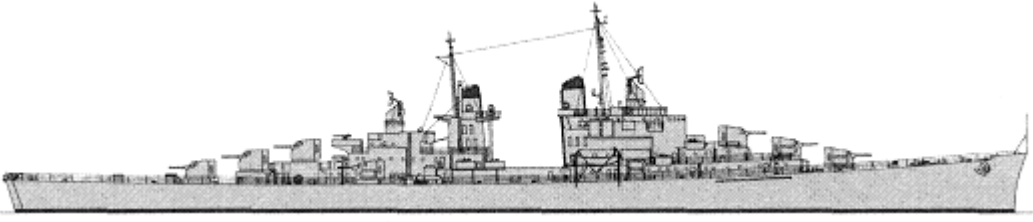
CL	Brooklyn	8	CL40	Brooklyn	1938		12700(CL40-48)-13327(CL49)t, 185.4x21.2(CL40-42,48)-18.8(CL43,46,47,49)x7.3m, 8b,4gst, 100000hp, 32.5kts, 868p; 127belt, 51deck, 165turrets; 5x3-152/47, 4x2-127/38(CL42,49), 8x1-127/25(CL40,41,43,46-48), (4x4+6x2)-40/60, 10x2-20/70(CL40-42,48), 9x2-20/70(CL43), 19x1-20/70(CL46), 18x1-20/70(CL47), 8x1-20/70(CL49); SK(CL40-43,46-48), SK-2(CL49), SG, Mk3(CL40,46), Mk8(CL42,48,49), Mk13(CL41,43,47), 2x Mk4(CL40,41,46,48), 2x Mk12/22(CL42), 2x Mk28 (CL43,47,49) radars
			CL41	Philadelphia	1938		
			CL42	Savannah	1938		
			CL43	Nashville	1938		
			CL46	Phoenix	1939		
			CL47	Boise	1939		
			CL48	Honolulu	1938		
			CL49	St. Louis	1939		
	Cleveland	26	CL55	Cleveland	1942		14144t, 186.0x20.2x7.5m, 4b,4gst, 100000hp, 32.5kts, 1285p; 127belt, 51deck, 165turrets, 127CT(CL55-63); 4x3-152/47, 6x2-127/38, 6x2-40/60(CL55,56), (4x4+4x2)-40/60(CL57,58,60,64-66,80,81), (4x4+6x2)-40/60(CL62,63,67,82,83,86,87,89-92,101-105), 13x1-20/70(CL55,56), 17x1-20/70(CL57,58), 21x1-20/70(CL60,62-66,80,81), 10x1-20/70(CL67,82,83,86,87,89-92,101-105); SC(CL55-58,60,65,66), SG(CL55-58,60,62-67,80-83,86,87,89-92,101-105), SK(CL62,63,89), SK-2(CL64,67,80-83,86,87,90-92,101-105), Mk8 (CL55-58,60,65,66), Mk13(CL62-64,67,80-83,86,87,89-92,101-105), 2x Mk12/22(CL55-58,60,62,63,65,66,89), 2x Mk25(CL64,67,80-83,86,87,90-92,101-105) radars
			CL56	Columbia	1942		
			CL57	Montpelier	1942		
			CL58	Denver	1942		
			CL60	Santa Fe	1942		
			CL62	Birmingham	1943		
			CL63	Mobile	1943		
			CL64	Vincennes	1944		
			CL65	Pasadena	1944		
			CL66	Springfield	1944		
			CL67	Topeka	1944		
			CL80	Biloxi	1943		
			CL81	Houston	1943		
			CL82	Providence	1945		
			CL83	Manchester	1946		
			CL86	Vicksburg	1944		
			CL87	Duluth	1944		
			CL89	Miami	1943		
			CL90	Astoria	1944		
CL91			Oklahoma City	1944			
CL92	Little Rock	1945					
CL101	Amsterdam	1945					
CL102	Portsmouth	1945					
CL103	Wilkes-Barre	1944					
CL104	Atlanta	1944					
CL105	Dayton	1945					
Fargo	2	CL106	Fargo	1945		14464t, 186.0x20.2x7.5m, 4b,4gst, 100000hp, 32.5kts, 1285p; 127belt, 51deck, 165turrets; 4x3-152/47, 6x2-127/38, (6x4+2x2)-40/60, 14x2-20/70; SG, SK-2, Mk13, 2x Mk25 radars	
		CL107	Huntington	1946			

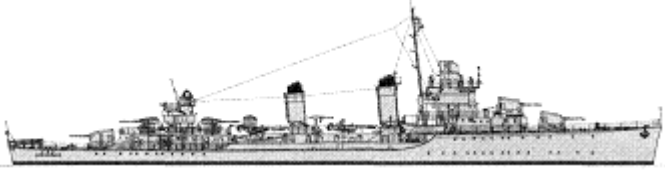
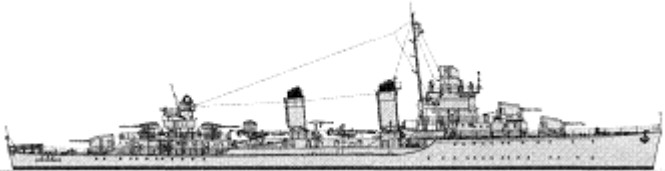
			CL144	Worcester	1948		<p>17997t, 207.1x21.5x7.5m, 4b,4gst, 120000hp, 33kts, 1401p; 127belt, 124deck, 165turrets, 127CT; 6x2-152/47, (11x2+2x1)-76/50, 6x2-20/70; SR-2, SR-6, SPS-8, 2x Mk13, 4x Mk28, 4x Mk35 radars</p>
	Worcester	2	CL145	Roanoke	1949		
CLAA	Atlanta	6	CLAA53	San Diego	1942		<p>8100t, 165.1x16.2x6.2m, 4b,2gst, 75000hp, 32.5kts, 623p; 95belt, 32deck, 32turrets, 63CT(CLAA53,54); 8x2-127/38(CLAA53, 54), 6x2-127/38(CLAA95-98), (1x4+3x2)-40/60(CLAA53), (1x4+5x2)-40/60(CLAA54), (4x4+2x2)-40/60(CLAA95), 8x2-40/60(CLAA96-98), 15x1-20/70(CLAA53,54), 8x2-20/70(CLAA95), 16x1-20/70(CLAA96-98), 2x4-533TT(CLAA53,54,96,97); SC, SG, 2x Mk12/22 radars</p>
			CLAA54	San Juan	1942		
			CLAA95	Oakland	1943		
			CLAA96	Reno	1943		
			CLAA97	Flint	1944		
			CLAA98	Tucson	1945		
	Juneau	3	CLAA119	Juneau	1946		<p>8450t, 165.1x16.2x6.2m, 4b,2gst, 75000hp, 32.5kts, 623p; 95belt, 32deck, 32turrets, 63CT; 6x2-127/38, (6x4+4x2)-40/60, 8x2-20/70; SC, SG, 2x Mk12/22 radars</p>
			CLAA120	Spokane	1946		
			CLAA121	Fresno	1946		
Benson	5	DD421	Benson	1940		<p>2572t, 106.2x11.0x4.0m, 4b,2gst, 50000hp, 35kts, 208p; 4x1-127/38, 2x2-40/60, 4x1-20/70, 2x5-533TT, 6DCT, 2DCR, radars, sonar</p>	
		DD422	Mayo	1940			
		DD425	Madison	1940			
		DD427	Hilary p. Jones	1940			
		DD428	Charles F. Hughes	1940			
Gleaves	14	DD423	Gleaves	1940		<p>2591t, 106.2x11.0x4.0m, 4b,2gst, 50000hp, 35kts, 208p; 4x1-127/38, (2x4+2x2)-40/60(DD423,424,429-432,435,437-440,443), 2x2-40/60(DD441,442), 2x2-20/70(DD423,424,429-432,435,437-440,443), 4x1-20/70(DD441,442), 2x5-533TT(DD441,442), 6DCT, 2DCR, radars, sonar</p>	
		DD424	Niblack	1940			
		DD429	Livermore	1940			
		DD430	Eberle	1940			
		DD431	Plunkett	1940			
		DD432	Kearny	1940			
		DD435	Grayson	1941			
		DD437	Woolsey	1941			
		DD438	Ludlow	1941			
		DD439	Edison	1941			
		DD440	Ericsson	1941			
		DD441	Wilkes	1941			
		DD442	Nicholson	1941			
		DD443	Swanson	1941			

Bristol	11	DD497	Frankford	1943
		DD619	Edwards	1942
		DD623	Nelson	1942
		DD624	Baldwin	1943
		DD626	Satterlee	1943
		DD628	Welles	1943
		DD638	Herndon	1942
		DD641	Tillman	1942
		DD645	Stevenson	1942
		DD646	Stockton	1943
		DD647	Thorn	1943

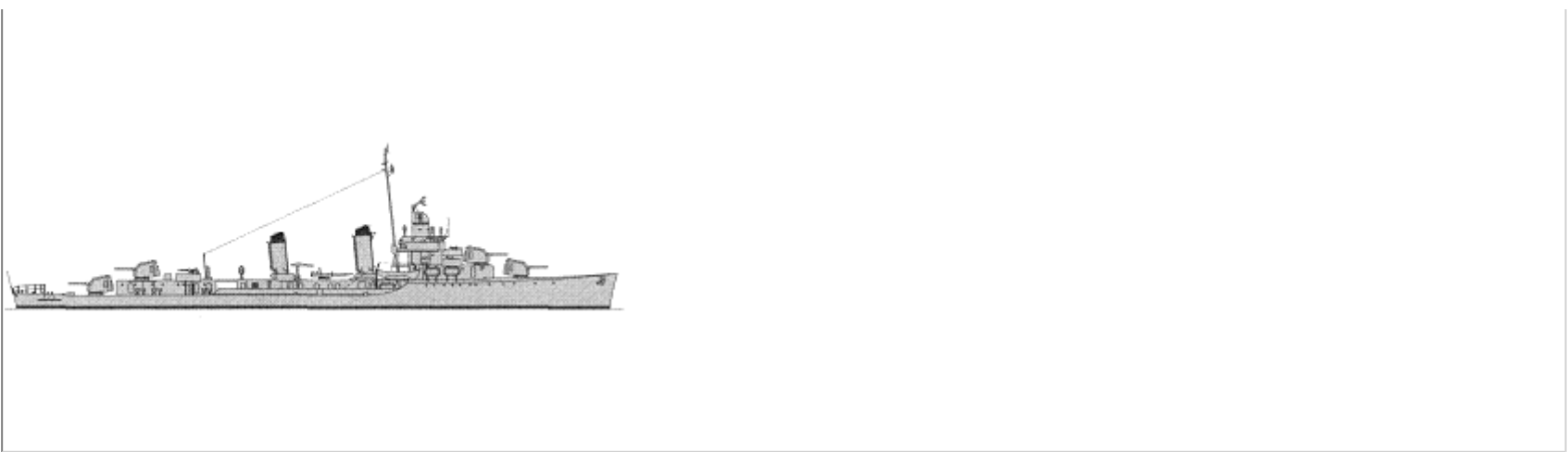

2600t, 106.2x11.0x4.9m, 4b,2gst, 50000hp, 35kts, 208p; 4x1-127/38, (2x4+2x2)-40/60(DD497,623,624,628), 2x2-40/60(DD619,626,638,641,645-647), (2x2+2x1)-20/70(DD497,623,624,628), 7x1-20/70(DD619,626,638,641,645-647), 1x5-533TT(DD619,626,638,641,645-647), 6DCT, 2DCR; radars, sonar

Laffey	22	DD460	Woodworth	1942
		DD491	Farenholt	1942
		DD492	Bailey	1942
		DD598	Bancroft	1942
		DD600	Boyle	1942
		DD601	Champlin	1942
		DD602	Meade	1942
		DD603	Murphy	1942
		DD604	Parker	1942
		DD605	Caldwell	1942
		DD606	Coghlan	1942
		DD607	Frazier	1942
		DD608	Gansevoort	1942
		DD609	Gillespie	1942
		DD610	Hobby	1942
		DD611	Kalk	1942
		DD612	Kendrick	1942
		DD613	Laub	1942
DD614	Mackenzie	1942		
DD615	McLanahan	1942		
DD616	Nields	1943		
DD617	Ordranax	1943		

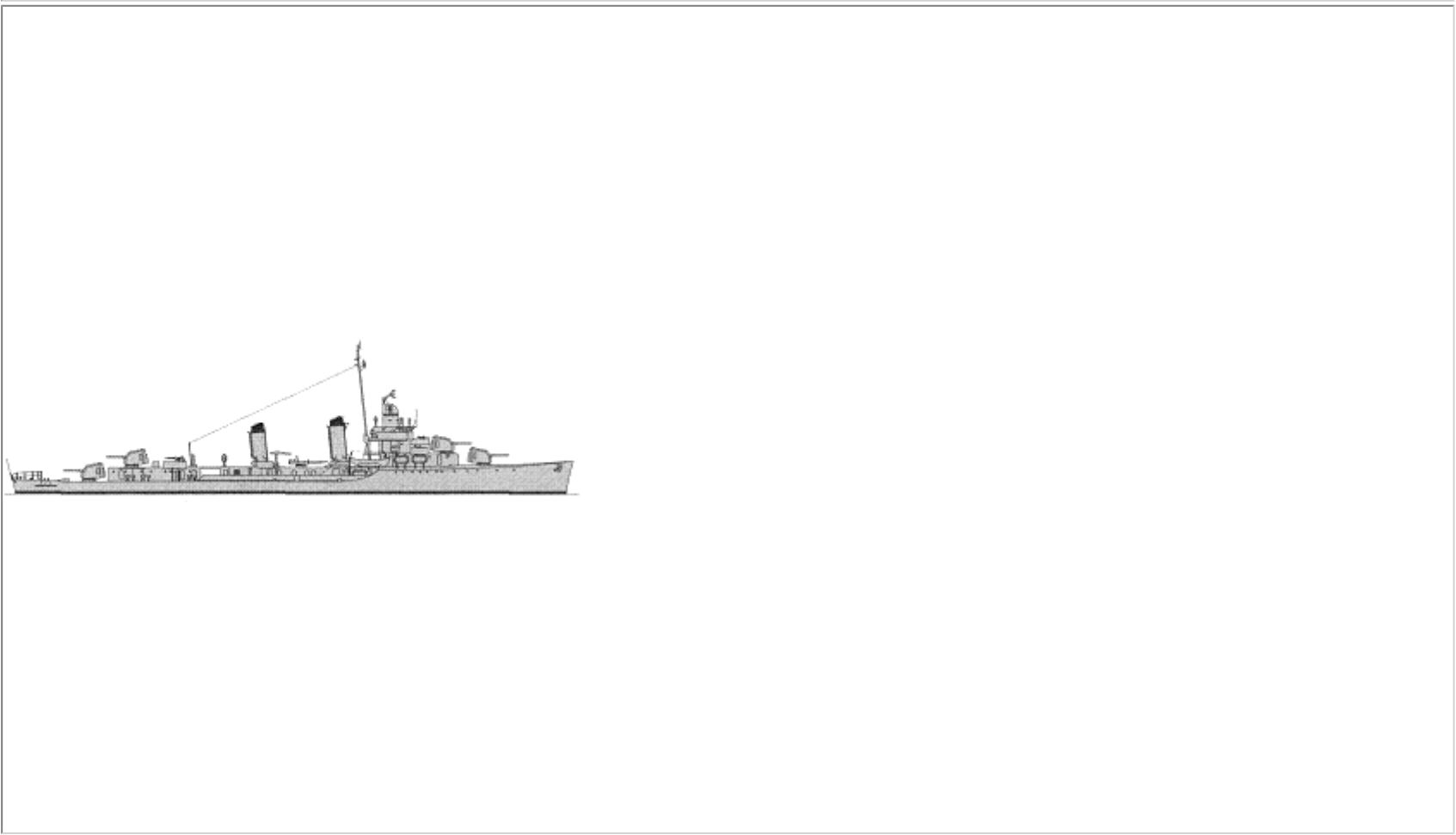

2600t, 106.2x11.0x4.9m, 4b,2gst, 50000hp, 35kts, 208p; 4x1-127/38, 2x2-40/60(DD460,491,492,598,602,605-607,609,611), (2x4+2x2)-40/60(DD600,601,603,604,608,610,612-614,616,617), 4x2-40/60(DD615), 7x1-20/70(DD460,491,492,598,602,605-607,609,611), (2x2+2x1)-20/70(DD600,601,603,604,608,610,612-617), 1x5-533TT(DD460,491,492,598,602,605-607,609,611), 6DCT, 2DCR; radars, sonar

		DD447	Jenkins	1942
		DD448	La Vallette	1942
		DD468	Taylor	1942
		DD470	Bache	1942
		DD471	Beale	1942
		DD472	Guest	1942
		DD473	Bennett	1943
		DD474	Fullam	1943



DD475	Hudson	1943
DD478	Stanly	1942
DD479	Stevens	1943
DD480	Halford	1943
DD500	Ringgold	1942
DD501	Schroeder	1943
DD502	Sigsbee	1943
DD509	Converse	1942
DD510	Eaton	1942
DD511	Foote	1942
DD513	Terry	1943
DD515	Anthony	1943
DD516	Wadsworth	1943
DD517	Walker	1943
DD519	Daly	1943
DD520	Isherwood	1943
DD521	Kimberly	1943
DD527	Ammen	1943
DD528	Mullany	1943
DD530	Trathen	1943
DD531	Hazelwood	1943
DD532	Heermann	1943
DD534	McCord	1943
DD535	Miller	1943
DD536	Owen	1943
DD537	The Sullivans	1943
DD538	Stephen Potter	1943
DD539	Tingey	1943
DD540	Twining	1943
DD541	Yarnall	1943
DD544	Boyd	1943
DD545	Bradford	1943
DD546	Brown	1943
DD547	Cowell	1943
DD550	Capps	1943
DD551	David W. Taylor	1943
DD553	John D. Henley	1943
DD554	Franks	1943
DD556	Hailey	1943

Fletcher

139

DD558	Laws	1943
DD561	Prichett	1944
DD562	Robinson	1944
DD563	Ross	1944
DD564	Rowe	1944
DD565	Smalley	1944
DD566	Stoddard	1944
DD567	Watts	1944
DD568	Wren	1944
DD569	Aulick	1942
DD570	Charles Ausburne	1942
DD571	Claxton	1942
DD572	Dyson	1942
DD573	Harrison	1943
DD574	John Rodgers	1943
DD575	McKee	1943
DD576	Murray	1943
DD578	Wickes	1943
DD580	Young	1943
DD581	Charrette	1943
DD582	Conner	1943
DD583	Hall	1943
DD585	Haraden	1943
DD587	Bell	1943
DD588	Burns	1943
DD589	Izard	1943
DD590	Paul Hamilton	1943
DD592	Howorth	1944
DD593	Killen	1944
DD594	Hart	1944
DD595	Metcalfe	1944
DD596	Shields	1945
DD597	Wiley	1945
DD629	Abbot	1943
DD630	Braine	1943
DD631	Erben	1943
DD642	Hale	1943
DD643	Sigourney	1943
DD644	Stembel	1943
DD649	Albert W.	1943

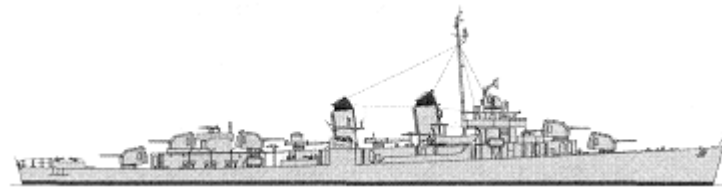

3005t, 114.7x12.1x4.2m, 4b,2gst, 60000hp, 38kts, 273p; 5x1-127/38, (2x4+3x2)-40/60(DD447,448, 473, 478, 520, 521, 528, 530, 531, 534-540, 550, 554, 556, 563, 578, 580, 589, 592, 643, 657, 661, 665, 668, 669, 671-676, 681, 682, 685, 686, 800, 802, 804), 5x2-40/60(DD468, 470, 471, 472, 474, 475, 479, 480, 500, 501, 509-511, 513, 515, 516, 517, 519, 527, 532, 541, 544-547, 551, 553, 558, 561, 562, 564-576, 581-583, 585, 587, 588, 590, 593-597, 629-631, 642, 644, 649-656, 658-660, 662-664, 666, 667, 670, 677-680, 683, 684, 687-691, 793-799), (4x2+3x1)-20/70(DD447,448, 473, 478, 520, 521, 528, 530, 531, 534-540, 550, 554, 556, 563, 578, 580, 589, 592, 643, 657, 661, 665, 668, 669, 671-676, 681, 682, 685, 686, 800, 802, 804), 7x1-20/70(DD468, 470, 471, 472, 474, 475, 479, 480, 500, 501, 509-511, 513, 515, 516, 517, 519, 527, 532, 541, 544-547, 551, 553, 558, 561, 562, 564-576, 581-583, 585, 587, 588, 590, 593-597, 629-631, 642, 644, 649-656, 658-660, 662-664, 666, 667, 670, 677-680, 683, 684, 687-691, 793-799), 1x5-533TT(DD447,448, 473, 478, 520, 521, 528, 530, 531, 534-540, 550, 554, 556, 563, 578, 580, 589, 592, 643, 657, 661, 665, 668, 669, 671-676, 681, 682, 685, 686, 800, 802, 804), 2x5-533TT(DD468, 470, 471, 472, 474, 475, 479, 480, 500, 501, 509-511, 513, 515, 516, 517, 519, 527, 532, 541, 544-547, 551, 553, 558, 561, 562, 564-576, 581-583, 585, 587, 588, 590, 593-597, 629-631, 642, 644, 649-656, 658-660, 662-664, 666, 667, 670, 677-680, 683, 684, 687-691, 793-799), 6DCT, 2DCR; SC, SG, Mk12/22 radars, QGA sonar

	Grant	
DD650	Caperton	1943
DD651	Cogswell	1943
DD652	Ingersoll	1943
DD653	Knapp	1943
DD654	Bearss	1944
DD655	John Hood	1944
DD656	Van Valkenburgh	1944
DD657	Charles J. Badger	1943
DD658	Colahan	1943
DD659	Dashiell	1943
DD660	Bullard	1943
DD661	Kidd	1943
DD662	Bennion	1943
DD663	Heywood L. Edwards	1944
DD664	Richard P. Leary	1944
DD665	Bryant	1943
DD666	Black	1943
DD667	Chauncey	1943
DD668	Clarence K. Bronson	1943
DD669	Cotten	1943
DD670	Dortch	1943
DD671	Gatling	1943
DD672	Healy	1943
DD673	Hickox	1943
DD674	Hunt	1943
DD675	Lewis Hancock	1943
DD676	Marshall	1943
DD677	McDermut	1943
DD678	McGowan	1943
DD679	McNair	1944
DD680	Melvin	1943
DD681	Hopewell	1943
DD682	Porterfield	1943
DD683	Stockham	1944
DD684	Wedderburn	1944

DD

DD685	Picking	1943
DD686	Halsey Powell	1943
DD687	Uhlmann	1943
DD688	Remey	1943
DD689	Wadleigh	1943
DD690	Norman Scott	1943
DD691	Mertz	1943
DD793	Cassin	1943
DD794	Irwin	1944
DD795	Preston	1944
DD796	Benham	1943
DD797	Cushing	1944
DD798	Monssen	1944
DD799	Jarvis	1944
DD800	Porter	1944
DD802	Gregory	1944
DD804	Rooks	1944

DD692	Allen M. Sumner	1944
DD693	Moale	1944
DD694	Ingraham	1944
DD696	English	1944
DD697	Charles S. Sperry	1944
DD698	Ault	1944
DD699	Waldron	1944
DD700	Haynsworth	1944
DD701	John W. Weeks	1944
DD702	Hank	1944
DD703	Wallace L. Lind	1944
DD704	Borie	1944
DD705	Compton	1944
DD706	Gainard	1944
DD707	Soley	1944
DD708	Harlan R. Dickson	1945
DD709	Hugh Purvis	1945
DD722	Barton	1943
DD723	Walke	1944
DD724	Laffey	1944

Allen M.
Sumner

53

DD725	O'Brien	1944
DD727	De Haven	1944
DD728	Mansfield	1944
DD729	Lyman K. Swenson	1944
DD730	Collett	1944
DD731	Maddox	1944
DD732	Hyman	1944
DD734	Purdy	1944
DD744	Blue	1944
DD745	Brush	1944
DD746	Taussig	1944
DD747	Samuel N. Moore	1944
DD748	Harry E. Hubbard	1944
DD752	Alfred A. Cunningham	1944
DD753	John R. Pierce	1944
DD754	Frank E. Evans	1945
DD755	John A. Bole	1945
DD756	Beatty	1945
DD757	Putnam	1944
DD758	Strong	1945
DD759	Lofberg	1945
DD760	John W. Thomason	1945
DD761	Buck	1946
DD762	Henley	1946
DD770	Lowry	1944
DD775	Willard Keith	1944
DD776	James C. Owens	1945
DD777	Zellars	1944
DD778	Massey	1944
DD779	Douglas H. Fox	1944
DD780	Stormes	1945
DD781	Robert K. Huntington	1945
DD857	Bristol	1945
DD710	Gearing	1945

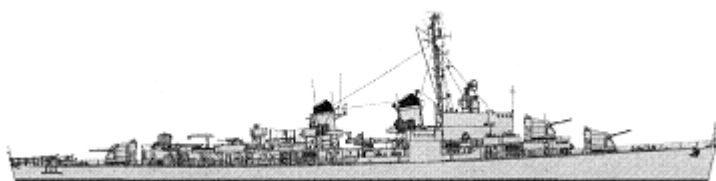

3218t, 114.8x12.5x4.3m, 4b,2gst, 60000hp, 36.5kts, 336p; 3x2-127/38, (3x4+2x2)-40/60, 10x2-20/70, 1x5-533TT, 6DCT, 2DCR; SG, SR, Mk12/22 radars, QGA sonar

DD711	Eugene A. Greene	1945
DD712	Gyatt	1945
DD713	Kenneth D. Bailey	1945
DD714	William R. Rush	1945
DD715	William M. Wood	1945
DD716	Wiltsie	1946
DD717	Theodore E. Chandler	1946
DD718	Hamner	1946
DD763	William C. Lawe	1946
DD764	Lloyd Thomas	1947
DD765	Keppler	1947
DD782	Rowan	1945
DD783	Gurke	1945
DD784	McKean	1945
DD785	Henderson	1945
DD786	Richard B. Anderson	1945
DD787	James E. Kyes	1946
DD788	Hollister	1946
DD789	Eversole	1946
DD790	Shelton	1946
DD808	Dennis J. Buckley	1945
DD817	Corry	1946
DD818	New	1946
DD819	Holder	1946
DD820	Rich	1946
DD821	Johnston	1946
DD822	Robert H. McCard	1946
DD823	Samuel B. Roberts	1946
DD826	Agerholm	1946
DD836	George K. Mackenzie	1945
DD837	Sarsfield	1945
DD838	Ernest G. Small	1945



Gearing

70

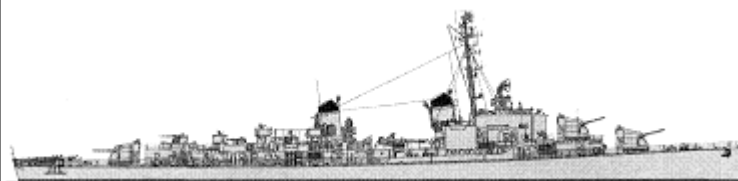
DD839	Power	1945
DD840	Glennon	1945
DD841	Noa	1945
DD842	Fiske	1945
DD843	Warrington	1945
DD844	Perry	1946
DD845	Baussell	1946
DD846	Ozbourn	1946
DD847	Robert L. Wilson	1946
DD848	Witek	1946
DD849	Richard E. Kraus	1946
DD850	Joseph P. Kennedy, Jr.	1945
DD851	Rupertus	1946
DD852	Leonard F. Mason	1946
DD853	Charles H. Roan	1946
DD858	Fred T. Berry	1945
DD859	Norris	1945
DD860	McCaffery	1945
DD861	Harwood	1945
DD862	Vogelgesang	1945
DD863	Steinaker	1945
DD864	Harold J. Ellison	1945
DD865	Charles R. Ware	1945
DD866	Cone	1945
DD867	Stribling	1945
DD868	Brownson	1945
DD869	Arnold J. Isbell	1946
DD870	Fechteler	1946
DD871	Damato	1946
DD872	Forrest Royal	1946
DD884	Floyd B. Parks	1945
DD885	John R. Craig	1945
DD886	Orleck	1945

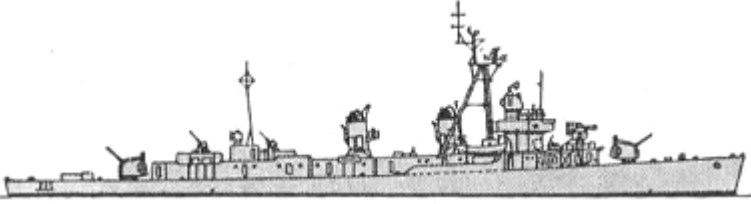
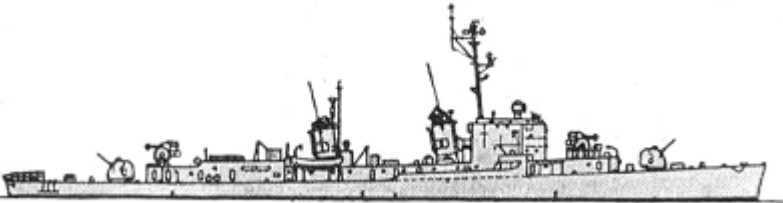

1x5-533TT, 6DCT, 2DCR; SG, SR, Mk12/22 radars,
QGA sonar

			DD887	Brinkley Bass	1945			
			DD888	Stickell	1945			
			DD889	O'Hare	1945			
			DD890	Meredith	1945			
DDE	Fletcher	11	DDE445	Fletcher	1942		2950t, 114.8x12.1x5.5m, 4b,2gst, 60000hp, 35kts; 2x1-127/38, 2x2-76/50, 4x2-20/70, 4-533TT, 1x1-324Weapon Alfa, 2x24-178Hedgehog; SPS-6 radar, QHB sonar	
			DDE446	Radford	1942			
			DDE449	Nicholas	1942			
			DDE450	O'Bannon	1942			
			DDE465	Saufley	1942			
			DDE466	Waller	1942			
			DDE498	Philip	1942			
			DDE499	Renshaw	1942			
			DDE507	Conway	1942			
			DDE508	Cony	1942			
			DDE577	Sproston	1943			
	Gearing		4	DDE719	Epperson	1949		3460t, 119.0x12.5x4.4m, 4b,2gst, 60000hp, 36.8kts, 336p; 2x2-127/38(DDE719,824), 2x2-76/70(DDK825,827), 4x2-20/70, 4-533TT, 1x1-324Weapon Alfa(DDE719,824), 2x1-324Weapon Alfa(DDK825,827), 2x24-178Hedgehog(DDE719,824), 1x24-178Hedgehog(DDK825,827), 1DCR; SPS-6 radar, QHB sonar
				DDE824	Basilone	1949		
				DDK825	Carpenter	1949		
				DDK827	Robert A. Owens	1949		
DDR	Gearing	23	DDR742	Frank Knox	1944		3460t, 119.0x12.5x4.4m, 4b,2gst, 60000hp, 36.8kts, 336p; 3x2-127/38, (3x4+2x2)-40/60, 11x1-20/70, 1x5-533TT, 6DCT, 2DCR; SG, SP, SR, Mk12/22 radars, QGA sonar	
			DDR743	Southerland	1944			
			DDR805	Chevalier	1945			
			DDR806	Higbee	1945			
			DDR807	Benner	1945			
			DDR829	Myles C. Fox	1945			
			DDR830	Everett F. Larson	1945			
			DDR831	Goodrich	1945			
			DDR832	Hanson	1945			
			DDR833	Herbert J. Thomas	1945			
			DDR834	Turner	1945			
			DDR835	Charles P. Cecil	1945			
			DDR873	Hawkins	1945			
			DDR874	Duncan	1945			
			DDR875	Henry W. Tucker	1945			
DDR876	Rogers	1945						
DDR877	Perkins	1945						

DDR878	Vesole	1945
DDR879	Leary	1945
DDR880	Dyess	1945
DDR881	Bordelon	1945
DDR882	Furse	1945
DDR883	Newman K. Perry	

DE59	Foss	1943
DE198	Lovelace	1943
DE199	Manning	1943
DE200	Neundorf	1943
DE201	James E. Craig	1943
DE202	Eichenberger	1943
DE203	Thomason	1943
DE210	Otter	1944
DE214	Scott	1943
DE217	Coolbaugh	1943
DE218	Darby	1943
DE219	J. Douglas Blackwood	1943
DE220	Francis M. Robinson	1944
DE222	Fowler	1944
DE575	Ahrens	1944
DE633	Foreman	1943
DE634	Whitehurst	1943
DE638	Willmarth	1944
DE639	Gendreau	1944
DE640	Fieberling	1944
DE641	William C. Cole	1944
DE642	Paul G. Baker	1944
DE643	Damon M. Cummings	1944
DE644	Vammen	1944
DE665	Jenks	1944
DE666	Durik	1944
DE667	Wiseman	1944
DE678	Harmon	1943
DE679	Greenwood	1943
DE680	Loeser	1943

Buckley

49



1823t, 93.3x11.3x3.4m, 2b,2stg,2em, 12000hp, 23kts, 186p; 2x1-127/38(DE217-219,678-680,696-698,700,701), 3x1-76/50(DE59,198-203,210,214,220-222,575,577,578,633,634,638-644,665-667,681,683,695,699,702-705,790,791,795-800), 1x2-40/60(DE59,198-203,210,214,220-222,633,634,638-644,665-667,681,683,695,699,702-705,790,791,795-800), (1x4+3x2)-40/60(DE217-219,678-680,696-698,700,701), 3x2-40/60(DE575,577,578), 8x1-20/70(DE59,198-203,210,214,220-222,633,634,638-644,665-667,681,683,695,699,702-705,790,791,795-800), 1x3-533TT(DE59,198-203,210,214,220-222,633,634,638-644,665-667,681,683,695,699,702-705,790,791,795-800), 1x24-178Hedgehog, 8DCT, 2DCR; SA, SU radars, sonar

DE681	Gillette	1943
DE683	Henry R. Kenyon	1943
DE696	Spangler	1943
DE697	George	1943
DE699	Marsh	1944
DE700	Currier	1944
DE701	Osmus	1944
DE702	Earl V. Johnson	1944
DE703	Holton	1944
DE704	Cronin	1944
DE705	Frybarger	1944
DE790	Borum	1943
EDE791	Maloy	1943
DE795	Gunason	1944
DE796	Major	1944
DE797	Weeden	1944
DE798	Varian	1944
DE799	Scroggins	1944
DE800	Jack W. Wilke	1944
DE105	Burrows	1943
DE113	Clarence L. Evans	1944
DE162	Levy	1943
DE163	McConnell	1943
DE164	Osterhaus	1943
DE165	Parks	1943
DE166	Baron	1943
DE167	Acree	1943
DE168	Amick	1943
DE169	Atherton	1943
DE170	Booth	1943
DE171	Carroll	1943
DE172	Cooner	1943
DE173	Eldridge	1943
DE176	Micka	1943
DE180	Trumpeter	1943
DE181	Straub	1943
DE182	Gustafson	1943
DE183	Samuel S. Miles	1943

Cannon

53

DE184	Wesson	1943
DE185	Riddle	1943
DE186	Swearer	1943
DE187	Stern	1943
DE188	O'Neill	1943
DE189	Bronstein	1943
DE190	Baker	1943
DE191	Coffman	1943
DE192	Eisner	1944
DE193	Garfield Thomas	1944
DE194	Wingfield	1944
DE195	Thornhill	1944
DE196	Rinehart	1944
DE739	Bangust	1943
DE740	Waterman	1943
DE741	Weaver	1943
DE742	Hilbert	1944
DE743	Lamons	1944
DE744	Kyne	1944
DE745	Snyder	1944
DE746	Hemminger	1944
DE747	Bright	1944
DE748	Tills	1944
DE749	Roberts	1944
DE750	McClelland	1944
DE763	Cates	1943
DE764	Gandy	1944
DE765	Earl K. Olsen	1944
DE766	Slater	1944
DE767	Oswald	1944
DE768	Ebert	1944
DE769	Neal A. Scott	1944
DE770	Muir	1944
DE771	Sutton	1944
DE129	Edsall	1943
DE130	Jacob Jones	1943
DE131	Hammann	1943
DE132	Robert E. Peary	1943
DE133	Pillsbury	1943

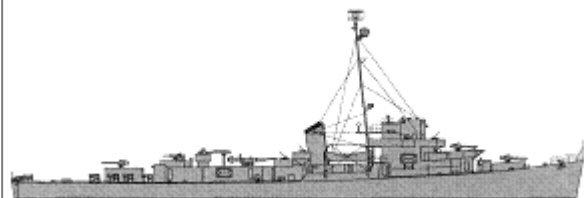

1602t, 93.3x11.2x3.2m, 4dg,2em, 6000hp, 21kts, 186p; 3x1-76/50, 1x2-40/60, 8x1-20/70(DE15,113,162-173,176,180-196739,763,764), 10x1-20/70(DE740-750,765-771), 1x3-533TT, 1x24-178Hedgehog, 8DCT,2DCR, SA, SU radars, sonar

DE134	Pope	1943
DE135	Flaherty	1943
DE137	Herbert C. Jones	1943
DE138	Douglas L. Howard	1943
DE139	Farquhar	1943
DE140	J. R. Y. Blakely	1943
DE141	Hill	1943
DE142	Fessenden	1943
DE144	Frost	1943
DE145	Huse	1943
DE146	Inch	1943
DE147	Blair	1943
DE148	Brough	1943
DE149	Chatelaine	1943
DE150	Neunzer	1943
DE151	Poole	1943
DE152	Peterson	1943
DE238	Stewart	1943
DE239	Sturtevant	1943
DE240	Moore	1943
DE241	Keith	1943
DE242	Tomich	1943
DE243	J. Richard Ward	1943
DE244	Otterstetter	1943
DE245	Sloat	1943
DE246	Snowden	1943
DE247	Stanton	1943
DE248	Swasey	1943
DE249	Marchand	1943
DE250	Hurst	1943
DE251	Camp	1943
DE252	Howard D. Crow	1943
DE253	Pettit	1943
DE254	Picketts	1943
DE255	Sellstrom	1943
DE316	Harveston	1943
DE317	Joyce	1943

Edsall

82

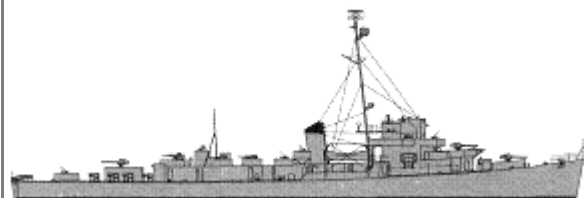

1602t, 93.3x11.2x3.2m, 4d(2), 6000hp, 21kts, 186p; 2x1-127/38(DE251), 3x1-76/50(DE129-135, 137-142, 144-152, 238-250, 252-255, 316-318, 320-338, 382-400), 1x2-40/60(DE129-135, 137-142, 144-152, 238-250, 252-255, 316-318, 320-338, 382-400), (1x4+3x2+2x1)-40/60(DE251), 8x1-20/70(DE129-135, 137-142, 144-152, 238-250, 252-255, 316-318, 320-338, 382-400), 6x1-20/70(DE251), 1x3-533TT(DE129-135, 137-142, 144-152, 238-250, 252-255, 316-318, 320-338, 382-400), 1x24-

FF

DE318	Kirkpatrick	1943
DE320	Menges	1943
DE321	Mosley	1943
DE322	Newell	1943
DE323	Pride	1943
DE324	Falgout	1943
DE325	Lowe	1943
DE326	Thomas J. Gary	1943
DE327	Brister	1943
DE328	Finch	1943
DE329	Kretchmer	1943
DE330	O'Reilly	1943
DE331	Koiner	1943
DE332	Price	1944
DE333	Strickland	1944
DE334	Forster	1944
DE335	Daniel	1944
DE336	Roy O. Hale	1944
DE337	Dale W. Peterson	1944
DE338	Martin H. Ray	1944
DE382	Ramsden	1943
DE383	Mills	1943
DE384	Rhodes	1943
DE385	Richey	1943
DE386	Savage	1943
DE387	Vance	1943
DE388	Lansing	1943
DE389	Durant	1943
DE390	Calcaterra	1943
DE391	Chambers	1943
DE392	Merrill	1943
DE393	Haverfield	1943
DE394	Swenning	1943
DE395	Willis	1943
DE396	Jahnssen	1943
DE397	Wilhoite	1943
DE398	Cockrill	1943
DE399	Stockdale	1943
DE400	Hissem	1944

178Hedgehog, 8DCT, 2DCR; SA, SU radars, sonar

Tacoma	24	PF2	Tacoma	1943
		PF4	Sausalito	1944
		PF5	Hoquiam	1944
		PF7	Albuquerque	1943
		PF8	Everett	1944
		PF21	Bayonne	1945
		PF22	Gloucester	1943
		PF25	Charlottesville	1944
		PF27	Newport	1944
		PF34	Long Beach	1943
		PF36	Glendale	1943
		PF37	San Pedro	1943
		PF38	Coronado	1943
		PF39	Ogden	1943
		PF47	Gallup	1944
		PF48	Rockford	1944
		PF49	Muskogee	1944
		PF50	Carson City	1944
		PF51	Burlington	1944
		PF52	Allentown	1944
		PF53	Machias	1944
		PF54	Sandusky	1944
		PF55	Bath	1944
		PF70	Evansville	1944



2238t, 92.6x11.4x3.9m, 3b,2vte, 5500hp, 20kts, 190p; 3x1-76/50, 2x2-40/60, 9x1-20/70, 1x24-178Hedgehog, 8DCT, 2DCR; SA, SU, Mk26 radars, sonar

Rudderow	20	DE224	Rudderow	1944
		DE225	Day	1944
		DE231	Hodges	1944
		DE579	Riley	1944
		DE580	Leslie L. B. Knox	1944
		DE581	McNulty	1944
		DE582	Metivier	1944
		DE583	George A. Johnson	1944
		DE584	Charles J. Kimmel	1944
		DE585	Daniel A. Joy	1944
		DE586	Lough	1944
		DE587	Thomas F. Nickel	1944
		DE588	Peiffer	1944
		DE589	Tinsman	1944

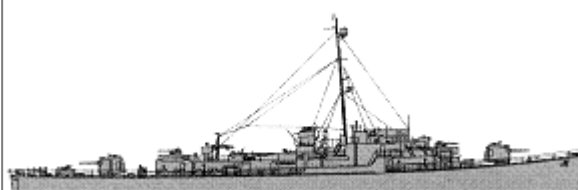

1811t, 93.3x11.3x3.4m, 2b,2stg,2em, 12000hp, 23kts, 156p; 2x1-127/38, 2x2-40/60, 10x1-20/70(DE224,225,231,579-589,706-708), 8x1-20/70(DE684-686), 1x3-533TT, 1x24-178Hedgehog, 8DCT, 2DCR

DE684	DeLong	1943
DE685	Coates	1944
DE686	Eugene E. Elmore	1944
DE706	Holt	1944
DE707	Jobb	1944
DE708	Parle	1944
DE339	John C. Butler	1944
DE340	O'Flaherty	1944
DE341	Raymond	1944
DE342	Richard W. Suesens	1944
DE343	Abercrombie	1944
DE344	Oberrender	1944
DE345	Robert Brazier	1944
DE346	Edwin A. Howard	1944
DE347	Jesse Rutherford	1944
DE348	Key	1944
DE349	Gentry	1944
DE350	Traw	1944
DE351	Maurice J. Manuel	1944
DE352	Naifeh	1944
DE353	Doyle C. Barnes	1944
DE354	Kenneth M. Willett	1944
DE355	Jaccard	1944
DE356	Lloyd E. Acree	1944
DE357	George E. Davis	1944
DE358	Mack	1944
DE359	Woodson	1944
DE360	Johnie Hutchins	1944
DE361	Walton	1944
DE362	Rolf	1944
DE363	Pratt	1944
DE364	Rombach	1944
DE365	McGinty	1944
DE366	Alvin C.	1944

John C.
Butler

78

	Cockrell	
DE367	French	1944
DE368	Cecil J. Doyle	1944
DE369	Thaddeus Parker	1944
DE370	John L. Williamson	1944
DE371	Presley	1944
DE372	Williams	1944
DE402	Richard S. Bull	1944
DE403	Richard M. Rowell	1944
DE405	Dennis	1944
DE406	Edmonds	1944
DE408	Straus	1944
DE409	La Prade	1944
DE410	Jack Miller	1944
DE411	Stafford	1944
DE412	Walter C. Wann	1944
DE414	Le Ray Wilson	1944
DE415	Lawrence C. Taylor	1944
DE416	Melvin R. Nawman	1944
DE417	Oliver Mitchell	1944
DE418	Tabberer	1944
DE419	Robert F. Keller	1944
DE420	Leland E. Thomas	1944
DE421	Chester T. O'Brien	1944
DE422	Douglas A. Munro	1944
DE423	Dufilho	1944
DE424	Haas	1944
DE438	Corbesier	1944
DE439	Conklin	1944
DE440	McCoy Reynolds	1944
DE441	William Seiverling	1944
DE442	Ulvert M.	1944

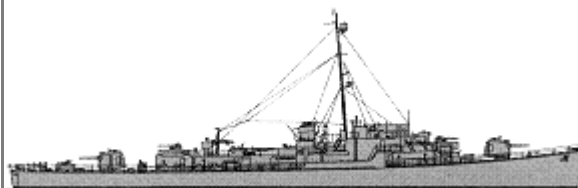

1811t, 93.3x11.3x3.4m, 2b,2stg,2em, 12000hp, 23kts, 156p; 2x1-127/38, 2x2-40/60(DE339-343,345-372,402,403,405,406,408-412,414-424,438-450,508-510,531-536), (1x4+3x2)-40/60(DE537,538), 10x1-20/70(DE339-343,345-372,402,403,405,406,408-412,414-424,438-447,508,509,531-538), (3x2+10x1)-20/70(DE448-450,510), 1x3-533TT(DE339-343,345-372,402,403,405,406,408-412,414-424,438-447,508,509,531-536), 1x24-178Hedgehog, 8DCT, 2DCR; SA, SU radars, sonar

				Moore			
			DE443	Kendall C. Campbell	1944		
			DE444	Goss	1944		
			DE445	Grady	1944		
			DE446	Charles E. Brannon	1944		
			DE447	Albert T. Harris	1944		
			DE448	Cross	1945		
			DE449	Hanna	1945		
			DE450	Joseph E. Connolly	1945		
			DE508	Gilligan	1944		
			DE509	Formoe	1944		
			DE510	Heyliger	1945		
			DE531	Edward H. Allen	1943		
			DE532	Tweedy	1944		
			DE533	Howard F. Clark	1944		
			DE534	Silverstein	1944		
			DE535	Lewis	1944		
			DE536	Bivin	1944		
			DE537	Rizzi	1945		
			DE538	Osberg	1945		
FFC	Buckley	1	DEC698	Raby	1943	A detailed line drawing of the USS Raby (DEC-698), a coastal combatant. It features a complex superstructure with multiple masts, radar domes, and gun mounts. The hull number '698' is visible on the bow.	1823t, 93.3x11.3x3.4m, 2b,2stg,2em, 12000hp, 23kts, 186p; 2x1-127/38, (1x4+3x2)-40/60, 6x1-20/70, 2x24-278Hedgehog, 8DCT, 2DCR; SA, SU, SPS-6 radars, sonar
FFR	Buckley	7	DER51	Buckley	1943	A detailed line drawing of the USS Buckley (DER-51), a coastal combatant. It shows a similar design to the Raby but with a slightly different superstructure. The hull number '51' is visible on the bow.	1823t, 93.3x11.3x3.4m, 2b,2stg,2em, 12000hp, 23kts, 186p; 2x1-127/38, (1x4+3x2)-40/60, 6x1-20/70, 1x24-178Hedgehog, 8DCT, 2DCR; SA, SU, SPS-6 radars, sonar
			DER57	Fogg	1943		
			DER153	Reuben James	1943		
			DER213	William T. Powell	1944		
			DER223	Spangenberg	1944		
			DER577	Alexander J. Luke	1944		
			DER578	Robert I. Paine	1944		

PATROL AND COASTAL COMBATANTS

PC461	1942
PC465	1942
PC466	1942
PC470	1942
PC483	1942
PC484	1942
PC485	1942
PC486	1942
PC487	1942
PC495	1942
PC553	1942
PC560	1942
PC564	1942
PC565	1942
PC566	1942
PC567	1942
PC568	1942
PC569	1942
PC570	1942
PC571	1942
PC572	1942
PC579	1942
PC580	1942
PC581	1942
PC586	1942
PC592	1942
PC597	1943
PC600	1942
PC601	1942
PC602	1942
PC603	1942
PC606	1943
PC610	1942
PC616	1942
PC617	1942
EPC618	1942
PC619	1942
PC620	1943
PC776	1943
PC777	1943

PC461

124



PC778	1943
PC779	1943
PC780	1943
PC781	1943
PC782	1943
PC785	1943
PC786	1943
PC787	1943
PC790	1944
PC797	1944
PC799	1944
PC808	1945
PC817	1943
PC819	1943
PC820	1943
PC822	1944
PC1077	1942
PC1078	1943
PC1079	1943
PC1081	1943
PC1086	1944
PC1087	1944
PC1119	1942
PC1120	1943
PC1125	1943
PC1130	1943
PC1135	1943
PC1138	1943
PC1140	1944
PC1141	1943
PC1142	1944
PC1143	1944
PC1144	1944
PC1145	1944
PC1146	1944
PC1149	1944
PC1167	1943
PC1168	1943
PC1170	1944
PC1171	1943
PC1172	1943



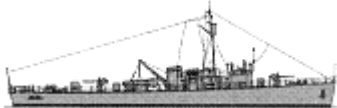

463t, 52.9x7.1x3.3m, 2d, 2880hp, 19kts, 65p; 1x1-76/50, 1x1-40/60, 4x1-20/70, 2x4-178Mousetrap, 2DCT, 2DCR; SU radar, sonar

PC

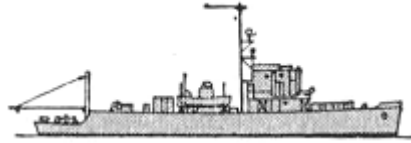
PC1173	1943
PC1174	1943
PC1175	1943
PC1176	1943
PC1179	1944
PC1180	1944
PC1181	1943
PC1182	1943
PC1185	1944
PC1186	1944
PC1191	1942
PC1193	1943
PC1196	1943
PC1198	1943
PC1201	1943
PC1208	1943
PC1209	1944
PC1210	1944
PC1211	1943
PC1212	1943
PC1213	1943
PC1216	1943
PC1225	1943
PC1228	1943
PC1229	1943
PC1230	1943
PC1231	1943
PC1232	1943
PC1233	1943
PC1237	1943
PC1240	1943
PC1242	1943
PC1246	1943
PC1252	1943
PC1253	1943
PC1254	1943
PC1260	1943
PC1262	1943
PC1263	1943
PC1546	1944

		PC1547	1944		
		PC1569	1945		
		PC1590	1942		
PC(C)461	12	PC(C)463	1942		463t, 52.9x7.1x3.3m, 2d, 2880hp, 19kts, 65p; 1x1-76/50, 2x4-178Mousetrap, 2DCT, 2DCR; SU radar, sonar
		PC(C)582	1942		
		PC(C)588	1942		
		PC(C)589	1942		
		PC(C)802	1945		
		PC(C)1136	1943		
		PC(C)1137	1943		
		PC(C)1169	1944		
		PC(C)1177	1943		
		PC(C)1178	1944		
		PC(C)1244	1943		
		PC(C)1251	1943		
PGM10	2	PGM10	1944		463t, 52.9x7.1x3.3m, 2d, 2880hp, 19kts, 65p; 2x2-40/60, 6x1-20/70, 1x2-60/12mortar, 2x1-12.7/90, 2DCT, 2DCR; SU radar, sonar
		PGM31	1945		
PCE842	15	PCE842	1944		903t, 56.2x10.1x2.9m, 2d, 2000hp, 15.1kts, 96p; 1x1-76/50, 2x2-40/60, 5x1-20/70, 1x24-178Hedgehog, 4DCT, 2DCR; SU radar, sonar
		PCE843	1944		
		PCE845	1944		
		PCE846	1944		
		PCE870	1943		
		PCE874	1943		
		PCE880	1944		
		PCE892	1944		
		PCE894	1944		
		PCE895	1944		
		PCE899	1945		
		PCE900	1945		
		PCE902	1945		
		PCE903	1945		
		PCE904	1945		
PCE(R)	8	PCE(R)849	1944		903t, 56.2x10.1x2.9m, 2d, 2000hp, 15.1kts, 96p; 1x1-76/50, 1x2-40/60, 4x1-20/70, 1x24-178Hedgehog, 4DCT, 2DCR; SU radar, sonar
		PCE(R)850	1944		
		PCE(R)851	1944		
		PCE(R)852	1944		
		PCE(R)853	1944		
		EPCE(R)855	1944		
		PCE(R)856	1944		
		EPCE(R)857	1945		

PCE(C)	6	PCE(C)873	1943		903t, 56.2x10.1x2.9m, 2d, 2000hp, 15.1kts, 96p; 1x1-76/50, 1x2-40/60, 4x1-20/70, 1x24-178Hedgehog, 4DCT, 2DCR; SU radar, sonar	
		PCE(C)877	1944			
		PCE(C)882	1945			
		PCE(C)886	1945			
		PCE(C)896	1944			
		PCE(C)898	1945			
PCS	19	PCS1376	1943		278t, 41.5x7.5x2.4m, 2d, 800hp, 14kts, 57p; 1x1-76/50, 1x1-40/60, 2x1-20/70, 2x4-178Mousetrap, 4DCT, 2DCR; SU radar, sonar	
		PCS1378	1944			
		PCS1380	1944			
		PCS1383	1944			
		PCS1384	1944			
		PCS1385	1944			
		PCS1386	1944			
		PCS1387	1944			
		PCS1392	1944			
		PCS1401	1945			
		PCS1413	1943			
		PCS1414	1943			
		PCS1423	1943			
		PCS1426	1944			
		PCS1431	1944			
		PCS1444	1944			
		PCS1445	1944			
		PCS1446	1944			
		PCS1448	1944			
SC	SC497	3	SC665	1942		136t, 33.8x5.5x2.0m, 2d, 2400hp, 21kts, 27p; 1x1-40/60, 3x1-20/70, 2x4-178Mousetrap, 2DCT, 2DCR; SU radar, QC sonar
			SC679	1942		
			SC716	1943		
YP	YP78	8	YP584-591	1943	No picture	51t, 22.9x4.9m, 2d, 400hp

MINE WARFARE AND MINE COUNTERMEASURES

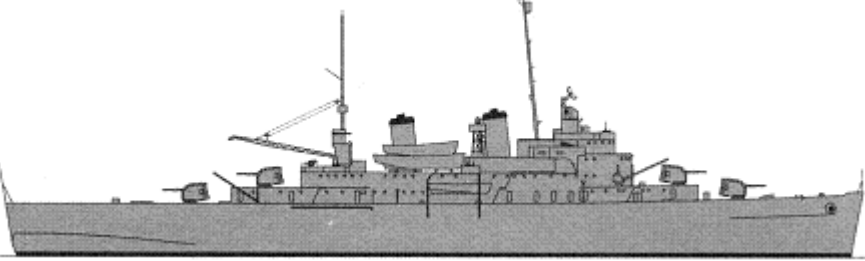
CM	Terror	1	CM5	Terror	1942		8640t, 138.6x18.3x6.0m, 4b,2gst, 11000hp, 18kts, 481p; 4x1-127/38, 4x4-40/60, 14x1-20/70, 900mines; SC, SG, Mk4 radars
			DM23	Robert H. Smith	1944		
				Thomas E.			

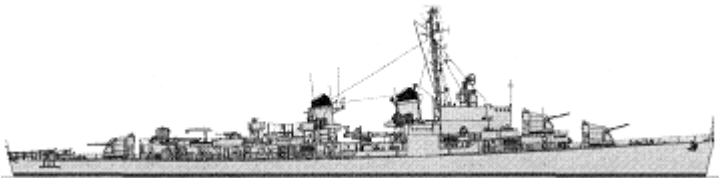
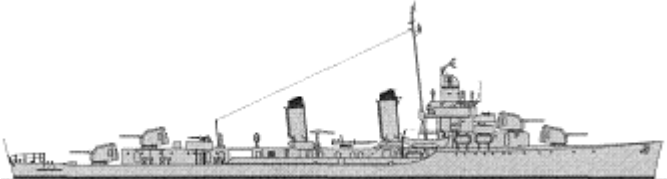
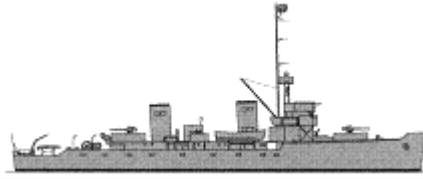
DM	Robert H. Smith	10	DM24	Fraser	1944		<p>3218t, 114.8x12.5x4.3m, 4b,2gst, 60000hp, 36.5kts, 336p; 3x2-127/38, (2x4+2x2)-40/60, 8x1-20/70, 4DCT, 2DCR, 120mines; SG, SR, Mk12/22 radars, QGA sonar</p>
			DM25	Shannon	1944		
			DM26	Harry F. Bauer	1944		
			DM27	Adams	1944		
			DM28	Tolman	1944		
			DM29	Henry A. Wiley	1944		
			DM30	Shea	1944		
			DM32	Lindsey	1944		
			DM33	Gwin	1944		
DMS	Bristol	20	DMS19	Ellyson	1941		<p>2600t, 106.2x11.0(DMS19-40)-11.3(DMS41,42)x4.9m, 4b,2gst, 50000hp, 35kts, 208p; 3x1-127/38, 2x2-40/60(DMS19-21,23,25-27,30), (2x4+2x2)-40/60(DMS31-42), 7x1-20/70(DMS19-21,23,25-27,30), (2x2+2x1)-20/70(DMS31-42), 2DCT, 2DCR, sweeping gear; radars, sonar</p>
			DMS20	Hambleton	1941		
			DMS21	Rodman	1942		
			DMS23	Macomb	1942		
			DMS25	Fitch	1942		
			DMS26	Hobson	1942		
			DMS27	Jeffers	1942		
			DMS30	Gherardi	1942		
			DMS31	Mervine	1942		
			DMS32	Quick	1942		
			DMS33	Carmick	1942		
			DMS34	Doyle	1943		
			DMS35	Endicott	1943		
			DMS36	McCook	1943		
DMS37	Davison	1942					
DMS38	Thompson	1943					
DMS39	Cowie	1942					
DMS40	Knight	1942					
DMS41	Doran	1942					
DMS42	Earle	1942					
	Raven	1	AM55	Raven	1940		<p>1040t, 67.1x9.8x2.8m, 2d, 2880hp, 18kts, 105p; 1x1-76/50, 2x1-40/60, 8x1-20/70, 1x24-178Hedgehog, 4DCT, 2DCR, 80mines, sweeps</p>
			AM57	Auk	1942		
			AM58	Broadbill	1942		
			AM59	Chickadee	1942		
			AM60	Nuthatch	1942		
			AM61	Pheasant	1942		

Auk

63

AM62	Sheldrake	1942
AM64	Starling	1942
AM100	Heed	1943
AM101	Herald	1943
AM102	Motive	1943
AM103	Oracle	1943
AM104	Pilot	1943
AM105	Pioneer	1943
AM107	Prevail	1943
AM108	Pursuit	1943
AM109	Requisite	1943
AM110	Revenge	1943
AM111	Sage	1943
AM112	Seer	1942
AM114	Staff	1942
AM116	Speed	1942
AM117	Strive	1942
AM118	Steady	1942
AM119	Sustain	1942
AM120	Sway	1943
AM122	Swift	1943
AM123	Symbol	1942
AM124	Threat	1943
AM126	Token	1942
AM127	Tumult	1943
AM128	Velocity	1943
AM131	Zeal	1943
AM314	Champion	1943
AM315	Chief	1943
AM316	Competent	1943
AM317	Defense	1944
AM318	Devastator	1944
AM319	Gladiator	1944
AM320	Impeccable	1944
AM322	Spear	1943
AM323	Triumph	1944
AM324	Vigilance	1944
AM340	Ardent	1944
AM341	Dextrous	1943
AM372	Murrelet	1945
AM373	Peregrine	1945

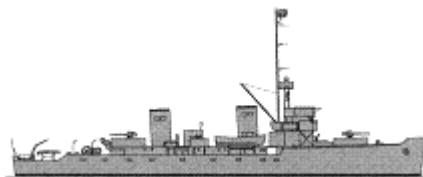

1250t, 67.4x9.8x3.3m, 2d, 2880hp, 18kts, 105p; 1x1-76/50, 2x1-40/60, 8x1-20/70, 1x24-178Hedgehog, 4DCT, 2DCR, 80mines, sweeps

MSO

AM374	Pigeon	1945
AM375	Pochard	1944
AM376	Ptarmigan	1945
AM377	Quail	1945
AM378	Redstart	1945
AM379	Roselle	1945
AM380	Ruddy	1945
AM381	Scoter	1945
AM382	Shoveller	1945
AM383	Surfbird	1944
AM384	Sprig	1945
AM385	Tanager	1945
AM386	Tercel	1945
AM387	Toucan	1944
AM388	Towhee	1945
AM389	Waxwing	1945
AM390	Wheatear	1945
AM159	Change	1944
AM160	Clamour	1944
AM161	Climax	1944
AM162	Compel	1944
AM163	Concise	1944
AM164	Control	1944
AM165	Counsel	1944
AM214	Crag	1944
AM215	Cruise	1944
AM218	Density	1944
AM219	Design	1944
AM220	Device	1944
AM221	Diploma	1944
AM223	Dour	1944
AM224	Eager	
AM232	Execute	1944
AM233	Facility	1944
AM238	Garland	1944
AM239	Gayety	1944
AM240	Hazard	1944
AM241	Hilarity	1944
AM242	Inaugural	1944
AM249	Incredible	1944

Admirable 59

AM252	Instill	1944
AM253	Intrigue	1944
AM254	Invade	1944
AM255	Jubilant	1943
AM256	Knave	1943
AM261	Mainstay	1944
AM269	Opponent	1944
AM275	Pirate	1944
AM277	Pledge	1944
AM280	Prowess	1944
AM283	Ransom	1944
AM284	Rebel	1944
AM285	Recruit	1944
AM288	Reign	1946
AM289	Report	1946
AM296	Scout	1944
AM297	Scrimmage	1944
AM298	Scuffle	1944
AM299	Sentry	1944
AM300	Serene	1944
AM301	Shelter	1944
AM302	Signet	1944
AM303	Skirmish	1944
AM304	Scurry	1944
AM306	Specter	1944
AM307	Staunch	1944
AM308	Strategy	1944
AM309	Strength	1944
AM310	Success	1944
AM311	Superior	1944
AM356	Creddock	1945
AM357	Dipper	1945
AM362	Gadwall	1945
AM364	Graylag	1945
AM365	Harlequin	1945
AM366	Harrier	1945
AMS1	Albatross	1942
AMS2	Bobolink	1943
AMS3	Bunting	1943
AMS4	Cardinal	1943
AMS5	Condor	1943

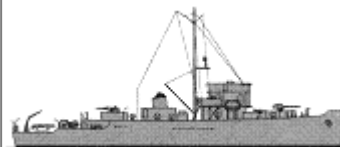

945t, 56.2x10.1x3.0m, 2d, 2000hp, 15.1kts, 96p; 1x1-76/50, 2x1-40/60, 4x1-20/70, sweeps; SU radar, sonar

MSC YMS 58

AMS6	Courser	1943
AMS7	Crow	1943
AMS8	Curlew	1943
AMS9	Flicker	1943
AMS10	Firecrest	1943
AMS11	Flamingo	1942
AMS12	Goldfinch	1944
AMS13	Grackle	1943
AMS14	Grosbeak	1943
AMS15	Grouse	1943
AMS16	Gull	1944
AMS17	Hawk	1943
AMS18	Heron	1943
AMS19	Hornbill	1944
AMS20	Hummer	1944
AMS21	Jackdaw	1944
AMS22	Kite	1944
AMS23	Lark	1943
AMS24	Linnet	1943
AMS25	Magpie	1943
AMS26	Merganser	1944
AMS27	Mockingbird	1944
AMS28	Osprey	1944
AMS29	Ostrich	1944
AMS31	Partridge	1945
AMS32	Pelican	1945
AMS33	Plover	1944
AMS34	Redhead	1944
AMS35	Sanderling	1944
AMS36	Swallow	1944
AMS37	Swan	1944
AMS38	Verdin	1944
AMS39	Waxbill	1944
AMS40	Chatterer	1944
AMS41	Barbet	1942
AMS42	Brambling	1942
AMS43	Brant	1942
AMS44	Courlan	1942
AMS45	Crossbill	1942
AMS46	Egret	1943



278t, 41.5x7.5x2.4m, 2d, 800hp, 14kts, 57p; 1x1-76/50, 1x1-40/60, 2x1-20/70, 2x4-178Mousetrap, 4DCT, 2DCR; SU radar, sonar

			AMS47	Fulmar	1943		
			AMS48	Lapwing	1943		
			AMS49	Lorikeet	1943		
			AMS50	Nightingale	1943		
			AMS51	Reedbird	1943		
			AMS52	Rhea	1943		
			AMS53	Robin	1943		
			AMS54	Ruff	1943		
			AMS55	Seagull	1943		
			AMS56	Turkey	1944		
			AMS57	Redpoll	1943		
			AMS58	Siskin	1944		
			AMS59		1945		
MHC	Minah	1	AMc204	Minah	1944		278t, 41.5x7.5x2.4m, 2d, 800hp, 14kts, 57p; 1x1-76/50, 1x1-20/70, diving equipment; SU radar, sonar
	LCT(6)	6	AMCU1		1944		320t, 36.3x10.0x1.2m, 3d, 675hp, 8kts, 13p; 2x1-20/70, diving equipment; SO radar, sonar
			AMCU2		1944		
			AMCU3		1944		
AMCU4				1944			
AMCU5				1944			
AMCU6				1944			
LCI(L)	1	AMCU11		1943		385t, 48.9x7.2x1.6m, 8d(2), 2320hp, 15.5kts, 29p; 5x1-20/70, diving equipment; SO radar, sonar	
MSB	MSB1	4	MSB1-4		1945	No picture	42t, 17.5x4.8x1.3m, 2d, 300hp, 12kts, 6p; sweeps
	MSL1	4	MSL1-4		1946	No picture	10t, 11.0x3.5x1.1m, 1gt, 200hp, 10kts, 4p; sweep
	MSL5	25	MSL5-29		1948	No picture	10t, 11.0x3.5x1.1m, 1gt, 200hp, 10kts, 4p; sweep
	MSL30	1	MSL30		1948	No picture	10t, 11.0x3.5x1.1m, 1gt, 200hp, 10kts, 4p; sweep

COMMAND SHIPS

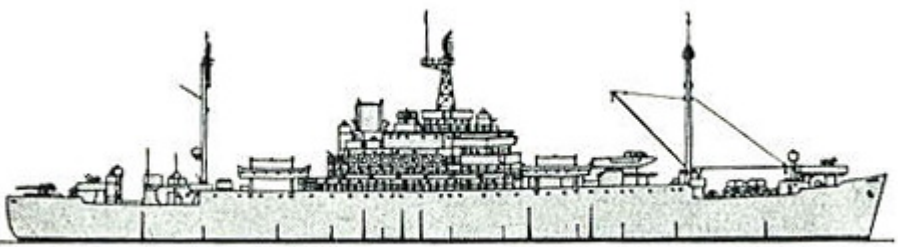
Appalachian	4	AGC1	Appalachian	1943		13910t, 140.0x19.2x7.3m, 2b,1gst, 6600hp, 17kts, 875p; 2x1-127/38, 4x2-40/60, 14x1-20/70; 2LCVP, 4LCPL, 2LCPR, 2LCC, 165HQ persons; SR, SU, SK, SP radars
		AGC2	Blue Ridge	1943		
		AGC3	Rocky Mount	1943		
		AGC5	Catoctin	1944		
		AGC7	Mount McKinley	1944		

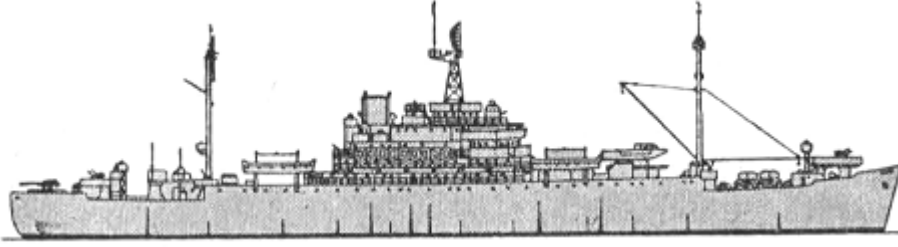
AGC	Mount McKinley	11	AGC8	Mount Olympus	1944		12560t, 139.9x19.2x7.6m, 2b,1gst, 6600hp, 17kts, 1063p; 2x1-127/38, 4x2-40/60, 14x1-20/70(AGC7-14), 12x1-20/70(AGC15-17); 2LCVP(AGC7-14), 4LCPL, 2LCC(AGC7-14), 1LCPR(AGC15-17), 336(AGC7-14)-317(AGC15-17)persons of HQ; SR, SU, SK, SP radars
			AGC9	Wasatch	1944		
			AGC10	Auburn	1944		
			AGC11	Eldorado	1944		
			AGC12	Estes	1944		
			AGC13	Panamint	1944		
			AGC14	Teton	1944		
			AGC15	Adirondack	1945		
			AGC16	Pocono	1945		
			AGC17	Taconic	1946		
	Williamsburg	1	AGC369	Williamsburg	1930	No picture	1820t, 68.3x11.0x4.9m, 2d, 2200hp, 16kts; 2x1-76/50

AMPHIBIOUS

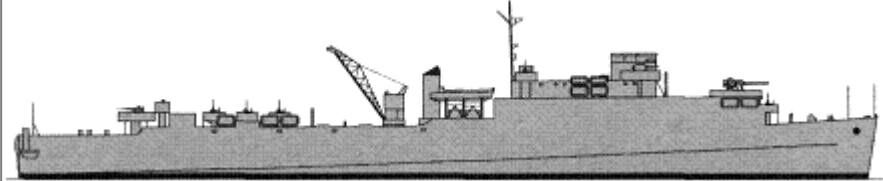
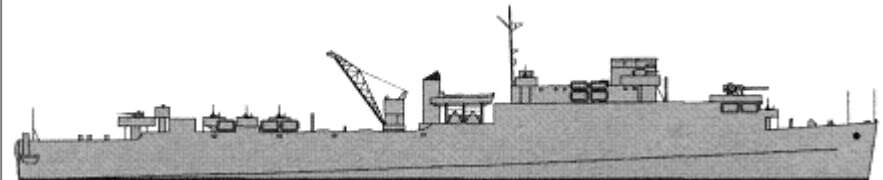
LSD	Ashland	8	LSD1	Ashland	1943		9375t, 139.5x22.0x4.8m, 2b,2quipe, 7400hp, 15.4kts, 254p; 1x1-127/38, (2x4+2x2)-40/60, 16x1-20/70; 3LCT(6), 332troops; SU radar
			LSD2	Belle Grove	1943		
			LSD3	Carter Hall	1943		
			LSD4	Epping Forest	1943		
			LSD5(A)	Gunston Hall	1943		
			LSD6	Lindenwald	1943		
			LSD7	Oak Hill	1944		
			LSD8	White Marsh	1944		
LSD	Casa Grande	13	LSD13	Casa Grande	1944		9375t, 139.5x22.0x4.8m, 2b,2gst, 7000(LSD13-21,25-27)-9000(LSD22)hp, 15.4(LSD13-21,25-27)-15.6(LSD22)kts, 254p; 1x1-127/38, (2x4+2x2)-40/60, 16x1-20/70; 3LCT(6), 332troops; SU radar
			LSD14	Rushmore	1944		
			LSD15	Shadwell	1944		
			LSD16	Cabildo	1945		
			LSD17	Catamount	1945		
			LSD18	Colonial	1945		
			LSD19	Comstock	1945		
			LSD20	Donner	1945		
			LSD21	Fort Mandan	1945		
			LSD22	Fort Marion	1946		
LSD25	San Marcos	1945					
			LST17		1943		
			LST31		1943		

LST32		1943
LST47		1943
LST50		1943
LST53		1943
LST57		1944
LST60		1944
LST(H)117		1943
LST176		1943
LST209		1943
LST218		1943
LST(H)222		1943
LST227		1943
LST230		1943
LST263		1943
LST266		1943
LST270		1943
LST(H)276		1943
LST277		1943
LST279		1943
LST281		1943
LST287		1943
LST288		1943
LST291		1943
LST306		1942
LST325		1943
LST344		1943
LST356		1942
LST389		1942
LST391		1942
LST399		1943
LST400		1943
LST456		1943
LST(H)482		1943
LST483		1943
LST(H)488		1943
LST491		1943
LST503		1943
LST504		1943
LST509		1944
LST510		1944
LST512		1944

LST515		1944
LST516		1944
LST519		1944
LST520		1944
LST521		1944
LST525		1944
LST527		1944
LST528		1944
LST529		1944
LST530		1944
LST532		1944
LST533		1944
LST535		1944
LST542		1944
LST546		1944
LST548		1944
LST550		1944
LST551		1944
LST561		1944
LST566		1944
LST572		1944
LST578		1944
LST579		1944
LST581		1944
LST583		1944
LST587		1944
LST590		1944
LST600		1944
LST601		1944
LST602		1944
LST603		1944
LST607		1944
LST611		1944
LST613		1944
LST616		1944
LST623		1944
LST625		1944
LST626		1944
LST629		1944
LST630		1944

LST	LST1	187	LST643	1944
			LST649	1944
			LST(H)652	1944
			LST657	1944
			LST664	1944
			LST685	1944
			LST689	1944
			LST692	1944
			LST694	1944
			LST715	1944
			LST722	1944
			LST(H)731	1944
			LST735	1944
			LST742	1944
			LST758	1944
			LST759	1944
			LST761	1944
			LST762	1944
			LST772	1944
			LST783	1944
			LST784	1944
			LST786	1944
			LST794	1944
			LST799	1944
			LST802	1944
			LST803	1944
			LST819	1944
			LST821	1944
LST822	1944			
LST824	1944			
LST825	1944			
LST827	1944			
LST835	1944			
LST836	1944			
LST838	1944			
LST839	1944			
LST840	1944			
LST845	1945			
LST846	1945			
LST848	1945			
LST849	1945			

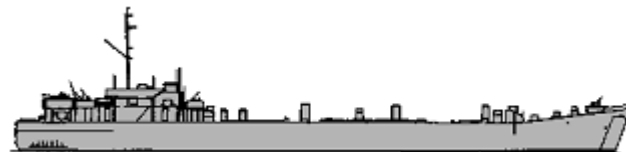

4080t, 100.0x15.2x4.3m, 2d, 1800hp, 12.1kts, 125p; (1x2+5x1)-40/60(LST1-541), (2x2+4x1)-40/60(LST542-1152), 12x1-20/70; 4LCVP, 20tanks, 163troops; SU radar

LST850		1944
LST853		1944
LST854		1944
LST855		1944
LST857		1944
LST859		1945
LST880		1945
LST883		1945
LST887		1944
LST888		1944
LST898		1944
LST900		1945
LST901		1945
LST902		1945
LST903		1945
LST904		1945
LST905		1945
LST912		1944
LST914		1944
LST928		1944
LST938		1944
LST953		1944
LST973		1945
LST975		1945
LST980		1944
LST983		1944
LST987		1944
LST988		1944
LST1010		1944
LST1032		1944
LST1038		1945
LST1041		1945
LST1048		1945
LST1064		1945
LST1066		1945
LST1067		1945
LST1068		1945
LST1069		1945
LST1071		1945
LST1072		1945

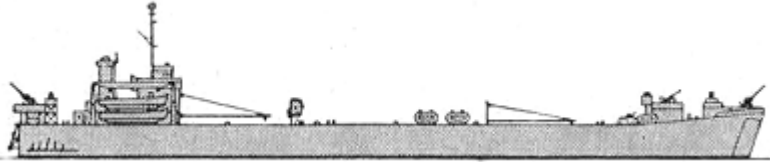
			LST1073		1945		
			LST1074		1945		
			LST1076		1945		
			LST1077		1945		
			LST1079		1945		
			LST1080		1945		
			LST1081		1945		
			LST1082		1945		
			LST1083		1945		
			LST1084		1945		
			LST1086		1945		
			LST1088		1945		
			LST1089		1945		
			LST1090		1945		
			LST1091		1945		
			LST1096		1945		
			LST1101		1945		
			LST1110		1945		
			LST1122		1945		
			LST1123		1945		
			LST1126		1945		
			LST1128		1945		
			LST1129		1945		
			LST1134		1945		
			LST1138		1945		
			LST1141		1945		
			LST1142		1945		
			LST1144		1945		
			LST1146		1945		
			LST1148		1945		
			LST1150		1945		
			LST1152		1945		
	LST1153	2	LST1153		1947		6000t, 116.4x16.5x4.4m, 2b,2gst, 6000hp, 14kts, 181p; 2x1-127/38, 2x2-40/60, 2x1-20/70; 4LCVP, 20tanks, 175troops; SU radar
			LST1154		1949		
LSV	Catskill	5	LSV1	Catskill	1944		9040t, 138.8(LSV1,2)-139.6(LSV3-5)x18.4x6.1m, 4b,2gst, 11000hp, 20.3kts, 564p; 4x1-127/38(LSV1,2), (1x2+2x1)-127/38(LSV3-5), 4x2-40/60, 20x1-20/70(LSV1,2), 6x2-20/70(LSV3-5); 14LCVP, 1LCPL(LSV1,2), 1LCPR(LCV1,2), 19-21LVT, 868troops; SU radar
			LSV2	Ozark	1944		
			LSV3	Osage	1944		
			LSV4	Saugus	1945		

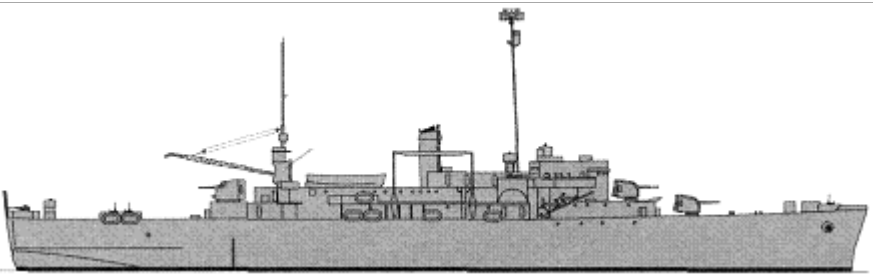
		LSV5	Monitor	1944	
		LSM17		1944	
		LSM19		1944	
		LSM30		1944	
		LSM37		1944	
		LSM45		1944	
		LSM54		1944	
		LSM57		1944	
		LSM58		1944	
		LSM84		1944	
		LSM85		1944	
		LSM96		1944	
		LSM99		1944	
		LSM101		1944	
		LSM102		1944	
		LSM104		1944	
		LSM105		1944	
		LSM106		1944	
		LSM107		1944	
		LSM108		1944	
		LSM109		1944	
		LSM110		1944	
		LSM116		1944	
		LSM118		1944	
		LSM119		1944	
		LSM120		1944	
		LSM121		1944	
		LSM125		1944	
		LSM161		1944	
		LSM167		1944	
		LSM168		1944	
		LSM175		1944	
		LSM200		1944	
		LSM204		1944	
		LSM212		1944	

LSM226		1944
LSM227		1944
LSM229		1944
LSM231		1944
LSM232		1944
LSM236		1944
LSM250		1944
LSM262		1944
LSM268		1944
LSM269		1944
LSM270		1944
LSM274		1944
LSM275		1944
LSM276		1944
LSM288		1945
LSM289		1945
LSM291		1945
LSM296		1944
LSM297		1944
LSM298		1944
LSM299		1944
LSM300		1945
LSM301		1945
LSM303		1945
LSM304		1945
LSM305		1945
LSM306		1945
LSM309		1945
LSM313		1944
LSM315		1944
LSM316		1944
LSM319		1944
LSM320		1944
LSM324		1944
LSM329		1944
LSM330		1944
LSM331		1944
LSM332		1944
LSM335		1944
LSM341		1945
LSM343		1945

			LSM354		1944
			LSM355		1944
			LSM357		1944
			LSM358		1945
			LSM359		1945
LSM	LSM1	159	LSM360		1945
			LSM362		1945
			LSM364		1945
			LSM365		1945
			LSM366		1945
			LSM367		1945
			LSM369		1945
			LSM370		1945
			LSM371		1945
			LSM372		1945
			LSM373		1945
			LSM378		1945
			LSM389		1945
			LSM390		1945
			LSM392		1945
			LSM394		1945
			LSM395		1945
			LSM396		1945
			LSM397		1945
			LSM398		1945
			LSM399		1945
			LSM413		1945
			LSM415		1944
			LSM416		1944
			LSM418		1944
			LSM419		1944
			LSM421		1944
			LSM422		1944
			LSM424		1945
			LSM429		1945
			LSM441		1945
			LSM444		1945
			E-LSM445		1945
			E-LSM446		1945
			LSM448		1945



1095t, 62.0x10.5x2.1m, 2d, 2800hp, 13.2kts, 60p; 1x2-40/60, 4x1-20/70; 6LVT, 54troops; SU radar

LSM455		1945
LSM462		1945
LSM463		1945
LSM469		1945
LSM471		1945
LSM472		1945
LSM473		1945
LSM474		1945
LSM476		1945
LSM477		1945
LSM478		1945
LSM479		1945
LSM480		1945
LSM481		1945
LSM483		1945
LSM484		1945
LSM488		1945
LSM490		1945
LSM491		1945
LSM492		1945
LSM493		1945
LSM494		1945
LSM495		1945
LSM496		1945
LSM497		1945
LSM498		1945
LSM499		1945
LSM500		1945
LSM537		1945
LSM538		1945
LSM539		1945
LSM540		1945
LSM541		1945
LSM542		1945
LSM543		1945
LSM544		1946
LSM545		1946
LSM546		1946
LSM547		1946
LSM548		1946
LSM553		1945

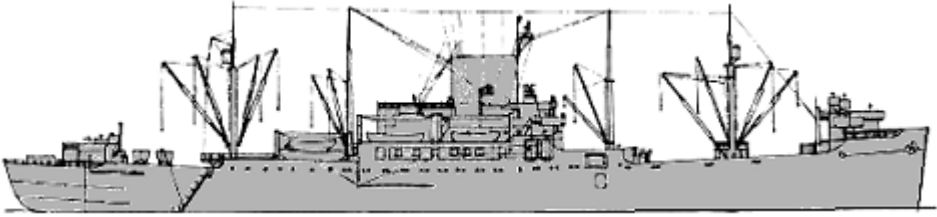
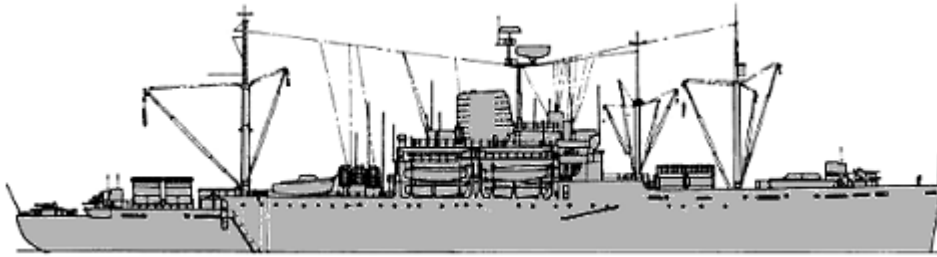
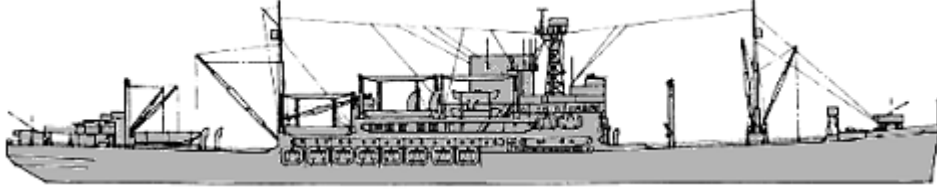
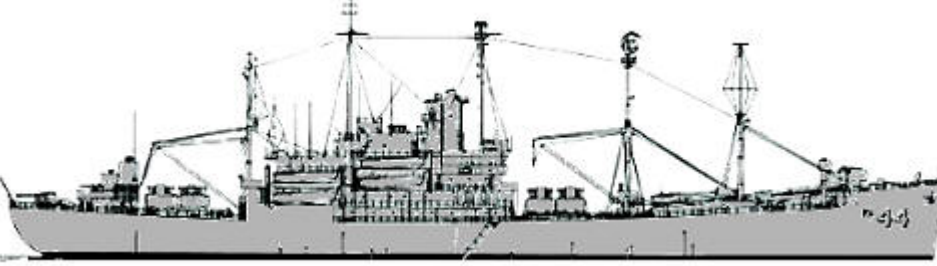
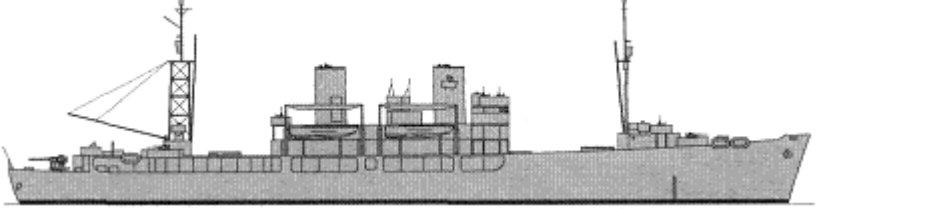
			LSM554		1945		
			LSM555		1945		
			LSM556		1945		
			LSM557		1945		
			LSM558		1945		
President Jackson	4	T-APA18	President Jackson	1940		16175t, 149.7x21.2x8.1m, 2b,1gst, 8500hp, 17kts, 512p; 4x1-76/50, (2x2+2x1)-40/60, 12x1-20/70; 4LCM(6), 23LCVP, 2LCPL, 1LCPR, 3500t cargo, 1379troops; SG radar	
		APA19	President Adams	1941			
		APA20	President Hayes	1941			
		T-APA30	Thomas Jefferson	1941			
Arthur Middleton	3	APA25	Arthur Middleton	1942		18000t, 149.1x21.3x8.3m, 2b,1gst, 8500hp, 16.5kts, 578p; 1x1-127/38, 4x1-76/50, 2x2-40/60, 10x1-20/70; 4LCM(6), 18LCVP, 3LCPL, 2LCPR, 2700t cargo, 1240troops; SG radar	
		APA26	Samuel Chase	1942			
		APA27	George Clymer	1942			
Crescent City	3	APA28	Charles Carroll	1942		14247t, 151.8x17.2x8.1m, 2b,1gst, 7800hp, 16kts, 534p; 1x1-127/38, 4x1-76/50, (1x2+1x1)-40/60, 11x2-20/70; 4LCM(6), 20LCVP, 3LCPL, 2LCPR, 2700t cargo, 1237troops; SG radar	
		APA31	Monrovia	1942			
		APA32	Calvert	1942			
Bayfield	6	APA33	Bayfield	1943		16100t, 150.0x21.2x8.1m, 2b,1gst, 8500hp, 18kts, 575p; 2x1-127/38, 4x2-40/60, 18x1-20/70; 4LCM(6), 19LCVP, 3LCPL, 2LCPR, 4700t cargo, 1875troops; SU radar	
		APA36	Cambria	1943			
		APA37	Cavalier	1943			
		APA38	Chilton	1943			
		APA44	Fremont	1943			
		APA45	Henrico	1943			
Gilliam	3	APA63	Bladen	1944		7080t, 129.9x17.7x4.7m, 2b,2stg,2em, 6000hp, 18kts, 283p; 1x1-127/38, 4x2-40/60, 10x1-20/70; 13LCVP, 1LCPL, 1LCPR, 600t cargo, 986troops; SU radar	
		APA67	Burleson	1944			
		APA87	Niagara	1945			
			APA128	Arenac	1944		
			APA132	Barnwell	1945		
			APA136	Botetourt	1945		
			APA140	Brookings	1944		

LPA

Haskell

56

APA144	Clinton	1945
APA148	Crockett	1945
APA152	Latimer	1944
APA156	Mellette	1944
APA160	Deuel	1944
APA164	Edgecombe	1944
APA168	Gage	1944
APA176	Kershaw	1944
APA180	Lavaca	1944
APA188	Olmsted	1944
APA192	Rutland	1944
APA193	Sanborn	1944
APA194	Sandoval	1944
APA195	Lenawee	1944
APA196	Logan	1944
APA197	Lubbock	1944
APA198	McCracken	1944
APA199	Magoffin	1944
APA201	Menard	1944
APA202	Menifee	1944
APA203	Meriwether	1944
APA204	Sarasota	1944
APA205	Sherburne	1944
APA206	Sibley	1944
APA207	Miffin	1944
APA208	Talladega	1944
APA209	Tazewell	1944
APA210	Telfair	1944
APA211	Missoula	1944
APA212	Montrose	1944
APA213	Mountrail	1944
APA214	Natrona	1944
APA215	Navarro	1944
APA216	Neshoba	1944
APA217	New Kent	1944
APA218	Noble	1944
APA219	Okaloosa	1944
APA220	Okanogan	1944
APA221	Oneida	1944
APA222	Pickaway	1944
APA224	Randall	1944

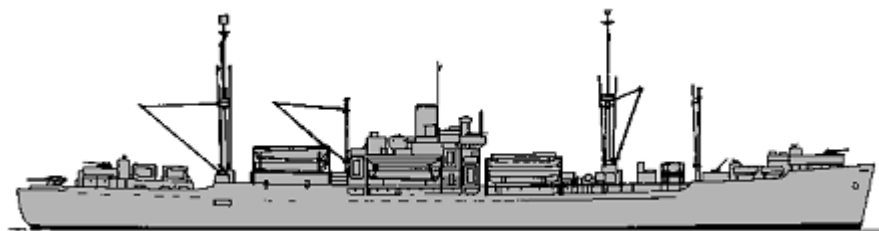

14880t, 138.7x18.9x7.3m, 2b,1gst, 8500hp, 16.5kts, 536p; 1x1-127/38, (1x4+4x2)-40/60, 10x1-20/70; 2LCM(6), 22LCVP, 1LCPL, 1LCPR, 1800t cargo, 1596troops; SU radar

APA226	Rawlins	1944
APA227	Renville	1944
APA228	Rockbridge	1944
APA229	Rockingham	1944
APA230	Rockwell	1944
APA232	San Saba	1944
APA235	Bottineau	1944
APA236	Bronx	1945
APA237	Bexar	1945
APA238	Dane	1945
APA239	Glynn	1945

APD37	Charles Lawrence	1943
APD38	Daniel T. Griffin	1943
APD39	Barr	1944
APD40	Bowers	1944
APD42	Gantner	1943
APD43	George W. Ingram	1943
APD44	Ira Jeffery	1943
APD45	Lee Fox	1943
APD46	Amesbury	1943
APD48	Blessman	1943
APD49	Joseph E. Campbell	1943
APD50	Sims	1943
APD51	Hopping	1943
APD52	Reeves	1943
APD53	Joseph C. Hubbard	1944
APD55	Laning	1943
APD56	Loy	1943
APD57	Barber	1943
APD59	Newman	1943
APD60	Liddle	1943
APD61	Kephart	1944
APD62	Cofer	1944
APD63	Lloyd	1944
APD65	Burke	1943
APD66	Enright	1943
APD69	Yokes	1944

LPR

Charles
Lawrence

92

APD70	Pavlic	1944
APD71	Odum	1945
APD72	Jack C. Robinson	1945
APD73	Bassett	1945
APD74	John P. Gray	1945
APD75	Weber	1944
APD76	Schmitt	1943
APD77	Frament	1943
APD78	Bull	1943
APD79	Bunch	1943
APD80	Hayter	1944
APD81	Tatum	1943
APD84	Haines	1943
APD85	Runels	1944
APD86	Hollis	1944
APD87	Crosley	1944
APD88	Cread	1944
APD89	Ruchamkin	1944
APD90	Kirwin	1944
APD91	Kinzer	1944
APD92	Register	1945
APD93	Brock	1945
APD94	John Q. Roberts	1945
APD95	William M. Hobby	1945
APD96	Ray K. Edwards	1945
APD97	Arthur L. Bristol	1945
APD98	Truxton	1945
APD99	Upham	1945
APD100	Ringness	1944
APD101	Knudson	1944
APD102	Rednour	1944
APD103	Tollberg	1945
APD104	William J. Pattison	1945
APD105	Myers	1945
APD106	Walter B. Cobb	1945

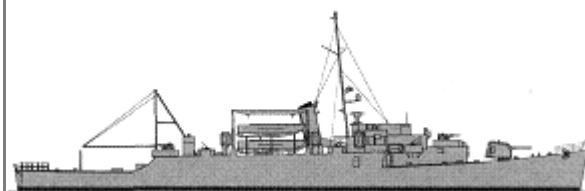

2114t, 93.3x11.3x3.8m, 2b,2stg,2em, 12000hp, 23.6kts, 203p; 1x1-127/38, 3x2-40/60, 6x1-20/70, 2DCR; 4LCVP, 162troops; SA, SU radars, sonar

APD107	Earle B. Hall	1945
APD108	Harry L. Corl	1945
APD109	Belet	1945
APD110	Julius A. Raven	1945
APD111	Walsh	1945
APD112	Hunter Marshall	1945
APD113	Earhart	1945
APD114	Walter S. Gorka	1945
APD115	Rogers Blood	1945
APD116	Francovich	1945
APD117	Joseph M. Auman	1945
APD118	Don O. Woods	1945
APD119	Beverly W. Reid	1945
APD120	Kline	1944
APD121	Raymond W. Herndon	1944
APD122	Scribner	1944
APD123	Diachenko	1944
APD124	Horace A. Bass	1944
APD125	Wantuck	1944
APD126	Gosselin	1944
APD127	Begor	1945
APD128	Cavallaro	1945
APD129	Donald W. Wolf	1945
APD130	Cook	1945
APD131	Walter X. Young	1945
APD132	Balduck	1945
APD133	Burdo	1945
APD134	Kleinsmith	1945
APD135	Weiss	1945
APD136	Carpellotti	1945
APD139	Bray	1944
AKA3	Bellatrix	1942

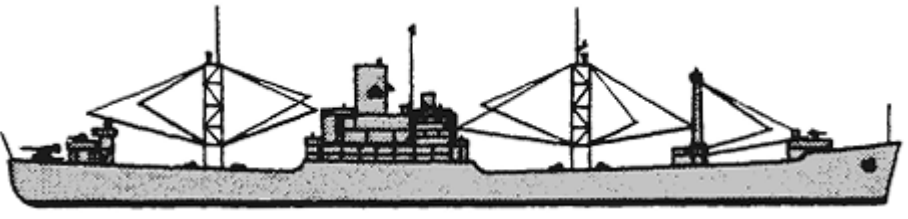
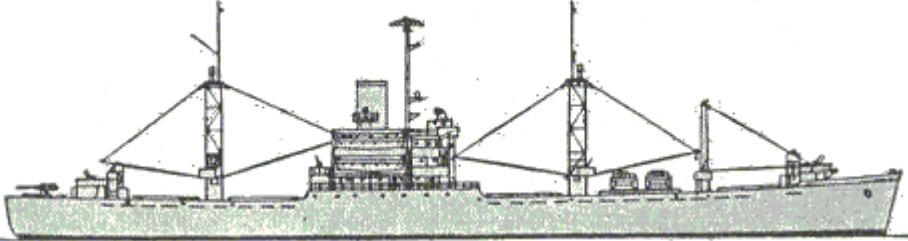
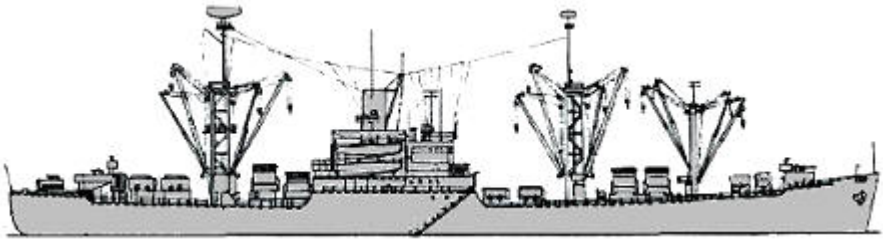
LKA	Procyon	5	AKA4	Electra	1942		13910t, 143.0x19.2x7.8m, 1d(AKA3,4)-2b,1gst(AKA12-14), 6000hp, 16.5kts, 412p; 1x1-127/38, 4x1-76/50(AKA3,4), 4x2-40/60(AKA12-14), 18x1-20/70; 6LCM(6), 2LCM(3)(AKA3,4), 3LCM(3)(AKA12-14), 10LCVP, 1LCPL, 4515(AKA3,4)-4605(AKA12-14)t cargo, 54(AKA3,4)-190(AKA12-14)troops; SU radar
			AKA12	Libra	1942		
			T-AKA13	Titania	1942		
			T-AKA14	Oberon	1942		
LKA	Andromeda	25	AKA15	Andromeda	1943		13910t, 139.9x19.2x7.9m, 2b,1gst, 6000hp, 16.5kts, 404p; 1x1-127/38, 4x2-40/60, 18x1-20/70; 6LCM(6), 2LCM(3), 13LCVP, 1LCPL, 4900t cargo, 78troops; SU radar
			AKA19	Thuban	1943		
			AKA20	Virgo	1943		
			T-AKA53	Achernar	1944		
			AKA54	Algol	1943		
			T-AKA55	Alshain	1944		
			AKA56	Arneb	1943		
			AKA57	Capricornus	1943		
			T-AKA58	Chara	1944		
			AKA59	Diphda	1944		
			T-AKA60	Leo	1944		
			AKA61	Muliphen	1944		
			AKA88	Uvalde	1944		
			AKA89	Warrick	1944		
			AKA90	Whiteside	1944		
			AKA91	Whitley	1944		
			AKA92	Wyandot	1944		
			AKA93	Yancey	1944		
			AKA94	Winston	1945		
			AKA95	Marquette	1945		
AKA96	Mathews	1945					
AKA97	Merrick	1945					
AKA98	Montague	1945					
AKA99	Rolette	1945					
T-AKA100	Oglethorpe	1945					
LKA	Rankin	6	AKA103	Rankin	1945		13910t, 139.9x19.2x7.9m, 2b,1gst, 6000hp, 16.5kts, 404p; 1x1-127/38, 4x2-40/60, 16x1-20/70; 6LCM(6), 2LCM(3), 13LCVP, 1LCPL, 5275t cargo, 62troops; SU radar
			AKA104	Seminole	1945		
			AKA105	Skagit	1945		
			AKA106	Union	1945		
			AKA107	Vermilion	1945		
			AKA108	Washburn	1945		
LKA	Artemis	1	AKA28	Hydrus	1944		6740t, 129.9x17.7x4.7m, 2b,2stg,2em, 6000hp, 18kts, 303p; 1x1-127/38, 4x2-40/60, 10x1-20/70; 13LCVP, 2LCM(3), 1LCPL, 2900t cargo, 252troops; SU radar

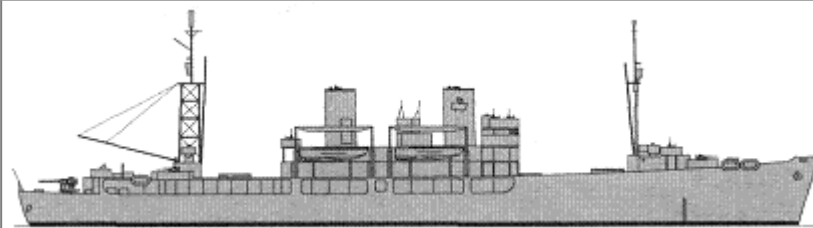

LSIL76		1943
LSIL367		1943
LSIL476		1943
LSIL485		1943
LSIL504		1943
LSIL544		1944
LSIL575		1944
LSIL627		1944
LSIL628		1944
LSIL633		1944
LSIL638		1944
LSIL652		1944
LSIL653		1944
LSIL654		1944
LSIL655		1944
LSIL656		1944
LSIL664		1944
LSIL674		1944
LSIL679		1944
LSIL691		1944
LSIL693		1944
LSIL694		1944
LSIL695		1944
LSIL696		1944
LSIL698		1944
LSIL699		1944
LSIL700		1944
LSIL701		1944
LSIL702		1944
LSIL703		1944
LSIL709		1944
LSIL710		1944
LSIL715		1944
LSIL768		1944
LSIL774		1944

			LSIL775		1944
			LSIL776		1944
			LSIL777		1944
			LSIL778		1944
			LSIL782		1944
			LSIL783		1944
			LSIL786		1944
			LSIL788		1944
			LSIL789		1944
			LSIL790		1944
			LSIL791		1944
			LSIL792		1944
			LSIL793		1944
			LSIL799		1944
			LSIL818		1944
			LSIL868		1944
LCI(L)	LCI(L)1	103	LSIL869		1944
			LSIL870		1944
			LSIL871		1944
			LSIL872		1944
			LSIL873		1944
			LSIL874		1944
			LSIL875		1944
			LSIL882		1944
			LSIL883		1944
			LSIL884		1944
			LSIL944		1944
			LSIL947		1944
			LSIL952		1944
			LSIL954		1944
			LSIL962		1944
			LSIL963		1944
			LSIL966		1944
			LSIL969		1944
			LSIL970		1944
			LSIL971		1944
			LSIL973		1944
			LSIL976		1944
			LSIL978		1944
			LSIL982		1944
			LSIL985		1944

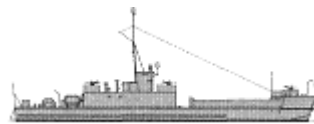

385t, 48.9x7.2x1.6m, 8d(2), 2320hp, 15.5kts, 29p; 5x1-20/70; 209troops; SO radar

LSIL989		1944
LSIL994		1944
LSIL995		1944
LSIL996		1944
LSIL998		1944
LSIL1000		1944
LSIL1001		1944
LSIL1008		1944
LSIL1017		1944
LSIL1021		1944
LSIL1022		1944
LSIL1032		1944
LSIL1052		1944
LSIL1053		1944
LSIL1071		1944
LSIL1080		1944
LSIL1081		1944
LSIL1082		1944
LSIL1083		1944
LSIL1084		1944
LSIL1086		1944
LSIL1090		1944
LSIL1091		1944
LSIL1092		1944
LSIL1093		1944
LSIL1097		1944
LSIL1098		1944
LSU509		1943
LSU520		1943
LSU524		1943
LSU529		1943
LSU550		1943
LSU562		1943
LSU592		1943
LSU600		1943
LSU629		1944
LSU637		1944
LSU638		1944
LSU644		1944
LSU646		1944

LSU653		1944
LSU666		1944
LSU677		1944
LSU686		1944
LSU709		1944
LSU716		1944
LSU742		1944
LSU743		1944
LSU763		1943
LSU764		1943
LSU776		1943
LSU778		1944
LSU783		1944
LSU788		1944
LSU827		1944
LSU840		1944
LSU851		1943
LSU852		1944
LSU869		1944
LSU877		1944
LSU917		1943
LSU960		1944
LSU971		1944
LSU973		1944
LSU979		1944
LSU980		1944
LSU989		1944
LSU990		1944
LSU1009		1944
LSU1056		1944
LSU1082		1944
LSU1085		1944
LSU1086		1944
LSU1124		1944
LSU1126		1944
LSU1136		1944
LSU1155		1944
LSU1156		1944
LSU1157		1944
LSU1158		1944
LSU1159		1944

LCU LCT(6) 87

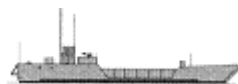

320t, 36.3x10.0x1.2m, 3d, 675hp, 8kts, 13p; 2x1-20/70; 4tanks; SO radar

LSU1160		1944
LSU1161		1944
LSU1162		1944
LSU1165		1944
LSU1195		1944
LSU1203		1944
LSU1224		1944
LSU1229		1944
LSU1232		1944
LSU1236		1944
LSU1250		1944
LSU1273		1944
LSU1283		1944
LSU1286		1944
LSU1317		1944
LSU1362		1944
LSU1363		1944
LSU1374		1944
LSU1376		1944
LSU1378		1944
LSU1379		1944
LSU1382		1944
LSU1384		1944
LSU1385		1944
LSU1386		1944
LSU1388		1944
LSU1398		1944
LSU1411		1944
LSU1430		1944
LSU1446		1944
LSU1451		1944
LSU1459		1944
LSU1462		1944
LSM(R)401		1945
LSM(R)402		1945
LSM(R)403		1945
LSM(R)404		1945
LSM(R)405		1945
LSM(R)406		1945
LSM(R)407		1945

LSM(R)401 48

LSM(R)408		1945
LSM(R)409		1945
LSM(R)410		1945
LSM(R)411		1945
LSM(R)412		1945
LSM(R)501		1945
LSM(R)502		1945
LSM(R)503		1945
LSM(R)504		1945
LSM(R)505		1945
LSM(R)506		1945
LSM(R)507		1945
LSM(R)508		1945
LSM(R)509		1945
LSM(R)510		1945
LSM(R)511		1945
LSM(R)512		1945
LSM(R)513		1945
LSM(R)514		1945
LSM(R)515		1945
LSM(R)516		1945
LSM(R)517		1945
LSM(R)518		1945
LSM(R)519		1945
LSM(R)520		1945
LSM(R)521		1945
LSM(R)522		1945
LSM(R)523		1945
LSM(R)524		1945
LSM(R)525		1945
LSM(R)526		1945
LSM(R)527		1945
LSM(R)528		1945
LSM(R)529		1945
LSM(R)530		1945
LSM(R)531		1945
LSM(R)532		1945
LSM(R)533		1945
LSM(R)534		1945
LSM(R)535		1945
LSM(R)536		1945



1175t, 62.0x10.5x2.1m, 2d, 2800hp, 13kts, 143p; 1x1-127/38, 2x2-40/60, 4x2-20/70, 4x1-107/10mortars, 5x2-127rockets; SU radar

LFR





LSSL1		1944
LSSL2		1944
LSSL3		1944
LSSL4		1944
LSSL6		1944
LSSL9		1944
LSSL10		1944
LSSL11		1944
LSSL12		1944
LSSL13		1944
LSSL14		1944
LSSL16		1944
LSSL17		1944
LSSL18		1944
LSSL19		1944
LSSL20		1944
LSSL21		1944
LSSL22		1944
LSSL23		1944
LSSL24		1944
LSSL25		1944
LSSL27		1944
LSSL28		1944
LSSL29		1944
LSSL30		1944
LSSL32		1944
LSSL34		1944
LSSL35		1944
LSSL36		1944
LSSL38		1944
LSSL52		1944
LSSL53		1944
LSSL54		1944
LSSL55		1944
LSSL56		1944
LSSL57		1944
LSSL58		1944
LSSL59		1944
LSSL60		1944
LSSL61		1944

LCS(L)(3) 106

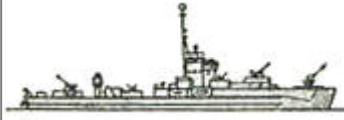

LSSL62		1944
LSSL63		1944
LSSL64		1944
LSSL65		1944
LSSL67		1945
LSSL68		1945
LSSL69		1945
LSSL70		1945
LSSL71		1945
LSSL72		1945
LSSL73		1945
LSSL74		1945
LSSL75		1945
LSSL76		1945
LSSL77		1945
LSSL78		1945
LSSL79		1944
LSSL80		1944
LSSL81		1944
LSSL82		1944
LSSL83		1944
LSSL84		1944
LSSL85		1944
LSSL86		1944
LSSL87		1944
LSSL88		1944
LSSL89		1944
LSSL90		1944
LSSL91		1945
LSSL92		1945
LSSL93		1945
LSSL94		1945
LSSL95		1945
LSSL96		1945
LSSL97		1945
LSSL98		1945
LSSL99		1945
LSSL100		1945
LSSL101		1945
LSSL102		1945
LSSL103		1945

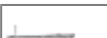

387t, 48.2x7.2x1.7m, 8d(2), 2320hp, 15.5kts, 71p; 3x2-40/60, 4x1-20/70, 10x1-127rocket launchers; SU radar

			LSSL104		1945		
			LSSL105		1945		
			LSSL106		1945		
			LSSL107		1945		
			LSSL108		1945		
			LSSL109		1944		
			LSSL110		1944		
			LSSL111		1944		
			LSSL112		1944		
			LSSL113		1944		
			LSSL114		1944		
			LSSL115		1944		
			LSSL116		1944		
			LSSL117		1944		
			LSSL118		1944		
			LSSL119		1944		
			LSSL120		1944		
			LSSL121		1944		
			LSSL122		1944		
			LSSL124		1944		
			LSSL125		1944		
			LSSL126		1944		
			LSSL128		1944		
			LSSL129		1944		
			LSSL130		1945		
LCI(G)	LCI(G)	1	LSIG543		1944		385t, 48.9x7.2x1.6m, 8d(2), 2320hp, 15.5kts, 70p; 2x1-40/60, 3x1-20/70, 6x1-12.7/90, 10x1-127rockets; SO radar
LCI(M)	LCI(M)	1	LSIM596		1944		385t, 48.9x7.2x1.6m, 8d(2), 2320hp, 15.5kts, 53p; 1x1-40/60, 3x1-107/10mortars; SO radar
LCM	LCM(3)	2000	~2000		1942-1945		52t, 15.3x4.3x1.4m, 2d, 330hp, 8kts, 4p; 2x1-12.7/90; 1tank
	LCM(6)	600	~600		1943-1945		56t, 17.1x4.3x1.2m, 2d, 450hp, 9kts, 5p; 2x1-12.7/90; 1tank
LCVP	LCVP	5800	~5800		1942-1945		13t, 11.2x3.2x0.9m, 2d, 220hp, 8kts, 3p; 2x1-12.7/90; 36troops
LCPL	LCPL	600	~600		1941-1944		8t, 11.2x3.3x1.1m, 1d, 150hp, 8kts, 3p; 36troops
LCPR	LCPR	600	~600		1942-1945		8t, 11.2x3.3x1.1m, 1d, 250hp, 11kts, 3p; 36troops

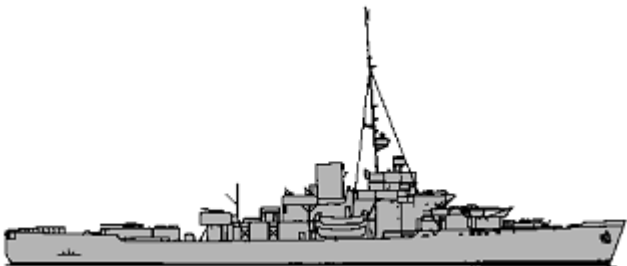
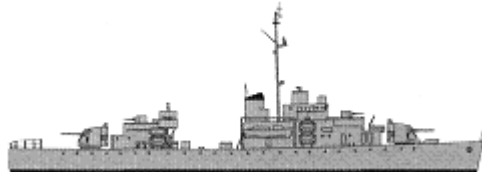
COAST GUARD

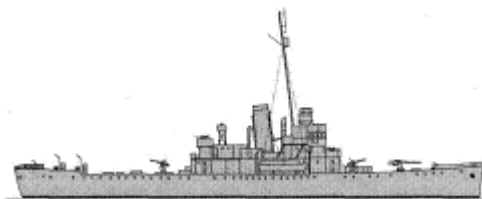
PSO	Treasury	6	WPG31	Bibb	1937		2660t, 99.7x12.5x3.8m, 2b,2gst, 5250hp, 19kts, 123p; 1x1-127/38, 1x2-40/60, 2x1-20/70(WPG31,36,37, 8x1-20/70(WPG32,33,35), 1x24-178Hedgehog, 2DCR(WPG37); radar, sonar
			WPG32	Campbell	1936		
			WPG33	Duane	1936		
			WPG35	Ingham	1936		
			WPG36	Spencer	1937		
			WPG37	Taney	1936		
	Owasco	13	WPG39	Owasco	1945		2660t, 77.7x13.1x4.9m, 2b,1stg, 1em, 4000hp, 19kts, 276p; 2x2-127/38, 2x4-40/60, 4x1-20/70, 1x24-178Hedgehog, 6DCT, 2DCR; SU, Mk25 radars, sonar
			WPG40	Winnebago	1945		
			WPG41	Chautauqua	1945		
			WPG42	Sebago	1945		
			WPG43	Iroquois	1946		
			WPG44	Wachusett	1946		
			WPG64	Escanaba	1946		
			WPG65	Winona	1946		
			WPG66	Klamath	1946		
			WPG67	Minnetonka	1946		
			WPG68	Androscoggin	1946		
			WPG69	Mendota	1945		
			WPG70	Pontchartrain	1945		
	Algonquin	2	WPG79	Onondaga	1934		1005t, 50.3x11.0x3.7m, 2b,1gst, 1500hp, 12.5kts, 61p; 2x1-76/50, 3x1-20/70, 2x4-178Mousetrap(WPG80), 4DCT, 2DCR; radar
WPG80			Tahoma	1934			
Chelan	3	WPG163	Mocoma	1932		2075t, 76.2x12.8x3.9m, 2b,1stg,1em, 3350hp, 17kts, 97p; 1x1-127/51, 3x1-76/50, 4x1-20/70; radar	
		WPG164	Tampa	1930			
		WPG321	Itasca	1930			
Barnegat	18	WAVP370	Casco	1941		2620t, 94.7x12.5x3.8m, 4dg,2em, 6080hp, 20kts, 367p; 1x1-127/38, 1x4-40/60(WAVP374), 2x2-40/60(WAVP370-373,375-384), 1x24-178Hedgehog, 4DCT; SA, SU radars, sonar	
		WAVP371	Mackinac	1942			
		WAVP372	Humboldt	1941			
		WAVP373	Matagorda	1941			
		WAVP374	Absecon	1943			
		WAVP375	Chincoteague	1943			
		WAVP376	Coos Bay	1943			
		WAVP377	Rockaway	1943			
		WAVP378	Half Moon	1943			
		WAVP379	Unimak	1943			

			WPC111	Nemesis	1934		
			WPC112	Nike	1934		
			WPC113	Pandora	1934		
			WPC114	Perseus	1932		
			WPC116	Triton	1934		
PB	83ft	~200			1941-1944		45t, 25.3x4.9x1.4m, 2pe, 1200hp, 20.5kts, 10p; 1x1-20/70, 2x4-178Mousetrap, 4DCR

© Ivan Gogin, 2015



[home](#)[World navies yesterday](#)[1950](#)

Uruguay 01 January 1950

PRINCIPAL SURFACE COMBATANTS

DD	Uruguay	1	1	Uruguay	1910		1400t, 85.0ppx9.4x3.6m, 4b,2vte, 5700hp, 23kts, 125p; 17deck; 2x1-120/45, 4x1-76/40, 6x1-37/40, 2x1-450TT
----	---------	---	---	---------	------	--	---

PATROL AND COASTAL COMBATANTS



APS	-	1	1	18 de Julio	1884		678t
PC	PC 173ft	1	B1	Maldonado	1943		330t, 52.9x7.1x2.4m, 2d, 2880hp, 21kts, 65p; 1x1-76/50, 1x1-40/60, 3x1-20/70, 2x4-178 Mousetrap ASWRL, 2dct, 2dcr; SF radar, sonar
PB	Paysandú	3	A1	Paysandú	1936		180t, 41.9x5.8x1.7m, 2d, 1000hp, 17kts, 51p; 2x1-76/40, 2x1-47/40
			A2	Salto	1936		
			A3	Río Negro	1936		
	AVR 63ft	1	AR1		1944	No picture	34t, 19.2x4.6x1.2m, 2d, 1260hp, 33.5kts, 8p; 2x2-12.7

© Ivan Gogin, 2016

[home](#)[World navies yesterday](#)[1950](#)

Venezuela 01 January 1950

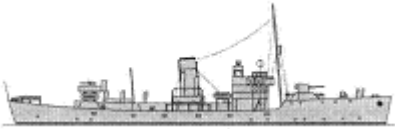
PRINCIPAL SURFACE COMBATANTS

FS	Flower	5	1	Constitución	1941		1280t, 62.5x10.1x4.8m, 2b,1vte, 2750hp, 16.5kts, 109p; 1x1-102/45, 4x1-20/70, 4dct, 2dcr; type 286, 290 radars, sonar
			2	Federación	1941		
			3	Independencia	1941		
			4	Patria	1941		
			5	Victoria	1940		
Ostia	2	1	General Soubllette	1926		850t, 62.2x8.7x2.6m, 2b,2vte, 1500hp, 15kts, 66p; 2x1-102/35, 1x1-76/40	
			2	General Urdaneta			1926

PATROL AND COASTAL COMBATANTS

PB	CG 83ft	4	CS1- 4	CS1 Antonio Diaz, CS2 Brión, CS3 Briceño Méndez, CS4 Arismendi	1941- 1944		45t, 25.3x4.9x1.4m, 2pe, 1200hp, 20.5kts, 10p; 1x1-20/70, 2x4-178 Mousetrap ASWRL, 4dcr; SO radar, sonar
----	------------	---	-----------	--	---------------	---	--

AMPHIBIOUS

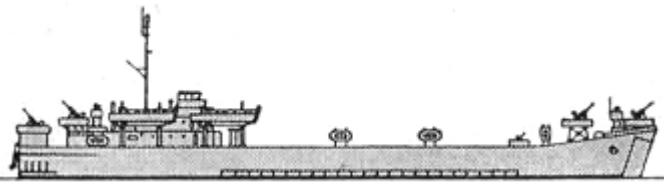

LST	LST1	1	T11	Capana	1944		4080t, 100.0x15.2x4.3m, 2d, 1800hp, 12.1kts, 125p; (2x2+4x1)-40/60, 12x1-20/70; 4 LCVP, 20tanks, 163troops; SO radar
-----	------	---	-----	--------	------	--	--

© Ivan Gogin, 2016



[home](#)[World navies yesterday](#)[1950](#)

Yugoslavia 01 January 1950

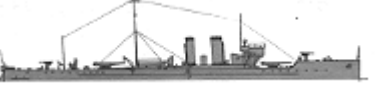
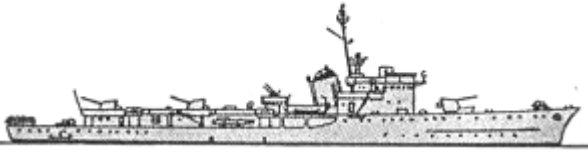

SUBMARINES

SS	Hrabri	1	P801	Tara	1928		975/1164t, 72.1x7.3x4.0m, 2d/em, 2400/1600hp, 15.7/10kts, 47p, 50m; 2x1-102/40, 1x1-13.2, 6-533TT
	Flutto	1	P802	Sava	1943		930/1093t, 63.2x7.0x4.9m, 2d/em, 2400/800hp, 16/8kts, 50p, 120m; 1x1-100/47, 6-533TT; sonar
SSX	CB	1	P901	Mališan	1943		35/44t, 15.0x3.0x2.1m, 1d/em, 80/50kts, 7.5/7kts, 4p; 2-450TT

PRINCIPAL SURFACE COMBATANTS

FS	74T	1	T1	Goleshnitsa	1914		320t, 58.2x5.7x1.5m, 2b,2st, 5000hp, 28kts, 52p; 2x1-66/50, 2x2-450TT
	82F	1	T5	Tser	1915		330t, 58.8x5.8x1.5m, 2b,2gst, 5000hp, 28kts, 52p; 2x1-66/50, 2x2-450TT
	Ciclone	2	RE51	Triglav	1943		1683t, 87.8x9.9x3.8m, 2b,2gst, 16000hp, 26kts, 177p; 3x1-100/47(51), 2x1-100/47(52), (3x2+5x1)-20/70(51), (4x2+2x1)-20/70(52), 2x2-450TT, 4dct, 20mines(51); radars, sonar
			RE52	Biokovo	1943		
Ariete	2	RE53	Durmitor	1943		1110t, 83.5x8.6x3.2m, 2b,2gst, 22000hp, 31.5kts, 150p; 2x1-100/47, 3x1-40/60(54), 3x2-20/70(53), 4x1-20/65(53), 2x3-450TT(53), 2dct, 28mines(54); radars, sonar	
		RE54	Uchka	1949			

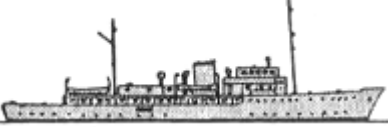
PATROL AND COASTAL COMBATANTS



PS	Beli Orao	1	1	Jadranka	1940		660t, 65.0x8.1x2.8m, 2d, 1900hp, 18kts; 2x1-40/60
	Orjen	2	TČ5	Durmitor	1937		62t, 28.0x4.3x1.5m, 3d/1pe, 3300hp, 31kts, 16p; 1x1-40/60, 1x1-15, 2-550TT, 2dcr

PT			TČ6	Kajmakčalan	1938		
	Higgins 78ft	7	MTP1-7		1943		54t, 24.8x6.1x1.6m, 3pe, 4050hp, 41kts, 17p; 1x1-40/60, 2x1-20/70, 2x2-12.7, 2-450TT; SO radar
PR	RPČ200	2	RPČ200, 201		1949	No picture	30t, 15kts; 2x1-76/50

AMPHIBIOUS

LCU	MZ	2	D206	1942		239t, 47.0x6.5x1.0m, 3d, 450hp, 11kts, 13p; 1x1-76/40, 2x1-20/65; 65t of cargo or 200troops
			D219	1942		
LCU	MFP-D	3	D203	1945		239t, 49.8x6.6x1.4m, 3d, 375hp, 10.3kts, 17p; 1x1-75/34, 1x1-37/83, 2x1-20/65; 140t of cargo or 200troops or 3tanks
			D204	1945		
			D205	1945		

MINE WARFARE

MSO	M1916	1	1	Zelengora	1918		590t, 59.6x7.3x2.2m, 2b,2vte, 1840hp, 16kts, 51p; 2x1-83/52, 24mines, minesweeping gear
MSI	MT131	3	M1	Meljine	1931		115-128t, 30.1x6.7x1.7m, 1b,2vte, 280hp, 11.6kts, 27p; 1x1-47/44, 34mines or minesweeping gear
			M2	Marjan	1931		
			M3	Mljet	1931		
MSI	RD	7	ML301		1917		196-201m, 35.3-36.5x5.8x2.0-2.1m, 1b,1vte, 800-970hp, 10-11kts, 22p; 1x1-76/40, minesweeping gear
			ML302		1917		
			ML303		1918		
			ML304		1918		
			ML305		1918		
			ML306		1918		
			ML307		1919		