

[home](#)

# THE NAVAL BALANCE 1940

## Navies of the world

01/01/1940

1. *United Kingdom* - 2565 tt; 2. *USA* - 1752 tt; 3. *Japan* - 1366 tt; 4. *France* - 920 tt; 5. *Italy* - 653 tt; 6. *Germany* - 636 tt; 7. *Soviet Union* - 429 tt; 8. *Spain* - 142 tt; 9. *Argentina* - 142 tt; 10. *Netherlands* - 118 tt



[ARGENTINA](#)

[AUSTRALIA](#)

[BELGIUM](#)

[BRAZIL](#)

[BULGARIA](#)

[BURMA](#)

[CANADA](#)

[CHILE](#)

[CHINA](#)

[COLOMBIA](#)

[CUBA](#)

[DENMARK](#)

[DOMINICAN REPUBLIC](#)

[ECUADOR](#)

[EGYPT](#)

[ESTONIA](#)

[FINLAND](#)

[FRANCE](#)

[GERMANY](#)

[GREECE](#)

[HUNGARY](#)

[ICELAND](#)

[INDIA](#)

[IRAN](#)

[IRAQ](#)

[IRELAND](#)

[ITALY](#)

[JAPAN](#)

[LATVIA](#)

[LITHUANIA](#)

[MANCHUKUO](#)

[MEXICO](#)

[NETHERLANDS](#)

[NEW ZEALAND](#)

[NORWAY](#)

[PARAGUAY](#)

[PERU](#)

[PHILIPPINES](#)

[POLAND](#)

[PORTUGAL](#)

[ROMANIA](#)

[SOUTH AFRICA](#)

[SOVIET UNION](#)

[SPAIN](#)

[SWEDEN](#)

[THAILAND](#)

[TURKEY](#)

[UNITED KINGDOM](#)

[UNITED STATES OF AMERICA](#)

[URUGUAY](#)

[VENEZUELA](#)

[YUGOSLAVIA](#)

**1576512**

[Website Hit Counter](#)



[home](#)[World navies yesterday](#)[1940](#)

# Argentina 01 January 1940

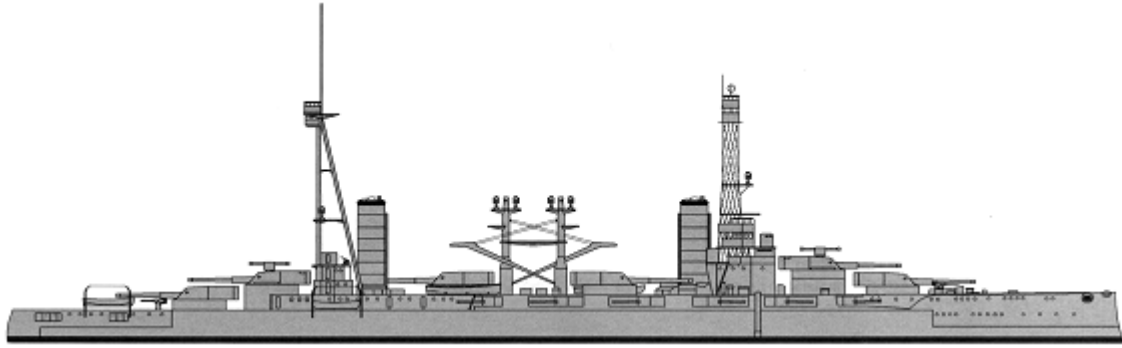
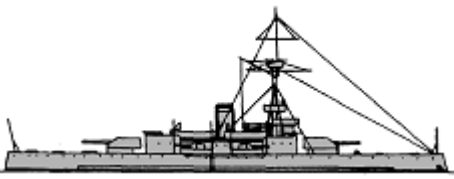
## BATTLESHIPS



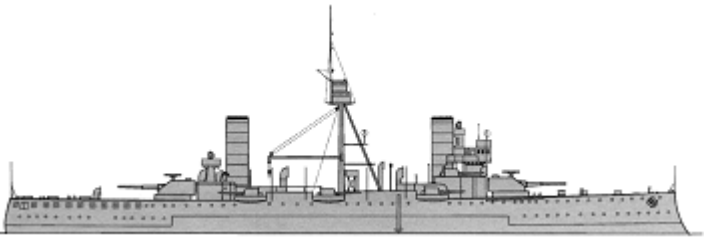

BB	Rivadavia	1	Rivadavia	1914		<p>30600t, 181.3x30.0x8.5m, 18b,3gt, 45000hp, 20kts, 1130p;280belt (76+38)deck, 305turrets, 305CT; 6x2-305/50, 12x1-152/50, 4x1-76/50, 2-533TT</p>
		2	Moreno	1915		
BC	Nueve de Julio	1	Libertad	1892		<p>2595t, 70.1ppx13.1x4.0m, 4b,2vte, 2800hp, 14kts, 230p; steel: 203belt, 37deck, 127turrets, 102CT; 2x1-240/35, 4x1-120/40, 4x1-40/39</p>
		2	Independencia			

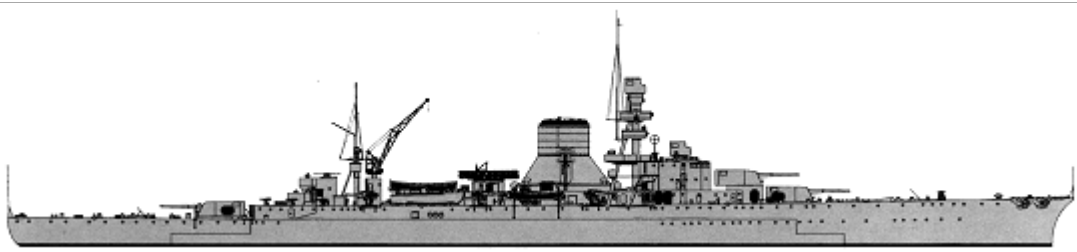
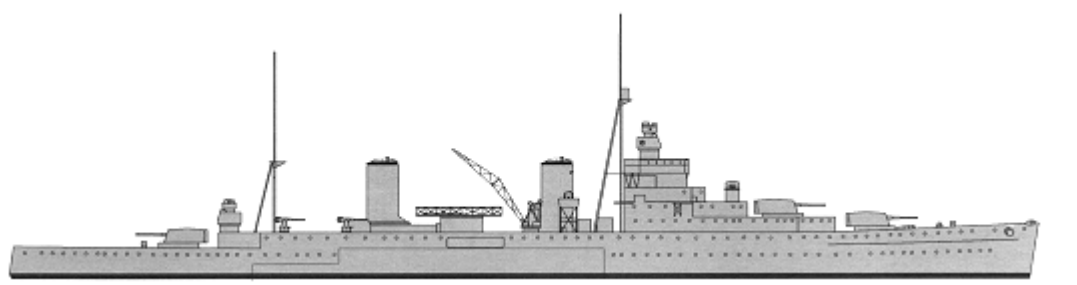
## CRUISERS

CA	Garibaldi	1	1	Pueyrredon	1898		<p>6775t, 111.7x18.2x7.1m, 8b,2vte, 13000hp, 17kts, 500-540hp; 150belt, 37deck, 150turrets, 150CT; 2x1-254/40, 8x1-152/40, 2x1-57/40</p>
	Veinticinco de Mayo	2	Almirante Brown	1931			
3		Veinticinco de Mayo	1931	<p>9000t, 170.8x17.8x4.7m, 6b,2gt, 85000hp, 32kts, 780p; 70belt, 25deck, 50turrets, 65CT; 3x2-190/52, 6x1-102/45, 6x1-40/39, 6-533TT, 2seaplanes (Walrus)</p>			

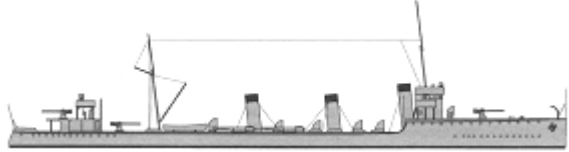
							
CL	La Argentina	1	1	La Argentina	1939		7500t, 164.9x17.2x5.0m, 4b,4gt, 54000hp, 30kts, 800p; 76belt, 51deck, 51turrets, 76CT; 3x3-152/50, 4x1-102/50, 6x2-25/70, 2x3-533TT, 2seaplanes (Walrus)

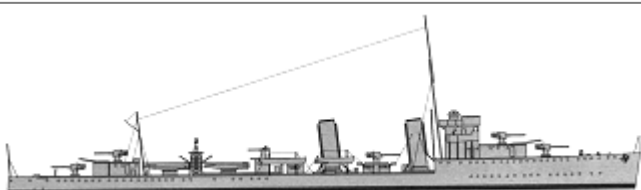
### TORPEDO SHIPS

DD	Catamarca	1	Catamarca	1912		1357t, 88.1x8.3x2.6m, 2b,2t, 24000hp, 32kts, 150p; 3x1-102/50, 2x1-40/39, 2x2-533TT, 1DCT
		2	Jujuy	1912		
	La Plata	3	Córdoba	1912		1368t, 90.0x9.0x2.8m, 5b,2t, 24000hp, 32kts, 150p; 3x1-102/50, 2x2-40/39, 2x2-533TT, 1DCT
		4	La Plata	1912		
	Cervantes	5	Cervantes	1927		2087t, 101.5x9.7x3.7m, 4b,2gt, 42000hp, 36kts, 175p; 5x1-120/45, 1x1-76/45, 2x3-533TT, 2DCR
		6	Juan de Garay	1927		
	Mendoza	7	Mendoza	1929		2120t, 102.1x9.7x3.8m, 4b,2gt, 42000hp, 36kts, 160p; 5x1-120/45, 1x1-76/45, 2x1-40/39, 2x3-533TT
		8	La Rioja	1929		
		9	Tucuman	1929		
	Buenos Aires	10	Buenos Aires	1938		2010t, 98.5x10.6x3.2m, 3b,2gt, 34000hp, 35.5kts, 130p; 4x1-120/45, 2x4-12.7, 2x4-533TT
		11	Entre Ríos	1938		
		12	Corrientes	1938		
		13	San Juan	1938		
		14	San Luis	1938		
		15	Misiones	1938		
		16	Santa Cruz	1938		



## SUBMARINES

SS	Santa Fé	3	1	Santa Fé	1933		935/1155t, 69.2x6.7x5.1m, 2d/em, 3000/1400hp, 17.5/9kts, 40p, 80m; 1x1-102/40, 8-533TT
			2	Santiago del Estero	1933		
			3	Salta	1933		

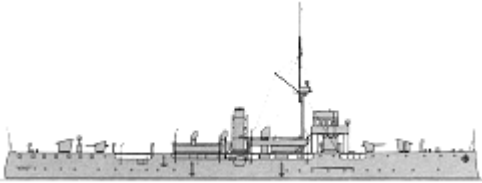
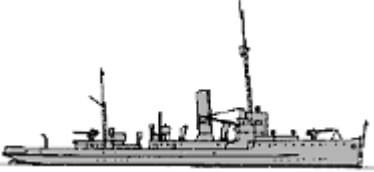
## OTHER FIGHTING SHIPS

PGR	Rosario	2	1	Rosario	1909		1055t, 76.4x9.8x2.1m, 2b,2vte, 1300hp, 14.5kts, 145p; 76belt, 25deck, 76CT; 2x1-152/13, 6x1-76/40, 2x1-40/39
			2	Paraná	1909		
DV	Cormoran	1	1	Cormoran	1918		553t, 58.2)x7.3x2.3m, 2b,2vte, 1850hp, 16.3kts, 40p; 3x1-75/55

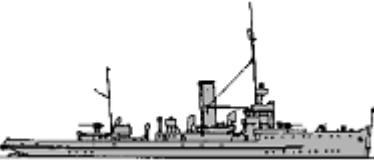
## MINE WARFARE SHIPS

M1	2	1	Bathurst	1916		513(1)-503(2)t, 58.3(1)-58.2(2)x7.3x2.3m, 2b,2vte, 1800(1)-1890(2)hp, 16.5kts, 40p; 3x1-75/55, 30m, MS
		2	Jorge	1916		
M5	3	3	Pinedo	1919		553(3)-548(4)-564(5)t, 59.3x7.4(2,3)-7.3(4)x2.2(3,4)-2.3(5)m, 2b,2vte, 1850hp, 16.3(3,4)-16(5)kts, 40p; 3x1-75/55, 30m, MS
		4	Seguí	1918		
		5	Thorne	1918		
MS	8	6	Drummond	1937		520t, 59.0x7.3x2.3m, 2d, 2000hp, 15kts, 62p; 2x1-102/50, 2x1-40/39, MS
		7	Robinson	1939		
		8	Granville	1937		
		9	Bouchard	1937		
		10	Py	1939		
		11	Parker	1938		
12	Seaver	1939				
13	Spiro	1938				

© Ivan Gogin, 2011-15



[home](#)

[World navies yesterday](#)

[1940](#)

# AUSTRALIA 01 January 1940

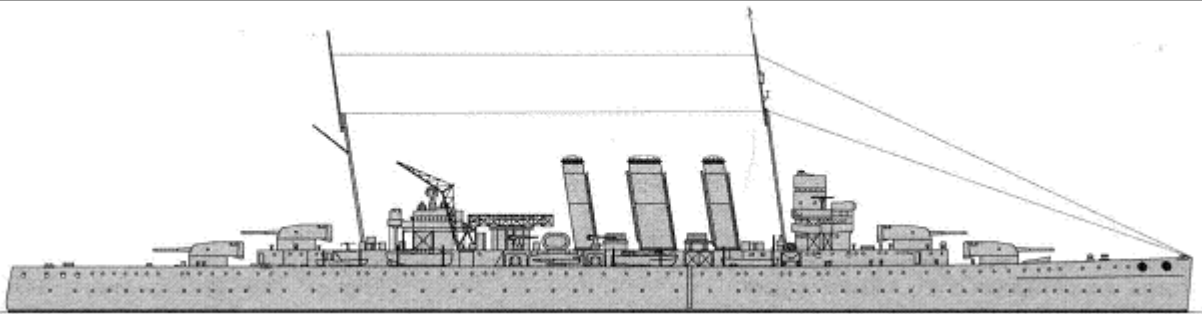
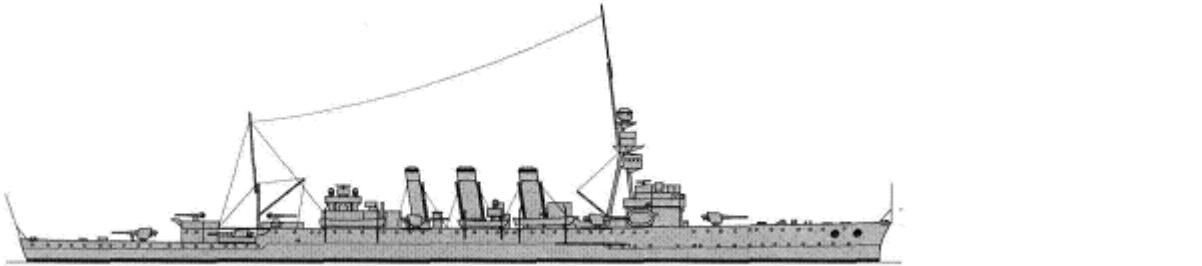
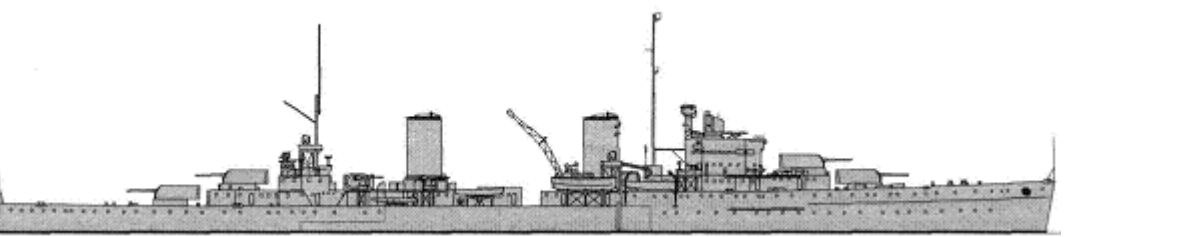

## CRUISERS

CA	Kent	1	Australia	1928		13400-13540t, 192.0-192.9x20.8x6.3m, 8b, 4gt, 80000hp, 31.5kts, 710p; 114(1)-25(2)mm belt, 111mm magazines, 38mm deck, 25mm turrets; 4x2-203/50, 4x1-102/45, (1x4+4x1)-40/39(1), 4x1-40/39(2), 2x4-12.7/62, 2x4-533TT, 1seaplane(2) (1 Walrus)
		2	Canberra	1928		
CL	Birmingham	1	Adelaide	1922		6160t, 141.0m, 10b, 2gt, 23500hp, 24.3kts, 480p; 51mm belt, 102mm shields, 38mm deck, 102mm CT; 8x1-152/45, 3x1-102/45, 4x1-47/40
		2	Sydney	1935		
	Amphion	3	Hobart	1936		8850-9150t, 171.4x17.3x5.6-5.8m, 4b, 4gt, 72000hp, 32.5kts, 570p; 76mm belt, 89mm magazines, 25mm turrets, 51mm deck; 4x2-152/50, 4x1-102/45(31), 4x2-102/45(32, 33), 3x4-12.7/62, 2x4-533TT, 1seaplane(2, 3) (1 Walrus + 1 Seagull(2); 2 Walrus(3))
		4	Perth	1936		
AMC	-	1	Manoora	1934		10856brt, 146.9x20.2x7.4m, 2d, 16kts; 7x1-152/45, 2x1-76/45

## TORPEDO SHIPS

V	1	1	Vampire	1917		1400t, 95.1x9.0x3.2m, 3b, 2gt, 27000hp, 34kts, 115p; 4x1-102/45, 2x1-40/39, 2x3-533TT, 1DCR
---	---	---	---------	------	--	---

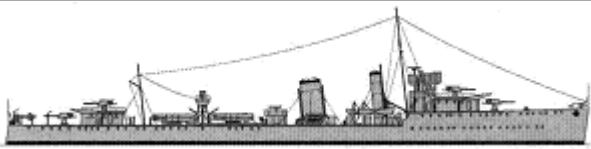

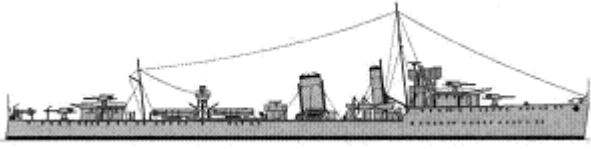
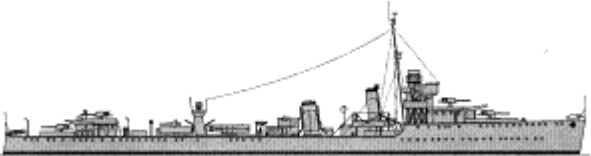
DL							
	Scott	1	2	Stuart	1918		2050t, 101.3x9.7x3.8m, 4b, 2gt, 40000hp, 36kts, 164p; 5x1-120/45, 1x1-76/45, 2x3-533TT, 2DCT, 1DCR
DD	V-Admiralty	1	1	Vendetta	1917		1523t, 95.1x9.0x3.2m, 3b, 2gt, 27000hp, 34kts, 134p; 4x1-102/45, 1x1-40/39, 2x3-533TT, 2DCT, 1DCR, MS
	W-Admiralty	2	3	Voyager Waterhen	1918 1918		1490t, 95.1x9.0x3.2m, 3b, 2gt, 27000hp, 34kts, 134p; 4x1-102/45, 1x1-40/39, 2x3-533TT, 2DCT, 1DCR, MS

## ESCORTS

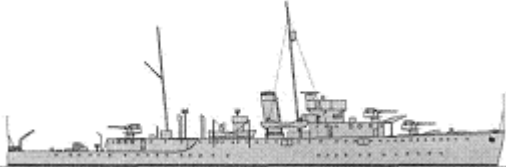
SL	Grimsby RAN	2	1	Yarra	1936		1510t, 81.2x11.0x3.1m, 2b, 2gt, 2000hp, 16.5kts, 100p; 3x1-102/45, 4x1-47/40, 2DCT, 1DCR
			2	Swan	1937		
APC	-	2	1	Bingera	1935		922brt
			2	St. Giles	1919		800brt
AY	-	1	1	Adele	1906		327t

## MINE WARFARE

AMS	-	7	1	Orara	1907	1297brt; 73.2x10.3xm, 1vte, 15kts
			2	Bermagui	1912	402t
			3	Coolebar	1911	479t
			4	Doomba	1919	750t; 1x1-102/45
			5	Medusa	1913	793t
			6	Tambar	1912	456t
			7	Warrawee	1909	423t
TL	Strath	1	1	Richard Bennett	1917	429t, 37.5x6.8x2.8m, 1b, 1vte, 430hp, 10kts, ?p; 1x1-76/40, 1DCT, MS
	-	6	2	Beryl II	1913	248t
			3	Goolwai	1919	271t
			4	Goorangai	1919	223t



		5	Korowa	1919		324t
		6	Olive Cam	1920		281t
		7	Tongkol	1926		292t

© Ivan Gogin, 2010-15

[home](#)[World navies yesterday](#)[1940](#)

## BELGIUM 01 January 1940

### TORPEDO SHIPS

TB	A1	1	1	West Diep	1915		137t, 41.6x4.6x1.2m, 1b,1vte, 1093hp, 19kts, 28p; 1x1-50/40, 2x1-450TT, 4m, MS
	A22	1	2	Wielingen	1917		250t, 50.0x5.3x2.1m, 1b,1gt, 3250hp, 25kts, 29p; 2x1-88/30, 1x1-450TT, MS

### ESCORTS

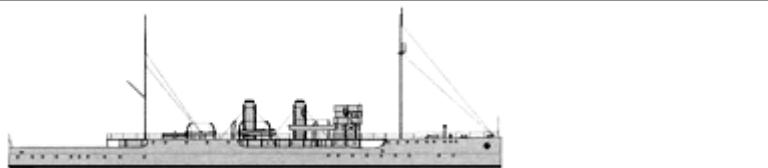
FPV	Flower	1	1	Zinnia	1915		1275t, 80.0x10.1x3.4m, 2b,1vte, 1400hp, 14kts, 90p
APV	-	7	1	P13	1939		451t
			2	P14	1939		451t
			3	P15	1939		451t
			4	P16	1939		451t
			5	T1	1939		134t
			6	T2	1939		134t
			7	Police de la Rade III	1909		122t

### MINE WARFARE SHIPS

TL	Mersey	1	1	A4	1917		665t, 45.1x7.2x2.7m, 1b,1vte, 600hp, 11kts; 1x1-47/40, MS
----	--------	---	---	----	------	--	---

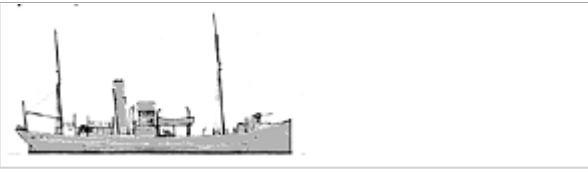
							
	Military	1	2	A6	1915	No picture	303t, 39.6x7.3x4.0m, 1b,1vte; 1x1-47/40, MS

© Ivan Gogin, 2010-15

[home](#)

[World navies yesterday](#)

[1940](#)

## Brazil 01 January 1940

### BATTLESHIPS

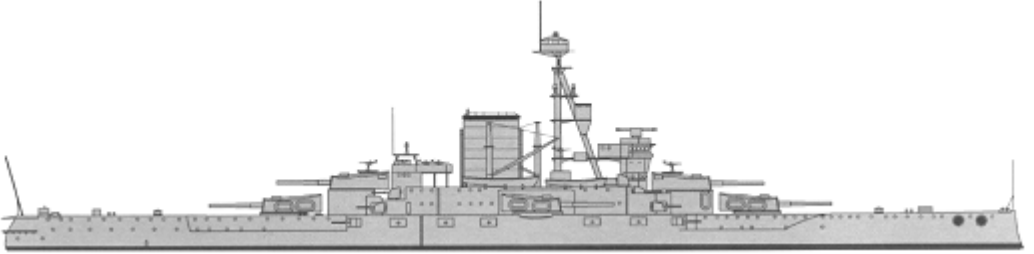
BB	Minas Gerais	2	1	Minas Gerais	1910		21200t, 165.5x25.33x7.6m, 6b(1)-18b(2),2vte, 30000(1)-23500(2)hp, 22(1)-21(2)kts, 900p; 229belt, 51deck, 229turrets, 305CT; 6x2-305/45, 14x1-120/50(1), 12x1-120/50(2), 4x1-102/45(1), 2x1-76/50, 4x1-40/39(1), 4x2-20/60(2)
			2	São Paulo	1910		

### CRUISERS

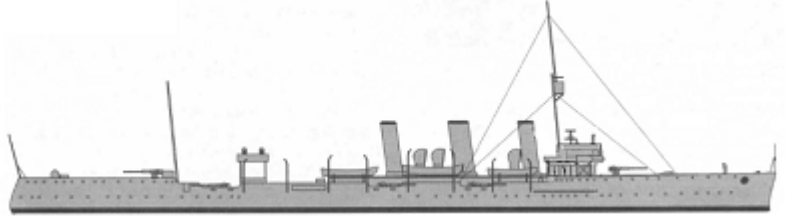
CL	Bahia	2	1	Bahia	1910		3185t, 122.4x11.9x4.4m, 6b,3gt, 22000hp, 28kts, 350p; 31slopes, 19deck, 76CT; 10x1-120/50, 4x1-76/40, 4x1-47/40, 2x2-533TT
			2	Rio Grande do Sul	1910		

### TORPEDO SHIPS

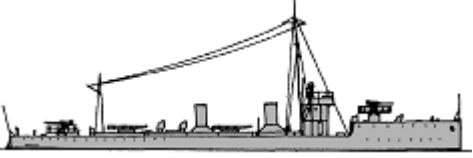

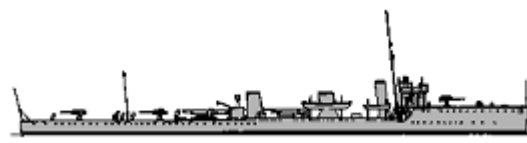
DD	Pará	6	1	Piauí	1909		560t, 73.2ppx7.2x2.4m, 2b,2vte, 8000hp, 27kts, 130p; 2x1-102/40, 4x1-47/40, 2x1-450TT
			2	Rio Grande do Norte	1909		
			3	Paraíba	1909		
			4	Sergipe	1910		
			5	Santa Catharina	1910		
			6	Mato Grosso	1909		
		Alexandrino Dealenca	1	7	Maranhão	1914	

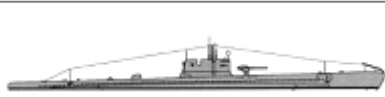

## SUBMARINES

SS	Humaytá	1	1	Humaytá	1929		1450/1884t, 86.7x7.8x4.3m, 2d/em, 4000/1000hp, 18.5/10kts, 61p, 100m; 1x1-120/41, 2x1-13.2, 6-533TT, 16m
	Tupy	3	2	Tupy	1937		674/853t, 60.2x6.5x3.7m, 2d/em, 1400/800hp, 14/7.5kts, 33p, 80m; 1x1-100/47, 2x2-13.2, 6-533TT
			3	Tymbira	1937		
			4	Tamoyo	1937		

## OTHER FIGHTING SHIPS

RMON	Pernambuco	1	1	Pernambuco	1910		470t, 44.5x7.3x1.6m, 2b,2vte, 800hp, 11kts, 60p; 168belt, 102deck, 152turret, 89CT; 1x2-120/45, 2x1-57/43, 2x1-37/32
	Parnaíba	1	2	Parnaíba	1938		720t, 55.0x10.2x1.5m, 2b,2vte, 1300hp, 12kts, 90p; 76belt, 38deck; 1x1-152/50, 2x1-47/40
APGR	-	3	1	Oyapock	1908		295t
			2	Mário Alves	1913		280t
			3	Amapá	1912		320t

## MINE WARFARE SHIPS

ML	Carioca	2	1	Carioca	1939		780t, 57.5ppx7.6x2.4m, 2b,2vte, 2200hp, 15kts, 70p; 1x1-102/45, 44m or MS
			2	Cananéia	1939		
AML	-	1	1	Itapimirim			340t; 30m
AMS	-	5	1	Heitor Perdigão	1921		500t
			2	Muniz Freire	1921		500t
			3	Itajai	1908		125t
			4	Itacurussa	1913		280t
			5	Iguape	1907		207t

© Ivan Gogin, 2011-15



[home](#)[World navies yesterday](#)[1940](#)

## Bulgaria 01 January 1940

### TORPEDO SHIPS

TB	Druzki	4	1	Druzki	1908		98t, 38.0x4.4x1.3m, 2b,1vte, 1950hp, 26kts, 32p; 2x1-37/83, 1x2-450TT, MS
			2	Smeli	1908		
			3	Khrabri	1908		
			4	Strogi	1909		

### COASTAL FORCES

PT	No1	1	1	No1	1939		63t, 28.0x4.5x1.5m, 3d, 1905hp, 33kts, 19p; 1x1-20/65, 2-533TT, 2DCR, 4m
PS	Belomorets	2	1, 2	Belomorets, Chernomorets	1917		87t, 33.5x4.5x1.7m, 3pe, 660hp, 18kts, 27p; 1x1-47/50
YP	Minyor	2	1, 2	Vzriv, Kapitan-Leytenant K. Minkov	1918		41t, 23.4x3.7x1.5m, 2pe, 440hp, 14kts, 16p; 1x1-37/83

© Ivan Gogin, 2011-15



[home](#)

[World navies yesterday](#)

[1940](#)

## BURMA 01 January 1940

### COASTAL FORCES



YP	Thornycroft	4	1 - 4	Pahlawan, Panglima, Panji, Peningat	1939	No picture	60t, 23.3x4.1x1.5m, (2d+1pe)(1,2)-3d(3,3), 780(1,2)-650(3,4)hp, 16(1,2)-14(3,4)kts; 1x1-47/40, MS
----	-------------	---	-------	-------------------------------------	------	------------	---

© Ivan Gogin, 2010-15

[home](#)[World navies yesterday](#)[1940](#)

## CANADA 01 January 1940

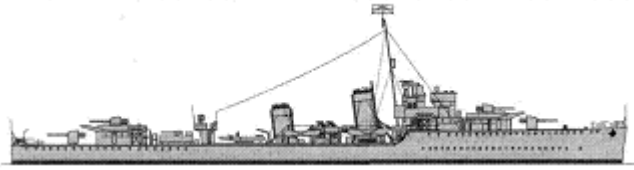
### TORPEDO SHIPS

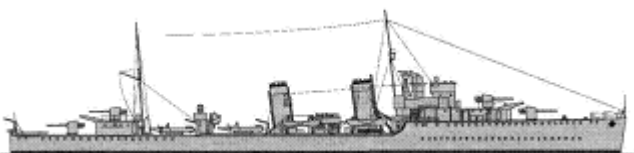

DL	C-leader	1	1	Assiniboine	1931		1942t, 100.3x10.1x3.8m, 3b, 2gt, 36000hp, 36kts, 175p; 4x1-120/45, 2x1-40/39, 2x4-533TT
DD	RCN A	2	1	Saguenay	1931		1747-1815t, 97.5x9.9x3.7m, 3b, 2gt, 32000hp, 35kts, 138p; 4x1-120/45, 2x1-40/39, 2x4-533TT, 3DCR, MS
			2	Skeena	1931		
C		4	3	Restigouche	1932		1865-1942t, 100.3x10.1x3.8m, 3b, 2gt, 36000hp, 36kts, 145p; 4x1-120/45, 2x1-40/39, 2x4-533TT, 3DCR, MS
			4	Fraser	1932		
			5	Ottawa	1932		
			6	St. Laurent	1932		

### ESCORTS

APC	-	3	1	French	1920	133brt
			2	Macdonald	?	210brt
			3	Nitinat	1939	135brt
AY	-	1	1	Sans Peur	1933	821t

### MINE WARFARE

Castle	1	1	TR39	1918		547t, 40.8x7.2x2.8m, 1b, 1vte, 480hp, 10.5kts, ?p; 1x1-76/40, MS
--------	---	---	------	------	--	--

TL	Ypres	3	2	Armentiers	1918	No picture	440t, ~42x7.1x4.1m, 1b, 1vte, ?hp, 10.5kts, ?p; 1x1-76/40, MS
			3	Arras	1918		
			4	Givenchy	1918		
	Basset	4	5	Comox	1938		725-775t, 48.9-50.0x8.3-8.4x3.2-3.4m, 1b, 1vte, 850-950hp, 12.5-13kts, 33p; 1x1-102/40, 2DCT, 2DCR, MS
			6	Fundy	1938		
			7	Gaspe	1938		
			8	Nootka	1938		
	-	3	9	Bras d`Or	1901		221t
			10	Venosta	1917		316t
			11	Viernoe	1914		273t
	DF	Admiralty wooden	1	1	Ebbtide	1917	

[home](#)[World navies yesterday](#)[1940](#)

## Chile 01 January 1940

### CAPITAL SHIPS

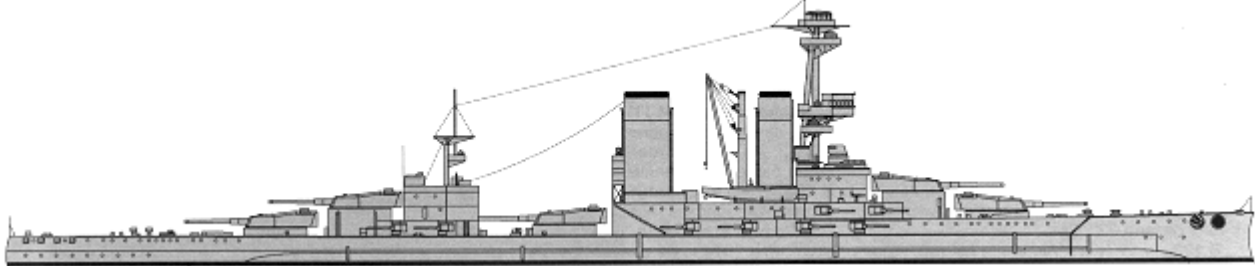
BB	Almirante Latorre	1	1	Almirante Latorre	1915		<p>32800t, 201.5x31.4x8.7m, 21b,4gt, 55000hp, 22.4kts, 1167p; 229belt, (25+37)deck, 254turrets, 279CT; 5x2-356/45, 14x1-152/50, 4x1-102/45, 2x1-40/39, 2x1-13.2, 4-533TT, 1seaplane(Ar95A)</p>
----	-------------------	---	---	-------------------	------	--	--

### CRUISERS

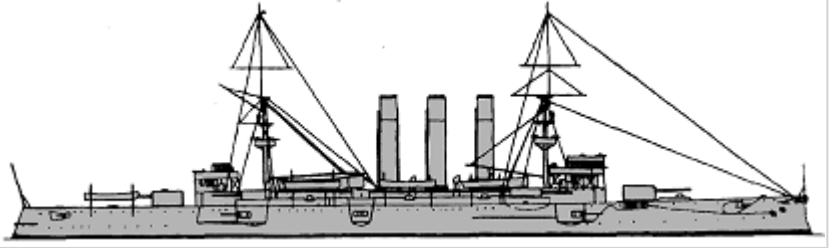
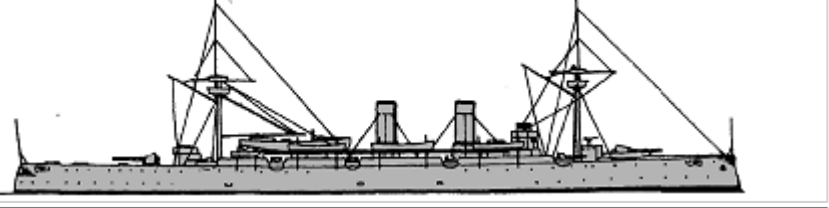

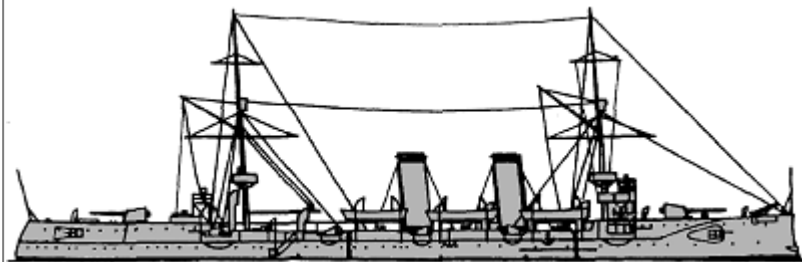
CA	O`Higgins	1	1	O`Higgins	1898		<p>8500t, 135.2x19.1x6.7m, 30b,2vte, 16000hp, 21kts, 500p; Harvey; 178belt, 51deck, 178turrets, 229CT; 4x1-203/40, 10x1-152/40, 13x1-76/40, 3-450TT</p>
	Blanco Encalada	1	1	Blanco Encalada	1894		<p>4568t, 112.8ppx14.2x5.6m, 8b,2vte, 14600hp, 22.8kts, 427p; Steel; 102slopes, 44deck, 152shields, 152CT; 2x1-203/40, 10x1-152/40, 5x1-76/40, 1x1-40/39</p>
CL	Chacabuco	1	2	Chacabuco	1902		<p>4877t, 127.5x14.2x5.2m, 8b,2vte, 15700hp, 23kts, 400p; Harvey; 114slopes, 44deck, 114shields, 76CT; 2x1-203/45, 10x1-120/40, 12x1-76/40, 6x1-47/40, 3-450TT</p>

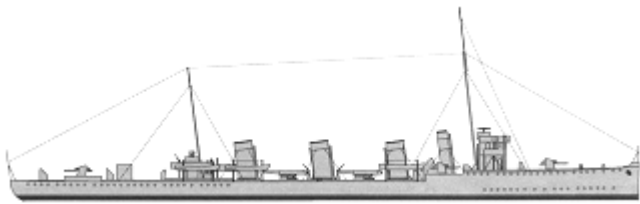
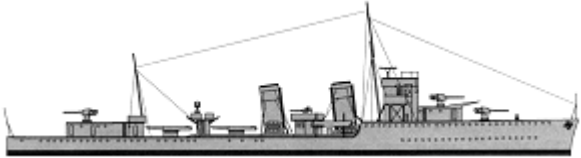

### TORPEDO SHIPS

DD	Almirante Lynch	1	Almirante Lynch	1913		1850t, 100.8x9.9x3.4m, 6b,3t, 30000hp, 31kts, 160p; 6x1-102/40, 2x2-533TT
		2	Almirante Condell	1914		
DD	Serrano	3	Sargeno Aldea	1929		1430t, 91.4x8.8x3.9m, 3b,2gt, 28000hp, 35kts, 130p; 3x1-120/45, 1x1-76/40, 2x3-533TT, 2DCT, 20m(4,5,7), MS(3,6,8)
		4	Ingeniero Hyatt	1929		
		5	Capitán Orella	1928		
		6	Guardiamarina Riquelme	1929		
		7	Teniente Serrano	1928		
		8	Cirujano Videla	1929		

### SUBMARINES

SS	H1	6	1	Gualcolda	1915		364/434t, 45.8x4.7x3.8m, 2d/em, 480/620hp, 13/11kts, 22p, 30m; 4-450TT
			2	Tegualda	1915		
			3	Rucumilla	1915		
			4	Quidora	1916		
			5	Fresia	1916		
			6	Guale	1916		
SS	Capitán O'Brien	3	7	Capitán O'Brien	1929		1540/2020t, 79.3x8.5x4.2m, 2d/em, 2750/1300hp, 15/9kts, 54p, 95m; 1x1-120/45, 8-533TT
			8	Almirante Simpson	1929		
			9	Capitán Thomson	1929		

### ESCORTS

PC	Yelcho	1	1	Yelcho	1908	No picture	467t, 39.0x7.0x2.9m, 1vte, 350hp, 12kts; 1x1-37/23
	Piloto Sibbald	1	2	Piloto Sibbald	1916	No picture	1100t, 43.1x8.7x3.4m, 2b,2vte, 1200hp, 11.5kts, 18p; 1x1-37/23

### MINE WARFARE SHIPS

ML	Elicura	3	1	Elicura	1920		545t, 52.6x7.5x3.4m, 3b,2vte, 1400hp, 14.5kts, 42p; 2x1-76/40, 50m
			2	Leucoton	1920		
			3	Orompello	1920		

© Ivan Gogin, 2012-15



[home](#)[World navies yesterday](#)[1940](#)

# China 01 January 1940

## ESCORTS

PC	Hai Ning	2	1	Wei Ning	1933		300t, 43.5x6.1x2.4m, 1b,1vte, 600hp, 10kts, 44p; 2x1-57/40 or 2x1-40/39
			2	Yi Ning	1934		

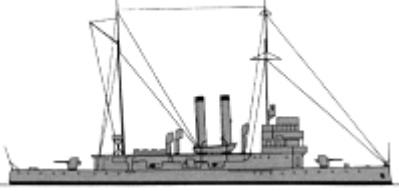
## OTHER FIGHTING SHIPS

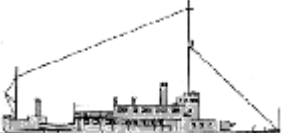
PG	Kiang Yuan	1	1	Kiang Yuan	1905		565t, 54.1x8.5x2.1m, 2b,2vte, 950hp, 13kts, 85p; 1x1-120/40, 1x1-76/40, 4x1-47/40
	Chu Tung	3	2	Chu Tung	1906		752t, 61.0x9.0x2.4m, 2b,2vte, 1350hp, 13kts, 117p; 2x1-120/40, 2x1-76/40
			3	Chu Tai	1906		
			4	Chu Kuan	1907		
	Yung Sui	1	5	Yung Sui	1929		800t, 68.0ppx9.1x1.8m, 2b,2vte, 4000hp, 18.5kts, 100p; 1x1-152/50, 1x1-120/45, 3x1-76/40, 4x1-57/40, 1x1-40/39
Ming Chuen	1	6	Ming Chuen	1930		500t, 61.8x7.9x1.8m, 2b,2vte, 2400hp, 16.6kts, 146p; 1x1-120/45, 1x1-102/45, 1x1-76/40, 2x1-57/40, 1x1-47/40	
PR	Chiang Hsi	2	1	Chiang Hsi	1912		140t, 43.9(1)-44.5(2)x7.5(1)-7.3(2)x0.6m, 2b,2vte, 450(1)-500(2)hp, 12kts, 49p; 1x1-37/32(1), 2x1-37/32(2)
			2	Chiang Kun	1912		

## COASTAL FORCES

PT	Shi 34	7	1-7	Chenggong, Tiangxiang, Chungmu, Wumu, Xiguan, Tingbi, Kefa	1936-1938		14t, 16.8x3.4x1.1m, 2pe, 1060hp, 45kts; 2-450TT
	Yue 22	2	8,9	Shichang, Gaoxing	1937		60t, 28.0x4.3x1.5m, 3pe, 3300hp, 33kts, 12p; 1x1-20/65, 2-533TT

© Ivan Gogin, 2011-15





[home](#)[World navies yesterday](#)[1940](#)

## Colombia 01 January 1940

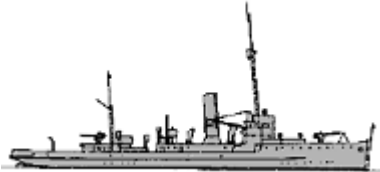
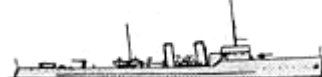
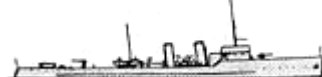

### TORPEDO SHIPS

DD	Antioquia	2	1	Antioquia	1934		1563t, 98.5x9.4x2.7m, 3b,2gt, 33000hp, 36kts, 147p; 4x1-120/50, 3x1-40/39, 2x4-533TT, 20m, 2DCT
			2	Caldas	1934		

### OTHER FIGHTING SHIPS

PG	Carabobo	3	1	Carabobo	1925	No picture	120t, 33.0x6.0x2.5m, 1b,1vte, 300hp, 13kts, 37p; 1x1-75/35, 1x1-37/50
			2	Boyaca	1925		
			3	Pichincha	1925		
PG	Bogota	1	4	Bogota	1919		630t, 59.6x7.3x2.2m, 2b,2vte, 1850hp, 16kts, 40p; 1x1-88/45, 2x1-75/35, 2x2-13.2
			1	Mariscal Sucre	1909		125t; 2x1-76/40
APG	-	1	1	Mariscal Sucre	1909		125t; 2x1-76/40
PGR	Cartagena	3	1	Cartagena	1931		142t, 41.8x7.2x0.8m, 2sd, 600hp, 15.5kts, 39p; 1x1-76/40
			2	Santa Marta	1931		
			3	Barranquilla	1931		
APGR	-	3	1	Presidente Mosquera	1912		230t; 1x1-76/40
			2	Demetrio Salamanca			120t
			3	Fernandez Madrid	1926		150t

### COASTAL FORCES

YPR	No1	4	1-4	No1-4	1913	No picture	20t, 24.0x3.8x1.2m, pe, 160hp, 12kts, 6p; 1x1-37/32
	A	1	5	A	1919		7t, 16.0x2.4x0.7m, 3pe, 780hp, 31.8kts, 7p
	B	2	6, 7	B, D	1918-1919		7t, 16.5x2.4x0.6m, 3pe, 680(6)-740(7)hp, 31.6kts, 7p
	C	1	8	C	1930	No picture	14t, 19.6x2.9x0.8m, 3pe, 1200hp, 34kts, 6p

© Ivan Gogin, 2011-15

[home](#)[World navies yesterday](#)[1940](#)

# Cuba 01 January 1940

## OTHER FIGHTING SHIPS

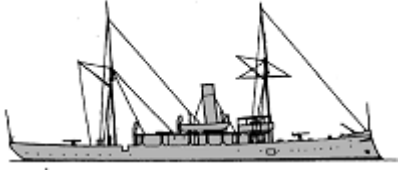
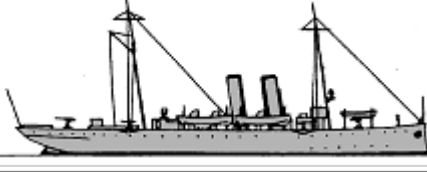
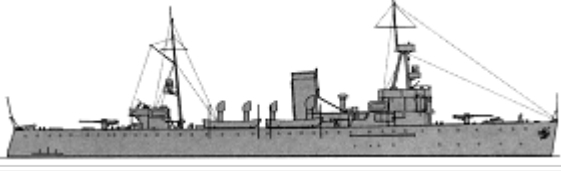
PG	Baire	1	1	Baire	1906		510t, 59.7x7.0x2.7m, 1vte, 1200hp, 14kts, 76p; 4x1-76/50, 2x1-37/40
	Santa Clara	1	2	Santa Clara	1911	No picture	52t, 32.0x1.8m, 12kts, 17p; 1x1-37/40
	Diez de Octubre	2	3	Diez de Octubre	1911	No picture	218t, 33.6x6.1x2.4m, 1vte, 12kts, 39p; 3x1-47/40
			4	Veinte y Cuatro de Febrero	1911		
	Patria	1	5	Patria	1911		1200t, 61.0ppx11.0x4.0m, 2vte, 4000hp, 16kts, 115p; 4x1-57/40, 4x1-47/40
	Cuba	1	6	Cuba	1911		2055t, 79.2x11.9x4.3m, 2vte, 6000hp, 18kts, 145p; 2x1-102/50, 2x1-76/50, 2x1-76/23, 6x1-57/40
	Habana	2	7,8	Habana, Pinar del Río	1912	No picture	80t, 30.5x5.5x1.3m, 1vte, 200hp, 12kts, 20p; 1x1-37/40
General Juan Bruno Zayas	1	9	General Juan Bruno Zayas	1914	No picture	300t, 50.0x3.4m, 11kts, 51p; 2x1-37/40	

## COASTAL FORCES

SC	CS1	4	1-4	CS1-4	1918		85t, 33.5x4.5x1.7m, 3pe, 660hp, 18kts, 27p; 1x1-76/23, 1DCT
----	-----	---	-----	-------	------	---	---

## COAST GUARD SHIPS

CGS	Veinte de Mayo	1	1	Veynte de Mayo	1895	No picture	203t, 45.7x5.6x3.2m, 500hp, 12kts, 43p; 2x1-47/40, 2x1-37/40
	Yara	1	2	Yara	1895	No picture	449t, 47.2x7.9x4.0m, 600hp, 12kts, 53p; 2x1-57/40, 2x1-47/40
	Matanzas	2	3,4	Matanzas, Las Villas	1912	No picture	80t, 30.5x5.5x1.3m, 1vte, 200hp, 12kts, 20p; 1x1-37/40
	Capitán Fernández Quevedo	1	5	Donativo	1932	No picture	130t, 30.8x5.5x2.1m, 2d, 300hp, 12kts, 21p; 2x1-37/40

© Ivan Gogin, 2012-15

[home](#)[World navies yesterday](#)[1940](#)

## DENMARK 01 January 1940

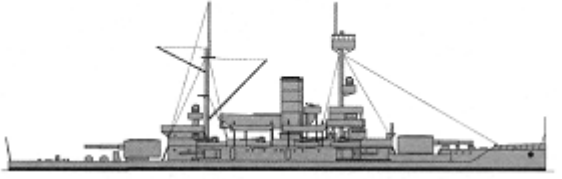
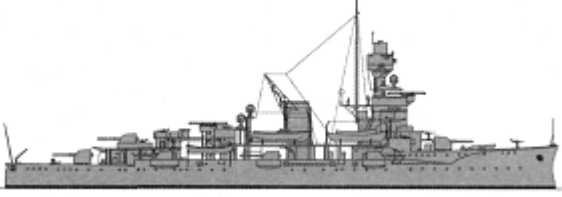

### CAPITAL SHIPS

BC	Herluf Trolle	1	1	Peder Skram	1908		3785t, 87.4x15.7x5.0m, 6b, 2vte, 5400hp, 16kts, 258p; 195belt, 65deck, 190turrets, 190CT; 2x1-240/43, 4x1-150/50, 8x1-75/55, 2x2-20/60, 4-450TT
	Niels Iuel	1	2	Niels Iuel	1923		4100t, 90.0x16.3x5.0m, 4b, 2vte, 5800hp, 16kts, 369p; 195belt, 55deck, 45shields, 170CT; 10x1-150/45, 2x1-57/55, 10x1-20/60, 2-450TT

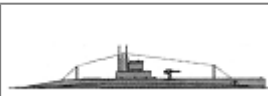

### TORPEDO SHIPS

TB	Springeren	4	1	Makrelen	1918		109t, 38.5x4.3x2.7m, 2b, 1vte, 2000hp, 24.6kts, 24p; 2x1-57/44, (1+1x1)-450TT
			2	Nordkaperen	1918		
			3	Havkatten	1920		
			4	Sælen	1920		
	Dragen	3	5	Dragen	1930		335t, 61.0x6.0x2.3m, 2b, 2gt, 6000hp, 27.5kts, 46p; 2x1-75/40, 2x1-20/60, (2+2x3)-450TT
			6	Hvalen	1931		
			7	Laxen	1931		
	Glenten	3	8	Glenten	1933		335t, 61.0x6.0x2.3m, 2b, 2gt, 6000hp, 27.5kts, 51p; 2x1-87/50, 2x1-20/60, (2+2x2)-450TT, 2DCT
			9	Høgen	1934		
			10	Ørnen	1935		

### SUBMARINES

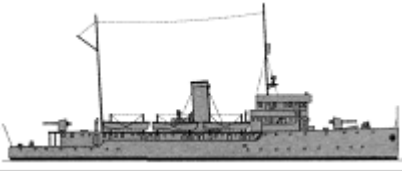
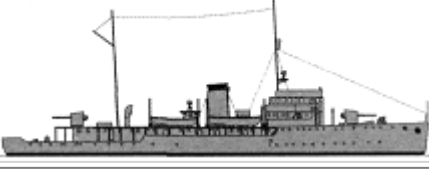
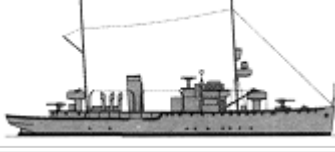

SS	Ægir	1	Ran	1915		185/235t, 40.6x3.7x2.4m, 2d/2em(1), 450/340hp, 13.5/9.8kts, 11p; 1x1-57/44, 3-450TT	
		2	Triton	1916			
		3	Galathea	1917			
	Rota	3	4	Rota	1920		301/369t, 47.5x4.8x2.7m, 2d/em, 900/640hp, 14.5/10.5kts, 17p; 1x1-57/44, 4-450TT
		5	Bellona	1921			
		6	Flora	1922			
	Daphne	2	7	Daphne	1926		308/381t, 49.0x5.2x2.5m, 2d/em, 900/400hp, 13.4/6.8kts, 24p; 1x1-75/35, 1x1-20/60, 6-450TT
		8	Dryaden	1927			
	Havmanden	3	9	Havmanden	1938		335/407t, 47.5x4.7x2.8m, 2d/em, 1200/450hp, 15.3/7.2kts, 25p; 2x1-40/56, 5-450TT
		10	Havfruen	1939			
		11	Havkalen	1939			

## ESCORTS

FPV	Beskytteren	1	1	Beskytteren	1900	No picture	415t, 43.4x7.6x3.8m, 2b, 1vte, 625hp, 11kts, 47p; 1x1-57/44, 2x1-47/44
	Islands Falk	1	2	Islands Falk	1906	No picture	760t, 56.0x8.9x5.2m, 2b, 1vte, 1100hp, 13kts, 63p; 2x1-75/55, 2x1-47/44
	Hvidbjørnen	1	3	Hvidbjørnen	1929		1050t, 63.2x9.7x5.2m, 1b, 1vte, 1800hp, 14.5kts, 58p; 2x1-87/50, 1seaplane (1 Nimrod)
	Maagen	1	4	Maagen	1932	No picture	110t, 21.8x5.4x2.9m, 1d, 120hp, 8kts, 11p; 1x1-37/23
	Ingolf	1	5	Ingolf	1934		1357t, 68.8x10.8x4.8m, 2b, 1vte, 2935hp, 16.2kts, 66p; 2x1-120/55, 2x1-57/44, 2x1-20/60, 1seaplane (1 Nimrod)
	Hejmdal	1	6	Hejmdal	1935		825t, 53.3x9.2x3.6m, 2b, 1vte, 800hp, 12.5kts, 49p; 2x1-75/55, 2x2-20/60
	Ternen	1	7	Ternen	1937	No picture	82t, 20.9x5.1x3.0m, 1d, 110hp, 8kts, 11p; 1x1-37/23
	Freja	1	8	Freja	1939		342t, 40.9x7.7x2.2m, 1b, 1vte, 255hp, 10.5kts, 40p; 2x1-75/55, 2x1-20/60
PC	Hvalrossen	1	1	Hvalrossen	1913		182t, 45.2x5.2x2.2m, 2b, 2vte, 3500hp, 26.3kts, 30p; 1x1-75/55, (1+1x2+1x1)-450TT

## MINE WARFARE

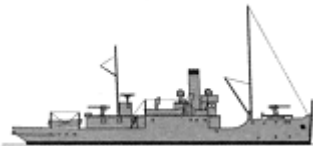
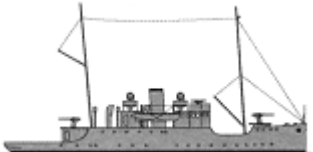
	Lossen	1	1	Lossen	1911		640t, 48.6x8.5x3.1m, 2b, 2vte, 900hp, 13kts, 53p; 2x1-75/55, 180mines

							
ML	Minekran Nr.V	2	2	Kvintus	1917	No picture	186t, 27.0x6.3x2.0m, 2dg, 2em, 290hp, 8kts, 26p; 2x1-37/38, 60mines
			3	Sixtus	1919		
	Henrik Gerner	1	4	Henrik Gerner	1928		463t, 49.0x6.2x2.4m, 2d, 900hp, 13.2kts, 45p; 2x1-75/55, 80mines
MS	Springeren	6	1	Springeren	1917		109t, 38.5x4.3x2.7m, 2b, 1vte, 2000hp, 24.6kts, 24p; 2x1-57/44, 1-450TT, MS
			2	Støren	1917		
			3	Søridderen	1917		
			4	Søhunden	1917		
			5	Havørnen	1917		
			6	Narhvalen	1917		
		Søløven	2	7	Søløven	1939	
	Søbjørnen	2	8	Søbjørnen	1939		

[home](#)

[World navies yesterday](#)

[1940](#)

## Dominican Republic 01 January 1940

### COASTAL FORCES

YP	GC1	6	1-6	GC1,3-7	1924-1926	No picture	37t, 22.9x4.2x1.2m, 1pe, 400hp, 13.5kts, 12p
	GC2	1	7	GC2	1918	No picture	18t, 13.7x3.4x1.1m, 2pe, 200hp, 9.5kts

© Ivan Gogin, 2012-15



[home](#)[World navies yesterday](#)[1940](#)

## Ecuador 01 January 1940

### OTHER FIGHTING SHIPS

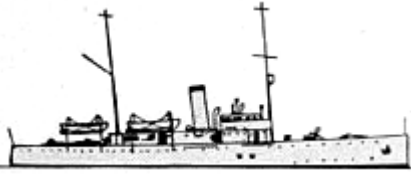
			1	Abdón Calderón	1884		300t; 2x1-76/40
APG	-	2	2	Presidente Alfaro	1917		869t; 2x1-76/50
DV	Atahualpa	1	1	Atahualpa	1927	No picture	100t, 1vte; 1x1-47/40

© Ivan Gogin, 2012-15

[home](#)[World navies yesterday](#)[1940](#)

## Egypt 01 January 1940

### ESCORTS

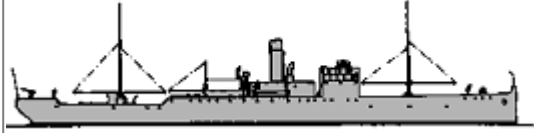
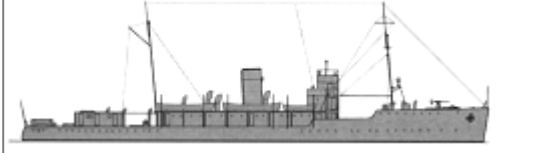
SL	Sollum	1	1	Sollum	1917		1493t, 80.0x10.7x3.5m, 2b,1vte, 2500hp, 17.5kts, 77p; 1x1-76/40
	El Amir Farouq	1	2	El Amir Farouq	1926		1441t, 75.3x10.4x4.0m, 2b,2vte, 2800hp, 17kts, 70p; 1x1-57/40
APC	-	1	1	Mabahiss	1930		618t

### OTHER FIGHTING SHIPS

PGR	Tamai	1	1	Hafir	1884/85	No picture	74t, sw; 1x1-76/40
-----	-------	---	---	-------	---------	------------	--------------------

### COASTAL FORCES

YP	Darfeel	2	1, 2	Darfeel, Noor El Bahr	1925	No picture	20t, 17.1xxm, 330hp, 17kts; 1x1-37/37
	Qamar	1	3	Qamar	1930s	No picture	23t, 21.6xxm, 11kts
	El Hoot	1	4	El Hoot	1930s	No picture	24t, 14.0xxm, 7kts
	Al Sarea	1	5	Al Sarea	1936	No picture	20t, 16.8x3.5x1.0m, 2pe, 900hp, 35kts, 9p; 1x1-37/37
	Raqib	1	6	Raqib	1938	No picture	20.1xxm, 2d, 540hp, 15kts; 1x1-37/37



[home](#)[World navies yesterday](#)[1940](#)

## Estonia 01 January 1940

### TORPEDO SHIPS

TB	Sulev	1	1	Sulev	1916		286t, 50.0x5.3x2.3m, 1b,1gt, 3250hp, 24kts, 35p; 2x1-75/50, 1x2-450TT, 10m
----	-------	---	---	-------	------	---	--

### SUBMARINES

SS	Kalev	2	1	Kalev	1937		665/853t, 59.5x7.2x3.5m, 2d/em, 1200/790hp, 13.5/8.5kts, 38p, 75m; 1x1-40/43, 4-533TT, 20m
			2	Lembit	1937		

### OTHER FIGHTING SHIPS

PG	Laine	1	1	Laine	1913		211t, 37.0x6.1x1.8m, 1b,1vte, 500hp, 12kts, 20p; 2x1-76/30
APGR	-	3	1	Ahti	1908		115t
			2	Tartu	1897		110t
			3	Wanemune	1914		200t; 2x1-75/50

### MINE WARFARE SHIPS

AML	-	2	1	Ristna	1906		600t; 175m
			2	Suurop	1906		600t; 175m

MSB	Kalev	1	1	Keri	1914		34t, 20.7x5.0x1.2m, 2sd, 60hp, 7.2kts, 8p; 25m, MS
	Olev	1	2	Vaindlo	1916		46t, 23.2x5.0x1.1m, 2sd, 60hp, 7.2kts, 8p; 40m, MS

© Ivan Gogin, 2011-15



[home](#)[World navies yesterday](#)[1940](#)

## Finland 01 January 1940

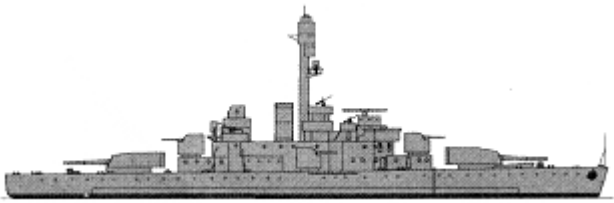
### CAPITAL SHIPS

BC	Väinämöinen	2	1	Väinämöinen	1932		~4200t, 95.0x16.9x4.5m, 4dg,2em, 6000hp, 15kts, 330p; 55belt, 20deck, 100turrets, 120CT; 2x2-254/45, 4x2-105/50, 4x1-40/39, 2x1-20/60
			2	Ilmarinen	1933		

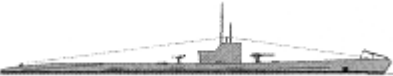
### SUBMARINES

SS	Vetehinen	3	1	Vetehinen	1930		600/716t, 63.5x6.1x3.5m, 2d/em, 1160/700hp, 13.5/8.5kts, 29p, 75m; 1x1-76/48, 1x1-20/60, 4-533TT, 20m
			2	Vesihiiisi	1930		
			3	Iku-Turso	1931		
	Saukko	1	4	Saukko	1930		130/140t, 32.4x4.1x2.9m, 1d/em, 200/120hp, 7/5.7kts, 15p, 75m; 1x1-12.7, 2-450TT, 6m
	Vesikko	1	5	Vesikko	1934		254/303t, 40.9x4.1x3.8m, 2d/em, 700/360hp, 13.1/8.1kts, 19p, 90m; 1x1-20/60, 5-450TT

### ESCORTS



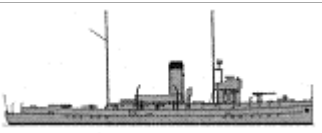
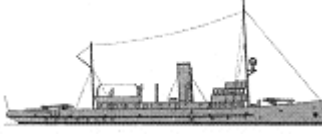

APC	-	6	1	Tursas	1933	360t; 1x1-75/50
			2	Uisko	1933	219t; 1x1-75/50
			3	Aura I		550t
			4	Aura II	1884	134t; 1x1-75/50
			5	Suursaari		219t
			6	Turku		224t

### OTHER FIGHTING SHIPS





--	--	--	--	--	--	--

PG	Karjala	2	1	Karjala	1918		342t, 50.1x6.8x2.3m, 2b,2vte, 1150hp, 15kts, 48p; 2x1-75/50, 1x1-40/39, 30m
			2	Turunmaa	1918		
	Hämeenmaa	2	3	Hämeenmaa	1918		
			4	Uusimaa	1918		

## COASTAL FORCES

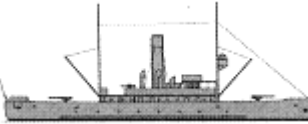
PT	MTV1	2	1, 2	Sisu, Hurja	1918		13t, 16.4x2.8x1.4m, 2pe/em, 500/10hp, 26.5kts, 8p; 2-450TT
	MTV3	1	3	Isku	1926		11t, 16.6x3.4x1.1m, 2pe, 600hp, 31kts, 5p; 2-450TT
	MTV4	4	4-7	Syöksy, Nuoli, Vinha, Raju	1928-1929		12t, 16.8x3.4x1.0m, 2pe/1pe(2), 750/25hp, 40kts, 7p; 2-450TT
YP	VMV1	2	1, 2	VMV1, 2	1930	No picture	30t, 23.5x4.2x1.0m, 2pe/1pe(2), 1120/100hp, 25kts, 8p; 1x1-20/60
	VMV5	2	3, 4	VMV5, 6	1931	No picture	30t, 24.6x4.4x1.1m, 2pe/1pe(2), 900/140hp, 24.6kts, 8p; 1x1-20/60
	VMV8	10	5-14	VMV8-17	1935		31t, 25.6x4.4x1.0m, 2sd/1sd(2), 1120/180hp, 23.8kts, 8p; 1x1-20/65

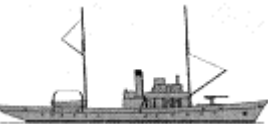
## MINE WARFARE SHIPS AND CRAFTS

ML	M1	1	1	Louhi	1916		776t, 50.0x8.0x2.7m, 3b,1vte, 800hp, 12kts, 46p; 2x1-75/50, 2x1-40/39, 1x1-20/60, 150m
AML	-	4	1	Baltic	1897		1096t, 61.4x10.0xm, 1vte, 10.5kts; 1x1-75/50, 60m
			2	Frei	1900		561t; 1x1-75/50, 50m
			3	Poseidon	1899		804t; 1x1-75/50, 60m
			4	Suomi	1910		659t; 1x1-75/50, 60m
MLB	T15	3	1-3	Paukku, Lieska, Loimu	1914		60t, 20.7x5.0x1.2m, 2sd, 60hp, 7.2kts, 8p; 1x1-20/60, 30m
	T17	2	4, 5	Miina, Pommi	1916		80t, 23.2x5.0x1.1m, 2sd, 60hp, 7.2kts, 8p; 1x1-20/60, 45m
MS	T1	2	1	Rautu	1918		220t, 43.6x6.1x1.7m, 2b,2vte, 400hp, 11kts, 35p; 1x1-75/50, 1x1-20/60, MS, 30m
			2	Vilppula	1917		
MSB	A8	16	1-16	A11, 12, 19-21, 37-45, MP1, 5	1916 - 1917	No picture	20t, 19.8x3.6x1.2m, 1pe, 10kts; MS
	AF1	1	17	AF2	1917/18		25t, 15.3x3.5xm, 1pe, 50hp, 9kts, 8p; MS
	BVA	4	18-21	BVA, BVB, BVC, BVD	1910		25t, 22.2x3.1x0.5m, 2pe, 200hp, 14.5kts, 12p; 8belt, 8deck, 8CT; 1x1-76/16, MS
	Ahven	6	22-27	Ahven, Kiiski, Muikku, Särki, Lahna, Kuore	1936-1937	No picture	17t, 17.2x3.8x1.3m, 1d, 65hp, 10kts, 8p; 1x1-20/60, MS
	SM1	2	28, 29	SM1, 2	1939	No picture	20t, 18.0x3.8x1.7m, 1pe, 80hp, 9kts; 1x1-20/60, MS

## COAST GUARD

CGB	SP1	1	1	SP1	1935	No picture	21t, 21.9xxm, 11kts
-----	-----	---	---	-----	------	------------	---------------------

© Ivan Gogin, 2011-15



[home](#)[World navies yesterday](#)[1940](#)

## France 01 January 1940

*IN SERVICE: 7 battleships, 1 fleet aircraft carrier, 1 seaplane tender, 7 heavy cruisers, 10 light cruisers, 1 training cruiser, 12 auxiliary cruisers, 58 destroyers, 13 torpedo boats, 77 submarines, 9 sloops, 15 auxiliary sloops, 32 fast anti-submarine ships (corvettes), 11 submarine chasers, 35 patrol trawlers and tugs, 28 auxiliary patrol vessels, 9 river gunboats, 1 armed survey vessel, 7 motor torpedo boats, 5 auxiliary patrol launches, 4 auxiliary minelayers, 1 netlayer, 9 minesweepers, 252 auxiliary minesweepers*

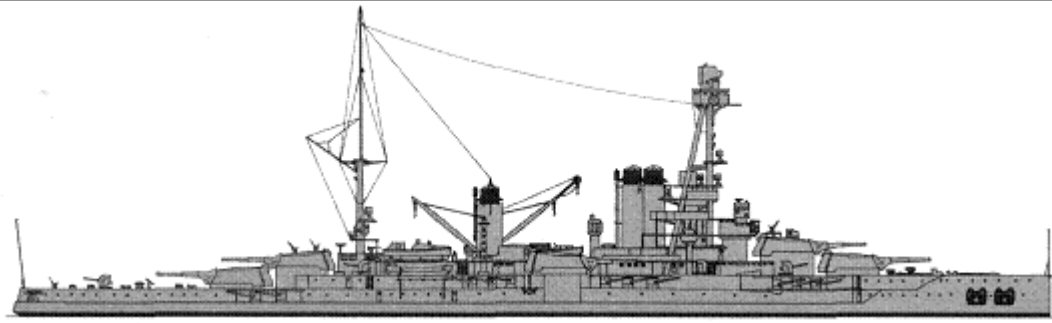
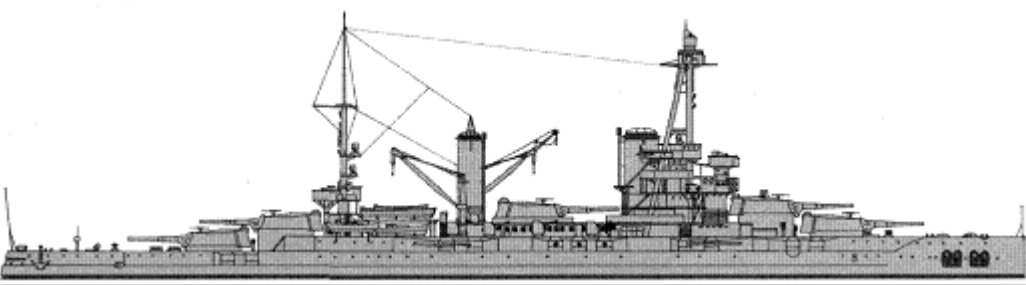
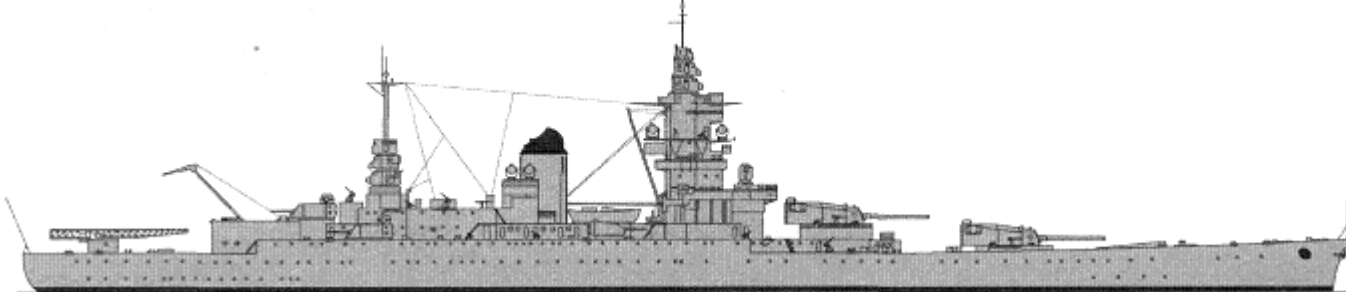

### CAPITAL SHIPS

	Courbet	1	Courbet	1913		26000t, 168.0x27.9x9.0m, 26b,4gt(1)-4t(2), 28000hp, 20kts, 1108p; 270belt, (70+40)deck, 320turrets, 300CT; 6x2-305/45, 22x1-139/55, 6x1-75/50(1), 7x1-75/50(2), (6x2+2x1)-13.2
		2	Paris	1914		
BB	Bretagne	3	Bretagne	1915		25000t, 166.0x26.9x9.8m, 6b,4gt, 43000hp, 21.4kts, 1133p; 250belt, (45+40)deck, 400-250turrets, 300CT; 5x2-340/45(3,4), 4x2-340/45(5), 14x1-139/55, 4x2-100/45(5), 8x1-75/50(3,4), 4x1-37/50, 2x4-13.2, 4seaplanes (Loire 130(5))
		4	Provence	1915		
		5	Lorraine	1916		
	Dunkerque	6	Dunkerque	1937		34884(6)-36380(7)t, 215.1(6)-215.5(7)x31.1x9.6(6)-9.8(7)m, 6b,4gt, 110960(6)-112000(7)hp, 29.5kts, 1431p; 225(6)-283(7)belt, (130+40)deck, 330(6)-360(7)turrets, 270CT; 2x4-330/52, (3x4+2x2)-130/45, 5x2-37/50(6), 4x2-37/50(7), 8x4-13.2(6), 6x4-13.2(7), 3seaplanes (Loire 130)
		7	Strasbourg	1939		

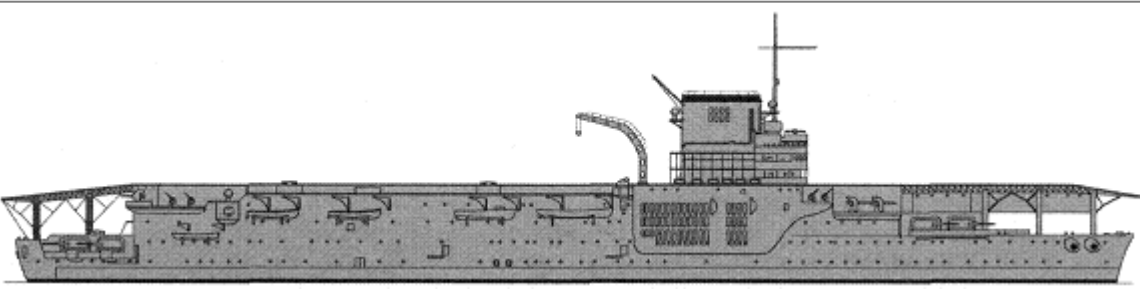
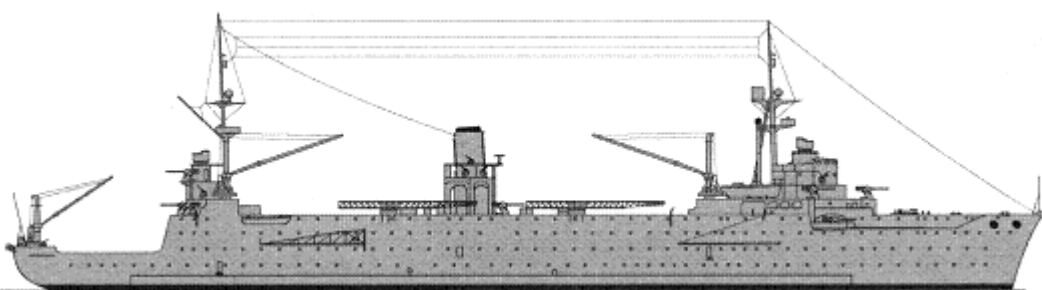
## AIRCRAFT CARRYING SHIPS

CV	Béarn	1	1	Béarn	1927		28400t, 182.6x31.0x9.3m, 6b,2t,2vte(4), 37500hp, 21.5kts, 865p; 80belt, (24+24+60)deck, 70casemates; 8x1-155/50, 6x1-75/50, 8x1-37/50, 4-550TT, 40aircraft (20 D.373, 5 V.156F)
AV	Commandant Teste	1	1	Commandant Teste	1932		11500t, 167.0x27.0x6.9m, 4b,2gt, 21000hp, 20.5kts, 644p; 50belt, 36deck, 80CT; 12x1-100/45, 8x1-37/50, 6x2-13.2, 26seaplanes (14 Loire 130, 12 Laté 298)

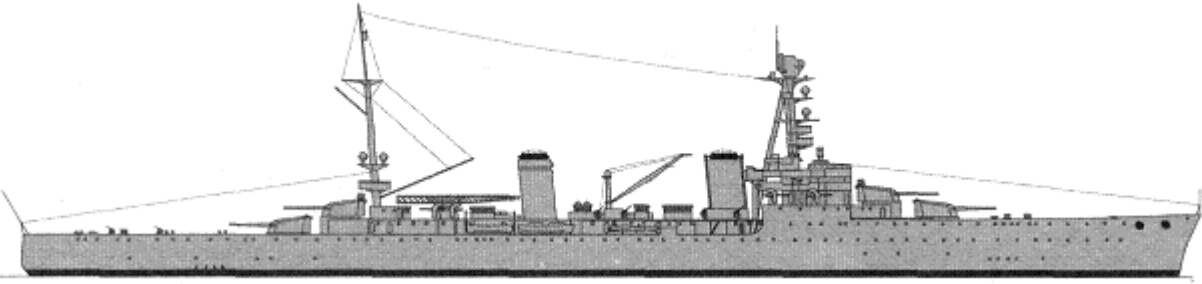
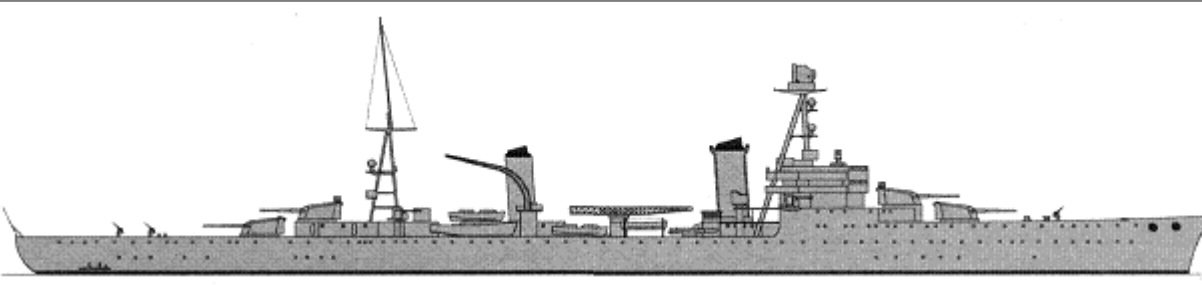
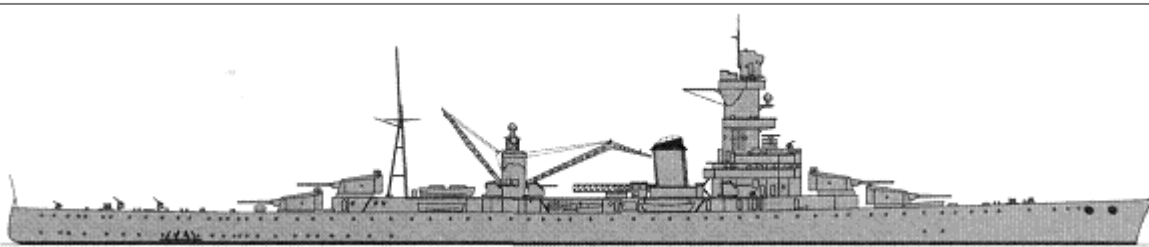
## CRUISERS

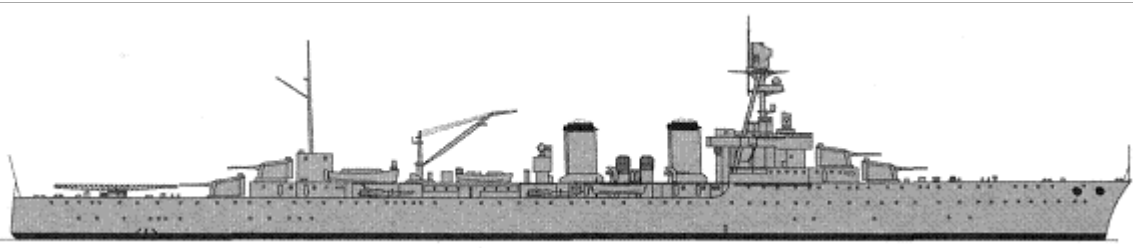
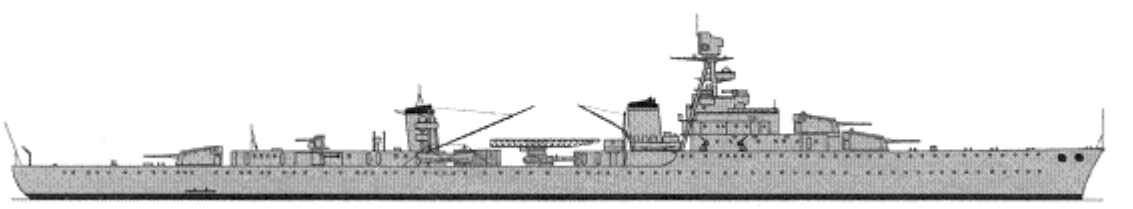
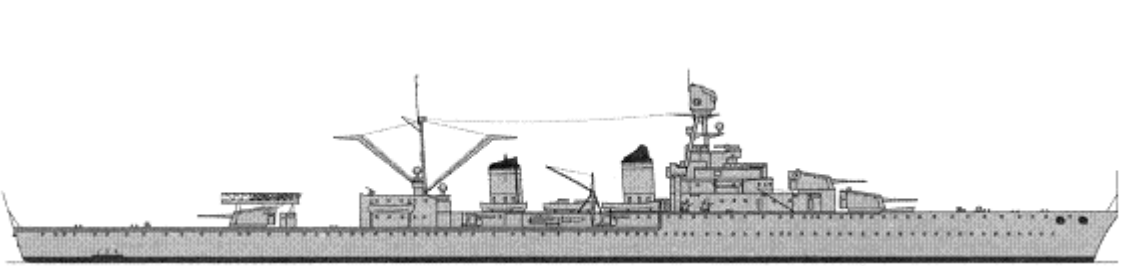
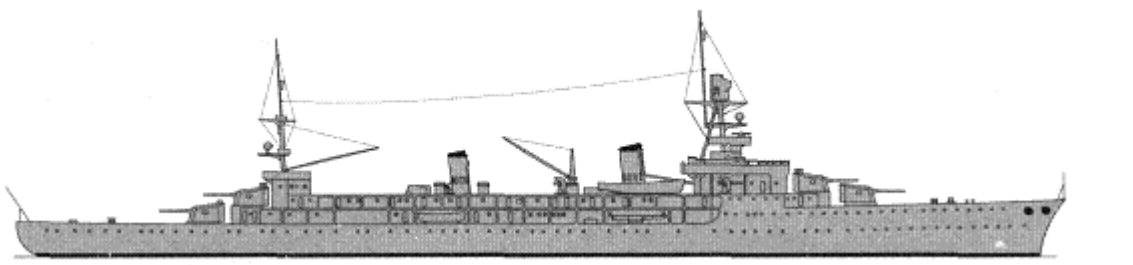

	Duquesne	2	1	Duquesne	1927		12200t, 191.0x19.0x6.3m, 9b,4gt, 120000hp, 33.7kts, 605p; 30magazines, 24deck, 30turrets, 30CT; 4x2-203/50, 8x1-75/50, 8x1-37/50, 6x2-13.2, 2x3-550TT, 1seaplane (CAMS.37)
			2	Tourville	1928		
CA	Suffren	4	3	Suffren	1930		12928(3)-13103(4)-13429(5)-13407(6)t, 196.0(3)-194.2(4,5)-194.0(6) x20.0(3)-19.4(4)-19.3(5,6) x7.3(3,4)-7.5(5)-7.2(6)m, 8b(3,4)-6b(5,6),3gt, 90000hp, 32kts, 605p; 50belt(3,4)-54(5)-60(6)torpedo bulkhead, (25+18)(3)-(22+18)(4)-(22+30)(5,6)deck, 30turrets, 30CT; 4x2-203/50, 8x1-90/50(4,5), 4x2-90/50(6), 8x1-75/50(3), 8x1-37/50(3), 6x1-37/50(4-6), 3x4-13.2(3-5), 4x4-13.2(6), 2x3-550TT, 2seaplanes (GL.810(3)), 3seaplanes (GL.810(4-6))
			4	Colbert	1931		
			5	Foch	1931		
			6	Dupleix	1932		
	Algérie	1	7	Algérie	1934		13461t, 186.2x20.0x6.2m, 6b,4gt, 84000hp, 31kts, 616p; 110belt, 80deck, 100turrets, 100CT; 4x2-203/55, 6x2-100/45, 4x1-37/50, 4x4-13.2, 2x3-550TT, 3seaplanes (GL.812)
			1	Duguay Trouin	1926		9350t, 181.6x17.2x5.2m, 8b,4gt, 100000hp, 33kts, 578p;
				Lamotte-			

CL	Duguay Trouin	3	2	Picquet	1926		20magazines, 20deck, 25turrets, 25CT; 4x2-155/50, 4x1-75/50, 2x1-25/60(3), 6x2-13.2(1,2), 4x4-13.2(3), 4x3-550TT, 2seaplanes (GL.810)
			3	Primaguet	1926		
	Émile Bertin	1	4	Émile Bertin	1935		8480t, 177.0x16.0x6.6m, 6b,4gt, 102000hp, 34kts, 567p; 30magazines, 20deck, 25CT; 3x3-152/55, (1x2+2x1)-90/50, 4x2-37/50, 4x2-13.2, 2x3-550TT, 2seaplanes (GL.832), 200m
	La Galissonnière	6	5	La Galissonnière	1936		9100t, 179.5x17.5x5.4m, 4b,2gt, 84000hp, 31kts, 540p; 105belt, 38deck, 100turrets, 95CT; 3x3-152/55, 4x2-90/50, 4x2-13.2, 2x2-550TT, 4seaplanes (GL.832(5)), 3seaplanes (Loire 130(6-10))
			6	Jean de Vienne	1937		
			7	Marseillaise	1937		
8			Gloire	1937			
9			Montcalm	1937			
10	Georges Leygues	1937					
CT	Jeanne d'Arc	1	1	Jeanne d'Arc	1931		8950t, 170.0x17.7x6.4m, 4b,2gt, 32500hp, 25kts, 506p+176; 20magazines, 25turrets, 25CT; 4x2-155/50, 4x1-75/50, 2x1-37/50, 4x2-13.2, 2x1-550TT, 2seaplanes (CAMS.37)
AMC -		12	1	Aramis	1932		17537brt, 165.4x21.2x8.7m, 2d, 14700hp, 17kts; 8x1-139/45, 2x1-75/35, 2x1-37/50
			2	Koutoubia	1931		8790brt, 135.2x17.8x7.3m, 2t, 8800hp, 16.5kts; 8x1-139/45, 1x1-37/50, 2x1-25/60
			3	Ville d'Oran	1936		10172brt, 140.8x19.3x6.6m, 2gt, 18000hp, 21kts; 5x1-139/45
			4	El Mansour	1933		5818brt, 121.7x16.4x5.5m, 2gt, 12000hp, 21.5kts; 7x1-139/45, 2x1-75/35
			5	Victor Schoelcher	1939		4504brt, 114.5x15.8x5.9m, 2d, 5200hp, 17kts; 7x1-139/45, 2x1-75/35, 2x1-37/50
			6	Colombie	1931		13390brt, 155.2x20.4x8.0m, 2t, 7400hp, 16kts; 7x1-149/45, 2x1-75/35, 2x1-37/50, 2DCR
			7	Charles Plumier	1939		4504brt, 114.5x15.8x5.9m, 2d, 5200hp, 17kts; 7x1-149/45, 2x1-75/35, 2x1-37/50
			8	El Djézair	1934		5818brt, 121.5x16.4x5.5m, 2gt, 12000hp, 21.5kts; 7x1-139/45, 2x1-75/35
			9	El Kantara	1932		5079brt, 116.3x16.4x5.7m, 2gt, 8000hp, 20.5kts; 7x1-

					139/45, 2x1-75/35
	10	Barfleur	1938		3259brt, 102.6x13.9x5.8m, 1d, 3850hp, 16kts; 7x1-149/45, 2x1-75/35, 2x1-37/50
	11	Quercy	1937		3100brt, 98.5x13.9x5.7m, 1d, 3750hp, 15.5kts; 7x1-139/45, 2x1-75/35, 2x1-37/50
	12	Estérel	1938		3100brt, 98.5x13.9x5.7m, 1d, 3750hp, 15.5kts; 7x1-139/45, 2x1-75/35, 2x1-37/50

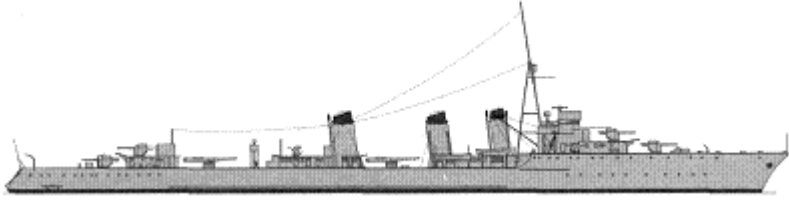
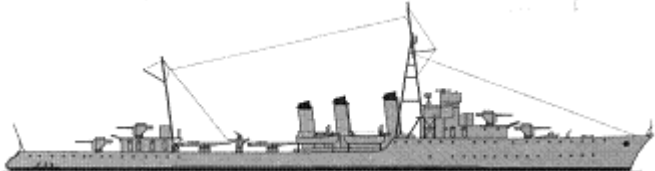
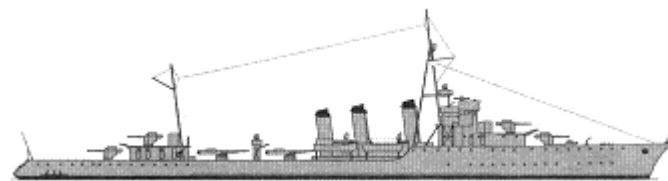

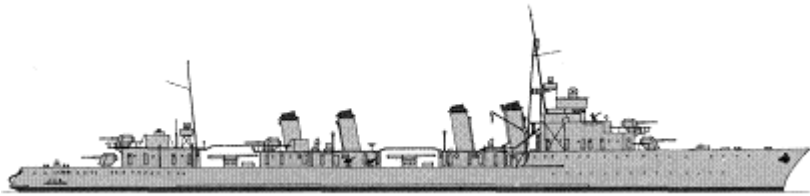
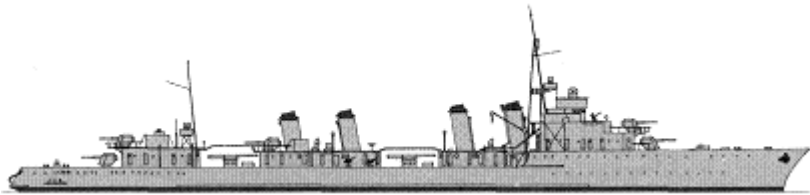
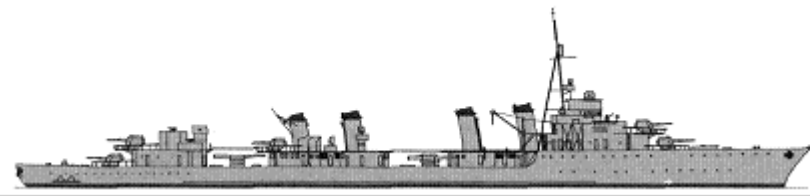
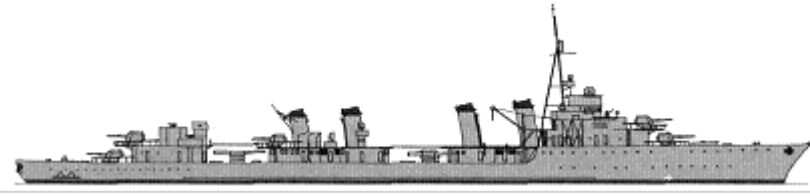
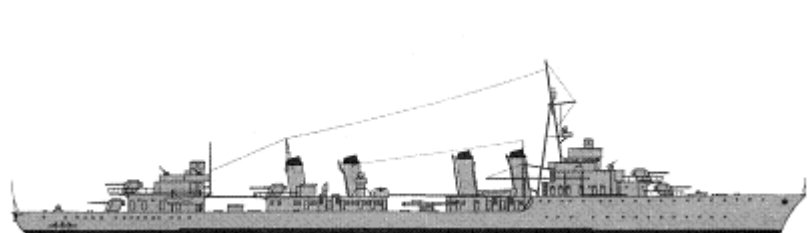
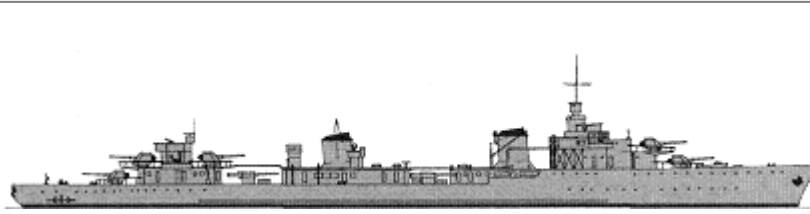
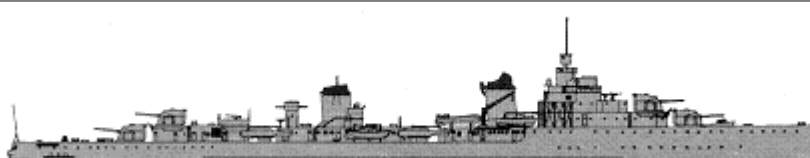

## TORPEDO SHIPS



Chacal	6	1	Tigre	1925		3050t, 126.8x11.3x4.1m, 5b,2gt, 50000hp, 35.5kts, 195p; 4x1-130/40, 4x2-13.2, 2x3-550TT, 4DCT, 2DCR
		2	Jaguar	1926		
		3	Chacal	1926		
		4	Panthère	1926		
		5	Lynx	1927		
		6	Léopard	1927		
Bourrasque	12	7	Simoun	1926		1900t, 105.8x9.6x4.3m, 3b,2gt, 33000hp, 33kts, 142p; 4x1-130/40, 2x1-37/50, 2x2-13.2, 2x3-550TT, 2DCT, 2DCR
		8	Orage	1926		
		9	Tempête	1926		
		10	Bourrasque	1926		
		11	Tramontane	1927		
		12	Ouragan	1927		
		13	Mistral	1927		
		14	Siroco	1927		
		15	Trombe	1927		
		16	Typhon	1928		
		17	Cyclone	1928		
		18	Tornade	1928		
L'Adroit	14	19	La Palme	1928		2000t, 107.2x9.8x4.3m, 3b,2gt, 34000hp, 33kts, 142p; 4x1-130/40, 2x1-37/50, 2x2-13.2, 2x3-550TT, 2DCT, 2DCR
		20	Le Mars	1928		
		21	La Railleuse	1928		
		22	Le Fortune	1928		
		23	Brestois	1928		
		24	Boulonnais	1928		
		25	L'Alcyon	1929		
		26	L'Adroit	1929		
		27	Le Bordelais	1930		
		28	Forbin	1930		
		29	Fougueux	1930		
		30	Le Foudroyant	1930		
		31	Basque	1931		
		32	Frondeur	1931		

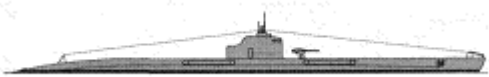

DD	Guépard	2	33	Guépard	1929		3200t, 130.2x11.8x4.7m, 4b,2gt, 64000hp, 35.5kts, 230p; 5x1-139/40, 4x1-37/50, 2x2-13.2, 2x3-550TT, 2DCR
			34	Bison	1930		
Valmy	4	35	Valmy	1930		3200t, 130.2x11.8x4.7m, 4b,2gt, 64000hp, 35.5kts, 230p; 5x1-139/40, 4x1-37/50, 2x2-13.2, 2x3-550TT, 2DCR	
		36	Verdun	1930			
		37	Lion	1931			
		38	Vauban	1931			
Aigle	4	39	Aigle	1932		3410t, 128.5x11.8x5.0m, 4b,2gt, 64000hp, 36kts, 230p; 5x1-139/40, 4x1-37/50, 2x2-13.2, 2x3-550TT, 4DCT, 2DCR	
		40	Gerfaut	1932			
		41	Albatros	1932			
		42	Vautour	1932			
Épervier	2	43	Épervier	1934		3410t, 129.3x11.8x5.0m, 4b,2gt, 68000hp, 36kts, 230p; 5x1-139/40, 4x1-37/50, 2x2-13.2, (1x3+2x2)-500TT, 4DCT, 2DCR, 20m	
		44	Milan	1934			
Vauquelin	6	45	Cassard	1933		3140t, 129.3x11.8x5.0m, 4b,2gt, 64000hp, 36kts, 230p; 5x1-139/40, 4x1-37/50, 2x2-13.2, (1x3+2x2)-500TT, 4DCT, 2DCR, 50m	
		46	Tartu	1933			
		47	Vauquelin	1934			
		48	Maillé Brézé	1934			
		49	Kersaint	1934			
		50	Chevalier Paul	1934			
Le Fantasque	6	51	Le Terrible	1935		3380t, 132.4x12.5x5.0m, 4b,2gt, 74000hp, 37kts, 210p; 5x1-139/50, 2x2-37/50, 2x2-13.2, 3x3-500TT, 2DCR, 50m	
		52	L'Audacieux	1935			
		53	Le Malin	1936			
		54	L'Indomptable	1936			
		55	Le Fantasque	1936			
		56	Le Triomphant	1936			
Mogador	2	57	Mogador	1938		4018t, 137.5x12.7x4.6m, 4b,2gt, 92000hp, 39kts, 264p; 4x2-139/50, 2x2-37/50, 2x2-13.2, (2x3+2x2)-500TT, 2DCT, 40m	
		58	Volta	1939			
No295	1	1	No369	1908		101t, 38.0x4.4x1.9m, 2b,1vte, 2000hp, 26kts, 23p; 1x1-75/35, 2x5-37/20, 1-450TT	
		2	La Melpomène	1936			
		3	La Pomone	1936			

TB	La Melpomène	12	4	La Flore	1936		<p>895t, 80.7x8.0x3.1m, 2b,2gt, 22000hp, 34.5kts, 105p; 2x1-100/45, 2x2-13.2, 1x2-550TT, 1DCT, 1 Ginocchio TAST</p>
			5	L`Iphigénie	1936		
			6	Bombarde	1937		
			7	La Poursuivante	1937		
			8	La Cordelière	1937		
			9	La Bayonnaise	1938		
			10	L`Incomprise	1938		
			11	Baliste	1938		
			12	Branlebas	1938		
			13	Bouclier	1938		

## SUBMARINES

Requin	9	1	Requin	1926		<p>1150/1441t, 78.3x6.8x5.1m, 2d/em, 2900/1800hp, 15/9kts, 51p, 80m; 1x1-100/45, (6+2x2)-550TT</p>
		2	Souffleur	1926		
		3	Narval	1926		
		4	Marsouin	1927		
		5	Dauphin	1927		
		6	Espadon	1927		
		7	Caïman	1927		
		8	Morse	1928		
		9	Phoque	1928		
Sirène	3	10	Sirène	1927		<p>609/757t, 64.0x5.2x4.3m, 2d/em, 1300/1000hp, 14/7.5kts, 41p, 80m; 1x1-75/35, (5+1x2)-550TT</p>
		11	Naïade	1927		
		12	Galathée	1927		
Ariane	3	13	Ariane	1929		<p>626/787t, 66.0x6.2x4.1m, 2d/em, 1250/1000hp, 14/7.5kts, 41p, 80m; 1x1-75/35, (5+1x2)-550TT</p>
		14	Eurydice	1929		
		15	Danaé	1929		
Circé	4	16	Circé	1929		<p>615/776t, 62.5x6.2x4.0m, 2d/em, 1250/1000hp, 14/7.5kts, 41p, 80m; 1x1-75/35, (5+1x2)-550TT</p>
		17	Calypso	1929		
		18	Thétis	1929		
		19	Doris	1930		
Saphir	6	20	Saphir	1930		<p>761/925t, 65.9x7.2x4.3m, 2d/em, 1300/1000hp, 12/9kts, 42p, 80m; 1x1-75/35, 1x2-13.2, 2-550TT, 1x(1-550+2-400)TT, 32m</p>
		21	Turquoise	1930		
		22	Rubis	1933		
		23	Diamant	1934		
		24	Nautilus	1937		
		25	Perle	1937		
		26	Redoutable	1931		

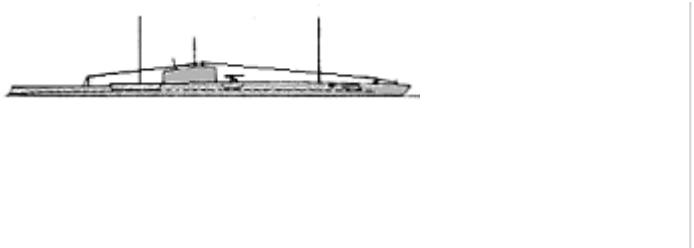
SS	Redoutable	17	27	Vengeur	1931		1570/2084t, 92.3x8.2x4.7m, 2d/em, 6000/2000hp, 17/10kts, 61p, 80m; 1x1-100/45, 1x2-13.2, (4+1x3)-550TT, 1x(2-550+2-400)TT
			28	Fresnel	1931		
			29	Henri Poincaré	1931		
			30	Pascal	1931		
			31	Actéon	1931		
			32	Archimède	1932		
			33	Monge	1932		
			34	Pasteur	1932		
			35	Poncelet	1932		
			36	Achéron	1932		
			37	Protée	1932		
			38	Pégase	1932		
			39	Achille	1933		
			40	Argo	1933		
			41	Ajax	1934		
			42	Persée	1934		
			L'Espoire	6	43		
44	Le Glorieux	1934					
45	Le Centaure	1935					
46	Le Héros	1936					
47	Le Conquérant	1936					
48	Le Tonnant	1937					
Agosta	6	49	Sfax	1936		1570/2084t, 92.3x8.2x4.7m, 2d/em, 8000/2000hp, 20/10kts, 61p, 80m; 1x1-100/45, 1x2-13.2, (4+1x3)-550TT, 1x(2-550+2-400)TT	
		50	Agosta	1937			
		51	Casabianca	1937			
		52	Béziers	1937			
		53	Ouessant	1939			
		54	Sidi Ferruch	1939			
Argonaute	5	55	Argonaute	1932		630/798t, 63.4x6.4x4.2m, 2d/em, 1300/1000hp, 14/9kts, 41p, 80m; 1x1-75/35, (4+1x2)-550TT, 1x2-400TT	
		56	Aréthuse	1933			
		57	Atalante	1934			
		58	La Vestale	1934			
		59	La Sultane	1935			
Diane	9	60	Diane	1932		651/807t, 64.4x6.2x4.3m, 2d/em, 1400/1000hp, 14/9kts, 41p, 80m; 1x1-75/35, (4+1x2)-550TT, 1x2-400TT	
		61	Méduse	1932			
		62	Antiope	1932			
		63	Amphitrite	1933			
		64	Amazone	1933			

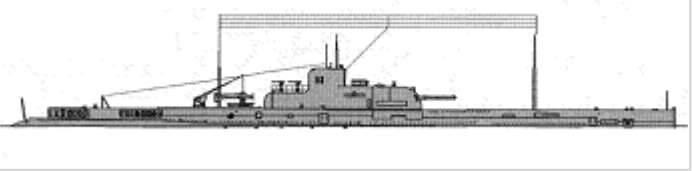
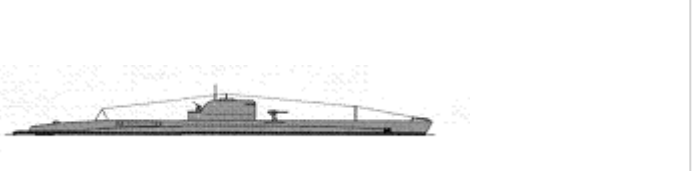



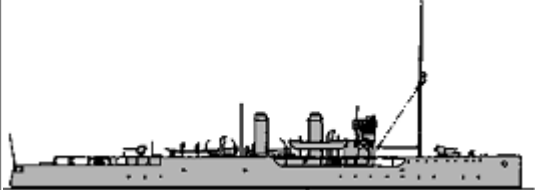
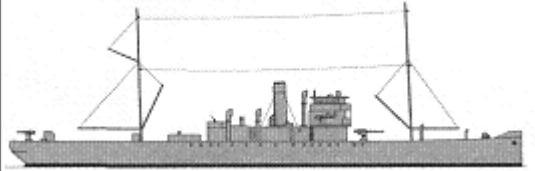
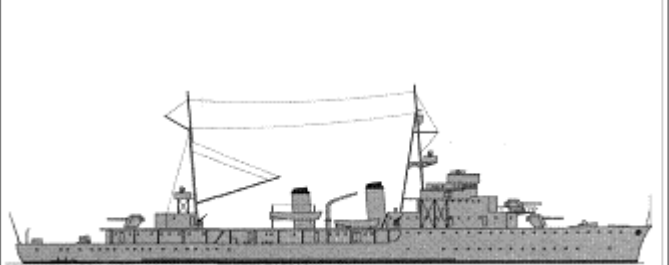

						
		65	Orphée	1933		
		66	Oréade	1933		
		67	La Psyché	1933		
		68	La Sybille	1934		
Orion	2	69	Orion	1932		656/822t, 66.8x6.2x4.4m, 2d/em, 1400/1000hp, 14/9kts, 41p, 80m; 1x1-75/35, (4+1x2)-550TT, 1x2-400TT
		70	Ondine	1932		
Surcouf	1	71	Surcouf	1934		3250/4304t, 110.0x9.0x7.3m, 2d/em, 7600/3400hp, 18.5/10kts, 118p, 80m; 1x2-203/50, 2x1-37/50, 2x2-13.2, (4+1x4)-550TT, 1x4-400TT, 1seaplane (MB.411)
Minerve	6	72	Iris	1936		662/856t, 68.1x5.6x4.0m, 2d/em, 1800/1230hp, 14.5/9kts, 42p, 80m; 1x1-75/35, 2x1-13.2, 6-550TT, 1x3-400TT
		73	Minerve	1936		
		74	Vénus	1936		
		75	Junon	1937		
		76	Pallas	1939		
		77	Cérès	1939		

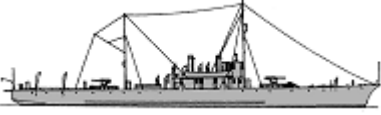
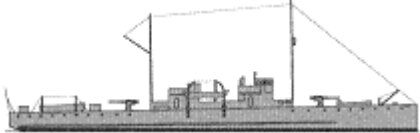
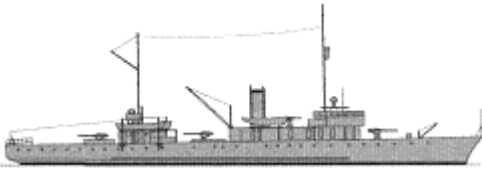
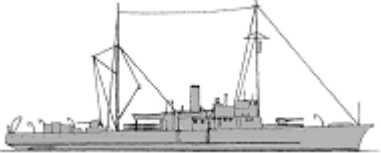
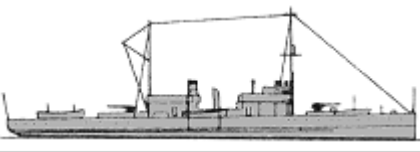
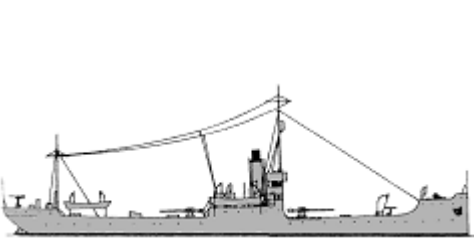
## ESCORTS

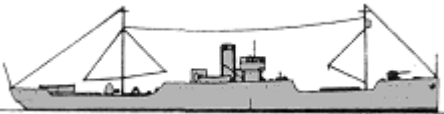
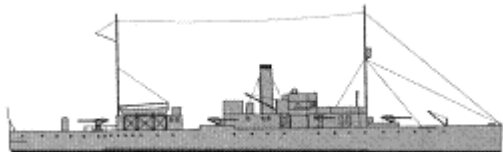
SL	Aldébaran	1	1	Altair	1916		1470t, 81.5x10.5x4.2m, 2b,1vte, 2800hp, 17.5kts, 103p; 2x1-139/45, 2x1-75/35, 2DCT, 1DCR
	Andromédé	1	2	Ville d'Ys	1917		1250t, 83.5x12.0x5.0m, 2b,1vte, 2675hp, 17kts, 103p; 1x1-100/45, 3x1-75/35, 2x1-47/40
	Bougainville	7	3	Dumont d'Urville	1932		2600t, 103.7x12.7x4.5m, 2d, 3200hp, 15.5kts, 183p; 3x1-139/40, 4x1-37/50, 50m, 1seaplane (GL.832)
			4	Bougainville	1932		
			5	Savorgnan de Brazza	1932		
			6	D'Entrecasteaux	1933		
			7	Rigault de Genouilly	1933		
			8	Amiral Charner	1933		
			9	D'Iberville	1935		
			1	Marigot	1932		4048brt, 104.6x16.0x6.0m, 1d, 4000hp, 15kts; 4x1-100/45
		2	Cyrnos	1929		2548brt, 94.4x12.6x5.2m, 2d, 3900hp, 14kts; 5x1-100/45	

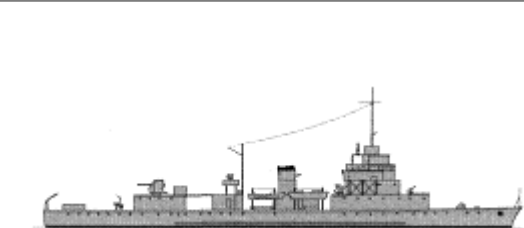
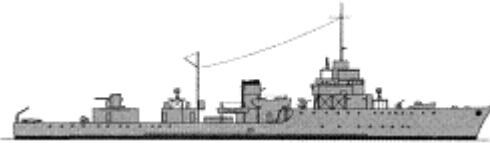



ASL -	15	3	Sidi Okba	1930		2824brt, 100.8x13.2x5.6m, 1vte, 1900hp, 15kts; 5x1-100/45			
		4	Ville d' Ajaccio	1929		2444brt, 85.2x12.6x5.8m, 1vte, 3100hp, 16kts; 5x1-100/45			
		5	Caraibe	1932		4048brt, 104.6x16.0x6.0m, 1d, 4000hp, 15kts; 4x1-100/45			
		6	Pascal Paoli	1932		3280brt, 96.0x14.6x5.2m, 2t, 5800hp, 18kts; 5x1-100/45			
		7	Sampiero Corso	1936		3823brt, 105.5x14.6x5.4m, 2t, 5100hp, 16kts; 5x1-100/45			
		8	Léoville	1922		1049brt, 65.4x9.3x4.5m, 1vte, 850hp, 11.5kts; 4x1-100/45, 2x1-37/50, 2DCR			
		9	Barsac	1922		1049brt, 65.4x9.3x4.5m, 1vte, 850hp, 10kts; 4x1-100/45, 2x1-37/50, 2DCR			
		10	Cérons	1923		1049brt, 65.4x9.4x4.5m, 1vte, 850hp, 10.5kts; 4x1-100/45, 2x1-37/50, 2DCR			
		11	Sauternes	1922		1049brt, 65.4x9.3x4.5m, 1vte, 850hp, 10kts; 4x1-100/45, 2x1-37/50, 2DCR			
		12	Médoc	1930		1166brt, 72.3x10.4x4.9m, 1vte, 900hp, 10kts; 4x1-100/45, 2x1-37/50, 2DCR			
		13	Pomerol	1930		1167brt, 72.3x10.4x4.9m, 1vte, 900hp, 11kts; 4x1-100/45, 2x1-37/50, 2DCR			
		14	Pessac	1907		878brt; 4x1-100/45, 2x1-37/50, 2DCR			
		15	Listrac	1907		878brt; 4x1-100/45, 2x1-37/50, 2DCR			
		FS	Ardent	4	1	Audacieuse	1917		400(3)-410(1,2,4)t, 60.2x7.2x2.9m, 2b,1vte(3)-2vte(1,2,4), 1200-2200hp, 14-17kts, 55-60p; 2x1-145/45(3), 2x1-100/45(1,2,4), 2DCT, MS
					2	Dédaigneuse	1917		
3	Étourdi				1917				
4	Tapageuse				1917				
Friponne	2		5	Diligente	1918		315t, 66.4x7.0x2.8m, 2d, 900hp, 14.5kts, 54p; 2x1-100/45, 2DCT		
			6	Engageante	1918				
Marne	3		7	Marne	1917		601(7)-566(8,9)t, 78.0x8.9x3.4m, 2b,2gt, 5000(7)-4000(8,9)hp, 21(7)-20(8,9)kts, 113p; 4x1-100/45, 2x1-65/50(9), 1DCR		
			8	Somme	1917				
			9	Yser	1917				
Luronne	1		10	Luronne	1917		400t, 60.2x7.2x2.9m, 2d, 630hp, 13.7kts, 54p; 2x1-100/45, 2DCT		
Conquérante	1		11	Conquérante	1917		457t, 66.4x7.9x2.8m, 2d, 1800hp, 17kts, 54p; 2x1-100/45, 2DCT		
Amiens	8		12	Arras	1918		850t, 74.9x8.7x3.2m, 2b,2gt, 5000hp, 20kts, 103p; 2x1-145/45(17), 2x1-139/55(12-15,16-19), 1x1-75/35, 2DCT, 1seaplane (GL.832(14))		
			13	Amiens	1920				
			14	Belfort	1920				
			15	Calais	1920				
			16	Coucy	1920				
			17	Épinal	1920				
			18	Lassigny	1920				
19	Tahure		1920						

	Ailette	1	20	Ailette	1918		492t, 70.0x8.3x3.1m, 2b,2gt, 4000hp, 20kts, 107p; 4x1-100/45, 1x1-75/35
	Scarpe	2	21	Ancre	1918		604t, 76.2x8.7x3.3m, 2b,2gt, 5000hp, 20kts, 107p; 4x1-100/45, 1x1-75/35, 2DCT
			22	Suiippe	1918		
	Flamant	1	23	Quentin Roosevelt	1918		585t, 50.0x8.4x5.8m, 2b,1vte, 1200hp, 14.5kts, 53p; 1x1-75/35, 1x1-47/50
	Dubordieu	1	24	Dubordieu	1918		453t, 64.9x8.2x3.1m, 2b,2gt, 2000hp, 16.5kts, 74p; 1x1-139/45, 1x1-100/45, 2DCT
	Élan	5	25	Élan	1939		895t, 78.3x8.7x3.3m, 2d, 4000hp, 20kts, 106p; 1x1-100/45 or 1x2-90/50, (1x4+2x2)-13.2, 2DCT, 1DCR
			26	Commandant Bory	1939		
			27	Commandant Delage	1939		
			28	Commandant Duboc	1939		
			29	Commandant Rivière	1939		
	Chamois	3	30	Chamois	1939		900t, 78.3x8.7x3.3m, 2d, 4000hp, 20kts, 106p; 1x1-100/45 or 1x2-90/50, (1x4+2x2)-13.2, 2DCT, 1DCR
			31	Chevreuil	1939		
			32	Gazelle	1939		
SC	C1	5	1 - 5	C25, 26, 31, 81, 98	1917 - 1918		85t, 33.5x4.7x2.3m, 3pe, 660hp, 16.5kts, 27p; 1x1-75/35, 1DCT
	C101	2	6	Ch106	1919		150t, 43.4x5.2x2.4m, 2b,2vte, 1300hp, 16.5kts, 31p; 1x1-75/35, 1DCT
			7	Ch107	1919		
	Ch1	4	8	Ch1	1934		180t, 48.1x5.5x1.9m, 2d, 2400hp, 20kts, 41p; 1x1-75/35, 4DCT, 1DCR, MS
			9	Ch2	1934		
10			Ch3	1934			
11			Ch4	1934			
Loup	3	1	Loup	1917	No picture	285t, 1b,1vte, 600hp, 10kts; 1x1-75/35	
		2	Marcassin	1917			
		3	Sanglier	1917			
Hippopotame	4	4	Mammoth	1917	No picture	970t, 2b,1vte, 1800hp, 12kts; 2x1-75/35	
		5	Hippopotame	1918			
		6	Rhinocéros	1918			

		7	Mastodonte	1919				
Aurochs	4	8	Zébu	1917	No picture	290t, 1b,1vte, 650hp, 10kts; 1x1-90/24, 1x1-47/40		
		9	Aurochs	1918				
		10	Renne	1918				
		11	Élan II	1919				
		12	Clameur	1918				
Clameur	3	13	Tumulte	1918	No picture	370t, 2b,1vte, 720hp, 12kts; 1x1-90/24		
		14	Vacarme	1918				
		15	Athlete	1917				
Athlete	2	16	Lutteur	1919	No picture	585t, 1b,2vte, 500hp, 12kts; 2x1-120/40		
		17	Malakoff	1918				
Navarin	1	17	Malakoff	1918	No picture	640t, 1vte, 500hp, 11kts, 31p; 1x1-100/45		
PC	Mauviette	1	18	Passereau II	1918		460t, 43.5x7.3x4.2m, 1b,1vte, 10kts; 1x1-90/24, 1x1-47/40, MS	
		Pluvier	8	19	Faisan	1918	No picture	(680-780)t, 1vte, 750hp, 11kts
				20	Gelinotte	1918		
				21	Heron II	1918		
				22	Paon	1918		
				23	Pingouin II	1918		
				24	Pintade	1918		
				25	Ramier	1918		
				26	Tourterelle	1918		
		Crabe	9	27	Cèdre	1918	No picture	(360-370)t, 1b,1vte, 400hp, (9-10)kts; 1x1-90/24
28	Chêne			1918				
29	Crabe			1918				
30	Erable			1918				
31	Orme			1918				
32	Frêne			1919				
33	Hêtre			1919				
34	Peuplier			1919				
35	Calmar			1920				
		1	Cap Nord	1926		1033brt, 64.3x10.4x6.0m, 1vte, 950hp, 10.5kts; 3x1-100/45		
		2	Cap Fagnet	1926		1017brt, 64.3x10.4x6.0m, 1vte, 950hp, 10.5kts; 3x1-100/45		
		3	Heureux	1930		1116brt, 64.2x10.4x6.1m, 1vte, 800hp, 10kts; 3x1-100/45, 2x1-37/50		
		4	Groënland	1930		1178brt, 65.7x10.6x5.5m, 1vte, 325hp, 10kts; 3x1-100/45, 2x1-37/50		
		5	Jutland	1934		1160brt, 66.3x10.9x6.0m, 1d, 1000hp, 11kts; 3x1-100/45, 2x1-37/50, 2DCR		
		6	Mercéditta	1934		1160brt, 66.6x10.5x5.9m, 1d, 1000hp, 12kts; 3x1-100/45, 2x1-37/50		
		7	Président Houduce	1930		1178brt, 65.7x10.6x5.5m, 1d, 925hp, 10kts; 3x1-100/45, 2x1-37/50		
		8	Vikings	1935		1150brt, 63.7x10.5x5.5m, 1vte, 1250hp, 11kts; 3x1-100/45, 2x1-37/50		
		9	Minerva	1937		1148brt, 66.6x10.5x5.9m, 1d, 1000hp, 12kts; 3x1-100/45, 2x1-37/50		

APC -	28	10	Sergent Gouarne	1928		1146brt, 66.3x10.1x5.7m, 1vte, 850hp, 10.5kts; 3x1-100/45, 2x1-37/50, 1DCT, 2DCR
		11	Aspirant Brun	1928		1131brt, 66.3x10.1x5.7m, 1vte, 850hp, 10.5kts; 3x1-100/45, 2x1-37/50, 1DCT, 2DCR
		12	Casoar	1935		580t
		13	Capricorne	1921		741t; 3x1-100/45
		14	Victoria	1928		849t; 3x1-100/45
		15	Vaillant	1921		916t; 3x1-100/45
		16	Clairvoyant	1922		943t; 3x1-100/45
		17	Hardi II	1921		916t; 3x1-100/45
		18	Terre Neuve	1921		780t; 3x1-100/45
		19	Capitaine Armand	1920		584t; 3x1-100/45
		20	Téméraire II	1926		965t; 3x1-100/45
		21	Atlantique	1920		659t; 3x1-100/45
		22	Asie	1914		551t; 3x1-100/45
		23	Patrie	1920		753t; 3x1-100/45
		24	Reine des Flots	1923		849t; 3x1-100/45
		25	Aiglon	1907		305t; 2x1-100/45
		26	Notre Dame d'Espérance	1919		310t; 2x1-100/45
		27	Ambroise Paré	1906		326t; 2x1-100/45
28	Mouette	1906		302t; 2x1-100/45		

## OTHER FIGHTING SHIPS

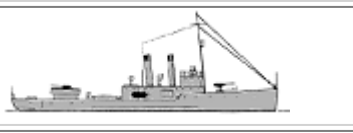
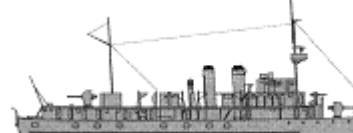
PR	Doudart de la Grée	1	1	Doudart de la Grée	1909		183t, 54.4x6.7x1.0m, 2b,2vte, 900hp, 14kts, 66p; 1x1-75/35, 2x1-37/23
	Balny	1	2	Balny	1920		226t, 54.4x6.7x1.0m, 2b,2vte, 900hp, 14kts, 59p; 2x1-75/35, 2x1-37/23
	Vigilante	2	3	Vigilante	1923		218t, 51.8x7.7x1.2m, 2b,2vte, 600hp, 12kts, 42p; 2x1-75/35, 2x1-37/23
			4	Argus	1923		
	Ch101	2	5	Commandant Bourdais	1920		150t, 43.4x5.2x2.4m, 2b,2vte, 1300hp, 16.5kts, 31p; 1x1-75/35
			6	Avalanche	1920		
	Francis Garnier	1	7	Francis Garnier	1931		639t, 62.5x10.3x2.2m, 2b,2vte, 3200hp, 15kts, 103p; 2x1-100/45, 1x1-75/50, 2x1-37/50
	Mytho	2	8, 9	Mytho, Tourane	1933 - 1936	No picture	95t, 35.0x5.4x0.9m, 2d, 250hp, 10kts; 1x1-75/35, 1x1-47/40, 1x1-81/8mortar

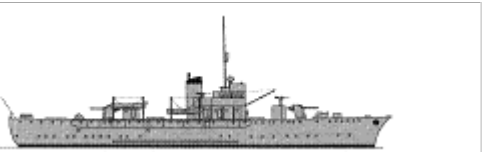
AGS	Amiral Mouchez	1	1	Amiral Mouchez	1937		970t, 62.0x10.3x3.4m, 1d, 800hp, 12kts, 81p; 2x1-100/45
-----	----------------	---	---	----------------	------	---	---

## COASTAL FORCES

PT	VTB1	3	1 - 3	VTB1 - 3	1928		11t, 18.3x3.4x0.9m, 2pe, 900hp, 40kts, 5p; 2-400TT
	VTB8	1	4	VTB9	1935	No picture	28t, 18.9x4.9x1.2m, 2pe, 2200hp, 46kts; 2-400TT, 1DCR
	VTB10	1	5	VTB10	1936	No picture	28t, 20.0x4.0x1.2m, 2pe, 2600hp, 45kts; 2-400TT, 1DCR
	VTB11	2	6, 7	VTB11, 12	1939	No picture	28t, 20.0x4.0x1.2m, 2pe, 2200hp, 45kts; 2-400TT, 1DCR
AYP	-	5	1	Alcyon	1919		236t
			2	Notre Dame de Lourdes	1918		236t
			3	Odet	1908		212t
			4	Jean d'Agrève			112t
			5	Loup de Mer	1922		228t

## MINE WARFARE SHIPS

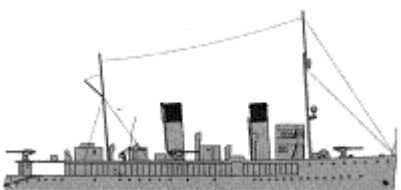
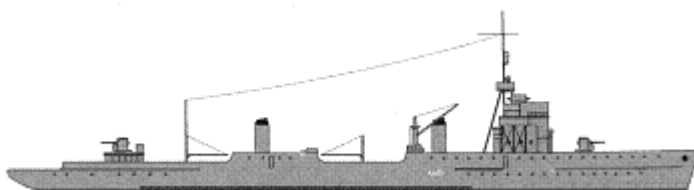
AML	-	4	1	Castor	1916		4576t, 75.2x17.3x6.4m, 6b,3vte, 6400hp, 14kts; 4x1-100/45, 2x1-37/50, 268m
			2	Pollux	1917		2463t, 64.2x15.5x6.0m, 6b,3vte, 4000hp, 14kts; 4x1-100/45, 2x1-37/50, 236m
			3	Indéfatigable	1899		1142brt
			4	Samson	1907		660t
NL	Le Gladiateur	1	1	Le Gladiateur	1935		2293t, 113.0x12.7x3.5m, 2b,2gt, 6000hp, 18kts, 132p; 4x1-90/50, nets
MS	Clameur	1	1	Fracas	1917	No picture	370t, 2b,1vte, 720hp, 12kts; 1x1-90/24, MS
	Pluvier	4	2	Canard	1918	No picture	(680-780)t, 1vte, 750hp, 11kts; MS
			3	Coq	1918		
			4	Pigeon	1918		
	Crabe	2	5	Tourteau	1918	No picture	(360-370)t, 1b,1vte, 400hp, (9-10)kts; 1x1-90/24, MS
			6	Homard	1920		
Granit	1	7	Granit	1918		360t, 57.6x7.9x2.3m, 1b,1vte, 600hp, 12.5kts, 63p; 2x1-65/50, MS	

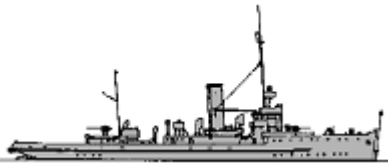
						
Albâtre	1	8	Meulière	1919		380t, 57.6x7.9x2.3m, 1b,1vte, 500hp, 10.5kts, 63p; 1x1-65/50, MS
M27	1	9	Nymphe II	1916		507t, 58.4x7.3x2.3m, 2b,2vte, 1800hp, 16.5kts, 40p; 2x1-105/45, 30m, MS
		1	Robuste	1914		235t
		2	Sioux	1918		336t
		3	Djebel Sannin	1931		350t
		4	Estérel	1930		333t
		5	Gabès	1931		333t
		6	Kairouan	1931		333t
		7	Lamentin	1931		350t
		8	Sousse	1930		333t
		9	Jeanne Schiaffino	1922		1220brt, 66.8x9.9m, 1vte, 10kts
		10	Ville de Bougie	1907		1132brt; 77.9x11.0m, 1vte, 13.5kts
		11	Mascot	1922		1256brt; 72.6x11.0m, 1vte
		12	Béarnais	1920		1162brt
		13	Etoile du Nord	1917		317t
		14	Louise et Marie	1916		265t
		15	St-Benoit	1917		315t
		16	Couronne	1935		224t
		17	St-Jpachim	1914		192t
		18	Vétéran	1920		253t
		19	Frédéric Sauvage	1928		329t
		20	Le Matelot	1934		260t
		21	Caporal Peugeot	1923		102t
		22	Yma			
		23	Notre Dame des Dunes	1931		481t
		24	Madeleine Louise	1933		464t
		25	Caid Fassi			
		26	Madeleine	1912		151t
		27	Le Duquesne	1936		189t
		28	Henri Guégan	1935		251t
		29	Trouville	1910		293t

30	Pierre Descelliers	1933		153t
31	Emile Deschamps	1922		348t
32	Port Melin	1911		240t
33	Marguerite Rose	1931		409t
34	Étienne Rimbert	1935		197t
35	Monique Camille	1934		277t
36	Mardyck			
37	Léopold Soublin	1918		215t
38	Lucien Gougy	1935		150t
39	André et Louis	1907		284t
40	Jacques Coeur	1907		285t
41	Tartarin	1931		288t
42	Ventôse	1936		185t
43	Dijonnais	1934		389t
44	Geneviève	1917		224t
45	Tarana	1932		346t
46	Adolphe Leprince	1926		343t
47	Lucienne Jeanne	1917		286t
48	Maris Stella	1907		285t
49	Charles Vaillant	1916		224t
50	Messidor	1908		243t
51	Gâtinais	1933		389t
52	Elisabeth Thérèse	1935		156t
53	Castelnau	1918		336t
54	Le Slack			276t
55	Denis Papin	1917		309t
56	Augustin Normand	1894		175t
57	Tatiana	1937		178t
58	Edmond René	1907		288t
59	Fructidor	1918		306t
60	Patrice II	1907		247t
61	Maria Élena	1932		146t
62	Louise Anais			170t
63	Le Bretonnière	1907		628t
64	Nadine	1919		274t
65	Pierre Gustave	1932		217t
66	Ailly	1907		203t
67	Nivôse II	1936		185t
68	Gaulois	1907		301t
69	Nivernais	1933		388t
70	Jean Parmentier	1931		127t

71	Bar	1907	254t
72	Jacques Jean	1905	244t
73	Pluviôse	1937	150t
74	Vierge de Massabielle	1925	201t
75	Cap d' Antifer	1912	294t
76	Rosemonde	1910	364t
77	Angèle Marie	1929	238t
78	St-Dominique	1921	330t
79	Les Frères Coquelin	1934	185t
80	High Tide	1919	106t
81	Vénus II	1906	264t
82	Cap Ferrat	1936	139t
83	Jean Ribault	1933	152t
84	Notre Dame de Lorette	1937	339t
85	Vierge de Lourdes	1917	154t
86	Emma	1924	255t
87	Bernadette	1914	302t
88	Christiane Cécile	1932	146t
89	Congre	1918	298t
90	Chasse Marée	1920	250t
91	Edouard Gougy	1936	155t
92	Otello	1931	113t
93	Gardien Cosmao		
94	Beaulne Verneuil	1919	268t
95	Kerpape	1919	253t
96	Courlis	1919	208t
97	Rien Sans Peine		142t
98	Président Briand	1932	227t
99	Monique Andrée	1920	221t
100	Keryado	1918	252t
101	Flamant	1917	236t
102	Elle	1904	199t
103	Roche Françoise	1919	208t
104	Roche Velen	1918	208t
105	Bisson	1908	259t
106	Laita	1908	215t
107	Duconédic	1908	259t
108	Donibane	1912	186t
109	Petit André Jean	1932	134t
110	Pen Men II	1917	253t



111	Tess II	1916		128t
112	Marélyn			
113	Tadorna	1936		227t
114	Keriarvor	1919		228t
115	Alma II	1936		276t
116	Kergroise	1918		261t
117	Keroman	1918		261t
118	Edith Germaine	1933		130t
119	Marie Paulette II			
120	Isole	1908		215t
121	Odet II	1908		212t
122	Président Paul Doumer	1916		250t
123	Guédel	1930		232t
124	Roche Grise	1919		208t
125	Ibis	1919		208t
126	Ker Ysa	1919		228t
127	Marie Mad	1918		284t
128	Marie Thérèse II	1919		288t
129	Henry Caméleyre	1908		218t
130	Banderole	1933		146t
131	Joseph Élise	1932		113t
132	Le Violent	1930		440t
133	Marie Yette	1918		286t
134	Marie Gilberte	1918		286t
135	Picorre	1914		287t
136	Cerbère	1906		382t
137	Pierre Loti II	1932		171t
138	Sherki			
139	Galopin	1917		198t
140	Grèbe	1907		204t
141	Héron I	1911		275t
142	Goéland X	1918		236t
143	La Coubre	1912		253t
144	Roche Bleue	1919		208t
145	Gaston Bouineau	1932		130t
146	Cap Noir	1923		224t
147	La Blanche II	1919		296t
148	Loup de Mer			237t
149	Men Gwen	1920		242t
150	St-Christophe	1913		245t
151	Madone de Pompei			

AMS -

252

152	Flèche Blanche	1932		100t
153	Givenchy	1907		223t
154	Auguste Denise	1920		278t
155	Socoa	1928		123t
156	Notre Dame d`Afrique	1891		230t
157	Capitaine Teissier	1931		134t
158	Lézardrieux	1922		933t
159	Galéjade			
160	Poitou	1912		309t
161	Le Cid	1933		248t
162	Alcyon II	1919		236t
163	Jean d`Agrève			112t
164	St-Brieuc	1904		461t
165	Aigrette	1919		208t
166	Yves Ellyet	1928		105t
167	St-Charles	1917		366t
166	Bienvenu			118t
167	Pen men	1917		253t
168	Ville de Ténès	1919		390t
169	Fleur de Mai			
170	Tirrena			
171	Procida			
172	Gascogne	1914		309t
173	Enseigne	1931		135t
174	Les Issers	1920		726t
175	Angèle Caméleyre	1908		232t
176	Sidi Premier			
177	St-Joseph	1908		905t
178	St-Victorine	1932		
179	Ville de Tipaza	1917		331t
180	Penfret II	1918		299t
181	Lilias	1922		239t
182	Grouin du Cap	1918		297t
183	Raymond			
184	Gosse	1917		300t
185	Ravignan	1920		264t
186	Alfred Beaugé			109t
187	Grondin			
188	Cinq Frères			
189	Antioche II	1918		300t

190	Kérolay	1917	252t
191	St-Guënaël	1908	251t
192	Avocette	1912	247t
193	Jean Mic		
194	Comte Beniowsky		
195	Gouverneur Mouttet	1931	467t
196	Balata	1922	312t
197	Maud		
198	De Lanessan	1919	240t
199	Béryl	1920	670t
200	Gâcheur		
201	Capitaine Coulon		
202	Paul Bert		
203	Jean Dupuis		682t
204	Directeur Général Picanon		
205	Ivindo	1926	132t
206	Jupiter	1915	123t
207	Kaolack	1925	125t
208	Lion II	1912	278t
209	Kermaria		244t
210	Lavardin	1911	251t
211	Lebou		
212	Gustave Denis	1934	183t
213	Jacques Morgand	1936	155t
214	Mondara	1921	359t
215	Ros Braz	1932	118t
216	Petite Yvette	1932	118t
217	Armand Rousseau		
218	Nora	1934	131t
219	St-Robert		
220	Ombrine		
221	Trois Ilets	1920	338t
222	Roche Noire	1917	208t
223	Hàvre de Grâce	1936	281t
224	Pouyer Quartier		
225	Gustave Merlin		
226	St-Pierre		
227	Charles Léon		
228	Général Foch	1916	264t
229	Tamise	1917	264t
230	Prado	1905	997t

231	Fée des Eaux			
232	Avenir du Pays			
233	Corsaire II			
234	Cap Fréhel			
235	Cap Nègre			
236	Le Cabellou			
237	Cap Bear			
238	Cap Couronne			
239	Yannick Joseph			
240	Cap Griz Nes			
241	Barbue			
242	Cap de la Hague			
243	Chanchardon II	1909		315t
244	La Douve			
245	Eledone	1911		242t
246	Henriette	1907		287t
247	Imbrin	1919		347t
248	Océanie	1922		331t
249	Pierre Descelliers	1933		153t
250	Richelieu	1912		290t
251	Sénateur Louis Brindeau	1911		313t
252	Wagram	1906		335t

#### NAVAL AVIATION (*approximately, maximal number of delivered planes signed*)

Deck planes	B: 24 LN.401 ( <i>delivery till 1940</i> ), 24 LN.411 ( <i>delivery till 1940</i> ), 39 V.156F; R: 30 PL.101
Seaplanes	F: 20 LN.210; TB: 16 PL.15, 29 Laté 298A ( <i>delivery till 1940</i> ), 42 Laté 298B ( <i>delivery till 1940</i> ), 106 Laté 298D ( <i>delivery till 1943</i> ); R: 15 CAMS.37A, 24 GL.810Hy, 20 GL.811Hy, 29 GL.812Hy, 13 GL.813Hy, 22 GL.832Hy, 16 Potez 452, 126 Loire 130M/C ( <i>delivery till 1941</i> )

[home](#)

[World navies yesterday](#)

[1940](#)

# GERMANY 01 January 1940

*IN SERVICE: 2 battleships-predreadnoughts, 2 battlecruisers, 5 seaplane tenders, 3 catapult vessels, 4 heavy cruisers, 6 light cruisers, 3 auxiliary cruisers, 22 destroyers, 21 torpedo boats, 55 submarines, 7 corvettes, 4 patrol ships, 140 auxiliary patrol vessels, 30 auxiliary submarine chasers, 12 auxiliary decoy vessels, 2 gunnery training ships, 1 dispatch vessel, 2 river monitors, 22 motor torpedo boats, 3 motor anti-submarine boats, 1 river patrol launch, 3 minelayers, 7 auxiliary minelayers, 4 mine transports, 2 river minelaying boats, 31 minesweepers, 67 auxiliary minesweepers, 63 minesweeping boats, 15 auxiliary mine destruction vessels*

## CAPITAL SHIPS

BB	Deutschland	1	Schlesien (TS)	1908		13994t, 127.6x22.2x8.3m, 12b, 2vte, 20540hp, 18.5-19kts, 743p; 240belt, 40deck, 280turrets, 300CT; 2x2-283/40, 6x1-105/45, 4x1-37/83, 4x1-20/65
		2	Schleswig-Holstein (TS)	1908		
CB	Scharnhorst	1	Gneisenau	1938		37224t, 235.4x30.0x8.2m, 12b,3gt, 160100hp, 32kts, 1669p; 350belt, 130deck, 360turrets, 350CT; 3x3-283/55, (4x2+4x1)-149/55, 7x2-105/65, 8x2-37/83, 10x1-20/65, 3seaplanes(1, Ar196), 5seaplanes(2,Ar196); radar: FuMO22
		2	Scharnhorst	1939		

## AIRCRAFT CARRYING SHIPS

	Krischan I	1	1	Krischan	1934		250t, 38.2x6.7x2.5m, 2d, 750hp, 15kts, 19p; 1seaplane (He60, He114, Ar196)
	Krischan II	1	2	Gunther Plüschow	1935		700t, 53.8x8.3x2.7m, 2d, 3200hp, 19kts, 30p; 1x1-37/83, 2seaplanes(He60, He114, Ar196)

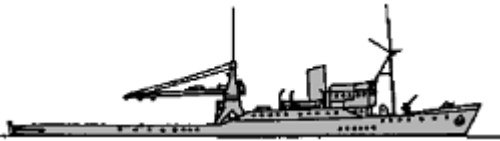
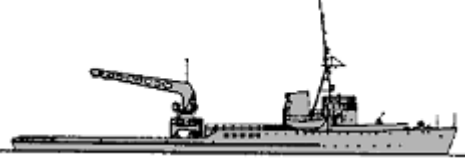
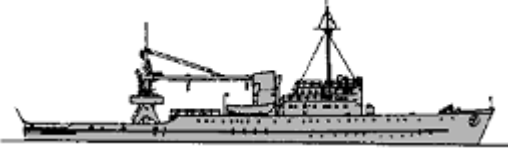
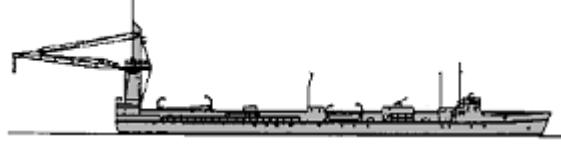
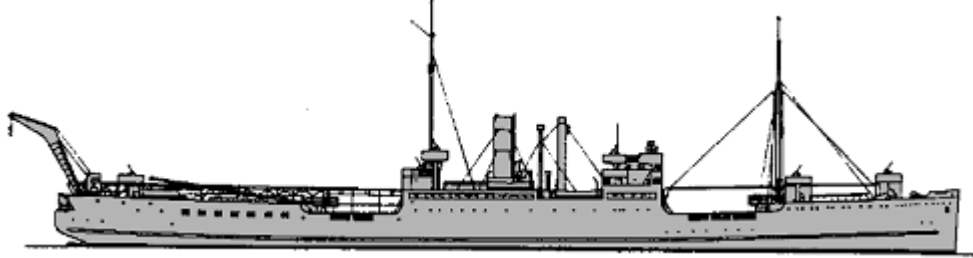
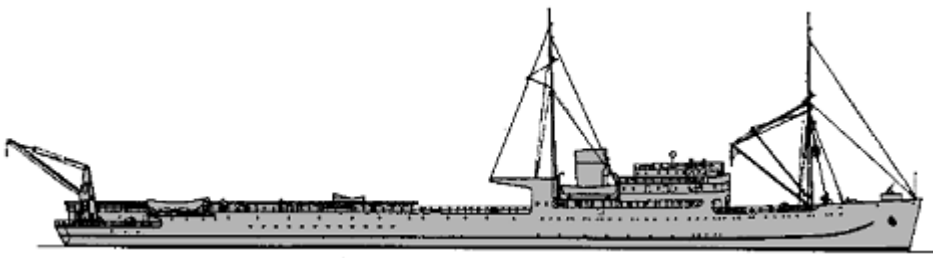
AV						
	Krischan III	1 3	Bernhard von Tschirschky	1935		960t, 77.0x11.0x3.0m, 3d, 4800hp, 20kts, 61p; 3x1-37/83, 2x1-20/65, 2seaplanes(He60, He114, Ar196)
	Greif	1 4	Greif	1937		890t(st), 72.0x10.6x2.7m, 2d, 4400hp, 16kts, 63p; 1x1-20/65, 3seaplanes(He60, He114, Ar196)
	Hans Rolshoven	1 5	Hans Rolshoven	1938		1168t, 76.2x10.6x3.3m, 4d(2), 8800hp, 21kts, 63p; 2x1-20/65, 3seaplanes(He60, He114, Ar196)
AVC	Sperber	1 1	Sperber	1938		1086t(st), 70.3x14.6x1.6m, 2d, 640hp, 8kts, 34p; 2x1-20/65, 1seaplane(Do18)
	Schwabenland	1 2	Schwabenland	1925		16200t, 147.0x18.4x10.0m, 2d, 3600hp, 11kts, 65p; 8x1-20/65, 1seaplane(Do18)
	Friesenland	1 3	Friesenland	1937		11500t, 140.5x16.6x6.0m, 2d, 5800hp, 16kts, 49p; 4x1-20/65, 1seaplane(Do18)

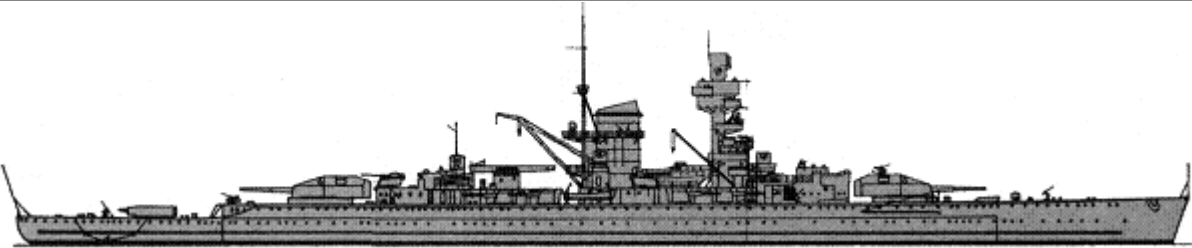

## CRUISERS

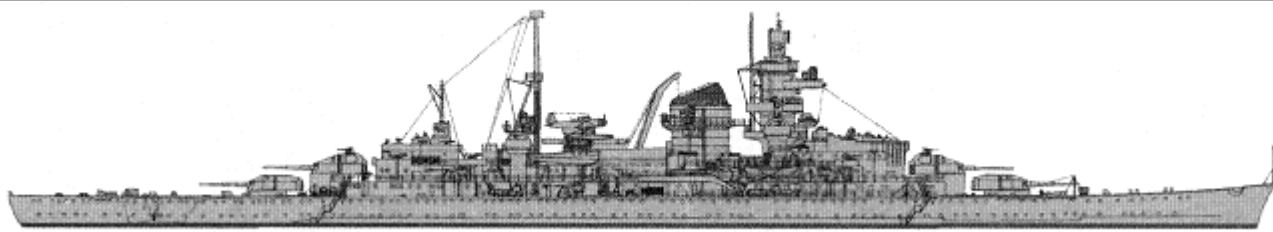
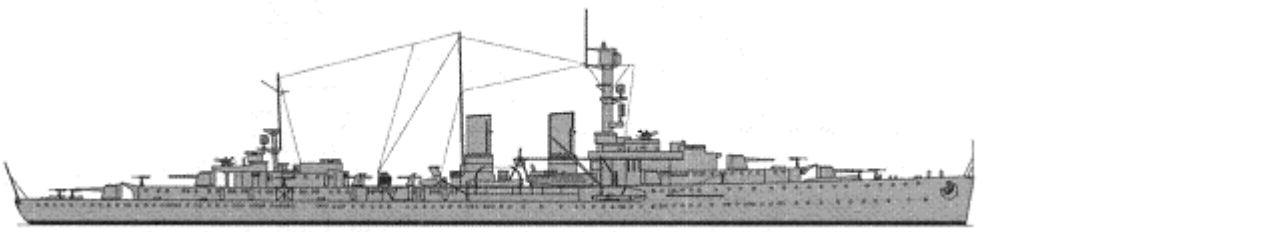
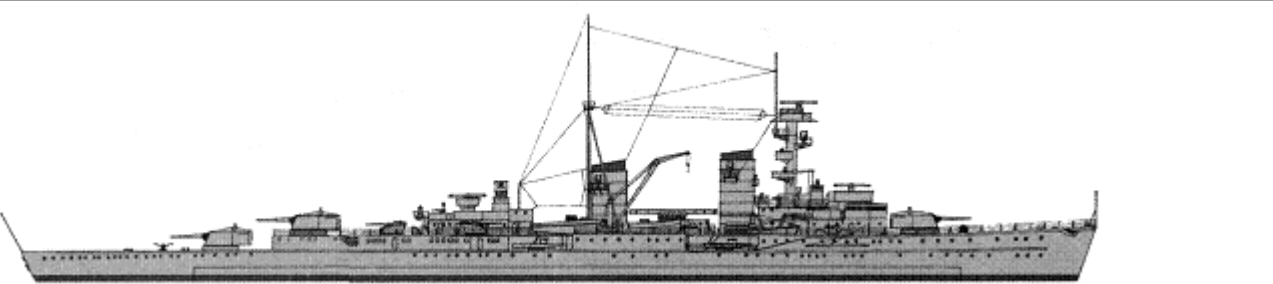
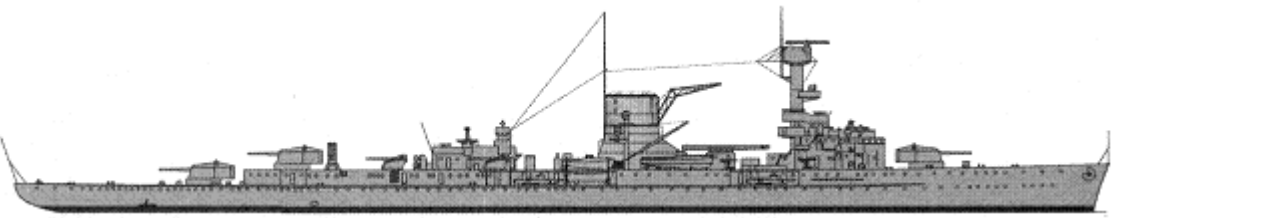
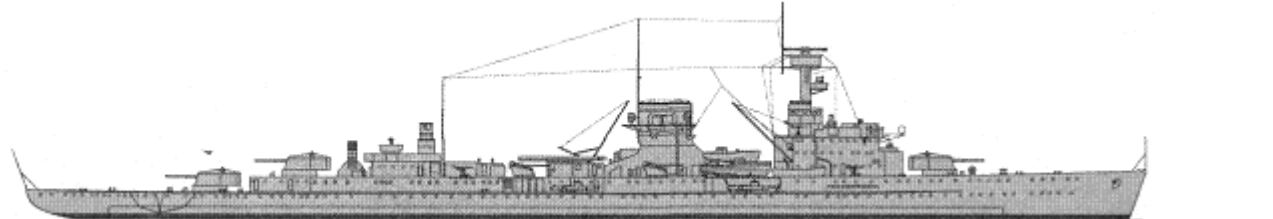
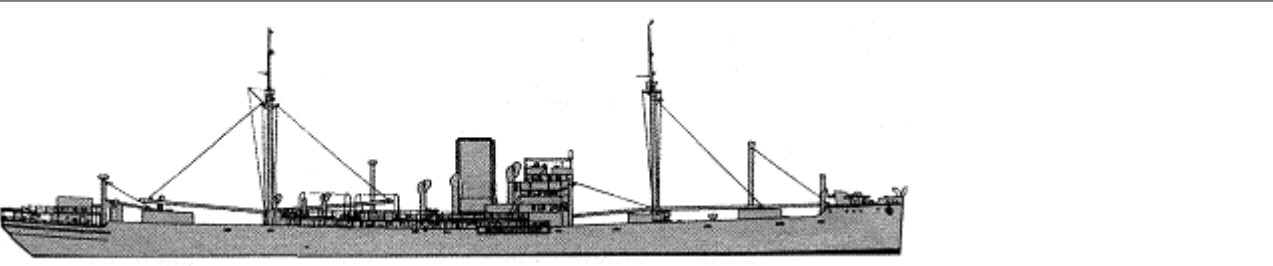
CA		1	Deutschland	1933		14290(1)-15180(2)t, 186.0x20.7(1)-21.3(2)x5.8m, 8d(2), 56800hp, 28kts, 1150p; 80belt, 63(1)-58(2)deck, 150turrets, 150CT; 2x3-283/52, 8x1-149/55, 3x2-88/78, 4x2-37/83, 14x1-20/65(1), 10x1-20/65(2), 2x4-533TT, 2seaplanes(Ar196); radar: FuMO22
	Deutschland	2 2	Admiral Scheer	1934		

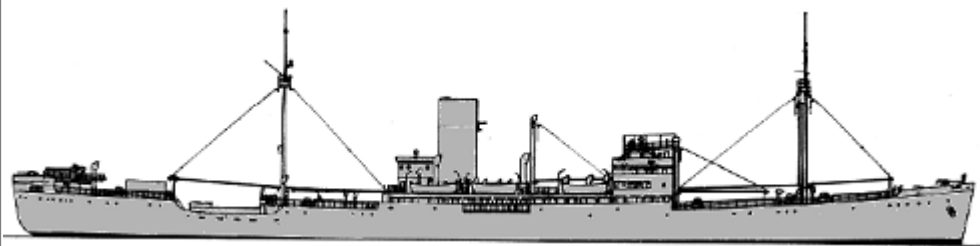

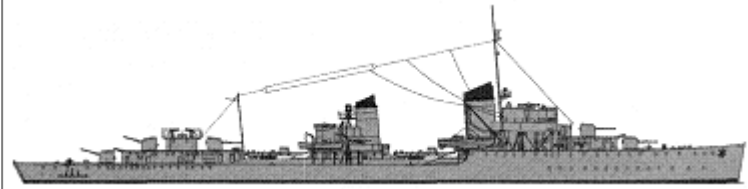
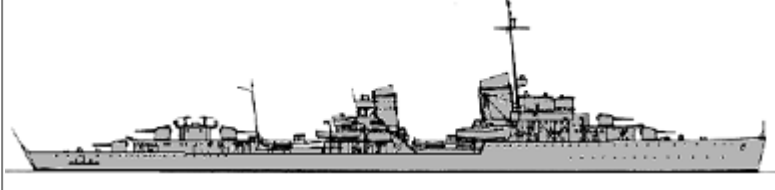

	Admiral Hipper	3	Admiral Hipper	1939		18210t, 205.9x21.3x5.8m, 12b,3gt, 132000hp, 32kts, 1600p; 80belt, 80deck, 160turrets, 150CT; 4x2-203/60, 6x2-105/65, 6x2-37/83, 10x1-20/65, 4x3-533TT, 3seaplanes(Ar196); radar: FuMO22
	Admiral Hipper	2	Blücher	1939		
	Emden	1	Emden	1925		6990t, 155.1x14.3x6.6m, 10b, 2gt, 45900hp, 29kts, 650p; 50belt, 40deck, 20shields, 100CT; 8x1-149/45, 3x1-88/45, 6x1-20/65, 2x2-533TT, 120m
CL	Königsberg	2	Königsberg	1929		7700(2,4)-8350(3)t, 174.0x15.2(2,4)-16.8(3)x5.6m, 6b,2gt/2d(2), 65000/1800hp, 32(2,4)-30(3)kts, 850p; 65(2,4)-79(3)belt, 40(2,4)-56(3)deck, 30turrets, 100CT; 3x3-149/60, 3x2-88/76, 4x2-37/83, 4x1-20/65, 4x3-533TT, 120m, 2seaplanes(2,3,He60)
		3	Karlsruhe	1929		
		4	Köln	1930		
	Leipzig	1	Leipzig	1931		8100t, 177.1x16.3x4.9m, 8b,2gt(2)+4d(1), 72400hp, 32kts, 850p; 50belt, 25deck, 30turrets, 100CT; 3x3-149/60, 3x2-88/76, 4x2-37/83, 4x1-20/65, 4x3-533TT, 120m, 2seaplanes(He60)
	Nürnberg	1	Nürnberg	1935		8900t, 181.3x16.4x4.9m, 8b,2gt(2)+4d(1), 72400hp, 32kts, 896p; 50belt, 25deck, 80turrets, 100CT; 3x3-149/60, 4x2-88/76, 4x2-37/83, 4x1-20/65, 4x3-533TT, 120m, 2seaplanes(He60)
AMC -		1	HSK1 Orion	1930		15700t, 148.0x18.6x8.2m, 4b,gt, 6200hp, 14kts; 6x1-150/45, 1x1-75/35, 1x2-37/83, 4x1-20/65, 2x3-533TT, 228m, 1seaplane(Ar196)
		2	HSK2 Atlantis	1937		17600t, 155.0x18.7x8.7m, 2d, 7600hp, 16kts; 6x1-150/45, 1x1-75/35, 1x2-37/83, 4x1-20/65, 4x1-533TT, 92m, 2seaplanes(He114)

					
		3	HSK3 Widder	1929	16800t, 152.0x18.2x8.3m, 4b,gt, 6200gp, 14kts; 6x1-150/45, 1x1-75/35, 1x2-37/83, 4x1-20/65, 2x2-533TT, 2seaplanes(He114)

### TORPEDO SHIPS

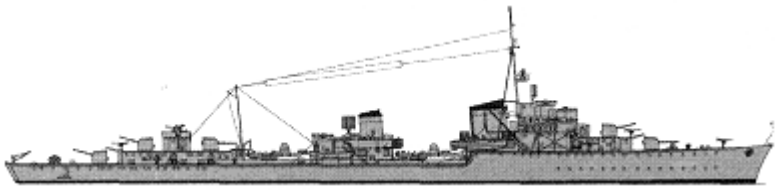

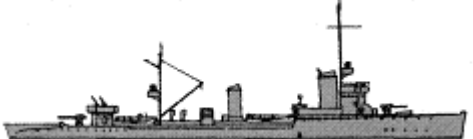

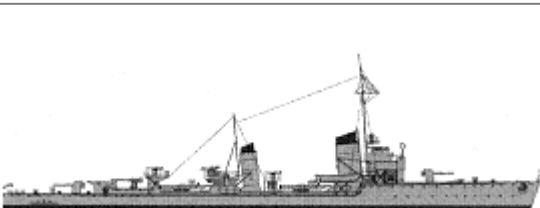
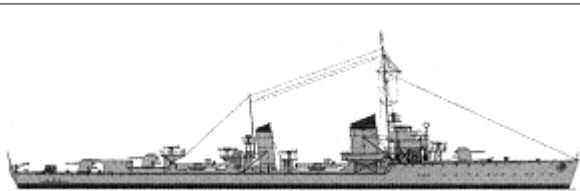
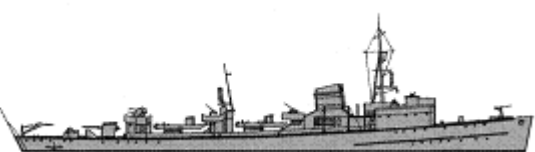
DD	1934	4	1	Z1 Leberecht Maass	1937		3156t, 119.3x11.3x4.2m, 6b,2gt, 70000hp, 38.2kts, 338(1)-315(2-4)p; 5x1-128/45, 2x2-37/83, 6x1-20/65, 2x4-533TT, 4DCT, 60m
			2	Z2 Georg Thiele	1937		
			3	Z3 Max Schultz	1937		
			4	Z4 Richard Beitzen	1937		
	1934A	12	5	Z5 Paul Jacobi	1937		3110(5-8)-3190(9-13)-3165(14-16)t, 119.3(5-8)-121.0(9-16)x11.3x4.2m, 6b,2gt, 70000hp, 38.2kts, 315p; 5x1-128/45, 2x2-37/83, 6x1-20/65, 2x4-533TT, 4DCT, 60m
			6	Z6 Theodor Riedel	1937		
			7	Z7 Hermann Schoemann	1937		
			8	Z8 Bruno Heinemann	1938		
			9	Z9 Wolfgang Zenker	1938		
			10	Z10 Hans Lody	1938		
			11	Z11 Bernd von Arnim	1938		
			12	Z12 Erich Giese	1939		
	1936	6	17	Z17 Diether von Roeder	1938		3415t, 123.0(17-19)-125.1(20-22)x11.8x4.5m, 6b,2gt, 70000hp, 38.5kts, 313(17-19,21,22)-330(20)p; 5x1-128/45, 2x2-37/83, 6x1-20/65, 2x4-533TT, 4DCT, 60m
			18	Z18 Hans Lüdemann	1938		
			19	Z19 Hermann Künne	1939		
			20	Z20 Karl Galster	1939		





							
			21	Z21 Wilhelm Heidkamp	1939		
			22	Z22 Anton Schmitt	1939		
TB	V150	1	1	Eduard Jungmann (TS)	1908		691t, 72.5x7.8x3.0m, 4b,2vt, 10900hp, 30kts, 84p; 1x1-88/45, 2x1-20/65
	G192	1	2	T196	1911		810t, 74.0x7.9x3.0m, 4b,2t, 18200hp, 32kts, 76p; 2x1-105/45, 2x1-20/65
	G7	4	3	T107 (TS)	1912		884t, 76.1x7.6x3.1m, 3b,2t, 16000hp, 30kts, 74p; 1x1-105/45, 2x1-20/65, (1x2+1x1)-500TT, 18m
			4	T108 (TS)	1912		
			5	T110 (TS)	1912		
			6	T111 (TS)	1912		
	1923	6	7	Möwe	1926		1213(7)-1290(8-12)t, 88.8(7)-88.5(8-12)x8.3x2.8m, 3b,2gt, 22100(7)-23000(8-12)hp, 32(7)-33(8-12)kts, 120p; 3x1-105/45, 2x1-20/65, 2x3-533TT, 2DCT, 30m
			8	Greif	1927		
			9	Seeadler	1927		
			10	Albatros	1927		
			11	Falke	1927		
			12	Kondor	1928		
	1924	5	13	Wolf	1928		1320t, 92.6x8.6x2.8m, 3b,2gt, 23000hp, 34kts, 120p; 3x1-105/45(13,14), 3x1-105/55(15-17), 2x1-20/65, 2x3-533TT, 2DCT, 30m
			14	Iltis	1928		
			15	Jaguar	1929		
16			Leopard	1929			
17			Luchs	1929			
1935	4	18	T1	1939		1088t, 84.3x8.6x2.3m, 4b,2gt, 31000hp, 35kts, 119p; 1x1-105/45, 3x1-20/65, 2x3-533TT, 2DCT, 30m	
		19	T2	1939			
		20	T7	1939			
		21	T8	1939			



### SUBMARINES

IA	2	1	U25	1936		862/983t, 72.4x6.2x4.3m, 2d/em, 3080/1000hp, 18.6/8.3kts, 43p, 100m; 1x1-105/45, 1x1-20/65, 6-533TT
		2	U26	1936		
		3	U1	1935		
		4	U2	1935		

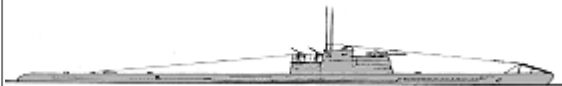
IIA	6	5	U3	1935		254/303t, 40.9x4.1x3.8m, 2d/em, 700/360hp, 13/6.9kts, 22p, 80m; 1x1-20/65, 3-533TT
		6	U4	1935		
		7	U5	1935		
		8	U6	1935		
IIB	16	9	U7	1935		279/328t, 42.7x4.1x3.9m, 2d/em, 700/360hp, 13/6.9kts, 22p, 80m; 1x1-20/65, 3-533TT
		10	U8	1935		
		11	U9	1935		
		12	U10	1935		
		13	U11	1935		
		14	U13	1935		
		15	U14	1936		
		16	U15	1936		
		17	U17	1935		
		18	U18	1936		
		19	U19	1936		
		20	U20	1936		
		21	U21	1936		
		22	U22	1936		
		23	U23	1936		
		24	U24	1936		
IIC	7	25	U56	1938		291/341t, 43.9x4.1x3.8m, 2d/em, 700/410hp, 12/7kts, 22p, 80m; 1x1-20/65, 3-533TT
		26	U57	1938		
		27	U58	1939		
		28	U59	1939		
		29	U60	1939		
		30	U61	1939		
		31	U62	1939		
VIIA	7	32	U28	1936		626/915t, 64.5x5.9x4.4m, 2d/em, 2100-2310/750hp, 16-17/8kts, 44p, 100m; 1x1-88/45, 1x1-20/65, 5-533TT
		33	U29	1936		
		34	U30	1936		
		35	U31	1936		
		36	U32	1936		
		37	U33	1936		
		38	U34	1936		
VIIB	10	39	U46	1938		753/1040t, 66.5x6.2x4.7m, 2d/em, 2800-3200/750hp, 17.2-17.9/8kts, 44p, 100m; 1x1-88/45, 1x1-20/65, 5-533TT
		40	U47	1938		
		41	U48	1939		
		42	U49	1939		
		43	U50	1939		
		44	U51	1938		
45	U52	1939				

			46	U53	1939		
			47	U54	1939		
			48	U55	1939		
IXA	5		49	U37	1938		1032/1153t, 76.5x6.5x4.7m, 2d/em, 4400/1000hp, 18.2/7.7kts, 48p, 100m; 1x1-105/45, 1x1-37/83, 1x1-20/65, 6-533TT
			50	U38	1938		
			51	U41	1939		
			52	U43	1939		
			53	U44	1939		
IXB	1	54	U64	1939		1051/1178t, 76.5x6.8x4.7m, 2d/em, 4400/1000hp, 18.2/7.3kts, 48p, 100m; 1x1-105/45, 1x1-37/83, 1x1-20/65, 6-533TT	
UA	1	55	UA	1939		1128/1357t, 86.7x6.8x4.1m, 2d/em, 4600/1300hp, 18/8.4kts, 45p, 100m; 1x1-105/45, 2x1-20/65, 6-533TT	

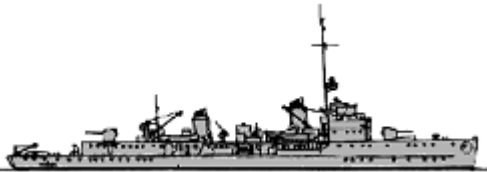
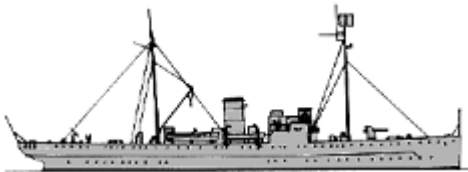
## ESCORTS

FS	F	7	1	F1	1935		1147(1-3)-1028(4-7)t, 80.3(1-3)-76.0(4-7)x8.8x2.6m, 2b,2gt, 14000hp, 21(1-3)-28(4-7)kts, 121p; 2x1-105/45, 2x2-37/83, 4x1-20/65, 4DCR, 62m
			2	F2	1936		
			3	F4	1936		
			4	F5	1936		
			5	F7	1937		
			6	F8	1937		
			7	F10	1938		
PC	Einswarden	1	1	V704	1924	No picture	560t, 39.6x7.1x3.3m, 1b,1vte, 450hp, 10kts, 31p; 1x1-88/45, 1x1-37/83, 2x1-20/65, 2DCR
	Meteor	1	2	Meteor	1924		1504t, 71.1x10.2x3.6m, 2d, 2200hp, 14.5kts, 124p; 1x1-88/45, 2x1-20/65
	Elbe	2	3	Elbe	1931		870t, 58.0x8.5x3.7m, 2d, 1600hp, 14kts, 65p; 1x1-88/45, 1x1-37/83
4			Weser	1931			
			1	V201	1937		465t
			2	V202	1937		481t
			3	V203	1933		391t
			4	V204	1934		437t
			5	V205	1937		481t
			6	V206	1937		510t
			7	V207	1930		389t
			8	V208	1933		391t
			9	V209	1928		391t

10	V210	1934	446t
11	V211	1936	464t
12	V212	1934	437t
13	V215	1930	321t
14	V302	1929	408t
15	V303	1935	464t
16	V304	1925	296t
17	V305	1935	464t
18	V306	1929	391t
19	V307	1929	425t
20	V308	1929	337t
21	V309	1927	391t
22	V401	1938	654t
23	V402	1936	435t
24	V404	1934	444t
25	V405	1934	444t
26	V406	1936	464t
27	V407	1937	481t
28	V408	1934	444t
29	V409	1934	419t
30	V410	1934	429t
31	V411	1934	444t
32	V412	1927	416t
33	V702	1935	449t
34	V703	1924	301t
35	V705	1923	273t
36	V706	1924	279t
37	V707	1924	279t
38	V708	1923	273t
39	V709	1928	291t
40	V801	1930	438t
41	V802	1930	337t
42	V803	1930	321t
43	V804	1930	337t
44	V805	1930	391t
45	V806	1929	301t
46	V807	1930	391t
47	V808	1930	321t
48	V809	1929	408t
49	V810	1929	337t
50	V811	1929	391t



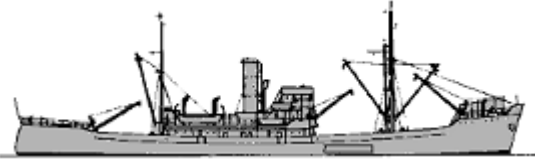

			51	V812	1930		391t
			52	V901	1937		487t
			53	V902	1921		245t
			54	V903	1929		301t
			55	V904	1921		299t
			56	V905	1921		299t
			57	V906	1920		215t
			58	V907	1921		299t
			59	V908	1933		429t
			60	V909	1922		279t
			61	V1001	1938		210t
			62	V1002	1933		196t
			63	V1003	1934		192t
			64	V1004	1933		196t
			65	V1005	1934		196t
			66	V1006	1933		255t
			67	V1007	1934		196t
			68	V1009	1934		196t
			69	V1008	1933		193t
			70	V1010	1933		196t
APC	-	140	71	V1011	1934		192t
			72	V1012	1933		255t
			73	V1101	1930		412t
			74	V1102	1928		340t
			75	V1103	1927		294t
			76	V1104	1928		408t
			77	V1105	1925		286t
			78	V1106	1928		294t
			79	V1107	1928		340t
			80	V1108	1929		337t
			81	V1109	1929		291t
			82	V1201	1938		210t
			83	V1202	1934		194t
			84	V1203	1934		191t
			85	V1204	1933		193t
			86	V1205	1936		212t
			87	V1206	1933		193t
			88	V1207	1934		194t
			89	V1208	1934		191t
			90	V1209	1933		193t

91	V1210	1934	194t
92	V1211	1933	193t
93	V1212	1934	191t
94	V1301	1934	435t
95	V1302	1927	292t
96	V1303	1929	301t
97	V1304	1928	340t
98	V1306	1925	265t
99	V1307	1927	416t
100	V1308	1924	296t
101	V1309	1924	301t
102	V1501	1939	381t
103	V1502	1939	381t
104	V1503	1939	381t
105	V1504	1939	381t
106	V1505	1938	348t
107	V1506	1938	348t
108	V1507	1937	354t
109	V1508	1937	354t
110	V1509	1937	354t
111	V1511	1937	354t
112	V1512	1937	354t
113	G9	1924	305t
114	H201	1938	201t
115	H202	1934	168t
116	H203	1922	120t
117	H204	1933	165t
118	H205	1933	163t
119	H206	1933	163t
120	H242	1933	169t
121	H244	1914	120t
122	H245	1925	127t
123	H2..	1933	165t
124	H305	1892	108t
125	H401	1938	200t
126	H402	1936	177t
127	H403	1934	174t
128	H404	1934	163t
129	H405	1938	203t
130	H408	1933	164t
131	H409	1933	164t

			132	H411	1938		200t
			133	H415	1938		200t
			134	H601	1939		328t
			135	H602	1938		298t
			136	H603	1938		298t
			137	H604	1936		264t
			138	H612	1933		197t
			139	H617	1933		193t
			140	H618	1933		197t
			1	UJ A	1936		330t
			2	UJ B	1936		330t
			3	UJ C	1937		356t
			4	UJ D	1937		356t
			5	UJ G	1936		331t
			6	UJ H	1936		331t
			7	UJ J	1936		331t
			8	UJ K	1936		331t
			9	UJ111	1937		487t
			10	UJ112	1936		464t
			11	UJ113	1939		465t
			12	UJ114	1936		464t
			13	UJ115	1937		481t
			14	UJ116	1936		464t
			15	UJ117	1936		465t
			16	UJ118	1936		465t
			17	UJ121	1939		525t
			18	UJ122	1937		481t
			19	UJ123	1936		464t
			20	UJ124	1938		481t
			21	UJ125	1938		509t
			22	UJ126	1938		446t
			23	UJ127	1938		481t
			24	UJ128	1937		446t
			25	UJ171	1935		209t
			26	UJ173	1938		510t
			27	UJ174	1936		209t
			28	UJ176	1937		487t
			29	UJ177	1938		465t
			30	UJ178	1937		481t
			1	Schiff 4 Coburg	1938		344t

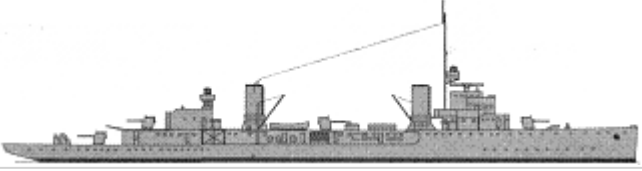
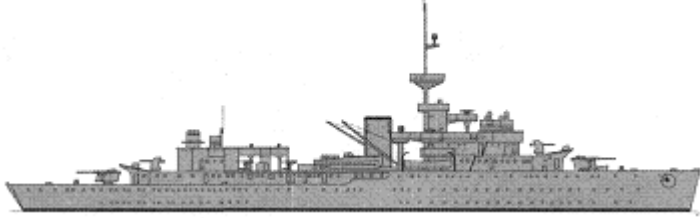
DS	-	12	2	Schiff 4 Wandrahm	1927		2200t, 73.0x11.6x4.4m, 2b,1vte, 750hp, 9.5kts
			3	Schiff 7 Wega	1932		337t; 1x1-88/45, 2-533TT
			4	Schiff 9 Koblenz	1931		438t; 1x1-88/45, 2-533TT
			5	Schiff 15 Neuss	1935		1640t, 73.5x11.0x3.3m, 2d, 900hp, 10.5kts; 2-533TT
			6	Schiff 18 Alteland	1930		419t; 1x1-88/45, 2-533TT
			7	Schiff 20 Nerissa	1936		992t; 2-533TT
			8	Schiff 26 Julius Pickenpack	1931		419t; 1x1-88/45, 2-533TT
			9	Schiff 35 Oldenburg	1936		2312t, 87.8x13.0x6.0m, 2b,1dvc, 1600hp, 12.5kts; 2x1-533TT
			10	Schiff 37 Schleswig	1931		433t; 1x1-88/45, 2-533TT
			11	Schiff 40 Schürbeck	1930		2448t, 93.6x13.9x6.2m, 2b,1dvc, 1225hp; 2x1-533TT
			12	Schiff 47 Wilhelm Huth	1931		438t









## OTHER FIGHTING SHIPS

AG	Bremse	1	1	Bremse (TS)	1932		2054t, 103.6x10.2x2.8m, 8d(2), 26000hp, 27kts, 192p+90; 4x1-128/45, 8x1-20/65, 350m
	Brummer	1	2	Brummer (TS)	1936		3354t, 112.9x13.5x3.2m, 2b,2gt, 10000hp, 20kts, 182p+298; 2x2-105/65, 2x1-88/45, 2x2-37/83, 8x1-20/65, 450m
DV	V180	1	1	Blitz	1910		783t, 73.9x7.9x3.1m, 4b,2t, 18000hp, 32kts, 84p; 2x1-20/65
MONR	Bechelaren	1	1	Bechelaren	1932		230t, 48.5x6.0x1.0m, 2b,2gt, 2300hp, 18kts, 43p; 10belt, 5deck, 8turrets; 2x2-66/35
	Pionier	1	2	Pionier	1934		39t, 23.0x4.0x0.6m, 2d, 450hp, 12.5kts, 16p; 6belt, 12turret; 1x1-40/39, 1x1-37/45

## COASTAL FORCES



	S1	1	1	S1	1939		68t, 28.0x4.5x1.5m, 3d, 2850hp, 37.1kts, 19p; 1x1-20/65, 2-533TT
--	----	---	---	----	------	---	--





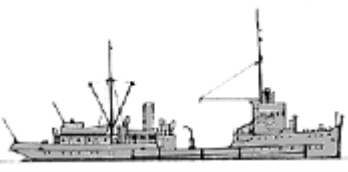
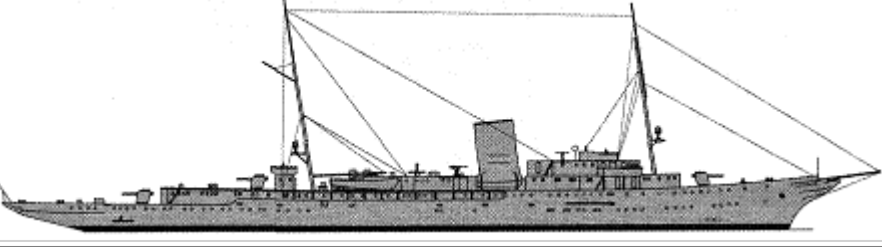

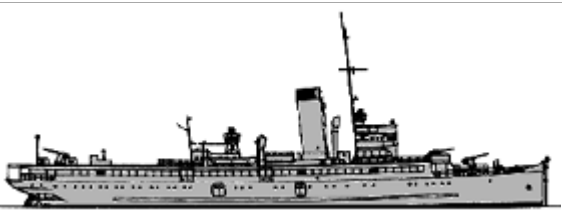
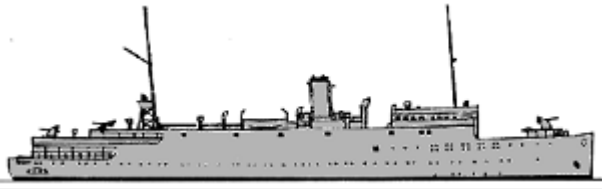
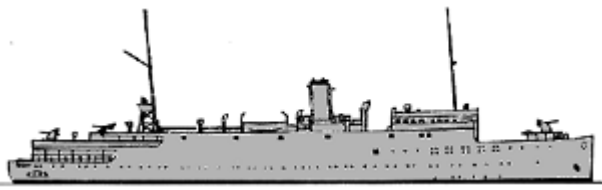
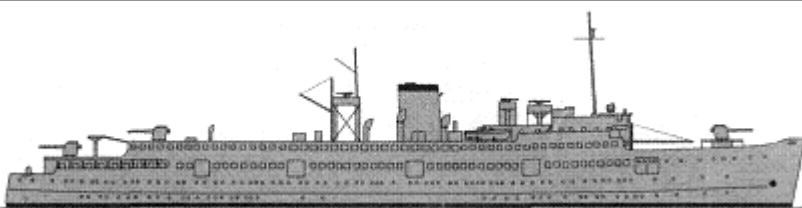
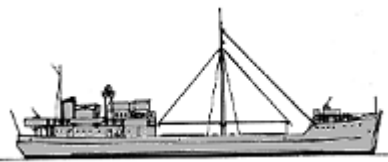

PT	S6	1	2	S6	1933		68t, 32.4x5.1x1.4m, 3d, 3960hp, 32kts, 12p; 1x1-20/65, 2-533TT
	S7	3	3 - 5	S7 - 9	1934 - 1935		86t, 32.4x5.1x1.4m, 3d, 3960hp, 36.5kts, 18p; 1x1-20/65, 2-533TT
	S10	4	6 - 9	S10 - 13	1935		92t, 32.4x5.1x1.4m, 3d, 3960hp, 35kts, 18p; 1x1-20/65, 2-533TT
	S14	3	10	S14	1936		105t, 34.6x5.3x1.7m, 3d, 6150hp, 37.7kts, 18p; 1x1-20/65, 2-533TT
			11	S15	1937		
			12	S16	1937		
	S18	8	13	S18	1938		105t, 34.6x5.3x1.7m, 3d, 6000hp, 39.8kts, 20p; 1x1-20/65, 2-533TT
			14	S19	1938		
			15	S20	1939		
			16	S21	1938		
17			S22	1939			
18			S23	1939			
19			S24	1939			
S30	2	21	S30	1939		100t, 32.8x5.1x1.5m, 3d, 3960hp, 36kts, 24p; 1x1-20/65, 2-533TT, 2DCR	
		22	S31	1939			
PS	UZ1	2	1, 2	H1, 108	1917		53t, 26.0(1)-27.0(2)x4.2(1)-4.0(2)x1.5m, 2pe, 500(1)-420(2)hp, 16.4(1)-15(2)kts, 14p; 1x1-52/55, DCR, MS
	UZ23	1	3	H102	1918		60t, 31.0x4.4x1.3m, 2pe, 570hp, 16kts, 14p; 1x1-52/55, DCR
PR	Spatz	1	1	Panther	1932		17t, 14.0x2.8x0.9m, 1pe, 225hp, 13kts, 4p; 1x1-37/45

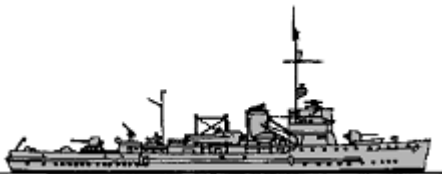
### MINE WARFARE

ML	MW I	2	1	MT1	1917		673t, 53.1x9.3x2.3m, 2b,2vte, 371hp, 9.5kts, 53p; mines
			2	MT2	1917		
	Grille	1	3	Grille	1935		3430t, 142.9x13.5x3.8m, 4b,2gt, 22000hp, 26kts, 257p; 3x1-105/45, 2x2-37/83, 4x1-20/65, 280m
			1	Cobra	1926		2131t, 87.4x12.2x3.0m, 2b,2gt, 3600hp, 17kts; 2x1-88/45, 1x1-37/83, 2x1-20/65, 150m

AML	-	7					
			2	Hansestadt Danzig	1926		2431t, 90.5x11.7x4.5m, 2d, 6400hp, 20kts; 2x1-88/45, 2x1-37/83, 6x1-20/65, 360m
			3	Kaiser	1905		1912t, 96.3x11.7x3.0m, 4b,2gy, 3000hp, 16kts; 2x1-88/45, 1x1-37/83, 8x1-20/65, 200m
			4	Königin Luise	1934		2399t, 93.5x12.8x3.6m, 2d, 4500hp, 17kts; 2x1-88/45, 1x1-37/83, 2x1-20/65, 240m
			5	Preussen	1926		2529t, 93.6x11.7xm, 2d, 6400hp, 16kts; 2x1-88/45, 400m
			6	Roland	1927		2436t, 90.8x13.0x3.4m, 2b,2gt, 4850hp, 18kts; 2x1-88/45, 1x1-37/83, 2x1-20/65, 233m
			7	Tannenberg	1935		5504t, 129.6x15.5x7.6m, 2b,2gt, 12000hp, 20kts; 3x1-105/45, 4x1-37/83, 6x1-20/65, 460m
MT	Lauting	4	1	Lauting	1934		1158-1253t, 56.7x10.4x4.4m, 1d, 450hp, 9.5kts, 43p; 4x1-20/65, 370m(1-3), 240m(4)
			2	Rhein	1934		
			3	Otter	1934		
			4	Irben	1936		
MLBR	FM	2	1,2	FM1,2	1938-1939		76t, 32.0x4.0x1.0m, 2d, 900hp, 18.2kts, 18p; 2x1-15, 22m
1916	16	1	M72	1918		535-590t, 58.2-59.5x7.3-7.4x2.2-2.3m, 2b,2vte, 1600-1870hp, 15-16.5kts, 40p; 2x1-88/45(1,4), 2x1-105/45(5-16), 3x1-88/45(2,3)	
		2	M75	1917			
		3	M84	1917			
		4	M89	1918			
		5	M98	1918			
		6	M102	1918			
		7	M104	1918			
		8	Delphin (TS)	1918			
		9	M110	1918			

MS							
		10	M111	1918			
		11	M117	1919			
		12	M126	1919			
		13	Fuchs (TS)	1919			
	14	M145	1919				
	15	M146	1919				
	16	M157	1919				
	1935	15	17	M1	1938		
			18	M2	1939		
			19	M3	1938		
			20	M4	1938		
			21	M5	1939		
			22	M6	1939		
			23	M7	1938		
			24	M8	1939		
			25	M9	1939		
			26	M10	1939		
			27	M11	1939		
			28	M12	1939		
			29	M13	1939		
			30	M14	1939		
	31	M20	1939				
	F	3	1 - 3	H106, 107, R113	1915		21t, 16.5-17.5x4.0x1.1m, 2pe, 120-130hp, 10-11kts, 7p; MS
	R1	1	4	R1	1931		43t, 24.5x4.4x1.2m, 2d, 700hp, 17kts, 15p; 1x1-20/65, MS
	R2	14	5 - 18	R2 - 7, 9 - 16	1932 - 1934		44-53t, 24.5-27.8x4.4x1.3-1.5m, 2d, 700-770hp, 16.5-20kts, 15-18p; 1x1-20/65, MS
	R8	1	19	R8	1934		63t, 27.8x4.5x1.1m, 2d, 750hp, 16.5kts, 18p; 1x1-20/65, MS
	R17	8	20	R17	1935		120-124t, 36.9-37.0x5.4-5.8x1.3-1.4m, 2d, 1800-2200hp, 21kts, 16-21p; 2x1-20/65, 12m, MS
			21	R18	1935		
22			R19	1935			
23			R20	1935			
24			R21	1937			
25			R22	1937			
26			R23	1938			
27	R24	1937					

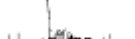
MSB	R25	16	28	R25	1938		126t, 35.4x5.6x1.4m, 2d, 1800hp, 23.5kts, 20p; 2x1-20/65, 10m, MS
			29	R26	1938		
			30	R27	1938		
			31	R28	1938		
			32	R29	1938		
			33	R30	1938		
			34	R31	1938		
			35	R32	1938		
			36	R33	1939		
			37	R34	1939		
			38	R35	1939		
			39	R36	1939		
			40	R37	1939		
			41	R38	1939		
			42	R39	1939		
			43	R40	1939		
KR	3	44 - 46	KR1 - 3	1938		11-13t, 13.5x3.4-3.5x0.9m,, 2d, 150-170hp, 10-12kts, 6-8p; MS	
FR	12	47 - 58	FR1 - 12	1938 - 1939		21-27t, 15.4-17.4x3.3x0.8-0.9m, 2d, 260-300hp, 13kts, 9-10p; 1x1-20/65, MS	
FHR	5	59 - 63	FHR2 - 6	1938		14t, 15.0x3.0x0.9m, 1d, 100hp, 13kts, 6p; MS	
			1	M1101	1938		518t
			2	M1102	1937		465t
			3	M1103	1937		465t
			4	M1104	1937		465t
			5	M1105	1937		465t
			6	M1106	1937		481t
			7	M1107	1937		446t
			8	M1108	1937		487t
			9	M1201	1939		515t
			10	M1202	1937		481t
			11	M1203	1936		500t
			12	M1204	1937		481t
			13	M1205	1937		481t
			14	M1206	1936		446t
			15	M1207	1936		429t
			16	M1208	1937		435t
			17	M1301	1938		533t
			18	M1302	1937		446t
			19	M1303	1938		518t

AMS - 67

20	M1304	1936		446t
21	M1305	1938		518t
22	M1306	1936		449t
23	M1307	1938		538t
24	M1308	1938		485t
25	M1401	1939		298t
26	M1402	1937		264t
27	M1403	1937		264t
28	M1404	1936		264t
29	M1405	1937		264t
30	M1407	1939		353t
31	M1408	1935		242t
32	M1502	1938		446t
33	M1503	1938		509t
34	M1504	1938		446t
35	M1505	1937		446t
36	M1506	1937		481t
37	M1507	1937		487t
38	M1508	1937		481t
39	M1601	1939		654t
40	M1602	1939		497t
41	M1603	1937		487t
42	M1604	1937		481t
43	M1605	1936		446t
44	M1606	1938		654t
45	M1607	1939		525t
46	M1608	1936		435t
47	M1701	1938		525t
48	M1702	1938		481t
49	M1704	1938		481t
50	M1705	1938		481t
51	M1706	1938		481t
52	M1707	1938		481t
53	M1708	1938		435t
54	M1801	1939		654t
55	M1802	1939		497t
56	M1803	1939		353t
57	M1806	1937		481t
58	M1807	1938		481t
59	M1808	1934		449t
60	M1901	1937		481t

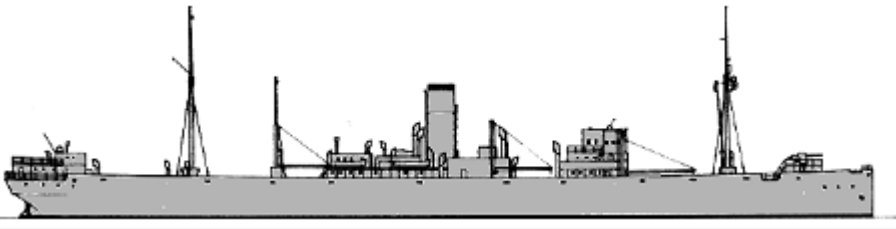
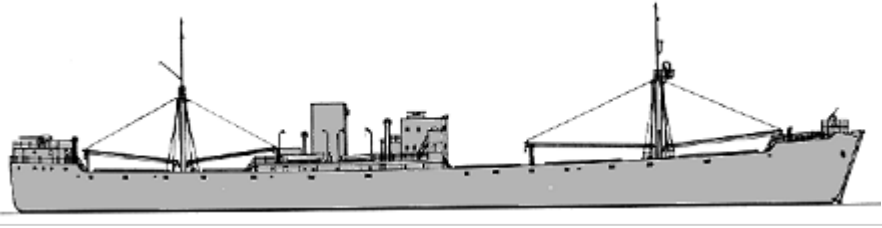
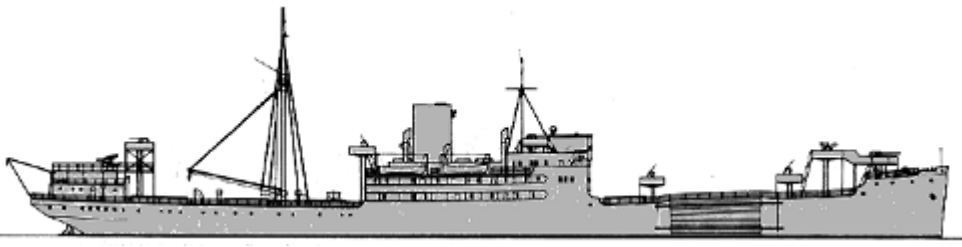
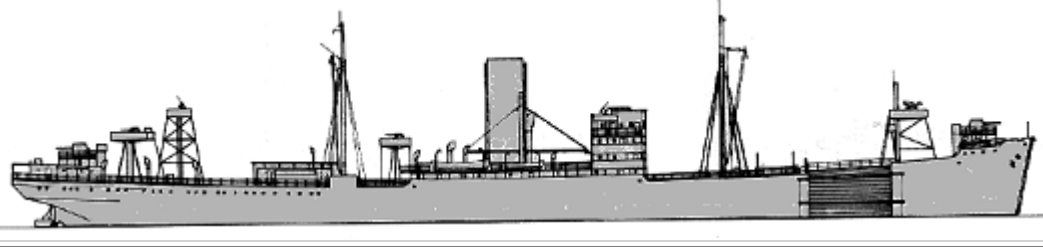
	61	M1902	1928		291t
	62	M1903	1937		435t
	63	M1904	1935		446t
	64	M1906	1937		481t
	65	M1907	1937		481t
	66	M1905	1938		481t
	67	M1908	1937		481t
	1	Bochum	1921		11300t, 137.2x17.8x7.7m, 4b,1vte/et, 5400hp, 13kts
	2	Buenos Aires	1912		13850t, 155.5x18.0x8.2m, 4b,2vte, 4300hp, 12.5kts
	3	Muansa	1911		10000t, 132.6x16.5x7.9m, 4b,1vqe, 3300hp, 11.5kts
	4	Sperrbrecher I	1918		8551brt, 136.6x17.4x8.5m, 4b,1vte, 3250hp, 11kts; 1x1-105/45, 2x1-20/65
	5	Sperrbrecher II	1913		6042brt, 126.3x16.9x7.5m, 3b,1vte, 1700hp, 10kts; 1x1-105/45, 2x1-20/65
	6	Sperrbrecher III	1918		6643brt, 125.6x16.9x7.8m, 3b,1vte, 2500hp, 11kts; 1x1-105/45, 2x1-20/65
	7	Sperrbrecher IV	1929		6757brt, 137.5x18.0x7.9m, 1d, 4500hp, 13kts; 2x1-105/45, 2x1-37/83, 3x1-20/65
	8	Speerbrecher V	1935		5339brt, 137.7x16.9x7.7m, 1d, 3250hp, 13kts; 2x1-105/45, 2x1-37/83, 12x1-20/65
AMDV -	15	9	Sperrbrecher VI	1925	6128brt, 136.5x17.7x7.8m, 1d, 4000hp, 13kts; 2x1-105/45, 4x1-37/83, 10x1-20/65
	10	Sperrbrecher VII	1929		7087brt(13100t), 148.2x18.6x7.9m, 1d, 5000hp, 12kts; 2x1-105/45, 2x1-37/83, 12x1-20/65
	11	Sperrbrecher VIII	1927		8417brt, 162.3x19.4x8.6m, 5b,1vte, 6500hp, 14kts; 2x1-105/45, 4x1-37/83, 8x1-20/65
		Sperrbrecher			5828brt, 137.5x17.4x8.2m, 4b,1vte, 4675hp, 13kts; 2x1-105/45, 4x1-

		12	IX	1914		37/83, 8x1-20/65
		13	Sperrbrecher X	1922		7358brt, 126.0x18.3x8.3m, 3b,1vte, 3800hp, 12kts; 2x1-105/45, 4x1-37/83, 5x1-20/65, 1balloon
		14	Sperrbrecher XI	1911		4845brt, 127.4x16.4x8.4m, 3b,1vte, 3000hp, 12kts; 1x1-105/45, 2x1-20/65
		15	Sperrbrecher XII	1915		7512brt, 142.8x17.8x8.3m, 4b,1vte, 4500hp, 12kts; 1x1-105/45, 2x1-20/65

NAVAL AVIATION (*approximately, maximal number of delivered planes signed*)

Deck planes	F: 10 Bf 109T; B: 10 Ju 87C
Seaplanes	R: 200 He 60B, C, D, 43 He 114A, 20 Ar 196A; P: 75 Do 18D, 70 Do 18G ( <i>delivery till 8/1940</i> )

[home](#)

[World navies yesterday](#)



[1940](#)

# Greece 01 January 1940

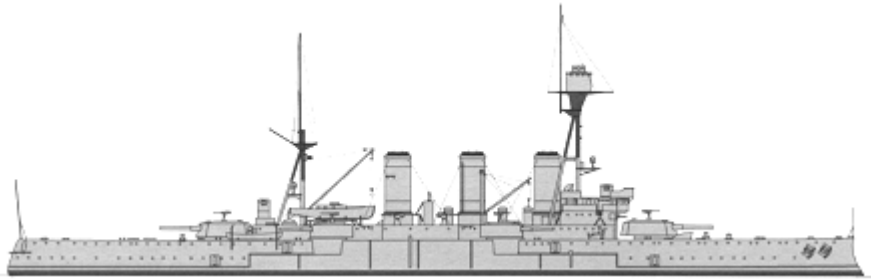
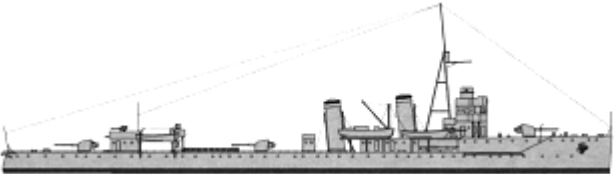

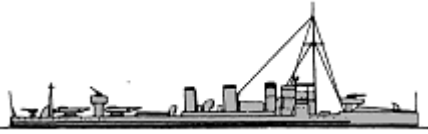
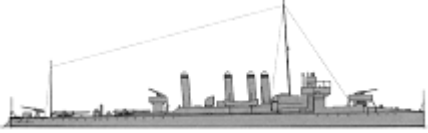

## CRUISERS

CA	Averof	1	1	Averof	1911		10200t, 140.8x21.0x7.5m, 22b,2vte, 19000hp, 22.5kts, 670p; 200belt, 50deck, 140turrets, 180CT; 2x2-234/45, 4x2-190/45, 12x1-76/40, 6x1-20/65
CL	Elli	1	1	Elli	1913		2750t, 98.1x11.9x4.3m, 3b,3t, 7500hp, 20.5kts, 232p; 51slopes, 51deck, 50CT; 3x1-152/50, 2x1-76/40, 2x1-40/39, 2x1-450TT, 110m

## TORPEDO SHIPS

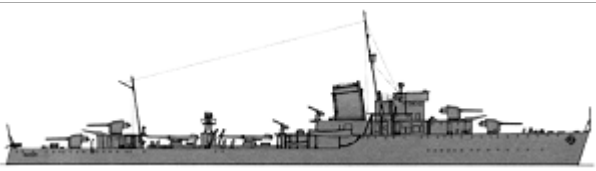
DD	Niki	1	Niki	1906		350t, 67.0x6.6x2.7m, 4b,2vte, 6800hp, 30kts, 58p; 2x1-88/30, 1x1-40/39, 2x1-450TT
		2	Aspis	1906		
DD	Thyella	3	Thyella	1907		380t, 67.1x6.2x1.8m, 4b,2vte, 6000hp, 30kts, 70p; 2x1-88/30, 1x1-40/39, 2x1-450TT
		4	Sfendoni	1907		
DD	Aetos	5	Aetos	1912		1300t, 89.3x8.5x2.6m, 4b,2t, 19750hp, 32kts, 110p; 4x1-102/50, 4x1-40/39, 2x3-533TT, 40m(5,8)
		6	Ierax	1912		
		7	Leon	1912		
		8	Panthir	1912		
DD		9	Kountouriotis	1932		



TB	Hydra	4	10	Hydra	1932		2050t, 94.3x9.8x3.3m, 3b,2gt, 44000hp, 38kts, 156p; 4x1-120/50, 3x1-40/39, 2x3-533TT, 40m(9,10)
			11	Psara	1933		
			12	Spetsai	1933		
	Vasilefs Georgios I	2	13	Vasilefs Georgios I	1938		1850t, 98.5x10.2x2.6m, 3b,2gt, 34000hp, 36kts, 162p; 4x1-128/45, 4x1-37/83, 2x4-12.7, 2x4-533TT, 2DCT, 1DCR
			14	Vasilissa Olga	1939		
	TB	Aigli	4	1	Aigli	1912	
2				Alkyoni	1914		
3				Arethousa	1913		
4				Doris	1913		
Panormos		2	5	Proussa	1916		330t, 58.8x5.8x1.5m, 2b,2t, 5000hp, 28kts, 38p; 1x1-66/30, 1x1-37/83, 2x1-533TT, 12m
			6	Pergamos	1916		
Kyzikos		3	7	Kyzikos	1915		330t, 60.5x5.6x1.6m, 2b,2t, 5000hp, 28.5kts, 38p; 1x1-66/30, 1x1-37/83, 2x1-533TT, 12m
			8	Kios	1915		
			9	Kidoniai	1916		

## SUBMARINES

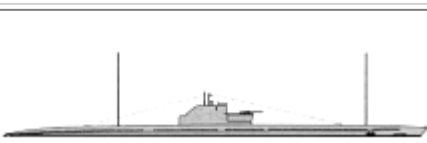
SS	Katsonis	2	1	Katsonis	1928		576/775t, 62.5x5.3x3.4m, 2d/em, 1200/1000hp, 14/9.5kts, 39p, 80m; 1x1-100/40, 1x1-40/39, 6-533TT
			2	Papanikolis	1927		
	Glafkos	4	3	Protefs	1929		790/960t, 68.6ppx5.7x4.2m, 2d/em, 1420/1200hp, 14/9.5kts, 41p, 85m; 1x1-100/40, 1x1-40/39, 8-533TT
			4	Nirefs	1930		
			5	Triton	1930		
			6	Glafkos	1930		

## COASTAL FORCES

PT	2	2	1, 2	T1, 2	1929		15t, 16.8x3.4x1.0m, 2pe, 750hp, 40.4kts, 5p; 2-450TR, 1DCR
YP	A1	6	1-6	A1-6	1926-1927	No picture	58t, 13.0xxm; 1x1-76/40, 1DCR
	A32	1	7	A32	1930	No picture	

## MINE WARFARE SHIPS

ML	Pleias	1	1	Pleias	1928		520t, 49.4x8.2x3.8m, 1vte, 1000hp, 14kts; 50m
	Kichli	1	2	Kichli	1884	No picture	86t, 24.2x4.9x2.1m, 1vc, 162hp, 10kts; 10m

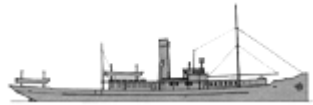



AML	-	3	1	Korgialenios	1916		380t; 50m
			2	Tenedos	1906		450t; 40m
			3	Paralos	1925		395t; 52m
AMS	-	4	1	Aliakmon	1926		500t
			2	Axios	1926		500t
			3	Nestos	1926		500t
			4	Strymon	1926		500t

© Ivan Gogin, 2011-14



[home](#)[World navies yesterday](#)[1940](#)

# Hungary 01 January 1940

## RIVER BOATS

PGR	Compo	1	Szeged	1916		133t, 44.0x6.0x1.0m, 2b,2gt, 1200hp, 15kts, 40p; 8belt, 6deck, 10turrets, 10CT; 2x1-77/30(1-3), 2x1-75/60(4), 1x1-50/12(4)	
		2	Kecskemét	1916			
		3	Baja	1916			
		4	Győr	1916			
	Komarom	2	5	Debreczen	1918		160t, 45.5x6.0x1.0m, 2b,2gt(5)-2d(6), 1400(5)-1600(6)hp, 16kts, 42p; 10belt, 6deck, 22turrets, 10CT; 2x1-84/33
		6	Sopron	1918			
YPAR	Hüszar	3	1-3	Honved, Hüszar, Tüzér	1916		18(1)-15(2,3)t, 15.2(1)-16.0(2,3)x3.1(1)-2.8(2,3)x0.7(1)-0.6(2,3)m, 2pe, 140hp, 13.5kts, 9p; 7belt, 5deck, 7turret, 7CT
	Siofok	1	4	Gödöllő	1916		60t, 36.0x4.6x0.9m, 2b,2vte, 800hp, 12kts, 27p; 5belt, 4deck, 5turret, 5CT; 1x1-66/30

## MINE WARFARE SHIPS

MLR	Körös	1	1	Körös	1918		193t, 43.0x6.0x1.4m, 1b,2vte, 600hp, 14kts, 35p; 20m
MLBR	Maros	1	1	Maros	1928		90t, 30.0x5.0x0.8m, 1d, 280hp, 11kts, 9p; 12m or MS

[home](#)

[World navies yesterday](#)

[1940](#)

## Iceland 01 January 1940

### ESCORTS

APC	-	4	1	Sudin	1895	811brt
			2	Thor	1922	226brt
			3	Ægir	1929	507brt
			4	Esja	1939	1347brt

© Ivan Gogin, 2011-15

[home](#)[World navies yesterday](#)[1940](#)

# INDIA 01 January 1940

## ESCORTS

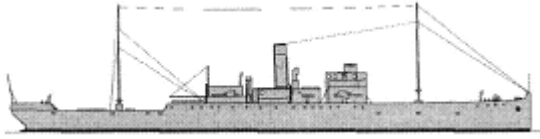
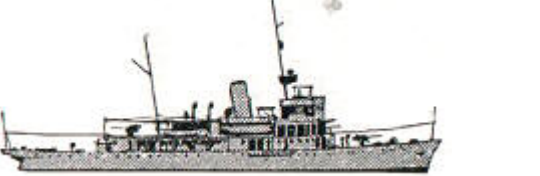
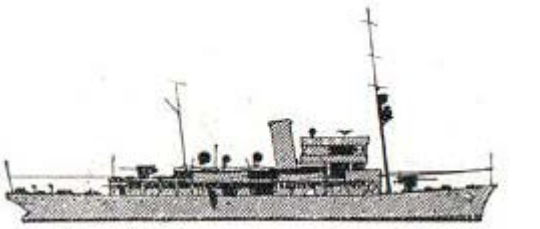
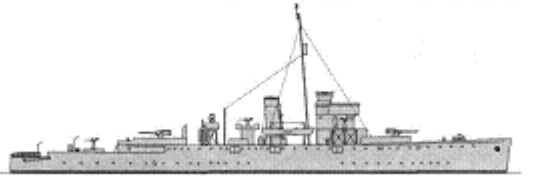
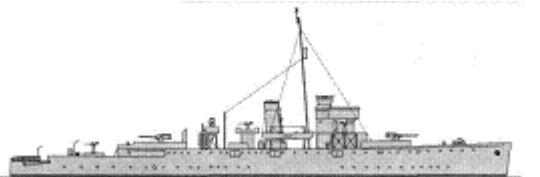
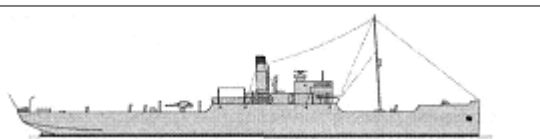
SL	Aubretia	1	1	Cornwallis	1917		1450t, 81.7x10.2x3.4m, 2b, 1vte, 2500hp, 17.5kts, 92p; 2x1-102/40, 2x1-40/39, 2DCT, 1DCR
	Lawrence	1	2	Lawrence	1919		1412t, 69.6x10.4x3.6m, 2b, 2t, 1900hp, 15kts, 119p; 2x1-102/40, 2x1-47/40, 2x1-40/39
	Clive	1	3	Clive	1920		2021t, 80.0x11.7x4.3m, 2b, 2t, 2000hp, 14.5kts, 123p; 2x1-102/40, 2x1-47/40, 2x1-40/39
	Hindustan	1	4	Hindustan	1930		1500t, 90.3x10.7x3.3m, 2b, 2gt, 2000hp, 16.2kts, 119p; 2x1-102/40, 1x4-12.7/62, 2DCT, 1DCR, MS
	Indus	1	5	Indus	1935		1500t, 90.3x10.8x3.3m, 2b, 2gt, 2000hp, 16.2kts, 119p; 2x1-120/45, 4x1-47/40, 2DCT, 1DCR, MS
FS	PC-boat	1	1	Pathan	1918		780t, 75.3x7.8(4)-8.2(5-7)x2.4m, 2b, 2t, 3500hp, 20kts, 55p; 1x1-102/40, 2x1-76/40, 2x1-356TT, 2DCR

APC -	29	1	Bhadravati	1932		1449brt, 70.3x11.8xm, 1vte, 12kts
		2	Haideri	1920		1510brt, 72.2x10.3xm, 1vte, 9kts
		3	Irrawadi	1913		1243brt, 68.6x10.4xm, 1vte, 11kts
		4	Kalavati	1928		1408brt, 70.3x11.8xm, 1vte, 12kts
		5	Netravati	1909		1540brt, 75.2x11.0xm, 1vte, 13kts
		6	Parvati	1927		1548brt, 76.2x11.6xm, 1vte, 13.5kts
		7	Sonavati	1935		1638brt, 77.8x12.9xm, 1d, 14kts
		8	Sophie Marie	1923		1138brt, 69.0x10.5xm, 1vte, 10kts
		9	Victoria-Marie	1926		1432brt, 72.1x11.6xm, 1vte, 11kts
		10	Badora	1914		279brt
		11	Chandbali	1919		362brt
		12	Chandravati	1933		556brt
		13	Dipavati	1936		840brt
		14	Hashemi	1918		634brt
		15	Hiravati	1930		580brt
		16	Kutubtari	1915		237brt
		17	Lady Craddock	?		?
		18	Lady Slater	1934		273brt
		19	Liavati	1911		293brt
		20	Nulchira	1908		272brt
		21	Oostcappelle	1921		751brt
		22	Padmavati	1904		252brt
		23	Prabnavati	1933		566brt
		24	Ramdas	1935		406brt
		25	Ratnagiri	1935		590brt
		26	St. Anthony	1936		452brt
		27	Sandip	1915		285brt
		28	Selama	1914		291brt
		29	Sitakhoond	1910		280brt

## MINE WARFARE

AMS	-	1	1	Satyavati	1911	295t
-----	---	---	---	-----------	------	------

[home](#)[World navies yesterday](#)[1940](#)

## Iran 01 January 1940

### ESCORTS

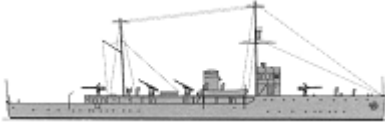
SL	Babr	2	1	Babr	1932		1100t, 62.4ppx9.0x3.0m, 2d, 1900hp, 15kts, 85p; 2x1-102/35, 2x1-76/40, 80m
			2	Palang	1932		
PC	Shahrokh	4	1	Shahrokh	1932	No picture	360t, 51.8ppx6.7x1.8m, 2d, 900hp, 15.5kts; 2x1-76/40, 2x1-37/32
			2	Shahbaz	1932		
			3	Karkass	1932		
			4	Simurgh	1932		

### OTHER FIGHTING SHIPS

PG	Fathiya	1	1	Shahin	1919		193t, 43.0x6.0x1.4m, 1b,2vte, 600hp, 14kts, 35p; 1x1-76/40
----	---------	---	---	--------	------	--	--

### COASTAL FORCES

YP	Azerbaijan	3	1-3	Azerbaijan, Gilani, Mazandaran	1933	No picture	32t, 20.9x3.8x1.1m, 2d, 300hp, 14kts, 15p; 1x1-47/44
----	------------	---	-----	--------------------------------	------	------------	--

[home](#)

[World navies yesterday](#)

[1940](#)

# Iraq 01 January 1940

## COASTAL FORCES

YPR	No1	4	1-4	No1-4	1937	No picture	67t, 30.5x5.2x0.9m, 2d, 280hp, 12kts; 1x1-94/12how, 2x1-81/12mor
-----	-----	---	-----	-------	------	------------	--

© Ivan Gogin, 2011-15



[home](#)

[World navies yesterday](#)

[1940](#)

## Ireland 01 January 1940

### ESCORTS

APC	-	2	1	Muirchú	1908		323brt; 1x1-76/40
			2	Fort Rannoch	1936		258brt; 1x1-76/40

© Ivan Gogin, 2011-15

[home](#)

[World navies yesterday](#)

[1940](#)

# ITALY 01 January 1940

## CAPITAL SHIPS

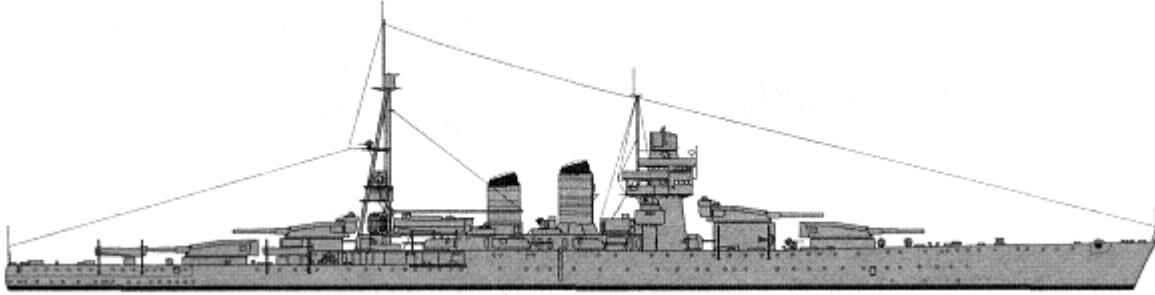
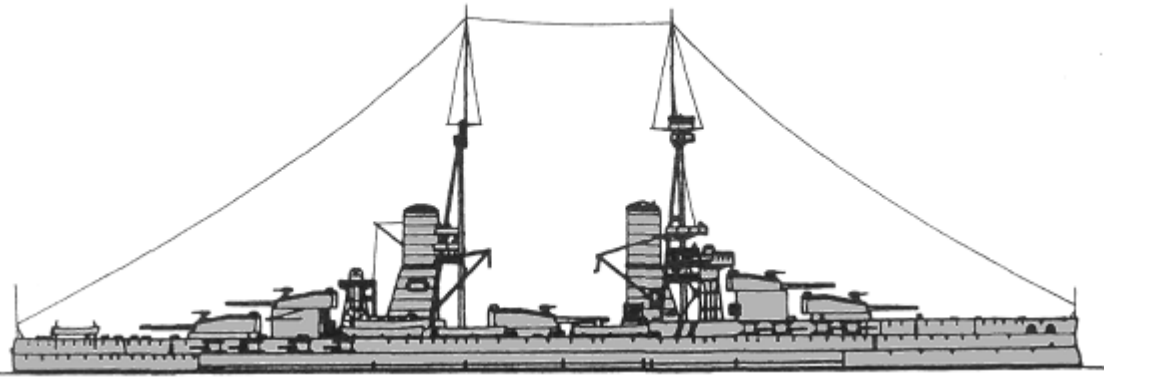
	Giulio Cesare	1	Giulio Cesare	1914		29100(1)-29032(2)t, 186.4x28.6x9.2m, 8b,2gt, 93000hp, 28kts, 1236p; 250belt, 44+100deck, 280turrets, 260CT; (2x3+2x2)-320/44, 6x2-120/50, 4x2-100/47, 6x2-37/54, 6x2-13.2
		2	Conte di Cavour	1915		
BB	Duilio	3	Caio Duilio	1915		24715(3)-24279(4)t, 176.1x28.0x8.9m, 20b,4gt, 30000hp, 21kts, 1232p; 250belt, 44+30+24/40deck, 280turrets, 280CT; (3x3+2x2)-305/46, 16x1-152/45, 25x1-76/50, 2x1-40/39, 1seaplane (P.6), 3-450TT
		4	Andrea Doria	1916		

## AIRCRAFT CARRYING SHIPS

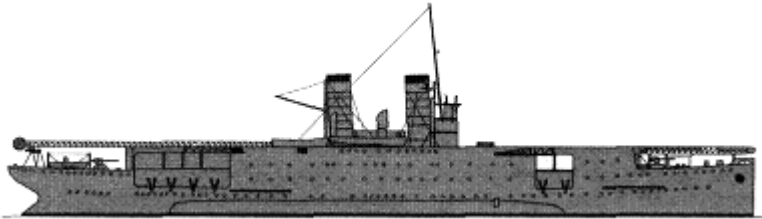
AV	Giuseppe Miraglia	1	Giuseppe Miraglia	1927		5913t, 121.2x15.0x5.2m, 8b,2gt, 12000hp, 21kts, 196p; 4x1-102/35, 20seaplanes (Ro.43, Ro.44)
----	-------------------	---	-------------------	------	--	--



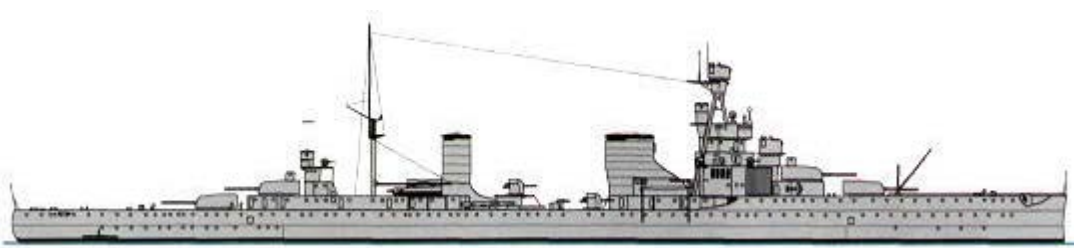
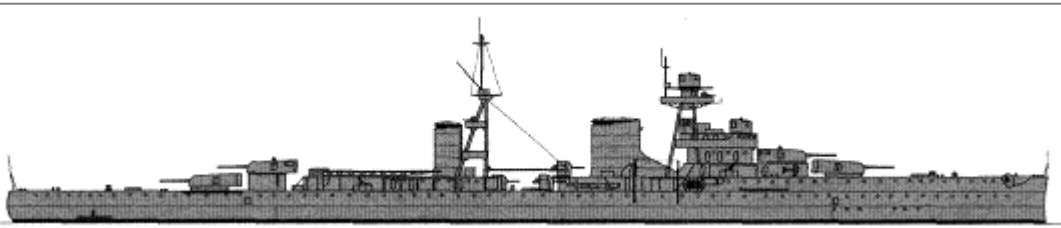
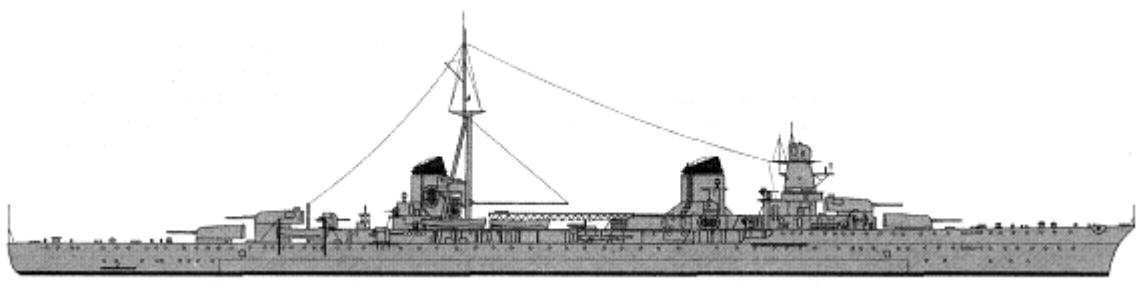
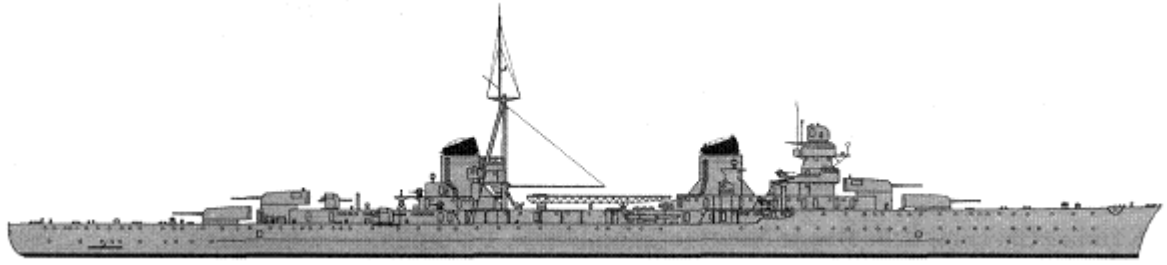
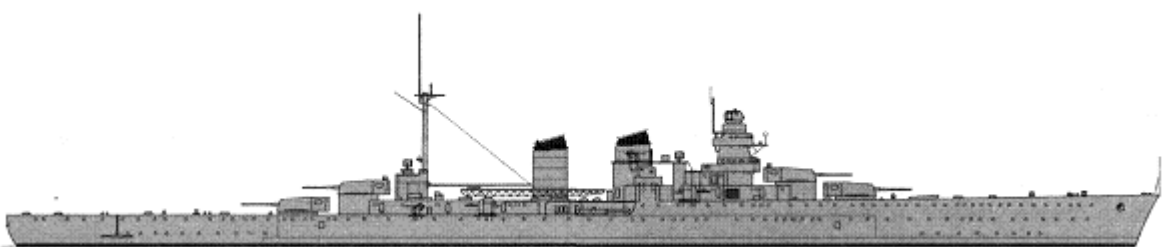

## CRUISERS



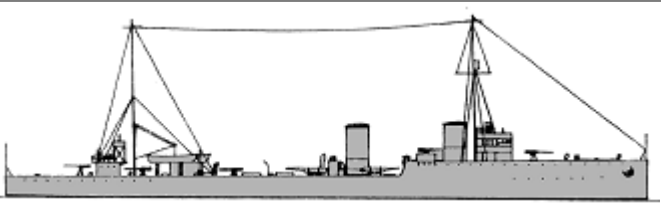

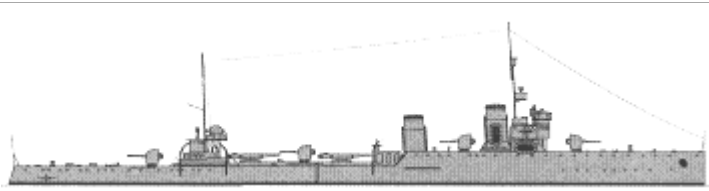
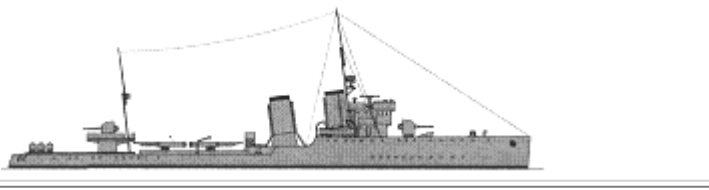
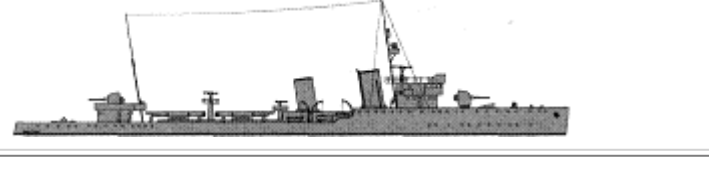
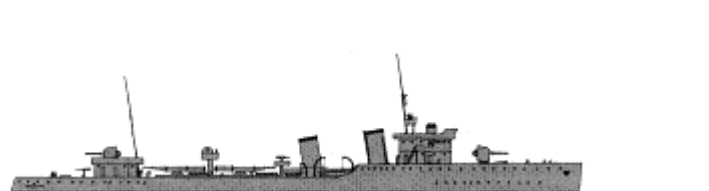
CA	San Giorgio	1	1	San Giorgio	1910		11500t, 140.8x21.0x7.3m, 8b, 2vte, 18200hp, 18.6kts, 705p; 200belt, 50deck, 200turrets, 250CT; 2x2-254/45, 4x2-190/45, 4x2-100/47, 2x2-13.2
	Trento	2	2	Trento	1929		13334(2)-13326(3)t, 197.0x20.6x6.8m, 12b,4gt, 15000hp, 36kts, 781p; 70belt, 50deck, 80turrets, 100CT; 4x2-203/50, 6x2-100/47, 4x2-37/54, 4x2-13.2, 8-533TT, 3seaplanes (Ro.43)
			3	Trieste	1928		
	Zara	4	4	Zara	1931		14300(4)-13944(5)-14330(6)-14133(7)t, 182.8x20.6x7.2m, 8b,2gt, 95000hp, 32kts, 841p; 150belt, 70deck, 150turrets, 150CT; 4x2-203/53, 6x2-100/47, 4x2-37/54, 4x2-13.2, 3seaplanes (Ro.43)
			5	Fiume	1931		
			6	Gorizia	1932		
			7	Pola	1932		
	Bolzano	1	8	Bolzano	1933		13665t, 196.9x20.6x6.8m, 10b,4gt, 15000hp, 36kts, 725p; 70belt, 50deck, 80turrets, 100CT; 4x2-203/53, 6x2-100/47, 4x2-37/54, 4x2-13.2, 8-533TT, 3seaplanes (Ro.43)
	Taranto	1	1	Taranto	1912		5281t, 138.7x13.5x5.1m, 16b,2t, 13000hp, 21kts, 486p; 60belt, 40/60deck, 50shields, 100CT; 7x1-150/43, 2x1-76/40, 2x2-13.2, 120m, 1seaplane (Ro.43)
	Bari	1	2	Bari	1914		5220t, 135.3x13.6x6.0m, 4b,2t, 21000hp, 24.5kts, 440p; 80deck, 50shields, 75CT; 8x1-150/43, 3x1-76/40, 3x2-20/65, 3x2-13.2, 120m
			Alberico da				



CL	Condottieri-1	3	Barbiano	1931		6844t, 169.3x15.5x5.3m, 6b,2gt, 95000hp, 36.5kts, 520p; 24+18belt, 20deck, 23turrets, 40CT; 4x2-152/53, 3x2-100/47, 4x2-20/65, 4x2-13.2, 2x2-533TT, 2DCT, 138m (3,5,6), 2seaplanes (Ro.43)
		4	Alberto di Giussano	1931		
		5	Bartolomeo Colleoni	1932		
		6	Giovanni delle Bande Nere	1931		
	Condottieri-2	7	Luigi Cadorna	1933		7001(7)-7080(8)t, 169.3x15.5x5.5m, 6b,2gt, 95000hp, 36.5kts, 544p; 24+18belt, 20deck, 40turrets, 70CT; 4x2-152/53, 3x2-100/47, 4x2-20/65, 4x2-13.2, 2x2-533TT, 2DCT, 2seaplanes (Ro.43), 138m
		8	Armando Diaz	1933		
	Condottieri-3	9	Raimondo Montecuccoli	1935		8853(9)-8848(10)t, 182.2x16.6x6.0m, 6b,2gt, 106000hp, 37kts, 650p; 60+25belt, 30deck, 70turrets, 100CT; 4x2-152/53, 3x2-100/47, 4x2-37/54, 4x2-13.2, 2x2-533TT, 2seaplanes (Ro.43), 2DCT, 146m
		10	Muzio Attendolo	1935		
	Condottieri-4	11	Emanuele Filiberto Duca d'Aosta	1935		10374(11)-10672(12)t, 186.9x17.5x6.5m, 6b,2gt, 110000hp, 36.5kts, 694p; 70+35belt, 35deck, 90turrets, 100CT; 4x2-152/53, 3x2-100/47, 4x2-37/54, 6x2-13.2, 2x3-533TT, 2seaplanes (Ro.43), 2DCT, 146m
		12	Eugenio di Savoia	1936		
	Condottieri-5	13	Luigi di Savoia Duca degli Abruzzi	1937		11575(13)-11117(14)t, 187.0x18.9x6.8m, 8b,2gt, 100000hp, 34kts, 692p; 100+30belt, 40+15deck, 135turrets, 140CT; (2x3+2x2)-152/55, 4x2-100/47, 4x2-37/54, 4x2-13.2, 2x3-533TT, 4seaplanes (Ro.43), 2DCT, 120m
		14	Giuseppe Garibaldi	1937		

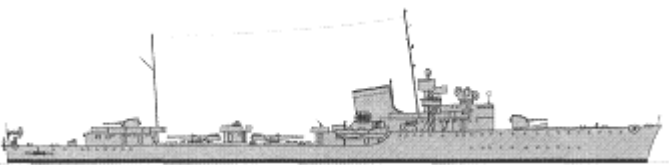
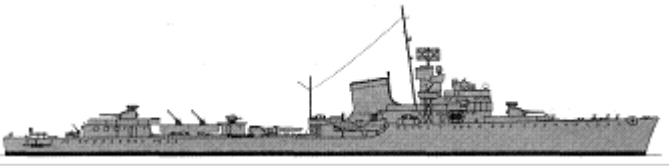

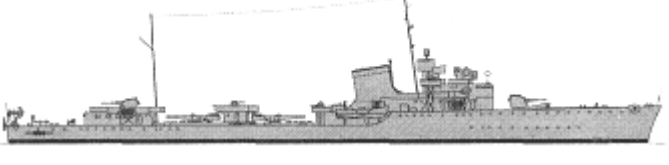
## TORPEDO SHIPS

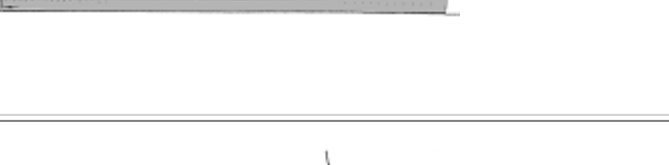
Mirabello	2	1	Carlo Mirabello	1916		1972t, 103.4x9.7x3.3m, 4b,2t, 44000hp, 35kts, 169p; 8x1-102/45, 2x1-40/39, 2x2-450TT, 100m(1), 120m(2)
		2	Augusto Riboty	1917		
	3	3	Leone	1924		
		4	Pantera	1924		

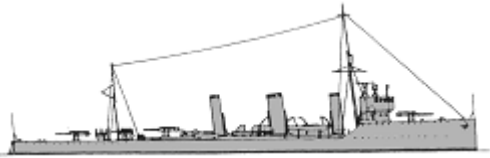
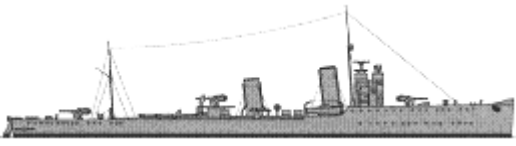
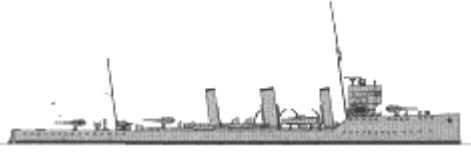
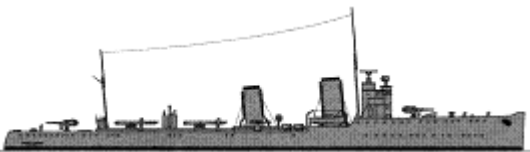

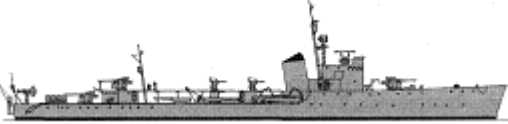
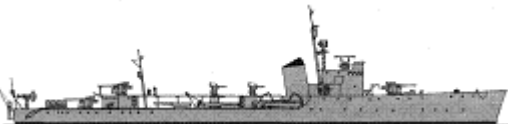
DD	Leone	3				2650t, 113.4x10.3x3.2m, 4b,2t, 42000hp, 34kts, 206p; 4x2-120/45, 2x1-40/39, 2x2-20/65, 2x2-533TT, 60m	
			5	Tigre			1924
	Sella	4	6	Francesco Crispi	1927		1457t, 84.9x8.6x2.7m, 3b,2gt, 36000hp, 35kts, 152p; 2x2-120/45, 2x1-40/39, 2x2-13.2, 2x2-533TT, 2DCT, 32m
			7	Quintino Sella	1926		
			8	Bettino Ricasoli	1926		
			9	Giovanni Nicotera	1927		
	Sauro	4	10	Cesare Battisti	1927		1575t, 90.2x9.2x2.9m, 3b,2gt, 36000hp, 35kts, 155p; 2x2-120/45, 2x1-40/39, 2x1-13.2, 2x3-533TT, 2DCT, 52m
			11	Daniele Manin	1927		
			12	Francesco Nullo	1927		
			13	Nazario Sauro	1926		
	Turbine	8	14	Aquilone	1927		1670t, 93.2x9.2x3.0m, 3b,2gt, 40000hp, 36kts, 179p; 2x2-120/45, 2x1-40/39, 1x2-13.2, 2x3-533TT, 52m
			15	Borea	1927		
			16	Espero	1928		
			17	Euro	1927		
			18	Nembo	1927		
			19	Ostro	1928		
			20	Turbine	1927		
			21	Zeffiro	1928		
	Navigatori	12	22	Antonio da Noli	1929		2580t, 107.3x10.2x3.4m, 4b,2gt, 50000hp, 38kts, 224p; 3x2-120/50, 2x1-40/39, 4x2-13.2, 2x2-533TT, 2DCT, 56m
			23	Leone Pancaldo	1929		
24			Luca Tarigo	1929			
25			Antonio Usodimare	1929			
26			Alvise da Mosto	1931			
27			Nicoloso da Recco	1930			
28			Giovanni di Verazzano	1930			
29			Lanzelotto Malocello	1930			
30			Emanuele Pessagno	1930			
31			Antonio Pigafetta	1931			
32			Ugolini Vivaldi	1930			
33			Nicoló Zeno	1930			
Freccia	4	34	Dardo	1932		2116t, 94.1(34,37)-96.2(35,36)x9.8x3.2m, 3b,2gt, 44000hp, 38kts, 185p; 2x2-120/50, 2x1-40/39, 2x2-13.2, 2x3-533TT, 2DCT, 54m	
		35	Freccia	1931			
		36	Saetta	1932			
		37	Strale	1932			
Folgore	4	38	Baleno	1932		2100t, 96.1x9.2x3.3m, 3b,2gt, 44000hp, 38kts, 185p; 2x2-120/50, 2x1-40/39, 2x2-13.2, 2x3-533TT, 2DCT, 54m	
		39	Folgore	1932			
		40	Fulmine	1932			
		41	Lampo	1932			

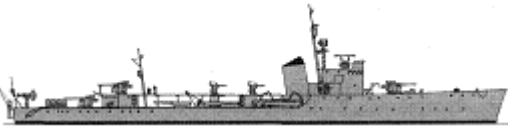
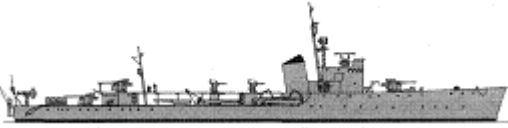
Maestrale	4	42	Grecale	1934		2207t, 106.7x10.2x3.3m, 3b,2gt, 44000hp, 38kts, 190p; 2x2-120/50, 2x1-40/39, 2x2-13.2, 2x3-533TT, 2DCT, 52m
		43	Libeccio	1934		
		44	Maestrale	1934		
		45	Scirocco	1934		
Oriani	4	46	Vittorio Alfieri	1937		2254t, 106.7x10.2x3.4m, 3b,2gt, 48000hp, 38kts, 206p; 2x2-120/50, 4x2-13.2, 2x3-533TT, 2DCT, 52m
		47	Giosue Carducci	1937		
		48	Vincenzo Gioberti	1937		
		49	Alfredo Oriani	1937		
Soldati-1	12	50	Alpino	1939		2460t, 106.7x10.2x3.5m, 3b,2gt, 48000hp, 38kts, 206p; 2x2-120/50, 1x1-120/15(50-55,57-61), (4x2+4x1)-13.2, 2x3-533TT, 2DCT, 48m
		51	Artigliere	1938		
		52	Ascari	1939		
		53	Aviere	1938		
		54	Bersagliere	1939		
		55	Camicia Nera	1938		
		56	Carabiniere	1938		
		57	Corazziere	1939		
		58	Fuciliere	1939		
		59	Geniere	1938		
		60	Granatiere	1939		
		61	Lanciere	1939		
Pilo	7	1	Rosolino Pilo	1915		912t, 73.0x7.3x2.3m, 4b,2t, 16000(1-4,7)-14800(5,6)hp, 30(1-4,7)-29(5,6)kts, 79p; 5x1-102/35, 2x1-40/39, 4x1-450TT, 10m
		2	Giuseppe Cesare Abba	1915		
		3	Giuseppe Dezza	1916		
		4	Giuseppe Missori	1916		
		5	Antonio Mosto	1915		
		6	Fratelli Cairoli	1915		
		7	Simone Schiaffino	1915		
Sirtori	4	8	Giuseppe Sirtori	1916		850t, 73.5x7.3x2.8m, 4b,2t, 15500hp, 30kts, 85p; 6x1-102/45, 2x1-40/39, 2x2-450TT, 10m
		9	Giovanni Acerbi	1917		
		10	Vincenzo Giordano Orsini	1917		
		11	Francesco Stocco	1917		
Audace	1	12	Audace	1917		1170t, 87.5x8.3x2.5m, 3b,2t, 22000hp, 30kts, 118p; 7x1-102/35, 2x1-40/39
La Masa	7	13	Giuseppe La Masa	1919		851t, 73.5x7.3x2.8m, 4b,2t, 15500hp, 30kts, 78p; 4x1-102/45, 2x1-76/40, 2x2-450TT, 10m
		14	Angelo Bassini	1918		
		15	Enrico Cosenz	1919		
		16	Giacinto Carini	1917		









TB							
		17	Nicola Fabrizzi	1918			
		18	Giuseppe La Farina	1919			
		19	Giacomo Medici	1918			
	Palestro	4	20	Palestro	1921		1076t, 81.9x8.0x2.7m, 4b,2t, 18000hp, 32kts, 118p; 4x1-102/45, 2x1-76/40, 2x2-450TT, 38m
			21	Confienza	1923		
			22	San Martino	1922		
			23	Solferino	1921		
	Generali	6	24	Generale Antonio Cantore	1921		870t, 73.5x7.3x2.7m, 4b,2t, 15500hp, 30kts, 118p; 3x1-102/45, 2x2-20/65, 2x2-450TT, 2DCT
			25	Generale Antonio Cascino	1922		
			26	Generale Antonio Chinotto	1921		
			27	Generale Carlo Montanari	1922		
			28	Generale Achille Papa	1922		
			29	Generale Marcello Prestinari	1922		
	Curtatone	4	30	Calatafimi	1924		1214t, 84.7x8.0x2.9m, 4b,2t, 22000hp, 32kts, 117p; 2x2-102/45, 2x1-76/30, 2x3-450TT, 16m
31			Castelfidardo	1924			
32			Curtatone	1923			
33			Monzambano	1924			
Albatros	1	34	Albatros	1934		490t, 70.5x6.9x1.7m, 2b,2gt, 4300hp, 24.5kts, 187p; 2x1-102/35, 2x1-37/54, 2x1-13.2, 4DCT, 2DCR	
Spica	2	35	Spica	1935		885t, 80.4x8.2x2.8m, 2b,2gt, 19000hp, 34kts, 99p; 3x1-100/47, 2x2-40/39, 2x2-13.2, 4x1-450TT, 2DCT, 28m	
		36	Astore	1935			
Climene	6	37	Canopo	1937		995t, 82.0x8.2x2.8m, 2b,2gt, 19000hp, 34kts, 99p; 3x1-100/47, 4x2-13.2, 4x1-450TT(37-39,41), (1x2+2x1)-450TT(40,42), 2DCT, 28m	
		38	Cassiopea	1937			
		39	Castore	1937			
		40	Centauro	1936			
		41	Cigno	1937			
		42	Climene	1936			
Perseo	8	43	Aldebaran	1936		1005t, 80.4x8.2x2.8m, 2b,2gt, 19000hp, 34kts, 99p; 3x1-100/47, 4x2-13.2, 2x2-450TT, 2DCT,	
		44	Altair	1936			
		45	Andromeda	1936			
		46	Antares	1936			

		47	Perseo	1936		28m
		48	Sagittario	1936		
		49	Sirio	1936		
		50	Vega	1936		
Alcione	16	51	Airone	1938		1035t, 80.4x7.9x3.1m, 2b,2gt, 19000hp, 34kts, 99p; 3x1-100/47, 4x2-13.2, 2x2-450TT(51-58,63-66), 4x1-450TT(59-62), 2DCT, 28m
		52	Alcione	1938		
		53	Aretusa	1938		
		54	Ariel	1938		
		55	Calipso	1938		
		56	Calliope	1938		
		57	Circe	1938		
		58	Clio	1938		
		59	Libra	1938		
		60	Lince	1938		
		61	Lira	1938		
		62	Lupo	1938		
		63	Pallade	1938		
		64	Partenope	1938		
		65	Pleiadi	1938		
		66	Polluce	1938		
Pegaso	4	67	Pegaso	1938		1575t, 89.3x9.7x3.7m, 2b,2gt, 16000hp, 28kts, 168p; 2x1-100/47, (3x2+2x1)-13.2, 2x2-450TT, 6DCT
		68	Procione	1938		
		69	Orione	1938		
		70	Orsa	1938		



## SUBMARINES





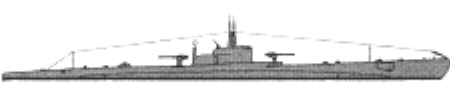
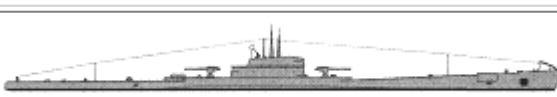
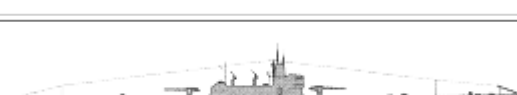

H	5	1	H1	1916		364/475t, 45.8x4.7x3.8m, 2d/em, 480/620hp, 12/11kts, 22p, 50m; 1x1-76/30, 4-450TT
		2	H2	1916		
		3	H4	1917		
		4	H6	1917		
		5	H8	1918		
X2	2	6	X2	1918		403/468t, 42.6x5.5x3.2m, 2d/em, 650/325hp, 8.2/6.3kts, 25p, 40m; 1x1-76/30, 2-450TT, 18m
		7	X3	1918		
Balilla	4	8	Balilla	1928		1427/1874t, 86.5x7.8x4.7m, 2d+1dg/em, 4900+425/2200hp, 16/7kts, 77p, 90m; 1x1-120/45, 2x2-13.2, 6-533TT, 4m(18,19,21)
		9	Domenico Millelire	1928		
		10	Antonio Sciesa	1929		
		11	Enrico Toti	1928		
		12	Pier Capponi	1929		

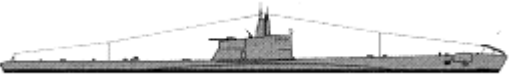

Mameli	4	13	Giovanni da Procida	1929		810/993t, 64.6x6.5x4.3m, 2d/em, 3000/1100hp, 15/7.5kts, 49p, 100m; 1x1-102/35, 2x1-13.2, 6-533TT
		14	Goffredo Mameli	1929		
		15	Tito Speri	1929		
Pisani	4	16	Giovanni Bausan	1929		866/1040t, 68.2x6.1x4.9m, 2d/em, 3000/1100hp, 15/8.2kts, 48p, 90m; 1x1-102/35, 2x1-13.2, 6-533TT
		17	Marcantonio Colonna	1929		
		18	Des Geneys	1929		
		19	Vettor Pisani	1929		
Fieramosca	1	20	Ettore Fieramosca	1930		1530/2094t, 84.0x8.3x5.1m, 2d/em, 5200/2300hp, 15/8kts, 78p, 90m; 1x1-120/45, 2x2-13.2, 8-533TT
Bandiera	4	21	Fratelli Bandiera	1930		925/1080t, 69.8x7.3x5.3m, 2d/em, 3000/1300hp, 15/8kts, 53p, 90m; 1x1-102/35, 2x1-13.2, 8-533TT
		22	Luciano Manara	1930		
		23	Ciro Menotti	1930		
		24	Santore Santarosa	1930		
Squalo	4	25	Delfino	1931		920/1125t, 69.8x7.2x5.2m, 2d/em, 3000/1300hp, 15/8kts, 53p, 90m; 1x1-102/35, 2x1-13.2, 8-533TT
		26	Narvalo	1930		
		27	Squalo	1930		
		28	Tricheco	1931		
Bragadin	2	29	Marcantonio Bragadin	1931		965/1068t, 68.0x7.1x4.3m, 2d/em, 1500/1000hp, 11.5/7kts, 55p, 90m; 1x1-102/35, 2x1-13.2, 4-533TT, 24m
		30	Filippo Corridoni	1931		
Settembrini	2	31	Luigi Settembrini	1932		938/1135t, 69.1x6.6x4.5m, 2d/em, 3000/1400hp, 17.5/7.7kts, 56p, 90m; 1x1-102/35, 2x1-13.2, 8-533TT
		32	Ruggiero Settimo	1932		
Argonauta	7	33	Argonauta	1932		650/800hp, 61.5x5.7x4.7m, 2d/em, 1200/800hp, 14/8kts, 44p, 80m; 1x1-102/35, 2x1-13.2, 6-533TT
		34	Fisalia	1932		
		35	Jalea	1933		
		36	Jantina	1933		
		37	Medusa	1932		
		38	Salpa	1932		
		39	Serpente	1932		
Sirena	12	40	Ametista	1934		680/837t, 60.2x6.5x4.7m, 2d/em, 1200/800hp, 14/7.7kts, 45p, 80m; 1x1-100/47, 2x2-13.2, 6-533TT
		41	Anfitrite	1934		
		42	Diamante	1933		
		43	Galatea	1934		
		44	Naiade	1933		
		45	Nereide	1934		
		46	Ondina	1934		
		47	Rubino	1934		
		48	Sirena	1933		
		49	Smeraldo	1933		
		50	Topazio	1934		

SS

		51	Zaffiro	1934		
Archimede	2	52	Galileo Galilei	1934		970/1239t, 70.5x6.9x4.1m, 2d/em, 3000/1100hp, 17/8kts, 55p, 90m; 2x1-100/43, 2x1-13.2, 8-533TT
		53	Galileo Ferraris	1935		
Glauco	2	54	Glauco	1935		1054/1305t, 73.0x7.2x5.1m, 2d/em, 3000/1200hp, 17/8kts, 58p, 90m; 2x1-100/47, 2x1-13.2, 8-533TT
		55	Otaria	1935		
Micca	1	56	Pietro Micca	1935		1545/1940t, 90.3x7.7x5.3m, 2d/em, 3000/1500hp, 15.5/8.5kts, 72p, 90m; 2x1-120/45, 2x2-13.2, 6-533TT, 20m
Calvi	3	57	Pietro Calvi	1935		1525/2028t, 84.3x7.7x5.2m, 2d/em, 4400/1800hp, 16.8/7.4kts, 77p, 100m; 2x1-120/45, 2x2-13.2, 8-533TT
		58	Giuseppe Finzi	1936		
		59	Enrico Tazzoli	1936		
Perla	10	60	Ambra	1936		680/844t, 60.2x6.5x4.7m, 2d/em, 1200/800hp, 14/7.5kts, 45p, 80m; 1x1-100/47, 2x2-13.2, 6-533TT
		61	Berillo	1936		
		62	Corallo	1936		
		63	Diaspro	1936		
		64	Gemma	1936		
		65	Iride	1936		
		66	Malacite	1936		
		67	Onice	1936		
		68	Perla	1936		
		69	Turchese	1936		
Adua	17	70	Adua	1936		680/844t, 60.2x6.5x4.7m, 2d/em, 1200/800hp, 14/7.5kts, 45p, 80m; 1x1-100/47, 2x2-13.2, 6-533TT
		71	Alagi	1937		
		72	Aradam	1937		
		73	Ascianghi	1938		
		74	Axum	1938		
		75	Beilul	1938		
		76	Dagabur	1937		
		77	Dessié	1937		
		78	Durbo	1938		
		79	Gondar	1938		
		80	Lafolé	1938		
		81	Macallé	1937		
		82	Neghelli	1938		
		83	Sciré	1938		
		84	Tembien	1938		
		85	Uarsciek	1937		
		86	Uebi Scebeli	1937		
		87	Atropo	1939		1305/1625t, 82.9x7.2x5.2m, 2d/em, 2880/1250hp, 16/8kts, 60p, 100m; 1x1-100/43, 2x2-13.2, 6-533TT,

	Foca	3	88	Foca	1937		36m
			89	Zoea	1938		
	Argo	2	90	Argo	1937		780/1000t, 63.2x6.9x4.5m, 2d/em, 1500/800hp, 14/8kts, 46p, 90m; 1x1-100/47, 2x2-13.2, 6-533TT
			91	Velella	1937		
	Marcello	9	92	Barbarigo	1938		1043/1290t, 73.0x7.2x5.1m, 2d/em, 3600/1100hp, 17.4/8kts, 57p, 100m; 2x1-100/47, 2x2-13.2, 8-533TT
			93	Dandolo	1938		
			94	Emo	1938		
			95	Marcello	1938		
			96	Mocenigo	1938		
			97	Morosini	1938		
			98	Nani	1938		
			99	Provana	1938		
			100	Veniero	1938		
	Cappellini	2	101	Comandante Cappellini	1939		1043/1290t, 73.0x7.2x5.1m, 2d/em, 3600/1100hp, 17.4/8kts, 57p, 100m; 2x1-100/47, 2x2-13.2, 8-533TT
			102	Comandante Faà di Bruno	1939		
	Brin	5	103	Archimede	1939		1000/1245t, 72.5x6.7x4.5m, 2d/em, 3400/1300hp, 17.3/8kts, 58p, 110m; 2x1-100/43, 4x1-13.2, 8-533TT
			104	Brin	1938		
			105	Galvani	1938		
			106	Guglielmotti	1938		
			107	Torricelli	1939		
	Liuzzi	2	108	Alpino Bagnolini	1939		1148/1460t, 76.1x7.0x4.6m, 2d/em, 2500/1500hp, 18/8kts, 58p, 90m; 2x1-100/47, 2x2-13.2, 8-533TT
			109	Console Generale Liuzzi	1939		
SSX	CA1	2	1, 2	CA1, 2	1938		13/16t, 10.0x2.0x1.6m, 1d/em, 60/25hp, 6.3/5kts, 2p; 2-450TR

## ESCORTS

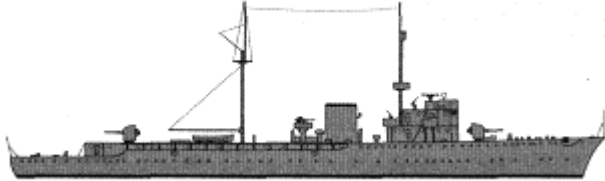
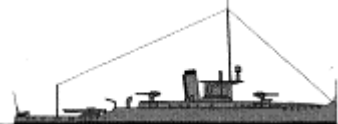



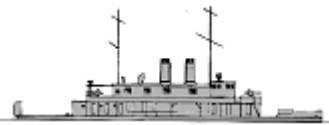

SL	Eritrea	1	1	Eritrea	1937		3068t, 96.9x13.3x3.5m, 2d/2dg,2em, 9100hp, 20kts, 234p; 2x2-120/45, 2x1-40/39, 4x1-13.2
PC	Bafile	1	1	Ernesto Giovannini	1922		284t, 52.1x5.7x1.8m, 2b,2vte, 2400hp, 24kts, 53p; 2x1-102/35, 1x2-450TT, 12m
			1	Cirene	1912		500t; 2x1-76/40
			2	Porto Corsini	1912		380t; 2x1-76/40
			3	Rimini	1912		420t; 2x1-76/40

APC	-	17	4	Alula	1912		430t; 1x1-76/40
			5	Gallipoli	1911		400t; 2x1-76/40
			6	Otranto	1911		385t; 2x1-76/40
			7	Valoroso	1913		420t; 2x1-76/40
			8	Palmaria	1911		286t; 1x1-76/40
			9	Basiluzzo	1915		110t
			10	Gaeta	1916		250t; 1x1-76/40
			11	Lampedusa	1915		166t; 1x1-76/40
			12	Lilibeo	1915		124t
			13	Liscanera	1916		222t; 1x1-76/40
			14	Porto d'Anzio	1914		166t; 1x1-76/40
			15	Portofino	1915		270t; 1x1-76/40
			16	Talamone	1916		190t; 1x1-76/40
			17	Terracina	1916		230t; 1x1-76/40

## OTHER FIGHTING SHIPS



PG	Sebastiano Caboto	1	1	Sebastiano Caboto	1912	No picture	1050t, 63.4x9.7x3.0m, 2b,2vte, 1200hp, 13.2kts, 107p; 6x1-76/40
APG	-	3	1	Abisso	1912		400t; 2x1-76/40
			2	Boeo	1916		235t; 1x1-76/40
			3	Palmaiola	1902		562t; 1x1-76/40
PR	Carlotto	1	1	Ermanno Carlotto	1921		218t, 48.8x7.5x0.9m, 2b,2vte, 1100hp, 14kts, 44p; 2x1-76/40



## COASTAL FORCES

PT	12t A-1 Baglietto	5	1 - 5	MAS204, 206, 210, 213, 216	1918		14t, 16.0x2.6x1.1m, 2pe, 700hp, 27kts, 7p; 2-450TT, 2DCR
	13t SVAN	4	6 - 9	MAS423-426	1928 - 1930		13t, 16.0x3.0x1.0m, 2pe, 1500hp, 40kts, 9p; 2-450TT
	14t SVAN	5	10 - 14	MAS430, 432 - 434, 437	1929 - 1934		14(10-13)-19(14)t, 16.0(10-13)-17.5(14) x3.3(10-13)-3.6(14) x1.0(10)-1.1(11-13)-1.3(14)m, 2pe(10-13)-2d(14), 1500hp, 40kts, 9(10)-13(11-14)p; 2-450TT, 1DCR
	14t Baglietto	1	15	MAS431	1932		16t, 16.0x4.0x1.3m, 2pe, 1500hp, 41kts, 7p; 2-450TT, 1DCR
	Türr	1	16	Stefano Türr	1937		64t, 32.0x6.0x0.9m, 4d, 3000hp, 30kts, 16p; 3x1-13.2, 4-450TT, 2DCR
	Baglietto experimental	1	17	MAS424	1937	No picture	21t, 16.5x4.3x1.2m, 2pe, 2000hp, 45kts, 8p; 2-450TT, 1DCR
	Class 500-1	25	18 - 42	MAS501-525	1937		21-24t, 17.0x4.3-4.7x1.3m, 2pe, 2000hp, 41-42kts, 9p; 2x1-13.2(18), 1x1-13.2(19-42), 2-450TT, 1DCR
	Class 500-2	25	43 - 67	MAS526-550	1939		26t, 18.7x4.7x1.5m, 2pe/pe, 2000/140hp, 42kts, 10p; 1x1-13.2, 2-450TT, 1DCR

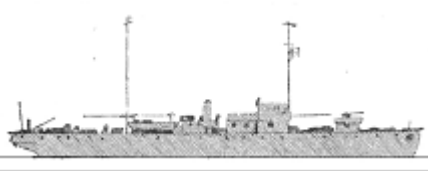
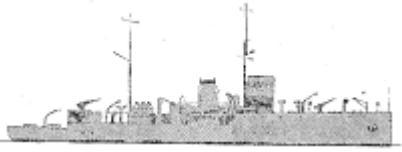
PS	40t Baglietto	2	1 - 4	MAS438-441	1934 - 1935	No picture	41t, 22.5x4.3x1.4m, 2pe, 2000hp, 32kts, 19p; 1x1-13.2, 2DCR
----	---------------	---	-------	------------	-------------	------------	---

## MINE WARFARE SHIPS

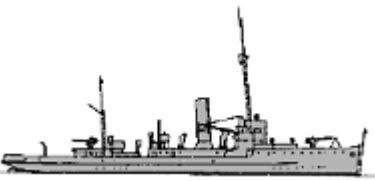
ML	Fasana	4	1	Fasana	1925		590t, 66.3x9.8x1.7m, 2d, 700hp, 10kts, 66p; 1x1-76/40, 54m, MS		
			2	Durazzo	1926				
			3	Buccari	1927				
			4	Pelagosa	1927				
	Ostia	4	5	Ostia	1926				850t, 62.2x8.7x2.6m, 2b,2vte, 1500hp, 15kts, 66p; 2x1-102/35, 1x1-76/40, 80m, MS
			6	Legnano	1927				
			7	Azio	1928				
			8	Lepanto	1928				
MS	RD1	38	1	RD4	1917		196-302t, 34.0-38.0x5.8-7.2x1.9-2.5m, 1b,1vte, 590-1150hp, 10-14kts, 22p; 1x1-76/40, MS		
			2	RD6	1917				
			3	RD7	1917				
			4	RD9	1917				
			5	RD12	1917				
			6	RD13	1918				
			7	RD16	1917				
			8	RD17	1917				
			9	RD18	1917				
			10	RD20	1917				
			11	RD21	1918				
			12	RD22	1918				
			13	RD23	1918				
			14	RD24	1918				
			15	RD25	1918				
			16	RD26	1918				
			17	RD27	1918				
			18	RD28	1918				
			19	RD29	1919				
			20	RD30	1919				
			21	RD31	1919				
			22	RD32	1919				
			23	RD33	1919				
			24	RD34	1919				
			25	RD35	1919				
			26	RD36	1919				
			27	RD37	1920				
			28	RD38	1921				

			29	RD39	1919		
			30	RD40	1920		
			31	RD41	1920		
			32	RD42	1920		
			33	RD43	1920		
			34	RD44	1920		
			35	RD49	1922		
			36	RD55	1925		
			37	RD56	1925		
			38	RD57	1926		
RD58	3		39	Albona	1920		145t, 31.8x6.5x1.7m, 1b,2vce, 280hp, 11kts, 27p; 1x1-76/40, 34m, MS
			40	Laurana	1920		
			41	Rovigno	1920		
Meteo	2		42	Vieste	1918		560t, 59.6x7.3x2.2m, 2b,2vte, 1850hp, 16kts, 40p; 2x1-105/42, 30m, MS
			43	Crotone	1918		
Lurana	2		44	Lurana	1923		205t, 45.5x6.0x1.4m, 1b,2vte, 750hp, 14.3kts, 35p; 1x1-76/40, MS
			45	Arco Azzurro	1923		
D1	1		46	D1	1938		188t, 33.4x6.6x2.2m, 1d, 450hp, 10kts, 18p; 1x1-76/40, MS
AMS	-	4	1	Pellegrino Matteucci	1924		620t; 1x1-76/40
			2	Mario Sonzini	1924		620t; 1x1-76/40
			3	Giovanni Berta	1924		620t; 1x1-76/40
			4	Giuseppe Biglieri	1924		620t; 1x1-76/40
MSB	Vedetta	2	1, 2	Vedetta, Vigilante	1937	No picture	70t, 26.1x4.3x1.3m, 2d, 400hp, 12kts, 21p; 1x1-76/40, 3x1-13.2, MS

### NAVAL AVIATION (approximately, maximal number of delivered planes signed)

Seaplanes	F: 100 M.7ter, 29 M.7ter AR, 50 Ro.44; R: 130 Ro.43
-----------	---



[home](#)

[World navies yesterday](#)

[1940](#)

# JAPAN 01 January 1940

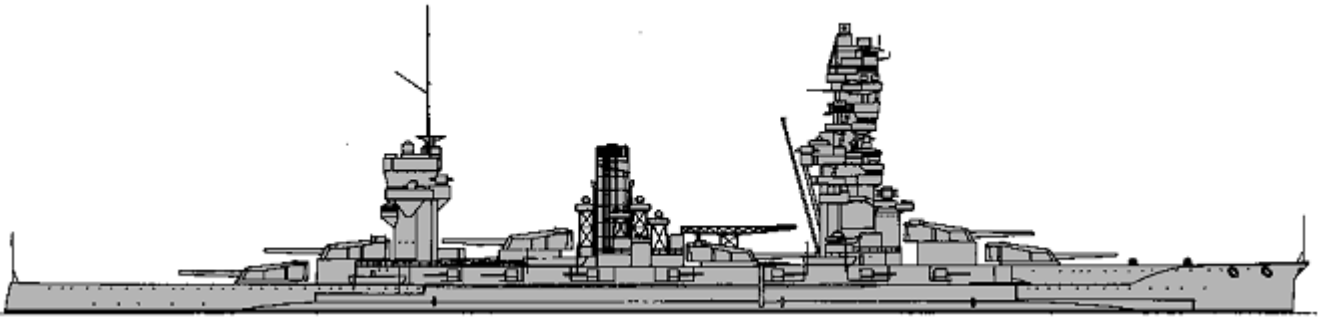
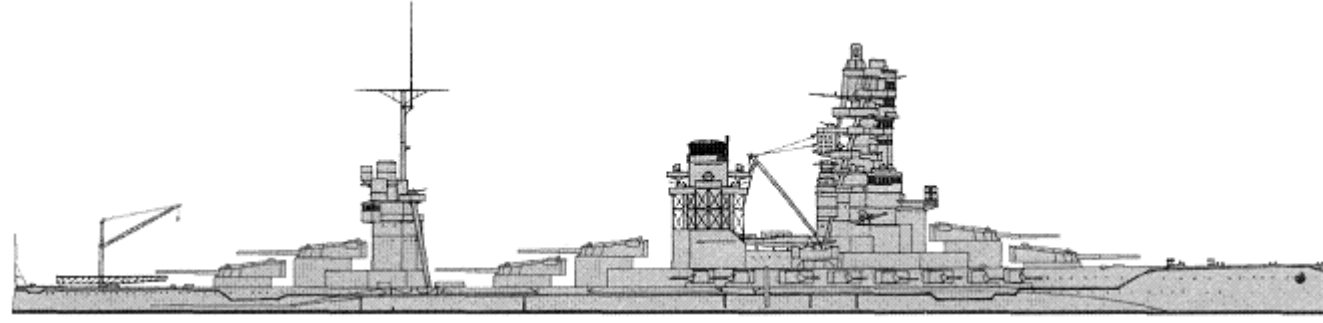
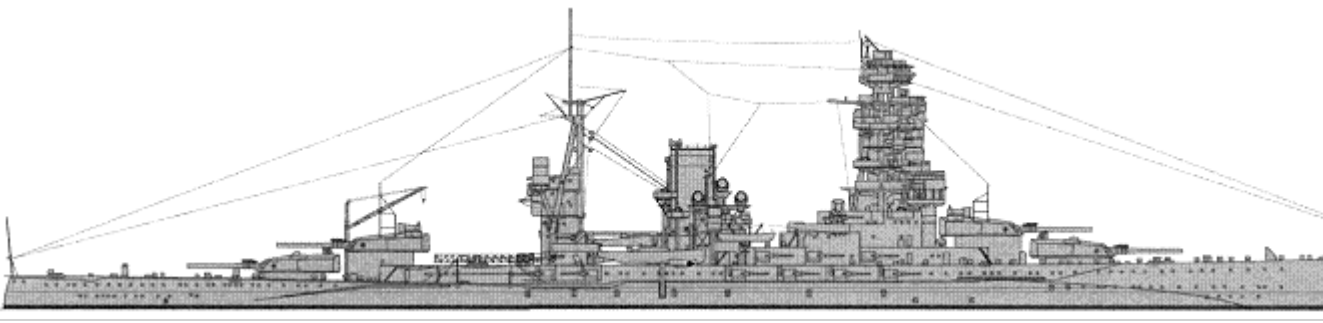
## CAPITAL SHIPS

	Fuso	1	Fuso	1915		39154t, 212.8x33.1x9.7m, 6b, 4gt, 75000hp, 24.7kts, 1396p; 305belt, 128deck, 305turrets, 350CT; 6x2-356/45, 14x1-152/50, 4x2-127/40, 8x2-25/60, 3seaplanes (2 E8N)
		2	Yamashiro	1917		
BB	Ise	3	Ise	1917		39657(1)-40169(2)t, 215.8x31.7x9.2m, 8b, 4gt, 80000hp, 25.3kts, 1376p; 305belt, 148deck, 305turrets, 305CT; 6x2-356/45, 16x1-140/50, 4x2-127/40, 10x2-25/60, 3seaplanes (2 E8N)
		4	Hyuga	1918		
	Nagato	5	Nagato	1920		42850t, 224.9x33.0x9.5m, 10b, 4gt, 82000hp, 25kts, 1368p; 305b, 197deck, 457turrets, 356CT; 4x2-410/45, 18x1-140/50, 4x2-127/40, 10x2-25/60, 3seaplanes (2 E8N)
		6	Mutsu	1921		
		1	Kongo	1913		36601t, 222.1x29.3x9.7m, 8b(1, 3)-11b(2, 4), 4gt, 136000hp, 30.5kts, 1437p; 203belt, 80deck,
		2	Hiei	1914		
		3	Kirishima	1915		

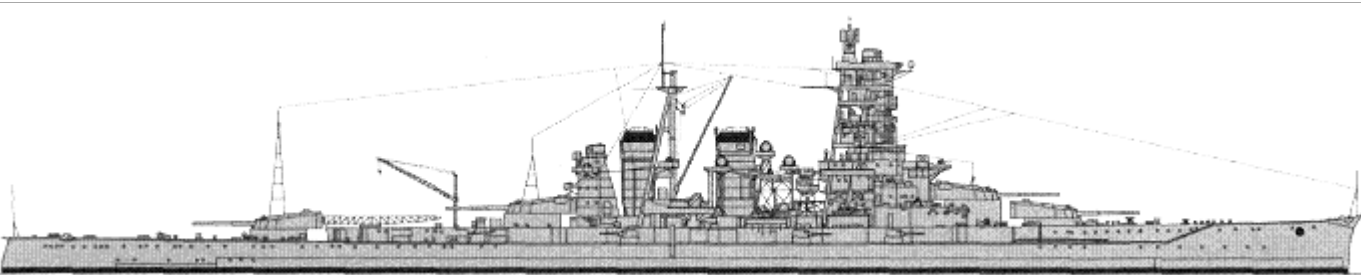
BC	Kongo	4				229turrets, 254CT; 4x2-356/45, 14x1-152/50, 4x2-127/40, 10x2-25/60, 3seaplanes (3 E8N)
			4	Haruna	1915	

### AIRCRAFT CARRYING SHIPS

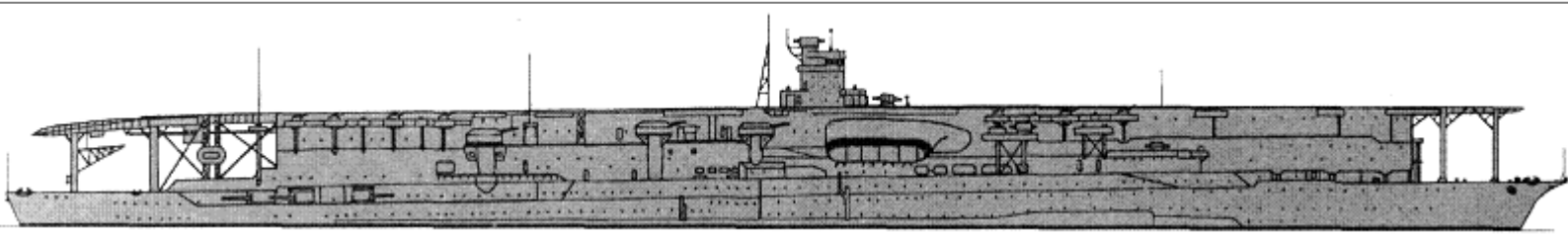
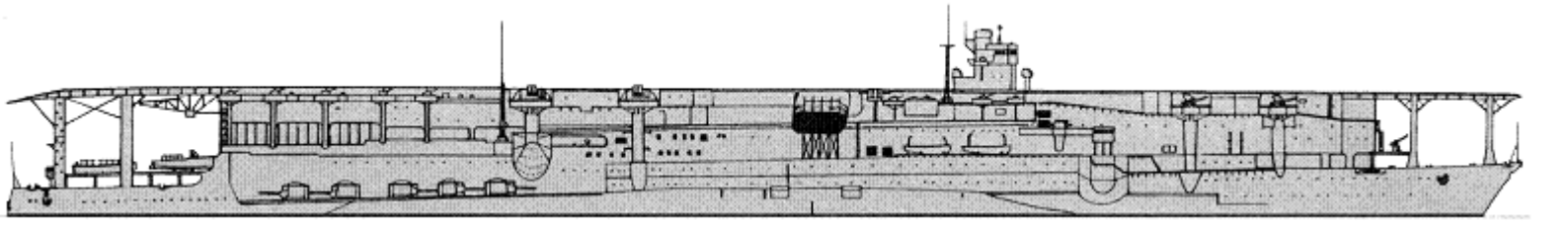
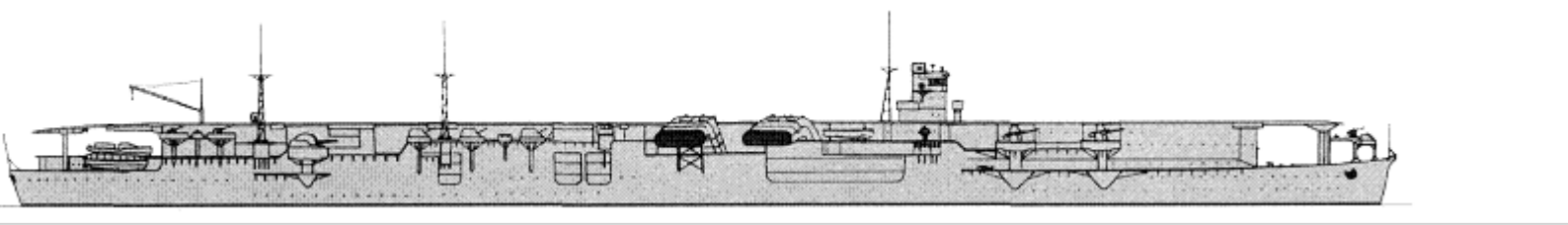
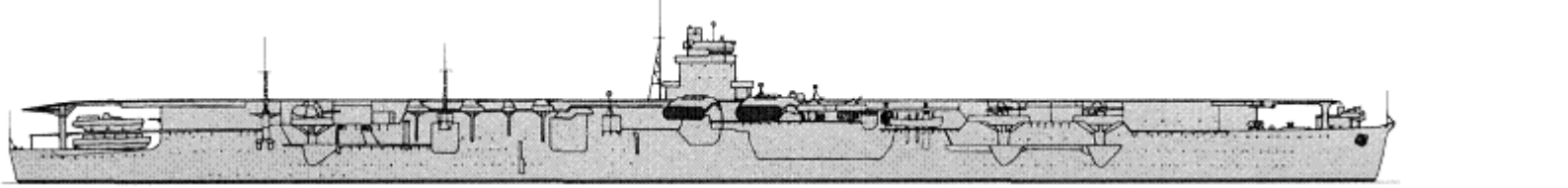
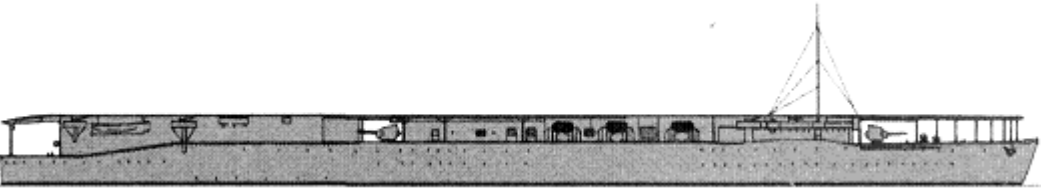
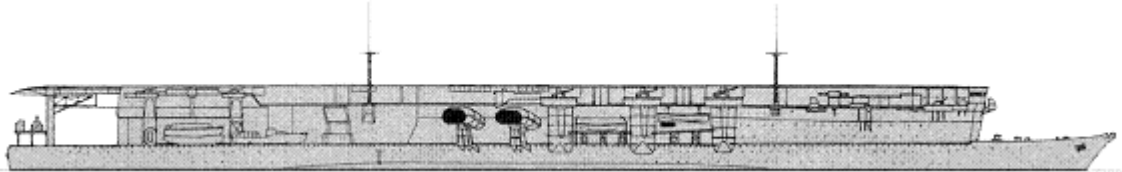
CV	Akagi	1	1	Akagi	1927		42750t, 260.7x31.3x8.7m, 19b, 4gt, 133000hp, 31.2kts, 2000p; 152belt, 57deck, 25casemates; 6x1-200/50, 6x2-120/45, 14x2-25/60, 91aircraft (16 A5M, 24 D1A, 54 B4Y)
	Kaga	1	2	Kaga	1928		43650t, 248.6x32.5x9.5m, 12b, 4gt, 127400hp, 28.3kts, 2016p; 152belt, 55deck, 25casemates; 10x1-200/50, 8x2-127/40, 11x2-25/60, 90aircraft (16 A5M, 14 D1A, 22 B4Y, B5M and B5N)
	Soryu	1	3	Soryu	1937		19800t, 227.5x26.0x7.6m, 8b, 4gt, 152000hp, 34.5kts, 1100p; 40belt, 25deck; 6x2-127/40, 14x2-25/60, 71aircraft (18 A5M, 27 D1A, 12 B4Y)
	Hiryu	1	4	Hiryu	1939		21900t, 227.4x27.0x7.8m, 8b, 4gt, 153000hp, 34.3kts, 1101p; 48belt, 25deck; 6x2-127/40, (7x3+5x2)-25/60, 73aircraft (16 A5M, 20 D1A, 38 B4Y)
CVL	Hosho	1	1	Hosho	1922		10797t, 168.1x22.7x6.2m, 8b, 2t, 30000hp, 25kts, 550p; 4x1-140/50, 4x1-76/40, 6x2-13.2/76, 26aircraft (9 A4N, 9 B4Y)
	Ryujo	1	2	Ryujo	1933		13650t, 179.9x23.0x7.1m, 6b, 2gt, 65000hp, 29kts, 600p; 4x2-127/40, 48aircraft (12 A4N and A5M, 15 D1A)



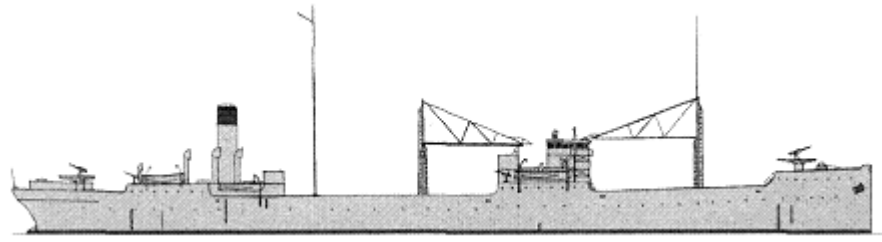
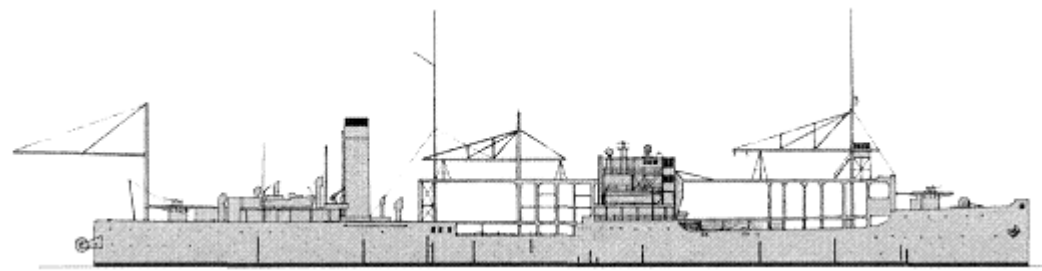
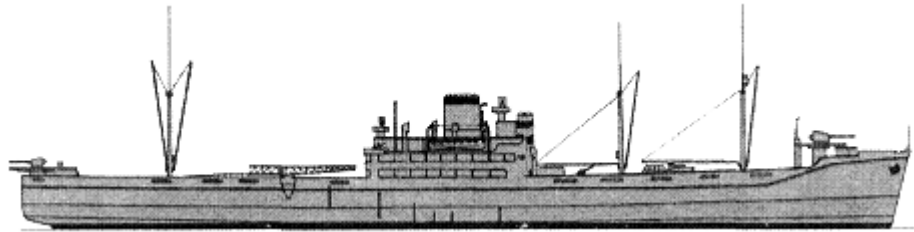
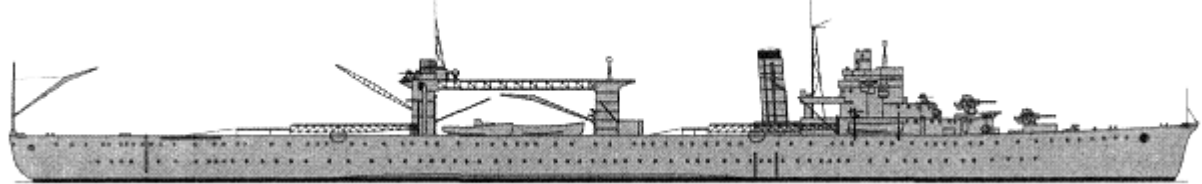
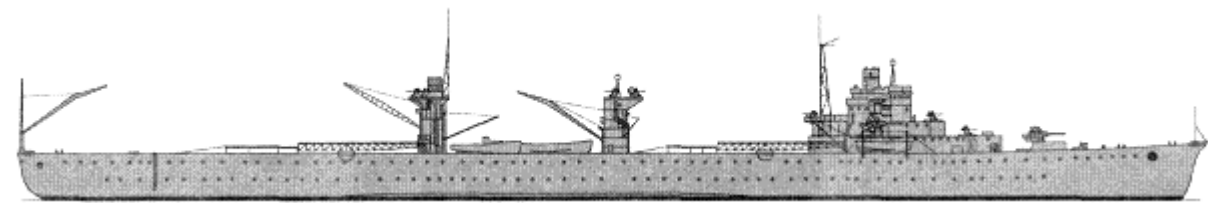

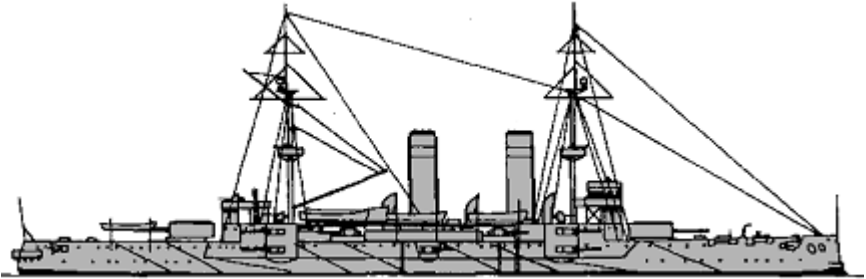

AV	Notoro	1	1	Notoro	1920		14050t, 138.9x17.7x8.1m, 4b, 2vte, 5850hp, 12kts, 155p; 2x1-120/45, 2x1-76/40, 10seaplanes (8 E8N)
	Kamoi	1	2	Kamoi	1922		19240t, 151.2x20.4x8.4m, 2b, 2tg, 2em, 9000hp, 15kts; 2x1-140/50, 2x1-76/40, 2x2-13.2/76, 12seaplanes (8 E8N)
	Kamikawa Maru	1	3	Kamikawa Maru	1936		6853brt, 146.0x19.0x9.0m, 1d, 7600hp, 17kts; 2x1-152, 2x1-13.2/76, 12seaplanes (8 E8N, 4 E7K)
	Chitose	2	4	Chitose	1938		12550t, 192.5x18.8x7.2m, 4b, 2gt+2d(2), 56800hp, 29kts; 2x2-127/40, 6x2-25/60, 24seaplanes (4 E7K, 16 E8N)
			5	Chiyoda	1938		
Mizuho	1	6	Mizuho	1939		12150t, 192.5x18.8x7.1m, 2d, 15200hp, 22kts; 3x2-127/40, 6x2-25/60, 24seaplanes (4 E7K, 16 E8N) or (12seaplanes+12 A-type midget submarines)	

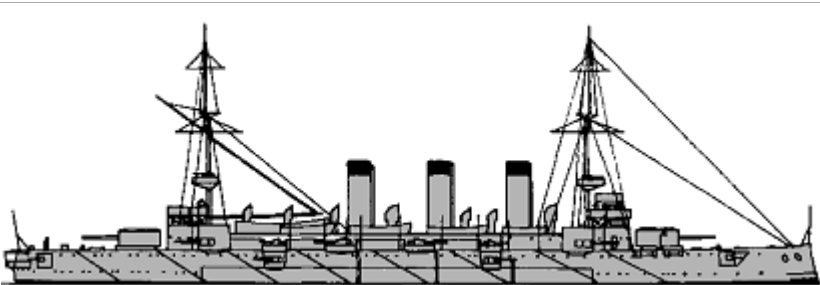
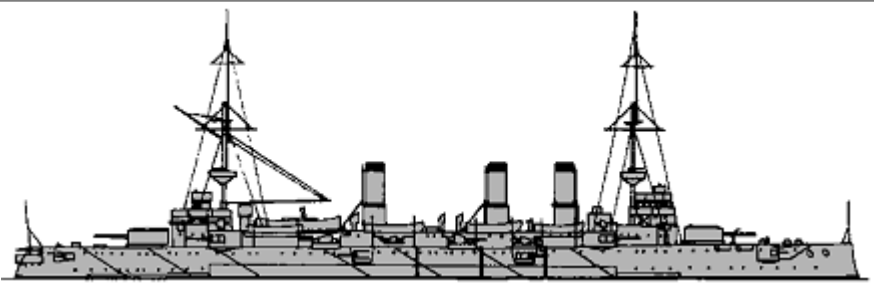
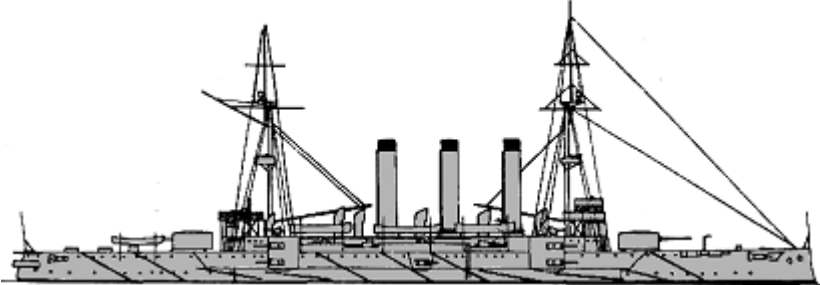
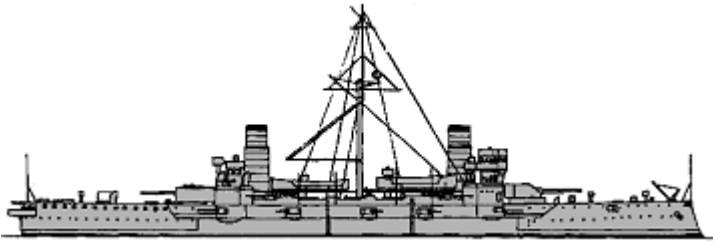
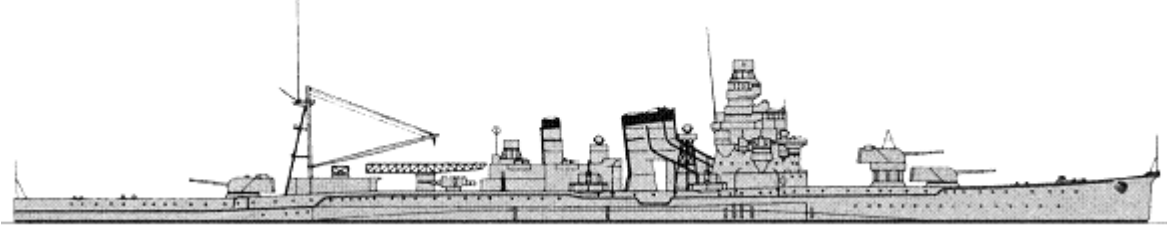
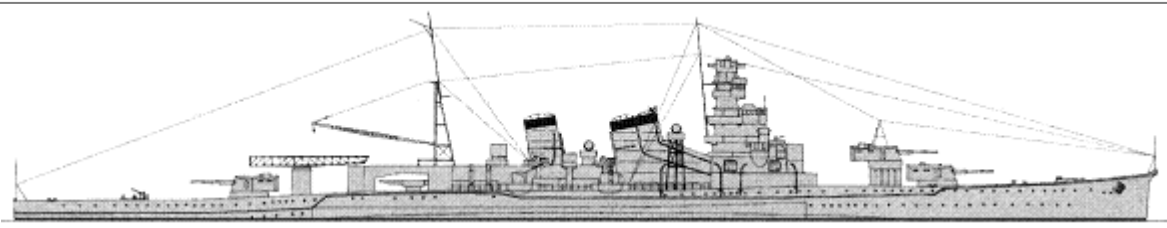

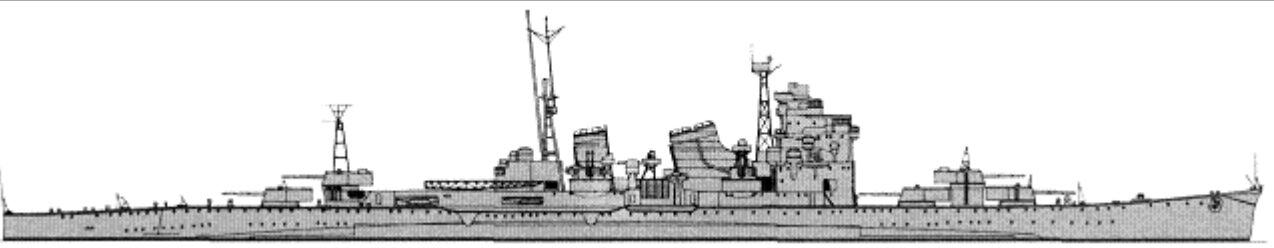
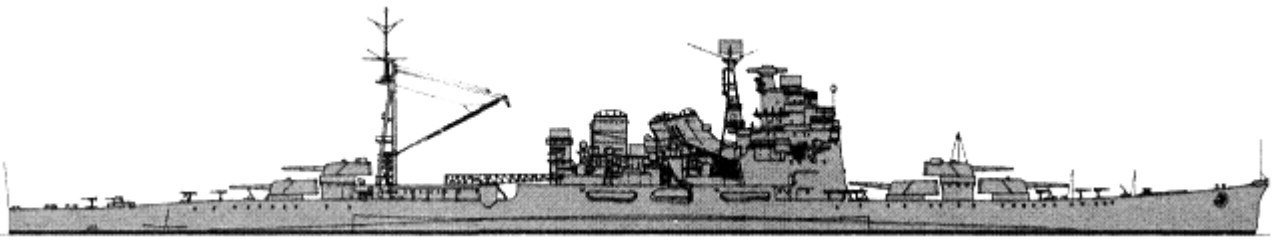
CRUISERS

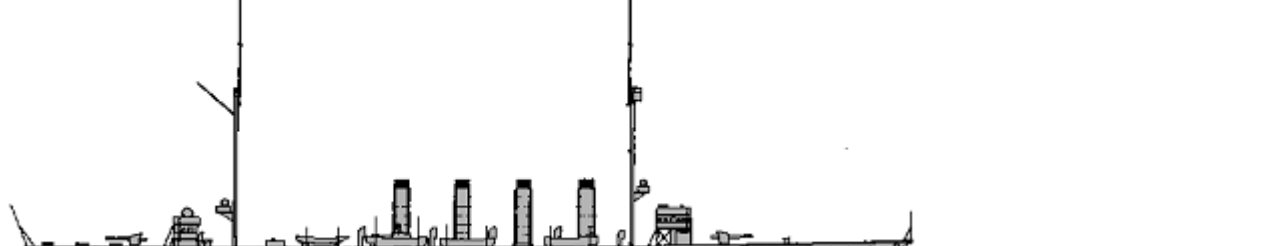
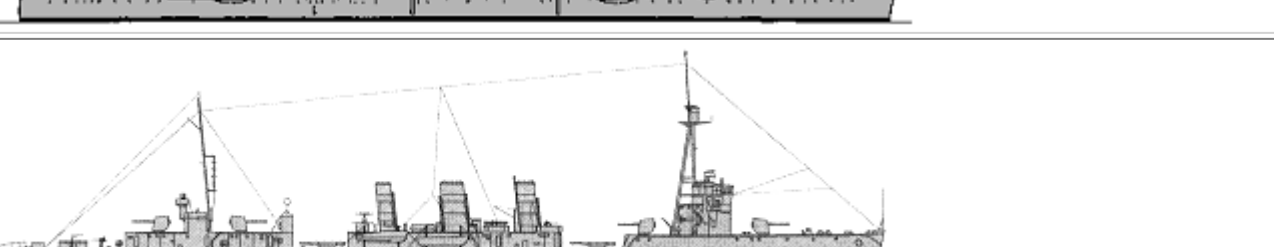
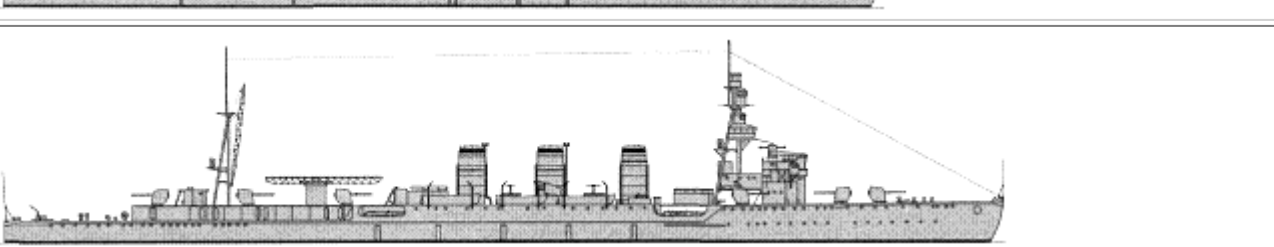

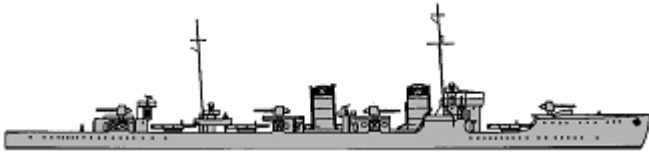
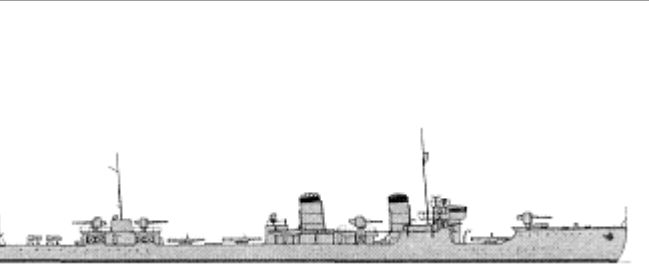

	Asama	1	1	Asama (TS)	1899		10500t, 134.7x20.5x7.4m, 6b,2vte, 7000hp, 16kts, 726p; Harvey: 178belt, 76deck, 152turrets, 356CT; 2x2-203/45, 8x1-152/40, 5x1-76/40
--	-------	---	---	------------	------	--	--

CA	Yakumo	1	2	Yakumo	1900		10300t, 132.3x19.6x7.2m, 6b, 2vte, 7000hp, 16kts, 700p; 178belt, 63deck, 152turrets, 356CT; 2x2-203/45, 8x1-152/40, 1x1-76/40
	Azuma	1	3	Azuma (TS)	1900		9953t, 137.9x20.9x7.2m, 6b,2vte, 9400hp, 16kts, 650p; 178belt, 63deck, 152turrets, 356CT; 2x2-203/45, 8x1-152/40, 5x1-76/40
	Izumo	2	4	Izumo	1900		10300t, 132.3x20.9x7.4m, 6b, 2vte, 7000hp, 16kts, 672p; 178belt, 63deck, 152turrets, 356CT; 2x2-203/45, 8x1-152/40, 1x1-76/40(4), 3x1-76/40(5)
			5	Iwate	1901		
	Kasuga	1	6	Kasuga	1904		8500t, 111.7x18.9x7.3m, 12b, 2vte, 13500hp, 20kts, 600p; 150belt, 38deck, 150turrets, 150CT; 1x1-254/40, 1x2-203/45, 4x1-152/40, 5x1-76/40, 4-450TT
	Furutaka	2	7	Furutaka	1926		11295t, 185.2x16.9x5.6m, 10b, 4gt, 11000hp, 33kts, 639p; 76belt, 35deck, 25turrets, 36CT; 3x2-203/50, 4x1-120/45, 4x2-25/60, 2x2-13.2/76, 2x4-610TT, 2seaplanes (1 E7K, 1 E8N)
			8	Kako	1926		
	Aoba	2	9	Aoba	1927		11660t, 185.2x17.6x5.7m, 12b, 4gt, 11000hp, 33kts, 657p; 76belt, 35deck, 25turrets, 36CT; 3x2-203/50, 4x1-120/45, 4x2-25/60, 2x2-13.2/76, 2x4-610TT, 2seaplanes (2 E7K)
			10	Kinugasa	1927		
			11	Nachi	1928		15391(11, 12, 14)-16007(13)t, 203.8x19.0(11, 12, 14)-20.7(13)x5.9(11, 12, 14)-6.4(13)m, 12b, 4gt, 13000hp, 34(11, 12, 14)-33.3(13)kts, 773p; 102belt, 90deck, 25turrets;
			12	Myoko	1929		
			13	Haguro	1929		

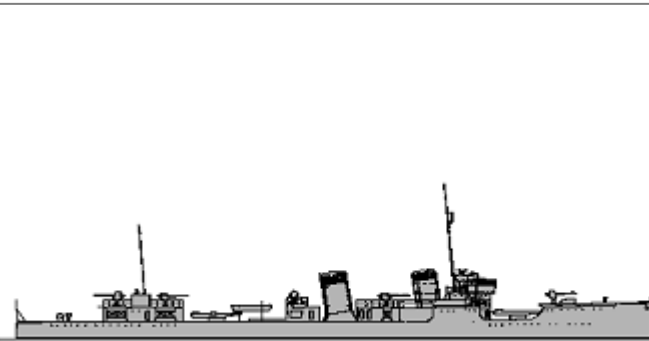
CL	Nachi	4					<p>5x2-203/50, 4x2-127/40, 4x2-25/60(13), 2x4-13.2/76(11, 12, 14), 2x2-13.2/76(13), 2x4-610TT(11, 12, 14), 4x4-610TT(13), 3seaplanes (1 E7K, 2 E8N)</p>	
		14	Ashigara	1929				
	Takao	4	15	Takao	1932		<p>15875(15, 16)-14260(17, 18)t, 203.8x20.7(15, 16)-19.0(17, 18)x6.3(15, 16)-6.1(17, 18)m, 12b, 4gt, 130000hp, 34.3(15, 16)-35.5(17, 18)kts, 773p; 102belt, 90deck, 25turrets, 16CT; 5x2-203/50, 4x1-120/45, 4x2-25/60(15, 16), 2x2-13.2/76(15, 16), 2x4-13.2/76(17, 18), 4x4-610TT(15, 16), 4x2-610TT(17, 18), 3seaplanes (1 E7K, 2 E8N), 4DCR(15, 16)</p>	
			16	Atago	1932			
			17	Maya	1932			
			18	Chokai	1932			
	Tone	2	19	Tone	1938		<p>15200t, 201.6x19.4x6.5m, 8b, 4gt, 152000hp, 35kts, 850p; 100belt, 65deck, 25turrets; 4x2-203/50, 4x2-127/40, 6x2-25/60, 4x3-610TT, 6seaplanes (2 E7K, 3 E8N)</p>	
			20	Chikuma	1939			
	Chikuma	2	1	Hirado	1912		<p>5040t, 144.8x14.2x5.1m, 6b, 2t, 22500hp, 26kts, 414p; 89belt, 57deck, 25shields, 102CT; 8x1-152/45, 4x1-76/40(1), 5x1-76/40(2), 2x2-533TT</p>	
			2	Yahagi	1912			
Tenryu		2	3	Tenryu	1919		<p>4350t, 142.9x12.3x4.0m, 10b, 3gt, 51000hp, 33kts, 327p; 63belt, 25deck, 20shields, 51CT; 4x1-140/50, 1x1-76/40, 2x1-13.2/76, 2x3-533TT, 48mines</p>	
	4		Tatsuta	1919				
Kuma	5	5	Kuma	1920		<p>8000t, 162.2x14.2x4.8m, 12b, 4gt, 90000hp, 32kts, 450p; 63belt, 45deck, 20shields, 51CT; 7x1-140/50, 2x2-25/60, 4x2-533TT, 48mines, 1seaplane(5, 6) (1 E7K)</p>		
		6	Tama	1921				
		7	Kitakami	1921				
		8	Oi	1921				
		9	Kiso	1921				
Nagara	6	10	Nagara	1922		<p>8000t, 162.2x14.2x4.8m, 12b, 4gt, 90000hp, 32kts, 450p; 63belt, 20shields, 29deck, 51CT; 7x1-140/50, 2x2-25/60, 1x4-13.2/76, 4x2-610TT, 48mines, 1seaplane (1 E7K)</p>		
		11	Natori	1922				
		12	Kinu	1922				
		13	Isuzu	1923				
		14	Yura	1923				

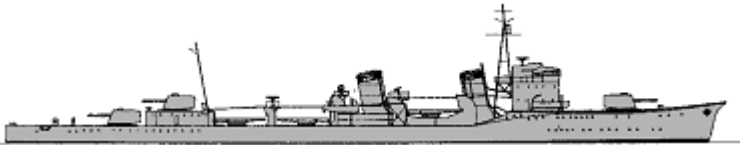





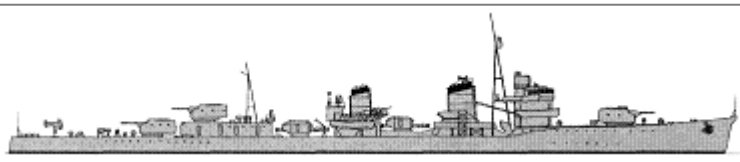
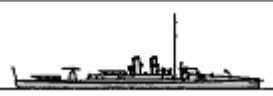
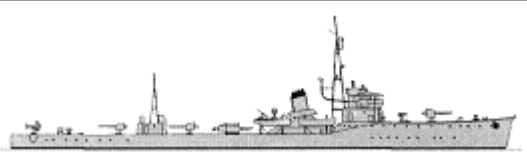
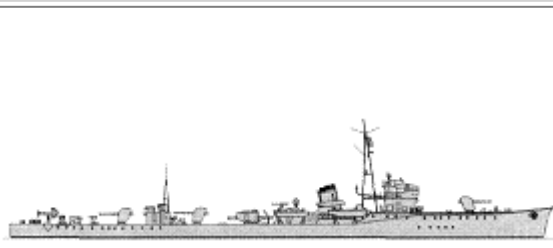

Minekaze	11	15	Akikaze	1921		1650(12, 14)-1800(13, 15-22)t, 102.6x9.0x2.9m, 4b, 2gt, 38500hp, 39(12, 14)-36(13, 15-22)kts, 148p; 4x1-120/45(12, 13, 15-22), 2x1-120/45(14), 3x2-533TT(12, 13, 15-22), 20mines(12, 13, 15-22)				
		16	Shiokaze	1921						
		17	Yukaze	1921						
		18	Hokaze	1921						
		19	Tachikaze	1921						
		20	Nokaze	1922						
		21	Namikaze	1922						
		22	Numakaze	1922						
		Kamikaze	9	23			Kamikaze	1922		1720t, 102.6x9.1x2.9m, 4b, 2gt, 38500hp, 37.2kts, 148p; 4x1-120/45, 3x2-533TT, 4DCT, 20mines, sweeps
				24			Asakaze	1923		
				25			Harukaze	1923		
26	Matsukaze			1924						
27	Hatakaze			1924						
28	Oite			1925						
29	Hayate			1925						
30	Asanagi			1925						
31	Yunagi			1925						
Wakatake	7	32	Wakatake	1922		1300(32, 34)-1100(33, 35-38)t, 85.3x7.9x2.5m, 3b, 2gt, 21500hp, 31(32, 34)-35.5(33, 35-38)kts, 110p; 3x1-120/45, 2x2-533TT, 20mines, MS				
		33	Kuretake	1922						
		34	Sanae	1923						
		35	Asagao	1923						
		36	Fuyo	1923						
		37	Karukaya	1923						
		38	Yugao	1924						
Mutsuki	12	39	Kisaragi	1925		1772t, 102.7x9.2x3.0m, 4b, 2gt, 38500hp, 37.2kts, 150p; 4x1-120/45, 1x2-25/60(40, 44-48), 2x3-610TT, 2DCT, 16mines, MS				
		40	Satsuki	1925						
		41	Mutsuki	1926						
		42	Yayoi	1926						
		43	Uzuki	1926						
		44	Fumizuki	1926						
		45	Kikuzuki	1926						
		46	Minazuki	1927						
		47	Nagatsuki	1927						
		48	Mikazuki	1927						
		49	Mochizuki	1927						
		50	Yuzuki	1927						
DD		51	Fubuki	1928						
		52	Shinonome	1928						
		53	Usugumo	1928						
		54	Shirakumo	1928						
		55	Isonami	1928						

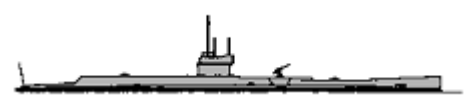
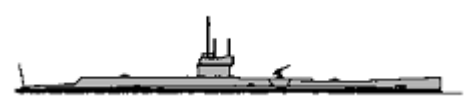
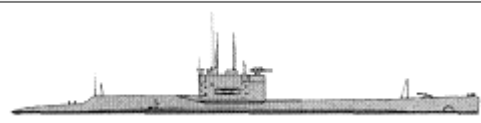
Fubuki	19	56	Shirayuki	1928		2570t, 118.4x10.4x3.2m, 4b, 2gt, 50000hp, 34kts, 197p; 3x2-127/50, 2x2-25/60, 3x3-610TT, 2DCT, 18mines
		57	Murakumo	1928		
		58	Hatsuyuki	1929		
		59	Uranami	1929		
		60	Shikinami	1929		
		61	Ayanami	1930		
		62	Asagiri	1930		
		63	Yugiri	1930		
		64	Amagiri	1930		
		65	Sagiri	1931		
		66	Oboro	1931		
		67	Akebono	1931		
		68	Ushio	1931		
69	Sazanami	1932				
Akatsuki	4	70	Akatsuki	1932		2560t, 118.4x10.4x3.3m, 3b, 2gt, 50000hp, 34kts, 197p; 3x2-127/50, 2x2-25/60, 3x3-610TT, 2DCT, 18mines
		71	Ikazuchi	1932		
		72	Inazuma	1932		
		73	Hibiki	1933		
Hatsuharu	6	74	Hatsuharu	1933		2240t, 109.5x10.0(74-77)-10.3(78, 79)x3.0m, 3b, 2gt, 42000hp, 33.3kts, 200p; (2x2+1x1)-127/50, 2x1-13.2/76, 2x3-610TT, 2DCT
		75	Nenohi	1933		
		76	Hatsushimo	1934		
		77	Wakaba	1934		
		78	Yugure	1935		
		79	Ariake	1935		
Shiratsuyu	10	80	Shiratsuyu	1936		2090t, 110.0x9.9x3.5m, 3b, 2gt, 42000hp, 34kts, 180p; (2x2+1x1)-127/50, 2x1-13.2/76, 2x4-610TT, 2DCT
		81	Shigure	1936		
		82	Murasame	1937		
		83	Yudachi	1937		
		84	Samidare	1937		
		85	Harusame	1937		
		86	Yamakaze	1937		
		87	Kawakaze	1937		
		88	Umikaze	1937		
		89	Suzukaze	1937		
Asashio	10	90	Asashio	1937		2500t, 118.3x10.4x3.7m, 3b, 2gt, 50000hp, 35kts, 200p; 3x2-127/50, 2x2-25/60, 2x4-610TT, 2DCT
		91	Oshio	1937		
		92	Michishio	1937		
		93	Arashio	1937		
		94	Natsugumo	1938		
		95	Yamagumo	1938		

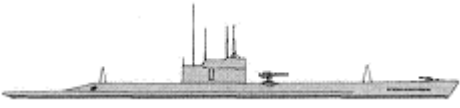
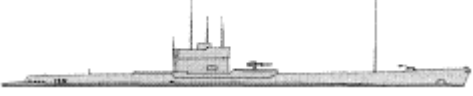
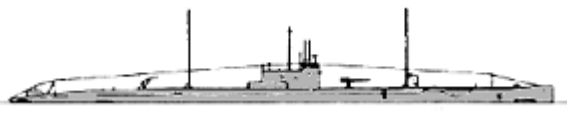

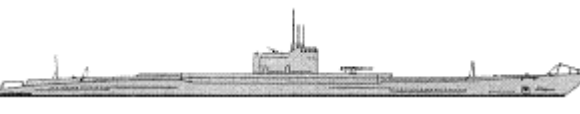

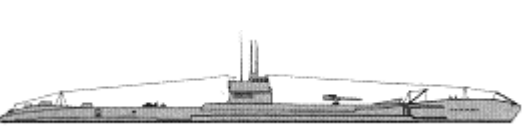
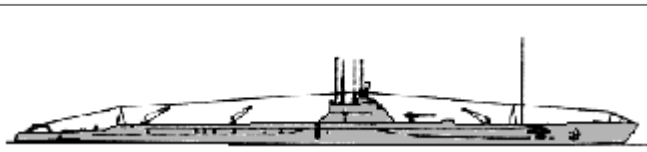
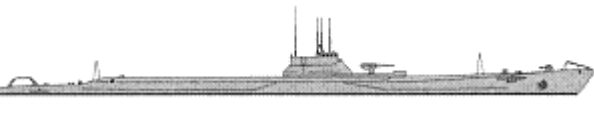
TB			96	Minegumo	1938		
			97	Asagumo	1938		
			98	Arare	1938		
			99	Kasumi	1938		
	Kagero	2	100	Kagero	1939		2600t, 118.5x10.8x3.8m, 3b, 2gt, 52000hp, 35kts, 240p; 3x2-127/50, 2x2-25/60, 2x4-610TT, 2DCT
			101	Shiranui	1939		
	Kawasemi	1	1	Kawasemi	1907		96t, 41.1x4.8x2.4m, 1b, 1vte, 1200hp, 23kts, 40p; 2x1-47/40, (1+2x1)-356TT
	Tomozuru	4	2	Chidori	1933		815t, 82.0x7.4x2.8m, 2b, 2gt, 11000hp, 28kts, 113p; 3x1-120/45, 1x2-533TT, 2DCT
			3	Tomozuru	1934		
			4	Manazuru	1934		
			5	Hatsukari	1934		
	Otori	8	6	Otori	1936		1040t, 88.5x8.2x2.8m, 2b, 2gt, 19000hp, 30.5kts, 113p; 3x1-120/45, 1x1-40/62, 1x3-533TT, 2DCT
			7	Hiyodori	1936		
8			Hayabusa	1936			
9			Kasasagi	1937			
10			Hato	1937			
11			Sagi	1937			
12			Kari	1937			
13	Kiji	1937					

## SUBMARINES

L1	1	1	RO51	1920		893/1195t, 70.6x7.2x3.9m, 2d/em, 2400/1600hp, 17/8kts, 48p, 60m; 1x1-76/23, 6-450TT
L2	1	2	RO56	1922		893/1195t, 70.6x7.1x3.9m, 2d/em, 2400/1600hp, 17/8kts, 48p, 60m; 1x1-76/23, 4-450TT
L3	3	3	RO57	1922		897/1195t, 76.2x7.2x4.0m, 2d/em, 2400/1600hp, 17/8kts, 48p, 60m; 1x1-76/40, 4-533TT
		4	RO58	1922		
		5	RO59	1923		
K4	3	6	RO26	1923		770/1080t, 74.2x6.1x3.7m, 2d/em, 2600/1200hp, 17/9kts, 45p, 45m; 1x1-76/23, 4-533TT
		7	RO27	1924		
		8	RO28	1923		
		9	RO30	1924		

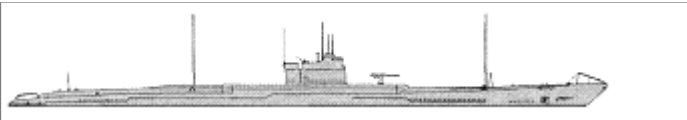
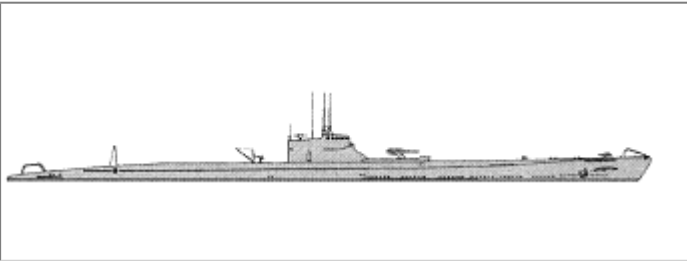
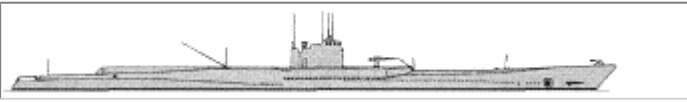

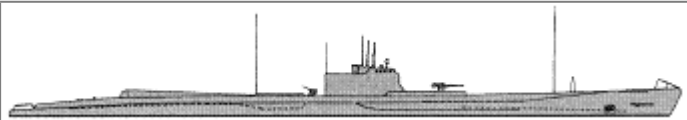
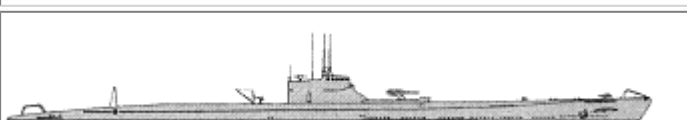
SS	KT	3	10	RO31	1927		665/1030t, 74.2x6.1x3.7m, 2d/em, 1200/1200hp, 13/8kts, 43p, 75m; 1x1-120/45, 4-533TT
			11	RO32	1924		
	L4	9	12	RO60	1923		996/1322t, 76.2x7.4x3.8m, 2d/em, 2400/1600hp, 16.5/9kts, 47p, 60m; 1x1-76/40, 6-533TT
			13	RO61	1924		
			14	RO62	1924		
			15	RO63	1924		
			16	RO64	1925		
			17	RO65	1926		
			18	RO66	1927		
			19	RO67	1926		
			20	RO68	1925		
	KD1	1	21	I51	1924		1500/2430t, 91.4x8.8x4.6m, 2d/em, 2600/1000hp, 14.5/6.2kts, 60p, 60m; 1x1-120/45, 8-533TT
	KD2	1	22	I52	1925		1500/2500t, 100.9x7.6x5.1m, 2d/em, 6800/2000hp, 22/10kts, 60p, 60m; 1x1-120/45, 1x1-76/40, 8-533TT
	J1	4	23	I1	1926		2135/2791t, 97.5x9.2x5.0m, 2d/em, 6000/2600hp, 18/8kts, 92p, 80m; 2x1-140/40, 6-533TT
			24	I2	1926		
			25	I3	1926		
			26	I4	1929		
	KD3a	4	27	I53	1927		1800/2300t, 100.6x8.0x4.8m, 2d/em, 6800/1800hp, 20/8kts, 64p, 60m; 1x1-120/45, 8-533TT
			28	I54	1927		
			29	I55	1927		
30			I58	1928			
KRS	4	31	I21	1927		1383/1768t, 85.2x7.5x4.4m, 2d/em, 2400/1100hp, 14.5/7kts, 51p, 75m; 1x1-140/40, 4-533TT, 42mines	
		32	I22	1927			
		33	I23	1928			
		34	I24	1928			
KD3b	4	35	I56	1929		1800/2300t, 101.0x7.9x4.9m, 2d/em, 6800/1800hp, 20/8kts, 79p, 60m; 1x1-120/45, 8-533TT	
		36	I57	1929			
		37	I59	1930			
		38	I60	1929			
KD4	3	39	I61	1929		1720/2300t, 97.7x7.8x4.8m, 2d/em, 6000/1800hp, 20/8.5kts, 58p, 60m; 1x1-120/45, 6-533TT	
		40	I62	1930			
		41	I64	1930			
KD5	3	42	I65	1932		1705/2330t, 97.7x8.2x4.7m, 2d/em, 6000/1800hp, 20.5/8.2kts, 75p, 75m; 1x1-100/50, 1x1-13.2/76, 6-533TT	
		43	I66	1932			
		44	I67	1932			



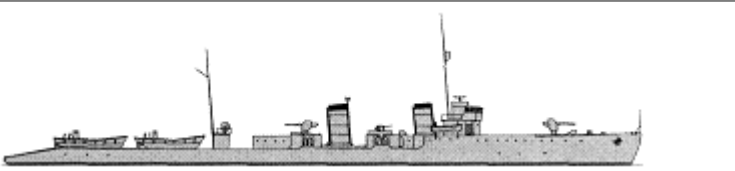
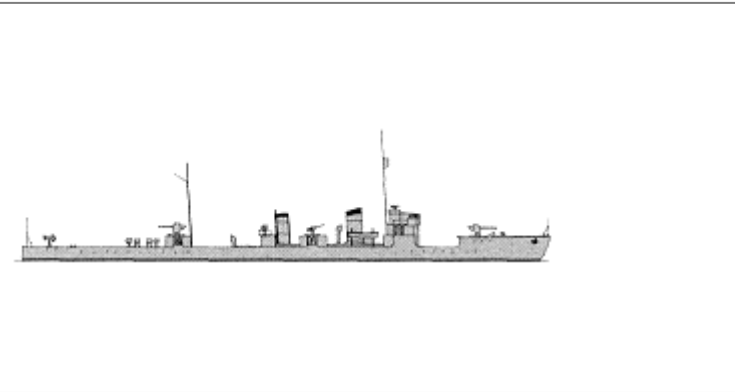

J1M	1	45	I5	1932		2243/2921t, 97.5x9.1x4.9m, 2d/em, 6000/2600hp, 18/8kts, 93p, 80m; 1x1-140/40, 6-533TT, 1seaplane (1 E9W)
KD6a	6	46	I68	1934		1785/2440t, 104.7x8.2x4.6m, 2d/em, 9000/1800hp, 23/8.2kts, 84p, 70(46, 47)-75(48-51)m; 1x1-120/45(49-51), 1x1-100/50(46-48), 1x1-13.2/76, 6-533TT
		47	I69	1935		
		48	I70	1935		
		49	I71	1935		
		50	I72	1937		
		51	I73	1937		
J2	1	52	I6	1935		2243/3061t, 98.5x9.1x5.3m, 2d/em, 8000/2600hp, 20/7.5kts, 97p, 80m; 1x1-127/40, 1x1-13.2/76, 6-533TT, 1seaplane (1 E9W)
K5	2	53	RO33	1935		940/1200t, 75.7x6.7x4.0m, 2d/em, 2900/1200hp, 19/8.2kts, 61p, 75m; 1x1-76/40, 1x1-13.2/76, 4-533TT
		54	RO34	1937		
J3	2	55	I7	1937		2525/3538t, 109.3x9.1x5.3m, 2d/em, 11200/2800hp, 23/8kts, 100p, 100m; 1x1-140/40, 2x1-13.2/76, 6-533TT, 1seaplane (1 E9W)
		56	I8	1938		
KD6b	2	57	I74	1938		1810/2564t, 105.0x8.2x4.6m, 2d/em, 9000/1800hp, 23/8kts, 84p, 80m; 1x1-120/45, 1x2-13.2/76, 6-533TT
		58	I75	1938		
No71	1	59	No71	1938		213/240t, 42.8x3.3x3.1m, 1d/em, 300/1800hp, 13.1/21.3kts, 11p, 85m; 3-450TT
SSX	A	20	1 - 20 HA1 - 20	1936 - 1939		/45t, 23.9x1.9x1.9m, 1em, 600hp, 19/24kts, 2p; 2-450TT

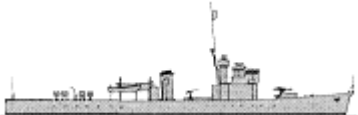

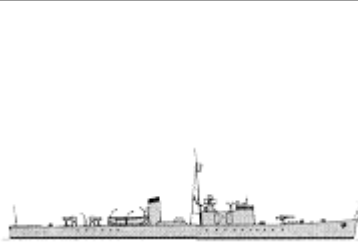
## ESCORTS

Minekaze	2	1	P1	1920		1700t, 102.6x9.0x2.9m, 2b, 2gt, 19250hp, 22kts, 148p; 2x1-120/45, 5x2-25/60, 2DCT, 20mines
		2	P2	1921		
Momi	9	3	P31	1920		1162t, 85.3x7.9x2.4m, 2b, 2gt, 12000hp, 18kts, 110p; 2x1-120/45, 3x2-25/60, 4DCT, 20mines
		4	P32	1920		
		5	P33	1921		
		6	P34	1921		
		7	P35	1921		
		8	P36	1921		
		9	P37	1922		
		10	P38	1922		
		11	P39	1922		
Ch1	2	1	Ch1	1934		400t, 65.3x5.9x2.0m, 2d, 3400hp, 21kts, 45p; 1x2-40/62, 2DCR
		2	Ch2	1934		

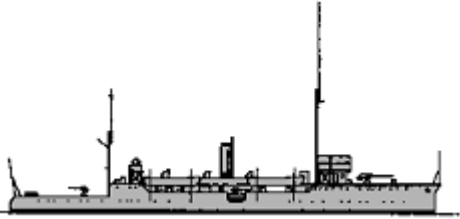
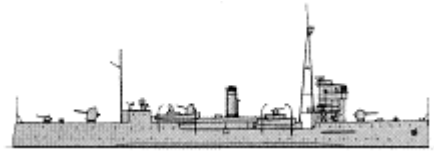

PC							
	Ch3	1	3	Ch3	1936		284t, 56.1x5.6x2.2m, 2d, 2500hp, 20kts, 45p; 1x2-40/62, 2DCR
	Ch51	2	4	Ch51	1937		175t, 45.0x4.8x1.7m, 2d, 3000hp, 23kts, 41p; 1x1-40/62, 2DCT
			5	Ch52	1937		
	Ch53	1	6	Ch53	1937		180t, 45.0x4.8x1.7m, 2b, 2gt, 3000hp, 23kts, 41p; 1x1-40/62, 2DCT
	Ch4	9	7	Ch4	1938		309t, 56.2x5.6x2.2m, 2d, 2600hp, 20kts, 59p; 1x2-40/62, 2DCT
			8	Ch5	1938		
			9	Ch6	1939		
			10	Ch7	1938		
			11	Ch8	1938		
12			Ch9	1939			
13			Ch10	1939			
14			Ch11	1939			
15	Ch12	1939					

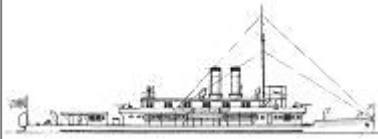
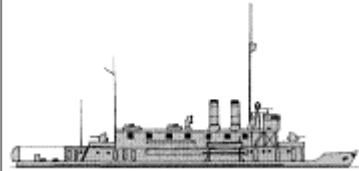
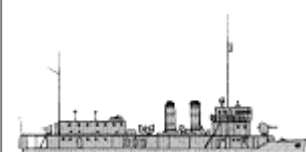
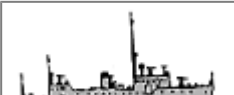
## OTHER FIGHTING SHIPS

PG	Saga	1	1	Saga	1912		885t, 69.0x9.0x2.2m, 2b, 2vte, 1600hp, 15kts, 98p; 1x1-120/45, 3x1-76/40
	Ataka	1	2	Ataka	1923		1094t, 71.7x9.8x2.3m, 2b, 2vte, 1700hp, 16kts, 118p; 1x1-120/45, 2x1-76/40, 4x2-13.2/76, 1DCT
	Atada	1	3	Atada	1930		1520t, 82.3x10.5x3.4m, 3b, 2vte, 4000hp, 15kts, 173p; 3x1-76/40, 2x2-13.2/76
			1	Akitsu Maru	1936		1038brt, 60.0x10.0x4.9m, 1vte, 670hp
			2	Daigen Maru No7	1937		1289brt, 66.8x10.9x5.6m, 1vte
			3	Hokoku Maru	1936		1274brt, 66.8x10.9x5.6m, 1vte, 1000hp
			4	Kwainei Maru	1920		1010brt, 60.9x9.3x5.7m, 1vte, 670hp
			5	Nissho Maru No12	1936		1199brt, 67.2x10.3x5.7m, 1vte, 810hp

APG		12	6	Tosho Maru	1936		1289brt, 66.8x10.9x5.6m, 1vte, 1000hp
			7	Giyu Maru	1938		877brt
			8	Hyakufuku Maru	1928		986brt
			9	Kiri Maru No8	1937		945brt
			10	Shinko Maru No1	1938		934brt
			11	Shosei Maru	1929		998brt
			12	Unkai Maru No10	1939		851brt
PR	Toba	1	1	Toba	1911		291t, 55.9x8.2x0.8m, 2b, 3vte, 1400hp, 15kts, 59p; 2x1-76/40
	Seta	4	2	Seta	1923		400t, 56.1x8.2x1.0m, 2b, 2vce, 2100hp, 16kts, 62p; 2x1-76/40
			3	Kataka	1923		
			4	Hira	1923		
			5	Hozu	1923		
	Atami	2	6	Atami	1929		249t, 46.3x6.3x0.9m, 2b, 2vce, 1300hp, 16.7kts, 77p; 1x1-76/23, 1x1-13.2/76
			7	Futami	1930		
	Kotaka	1	8	Kotaka	1930		63t, 30.5x4.9x0.6m, 2d, 540hp, 15kts
	Fushimi	1	9	Fushimi	1939		368t, 50.3x9.8x1.3m, 2b, 2gt, 2200hp, 17kts, 64p; 1x1-76/23, 1x2-25/60

## COASTAL FORCES

PT	CMB-55	1	1	No1149	1920		14t, 16.8x3.4x1.0m, 2pe, 1000hp, 40kts, 5p; 2-450TT, 1DCR
	ex-Chinese	1	2	unknown	1935		14t, 16.8x3.4x1.0m, 2pe, 1500hp, 38kts, 5p; 2-450TT
YPR	19m	48	1 - 48	No3537 etc	1936 - 1938		10t, 19.0x4.0x0.3m, 1pe(as), 500hp, 19kts; 100men
	15m	40	49 - 88	No1035 - 1038 etc	1938 - 1939	No picture	10t, 15.0x3.3x0.6m, 1-2pe, 120hp, 11kts; 1x1-12.7(3 units)

## AMPHIBIOUS SHIPS

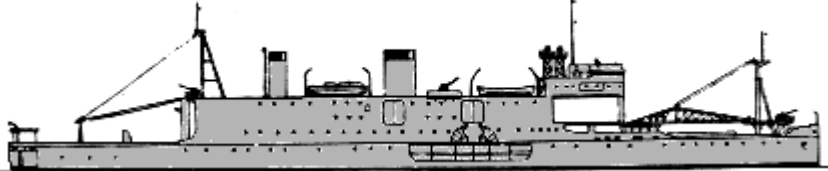
LAVPD	Sinshu Maru	1	1	Shinshu Maru	1935		11800t, 156.0x22.0x8.2m, b, 2gt, 8000hp, 19kts, 220p; 8x1-75/44, 20seaplanes (20 E7K+ E8N), 29 Daihatsu LC, 2200troops
LC	14m	~200	1 -	No5029	1935 -		20t, 14.6x3.4x0.8m, 1d, 60hp, 7.5kts, 5p; 70men or 1 7.5t tank

Daihatsu

200





etc

1939

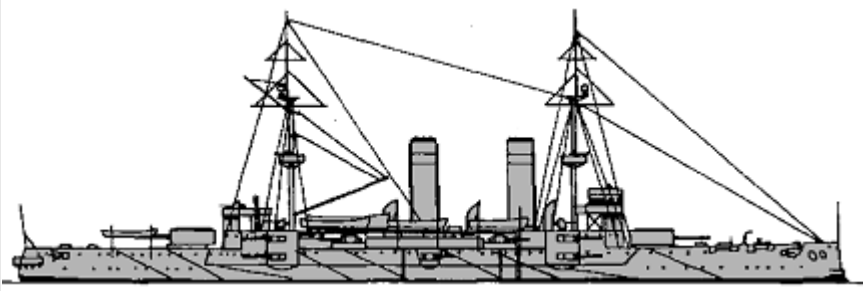
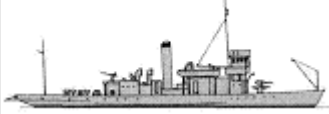
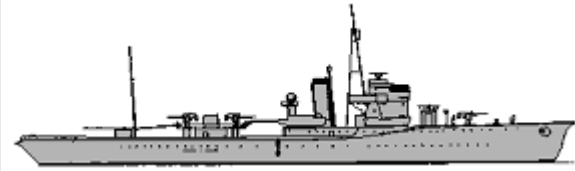
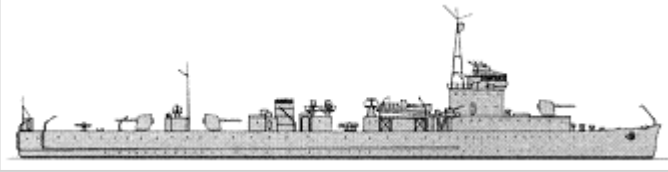
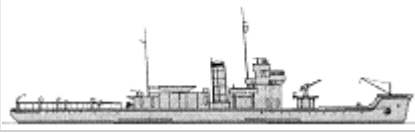

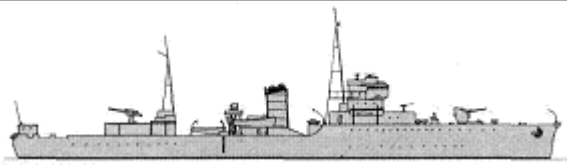
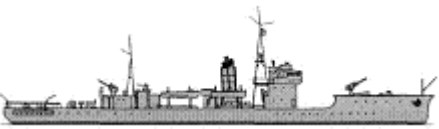
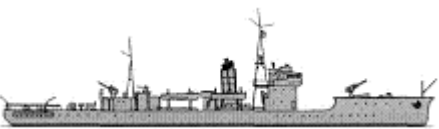
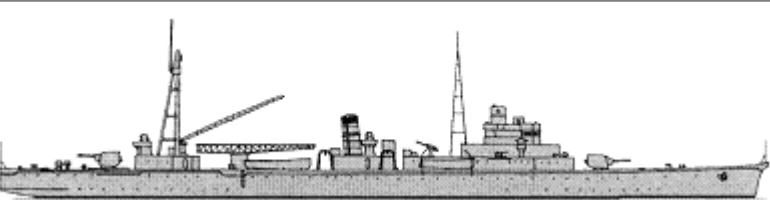
## MINE WARFARE

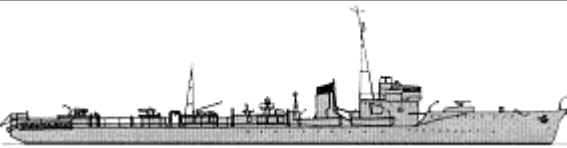
						10500t, 134.7x20.5x7.4m, 8b, 2vte, 9000hp, 16kts, 726p; HN 178belt, 76deck, 152turrets, 356CT; 4x1-152/40, 3x1-76/40, 2x1-40/62, 500mines	
ML	Natsushima	11	2	Toshima	1915		435t, 45.7x7.6x2.3m, 1b, 1vte, 600hp, 12.8kts, 40p; 2x1-76/40, 120mines, MS
			3	Kuroshima	1915		
			4	Ashizaki	1916		
			5	Katoku	1916		
			6	Kurokami	1917		
			7	Katashima	1917		
			8	Ento	1917		
			9	Enoshima	1919		
			10	Kurosaki	1921		
			11	Ninoshima	1920		
			12	Washizaki	1921		
						1900t, 84.0x11.6x3.1m, 2b, 2vte, 2000hp, 16kts, 2x1-120/45, 100mines	
						2408t, 107.5x11.8x3.2m, 3d, 3000hp, 17kts, 235p; 3x1-140/50, 2x1-47/30, 2x2-13.2/76, 300mines, 2DCT	
	Kamome	2	16	Kamome	1929		557t, 68.8x7.2x2.1m, 2b, 2vte, 2500hp, 19kts, 56p; 1x1-76/40, 1x1-13.2/76, 120mines
			17	Tsubame	1929		
						1384t, 93.5x10.7x2.8m, 2b, 2vte, 4800hp, 20kts, 150p; 2x1-120/45, 2x1-13.2/76,	

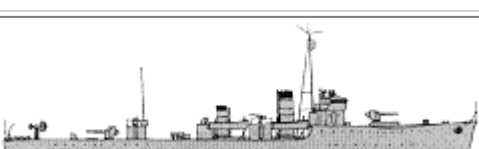
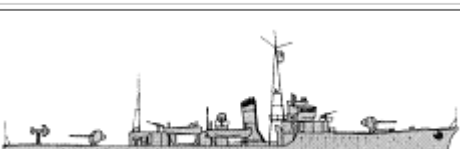
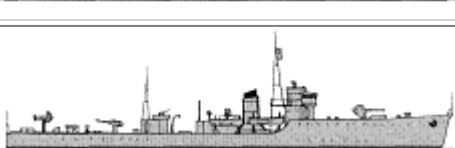
	Yaeyama	1	18	Yaeyama	1932		185mines
	Natsushima	2	19	Natsushima	1933		510t, 70.0x7.5x1.9m, 2d, 2300hp, 19kts, 74p; 2x1-76/40, 1x1-13.2/76, 120mines, MS
			20	Nasami	1934		
	Sarushima	1	21	Sarushima	1934		585t, 70.0x7.5x1.9m, 2d, 2100hp, 18kts; 2x1-76/40, 1x1-13.2/76, 120mines, MS
	Okinoshima	1	22	Okinoshima	1936		5000t, 124.5x15.7x5.5m, 4b, 2gt, 9000hp, 20kts, 445p; 2x2-140/50, 2x1-76/40, 2x2-13.2/76, 500mines, 1seaplane (1 E7K)
	Sokuten	3	23	Sokuten	1938		750t, 75.5x7.9x2.6m, 2d, 3600hp, 20kts, 100p; 1x2-40/62, 1x2-13.2/76, 120mines
			24	Shirakami	1939		
			25	Kyosai	1939		
	Hatsutaka	1	26	Hatsutaka	1939		1890t, 90.9x11.3x4.4m, 3b, 2gt, 6000hp, 20kts, 199p; 2x2-40/62, 2x2-13.2/76, 360mines
MS	W1	4	1	W1	1923		807t, 76.3x8.0x2.3m, 3b, 2vte, 4000hp, 20kts, 92p; 2x1-120/45, MS
			2	W2	1923		
			3	W3	1923		
			4	W4	1925		
	W5	2	5	W5	1929		826t, 77.0x8.2x2.2m, 3b, 2vte, 4000hp, 21kts, 87p; 2x1-120/45, 1x1-13.2/76, MS
			6	W6	1929		
	W13	4	7	W13	1933		800t, 74.0x8.2x2.1m, 2b, 2vte, 3200hp, 18kts, 98p; 2x1-120/45, 2x1-13.2/76, MS
			8	W14	1933		
			9	W15	1934		
			10	W16	1934		
	W17	2	11	W17	1936		707t, 72.5x7.9x2.5m, 2b, 2gt, 3200hp, 19kts, 98p; 2x1-120/45, 2x1-13.2/76, MS
			12	W18	1936		
	W7	6	13	W7	1938		750t, 72.5x7.9x2.0m, 2b, 2gt, 3850hp, 20kts, 88p; 3x1-120/45, 1x2-25/60, MS
			14	W8	1939		
15			W9	1939			
16			W10	1939			

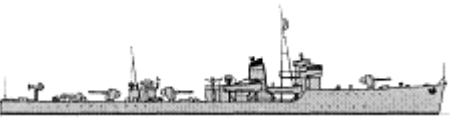
		17	W11	1939			
		18	W12	1939			
AMS	-	4	1	Takasago Maru	1921		275brt
			2	Tamasono Maru No1	1920		313brt
			3	Tamasono Maru No2	1920		316brt
			4	Tamasono Maru No3	1920		316brt

NAVAL AVIATION (*approximately, maximal number of delivered planes signed*)

Deck planes	F: 221 A4N1, 988 A5M1, A5M2a, A5M2b and A5M4 (delivery till 1941); DB: 163 D1A1, 428 D1A2 (delivery till 1940), 470 D3A1 (delivery till 1942);TB: 205 B4Y1 (delivery till 1940), 125 B5M1, 500 B5N1 (delivery till 1940);R: 20 C5M1, 30 C5M2 (delivery till 1940)
Seaplanes	R: 85 E4N2, 185 E7K1, 345 E7K2 (delivery till early 1941), 755 E8N1 and E8N2 (delivery till early 1940), 35 E9W1, 15 E10A1, 17 E11A1 (delivery till 1940)

[home](#)[World navies yesterday](#)[1940](#)

## Latvia 01 January 1940

### SUBMARINES

SS	Ronis	2	1	Ronis	1927		390/514t, 55.0x4.8x3.6m, 2d/em, 1300/700hp, 14/9kts, 27p, 50m; 1x1-75/35, (2+2x2)-450TT
			2	Spidola	1927		

### ESCORTS

PC	Virsaitis	1	1	Virsaitis	1917		539t, 59.3x7.4x2.2m, 2b,2vte, 1850hp, 16kts, 51p; 2x1-84/55, 2x1-47/44, 40m, MS
----	-----------	---	---	-----------	------	---	---

### OTHER FIGHTING SHIPS

ADV	-	1	1	Artillerists	1910	110t
-----	---	---	---	--------------	------	------

### MINE WARFARE SHIPS

MS	Viesturs	2	1	Viesturs	1926		310t, 48.9x6.5x1.5m, 2b,2vte, 750hp, 14kts, 39p; 1x1-75/35, 30m, MS
			2	Imanta	1926		

[home](#)

[World navies yesterday](#)

[1940](#)

## Lithuania 01 January 1940

### ESCORTS

PC	Prezidentas Smetona	1	1	Prezidentas Smetona	1917		535t, 59.3x7.3x2.2m, 2b,2vte, 1750hp, 16kts, 70p; 2x1-105/45, 30m, MS
----	---------------------	---	---	---------------------	------	--	---



© Ivan Gogin, 2011-15





[home](#)[World navies yesterday](#)[1940](#)

## Manchukuo 01 January 1940

### ESCORTS

FS	Hai Wei	1	1	Hai Wei	1917		1080t, 85.6x7.7x2.3m, 4b,2gt, 7000hp, 15kts, 110p; 2x1-120/40, 3x2-13.2, 2DCT
PC	Hai Feng	2	1	Hai Feng	1933		220t, 43.6x6.1x1.5m, 2d, 800hp, 14kts; 2x1-76/40, 2x1-12.7, 2DCT
			2	Hai Lung	1933		

### OTHER FIGHTING SHIPS

PGR	Li Sui	1	1	Li Sui	1904		280t, 50.1x8.0x0.9m, 2b,2vte, 1300hp, 13kts, 50p; 2x1-57/40
	Shun Tien	2	2	Shun Tien	1934		270t, 55.8x8.8x0.9m, 2d, 680hp, 12.5kts, 70p; (1x2+1x1)-120/45, 2x1-70/12mrt, 3x2-13.2, 80m
			3	Yang Min	1934		
	Chin Yen	2	4	Chin Yen	1935		290t, 59.4x8.8x0.9m, 2d, 800hp, 13kts, 70p; (1x2+1x1)-120/45, 2x1-70/12mrt, 3x2-13.2, 80m
5			Ting Pien	1935			
APGR	-	4	1	Kiang Ping	1897		250t; 1x1-76/40
			2	Kiang Chin	1903		250t; 1x1-76/40
			3	Kiang An	1897		250t; 1x1-76/40
			4	Li Tsy	1897		250t; 1x1-76/40

### COASTAL FORCES

YP	Hai Kuang	4	1-4	Hai Kuang, Hai Jui, Hai Jung, Hai Hua	1933	No picture	45t, 25.9x3.9x0.9m, 1d, 240hp, 12kts; 1x1-57/40
----	-----------	---	-----	---------------------------------------	------	------------	---

YPR	Shun Tsu	1	1	Shun Tsu	1919	No picture	15t, 18.3x3.0x0.7m, 2pe, 100hp, 15kts, 14p; 1x1-37/23
	Ta Tung	2	2,3	Ta Tung, Li Min	1933	No picture	56t, 30.5x4.9x0.8m, 2d, 240hp, 10.5kts, 20p; 1x1-57/40
	On Min	6	4-9	On Min, Hai Min, Hui Min, Pu Min, Wen Min, Wan Min	1933	No picture	15t, 18.2x3.4x0.8m, 1d, 80hp, 11kts
	Wei Ming	4	10-13	Wei Ming, Hsiao Chiang, Chin Min, Chin Chang	1935	No picture	30t, 18kts; 1x1-37/32
	Shuan An	2	14,15	Shuan An, Shuan Kai	1935	No picture	42t, 25.8x3.9x0.9m, 1d, 12kts; 1x1-37/32
	Din Shun	6	16-21	Din Shun, Tsing Yun, Chang Yun, Kiang Yun, Sun Yun, Yun Shun	1938-1939	No picture	10t, 16kts

© Ivan Gogin, 2011-15

[home](#)[World navies yesterday](#)[1940](#)

## Mexico 01 January 1940

### CRUISERS

CLP	Progreso	1	1	Progreso	1907		1700t, 70.1x10.3x3.0m, 1vte, 1400hp, 13kts, 140p; 4x1-57/40, troops
-----	----------	---	---	----------	------	--	---

### ESCORTS

PC	G20	10	1	G20	1935		180t, 46.6x5.0x1.6m, 2d, 3000hp, 26kts, 21p; 1x2-25/60, 2x2-13.2
			2	G21	1935		
			3	G22	1935		
			4	G23	1936		
			5	G24	1936		
			6	G25	1936		
			7	G26	1936		
			8	G27	1936		
			9	G28	1936		
			10	G29	1936		
TL	Salinas	4	1	Salinas	1917	No picture	486t, 40.5x7.1x4.1m, 1b,1vte, 557hp, 7kts, 26p; 1x1-57/40(2,3), 2x1-40/39(2,3), 1x1-25/60(1,4), 1x1-13.2(1,4)
			2	Mazatlan	1917		
			3	Tampico	1917		
			4	Vera Cruz	1917		

### OTHER FIGHTING SHIPS

	Nicholas Bravo	1	1	Nicholas Bravo	1904		1493t, 73.8x10.4x3.0m, 2vte, 2565hp, 17kts, 116p; 2x1-102/40, 6x1-57/40, 1-356TT
--	----------------	---	---	----------------	------	--	--

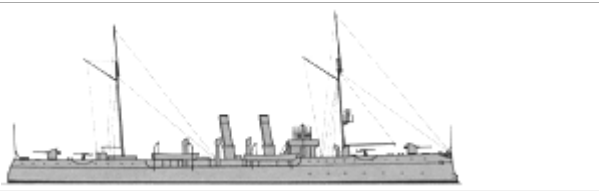
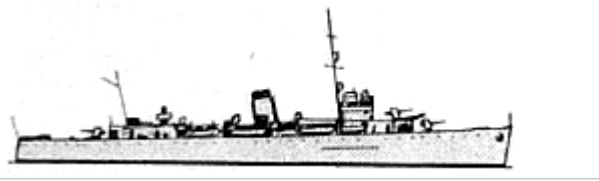
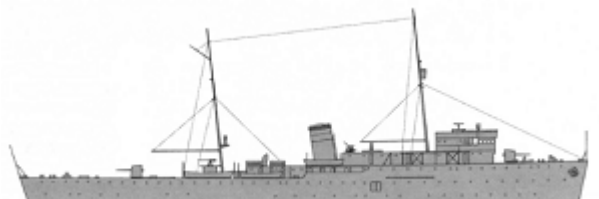
							
PG	Guanajuato	3	2	Guanajuato	1936		1950t, 80.4x11.5x3.1m, 2b,2gt, 5000hp, 20kts, 140p; 3x1-102/45, 2x2-25/60, 2x2-13.2; 230troops, 40horses
			3	Querétaro	1936		
			4	Potosi	1936		
	Durango	1	5	Durango	1936		2000t, 92.4x12.2x3.1m, 2b,2gt, 6500hp, 20kts, 141p; 2x1-102/45, 2x1-57/40, 2x2-25/60, 2x2-13.2; 490troops, 80horses

### COASTAL FORCES

PS	18 de Mayo	2	1, 2	18 de Mayo, Yaqui	1917 - 1918		85t, 33.5x4.5x1.7m, 3pe, 660hp, 18kts, 27p; 1x1-76/23, 1DCT
----	------------	---	------	-------------------	-------------	---	---

© Ivan Gogin, 2011-15

[home](#)[World navies yesterday](#)[1940](#)

# NETHERLANDS 01 January 1940

## CAPITAL SHIPS

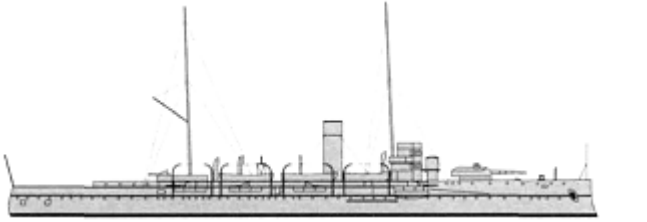
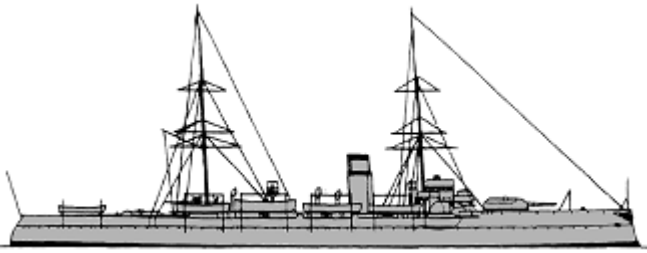
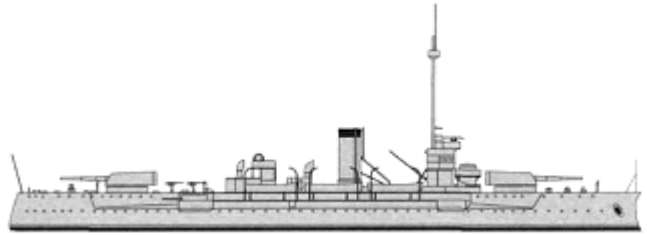

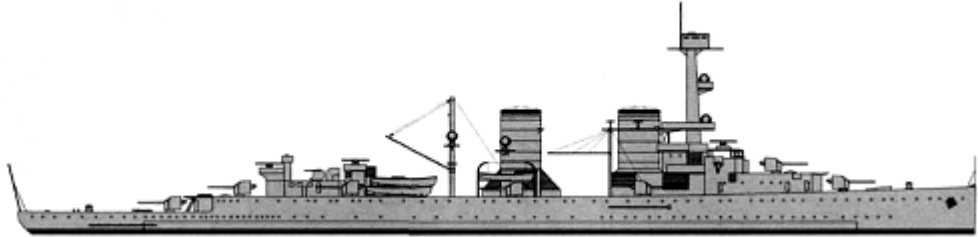

	Koningin Regentes	1	1	Vliereede	1904		5084t, 96.6x15.2x6.8m, 6b,2vte, 6500hp, 16.5kts, 340p; 152belt, 51deck, 102turrets, 246CT; 1x1-240/40, 4x1-150/40, 4x1-75/55, 3-450TT, 2seaplanes (C.VIIW)
BC	Jacob van Heemskerck	1	2	Ijmuiden	1908		4920t, 98.0x15.2x5.7m, 8b,2vte, 6400hp, 16.5kts, 340p; 152belt, 51deck, 102turrets, 194CT; 2x1-240/40, 2x1-40/56
	De Zeven Provinciën	1	3	Soerabaja	1910		6510t, 103.5x17.1x6.2m, 3b,2vte, 7500hp, 16kts, 447p; 150belt, 50deck, 250turrets, 200CT; 2x1-283/43, 2x1-150/40, 2x1-75/55, 2x1-40/56, 3x2-12.7

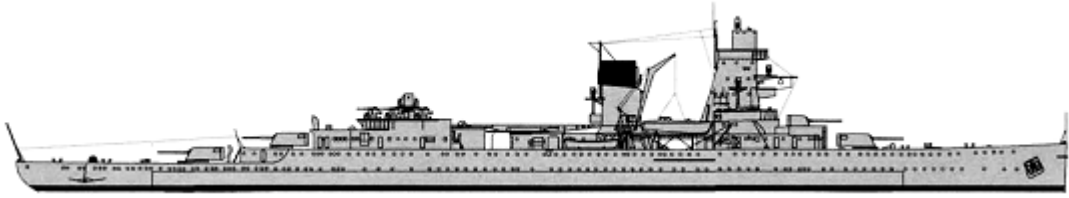
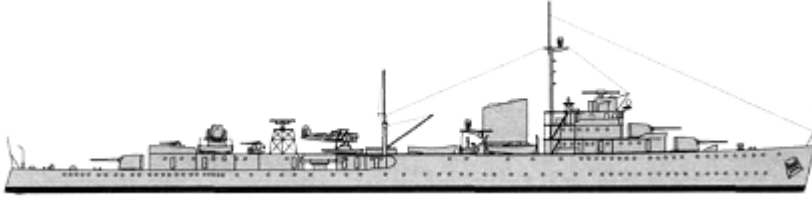
## CRUISERS

		1	Java	1925		8208t, 155.3x16.0x5.5m, 8b,3gt, 65000(1)-82000(2)hp, 30kts, 480p; 75belt, 25deck, 100turrets, 125CT; 10x1-150/50, 4x2-40/56(1), 6x1-40/56(2), 6x1-12.7, 12m, 2seaplanes (C.VIIW)
	Java	2	Sumatra	1926		

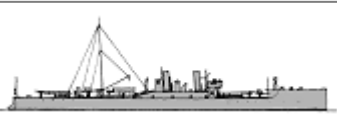

CL	De Ruyter	1	3	De Ruyter	1936		7548t, 170.8x15.7x5.1m, 6b,2gt, 66000hp, 32kts, 480p; 50belt, 30deck, 100turrets, 30CT; (3x2+1x1)-150/50, 5x2-40/56, 4x2-12.7, 2seaplanes (C.XIW)
	Tromp	1	4	Tromp	1938		4817t, 132.0x12.4x4.6m, 4b,2gt, 56000hp, 33.5kts, 480p; (16+30)belt, 25deck, 25turrets, 12CT; 3x2-150/50, 2x2-40/56, 2x2-12.7, 2x3-533TT, 1seaplane (C.XIW)

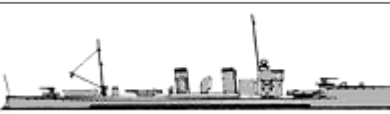
## TORPEDO SHIPS

DD	Van Ghent	4	1	Van Ghent	1928		1640t, 98.2x9.5x3.0m, 3b,2gt, 31000hp, 36kts, 129p; 4x1-120/50, 2x1-75/55, 4x1-12.7, 2x3-533TT, 4DCT, 32m, 1seaplane (C.VIIW)
			2	Evertsen	1928		
			3	Kortenaer	1928		
			4	Piet Hein	1928		
	Van Galen	4	5	Van Galen	1929		1650t, 98.2x9.5x3.0m, 3b,2gt, 31000hp, 36kts, 120p; 4x1-120/50, 1x1-75/55, 4x1-40/39, 4x1-12.7, 2x3-533TT, 4DCT, 1seaplane (C.VIIW)
			6	Witte de With	1930		
			7	Banckert	1930		
			8	Van Nes	1931		
TB	G13	3	1	G13	1914		230t, 49.5ppx5.3x1.5m, 2b,2vte, 2600hp, 25kts, 27p; 2x1-75/30, 2x1-12.7, 3x1-450TT
			2	G15	1914		
			3	G16	1914		
	Z5	3	4	Z6	1917		310t, 58.5ppx6.1x1.7m, 3b,2vte, 5500hp, 27kts, 46p; 2x1-75/30, 2x1-12.7, (1x2+2x1)-450TT
			5	Z7	1916		
			6	Z8	1916		
Z1	1	7	Z3	1920		322t, 62.6x6.2x1.9m, 3b,2t, 5500hp, 27kts, 46p; 2x1-75/30, 2x1-12.7, (1x2+2x1)-450TT	

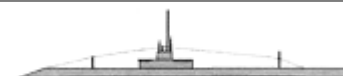
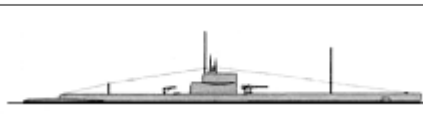
## SUBMARINES

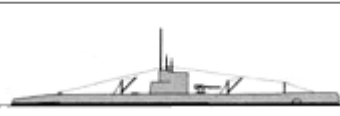
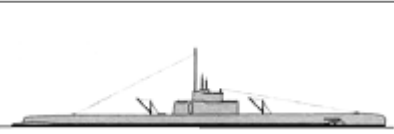
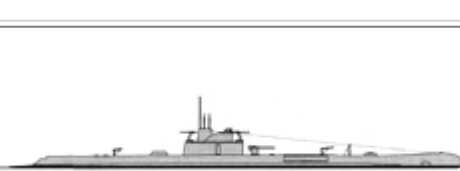
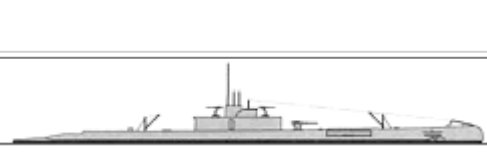
O8	1	1	O8	1915		364/434t, 45.8x4.7x3.8m, 2d/em, 480/620hp, 13/11kts, 22p, 50m; 1x1-37/45, 4-450TT
K V	1	2	K VII	1922		569/649t, 57.3x5.6x3.8m, 2d/em, 1200/400hp, 13.5/8kts, 31p, 40m; 1x1-75/55, 1x1-12.7, (4+1x2)-450TT
K VIII	3	3	K VIII	1922		583/810t, 64.4x5.6x3.6m, 2d/em, 1800(11)-1550(12,13)/400hp, 16(11)-15(12,13)/8kts, 31p, 50m; 1x1-88/45, 1x1-12.7, 4-450TT
		4	K IX	1923		
		5	K X	1923		
		6	K XI	1925		

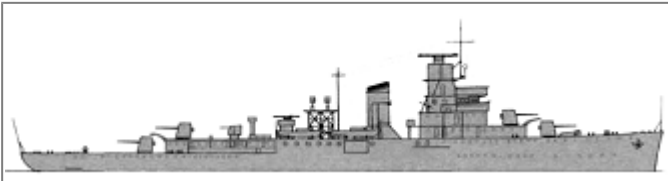

K XI	3	7	K XII	1925		688/828t, 66.7x6.2x3.8m, 2d/em, 2400/654hp, 17/8kts, 31p, 60m; 1x1-88/45, 1x1-12.7, 2-533TT, 4-450TT
		8	K XIII	1926		
O9	3	9	O9	1926		526/656t, 54.7x5.7x3.5m, 2d/em, 900/500hp, 12/8kts, 29p, 60m; 1x1-88/45, 1x1-12.7, 2-533TT, 3-450TT
		10	O10	1926		
		11	O11	1926		
O12	4	12	O12	1931		610/754t, 60.4x6.8x3.6m, 2d/em, 1800/620hp, 16/8kts, 31p, 60m; 1x1-12.7, 5-533TT
		13	O13	1931		
		14	O14	1932		
		15	O15	1932		
K XIV	5	16	K XIV	1933		865/1045t, 73.6x6.5x3.9m, 2d/em, 3200/960hp, 17/9kts, 38p, 80m; 1x1-88/45, 2x1-40/40, (6+1x2)-533TT
		17	K XV	1933		
		18	K XVI	1934		
		19	K XVII	1933		
		20	K XVIII	1934		
O16	1	21	O16	1936		984/1194t, 76.5x6.6x4.0m, 2d/em, 3200/920hp, 18/9kts, 36p, 80m; 1x1-88/45, 2x1-40/40, (6+1x2)-533TT
O19	2	22	O19	1939		1116/1561t, 80.9x7.4x3.9m, 2d/em, 5300/1000hp, 19.5/9kts, 40p, 100m; 1x1-88/45, 2x1-40/40, 1x1-12.7, 8-533TT, 40m
		23	O20	1939		

## ESCORTS

SL	Van Kinsbergen	1	1	Van Kinsbergen	1939		2388t, 103.2x11.6x3.1m, 2b,2gt, 17000hp, 25.5kts, 145p; 13belt, 20deck, 20CT; 4x1-120/50, 2x1-75/55, 2x2-40/56, 2x2-12.7
PC	Albatros	1	1	Albatros	1912	No picture	892t, 50.0ppx9.4x3.3m, 1vte, 1140hp, 12kts, 47p; 2x1-37/45
	Aldebaran	1	2	Aldebaran	1913	No picture	892t, 53.3ppx8.2x3.5m, 1vte, 800hp, 12kts, 45p; 2x1-37/45
	Bellatrix	3	3	Bellatrix	1914	No picture	773t, 53.3ppx9.0x3.0m, 1vte, 800hp, 12kts, 45p; 1x1-75/55(3), 2x1-37/45(4,5)
			4	Canopus	1915		
			5	Deneb	1915		
	Eridanus	1	6	Eridanus	1918	No picture	996t, 56.5ppx9.0x3.2m, 1vte, 800hp, 12kts, 44p; 1x1-75/55
	Gemma	1	7	Gemma	1918	No picture	845t, 53.3ppx9.0x3.2m, 1vte, 800hp, 12kts, 44p; 1x1-75/55
	Sirius	2	8	Sirius	1922	No picture	1015t, 55.6ppx9.5x3.3m, 1vte, 900hp, 12.5kts, 50p; 1x1-75/55
			9	Wega	1922		
	Fomalhaut	1	10	Fomalhaut	1923	No picture	1001t, 56.9ppx9.5x3.4m, 1vte, 855hp, 12.5kts, 55p; 2x1-37/45
	Merel	3	11	Merel	1928	No picture	592(12)-624(13,14)t, 46.4(12)-47.8(13,14)ppx8.4x2.8m, 2b,1vte, 525hp, 12kts, 40p; 1x1-75/55
			12	Reiger	1931		
			13	Fazant	1931		
	Arend	2	14	Arend	1929	No picture	1011t, 71.9x9.0x2.8m, 2b,2vte, 3350hp, 18kts, 61p; 2x1-75/55, 1seaplane (C.VIIW)

		15	Valk	1929		
Z5	1	16	Z5	1917		310t, 58.5ppx6.1x1.7m, 2b,2vte, 3000hp, 22kts, 34p; 2x1-75/30, 2x1-12.7

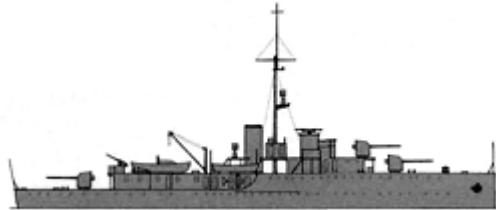
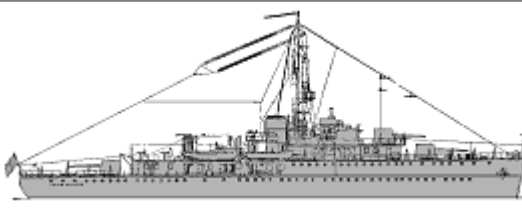
## OTHER FIGHTING SHIPS

PG	Brinio	1	Brinio	1914		634(1)-573(2)-581(3)t, 52.7x8.5x2.8m, 2d, 1500hp, 14kts, 52p; 55belt, 17deck, 50shields, 50CT; 4x1-105/50, 2x1-12.7	
		2	Friso	1915			
		3	Gruno	1915			
	Flores	4	Flores	1926		1793t, 76.4x11.5x3.6m, 4b,2vte, 2000hp, 15kts, 132p; 50slopes, 25deck, 80shields, 50CT; 3x1-150/50, 1x1-75/55, 2x2-12.7, 1seaplane (C.VIIW)	
		5	Soemba	1926			
		Johan Maurits van Nassau	1	6	Johan Maurits van Nassau	1933	
PR	K1	1	1	K2 Christiaan Cornelis	1905	No picture	47t, 30.0x3.6x1.7m, 1b,1vte, 560hp, 18.7kts, 12p; 1x1-37/23
	Wodan	2	Braga	1879		280t, 27.8x8.2x2.3m, 2b,1vce, 171hp, 8.3kts, 34p; 1x1-120/40(3,5), 1x1-75/55(4), 2x1-37/23, 1x5-37/20	
		3	Freyr	1877			
		4	Tyr	1878			
		5	Hefring (TS)	1880			



## COASTAL FORCES



PT	TM III	1	1	TM III	1938	No picture	13t, 18.6x3.8x1.0m, 2pe, 1260hp, 32kts, 6p; 2-450TT
	TM51	1	2	TM51	1939		37t, 21.3x6.1x1.4m, 3pe, 3300hp, 40kts, 10p; 2x1-20/80, 2-450TT, 2DCR
YP	P1	4	1 - 4	P1 - 4	1939		23t, 18.9ppx5.6x1.2m, 1d, 165hp, 12.5kts

## MINE WARFARE SHIPS

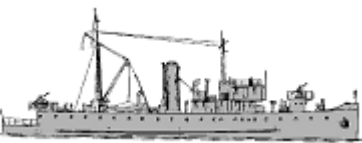
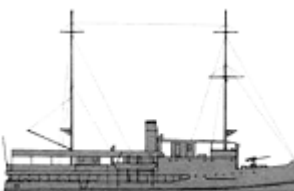
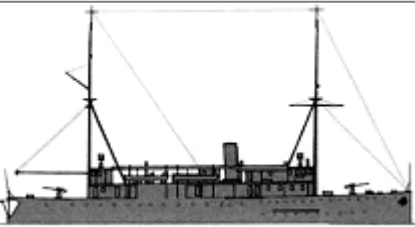
Wodan	1	Balder	1879		280t, 27.8x8.2x2.3m, 2b,1vce, 171hp, 8.3kts, 34p; 1x1-150/40(6), 2x1-37/23, 1x5-37/20, ~20m
	2	Thor	1877		
	3	Vidar	1879		
	4	Hadda	1880		
	5	Bulgia	1884		

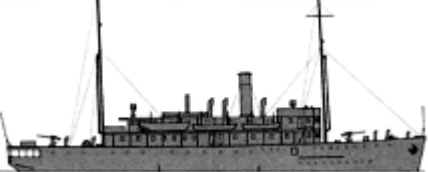
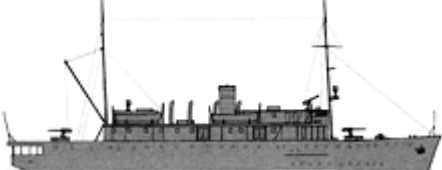
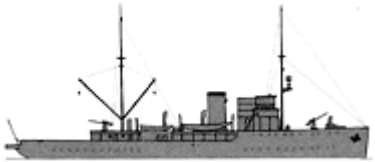
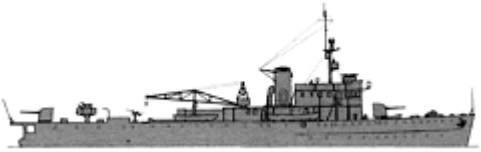

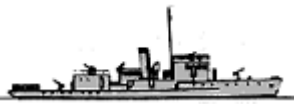
ML	Hydra	2	6	Hydra	1912		670t, 49.7x9.0x2.8m, 2b,2vte, 900hp, 11kts, 59p; 3x1-75/55, 2x1-12.7, 70m
			7	Medusa	1911		
	Van Meerlant	2	8	Van Meerlant	1922		748t, 54.8ppx8.7x3.2m, 2b,2vte, 1000hp, 13kts, 60p; 3x1-75/55, 2x1-12.7, 60m
			9	Douwe Aukes	1922		
	Pro Patria	1	10	Pro Patria	1923		612t, 47.0ppx8.6x2.3m, 2b,1vte, 650hp, 10kts, 61p; 1x1-75/40, 2x1-12.7, 60m
	Krakatau	1	11	Krakatau	1924		1160t, 65.0ppx10.0x3.2m, 2b,1vte, 2500hp, 15.5kts, 105p; 2x1-75/40, 4x1-12.7, 150m
	Nautilus	1	12	Nautilus	1930		951t, 58.7x9.5x3.5m, 3b,2vte, 1350hp, 15kts, 57p; 2x1-75/55, 1x1-37/45, 2x1-12.7, 60m
	Rigel	1	13	Rigel	1931		1631t, 74.0x11.0x3.1m, 2b,2vte, 1400hp, 12.7kts, 67p; 2x1-75/40, 2x1-12.7, 150m
	Prins van Oranje	2	14	Prins van Oranje	1932		1600t, 70.0x11.0x3.3m, 2b,2vte, 1750hp, 15kts, 121p; 2x1-75/55, 2x1-40/39, 2x1-12.7, 150m
			15	Gouden Leeuw	1932		
Jan van Brakel	1	16	Jan van Brakel	1936		955t, 58.7x10.0x3.3m, 2b,2vte, 1600hp, 15kts, 65p; 2x1-75/55, 1x1-40/39, 2x2-12.7, 60m	
Willem van der Zaan	1	17	Willem van der Zaan	1939		1407t, 75.2x11.2x3.3m, 2b,2vte, 2200hp, 15.5kts, 92p; 2x1-120/50, 2x2-40/56, 2x2-12.7, 120m, 1seaplane (C.XIW)	
Nr.1	4	1	M1	1918	No picture	238(1)-205(2)-230(3,4)t, 30.5(1)-29.7(2)-29.8(3,4)x 7.0(1)-6.7(2)-6.4(3,4)x 2.8(1)-3.1(2)-2.5(3,4)m, 1b,1vte, 500(1,2)-450(3,4)hp, 9.5(1)-10(2-4)kts, 16p; 1x1-12.7, MS	
		2	M2	1918			

MS	A	4	3	M3	1918		179t, 42.8x6.0x1.5m, 1b,1vte, 700hp, 14.5kts, 38p; 2x1-12.7, MS
			4	M4	1918		
			5	A	1930		
			6	B	1930		
	Jan van Amstel	7	7	C	1930		585t, 56.8x7.8x2.0m, 2b,2vte, 1600hp, 15kts, 45p; 1x1-75/55, 2x2-12.7, 40m, MS
			8	D	1930		
			9	Jan van Amstel	1937		
			10	Pieter de Bitter	1937		
			11	Abraham Crijnssen	1937		
			12	Eland Dubois	1937		
			13	Pieter Florisz	1937		
	Alor	6	14	Jan van Gelder	1937		145t, 31.6x5.5x1.8m, 1d, 300hp, 12kts, 18p; 2x1-37/23, MS
			15	Abraham van der Hulst	1937		
			16	Alor	1938		
			17	Aroe	1938		
18			Bantam	1938			
19			Bogor	1938			
AMS -	11	1	Alkmaar	1914		310t	
		2	Aneta	1916		261t	
		3	Azimuth	1911		229t	
		4	En Avant	1911		264t	
		5	Ewald	1912		209t	
		6	Hollandia	1917		220t	
		7	Maria R. Ommering	1914		216t	
		8	Noordsvaarder	1897		179t	
		9	Rotterdam	1916		231t	
		10	Walrus	1929		372t	
		11	Witte Zee			226t	

## NAVAL AVIATION (approximately, maximal number of delivered planes signed)

Seaplanes

R: 30 C.VIIW, 15 C.XIW; P: 36 Do 24K-1 (delivery till 1940)

© Ivan Gogin, 2011-14

[home](#)[World navies yesterday](#)[1940](#)

## NEW ZEALAND 01 January 1940

### CRUISERS

AMC	-	1	1	Monowai	1924		10852brt, 158.2x19.3x7.9m, 2vqe, 19kts; 8x1-152/45, 2x1-76/45
-----	---	---	---	---------	------	--	---

### MINE WARFARE

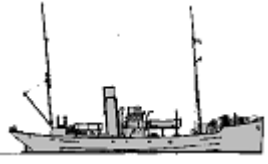
AMS	-	1	1	Uki	1923		545t; 1x1-76/40
TL	Castle	1	1	James Cosgrove	1918		547t, 40.8x7.2x2.8m, 1b, 1vte, 480hp, 10.5kts, ?p; 1x1-76/40, MS
	Strath	1	2	Thomas Currell	1919		429t, 37.5x6.8x2.8m, 1b, 1vte, 430hp, 10kts, ?p; 1x1-76/40, 1DCT, MS
	-	1	3	Humphrey	1917		207t

© Ivan Gogin, 2010-15



[home](#)[World navies yesterday](#)[1940](#)



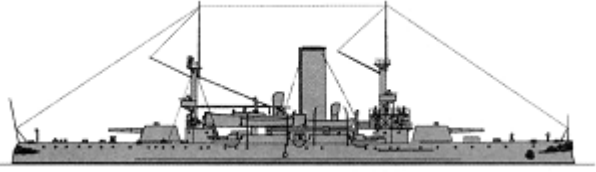
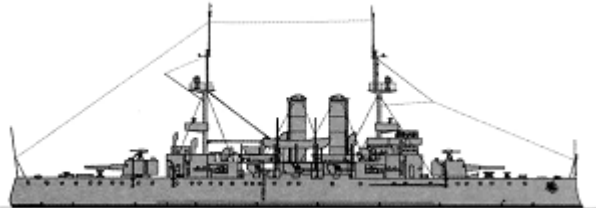

# NORWAY 01 January 1940

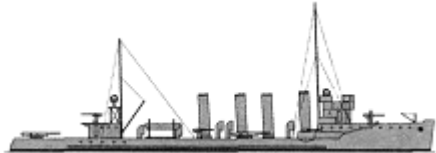
## CAPITAL SHIPS

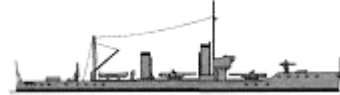
BC	Harald Haarfagre	1	Harald Haarfagre	1898		3858t, 92.7x14.8x5.4m, 3b, 2vte, 4000hp, 16.9kts, 245p; h: 178belt, n: 51deck, 203turrets, 152CT; 2x1-209/44, 6x1-120/44, 6x1-76/40, 2x1-76/28, 2x1-47/46, 6x1-37/45, 2x1-20/70, 2x1-12.7, 2-450TT
		2	Tordenskjold	1898		
	Norge	3	Norge	1901		4166t, 94.6x15.4x5.4m, 6b, 2vte, 4500hp, 16.5kts, 266p; 152belt, n: 51deck, 203turrets, 152CT; 2x1-209/44, 6x1-149/46, 8x1-76/40, 2x1-76/28, 6x1-47/46, 2x1-20/70, 2x1-12.7, 2-450TT
		4	Eidsvold	1901		

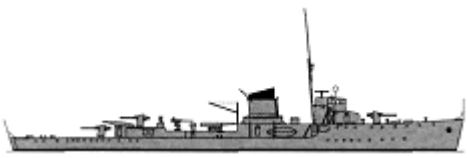
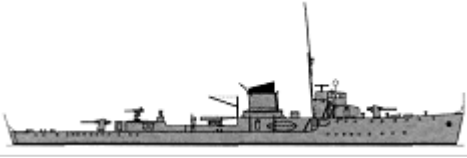
## TORPEDO SHIPS





DD	Draug	1	Draug	1907		578(1, 2)-597(3)t, 69.2x7.3x2.9m, 4b, 2vte(1, 2)-2t(3), 7500(1, 2)-8000(3)hp, 26.5(1)-27(2)-27.4(3)kts, 76p; 6x1-76/40, 1x1-12.7, 3x1-450TT
		2	Troll	1912		
		3	Garm	1914		
	Storm	1	Storm	1898		107t, 39.9x4.8x2.2m, 2b, 1vte, 1100hp, 21kts, 23p; 2x1-37/45, 2x1-450TT
		2	Brand	1898		
	Laks	3	Laks	1900		107t, 38.5x4.8x2.2m, 2b, 1vte, 1150hp, 21kts, 23p; 2x1-37/45, 2x1-450TT
		4	Sild	1900		
		5	Sæl	1901		
		6	Skrei	1901		
	Trygg	7	Trygg	1920		256t, 53.0x5.5x2.0m, 2b, 2vte, 3500hp, 25(9, 10)-24(11)kts, 33p; 1x1-76/28, 1x1-20/70, 2x2-450TT, 2DCR, mines
		8	Snøgg	1921		
		9	Stegg	1923		

TB	Sleipner	3	10	Sleipner	1937		708t, 74.3x7.8x2.1m, 3b, 2gt, 12500hp, 30kts, 75p; 3x1-100/40, 1x1-40/56, 2x1-12.7(10, 11), 1x2-533TT(10, 11), 2x2-533TT(12), 4DCT, 2DCR, 24mines
			11	Æger	1938		
			12	Gyller	1939		
	Odin	1	13	Odin	1939		719t, 76.0x7.8x2.1m, 3b, 2gt, 12500hp, 30kts, 75p; 2x1-100/40, 1x1-40/56, 2x1-12.7/90, 1x2-533TT, 4DCT, 2DCR, 24mines
	Ørn	2	14, 15	Ørn, Ravn	1905		73t, 34.5x4.4x1.6m, 2b, 1vte, 850hp, 23kts, 16p; 2x1-37/45, (1+1x1)-450TT
Grib	3	16 - 18	Grib, Jo, Lom	1906		74t, 36.2x4.5x1.9m, 2b, 1vte, 1000hp, 23kts, 16p; 2x1-37/45(16, 18), 1x1-37/45(17), 1x1-12.7(17), (1+1x1)-450TT	
Teist	3	19	Teist	1908		103(1, 2)-108(3)t, 41.1x4.7x2.3(1, 2)-2.4(3), 2b, 1vte, 1700hp, 25kts, 21p; 1x1-76/28(3), 2x1-47/46(1, 2), (1+2x1)-450TT(1, 2), (1+1x1)-450TT(3)	
		20	Skarv	1908			
		21	Kjell	1913			

## SUBMARINES





SS	A2	3	1	A2	1914		268/342t, 46.5x4.8x2.7m, 2d/em, 700/380hp, 14.5/9kts, 17p, 50m; 3-450TT
			2	A3	1914		
			3	A4	1914		
	B1	6	4	B1	1923		/545t, 51.0x5.3x3.5m, 2d/em, 900/700hp, 14.5/10.5kts, 23p, 60m; 1x1-76/28, 4-450TT
			5	B2	1924		
			6	B3	1926		
			7	B4	1927		
			8	B5	1929		
			9	B6	1930		

## ESCORTS

PS (FPV)	Fridtjof Nansen	1	1	Fridtjof Nansen	1931		1545t, 73.0x10.6x5.0m, 2b, 2vte, 2000hp, 15kts, 67p; 2x1-102/40, 2x1-47/46, 1seaplane (MF.11)
	Nordkapp	2	2	Nordkapp	1937	No picture	275t, 39.8x6.6x2.3m, 2de, 1em, 830hp, 13.7kts, 22p; 1x1-47/46, MS
			3	Senja	1937		
	-	2	4	Michael Sars	1900		226t
			5	Heimdals	1892		640t
PC	Lyn	2	1, 2	Lyn, Blink	1896		64t, 34.5x3.8x1.8m, 2b, 1vte, 650hp, 19kts, 21p; 2x1-37/45, MS
	Djerv	3	3 - 5	Djerv, Kvikk, Dristig	1897 - 1898		66t, 34.5x3.8x1.7m, 2b, 1vte, 650hp, 19kts, 21p; 2x1-37/45, MS
	Hvass	2	6, 7	Hvass, Kjæk	1901		74t, 34.1x4.4x1.6m, 2b, 2vte, 650hp, 19kts, 16p; 2x1-37/45, MS

Hauk	2	8, 9	Hauk, Falk	1904		73t, 34.9x4.4x1.6m, 2b, 2vte, 750hp, 20kts, 16p; 2x1-37/45, MS
-	1	10	Hval IV	1929		248t

## MINE WARFARE

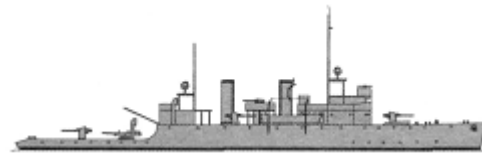
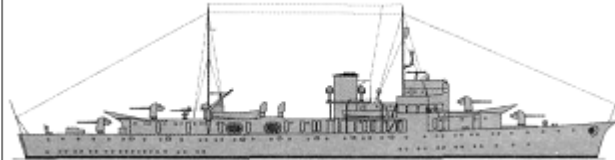
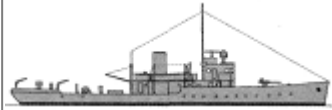
ML	Vale	2	1	Vale	1874		250t, 27.3x7.9x2.2m, 2b, 2vte, 200hp, 8kts, 38p; 1x1-120/44, 1x1-37/45, 50mines
			2	Uller	1877		
	Brage	2	3	Brage	1879		270t, 28.9x7.9x2.2m, 2b, 2vte, 220hp, 8.5kts, 38p; 1x1-149/46, 1x1-47/46, 1x1-37/45, 50mines
			4	Nor	1879		
	Vidar	1	5	Vidar	1882		270t, 28.9x7.9x2.2m, 2b, 2vte, 330hp, 9.5kts, 38p; 1x1-149/46, 1x1-47/46, 1x1-37/45, 50mines
	Gor	2	6	Gor	1885		290(6)-278(7)t, 31.3x8.0x2.2m, 420hp, 10.5kts; 1x1-120/44, 1x1-76/28(1), 1x1-4746(2), 55mines
			7	Tyr	1887		
	Frøya	1	8	Frøya	1917		755t, 75.6x8.2x2.8m, 2b, 2vte, 7000hp, 21.8kts, 78p; 4x1-102/40, 1x1-76/28, 1x2-450TT, 180mines
	Glommen	2	9	Glommen	1917	No picture	380t, 42.0x8.5x2.1m, 1b, 1vte, 170hp, 9.9kts, 35p; 2x1-76/28, 120mines
			10	Laugen	1918		
	Olaf Tryggvason	1	11	Olaf Tryggvason	1934		1860t, 97.3x11.5x3.6m, 3b, 2gt/2de, 2em(2), 6000/1400hp, 21kts, 191p; 4x1-120/44, 1x1-76/51, 2x1-40/56, 2x1-12.7, 2x2-450TT, 280mines
MS	Otra	1	1	Otra	1939		370t, 52.1x7.1x2.0m, 1b, 2vte, 900hp, 13.5kts, 25p; 1x1-40/56, 2x1-20/70, 2x1-12.7, MS, mines
	-	1	2	Alcmaria	1916		148t

УВЛАЖНЯЕТ

[home](#)[World navies yesterday](#)[1940](#)

## Paraguay 01 January 1940

### ESCORTS

APC	-	2	1	Capitán Cabral	1907	206t; 1x1-76/40
			2	Tacuari	1910	150t; 2x1-76/50, 2x1-76/40

### OTHER FIGHTING SHIPS

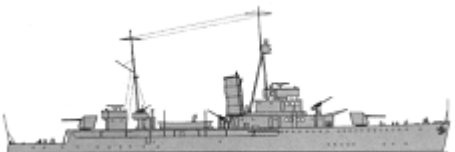
PGR	Paraguay	2	1	Paraguay	1931		835t, 71.2x10.7x2.9m, 2b,2gt, 3800hp, 17kts, 86p; 13belt, 8deck, 10turrets, 19CT; 2x2-120/50, 3x1-76/40, 2x1-40/39, 6m
			2	Humaitá	1931		

УВЛАЖНЯЕТ

© Ivan Gogin, 2011-15



[home](#)[World navies yesterday](#)[1940](#)

## Peru 01 January 1940

### CRUISERS

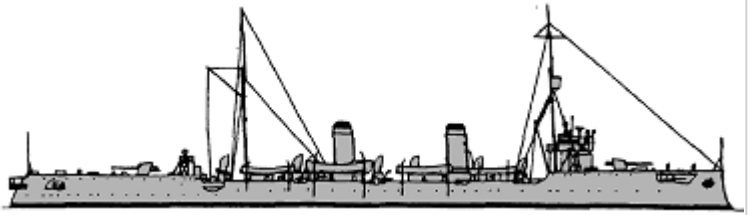
CL	Almirante Grau	1	Almirante Grau	1907		4877t, 115.8x12.3x4.3m, 8b,2vte, 14000hp, 23.5kts, 320p; 38belt, 38deck, 76shields, 76CT; 2x1-152/50, 6x1-76/40, 2x2-13.2, 2-450TT
		2	Coronel Bolnesi	1907		

### TORPEDO SHIPS

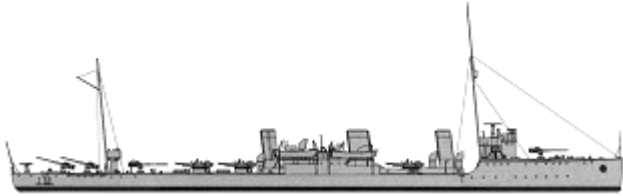
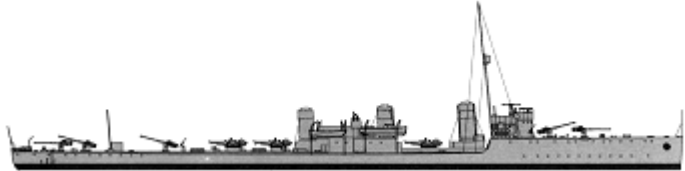
DD	Almirante Villar	1	1	Almirante Villar	1917		1620t, 98.0x9.3x3.9m, 4b,2t, 31500hp, 34kts, 142p; 4x1-102/60, 1x1-40/39, 3x3-450TT, 80m
	Almirante Guise	1	2	Almirante Guise	1917		2200t, 107.0x9.5x4.1m, 5b,2t, 32700hp, 35kts, 142p; 5x1-102/60, 1x1-76/30, 3x3-450TT, 80m

### SUBMARINES

SS	R1	4	1	R1	1926		576/755t, 56.8x5.3x4.6m, 2d/em, 800/1000hp, 14.5/9.5kts, 30p, 60m; 1x1-76/50, 4-533TT
			2	R2	1926		
			3	R3	1928		
			4	R4	1928		

### OTHER FIGHTING SHIPS

PGR	Iquitos	1	1	Iquitos	1875	No picture	50t, 23.4x3.7x1.2m, 7.5kts; 4x1-37/23, 2x1-20/60
	América	1	2	América	1904	No picture	240t, 40.5x5.9x1.4m, 2b,2vte, 350hp, 14kts, 26p; 2x1-65/50, 3x1-47/40, 2x1-20/60
	Napo	1	3	Napo	1920	No picture	98t, 30.9x5.5x0.9m, 1b,1vte, 250hp, 12kts, 22p; 4x1-47/40, 2x1-20/60
	Amazonas	2	4	Amazonas	1935	No picture	250t, 46.7x6.7x1.4m, 2d, 750hp, 15.5kts, 35p; 4x1-76/50, 2x1-47/40
5			Loreto	1935			

© Ivan Gogin, 2012-15

[home](#)[World navies yesterday](#)[1940](#)

## Philippines 01 January 1940

### COASTAL FORCES

PT	Luzon	1	1	Q111 Luzon	1939	No picture	40t, 19.8x4.7x1.5m, 3pe, 1800hp, 41kts, 6p; 3x1-12.7, 2-450TT, 1DCR
	Abra	1	2	Q112 Abra	1939		14t, 16.8x4.0x1.0m, 2pe, 2000hp, 55kts, 5p; 2x1-12.7, 2-450TT, 1DCR

© Ivan Gogin, 2011-15

[home](#)[World navies yesterday](#)[1940](#)

## POLAND 01 January 1940

### TORPEDO SHIPS

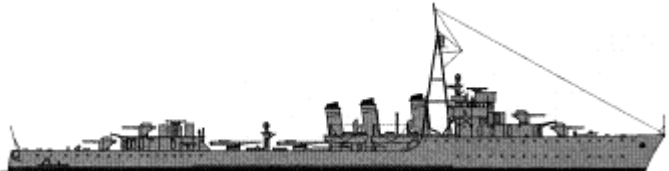
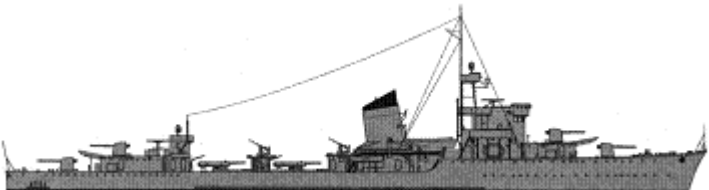
DD	Wicher	1	1	Burza	1932		1920t, 107.2x10.2x3.3m, 3b,2gt, 33000hp, 33kts, 155p; 4x1-130/40, 2x1-40/39, 2x2-13.2, 2x3-550TT, 60m, 2DCT, 2DCR
	Grom	2	3	Błyskawica Grom	1937 1937		2383t, 114.0x11.3x3.5m, 4b,2gt, 54000hp, 39kts, 200p; (3x2+1x1)-120/50, 2x2-40/60, 4x2-13.2, 2x3-533TT, 44m, 2DCR

### SUBMARINES

SS	Wilk	3	1	Ryś	1931		980/1248t, 78.5x5.9x4.2m, 2d/em, 1800/1200hp, 14.5/9.5kts, 54p, 80m; 1x1-100/40, 1x2-13.2, (4+1x2)-550TT, 38m
			2	Wilk	1931		
			3	Żbik	1932		
	Orzeł	2	4	Orzeł	1939		1473/1650t, 84.0x6.7x4.2m, 2d/em, 4740/1100hp, 19.4/9kts, 60p, 80m; 1x1-105/41, 1x2-40/60, 1x2-13.2, (8+2x2)-550TT
			5	Sęp	1939		

### BOARD GUARD



YP	Batory	1	1	Batory	1932	No picture	28t, 21.2x3.6x1.1m, 3pe, 1100/175hp, 24.3kts, 10p
----	--------	---	---	--------	------	------------	---

© Ivan Gogin, 2011-15

[home](#)[World navies yesterday](#)[1940](#)

## PORTUGAL 01 January 1940

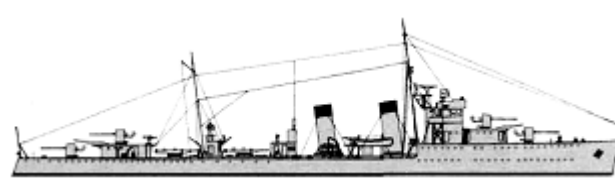
### TORPEDO SHIPS



	Guadiana	1	1	Tâmega	1923		660t, 73.2x7.2x2.3m, 3b,2t, 11000hp, 27kts, 80p; 1x1-100/41, 2x1-76/40, 2x2-450TT
DD	Vouga	5	2	Lima	1933		1563t, 98.5x9.5x3.4m, 3b,2gt, 33000hp, 36kts, 127p; 4x1-120/50, 3x1-40/39, 2x4-533TT, 20m 2DCR
			3	Vouga	1933		
			4	Dão	1935		
			5	Tejo	1935		
			6	Douro	1936		
TB	82F	2	1	Ave	1916		330t, 58.8x5.8x1.5m, 2b,2t, 5000hp, 28kts, 38p; 1x1-66/30, 1x1-57/40, 2x2-450TT
			2	Sado	1916		

### SUBMARINES

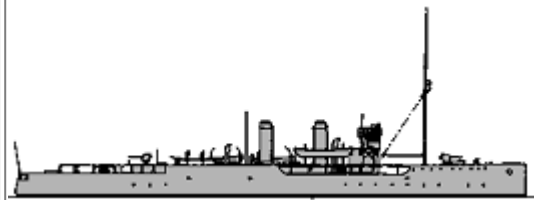

SS	Delfim	3	1	Delfim	1935		800/1092t, 69.2x6.5x3.9m, 2d/em, 2300/1000hp, 16.5/9.2kts, 38p; 1x1-102/40, 2x1-12.7, 6-533TT
			2	Espadarte	1935		
			3	Golfinho	1935		

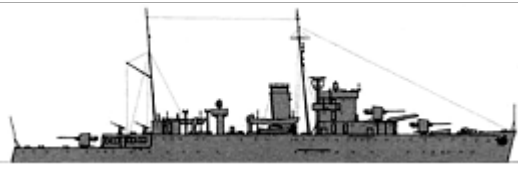
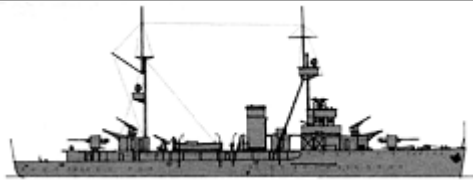
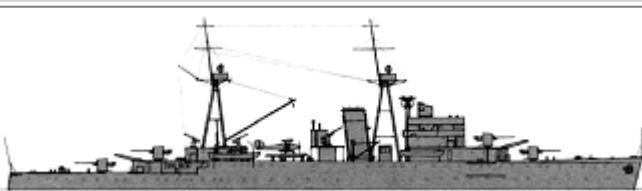
### ESCORTS

	República	1	1	República	1915		1350t, 81.7x10.2x3.4m, 2b,1vte, 2000hp, 16kts, 137p; 2x1-102/40, 2x1-76/40, 4x1-47/40
			2	Gonçalo Velho	1933		

SL	Gonçalo Velho	2	3	Gonçaves Zarco	1933		1414t, 81.7x10.8x3.4m, 2b,2gt, 2000hp, 16.5kts, 142p; 3x1-120/50, 4x1-40/39, 2DCR
			4	Pedro Nunes	1935		1220t, 71.4x10.0x2.8m, 2d, 2400hp, 16.5kts, 138p; 2x1-120/50, 2x1-76/50, 4x1-40/39, 2DCR
				5	João de Lisboa		
	Afonso de Albuquerque	2	6	Afonso de Albuquerque	1935		2480t, 103.2x13.5x3.8m, 2b,2gt, 8000hp, 21kts, 184p; 4x1-120/50, 2x1-76/50, 4x1-40/39, 2DCR, 40m
			7	Bartolomeu Dias	1935		
	PC	Lince	1	1	Lince	1911	No picture
Torres Garcia		1	2	Torres Garcia	1928	No picture	250t, 28.0xxm, 1b,1vte,
FPV	Faro	2	1	Faro	1928		300t, 39.8x6.7x3.2m, 1b,1vte, 650hp, 13kts, 52p; 2x1-47/40
			2	Lagos	1930		

## OTHER FIGHTING SHIPS

PG	Limpopo	1	1	Limpopo	1890	No picture	288t, 37.8x6.4x2.0m, 1b,1vc, 520hp, 11.3kts, 54p; 3x1-57/40
	Beira	2	2	Ibo	1911		492t, 45.0x8.3x2.1m, 2b,2vte, 700hp, 13kts, 51p; 2x1-76/50(2), 2x1-47/40(2), 4x1-47/40(3)
			3	Mandovi	1917		
	Zaire	3	4	Zaire	1925		492t, 45.0x8.3x2.1m, 2b,2vte, 700hp, 13kts, 67p; 2x1-76/40, 2x1-47/40
			5	Damao	1927		
			6	Diu	1929		
PR	Rio Minho	1	1	Rio Minho	1904	No picture	38t, 24.6x4.0x0.6m, 1b,vte(sw), 64hp, 7.5kts, 8p; 1x1-37/20
	Macau	1	2	Macau	1910		133t, 36.5x6.0x0.7m, 1b,1vte, 250hp, 11.8kts, 24p; 2x1-57/40
	Téte	1	3	Téte	1920	No picture	130t, 23.4x6.1x0.7m, 1b,1vt2(sw), 70hp, 8kts, 20p; 2x1-47/40

## MINE WARFARE SHIPS

ML	Vulcano	1	1	Vulcano	1910		151t, 33.5x5.9x1.3m, 1b,2vte, 412hp, 12kts, 24p; 50m
----	---------	---	---	---------	------	--	--







[home](#)[World navies yesterday](#)[1940](#)

## Romania 01 January 1940

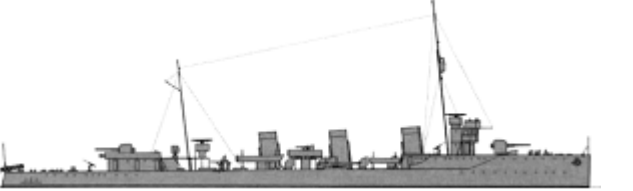
### TORPEDO SHIPS

DD	Mărăști	1	Mărăști	1917		1723t, 94.7x9.5x3.5m, 5b,2t, 45000hp, 34kts, 139p; 2x2-120/45, 2x1-37/83, 2x2-13.2, 2x2-450TT, 1DCT, 2DCR, 50m
		2	Mărășești	1918		
	Regele Ferdinand	3	Regele Ferdinand	1930		
		4	Regina Maria	1930		
TB	Viforul	1	Sborul	1914		320t, 58.2x5.7x1.5m, 2b,2t, 5000hp, 28kts, 41p; 1x1-66/30, 1x1-37/83, 1x1-20/65, 2x2-450TT, 4DCT, 2DCR
	Naluca	2	Naluca	1916		
		3	Smeul	1916		



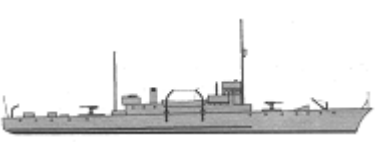

### SUBMARINES

SS	Delfinul	1	Delfinul	1936		650/900t, 68.6x5.9x3.7m, 2d/em, 800/800hp, 14/9kts, 40p, 80m; 1x1-102/35, 6-533TT
----	----------	---	----------	------	--	---

### ESCORTS

FS	Căpitan Dumitrescu	4	1	Căpitan Dumitrescu	1917		443t, 60.2x7.0x2.6m, 2d, 900hp, 14.5kts, 50p; 2x1-37/83, 2DCT, 20m(3)
			2	Locotenent-Comandor Stihii Eugen	1917		
			3	Locotenent Lepri Remus	1918		
			4	Sublocotenent Ghiculescu	1918		

## OTHER FIGHTING SHIPS

MONR	Ion C. Brătianu	1	Ion C. Brătianu	1907		750t, 62.0-63.5x10.5x1.8m, 2b,2vte, 1800hp, 13kts, 110p; 70belt, 70deck, 75turrets, 75CT; 3x1-120/50, 1x1-37/83, 1x2-13.2
		2	Lascar Catargiu	1907		
		3	Alexandru Lachovari	1908		
		4	Mihail Kogălniceanu	1907		
MONR	Ardeal	1	Ardeal	1905		650t, 60.3x9.5x1.6m, 2b,2vte, 1400hp, 13kts, 89p; 40belt, 25deck, 75turrets, 40CT; 2x1-120/50, 2x1-90/45
	Bucovina	1	Bucovina	1915		~700t, 62.2x10.3x1.3m, 2b,2vte, 1750hp, 13.5kts, 91p; 40belt, 25deck, 50turrets, 50CT; 1x2-120/40, 3x1-37/83, 2x1-20/65, 1x2-13.2
	Basarabia	1	Basarabia	1915		770t, 62.0x10.5x1.8m, 2b,2vte, 1600hp, 12.2kts, 133p; 40belt, 35deck, 50turrets, 40CT; 1x2-120/40, 3x1-120/10, 1x1-37/83, 2x1-20/65, 1x2-13.2
FBR	MR491	1	MR491	1916		255t, 54.7x7.1x1.2m, 2sd, 100hp, 5.5kts; 1x1-152/45(4-6), 2x1-120/45(1-3)
		2	MR492	1916		
		3	MR493	1916		
		4	MR494	1916		
		5	MR495	1916		
		6	MR496	1916		

## COASTAL FORCES

YPR	Căpităn Nicolae Lascăr Bogdan	4	1 - 4	V1-4	1906 - 1907		51t, 30.4x4.0x0.8m, 2b,2vce, 550hp, 18kts, 20p; 1x1-47/44
-----	-------------------------------	---	-------	------	-------------	---	---

## MINE WARFARE SHIPS

ML	Aurora	1	1	Aurora	1903	No picture	314t, 49.1x8.0x1.5m, 1b,1vte, 550hp, 11kts, 40p; 1x2-13.2, 40m
----	--------	---	---	--------	------	------------	--

[home](#)[World navies yesterday](#)[1940](#)

## SOUTH AFRICA 01 January 1940

### MINE WARFARE

AMS	-	1	1	Africana	1930		313t; 1x1-76/40
TL	-	7	1	Algoa Bay	1919		270t
			2	Babiana	1935		262t
			3	Bluff	1935		262t
			4	David Haigh	1918		276t
			5	Disa	1924		197t
			6	Mooivlei	1935		252t
			7	Nerine	1925		197t
WL	-	1	1	Swartberg	1923		220t

© Ivan Gogin, 2010-15

[home](#)[World navies yesterday](#)[1940](#)

## SOVIET UNION 01 January 1940

*IN SERVICE: 3 battleships, 2 heavy cruisers, 2 protected cruisers, 2 light cruisers, 6 destroyer leaders, 34 destroyers, 175 submarines, 18 corvettes, 2 patrol ships, 14 auxiliary patrol vessels, 12 gunboats, 4 auxiliary gunboats, 1 dispatch vessel, 20 river monitors, 6 river gunboats, 2 auxiliary river gunboats, 272 motor torpedo boats, 27 motor anti-submarine boats, 2 patrol motor launches, 3 auxiliary patrol motor launches, 77 armoured river motor gunboats, 2 minelayers, 9 auxiliary minelayers, 1 river minelayer, 2 auxiliary netlayers, 35 minesweepers, 44 auxiliary minesweepers, 4 auxiliary river minesweepers, 19 minesweeping boats, 6 Board Guard corvettes, 3 Board Guard ships, 2 auxiliary Board Guard ships, 122 Board Guard motor boats, 94 Board Guard launches*

### CAPITAL SHIPS

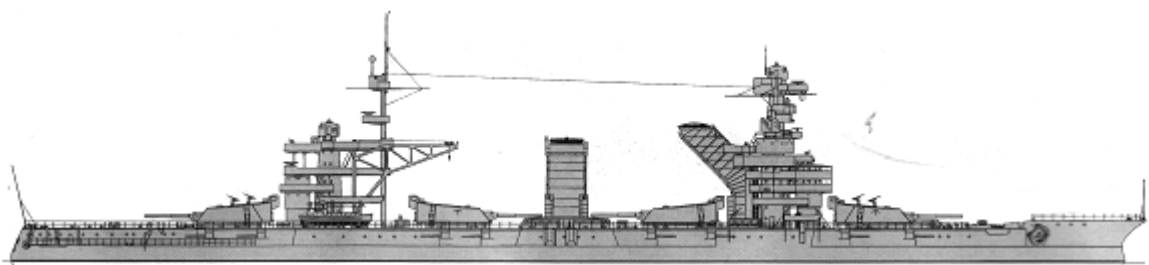
BB	Sevastopol	3	1	Oktyabrskaya Revolyutsiya	1914		26900(2)-26700(1,3)t, 184.9x26.9x8.4m, 12b(1,2)-22b(3),4t, 60600(1,2)-61100(3)hp, 22.5(1,2)-23.8(3)kts, 1140p; 225belt, 75deck, 305turrets, 250CT; 4x3-305/52, 16x1-120/50, 6x1-76/55(2), 6x1-76/30(1,3), 6x1-45/46(2), 12x1-12.7(2), 4-450TT(1,3), 1seaplane (KOR-1)(1), 2seaplanes(KOR-1)(2)
			2	Parizhskaya Kommuna	1914		
			3	Marat	1915		

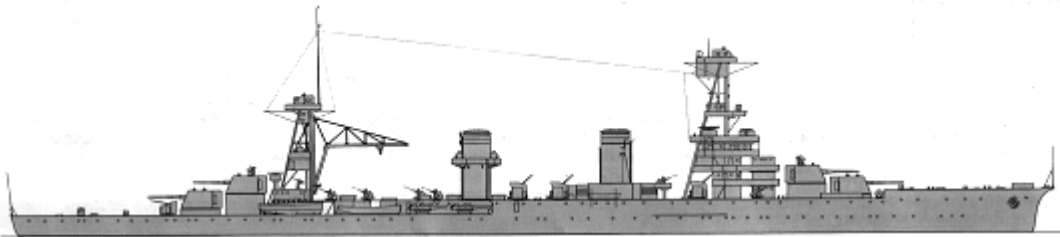

### CRUISERS

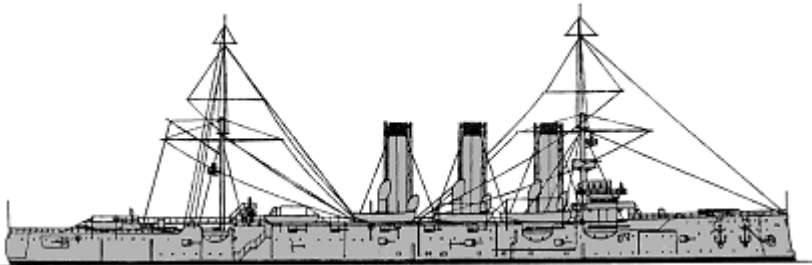
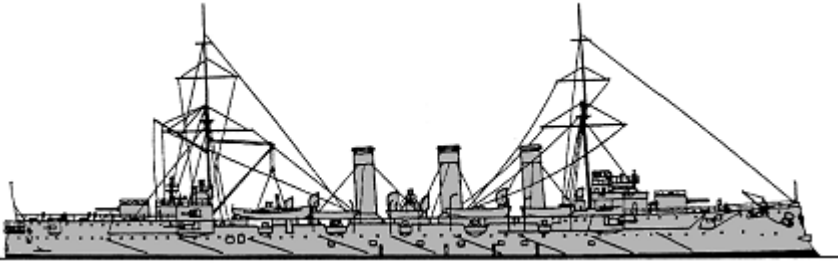
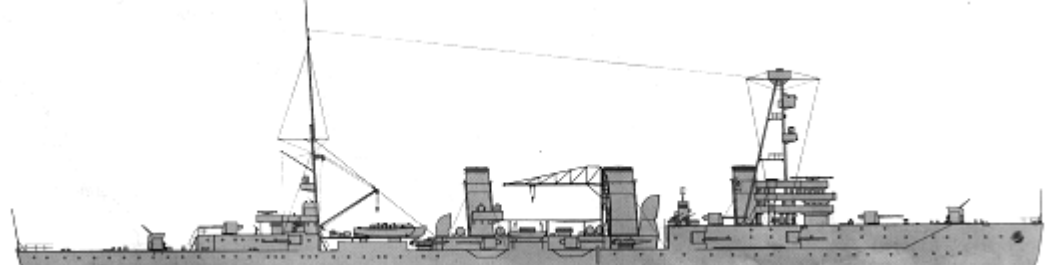
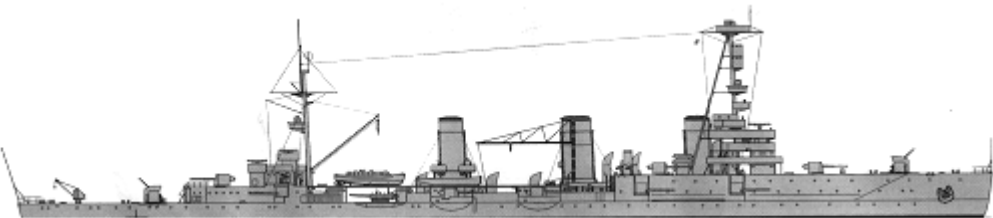
CA	Krasny Kavkaz	1	1	Krasny Kavkaz	1932		8888t, 169.5x15.7x6.6m, 10b,4t, 55000hp, 29kts, 850p; 75belt, 45deck, 25turrets, 75CT; 4x1-180/60, 4x2-100/47, 4x1-45/46, 4x3-450TT, 100m, 2seaplanes (KR-1)
	pr. 26	1	2	Kirov	1938		

CL	Pallada	1	1	Avrora (TS)	1903		6897t, 126.8x16.8x6.4m, 24b,3vte, 11610hp, 19.2kts, 570p; nickel steel: 38/63deck, 25shields, 152CT; 9x1-130/55, 2x1-76/30, 2x1-45/46, 126m
	Bogatyry	1	2	Komintern	1905		7790t, 134.0x16.6x6.3m, 12b,2vte, 5000hp, 12kts, 581p; 35/70deck, 127turrets, 80casemates, 140CT; 10x1-130/55, 4x1-76/30, 2-450TT, 290m
	Admiral Nakhimov	1	3	Chervona Ukraina	1927		8268t, 166.8x15.7x6.2m, 14b,4t, 55000hp, 29kts, 830p; 75belt, 40deck, 25shields, 75CT; 15x1-130/55, 3x2-100/47, 4x3-450TT, 90m, 1seaplane (MU-2)
	Svetlana	1	4	Krasny Krym	1928		8041t, 158.4x15.4x6.7m, 13b,4t, 46300hp, 29kts, 830p; 75belt, 40deck, 25shields, 75CT; 15x1-130/55, 3x2-100/47, 4x1-45/46, 7x1-12.7, 2x3-533TT, 90m

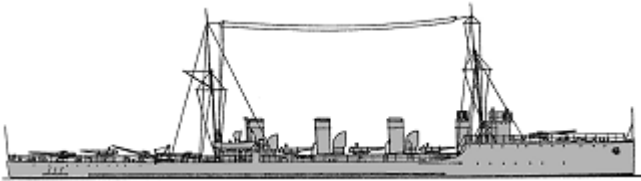
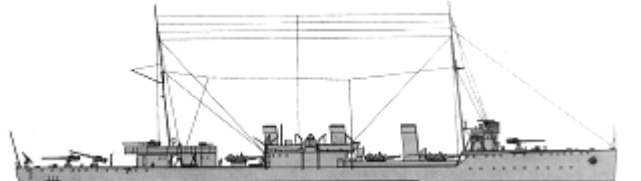

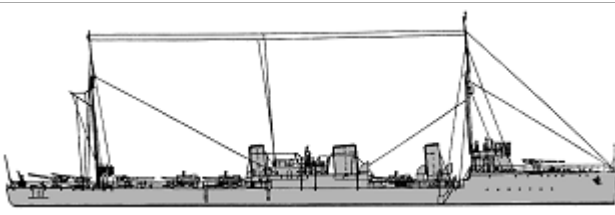
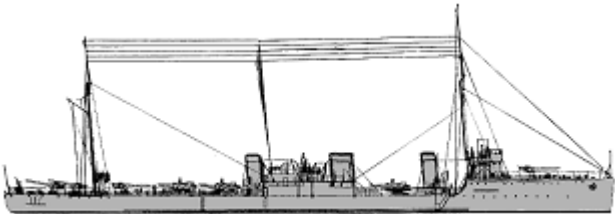
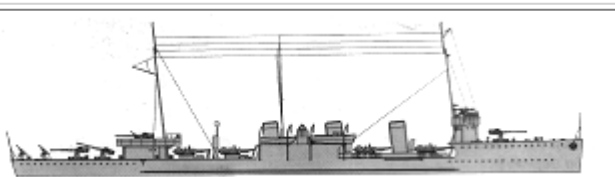
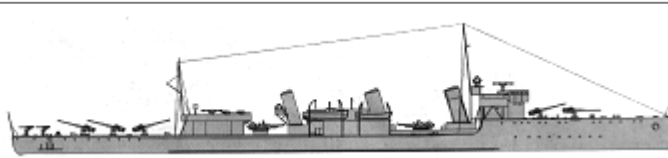
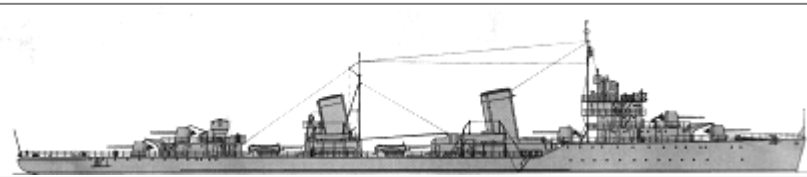
## TORPEDO SHIPS

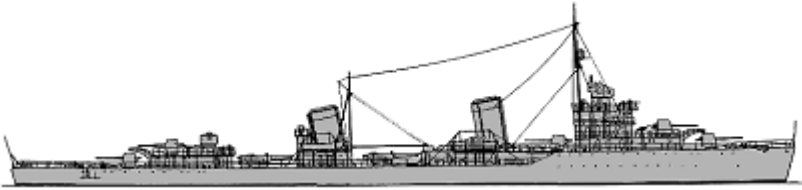
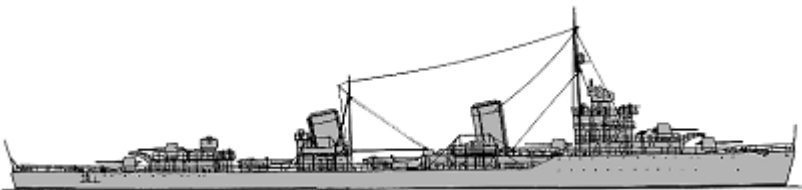
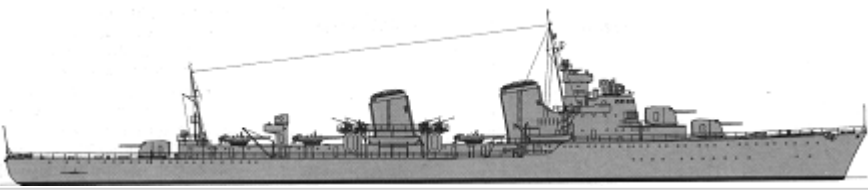

Novik	1	1	Yakov Sverdlov	1913		1595t, 102.4x9.5x3.5m, 6b,3t, 35100hp, 36kts, 113p; 4x1-102/60, 1x1-76/30, 3x3-450TT, 2DCR, 58m
Schastlivy	1	2	Frunze	1915		1450t, 98.0x9.3x3.4m, 5b,2t, 23000hp, 34kts, 112p; 4x1-102/60, 1x1-76/30, 3x3-450TT, 2DCR, 40m
Pobeditel	5	3	Volodarskiy	1915		1450t, 98.0x9.3x3.2m, 4b,2t, 30000hp, 35kts, 112p; 4x1-102/60, 1x1-76/30(3-6), 2x1-45/46(7), 4x1-12.7(5,6), 3x3-450TT, 2DCR, 58m
		4	Uritskiy	1915		
		5	Engels	1916		

DD									
							6	Artyom	1916
							7	Stalin	1916
	Kapitan Izlymetyev	4	8	Lenin	1916		1450(8,9)-2020(10,11)t, 98.0x9.3x3.9(8,9)-4.0(10,11)m, 4b,2t, 31500hp, 34kts, 150p; 4x1-102/60, 1x1-76/30, 2x1-45/46(9), 3x3-450TT, 2DCT(10,11), 2DCR, 58(8,9)-50(10,11)m		
			9	Voykov	1916				
			10	Valerian Kuybyshev	1927				
			11	Karl Libknekht	1928				
	Fidonisi	4	12	Dzerzhinskiy	1917		1760t, 92.5x9.1x3.8m, 5b,2t, 29000hp, 33kts, 136p; 4x1-102/60, 2x1-76/30, 4x3-450TT, 2DCR, 60m		
			13	Nezamozhnik	1923				
			14	Zheleznyakov	1925				
			15	Shaumyan	1925				
	Izyaslav	2	16	Karl Marx	1917		1570t, 107.0x9.5x4.1m, 5b,2t, 32700hp, 35kts, 150p; 5x1-102/60, 1x1-76/30(17), 4x1-45/46(16), 2x3-450TT(16), 3x3-450TT(17), 2DCR(16), 60m(16), 80m(17)		
			17	Kalinin	1927				
	pr. 1	3	18	Leningrad	1936		2582t, 127.5x11.7x4.1m, 3b,3gt, 66000hp, 36kts, 250p; 5x1-130/51, 2x1-76/55, 2x1-45/46, 4x1-12.7, 2x4-533TT, 2DCR, 76m		
			19	Moskva	1938				
			20	Kharkov	1938				
	pr. 7	17	21	Gremyashchiy	1938		2039t, 112.8x10.2x3.3m, 3b,2gt, 48000hp, 37kts, 246p; 4x1-130/51, 2x1-76/55, 2x1-45/46, 2x1-12.7, 2x3-533TT, 2DCR, 56m		
			22	Bodry	1938				
			23	Smetlivy	1938				
			24	Stremitelny	1938				
			25	Grozny	1938				
			26	Gnevny	1938				
			27	Gordy	1938				
			28	Gromkiy	1938				
			29	Bystry	1939				
			30	Boykiy	1939				
			31	Ryany	1939				
			32	Sokrushitelny	1939				
			33	Grozyashchiy	1939				
			34	Bezuprechny	1939				
			35	Besposhchadny	1939				
			36	Bditelny	1939				
			37	Steregushchiy	1939				

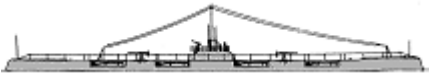
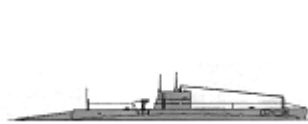
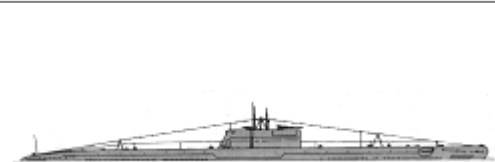
pr. 38	1	38	Minsk	1939		2597t, 127.5x11.7x4.1m, 3b,3gt, 66000hp, 36kts, 250p; 5x1-130/51, 3x1-76/55, 2x1-45/46, 6x1-12.7, 2x4-533TT, 2DCR, 76m
pr. 38-bis	1	39	Sergo Ordzhonikidze	1939		2597t, 127.5x11.7x4.1m, 3b,3gt, 66000hp, 36kts, 250p; 5x1-130/51, 3x1-76/55, 2x1-45/46, 6x1-12.7, 2x4-533TT, 2DCR, 76m
pr. 20-I	1	40	Tashkent	1939		3200t, 139.8x13.7x3.7m, 2b,2gt, 110000hp, 39kts, 250p; 3x1-130/51, 6x1-45/46, 6x1-12.7, 3x3-533TT, 2DCR, 80m

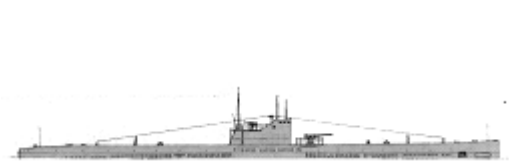
## SUBMARINES

Bars	1	1	B-2	1916		670/810t, 68.0x4.5x4.3m, 2d/em, 500/900hp, 12/8kts, 44p, 50m; 2x1-75/50, 1x1-37/30, 12-450TT
AG	5	2	A-1	1920		355/434t, 46.0x4.9x3.8m, 2d/em, 960/480hp, 13/8kts, 24p, 50m; 1x1-45/46, 4-450TT
		3	A-2	1921		
		4	A-3	1922		
		5	A-4	1923		
		6	A-5	1918		
ser. I	6	7	D-1	1930		933/1354(7-9) -945/1355(10) -989/1385(11,12), 76.0(7-9) -76.6(10-12)x6.4x3.8(7-9,11,12) -4.3(10)m, 2d/em, 2200/1050hp, 14/9(7-9) -12.5/8.2(10) -11.3/8.7(11,12)kts, 47p, 75m; 1x1-102/45(8-12), 1x1-100/51(7), 1x1-45/46(7), 1x1-37/30(8-12), 8-533TT
		8	D-2	1931		
		9	D-3	1931		
		10	D-4	1930		
		11	D-5	1931		
		12	D-6	1931		
L50	1	13	L-55	1918		954/1139t, 71.6x7.2x4.1m, 2d/em, 2200/1600hp, 13.5/8.2kts, 49p, 50m; 2x1-75/50, 6-533TT
Ser. II	6	14	L-1	1933		1040/1335(14,15)-1051/1327(16)-1038/1330(17-19)t, 78.0(14-16,18,19) -78.5(17)x7.3(14,15) -7.2(16,18,19) -7.0(17)x4.0(14-16) -4.2(17,19) -4.3(18)m, 2d/em, 2200/1300hp, 14.8/8.5(14-16)-12.5/8.2(17) -13.8/8.3(18) -11.3/8(19)kts, 55p, 75m; 1x1-102/45(15-19), 1x1-100/51(14), 1x1-45/46(14-16,18), 6-533TT, 17m(14,15), 20m(16-19)
		15	L-2	1933		
		16	L-3	1933		
		17	L-4	1933		
		18	L-5	1933		
		19	L-6	1935		
		20	Shch-301	1933		

Ser. III	4	21	Shch-302	1933		578/706t, 57.0x6.2x3.9m, 2d/em, 1000(20,21)-1370(22,23)/800hp, 11.6(20,21)-12.5(22,23)/8.5kts, 41p, 75m; 1x1-45/46, 6-533TT
		22	Shch-303	1933		
		23	Shch-304	1934		
Ser. V	11	24	Shch-101	1933		585/700t, 58.5x6.2x3.9m, 2d/em, 1370/800hp, 11.9/8.5kts, 40p, 75m; 2x1-45/46, 6-533TT
		25	Shch-102	1933		
		26	Shch-104	1933		
		27	Shch-105	1933		
		28	Shch-106	1933		
		29	Shch-107	1933		
		30	Shch-108	1933		
		31	Shch-109	1934		
		32	Shch-110	1934		
		33	Shch-111	1934		
Ser. V-bis	13	34	Shch-112	1934		601/772(35-42) -607/750(43-45)-586/702(46,47)t, 58.0(35-42)-58.8(43-47)x 6.2x3.9(35-42) -4.3(43-45) -4.2(46,47)m, 2d/em, 1370/800hp, 12/8(35-42) -11.9/7.5(43-45) -12.9/7(46,47)kts, 40p, 75m; 1x1-45/46(35-42), 2x1-45/46(43-47), 1x1-12.7(35-42), 6-533TT
		35	Shch-113	1934		
		36	Shch-114	1934		
		37	Shch-115	1934		
		38	Shch-116	1935		
		39	Shch-117	1934		
		40	Shch-118	1934		
		41	Shch-119	1935		
42	Shch-120	1935				
43	Shch-201	1935				
44	Shch-	1935				





		202	
	45	Shch-203	1935
	46	Shch-305	1934
	47	Shch-308	1935
Ser. VI	30	48	M-1 1934
		49	M-2 1934
		50	M-3 1934
		51	M-4 1934
		52	M-5 1934
		53	M-6 1934
		54	M-7 1934
		55	M-8 1934
		56	M-9 1934
		57	M-10 1934
		58	M-11 1934
		59	M-12 1934
		60	M-13 1934
		61	M-14 1934
		62	M-15 1934
		63	M-16 1934
		64	M-17 1934
		65	M-18 1934
		66	M-19 1934
		67	M-20 1934
68	M-21 1934		
69	M-22 1934		
70	M-23 1934		
71	M-24 1934		
72	M-25 1934		
73	M-26 1934		
74	M-27 1934		
75	M-28 1935		
76	M-51 1934		
77	M-52 1934		
	78	Shch-121	1935
	79	Shch-122	1935
	80	Shch-	1935



161/201t, 36.9x3.1x2.6m, 1d/em, 685/240hp, 11.1/6.4kts, 19p, 50m; 1x1-45/46, 2-533TT

SS	Ser. V- bis-2	14		123			<p>618/721(78-82) -610/706(83-86) - 589/708(87-91), 58.8(78-86) -57.8(87-91)x4.1(78-82) -4.3(83-86) -4.0(87-91)m, 2d/em, 1370/800hp, 11.9/6.7(78-82) -12.9/7.5(83-86) -12.3/8(87-91)kts, 40p, 75m; 2x1-45/46(78-86), 1x1-45/46(87-91), 2x1-12.7(87-91), 6-533TT</p>
			81	Shch-124	1935		
			82	Shch-125	1936		
			83	Shch-204	1935		
			84	Shch-205	1936		
			85	Shch-206	1936		
			86	Shch-207	1936		
			87	Shch-306	1935		
			88	Shch-307	1935		
			89	Shch-309	1935		
			90	Shch-310	1936		
			91	Shch-311	1936		
	Ser. VI- bis	20	92	M-47	1935		<p>161/202t, 37.8x3.1x2.6m, 1d/em, 685/240hp, 13.2/7.2kts, 17p, 50m; 1x1-45/46, 2-533TT</p>
			93	M-54	1936		
			94	M-55	1936		
			95	M-48	1936		
			96	M-71	1935		
			97	M-72	1935		
			98	M-73	1935		
			99	M-74	1935		
			100	M-75	1935		
			101	M-76	1935		
			102	M-77	1936		
			103	M-78	1936		
104	M-79	1936					
105	M-80	1936					
106	M-81	1936					
107	M-43	1935					
108	M-83	1935					
109	M-44	1935					
110	M-45	1935					
111	M-46	1935					
			112	P-1	1936		

Ser. IV	3	113	P-2	1936		955/1690t, 87.7x8.0x2.9m, 2d/em, 5400/1100hp, 18.8/6.5kts, 56p, 50m; 2x1-100/51, 1x1-45/46, 6-533TT
		114	P-3	1936		
Ser. IX	3	115	S-1	1936		840/1070t, 77.8x6.4x4.4m, 2d/em, 4000/1100hp, 19.5/9kts, 46p, 75m; 1x1-100/51, 1x1-45/46, 6-533TT
		116	S-2	1936		
		117	S-3	1938		
Ser. X	27	118	Shch-126	1936		590/708t, 58.8x6.2x4.0m, 2d/em, 1600/800hp, 14/8.5kts, 40p, 75m; 2x1-45/46, 6-533TT
		119	Shch-127	1936		
		120	Shch-128	1936		
		121	Shch-129	1936		
		122	Shch-130	1936		
		123	Shch-131	1936		
		124	Shch-132	1936		
		125	Shch-133	1936		
		126	Shch-134	1936		
		127	Shch-208	1937		
		128	Shch-209	1937		
		129	Shch-210	1937		
		130	Shch-211	1938		
		131	Shch-212	1938		
		132	Shch-213	1938		
		133	Shch-214	1939		
		134	Shch-215	1939		
		135	Shch-401	1936		
		136	Shch-421	1937		
		137	Shch-402	1936		

138	Shch-422	1937
139	Shch-403	1936
140	Shch-423	1937
141	Shch-404	1936
142	Shch-317	1936
143	Shch-318	1936
144	Shch-319	1936
141	Shch-320	1936
142	Shch-322	1936
143	Shch-323	1936
144	Shch-324	1936

Ser.  
XI

6

145	L-7	1936
146	L-8	1936
147	L-9	1936
148	L-10	1937
149	L-11	1938
150	L-12	1938



1040/1335t, 79.9x7.0x4.0m, 2d/em, 2200/1300hp, 14.5/8.5kts, 55p, 75m; 1x1-100/51, 1x1-45/46, 6-533TT, 20m



Ser.  
XII

13



151	M-49	1939
152	M-58	1939
153	M-171	1937
154	M-172	1937
155	M-173	1938
156	M-90	1938
157	M-174	1938
158	M-175	1938
159	M-176	1938
160	M-94	1939
161	M-95	1939



206/256t, 44.5x3.3x2.6m, 1d/em, 800/400hp, 14/8.2kts, 20p, 50m; 1x1-45/46, 2-533TT

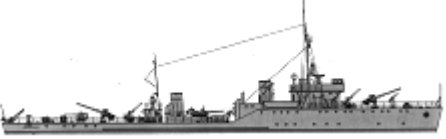
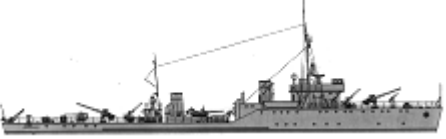
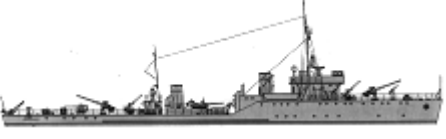

		162	M-96	1939		
		163	M-97	1939		
Ser. XIII	7	164	L-13	1938		1120/1425t, 85.3x7.0x4.1m, 2d/em, 2200/1300hp, 15/9kts, 56p, 80m; 1x1-100/51, 1x1-45/46, 8-533TT, 18m
		165	L-14	1938		
		166	L-15	1938		
		167	L-16	1938		
		168	L-17	1939		
		169	L-18	1939		
		170	L-19	1939		
Ser. IX-bis	3	171	S-4	1939		844/1077t, 77.7x6.4x4.0m, 2d/em, 4000/1100hp, 19.4/9.5kts, 46p, 80m; 1x1-100/51, 1x1-45/46, 6-533TT
		172	S-5	1939		
		173	S-6	1939		
Ser. XIV	2	174	K-1	1939		1487/2110t, 97.8x7.4x4.0m, 2d/em, 8400/2400hp, 22.5/10.3kts, 66p, 80m; 2x1-100/51, 2x1-45/46, 10-533TT, 20m
		175	K-2	1939		





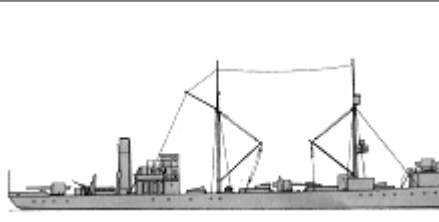
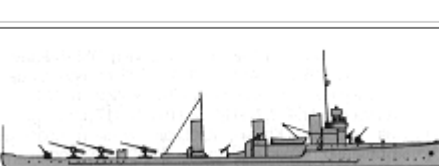
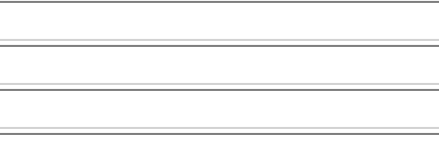
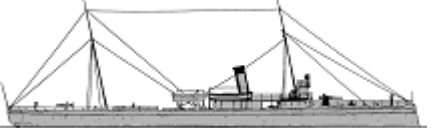

## ESCORTS

FS	pr. 2	8	1	Uragan	1930		534t, 71.5x7.4x2.5m, 2b,2gt, 6300hp, 26kts, 85p; 2x1-102/60, 4x1-45/46, 2x1-12.7, 1x3-450TT, 32m
			2	Tayfun	1931		
			3	Smerch	1932		
			4	Tsiklon	1932		
			5	Groza	1932		
			6	Vikhr	1932		
			7	Shtorm	1932		
			8	Shkval	1933		
	pr. 4	4	9	Metel	1934		531t, 71.5x7.4x2.3m, 2b,2gt, 6300hp, 25kts, 101p; 2x1-102/60, 3x1-45/46, 2x1-12.7, 1x3-450TT, 32m
			10	Vyuga	1934		
			11	Grom	1935		
			12	Burun	1935		
	pr. 39	6	13	Molniya	1936		568t, 71.5x7.4x2.4m, 2b,2gt, 6300hp, 24kts, 101p; 2x1-102/60(13-16), 2x1-100/56(17,18), 4x1-45/46, 2x1-12.7, 1x3-450TT, 2DCR, 24m
			14	Zarnitsa	1936		
			15	Purga	1936		
			16	Burya	1936		
			17	Sneg	1938		
			18	Tucha	1938		
PC	Dozorny	1	1	Dozorny	1905		100t, 30.8x5.0x1.7m, 2b,1vte, 660hp, 16kts, 31p; 2x1-45/46
			2	Razvedchik	1905		
			1	DK-5	1932		1450t, 51.2x9.0x4.5m, 1b,1vte, 650hp, 11kts; 2x1-45/46, 2DCR
			2	DK-10	1930		1150t, 50.8x9.0x4.5m, 1b,1vte, 675hp, 10kts; 2x1-45/46, 2DCR
			3	DK-30	1931		1255t, 54.8x9.0x4.6m, 1b,1vte, 675hp, 10kts; 2x1-45/46, 2DCR

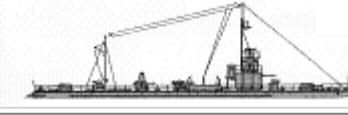
APC -	14	4	DK-38	1932	1255t, 54.8x9.0x4.6m, 1b,1vte, 675hp, 10kts; 2x1-45/46, 2DCR
		5	DK-60	1932	1107t, 53.4x9.0x4.5m; 1b,1vte, 650hp, 10.5kts; 2x1-45/46, 2DCR
		6	Dezhnyov	1938	7330t, 104.0x15.0x6.3m, 2500hp, 10.5kts; 4x1-76/55, 4x1-45/46, 6x1-12.7
		7	Veter	1929	5560t, 104.0x14.6x5.8m, 2200hp, 10.5kts; 4x1-76/55, 4x1-45/46, 2x1-12.7
		8	Briz	1931	800t
		9	DK-56	1931	800t
		10	DK-55	1931	800t
		11	DK-54	1931	800t
		12	DK-52	1931	800t
		13	Shtil	1931	800t
		14	LK-1	1905	140t







## OTHER FIGHTING SHIPS

PG	Khrabry	1	1	Krasnoye Znamya	1897		2100t, 72.3x12.7x3.4m, 8b,2vte, 2100hp, 14kts, 188p; Harvey steel: 127belt, 38deck, 38shields, 25CT; 5x1-130/50, 6x1-45/46, 2x1-12.7, 50m	
		Kars	2	2	Lenin	1910		635t, 61.6x8.5x2.6m, 2d, 2200hp, 15kts, 128p; 3x1-100/56, 2x1-45/46, 2x1-12.7, 30m
	3		3	Krasny Azerbaydzhan	1910			
	Elpidifor	4	4	4	Krasnaya Abkhaziya	1920		1300t, 74.7x10.4x1.8m, 2b,2vte, 750hp, 8.5kts, 169p; 3x1-130/55, 2x1-76/30, 180m, MS; 2000troops or 6 light tanks
			5	5	Krasny Adzharistan	1921		
			6	6	Krasny Krym	1924		
			7	7	Krasnaya Gruzija	1923		
	Ukrayna	3	10	10	Bakinskiy Rabochiy	1905		880t, 73.2x7.2x3.4m, 4b,2vte, 7000hp, 26kts, 88p; 3x1-102/60, 1x1-76/30
			11	11	Markin	1905		
			12	12	Altfater	1905		
APG -	4	1	1	Kronshtadt	1913		425t; 2x1-130/50	
		2	2	Krasnaya Gorka	1913			
		3	3	Oranienbaum	1913			
		4	4	Sestroretsk	1913			
DV	Abrek	1	1	Abrek	1897		675t, 65.5x7.8x3.4m, 4b,2vte, 4500hp, 21.2kts, 88p; 4x1-75/50, 1x1-37/23	
		1	1	Dzerzhinskiy	1910			

RMON	Tayfun	7	2	Lenin	1910		1000t, 70.9x12.8x1.4m, 4d, 1870(1,4,7) -1000(2,5) -2970(3,6)hp, 11.3(1,4,7) -10(2,5) -16.5(3,6)kts, 117p; 76belt, 19deck, 76turrets, 51CT; 4x1-152/50(6), 4x1-130/55(1,3,4), 4x2-120/50(2,5,7), 2x1-76/30(2,3,5,6), 2x1-45/46(1,7), 2x1-37/73(4), 4x1-12.7(4)
			3	Dalnevostochny Komsomolets	1910		
			4	Kirov	1910		
			5	Krasny Vostok	1910		
			6	Sverdlov	1910		
			7	Sun-Yat-Sen	1910		
			pr. SB-12	1	8		
pr. SB-30	1	9	Aktivny	1935		314t, 50.7x8.2x1.1m, 2d, 480hp, 8.5kts, 68p; 30belt, 16deck, 30turret, 30CT; 1x2-102/45, 2x2-45/46	
pr. SB-37	6	10	Zheleznyakov	1936		263t, 51.2x8.2x0.9m, 2d, 280hp, 8.3kts, 78p; 16belt, 4deck, 30turrets, 30CT; 1x2-102/45, 2x1-45/46	
		11	Levachov	1936			
		12	Zhemchuzhin	1936			
		13	Martynov	1936			
		14	Flyagin	1936			
		15	Rostovtsev	1937			
Zhitomir	4	16	Bobruysk	1920		130t, 34.5x5.1x0.7m, 2pe, 140(16-18)-200(19)hp, 9kts, 44p; 6belt, 10turrets, 10CT; (1x2+1x1)-75/36	
		17	Vinnitsa				
		18	Vitebsk				
		19	Zhitomir				
Smolensk	1	20	Smolensk	1926		90t, 36.6x6.2x0.7m, 2d, 120hp, 9kts, 40p; 6belt, 5deck, 12turret; 1x2-122/12, 1x2-45/46	
PGR	Buryat	2	1	Buryat	1907		288t, 54.5x8.2x0.9m, 2b,2vte, 480hp, 11.5kts, 40p; 12belt, 5deck, 8CT; 2x1-76/40, 2x1-45/46
			2	Mongol	1907		
	Vogul	3	3	Krasnaya Zvezda	1909		349t, 54.5x8.2x1.2m, 2b,2vte, 480hp, 10.5kts, 63p; 13belt, 9deck, 13CT; 2x1-102/60(3,4), 1x1-100/56(5), 1x1-76/30
			4	Proletariy	1909		
			5	Krasnoye Znamya	1909		
Trudovoy	1	6	Trudovoy	1933		35t, 18.1x4.6x0.3m, 2pe, 120hp, 6kts, 17p; 6belt, 6deck, 10turret, 6CT; 1x2-76/40, 1x1-76/30	
APR	-	2	1	Verny	1898		350t; 2x1-102/60, 1x1-76/30
			2	Peredovoy	1891		328t; 2x1-102/60, 1x1-76/30

## COASTAL FORCES

No1	5	1 - 5	No211-217		1906		35t, 27.4x3.7x1.5m, 2pe, 600hp, 20kts, 11p;
-----	---	-------	-----------	--	------	---	---

									1x1-47/43, 1x1-450TT
	ANT-3	1	6	Pervenets		1927		9t, 17.3x3.3x0.9m, 2pe, 1200hp, 54kts, 3p; 1- 450TT, 2m	
	Sh-4	40	7 - 46	No11, 21, No24 Proletariy Ukrainy, No32, 34, 42, 51, No55 Revolyutsionny Metallist, No55, 61, 62, 65, 71, 74, 81, 82, 84, 91, 94, 101, 102, 104, 111, 112, 114, 121, 122, 124, No131 Pioner, No134, 141, 144, 151, No154 Osoaviakhimovets, No161, No164 Sibiryak, No171, 174, No181 Partizan, No184		1928 - 1932		10t, 16.8x3.3x1.0m, 2pe, 1200hp, 45kts, 5p; 2- 450TT	
	S	2	47, 48	No54, 64		1931		28t, 23.5x3.8x1.9m, 3pe, 2250hp, 27kts, 6p; 3- 450TT	
PT	ANT-5	1	49	No1		1933		15t, 19.1x3.4x1.2m, 2pe, 2000hp, 58kts, 6p; 2- 533TT, 4m	
	G-5	221	50 - 270	No11, 11, 11, 12, 12, 12, 12, 13, 13, 14, 14, 14, 15, 16, 17, 21, 21, 21, 22, 22, 22, 22, 22, 23, 23, 23, 24, 24, 24, 25, 26, 27, 31, 31, 31, 32, 32, 32, 32, 33, 33, 34, 34, 35, 36, 37, 41, 41, 42, 42, 42, 42, 43, 43, 43, 44, 44, 45, 46, 47, 51, 51, 52, 52, 52, 52, 52, 53, 53, 54, 54, 55, 55, 55, 56, 57, 61, 61, 61, 62, 62, 62, 62, 62, 63, 63, 63, 64, 65, 66, 67, 71, 71, 71, 72, 72, 72, 73, 73, 73, 74, 74, 75, 76, 77, 81, 81, 81, 82, 82, 82, 83, 83, 85, 85, 86, 87, 91, 91, 91, 92, 92, 92, 93, 93, 94, 95, 95, 96, 97, 101, 101, 101, 102, 102, 102, 103, 104, 103, 104, 105, 106, 107, 111, 111, 111, 112, 112, 112, 112, 113, 113, 114, 114, 115, 116, 117, 121, 121, 121, 122, 122, 122, 122, 123, 123, 123, 124, 125, 126, 127, 131, 131, 132, 132, 133, 133, 137, 141, 141, 142, 142, 143, 143, 147, 151, 151, 152, 152, 153, 153, 154, 157, 161, 161, 161, 162, 162, 163, 163, 164, 167, 171, 171, 171, 172, 172, 173, 174, 177, 181, 181, 181, 181, 182, 182, 183, 183, 184, 185, 187		1933 - 1939		15-16t, 19.1 x3.3-3.4x 1.0- 1.2m, 2pe, 1700-2000hp, 45-52kts, 6p; (0-1)x1-12.7, 2-533TT	
	G-6	1	271	G-6		1939		86t, 36.5x6.6x1.9m, 8pe(2), 7760hp, 50kts, 30p; 1x1- 45/46, 1x1- 12.7, 3-533TT	
	L-5	1	272	TKL-1		1939		11t, 24.0x5.4x0m, 2pe, 2000hp, 70kts, 5p; 2x1- 12.7, 2-450TT	
PS	MO-4	27	1 - 27	No11-17, 111-113, 121-123, 131-133, 141, 142, MO-11-18, M-11		1937 - 1939		57t, 26.9x4.0x1.5m, 3pe, 2550hp, 25.5kts, 21p; 2x1-45/46, 2x1-12.7, 2DCR	
	No1	1	1	No211		1906		35t, 27.4x3.7x1.5m, 2pe, 600hp, 20kts, 11p;	









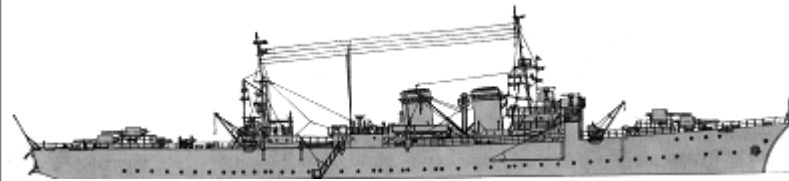
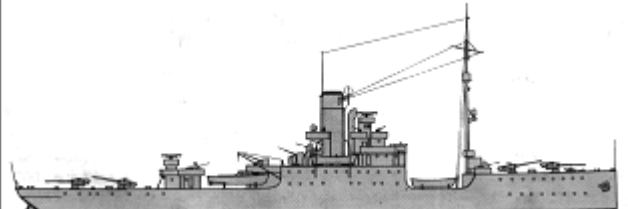

YP									2x1-45/46, 2x1-12.7, 2DCR
	Greenport-4	1	2	No1		1917		24t, 22.0x3.4x0.6m, 3pe, 1080hp, 30kts, 8p; 1x1-47/43, 1x1-37/23	
AYP	-	3	1	No5		1938		233t	
			2	PS-1		1937		110t	
			3	PS-1		1936		125t	
PGRA	Kopyo	2	1, 2	No93, 94		1910		25t, 22.2x3.1x0.5m, 2pe, 200hp, 14.5kts, 12p; 8belt, 8deck, 8CT: 1x1-76/16	
	K	4	3 - 6	No71, 73-75		1917		25t, 20.4x3.2x0.6m, 2pe, 150hp, 12.5kts, 12p; 5belt, 4deck, 6shields, 6CT; 2x1-76/16	
	N	4	7 - 10	No81-84		1916 - 1917		18t, 15.2x3.1x0.7m, 2pe, 100hp, 11.5kts, 8p; 7belt, 5deck, 7turret, 7CT; 1x1-76/16	
	D	4	11 - 14	No132-135		1916 - 1917		7t, 9.2x2.4x0.7m, 1pe, 80hp, 10.5kts, 7p; 5belt, 6turret, 6CT; 1x1-12.7	
	Partizan	2	15, 16	No91, 92		1932	No picture	56t, 32.0x3.4x0.9m, 2pe, 100hp, 10kts, 13p; 5belt, 5CT; 1x1-76/30	
	pr. 1124	28	17 - 44	No11-15, 21-25, 41-46, 51-56, 61-66		1936 - 1938		41t, 25.3x3.6x0.8m, 2pe, 1500hp, 21kts, 17p; 7belt, 4deck, 45turrets, 8CT; 2x1-	

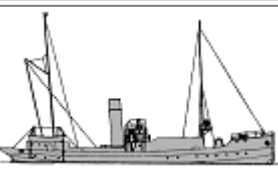
									76/17, 1x2-12.7	
pr. 1125	24	45 - 68	No16-19, 26-29, 31-38, 111-114, 121-124					1938 - 1939		30t, 22.7x3.5x0.6m, 1pe, 750hp, 19.7kts, 13p; 7belt, 4deck, 45turret, 7CT; 1x1-76/17, 2x2-12.7
No41	3	69 - 71	No41-43					1930s	No picture	10t, 8.6x2.4x0.5m, 1d, 35hp, 6kts; 2x1-12.7
No44	2	72, 73	No44, 45					1930s	No picture	12t, 11.2x3.0x0.6m, 1d, 40hp, 6kts; 2x1-12.7
No51	3	74 - 76	No51-53					1930s	No picture	12t, 11.2x3.0x0.6m, 1d, 40hp, 6kts; 2x1-12.7
No54	1	77	No54					1930s	No picture	12t, 11.2x3.0x0.6m, 1d, 40hp, 6kts; 2x1-12.7

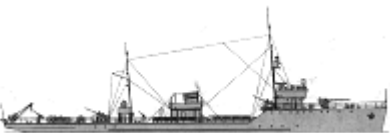
## MINE WARFARE SHIPS

ML	Bug	1	1	Gidrograf	1893		1490t, 62.2x10.4x4.6m, 4b,2vte, 13kts, 226p; 1x1-76/30, 350m
	Marti	1	2	Marti	1896		6189t, 122.3x15.4x7.0m, 4b,2vte, 11426hp, 18kts, 390p; 4x1-130/55, 7x1-76/55, 3x1-45/46, 390m
			1	Mina	1913		180t; 80m
			2	S. Ordzhonikidze	1923		5400t, 97.0x13.7x5.5m, 2b,1vte, 1550hp, 11kts; 4x1-130/55, 3x1-76/30, 4x1-37/73, 530m
			3	Astrakhan	1913		3725t, 91.1x12.3x5.2m, 2b,1vte, 1150hp, 9.8kts; 2x1-102/60, 2x1-76/30, 1x1-45/46,

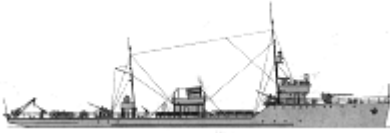





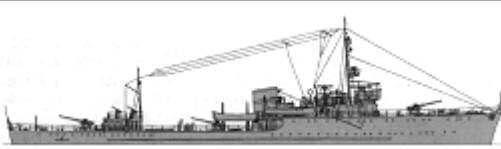
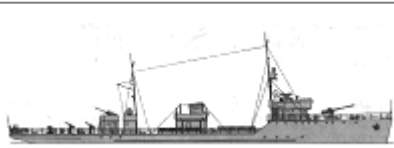

AML	-	9	4	Ayan	1935		820m	
			5	Voroshilovsk	1907		1975t, 74.0x10.4x3.3m, 2d, 750hp, 9kts; 1x1-76/30, 2x1-45/46, 200m	
			6	Gizhiga	1937		2300t, 63.5x10.0x4.6m, 2b,1vte, 750hp, 10.5kts; 4x1-76/30, 268m	
			7	Tomsk	1913		1600t, 74.1x10.4x3.3m, 2d, 750hp, 9kts; 1x1-76/30, 2x1-45/46, 138m	
			8	Pushkin	1929		4466t, 92.0x12.3x5.2m, 2b,1vte, 1200hp, 9kts; 9x1-45/46, 420m	
			9	Kolkhoznik	1931		5320t, 91.3x13.2x2.8m, 950hp, 8.2kts; 2x1-100/56, 2x1-45/46, m	
MLR	Silny	1	1	Silny	1910		300t, 55.7x16.6x1.5m, 1b,1vc, 450hp, 10kts, 71p; 3x1-45/46, 100m	
ANL	-	2	1	Profsoyuz	1912		1535t, 67.0x11.5x2.8m, 520hp, 8kts; 1x1-45/46, nets	
			2	Garibaldi	1903		200t	
MS	Inzhener-Mekhanik Zverev	1	1	Martynov (TS)	1906		540t, 63.6x7.0x2.7m, 4b,2vte, 6000hp, 27kts, 65p; 2x1-75/50, MS, 16m	
			Minrep	1	2	Zapal	1912	
	Iskra	2	3	T-890	1914		420t, 44.5x7.5x3.3m, 1b,1vte, 650hp, 11.6kts, 49p; 1x1-76/30, 1x1-45/46, MS	
			4	T-891	1914			
	Udarnik	2	5	Udarnik	1917		220t, 43.6x6.1x1.7m, 2b,2vte, 400hp, 11kts, 35p; 1x1-76/30, 1x1-45/46, MS, 36m	
			6	Klyuz	1917			
	pr. 3		8	7	T-201 Zaryad	1936		445t, 62.0x7.2x2.0m, 2d, 2800hp, 18.5kts, 42p; 1x1-100/51, 1x1-45/46, 2x1-12.7, 2DCR, 31m, MS
				8	T-202 Buy	1938		
				9	T-203 Patron	1938		
				10	T-204 Fugas	1936		
				11	T-401 Tral	1936		
				12	T-402 Minrep	1937		
				13	T-403 Gruz	1937		
				14	T-404 Shchit	1937		
				15	T-1 Strela	1938		
				16	T-2 Tros	1938		

pr. 53	10	17	T-3 Podsekatel	1938		503t, 62.0x7.2x2.3m, 2d, 2800hp, 17.8kts, 44p; 1x1-100/56, 1x1-45/46, 2x1-12.7, 2DCR, 31m, MS
		18	T-4 Provodnik	1938		
		19	T-7 Vekha	1938		
		20	T-8 Cheka	1938		
		21	T-405 Vzryvatel	1938		
		22	T-406 Iskatel	1938		
		23	T-407 Mina	1938		
		24	T-411 Zashchitnik	1938		
pr. 53u	6	25	T-205 Gafel	1939		480t, 62.0x7.4x2.2m, 2d, 2900hp, 18.2kts, 47p; 1x1-100/56, 1x1-45/46, 2x1-12.7, 2DCR, 31m, MS
		26	T-206 Verp	1939		
		27	T-207 Shpil	1939		
		28	T-208 Shkiv	1939		
		29	T-210 Gak	1939		
		30	T-213 Krambol	1939		
pr. 58	5	31	T-5 Paravan	1938		459t, 62.0x7.2x2.1m, 2d, 2900hp, 18.5kts, 47p; 1x1-100/56, 1x1-45/46, 2x1-12.7, 2DCR, 31m, MS
		32	T-6 Kapsyul	1939		
		33	T-408 Yakor	1939		
		34	T-409 Garpun	1939		
		35	T-410 Vzryv	1939		
		1	T-899	1935		1150t, 55.1x9.0x5.8m, 1b,1vte, 650hp, 10.3kts; 2x1-45/46, MS
		2	T-898	1935		1150t, 55.1x9.0x5.8m, 1b,1vte, 650hp, 10.3kts; 2x1-45/46, MS
		3	T-894	1933		1287t, 53.4x9.0x4.8m, 1b,1vte, 675hp, 11kts; 2x1-45/46, MS
		4	T-897	1935		1050t, 49.5x9.0x5.0m, 1b,1vte, 650hp, 10kts; 2x1-45/46, MS
		5	T-896	1931		1200t, 54.0x9.0x4.5m, 1b,1vte, 650hp, 8.5kts; 2x1-45/46, MS
		6	T-895	1933		1200t, 53.4x9.0x4.2m, 1b,1vte, 650hp, 8.5kts; 2x1-45/46, MS
		7	No11	1931		1306t, 51.1x9.0x4.8m, 1b,1vte, 675hp, 9.7kts; 1x1-102/60, MS
		8	No12	1933		1250t, 54.8x9.4x5.0m, 1b,1vte, 650hp, 8.5kts; 1x1-102/60, MS
		9	No13	1930		1250t, 54.8x9.0x4.4m, 1b,1vte, 770hp, 10kts; 1x1-102/60, MS
		10	No14	1930		1107t, 49.3x8.5x4.8m, 1b,1vte, 675hp, 9kts; 1x1-102/60, MS
		11	No35	1936		140t
		12	No37	1936		140t
		13	No101	1938		140t
		14	No102	1938		140t

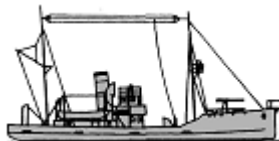
AMS	-	44	15	No38	1936		140t			
			16	No39	1936		140t			
			17	No65	1938		140t			
			18	No63	1937		140t			
			19	No21	1935		140t			
			20	No23	1935		140t			
			21	No26	1936		140t			
			22	No29	1936		140t			
			23	No33	1936		140t			
			24	No34	1936		140t			
			25	No31	1936		140t			
			26	No103	1938		140t			
			27	No104	1938		140t			
			28	No30	1936		140t			
			29	Dzerzhinskiy	1934		470t			
			30	Ordzhonikidze	1934		470t			
			31	Menzhinskiy	1934		460t			
			32	Moskva	1891		220t			
			33	Ozernoy			200t			
			34	Vidlitsa	1928		199t			
			35	Zmey	1914		245t			
			36	Buyok	1900		325t			
			37	Moroz	1914		350t			
			38	Barometr	1914		230t			
			39	T-893	1933		450t			
			40	T-892	1933		450t			
			41	No15	1921		480t			
			42	No16	1921		480t			
			43	No18	1935		447t			
			44	No19	1935		447t			
			AMSR	-	4	1	RTShch-1	1934		293t
						2	RTShch-2	1934		293t
						3	RTShch-3	1934		293t
						4	RTShch-4	1931		293t
			MSB	R	19	1 - 19	No221-225, 227, 311, 312, 314, 315, 326, 327, 411-413, 415, 422, 424, 425	1937		30t, 20.8x3.3x1.1m, 1d, 136hp, 9.3kts, 12p; MS

## BOARD GUARD SHIPS

		1	PSK-1 Dzerzhinskiy	1935		1161t, 80.0x8.3x3.8m, 3d, 4500hp, 18.5kts, 131p; 3x1-102/60, 4x1-45/46, 3x1-12.7,
pr. 19	2					

FS			2	PSK-2 Kirov	1935		2DCT, 24m
	pr. 43	4	3	PSK-301 Zhemchug	1937		580t, 62.0x7.2x3.0m, 2d, 2200hp, 17.2kts, 61p; 1x1-102/60, 2x1-45/46, 2x1-12.7, 2DCT, 31m
			4	PSK-2 Rubin	1936		
			5	PSK-303 Brilliant	1937		
			6	PSK-304 Sapfir	1937		
PC	Atarbekov	1	1	Atarbekov	1916		273t, 39.2x5.8x2.4m, 2d, 1600hp, 14kts, 46p; 2x1-76/55, 2x1-12.7
	Mogilevskiy	1	2	Mogilevskiy	1916		202t, 30.5x5.8x2.7m, 1b,1vte, 350hp, 11kts, 46p; 2x1-75/50
	T.13	1	3	PS-1	1916		580t, 43.2x7.2x3.5m, 1b,1vte, 500hp, 11kts, 35p; 1x1-57/50, MS, 30m
APC	-	2	1	Sovetskiy Azerbaydzhan	1893		1091t, 74.8x9.6x4.0m, 640hp, 14kts; 2x1-130/55
			2	Vorovskiy	1901		3315t, 96.6x12.2x5.5m, 6000hp, 18kts; 2x1-120/45
PS	MO-1	1	1	PK-139	1935		51t, 26.0x3.8x1.2m, 3pe, 1130hp, 14kts, 21p; 2x1-12.7, 2DCR
	MO-2	25	2 - 26	PK-115, 117, 124, 126-128, 140, 171-177, 216, 217, 225-231, 261, 262	1935 - 1936		50t, 26.2x3.9x1.5m, 3pe, 2250hp, 26kts, 21p; 2x1-45/46, 2x1-12.7, 2DCR
	MO-3	4	27 - 30	PK-73-76	1935		55t, 26.2x4.0x1.2m, 3pe, 2065hp, 24kts, 21p; 2x1-45/46, 2x1-12.7, 2DCR
	MO-4	92	31 - 122	PK-1-42, 61-66, 77, 78, 91-102, 116, 118-123, 125, 129-138, 141-148, 204, 212, 213, 219	1937 - 1939		57t, 26.9x4.0x1.5m, 3pe, 2550hp, 25.5kts, 21p; 2x1-45/46, 2x1-12.7, 2DCR
YP	K-105	3	1 - 3	K-105, 108, 240	1928	No picture	29t, 22.6x3.8x1.5m, 300hp, 12kts, 13p; 1x1-45/46
	K-1	5	4 - 8	K-391 - 395	1928	No picture	15t, 12.9x2.9x1.4m, 100hp, 8kts, 9p
	GK-1	2	9, 10	K-230, 231	1930	No picture	20t, 22.5x3.9x1.1m, 2pe, 1000hp, 23kts, 13p; 1x1-12.7
	ZK	15	11 - 25	K-193-196, 206-208, 220, 325-331	1931 - 1932		19t, 19.8x3.3x1.2m, 2pe, 600hp, 16kts, 12p; 1x1-45/46
	K-229	1	26	K-229	1931	No picture	23t, 22.5x3.9x1.3m, 1700hp, 12p; 1x1-12.7
	GK	2	27, 28	K-232, 233	1931		30t, 24.0x3.9x1.1m, 2pe, 1650hp, 23kts, 10p; 1x1-45/46
	K-17	1	29	K-396	1931	No picture	17t, 18.9x3.6x1.4m, 600hp, 11kts, 9p
	K-164	1	30	K-164	1932	No picture	14t, 12.9x2.7x1.2m, 100hp, 9.9kts, 7p
	K-18	1	31	K-397	1932	No picture	14t, 13.6x2.8x1.7m, 300hp, 7kts

BK-02	1	32	PK-224	1934	No picture	75t, 26.9x4.0x1.9m, 3pe, 2550hp, 18kts, 20p; 2x1-45/46, 2x1-12.7, 2DCR, 4m
KM-II	51	33 - 83	K-161-168, 188-190, 212-218, 221-226, 228, 236, 238, 241, 242, 277-284, 288, 289, 292, 294, 295, 298, 316-318, 336-338, 340, 387	1935 - 1937	No picture	7t, 13.8x3.1x0.8m, 1pe, 63hp, 9kts, 10p
KM-IV	8	84 - 91	K-186, 187, 191, 211, 227, 235, 388, 389	1938 - 1939		12t, 19.3x3.4x0.8m, 2pe, 126hp, 10kts, 10p
K-165	1	92	K-165	1935	No picture	16t, 17.0x3.4x0.8m, 720hp, 13kts, 7p
K-219	1	93	K-219	1930s	No picture	
PK-2	1	94	K-386	1936	No picture	15t, 15.3x2.9x1.4m, 300hp, 12kts, 12p

© Ivan Gogin, 2011-14

[home](#)[World navies yesterday](#)[1940](#)

# Spain 01 January 1940

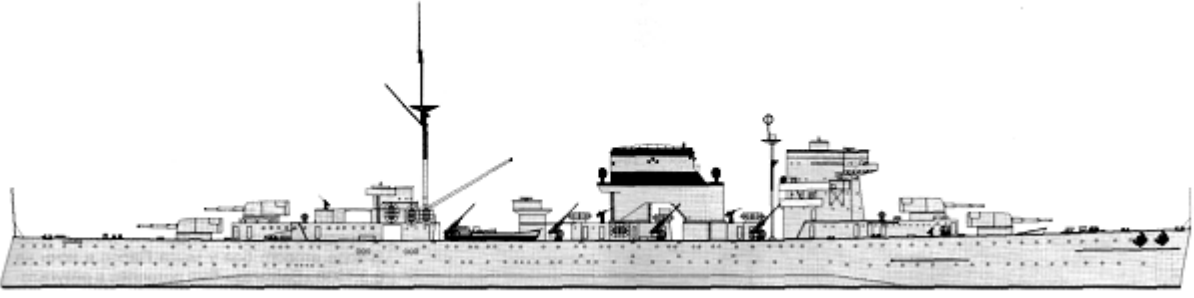
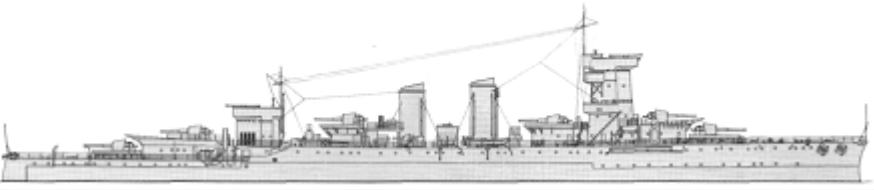
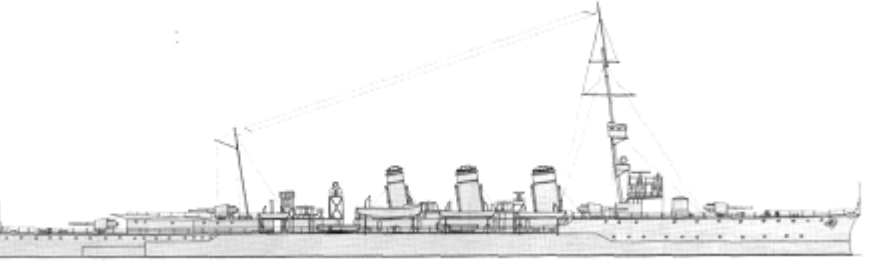
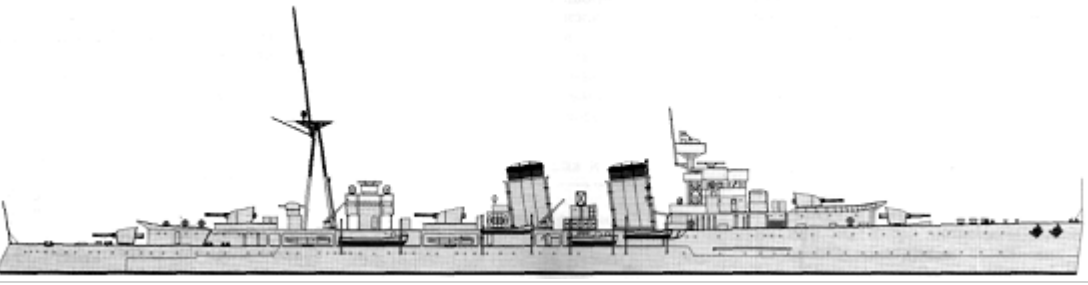

## CRUISERS

CA	Canarias	1	1	Canarias	1936		13070t, 193.6x19.5x5.3m, 8b,4gt, 90000hp, 33kts, 1200p; 51belt, 102magazines, 37deck, 25turrets, 25CT; 4x2-203/50, 8x1-120/45, 4x1-40/39, 2x2-37/83, 4x1-20/65, 2DCT, 1DCR
CL	Reina Victoria Eugenia	1	1	Navarra	1923		6450t, 140.8x15.2x4.8m, 8b,2t, 25500hp, 25kts, 404p; 50belt, 38deck, 152shields, 152CT; 6x1-152/50, 4x1-88/45, 4x1-20/70
	Méndez Núñez	1	2	Méndez Núñez	1924		6045t, 140.8x14.1x4.4m, 12b,4gt, 45000hp, 29kts, 343p; 76belt, 25deck, 150CT; 6x1-152/50, 1x1-76/19, 3x1-20/70, 4x3-533TT
	Príncipe Alfonso	3	3	Galicia	1925		9237t, 176.6x16.5x5.0m, 8b,4gt, 80000hp, 33kts, 564p; 76belt, 50deck, 13shields, 150CT; (3x2+2x1)-152/50, 4x1-105/45(4), 3x1-102/45, 2x1-76/35(3,5), 2x1-40/56(3), 1x1-40/56(5), 1x2-25/60(3), 4x1-20/70(3), 2x1-20/70(5), 4x1-20/65(4), 4x2-13.2(3), 4x3-533TT
			4	Almirante Cervera	1927		
5			Miguel de Cervantes	1930			
		1	Mar	1930			



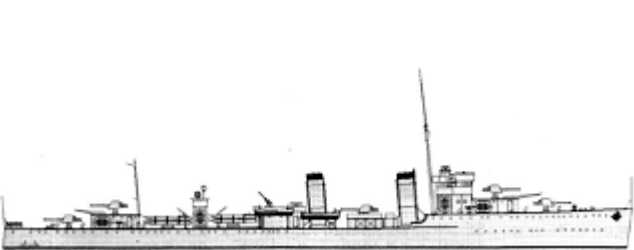
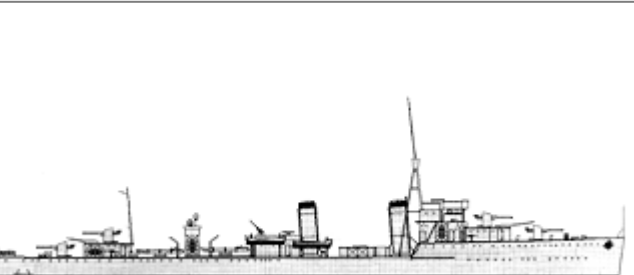
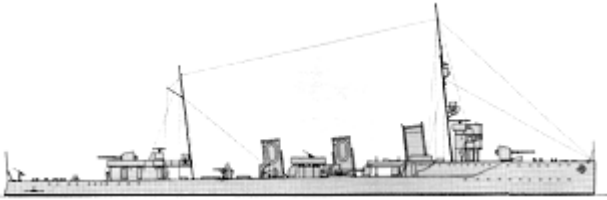

AMC	-	2	Cantábrico			20/65
		2	Mar Negro	1930		6632brt, 128.5x16.5xm, 2d, 14kts; 4x1-152/45, 4x1-76/40, 3x1-20/65

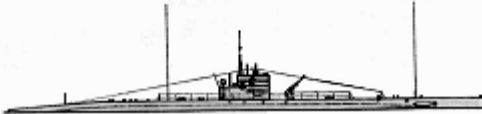

## TORPEDO SHIPS

DD	Alsedo	1	Alsedo	1924		1337t, 86.8x8.2x4.5m, 4b,2gt, 33000hp, 34kts, 86p; 3x1-102/50(2), 3x1-102/45(1,3), 2x1-47/50(1,3), 3x1-20/65(2), 2x2-450TT, 2DCT(2), 1DCR, 60m	
		2	Velasco	1924			
		3	Lazaga	1925			
	Churucca	6	4	Sánchez Barcáiztegui	1928		2087t, 102.0x9.7x3.2m, 4b,2gt, 42000hp, 36kts, 190p; 4x1-120/45, 1x1-76/45, 2x1-40/39(5), 1x1-40/39(9), 1x1-25/60(6,7), 2x1-20/70(5), 2x3-533TT, 2DCR
			5	José Luis Díez	1929		
			6	Lepanto	1930		
			7	Churucca	1931		
			8	Alcalá Galiano	1931		
	Almirante Antequera	7	9	Almirante Valdés	1933		2175t, 101.2x9.7x3.2m, 4b,2gt, 42000hp, 36kts, 190p; 4x1-120/45(10,11,13-16), 1x1-102/50(11), 5x1-102/50(12), 1x1-76/45, 1x2-25/60(16), 2x3-533TT, 2DCR
			10	Almirante Antequera	1935		
			11	Almirante Miranda	1936		
			12	Gravina	1936		
			13	Escaño	1936		
			14	Císcar	1936		
	Melilla	2	15	Jorge Juan	1937		1820t, 94.7x9.5x3.4m, 5b,2t, 40000hp, 34kts, 160p; 2x2-120/45, 2x1-76/40, 4x1-20/65, 2x2-450TT, 50m, 1DCR
			16	Ulloa	1937		
	Huesca	2	17	Melilla	1917		1216t, 85.0x8.0x2.8m, 3b,2t, 20000hp, 31.5kts, 137p; 5x1-102/45(19), 6x1-102/45(20), 1x1-40/39, 2x1-20/65, 2x1-13.2, 2x2-450TT, 42m
18			Ceuta	1920			
TB	T-1	6	19	Huesca	1915		190t, 52.3x5.0x1.5m, 2b,3(1)-2(2-6)t, 3750hp, 26kts, 31p; 3x1-47/50, (1x2+1x1)-450TT, 20m(3,4,6)
			20	Teruel	1915		
			1	T-7	1915		
			2	T-9	1915		
			3	T-14	1916		
			4	T-16	1917		
5	T-17	1917					
6	T-19	1920					

## SUBMARINES

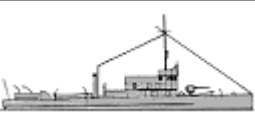

B1	4	1	B1	1922		556/740t, 64.2x5.6x3.4m, 2d/em, 1400/420hp, 16.2/10.5kts, 28p, 60m; 1x1-76/45, 4-450TT	
		2	B2	1922			
		3	B3	1922			
		4	B4	1923			
SS	C1	3	5	C1 Isaac Peral	1928		915/1143t, 75.3x6.3x4.1m, 2d/em, 2000/750hp, 16.5/8.5kts, 40p, 90m; 1x1-76/45(5,6), 1x1-76/50(7), 6-533TT
			6	C2	1928		
			7	C4	1929		
General Mola	2	8	General Mola	1934		970/1239t, 70.5x6.9x4.1m, 2d/em, 3000/1100hp, 17/8kts, 55p, 90m; 2x1-100/43, 2x1-13.2, 8-533TT	
		9	General Sanjurjo	1934			

## ESCORTS





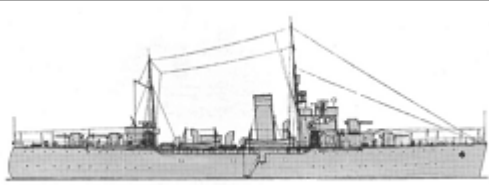
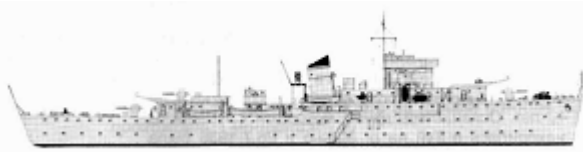

Uad Lucus	1	1	Uad Martin	1917		547t, 40.8x7.2x2.8m, 1b,1vte, 480hp, 10.5kts, 39p; 1x1-76/50
		2	Alhucemas	1918		
Uad Kert	3	3	Uad Kert	1917		665t, 45.1x7.2x2.8m, 1b,1vte, 600hp, 11kts, 45p; 1x1-76/50(3,5), 2x1-76/50(4), 1x1-47/50(5)
		4	Arcila	1918		
		5	Xauen	1918		
Alcázar	3	6	Alcázar	1919		440t, 41.0x7.3x3.2m, 1b,1vte, 425hp, 11kts, 41p; 1x1-76/50, 1x1-57/42(9), 2x1-47/50(7)
		7	Larache	1919		
		8	Tetuán	1919		
APC -	2	1	Ciudadela	1896		270t
		2	Virgen de Begoña	1919		368t
FPV	6	1	Condestable Zaragoza	1919	No picture	150t, 24.5x6.0x2.7m, 1b,1vte, 300hp, 11kts, 11p; 1x1-76/50 or 1x1-57/42
		2	Cabo de Infantería Marina Garciolo	1919		
		3	Contramaestre Castelló	1919		
		4	Maquinista Macías	1919		
		5	Fogonero Bañobre	1919		
		6	Marinero Jarana	1919		
Lanzón	1	7	Lanzón 1	1935	No picture	111t, 26.5x5.4x3.1m, 1pe, 285hp, 12kts

## OTHER FIGHTING SHIPS

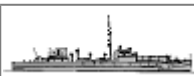
Recalde	1	1	Lauria	1912		811t, 65.5x9.1x3.0m, 2b,2vte, 1200hp, 13.5kts, 130p; 4x1-76/50
---------	---	---	--------	------	--	--

PG	Antonio Cánovas del Castillo	3	2	Cánovas del Castillo	1923		1335t, 77.3x10.2x3.4m, 2b,2vte, 1700hp, 15kts, 132p; 4x1-102/45, 2x1-76/40, 1x1-20/70
			3	Canalejas	1924		
			4	Dato	1925		
	Calvo Sotelo	1	5	Calvo Sotelo	1938		2000t, 92.4x12.2x3.5m, 2b,2gt, 6500hp, 18.5kts, 160p; 3x1-120/45, 2x1-57/42, 1x1-20/65, 2x1-13.2, 2DCR; 500troops
PR	Cabo Fradera	1	1	Cabo Fradera	1928		45t, 22.8x4.4x1.2m, 2pe, 121hp, 10.7kts, 16p; 1x1-42/42

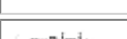
### COASTAL FORCES

PT	Falange	3	1-3	LT11, 13, 14	1932		58t, 27.9x4.5x1.5m, 3d/1pe, 3000/100hp, 33.8kts, 13p; 1x1-20/65, 2-533TT, 3m or 6DC
	Badajoz	1	4	LT12	1930		52t, 26.9x4.4x1.4m, 3pe/1pe, 2700/100hp, 34.2kts, 12p; 1x1-20/65, 2-533TT, 3m or 6DC
	Núm11	2	5, 6	LT15, 16	1937		17t, 19.1x3.3x1.2m, 2pe, 2000hp, 50kts, 7p; 2-533TT
	Nápoles	1	7	LT17	1918		13t, 16.2x2.8x1.4m, 2pe/em, 500/10hp, 29.5kts, 8p; 2-450TT, 4DC
	Sicilia	1	8	LT18	1918		13t, 16.4x2.9x1.4m, 2pe, 500hp, 26kts, 8p; 2-450TT, 4DC
	Cándido Pérez	1	9	LT19	1930		16t, 16.0x3.3x1.1m, 2pe, 1500hp, 40kts, 13p; 1x1-13.2, 5DC
YP	DAR11	14	1-14	LAS11-18, 21-26	1937 - 1938	No picture	20t, 13.0x2.9x0.8m, 1pe, 800hp, 30kts, 7p, 1DCR
YP(Ta)	C.I	18	1-18	C1, 2-4, 6-16, 18-21	1922-1925	No picture	36t, 22.8x4.0x1.4m, 2d, 180hp, 12kts, 6p
	I1	5	19	I1	1923	No picture	128t, 33.5x2.6x1.8m, 2d, 600hp, 13kts; 1x1-47/50 or 1x1-42/42
			20	I2	1923		
			21	I3	1923		
			22	I4	1923		
			23	I6	1923		

### AMPHIBIOUS SHIPS AND CRAFTS

LCT	K1	15	1	K2	1915		160t, 32.2x6.4x1.5m, 1sd, 60hp, 8kts, 15p; 300troops or 150t cargo
			2	K8	1915		
			3	K9	1915		
			4	K10	1915		
			5	K12	1915		
			6	K13	1915		
			7	K14	1915		
			8	K15	1915		
			9	K28	1915		
			10	K18	1915		

			11	K19	1915
			12	K20	1915
			13	K23	1915
			14	K25	1915
			15	K26	1915

### MINE WARFARE SHIPS AND CRAFTS

ML	Júpiter	4	1	Júpiter	1937		2600t, 96.0x12.7x3.5m, 4b,2gt, 10000hp, 18.5kts, 180p; 4x1-120/45, 2x1-88/45(2), 2x1-76/40(1,3,4), 3x1-20/65, 264m, 2DCR
			2	Vulcano	1937		
			3	Marte	1938		
			4	Neptuno	1939		

© Ivan Gogin, 2011-14

[home](#)[World navies yesterday](#)[1930](#)

# SWEDEN 01 January 1940

## CAPITAL SHIPS

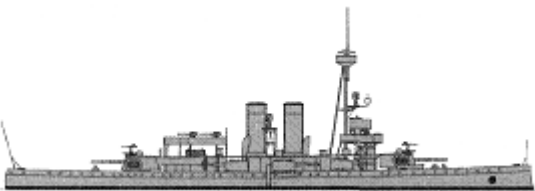
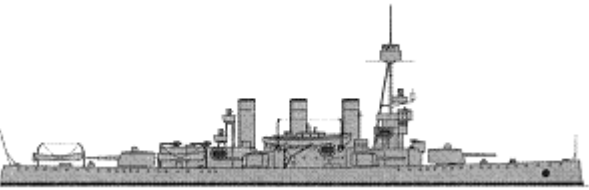
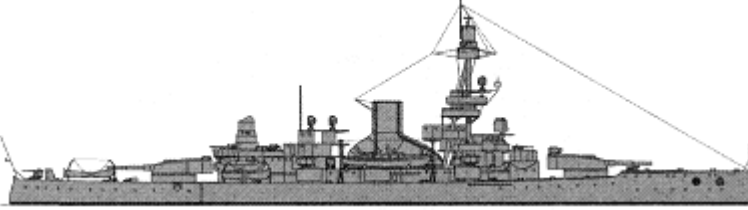
Äran	4	1	Äran	1902		3735t, 89.7x15.0x5.0m, 8b, 2vte, 6500hp, 17kts, 275p; 175belt, 48deck, 190turrets, 200CT; 2x1-210/44, 6x1-152/44, 10x1-57/55, 2x1-37/35, 2-450TT	
		2	Wasa	1902			
		3	Tapperheten	1903			
		4	Manligheten	1904			
BC	Oscar II	1	5	Oscar II	1907		4850t, 95.6x15.4x5.5m, 10b, 2vte, 9400hp, 18kts, 331p; 150belt, 50deck, 190turrets, 157CT; 2x1-210/44, 4x2-152/50, 2x2-75/60, 3x1-37/35, 1x2-25/58
Sverige	3	6	Sverige	1917		7516(6)-7633(7, 8)t, 120.0(6)-121.6(7, 8)x18.6x6.3(6)-6.2(7, 8)m, 12b(6, 7)-8b(8), 4t(6)-2gt(7, 8), 25400(6)-23910(7, 8)hp, 22.5kts, 427p; 200belt, 45deck, 200turrets, 175CT; 2x2-283/45, (1x2+6x1)-152/50(6, 7), (1x2+4x1)-152/50(8), 2x2-75/60, 2x1-57/55, 2x2-40/56(8), (2x2+4x1)-25/58(8), 3x1-25/58(7)	
		7	Drottning Victoria	1921			
		8	Gustaf V	1922			



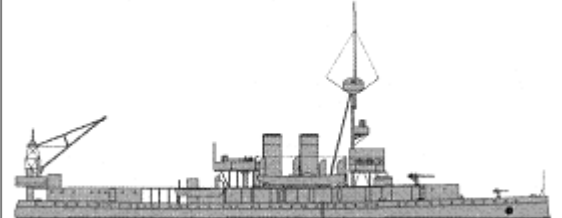

## AIRCRAFT CARRYING SHIPS

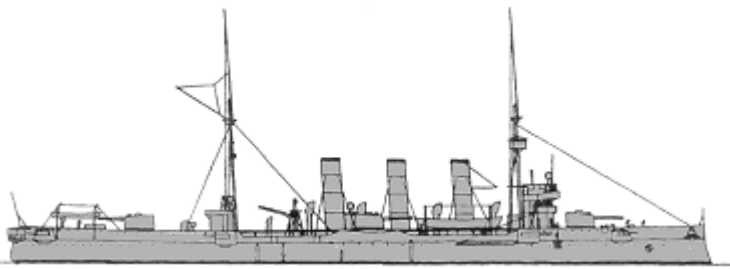
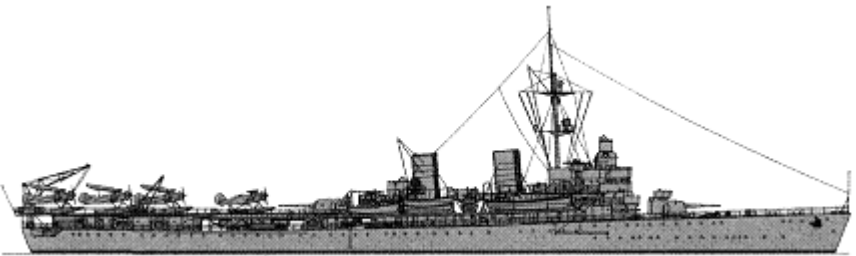
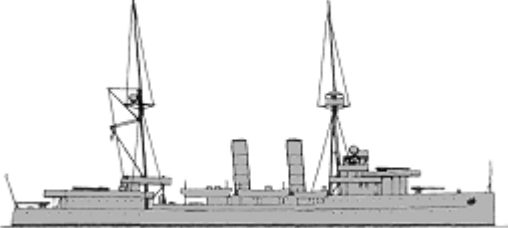
AV	Dristigheten	1	1	Dristigheten	1901		3600t, 89.0x14.8x5.2m, 8b, 2vte, 5600hp, 16.8kts, 275p; h: 200belt, 50deck, 247CT; 4x1-75/50, 3seaplanes (3 Osprey)
----	--------------	---	---	--------------	------	--	---

## CRUISERS

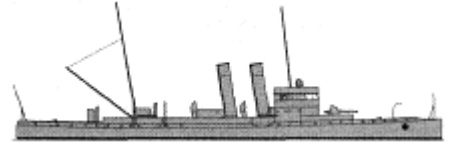
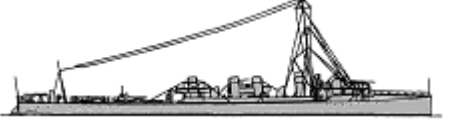

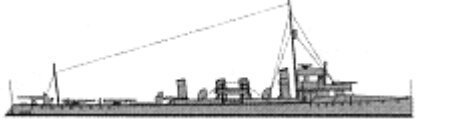
CA	Fylgia	1	1	Fylgia	1907		4734t, 115.1x14.8x6.3m, 12b, 2vte, 12000hp, 21.5kts, 320p; 100belt, 35deck, 125turrets, 100CT; 4x2-152/50, 14x1-57/55, 2-450TT
CL	Gotland	1	1	Gotland	1934		5550t, 134.8x15.4x4.5m, 4b, 2gt, 33000hp, 27.5kts, 480p; 24belt, 25deck, 25turrets, 19CT; (2x2+2x1)-152/55, (1x2+2x1)-75/60, (1x2+4x1)-25/58, 2x3-533TT, 100mines, 8seaplanes (6 Osprey)
CM	Clas Fleming	1	1	Clas Fleming	1914		1800t, 80.2x10.4x4.3m, 8b, 2t, 6500hp, 20kts, 160p; 25deck, 75CT; 4x1-120/50, 100mines

## TORPEDO SHIPS

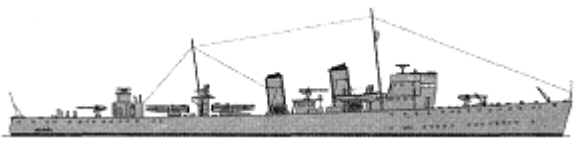
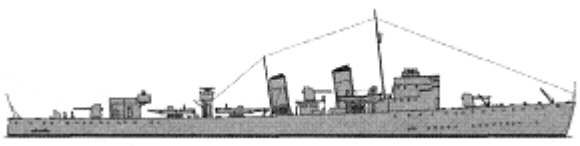
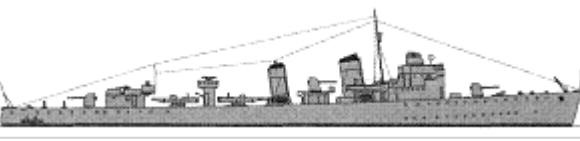
PGT	Örnen	1	Örnen	1897		814-844t, 67.7x8.2x3.1m, 8b, 2vte, 4000hp, 20kts, 113p; 19deck; 2x1-120/45, 4x1-57/55, 1-380TT
		2	Jacob Bagge	1898		
	Wale	1	Wale	1908		461t, 66.1x6.3x2.8m, 4b, 2vte, 7665hp, 30kts, 54p; 2x1-75/50, 4x1-57/55, 2x2-450TT
	Ragnar	2	Vidar	1910		460t, 66.1x6.3x2.7m, 4b, 2vte, 7200hp, 30kts, 54p; 4x1-75/50, 2x2-450TT
		3	Ragnar	1909		
		4	Sigurd	1909		
	Hugin	5	Hugin	1911		500t, 66.3x6.5x3.5m, 4b, 2t, 10000hp, 33kts, 72p; 4x1-75/50, 2x2-450TT
		6	Munin	1913		
DD	Wrangel	7	Wrangel	1918		498t, 72.0x6.9x2.8m, 4b, 2gt, 13000hp, 34kts, 81p; 4x1-75/50, (2x2+2x1)-450TT
		8	Wachtmeister	1918		
		10	Ehrensköld	1927		

Ehrensköld	2	11	Nordenskjöld	1927		1160t, 91.4x8.9x3.8m, 3b, 2gt, 24000hp, 36kts, 120p; 3x1-120/45, 2x2-25/58, 2x3-533TT, 2DCT, 2DCR, 20mines
		12	Klas Horn	1932		
	Klas Horn	2	13	Klas Ugglå	1932	
14			Göteborg	1936		
Göteborg	3	15	Stockholm	1937		1184t, 94.6x9.0x3.8m, 3b, 2gt, 32000hp, 39kts, 155p; 3x1-120/45, 2x2-25/58(14, 15), 3x2-25/58(16), 2x3-533TT, 2DCT, 2DCR, 20mines
		16	Malmö	1939		

## SUBMARINES

SS	Hajen	3	1	Hajen	1920		422/600t, 54.0x5.2x3.5m, 2d/em, 2000/700hp, 15.5/9kts, 30p, 30m; 1x1-57/55, 4-450TT
			2	Sälen	1920		
			3	Valrossen	1920		
	Bävern	3	4	Bävern	1921		472/650t, 57.0x5.8x3.0m, 2d/em, 2100/520hp, 15.2/8.2kts, 28p, 30m; 1x1-57/55, 4-450TT
			5	Illern	1921		
			6	Uttern	1921		
	Valen	1	7	Valen	1925		548/730t, 57.1x7.1x3.1m, 2d/em, 1340/700hp, 14.8/7.4kts, 31p, 60m; 1x1-75/50, 1x1-25/58, 4-450TT, 20mines
	Draken	3	8	Draken	1929		750/850t, 66.2x6.4x3.3m, 2d/em, 1920/1000hp, 13.8/8.3kts, 35p, 60m; 1x1-105/41, 1x1-25/58, 4-533TT
			9	Gripen	1929		
			10	Ulven	1931		
	Delfinen	3	11	Delfinen	1936		540/720t, 63.1x6.4x3.4m, 2d/em, 1200/800hp, 15/9kts, 34p, 60m; 1x1-57/55, 1x1-25/58, 4-533TT, 20mines
			12	Nordkaperen	1936		
			13	Springaren	1937		
	Sjölejonet	3	14	Sjölejonet	1938		580/760t, 64.2x6.4x3.4m, 2d/em, 2100/1000hp, 16.2/10kts, 38p, 60m; 2x1-40/43, (4+1x2)-533TT
			15	Sjöbjörnen	1939		
			16	Sjöhunden	1939		

## ESCORTS

Komet	7	1	V27	1898		120t, 39.8x4.8x2.5m, 1b, 1vc, 1300hp, 23kts, 18p; 2x1-37/39, MS
		2	V28	1899		
		3	V30	1900		
		4	V33	1902		
		5	V34	1902		
		6	V35	1903		
		7	V36	1903		
		8	V39	1908		

PC	Plejad	16	9	V40	1908		106t, 40.2x4.4x2.6m, 2b, 1vte, 2000hp, 26kts, 25p; 2x1-57/55, MS
			10	V41	1908		
			11	V42	1908		
			12	V43	1909		
			13	V44	1909		
			14	V45	1909		
			15	V46	1909		
			16	V47	1909		
			17	V48	1910		
			18	V49	1910		
			19	V50	1910		
			20	V51	1909		
			21	V52	1909		
			22	V53	1910		
			23	V54	1910		
			Jägaren	4	24		
	25	Kaparen			1934		
	26	Väktaren			1935		
	27	Snapphanen			1936		
	-	4	28	Granat	1925		440t
			29	Harpun	1925		440t
			30	Styrbjörn	1923		350t
			31	Starkodder	1925		357t

## COASTAL FORCES

PT	Mtb3	2	1, 2	Mtb3, 4	1925		12.5t, 16.2x3.4x1.1m, 2pe, 750hp, 40kts, 7p; 2-450TT, 4DC
PB	Asköfjärd	3	1-3	V71 Asköfjärd, V72 Baggensfjärd, V73 Nämdöfjärd	1931 - 1932	No picture	25t, 19.3x3.8x1.5m, 1d, 92hp, 11.5kts, 7p; 1x1-37/39
	Edöfjärd	3	4-6	V74 Kanholmsfjärd, V75 Lidöfjärd, V76 Edöfjärd	1933	No picture	28t, 21.2x3.8x1.5m, 1d, 92hp, 11.5kts, 7p; 1x1-37/39

## MINE WARFARE

ML	Mul3	1	1	Mul3	1879	No picture	190t, 6.5kts; mines
	Mul5	4	2	Mul5	1904	No picture	120t, 7.5kts; mines
			3	Mul6	1904		
			4	Mul7	1904		
			5	Mul8	1905		
	Mul9	1	6	Mul9	1912	No picture	120t, 9.1kts; mines
Mul10	1	7	Mul10	1939	No picture	166t, 27.4x5.6x2.3m, 9.5kts; mines	

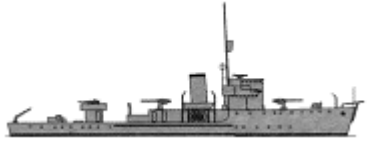

MS	Sökaren	3	1	Sökaren	1918	No picture	266t, 27.8x6.8x3.0m, 1b, 1vte, 465hp, 10kts, 17p; 1x1-57/21, mines, MS
			2	Sveparen	1918		
			3	Sprängaren	1918		
	Arholma	2	4	Arholma	1939		442t, 56.7x7.6x2.1m, 2b, 2gt, 3200hp, 17kts, 37p; 2x1-105/41, 2x1-25/58, 2DCT, mines
			5	Landsort	1939		
MSB	M1	2	1, 2	M1, 2	1938	No picture	62t, 30.0(1)-29.8(2)x4.3(1)-4.0(2)x1.0m, 3be(1)-3d(2), 600(1)-630(2)hp, 16.5(1)-18(2)kts, 11p; 1x1-13.2, DC, MS

© Ivan Gogin, 2010-14



[home](#)[World navies yesterday](#)[1940](#)

## Thailand 01 January 1940

### CAPITAL SHIPS

BC	Sri Ayuthia	2	1	Sri Ayuthia	1938		2265t, 76.5x14.4x4.2m, 2d, 5200hp, 15.5kts, 155p; 63belt, 63decks, 102turrets, 102CT; 2x2-203/50, 4x1-76/40, 4x1-40/62
			2	Dhonburi	1938		



### TORPEDO SHIPS

DD	Phra Ruang	1	1	Phra Ruang	1917		1208t, 83.6x8.3x2.7m, 3b,2gt, 27000hp, 36kts, 82p; 3x1-102/40, 1x1-76/40, 1x1-40/39, 2x2-533TT
TB	Trad	9	1	Trad	1936		470t, 68.0x6.4x2.1m, 2b,2gt, 9000hp, 31kts, 70p; 3x1-76/40, 2x1-20/65, (2x2+2x1)-450TT
			2	Puket	1936		
			3	Patani	1938		
			4	Surasdra	1938		
			5	Chandraburi	1938		
			6	Rayong	1938		
			7	Chunphorn	1938		
			8	Chonburi	1938		
			9	Songhkla	1938		
	Kantang	3	10	Kantang	1937		135t, 42.0x4.6x1.5m, 2b,2gt, 1000hp, 19kts, 31p; 1x1-76/40, 2x1-20/65, 1x2-450TT
			11	Klongyai	1937		
			12	Takbai	1937		

### SUBMARINES

SS	Vilun	4	1	Vilun	1937		370/430t, 51.0x4.1x3.7m, 2d/em, 1000/540hp, 14.5/8kts, 24p; 1x1-76/40, 1x1-13.2, 5-533TT
			2	Machanu	1937		
			3	Sinsamudar	1938		
			4	Blajunbol	1938		

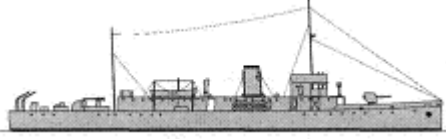

## ESCORTS

SL	Chow Phraya	1	1	Chow Phraya	1919		840t, 70.4x8.7x2.2m, 2b,2vte, 2200hp, 16kts, 65p; 1x1-102/40, 1x1-76/40
	Tachin	2	3	Tachin	1937		
				Meklong	1937		2000t, 82.0x10.4x3.1m, 2b,2vte, 2500hp, 17kts, 155p; 4x1-120/45, 2x1-20/65, 2x2-450TT, 1seaplane (WS-103), 20m, MS

## OTHER FIGHTING SHIPS

PG	Ratanakosindra	2	1	Ratanakosindra	1925		1000t, 53.0x11.3x3.3m, 2b,2vte, 850hp, 12kts, 102p; 57belt, 50deck, 38turrets, 120CT; 2x1-152/50, 4x1-76/40, 2x1-40/39
			2	Sukothai	1930		

## COASTAL FORCES

PT	No6	12	1-12	No6-17	1935-1937		16t, 16.8x3.4x1.2m, 2pe/1pe(2), 950/30hp, 40kts, 5p; 2-450TT, 1DCR
FPV	Sarasindhu	3	1-3	Sarasindhu, Thiew Uthock, Travane Vari	1935-1936		50t, 21.9x3.9x1.0m, 2d, 150hp, 9kts; 1x1-37/23

## MINE WARFARE SHIPS

ML	Bangrachan	2	1	Bangrachan	1936		408t, 50.0ppx7.7x2.2m, 2d, 540hp, 13kts, 55p; 2x1-76/40, 142m
			2	Nangsarai	1937		

[home](#)[World navies yesterday](#)[1940](#)

## Turkey 01 January 1940

### CAPITAL SHIPS

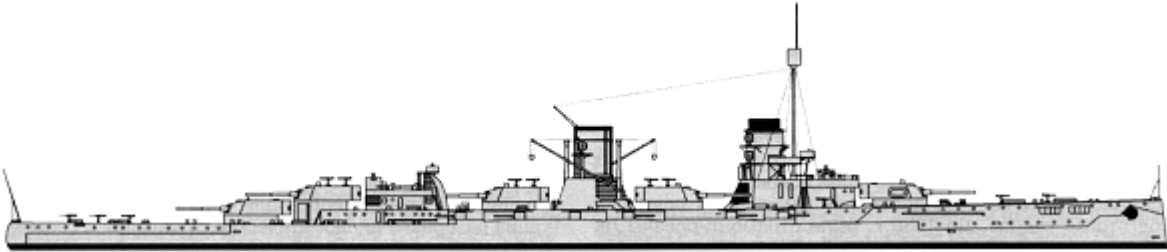

CB	Yavuz Sultan Selim	1	1	Yavuz	1912		25300t, 186.6x29.5x8.7m, 24b,4t, 52000hp, 25.5kts, 1053p; 270belt, 50deck, 230turrets, 350CT; 5x2-283/47, 10x1-150/45, 6x1-88/45, 10x1-40/39, 4x1-20/65, 2-500TT
----	--------------------	---	---	-------	------	--	--

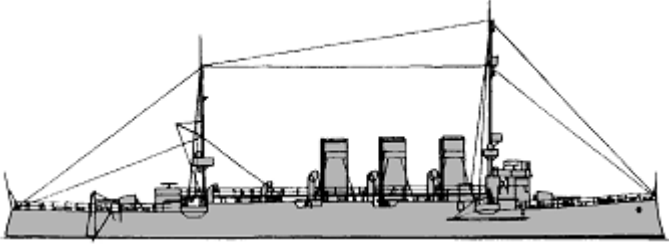
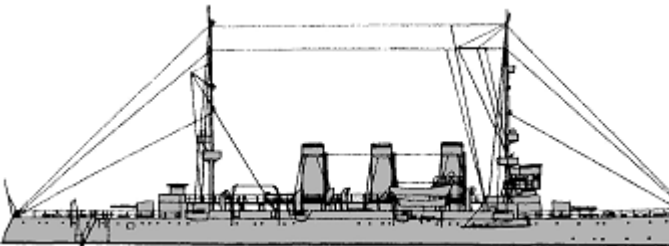
### CRUISERS



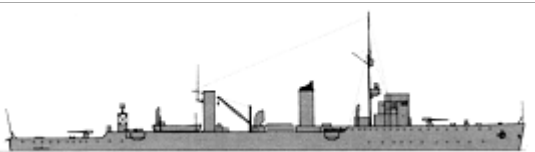

CL	Mecidiye	1	1	Mecidiye	1903		3967t, 102.4x12.8x4.8m, 16b,2vqe, 12500hp, 22kts, 312p; 38deck, 102slopes; 4x1-130/55, 4x1-76/50, 2-450TT
	Hamidiye	1	2	Hamidiye	1904		3904t, 112.0x14.5x4.88m, 6b,2vte, 12000hp, 22kts, 302p; 38deck, 102slopes; 2x1-150/45, 8x1-75/50, 2x1-450TT, 70m

### TORPEDO SHIPS



PGT	Peyk-i Şevket	2	1	Peyk	1907		775t, 80.1ppx8.4x4.6m, 4b,2vte, 5100hp, 18kts, 105p; 2x1-88/45, 6x1-57/40, 2x1-450TT, 25m(2)
-----	---------------	---	---	------	------	--	--

			2	Berk	1907		
DD	Kocatepe	1	Kocatepe	1931		1650t, 100.2x9.4x2.9m, 3b,2gt, 40000hp, 36kts, 149p; 4x1-120/50, 3x1-40/39, 2x3-533TT	
		2	Adatepe	1931			
	Zafer	3	Zafer	1932		1610t, 96.0x9.3x3.3m, 3b,2gt, 35000hp, 36kts, 149p; 2x2-120/50, 2x1-40/39, 2x3-533TT	
		4	Tinaztepe	1932			

## SUBMARINES

SS	İnönü	2	1	Birinci İnönü	1928		519/674t, 58.7x5.8x3.8m, 2d/em, 1100/700hp, 13.5/8.5kts, 44p, 50m; 1x1-75/55, 6-450TT
			2	İkinci İnönü	1928		
	Dumlupınar	1	3	Dumlupınar	1931		1192/1726t, 74.1x7.8x4.4m, 2d/em, 2300/1400hp, 17.5/9kts, 47p, 100m; 1x1-100/43, 6-533TT, 48m
	Sakarya	1	4	Sakarya	1931		815/1145t, 61.6x6.7x4.3m, 2d/em, 1500/1100hp, 16.9/9.5kts, 41p, 100m; 1x1-100/43, 6-533TT
	Gür	1	5	Gür	1934		755/965t, 72.4x6.4x4.2m, 2d/em, 2880/1000hp, 19.7/8.5kts, 42p, 100m; 1x1-105/45, 6-533TT
Saldıray	1	6	Saldıray	1939		934/1210t, 80.0x6.4x4.3m, 2d/em, 3500/1000hp, 20/9kts, 44p, 100m; 1x1-105/45, 6-533TT	

## COASTAL FORCES

PT	Doğan	3	1-3	Doğan, Denizkuşu, Martı	1931		32t, 21.0x4.2x1.0m, 3pe, 1500hp, 34kts, 10p; 1x1-75/55, 1x1-20/65, 2-450TR, 2DCR
YP	No1	3	1-3	No18, 21, Mülazım Hayati	1914		20t, 18.3ppx3.3x1.6m, 2pe(1), 70hp, 11.9kts, 6p; 1x1-37/37

## MINE WARFARE SHIPS

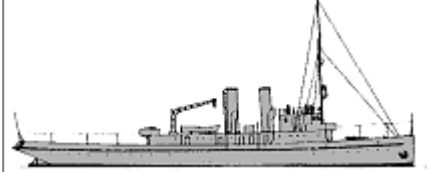
ML	Atak	1	1	Atak	1938	No picture	500t, 44.0x8.0x3.6m, 1d, 1025hp, 13kts; 40m
AML	-	1	1	İntibah	1886		616brt; 1x1-75/35, 50m

MS	İsa Reis	3	1	İsa Reis	1914		413t, 47.0x7.9x1.3m, 3b,2vte, 850hp, 14kts, 60p; 2x1-75/50, 2x1-47/50, MS
			2	Kemal Reis	1914		
			3	Hizir Reis	1914		
	Kavak	2	4, 5	Kavak, Çanak	1937	No picture	52t, 22.9x4.4x1.5m, 3pe, 1500hp, 15kts, 11p; MS

© Ivan Gogin, 2011-15

[home](#)[World navies yesterday](#)[1940](#)

## UNITED KINGDOM 01 January 1940

*IN SERVICE: 11 battleships, 3 battlecruisers, 3 monitors, 4 fleet aircraft carriers, 2 light aircraft carriers, 2 seaplane tenders, 13 heavy cruisers, 43 light cruisers, 1 cruiser-minelayer, 41 auxiliary cruisers, 18 destroyer leaders, 160 destroyers, 60 submarines, 34 sloops, 10 patrol ships (corvettes), 12 armed boarding vessels, 38 auxiliary patrol vessels, 7 auxiliary decoy vessels, 1 auxiliary seagoing AA vessel, 1 auxiliary coastal AA vessel, 67 armed yachts, 20 river gunboats, 24 motor torpedo boats, 21 motor anti-submarine boats, 17 small landing ships, 2 small landing barges, 10 landing crafts, 8 minelayers, 8 auxiliary minelayers, 2 netlayers, 45 minesweepers, 49 auxiliary minesweepers, 1 auxiliary mine destruction vessel, 79 minesweeping trawlers, 576 auxiliary armed trawlers, 6 minesweeping drifters, 58 auxiliary armed drifters, 6 armed whalers, 7 auxiliary armed whalers, 1 minesweeping boat*

### CAPITAL SHIPS AND MONITORS

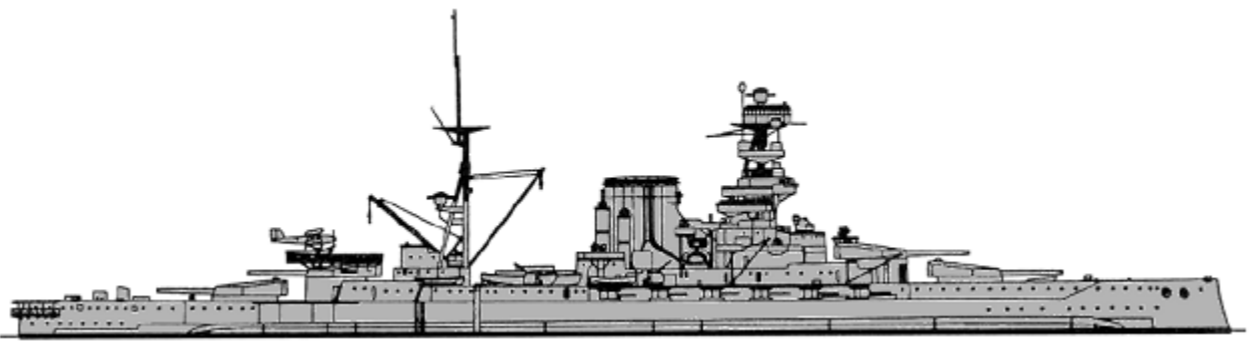
BB	Queen Elizabeth	1	Queen Elizabeth	1915		35710(1, 5)-36450(2)-36785(3)-36513(4)t, 196.8x31.7x8.8(1, 3, 5)-10.0(4)-10.1(2)m, 24b(1, 3, 5), 6b(2), 8b(4), 4t(1, 3, 5), 4gt(2, 4), 56000(1, 3, 5)-80000(2, 4)hp, 23.5(1, 2, 4, 5)-23(3)kts, 951p; 330mm belt, 330mm turrets, 102mm(1) 127mm(2-5) deck, 280mm(1, 3), 76mm(2, 4), 127mm(5) CT; 4x2-381/42, 12x1-152/45(1, 3, 5), 8x1-152/45(2), 10x2-114/45(4), 4x2-102/45(2, 3, 5), 4x1-102/45(1), 2x8-40/39(1, 3, 5), 4x8-40/39(2, 4), 2x4-12.7/62(3), 4x4-12.7/62(2, 4, 5), 2-533TT(1), 2seaplanes(2, 4) (1 Swordfish(2); 2 Swordfish(4)), 1seaplane(3, 5) (1 Swordfish (3); 2 Swordfish(5)); radar: type279(4)
		2	Warspite	1915		
		3	Barham	1915		
		4	Valiant	1916		
		5	Malaya	1916		
	Revenge	6	Revenge	1916		
		7	Royal Sovereign	1916		
		8	Resolution	1916		
		9	Ramillies	1917		
					32526(6, 8)-32474(7)-33500(9)t, 190.3x30.9(6, 8)-31.0(7)-31.1(9)x8.3(6, 8)-8.7(7)-8.4(9)m, 18b, 4gt, 40000hp, 22(6-8)-21.5(9)kts, 997p; 330mm belt, 330mm turrets, 102mm deck, 280mm CT; 4x2-381/42, 12x1-152/45, 4x2-102/45, 2x8-40/39, 2x4-12.7/62, 2-	

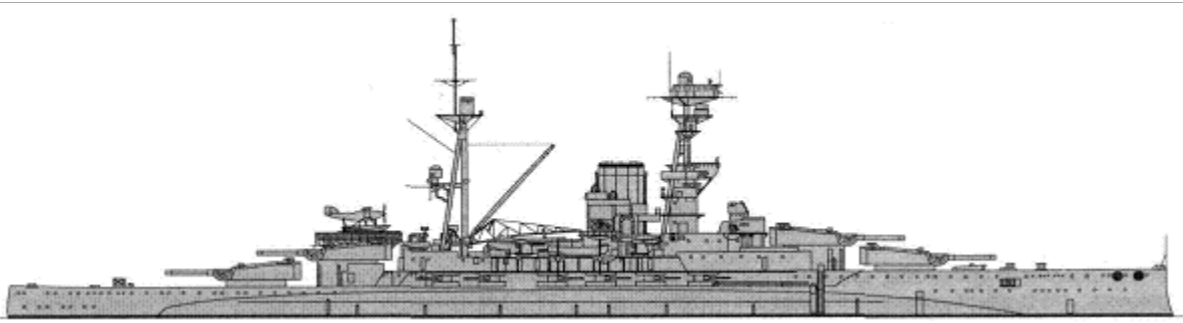
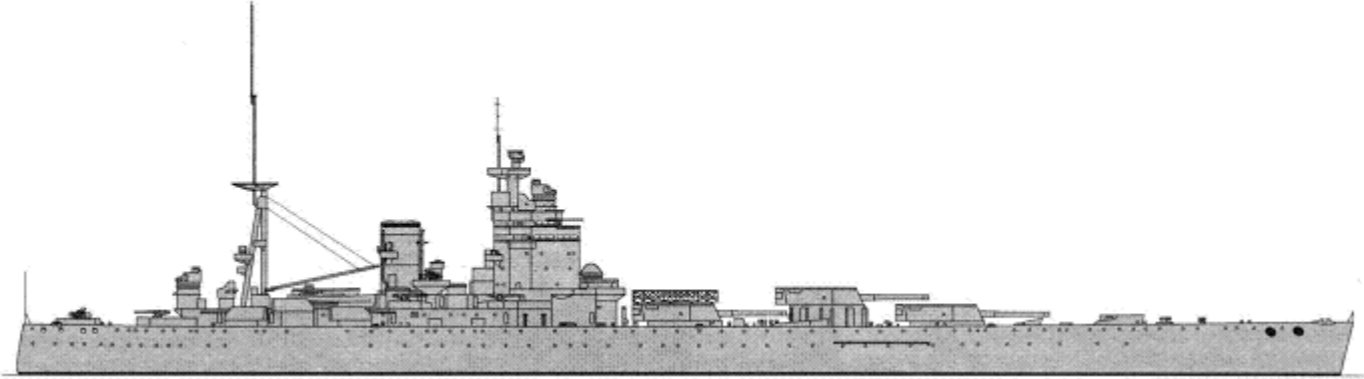
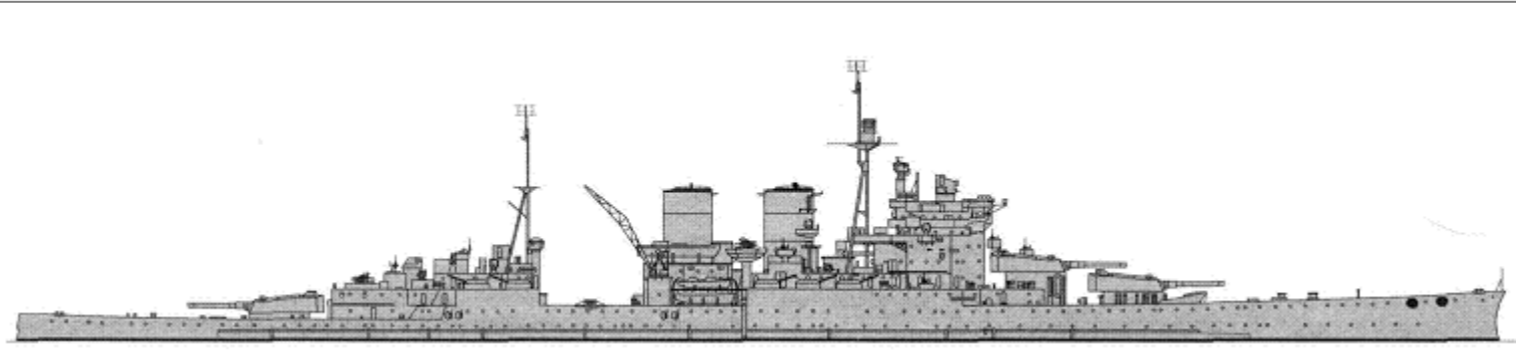
						533TT, 1seaplane(8) (1 Swordfish)
	Nelson	10	Nelson	1927		41250t, 216.4x32.3x10.2m, 8b, 2gt, 45000hp, 23kts, 1314p; 356mm belt, 406mm turrets, 159mm deck, 356mm CT; 3x3-406/45, 6x2-152/50, 6x1-120/40, 2x8-40/39(10), 3x8-40/39(11), 2x4-12.7/62, 2-622TT, 1seaplane(11) (1 Swordfish); radar: type79Y(11)
		11	Rodney	1927		
BC	Renown	1	Renown	1916		36080(1)-38300(2)t, 242.2(1)-242.0(2)x31.2x9.3(1)-9.8(2)m, 8b(1), 42b(2), 4gt(1), 4t(2), 120000(1)-112000(2)hp, 30.7(1)-28.3(2)kts, 1250p; 229mm belt, 229mm turrets, 127(1)-146(2)mm deck, 76(1)-254(2)mm CT; 3x2-381/42, 10x2-114/45(1), (4x3+2x2+4x1)-102/45(2), 3x8-40/39(1), 2x8-40/39(2), 4x4-12.7/62(2), 4x2-533TT(1), 8-533TT(2), 2seaplanes (2 Swordfish)
		2	Repulse	1916		
	Hood	1	3	Hood		
MON	Marshal Ney	1	1	Marshal Sout	1915	6900t, 108.4x27.5x3.2m, 2diesels, 1500hp, 6kts, 187p; 102mm belt, 330mm turret, 102mm deck, 152mm CT; 1x2-381/42, 8x1-102/45, 2x1-76/50, 1x1-76/45, 1x1-47/50, 2x1-40/39
		2	Erebus	1916	8450t, 123.4x26.9x3.6m, 4b, 2vte,	

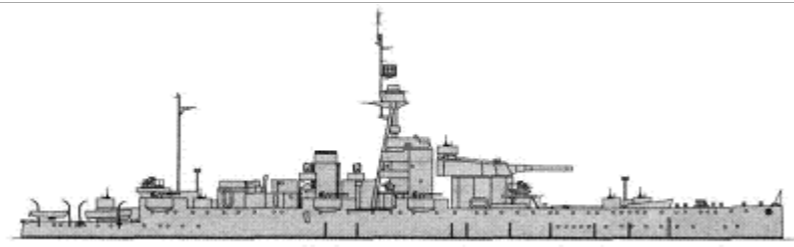

	Erebus	2	3	Terror	1916		6000hp, 12kts, 204p; 102mm belt, 330mm turret, 102mm deck; 1x2-381/42, 8x1-102/45, 2x1-76/45, 2x1-76/40, 2x1-40/39, 1 seaplane (3) (1 Walrus)
--	--------	---	---	--------	------	---	---



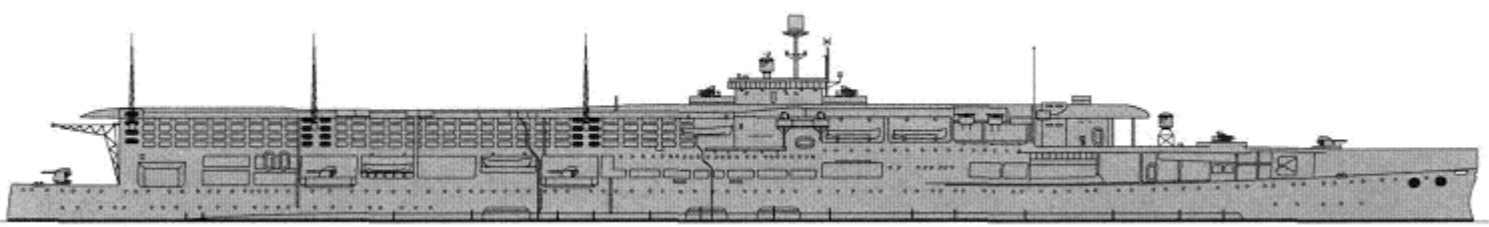
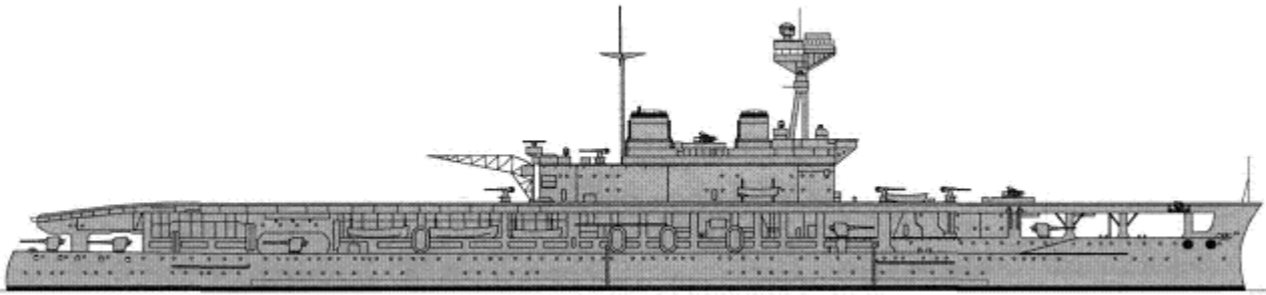
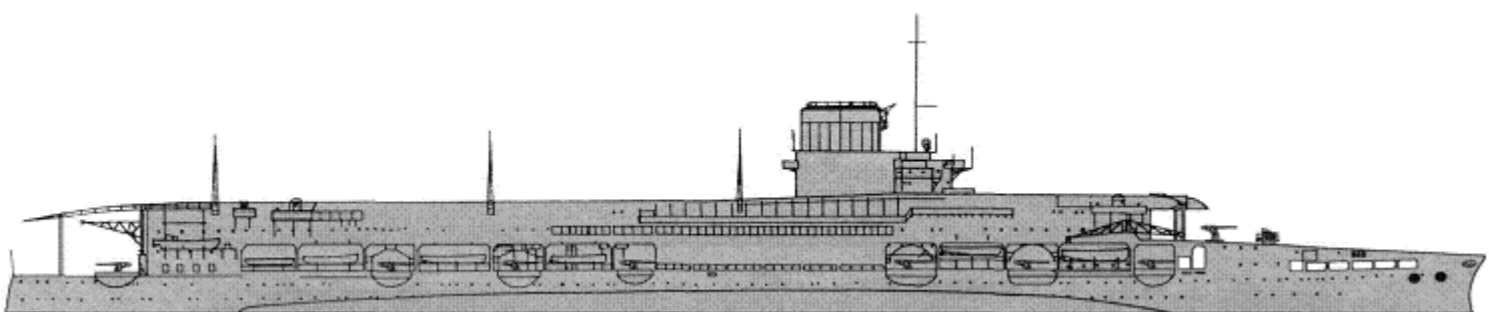
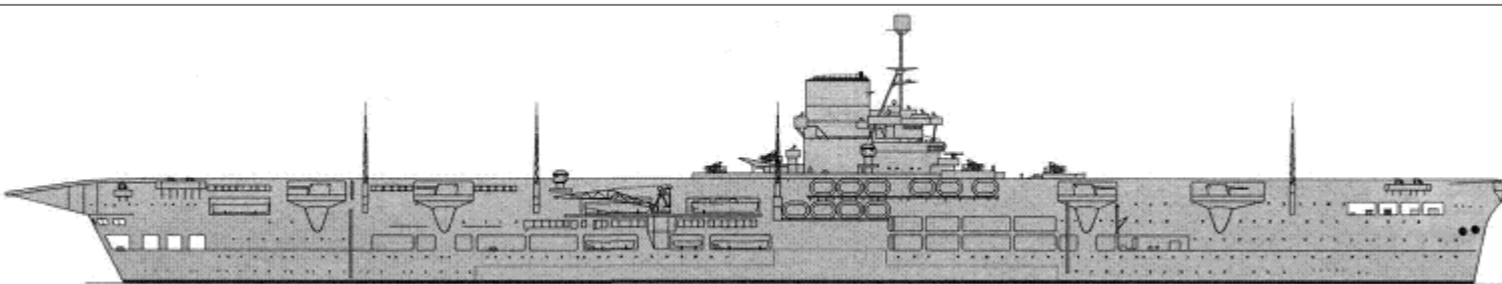
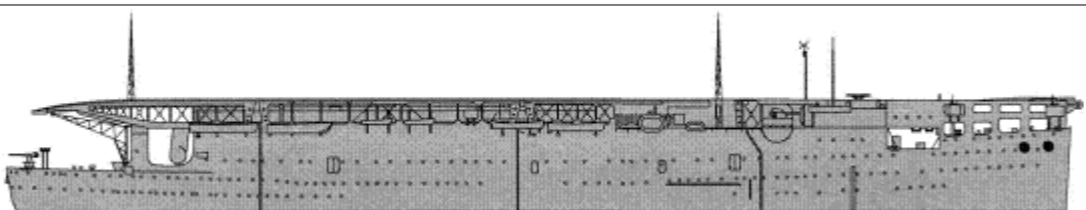

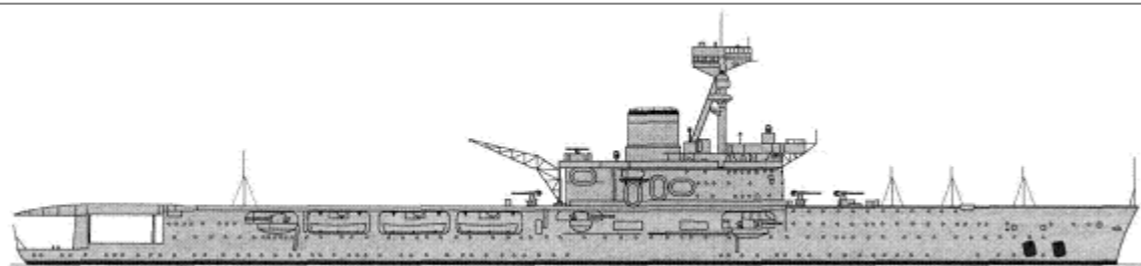
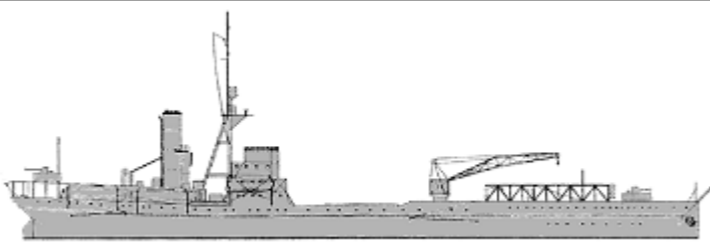
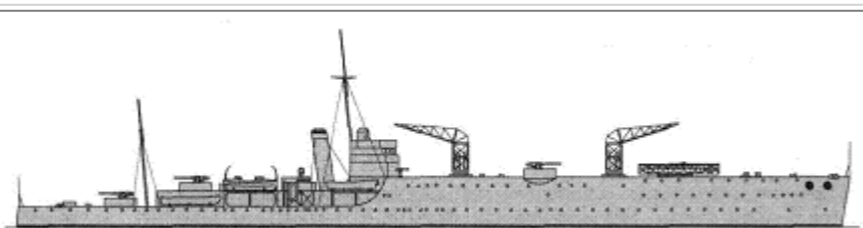
AIRCRAFT CARRYING SHIPS

CV	Furious	1	1	Furious	1917		27165t, 239.7x27.9x8.6m, 18b, 4gt, 90000hp, 30kts, 1218p; 76mm belt, 76mm deck; 6x2-102/45, 3x8-40/39, 2x4-12.7/62, 36aircraft (9 Skua, 18 Swordfish)
	Eagle	1	2	Eagle	1923		26800t, 203.5x32.0x8.1m, 32b, 4gt, 50000hp, 22.5kts, 950p; 114mm belt, 76mm shields, 38mm deck; 9x1-152/50, 4x1-102/45, 2x8-40/39, 2x4-12.7/62, 25aircraft (18 Swordfish)
	Courageous	1	3	Glorious	1917		27400t, 239.8x27.9x8.5m, 18b, 4gt, 90000hp, 1216p; 76mm belt, 76mm deck; 16x1-120/40, 3x8-40/39, 2x4-12.7/62, 48 aircraft (9 Sea Gladiator, 36 Swordfish)
	Ark Royal	1	4	Ark Royal	1938		27720t, 243.8x29.0x8.5m, 6b, 3gt, 102000hp, 31kts, 1580p; 114mm belt, 89mm deck; 8x2-114/45, 4x8-40/39, 8x4-12.7/62, 60aircraft (12 Skua, 6 Roc, 30 Swordfish)
	Argus	1	1	Argus	1918		15750t, 172.5x24.2x6.4m, 8b, 4gt, 20000hp, 20kts, 401p; 51mm magazines; 6x1-102/45, 20aircraft (4 Sea Gladiator, 4 Swordfish)

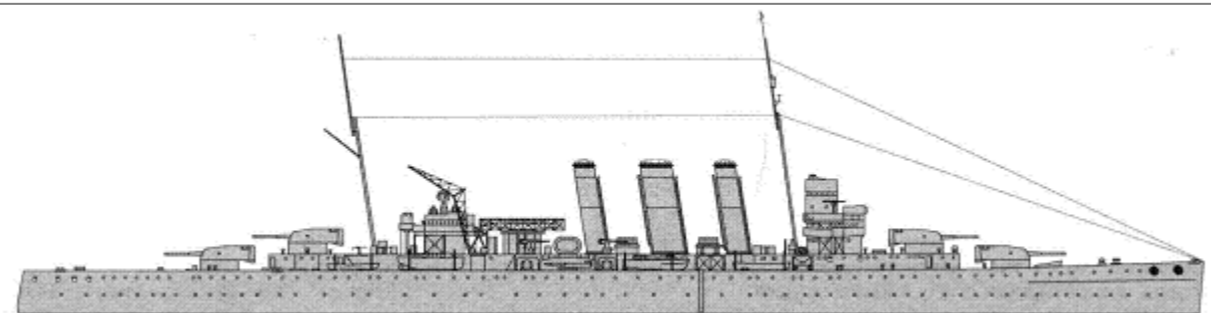
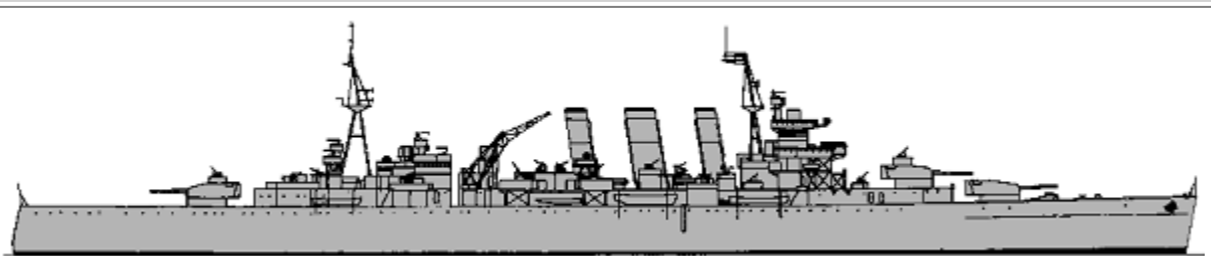
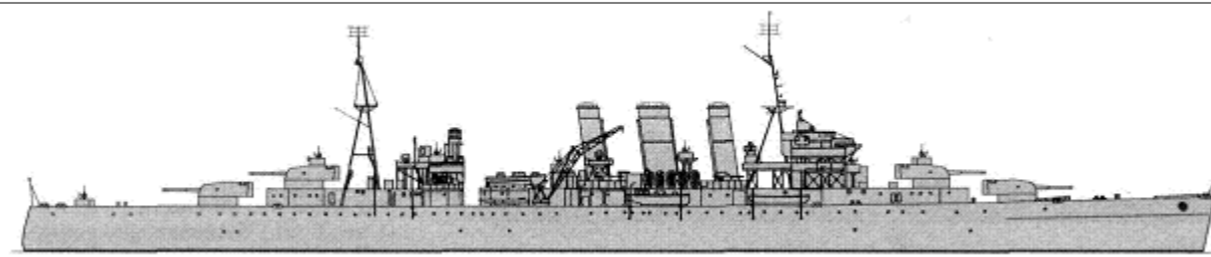
CVL	Hermes	1	2	Hermes	1924		13700t, 182.3x21.4x5.7m, 6b, 2gt, 40000hp, 25kts, 664p; 76mm belt, 25mm deck; 6x1-140/50, 2x1-102/45, 2x4-12.7/62, 20aircraft (12 Swordfish)
	Ark Royal	1	1	Pegasus	1914		7400t, 111.6x15.5x5.5m, 2b, 1vte., 3000hp, 11kts, 180p; 4x1-76/50, 7aircraft (really none)
	Albatross	1	2	Albatross	1929		6350t, 135.3x23.7x5.3m, 4b, 2gt, 12000hp, 21kts, 450p; 4x1-120/40, 4x1-47/40, 4x1-40/39, 9seaplanes (9 Walrus)

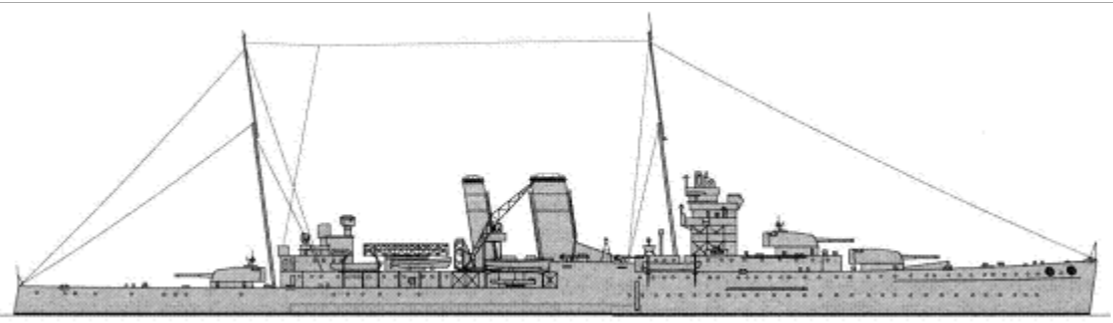
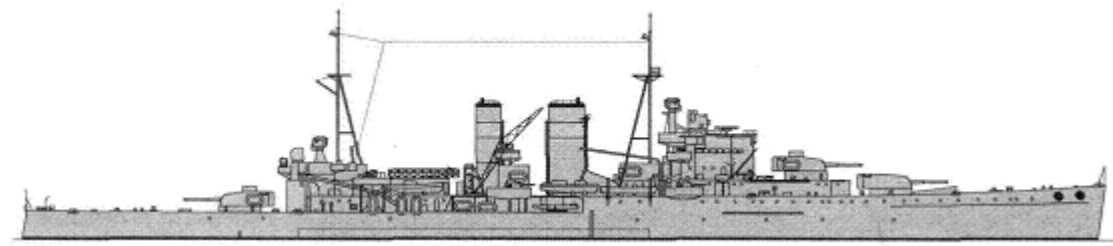
CRUISERS

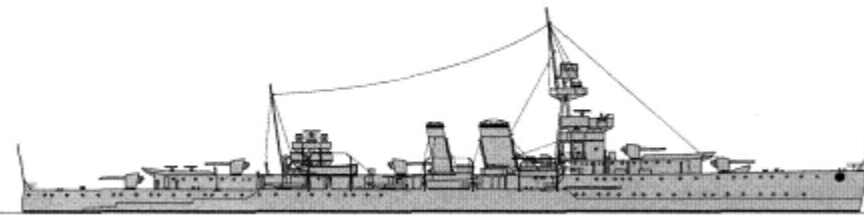
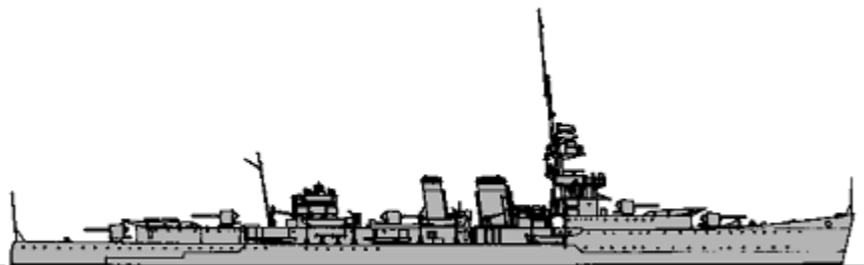
Kent	7	1	Cumberland	1928		13400-13540t, 192.0-192.9x20.8x6.3m, 8b, 4gt, 80000hp, 31.5kts, 710p; 114mm belt, 111mm magazines, 38mm deck, 25mm turrets; 4x2-203/50, 4x2-102/45(1-3, 5), 3x2-102/45(4), 2x4-40/39(1, 4), 2x8-40/39(2, 3, 5), 2x4-12.7/62, 2x4-533TT(5), 2seaplanes(1-4) (1 Walrus(1, 3); 2 Walrus(2, 4)), 1seaplane(5) (1 Walrus)	
		2	Berwick	1928			
		3	Cornwall	1928			
		4	Suffolk	1928			
		5	Kent	1928			
	London	4	6	London	1929		13315t, 192.0-192.9x20.1x6.3m, 8b, 4gt, 80000hp, 32.3kts, 700p; 25mm belt, 102mm magazines, 25mm turrets, 38mm deck; 4x2-203/50, 8x1-102/45, 2x4-12.7/62(7-9), 2x4-533TT, 1seaplane (1 Walrus (7-9))
			7	Devonshire	1929		
8			Sussex	1929			
9	Shropshire		1929				
CA Norfolk	2	10	Dorsetshire	1930		13425t, 192.9-193.7x20.1x6.4m, 8b, 4gt, 80000hp, 32.3kts, 710p; 25mm belt, 102mm magazines, 38mm deck, 25mm turrets; 4x2-203/50, 4x2-102/45, 2x8-40/39, 2x4-12.7/62, 2x4-533TT, 1seaplane (1 Walrus)	
		11	Norfolk	1930			

York	1	12	York	1930		10350t, 175.3x17.4x6.2m, 8b, 4gt, 80000hp, 32.3kts, 623p; 76mm belt, 102mm magazines, 38mm deck, 25mm turrets; 3x2-203/50, 4x1-102/45, 2x4-12.7/62, 2x3-533TT, 1seaplane (1 Walrus)
Exeter	1	13	Exeter	1931		10490t, 175.3x17.7x6.2m, 8b, 4gt, 80000hp, 32kts, 630p; 76mm belt, 127mm magazines, 38mm deck, 25mm turrets; 3x2-203/50, 4x1-102/45, 2x4-12.7/62, 2x3-533TT, 2seaplanes (2 Walrus)
Caledon	3	1	Caledon	1917		4950t, 137.2x13.0x5.0m, 6b, 2gt, 40000hp, 29kts, 400p; 76mm belt, 25mm shields, 25mm deck; 5x1-152/45, 2x1-76/45, 4x1-47/40, 2x1-40/39, 4x2-533TT
		2	Calypso	1917		
		3	Caradoc	1917		
Ceres	5	4	Cardiff	1917		5020(4, 5, 8)-5355(6)-5468(7)t, 137.2x13.3x4.5m, 6b, 2gt, 40000hp, 29kts, 460p; 76mm belt, 25(4, 5, 8)mm shields, 25mm deck; 5x1-152/45(4, 5, 8), 10x1-102/45(6, 7), 2x1-76/45(4, 5, 6), 1x8-40/39(6, 7), 2x1-40/39(4, 5, 8), 2x4-12.7/62(6, 7), 4x2-533TT(4, 5, 8)
		5	Ceres	1917		
		6	Curlew	1917		
		7	Coventry	1918		
		8	Curacoa	1918		
Carlisle	5	9	Carlisle	1918		5250(9, 12, 13)-5215(10, 11)t, 137.6x13.3x4.7m, 6b, 2gt, 40000hp, 29kts, 432p; 76mm belt, 25(9, 12, 13)mm shields, 25mm deck; 5x1-152/45(9, 12, 13), 4x2-102/45(10, 11), 2x1-76/45(9, 12, 13), 2x1-40/39(9, 12, 13), 1x4-40/39(10, 11), 2x4-12.7/62(10, 11), 4x2-533TT(9, 12, 13)
		10	Cairo	1919		
		11	Calcutta	1919		
		12	Colombo	1919		
		13	Capetown	1922		
Danae	3	14	Danae	1918		5870t, 143.6x13.9x5.0m, 6b, 2gt, 40000hp, 29kts, 450p; 76mm belt, 25mm shields, 25mm deck, 76mm CT; 6x1-152/45, 3x1-102/45, 4x1-40/39(14), 2x1-40/39(15, 16), 4x3-533TT
		15	Dauntless	1918		
		16	Dragon	1918		
		17	Delhi	1919		

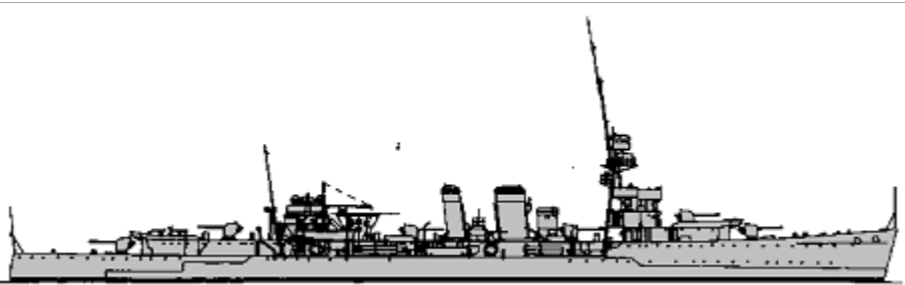
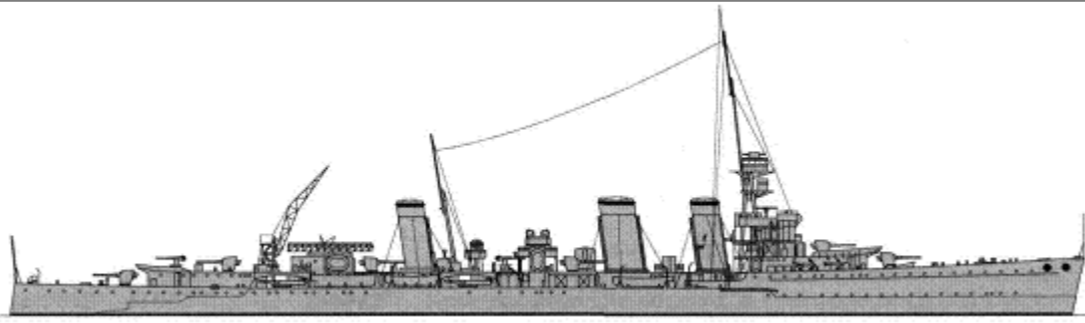
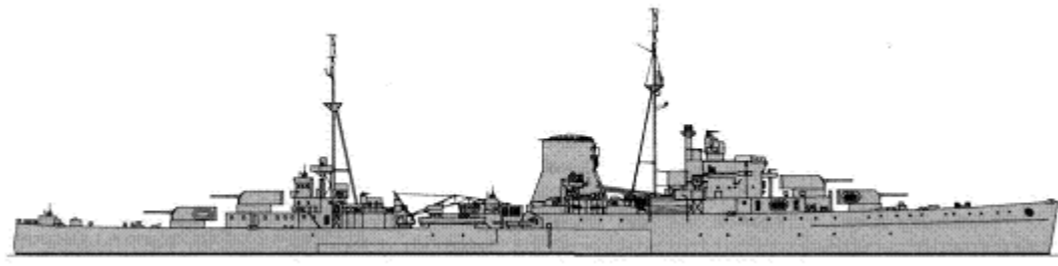
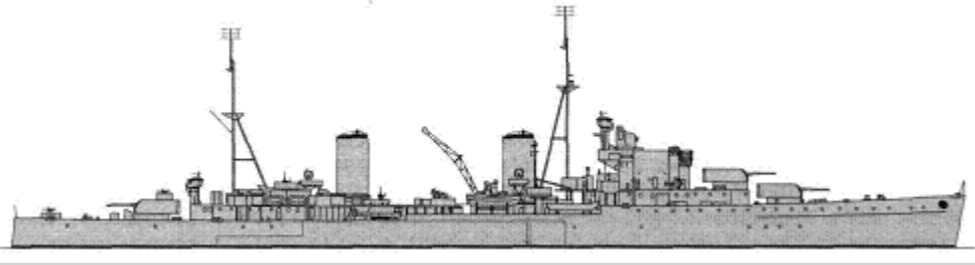
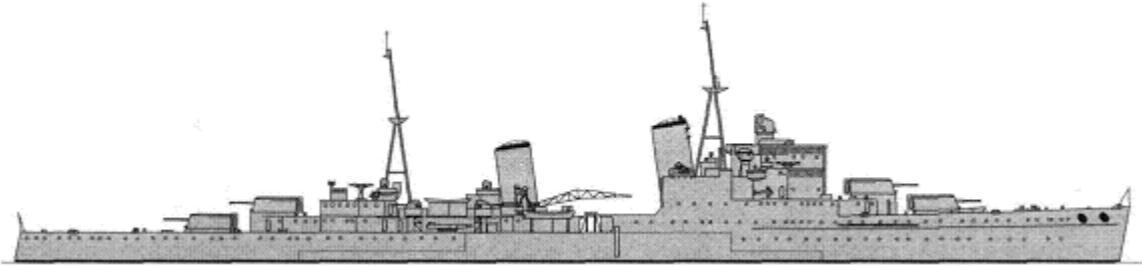

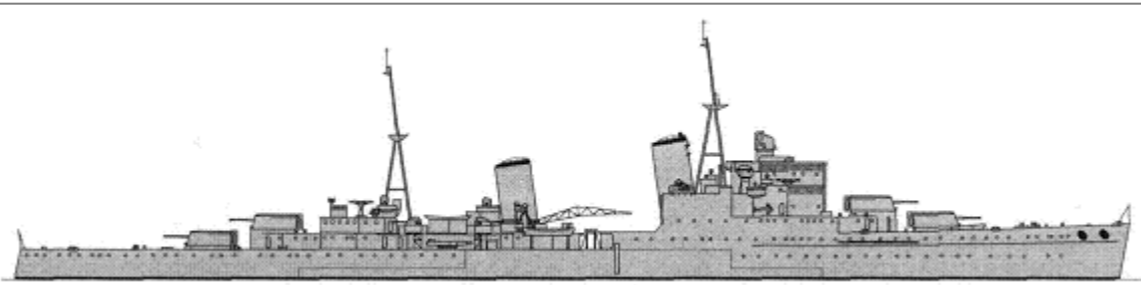
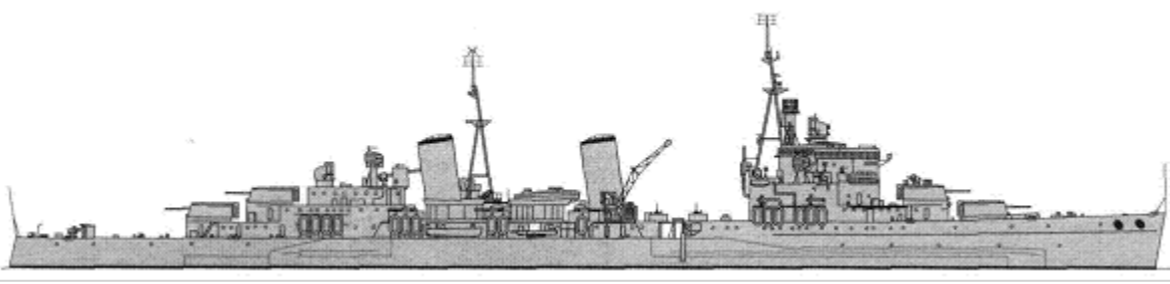

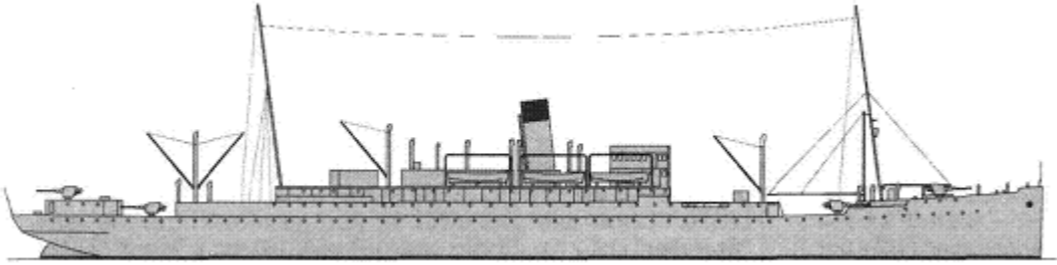

CL	Delhi	5	18	Dunedin	1919		5870t, 143.6x13.9x5.0m, 6b, 2gt, 40000hp, 29kts, 450p; 76mm belt, 25mm shields, 25mm deck, 76mm CT; 6x1-152/45, 3x1-102/45, 2x1-40/39(17, 19, 21), 2x4-12.7/62(18, 20), 4x3-533TT
			19	Durban	1921		
			20	Despatch	1922		
			21	Diomede	1922		
			Hawkins	1	22		
	Emerald	2	23	Emerald	1926		9450t, 173.7x16.6x5.6m, 8b, 4gt, 80000hp, 33kts, 450p; 76mm belt, 25mm turret/shields, 25mm deck, 76mm CT; 7x1-152/45(23), (1x2+5x1)-152/45(24), 3x1-102/45, 2x1-40/39, 4x4-12.7/62(23), 4x4-533TT, 1seaplane (1 Seafox)
			24	Enterprise	1926		
	Leander	5	25	Leander	1933		9000-9280t, 169.0x16.8(25)-17.0(26-29)x5.8-6.0m, 6b, 4gt, 72000hp, 32.5kts, 570p; 76mm belt, 89mm magazines, 25mm turrets, 51mm deck; 4x2-152/50, 4x2-102/45(25, 27-29), 4x1-102/45(26), 3x4-12.7/62, 2x4-533TT, 2seaplanes (1 Walrus(25, 26); 2 Seafox(27-29))
			26	Achilles	1933		
			27	Neptune	1934		
			28	Orion	1934		
			29	Ajax	1935		
	Arethusa	4	30	Arethusa	1935		6665-6715t, 154.2x15.5x5.0m, 4b, 4gt, 64000hp, 32.3kts, 500p; 57mm belt, 76mm magazines, 25mm turrets, 25mm deck; 3x2-152/50, 4x1-102/45(30), 4x2-102/45(31-33), 2x4-12.7/62, 2x3-533TT, 1seaplane(30-32) (2 Seafox(30, 31), 1 Seafox(32))
			31	Galatea	1935		
			32	Penelope	1936		
			33	Aurora	1937		
	Southampton	5	34	Birmingham	1937		11350t, 180.3x18.8x6.2m, 4b, 4gt, 75000hp, 32kts, 748p; 114mm belt, 25mm turrets, 38mm deck; 4x3-152/50, 4x2-102/45, 2x4-40/39, 2x4-12.7/62, 2x3-533TT, 3seaplanes(1 Walrus(34), 2 Walrus(35-38)); radar: type79Y(37)
			35	Glasgow	1937		
			36	Newcastle	1937		
			37	Sheffield	1937		
			38	Southampton	1937		

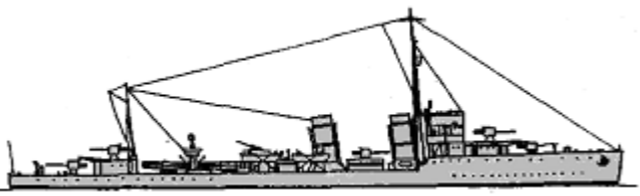

	Gloucester	3	39	Liverpool	1938		11650t, 180.3x19.0x6.3m, 4b, 4gt, 82500hp, 32.3kts, 748p; 114mm belt, 102mm turrets, 51mm deck; 4x3-152/50, 4x2-102/45, 2x4-40/39, 2x4-12.7/62, 2x3-533TT, 3seaplanes (2 Walrus)			
			40	Manchester	1938					
			41	Gloucester	1939					
	Edinburgh	2	42	Belfast	1939				13175t, 187.0x19.3x6.5m, 4b, 4gt, 80000hp, 32.5kts, 850p; 114mm belt, 102mm turrets, 76mm deck; 4x3-152/50, 6x2-102/45, 2x8-40/39, 2x4-12.7/62, 2x3-533TT, 3seaplanes (2 Walrus)	
			43	Edinburgh	1939					
	CM	Adventure	1	1	Adventure					1927
			1	Alaunia	1925	14030brt, 158.4x19.9xm, 2gt, 15kts; 8x1-152/45, 2x1-76/45				
			2	Alcantara	1926	22209brt, 192.2x23.9xm, 2d, 19kts; 8x1-152/45, 2x1-76/45				
			3	Andania	1921	13950brt, 158.6x19.9xm, 2gt, 15kts; 8x1-152/45, 2x1-76/45				
			4	Arawa	1921	14462brt, 161.8x20.8xm, 2gt, 15kts; 7x1-152/45, 2x1-76/45				
			5	Ascania	1923	14013brt, 158.5x19.9xm, 2gt, 15kts; 8x1-152/45, 2x1-76/45				
			6	Asturias	1925	22048brt, 192.2x23.9xm, 2d, 19kts; 8x1-152/45, 2x1-76/45				
			7	Aurania	1924	13984brt, 158.4x19.9xm, 2gt, 15kts; 8x1-152/45, 2x1-76/45				
			8	Ausonia	1921	13912brt, 158.5x19.9xm, 2gt, 15kts; 8x1-152/45, 2x1-76/45				
			9	California	1923	16792brt, 168.5x21.5xm, 2gt, 16kts; 8x1-152/45, 2x1-76/45				
			10	Canton	1938	15700brt, 165.1x22.3xm, 2gt, 19kts; 8x1-152/45, 2x1-76/45				
			11	Carinthia	1925	20277brt, 183.1x22.5xm, 2gt, 16kts; 8x1-152/45, 2x1-76/45				
			12	Carnarvon Castle	1926	20063brt, 192.2x22.4xm, 2d, 18kts; 8x1-152/45, 2x1-76/45				
			13	Carthage	1931	14182brt, 159.2x21.8xm, 2gt, 18kts; 8x1-152/45, 2x1-76/45				
			14	Cathay	1924	15225brt, 159.6x21.4xm, 2vqe, 16kts; 8x1-152/45, 2x1-76/45				
			15	Cheshire	1927	10520brt, 147.4x18.4xm, 2d, 15kts; 6x1-152/45, 2x1-76/45				
			16	Chitral	1925	15346brt, 160.1x21.4xm, 2vqe, 16kts; 7x1-152/45, 3x1-102/45				
			17	Cilicia	1937	11137brt, 154.2x20.2xm, 2d, 16.5kts; 8x1-152/45, 2x1-76/45				
			18	Circassia	1937	11137brt, 154.2x20.2xm, 2d, 16.5kts; 8x1-152/45, 2x1-76/45				

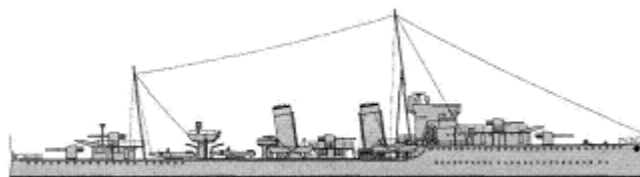
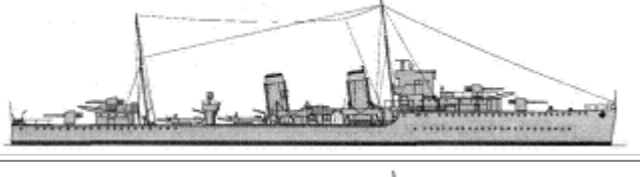
AMC	41	19	Corfu	1931		14170brt, 159.2x21.8xm, 2gt, 17kts; 8x1-152/45, 2x1-76/40
		20	Derbyshire	1935		11650brt, 147.1x20.2xm, 2d, 16kts; 6x1-152/45, 2x1-76/45
		21	Dunnottar Castle	1936		15007brt, 164.6x21.9xm, 2d, 16kts; 7x1-152/45, 2x1-76/45
		22	Dunvegan Castle	1936		15007brt, 164.6x21.9xm, 2d, 16kts; 7x1-152/45, 2x1-76/40
		23	Esperance Bay	1921		14204brt, 161.7x20.8xm, 2gt, 15kts; 7x1-152/45, 2x1-76/45
		24	Forfar	1920		16402brt, 167.2x21.4xm, 2gt, 16kts; 8x1-152/45, 2x1-76/45
		25	Jervis Bay	1922		14164brt, 161.7x20.8xm, 2gt, 15kts; 7x1-152/45, 2x1-76/45
		26	Kanimbla	1935		10985brt, 142.9x20.2x7.4m, 2d, 16.5kts; 7x1-152/45, 2x1-76/45
		27	Laurentic	1927		18724brt, 176.2x23.0xm, 3gt, 16.5kts; 7x1-140/50, 3x1-102/45
		28	Letitia	1924		13475brt, 160.2x20.2xm, 2gt, 15kts; 8x1-152/45, 2x1-76/45
		29	Maloja	1923		20914brt, 183.1x22.4xm, 2vqe, 16kts; 8x1-152/45, 2x1-76/45
		30	Montclare	1921		16314brt, 167.5x21.4xm, 2gt, 17kts; 7x1-140/50, 3x1-102/45
		31	Mooltan	1923		20952brt, 183.1x22.4xm, 2vqe, 17kts; 8x1-152/45, 2x1-76/45
		32	Moreton Bay	1921		14193brt, 161.7x20.8xm, 2gt, 15kts; 7x1-152/45, 2x1-76/45
		33	Pretoria Castle	1938		17160brt, 173.9x23.3xm, 2d, 19.5kts; 8x1-152/45, 2x1-76/40
		34	Queen of Bermuda	1932		22575brt, 168.7x23.3xm, tg, 4em, 20kts; 7x1-152/45, 2x1-76/45
		35	Rajputana	1925		16644brt, 166.9x21.7xm, 2vqe, 17kts; 8x1-152/45, 2x1-76/45
		36	Ranchi	1925		16738brt, 168.2x21.7xm, 2vqe, 18kts; 8x1-152/45, 2x1-76/45
		37	Ranpura	1924		16688brt, 168.2x21.7xm, 2vqe, 17kts; 8x1-152/45, 2x1-76/45
		38	Salopian	1926		10515brt, 147.4x18.4xm, 2d, 15kts; 6x1-152/45, 2x1-76/45
		39	Scotstoun	1925		17046brt, 168.5x21.5xm, 2gt, 16kts; 8x1-152/45, 2x1-76/45
40	Transylvania	1925		16923brt, 168.4x21.4xm, 2gt, 16kts; 8x1-152/45, 2x1-76/45		
41	Worcestershire	1930		11402brt, 147.2x19.6xm, 2d, 15kts; 6x1-152/45, 2x1-76/45		

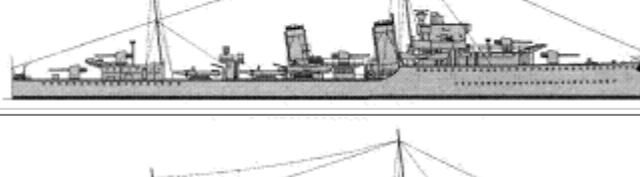
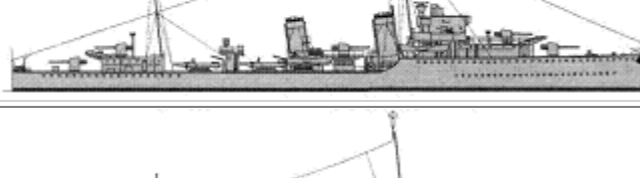
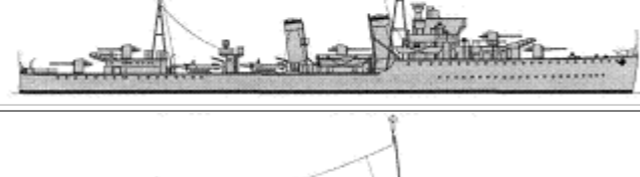

## TORPEDO SHIPS

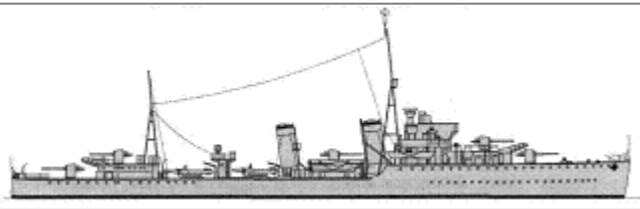
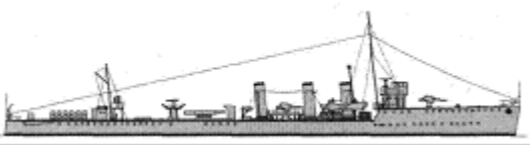
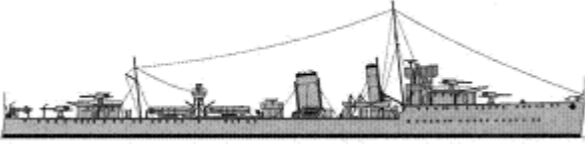
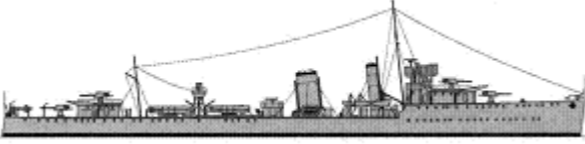
V	2	1	Valentine	1917		1400t, 95.1x9.0x3.2m, 3b, 2gt, 27000hp, 34kts, 115p; 4x1-102/45(1), 2x2-102/45(2), 2x1-40/39(1), 2x4-12.7/62(2), 2x3-533TT(1), 2DCT(2), 1DCR
		2	Valorous	1917		
		3	Wallace	1919		
		4	Keppel	1924		
						2000t, 100.3x9.6x3.8m, 4b, 2gt, 40000hp, 36kts, 183p; 5x1-120/45(4, 5), 2x2-102/45(3), 1x1-76/45(4, 5), 1x4-

DL	Shakespeare	3	5	Broke	1925		40/39(3), 2x4-12.7/62(3), 2x3-533TT(4, 5), 2DCT, 1DCR
	Scott	5	6	Douglas	1918		2050t, 101.3x9.7x3.8m, 4b, 2gt, 40000hp, 36kts, 164p; 5x1-120/45, 1x1-76/45, 2x3-533TT, 2DCT, 1DCR
			7	Campbell	1918		
			8	Montrose	1918		
			9	Malcolm	1919		
			10	Mackay	1919		
	A-leader	1	11	Codrington	1930		2012t, 104.5x10.3x3.8m, 3b, 2gt, 39000hp, 35kts, 185p; 5x1-120/45, 2x1-40/39, 2x4-533TT, 3DCR
	B-leader	1	12	Keith	1931		1821t, 98.5x9.8x3.7m, 3b, 2gt, 34000hp, 35.2kts, 138p; 4x1-120/45, 2x1-40/39, 2x4-533TT, 2DCT, 1DCR
	D-leader	1	13	Duncan	1933		1942t, 100.3x10.1x3.8m, 3b, 2gt, 36000hp, 36kts, 175p; 4x1-120/45, 2x1-40/39, 2x4-533TT, 2DCT, 1DCR
	E-leader	1	14	Exmouth	1934		2009-2049t, 104.5x10.3x3.8m, 3b, 2gt, 38000hp, 36.7kts, 175p; 5x1-120/45, 2x4-12.7/62, 2x4-533TT, 2DCT, 1DCR
F-leader	1	15	Faulknor	1935		2009-2049t, 104.5x10.3x3.8m, 3b, 2gt, 38000hp, 36.7kts, 175p; 5x1-120/45, 2x4-12.7/62, 2x4-533TT, 2DCT, 1DCR	
E-leader	1	16	Grenville	1936		2033t, 100.6x10.5x3.9m, 3b, 2gt, 38000hp, 36.5kts, 178p; 5x1-120/45, 2x4-12.7/62, 2x4-533TT, 2DCT, 1DCR	
F-leader	1	17	Hardy	1936		2053t, 102.7x10.4x3.9m, 3b, 2gt, 38000hp, 36.5kts, 178p; 5x1-120/45, 2x4-12.7/62, 2x4-533TT, 2DCT, 1DCR	

G-leader	1	18	Inglefield	1937		2081t, 102.7x10.4x3.9m, 3b, 2gt, 38000hp, 36.5kts, 178p; 5x1-120/45, 2x4-12.7/62, 2x5-533TT, 2DCT, 1DCR
R-Admiralty	1	1	Skate	1917		1244t, 84.1x8.1x2.7m, 3b, 2gt, 27000hp, 36kts, 82p; 2x1-102/40, 1x1-40/39, 1x2-533TT, 40mines
V-Admiralty	16	2-17	Vanquisher Vanoc Vega Venetia Verdun Vimiera Vivacious Vimy Vanessa Vanity Velox Versatile Vesper Vidette Vivien Vortigern	1917 1917 1917 1917 1917 1917 1917 1918 1918 1918 1918 1918 1918 1918 1918 1918		1480-1523t, 95.1x9.0x3.2m, 3b, 2gt, 27000hp, 34kts, 134p; 4x1-102/45(2, 3, 5-15, 17) (can be 3x1-102/45 on 2, 3, 7, 12, 13, 17), 2x2-102/45(4, 16), 1x1-40/39(2, 3, 5-15, 17), 2x4-12.7/62(4, 16), 2x3-533TT(5, 6, 10-11, 14, 15), (1x3+1x2)-533TT(2, 3, 7, 12, 13, 17) (can be 1x2-533TT on 2, 3, 7, 12, 13, 17), 2DCT (or can be not on 2, 3, 7, 12, 13, 17), 1DCR, MS(2, 3, 5-15, 17), (can be 60mines on 2, 3, 7, 12, 13, 17)
V-Thornycroft	2	18-19	Viceroy Viscount	1918 1918		1512t, 95.1x9.4x2.9m, 3b, 2gt, 27000hp, 34kts, 134p; 4x1-102/45, 1x1-40/39, 2x3-533TT, 2DCT, 1DCR, MS
W-Admiralty	16	20-31	Wakeful Watchman Walpole Whitley Walker Westcott Wolfhound Warwick Wessex Whirlwind Wrestler Winchelsea	1917 1918 1918 1918 1918 1918 1918 1918 1918 1918 1918 1918		1490t, 95.1x9.0x3.2m, 3b, 2gt, 27000hp, 34kts, 134p; 4x1-102/45(20-22, 24-35) (can be 3x1-102/45 on 21, 24, 27, 29), 2x2-102/45(23), 1x1-40/39(20-22, 24-35), 2x4-12.7/62(23), 2x3-533TT(20-22, 24-35) (can be 1x3-533TT on 21, 24, 27, 29), 2DCT, 1DCR, MS(20-22, 24-35), (can be 60mines on 21, 24, 27, 29)

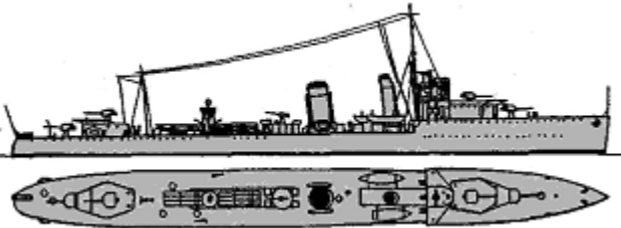
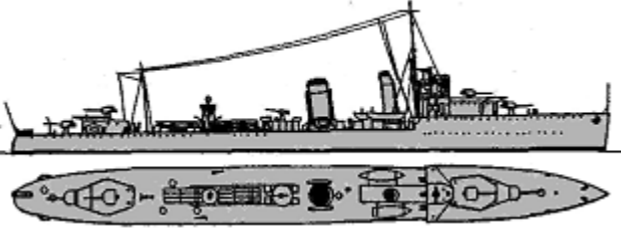

		32	Winchester	1918		
		33	Westminster	1918		
		34	Windsor	1918		
		35	Wryneck	1918		
W-Thornycroft	2	36	Woolsey	1918		1512t, 95.1x9.4x2.9m, 3b, 2gt, 27000hp, 34kts, 134p; 2x2-102/45, 2x4-12.7/62, 2DCT, 1DCR
		37	Woolston	1918		
S-Admiralty	11	38	Scimitar	1918		1225t, 84.1x8.1x2.7m, 3b, 2gt, 27000hp, 36kts, 90p; 3x1-102/40(38-42, 45, 46, 48), 2x1-102/40(43, 44, 47), 1x1-40/39, 2x2-533TT(38-42, 45, 46, 48), 2DCT, 1DCR, 40mines(43, 44, 47), MgS(38)
		39	Scout	1918		
		40	Sabre	1918		
		41	Saladin	1919		
		42	Sardonyx	1919		
		43	Stronghold	1919		
		44	Sturdy	1919		
		45	Tenedos	1919		
		46	Thanet	1919		
		47	Thracian	1922		
		48	Shikari	1924		
Modified W-Admiralty	14	49	Vansittart	1919		1508t, 95.1x9.0x3.2m, 3b, 2gt, 27000hp, 34kts, 127p; 4x1-120/45, 2x1-40/39, 2x3-533TT, 2DCT, 1DCR
		50	Volunteer	1919		
		51	Venomous	1919		
		52	Verity	1919		
		53	Wanderer	1919		
		54	Veteran	1919		
		55	Whitshed	1919		
		56	Wild Swan	1919		
		57	Witherington	1919		
		58	Wivern	1919		
		59	Wolverine	1920		
		60	Worcester	1922		
		61	Wren	1923		
		62	Whitehall	1924		
Modified W-Thornycroft	2	63	Wishart	1920		1530t, 95.1x9.4x2.9m, 3b, 2gt, 30000hp, 35kts, 127p; 4x1-120/45, 2x1-40/39, 2x3-533TT, 2DCT, 1DCR
		64	Witch	1924		
						1862t, 98.5x9.6x3.8m, 3b, 2gt, 39500hp, 37kts, 138p; 4x1-120/45, 1x1-76/45, 2x1-40/39, 1x3-533TT, 2DCT,

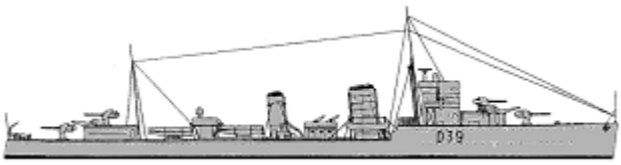
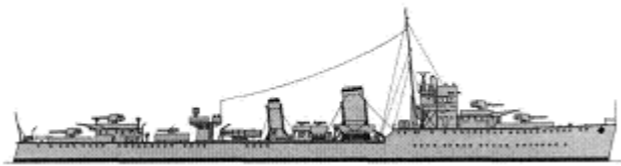
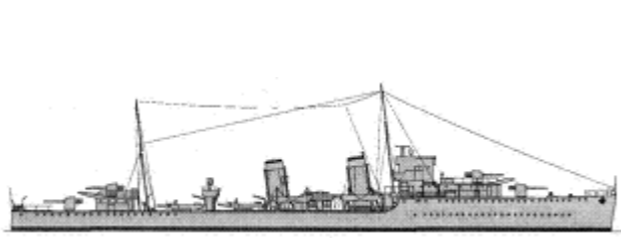
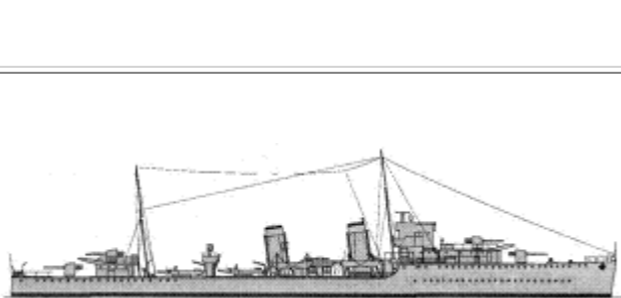
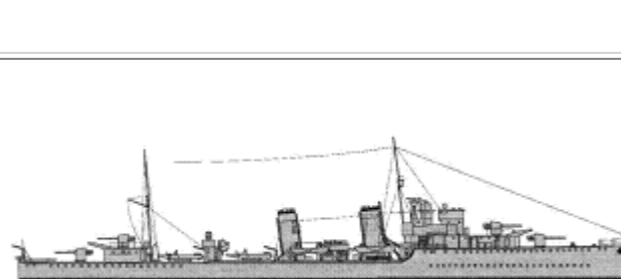
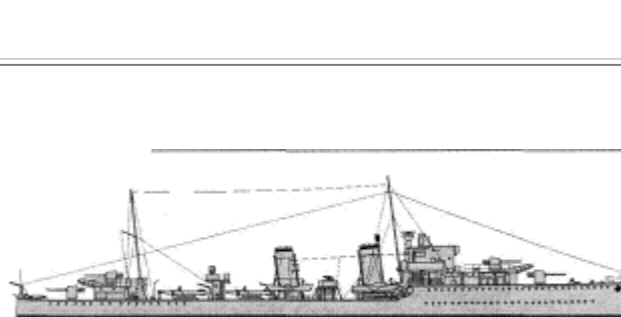

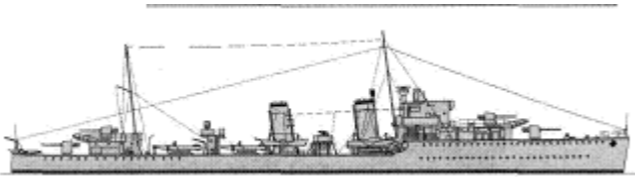
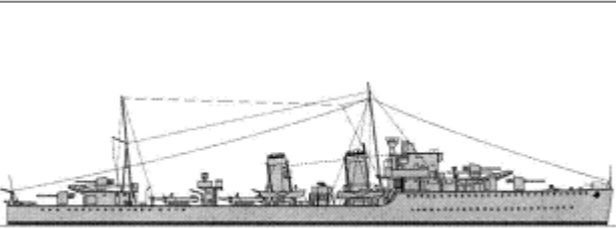
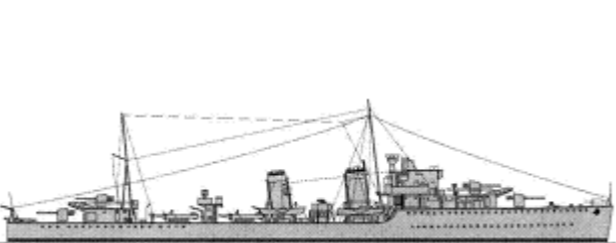
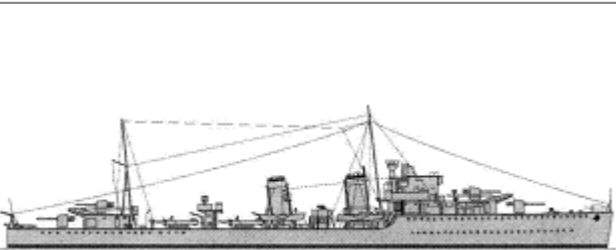
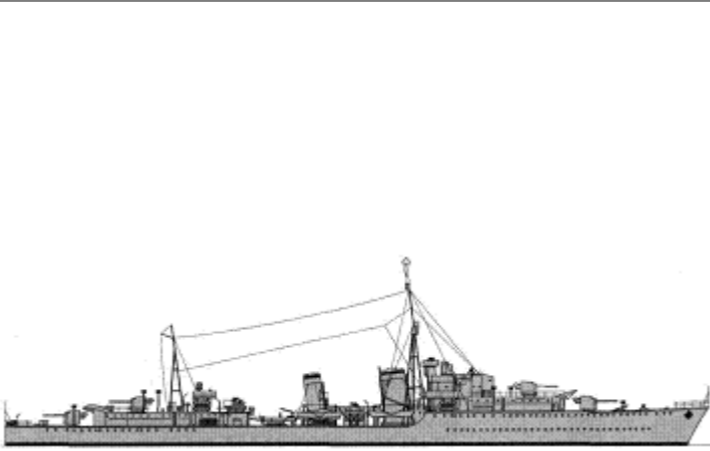

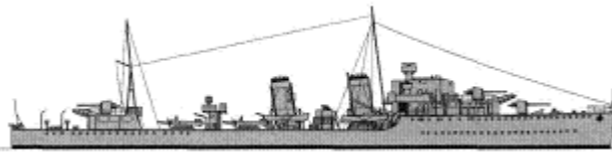
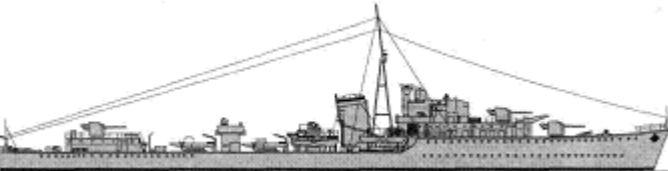
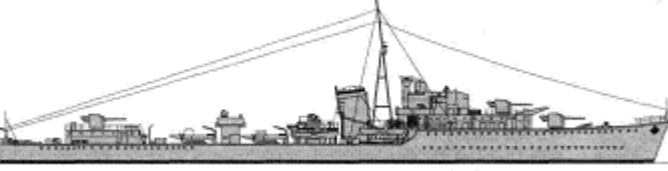
			Amazon	1926		1DCR	
			Ambuscade	1927		1585t, 98.1x9.5x3.5m, 3b, 2gt, 33000hp, 37kts, 138p; 4x1-120/45, 2x1-40/39, 2x3-533TT	
DD	A	8	67	Acasta	1930		1747-1815t, 98.5x9.8x3.7m, 3b, 2gt, 34000hp, 35.2kts, 138p; 4x1-120/45, 2x1-40/39, 2x4-533TT, 3DCR, MS
			68	Achates	1930		
			69	Active	1930		
			70	Antelope	1930		
			71	Anthony	1930		
			72	Ardent	1930		
			73	Arrow	1930		
			74	Acheron	1931		
B		7	75	Basilisk	1931		1747-1815t, 98.5x9.8x3.7m, 3b, 2gt, 34000hp, 35.2kts, 138p; 4x1-120/45, 2x1-40/39, 2x4-533TT, 2DCT, 1DCR
			76	Beagle	1931		
			77	Boadicea	1931		
			78	Boreas	1931		
			79	Brazen	1931		
			80	Brilliant	1931		
			81	Bulldog	1931		
D		7	82	Daring	1932		1865-1942t, 100.3x10.1x3.8m, 3b, 2gt, 36000hp, 36kts, 145p; 4x1-120/45, 2x1-40/39(82-95), 2x4-12.7/62(86-88), 2x4-533TT, 2DCT, 1DCR
			83	Defender	1932		
			84	Diamond	1932		
			85	Diana	1932		
			86	Dainty	1933		
			87	Decoy	1933		
			88	Delight	1933		
E		8	89	Echo	1934		1886-1940t, 100.3x10.1x3.8m, 3b, 2gt, 36000hp, 36kts, 145p; 4x1-120/45(89-94), 2x1-120/45(95, 96), 2x4-12.7/62, 2x4-533TT, 2DCT(89-94), 1DCR(89-94), MS(89-94), 72mines(95, 96)
			90	Eclipse	1934		
			91	Electra	1934		
			92	Encounter	1934		
			93	Escapade	1934		
			94	Escort	1934		
			95	Esk	1934		
			96	Express	1934		
			97	Fearless	1934		
			98	Fame	1935		

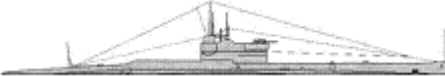

F	8	99	Firedrake	1935		1886-1940t, 100.3x10.1x3.8m, 3b, 2gt, 36000hp, 36kts, 145p; 4x1-120/45, 2x4-12.7/62, 2x4-533TT, 2DCT, 1DCR, MS
		100	Forester	1935		
		101	Foresight	1935		
		102	Fortune	1935		
		103	Foxhound	1935		
		104	Fury	1935		
G	7	105	Gallant	1936		1854-1890t, 98.5x10.1x3.8m, 3b, 2gt, 34000hp, 36kts, 145p; 4x1-120/45, 2x4-12.7/62, 2x4-533TT(105, 106, 108-111), 2x5-533TT(107), 2DCT, 1DCR, MS
		106	Garland	1936		
		107	Glowworm	1936		
		108	Grafton	1936		
		109	Grenade	1936		
		110	Greyhound	1936		
		111	Griffin	1936		
H	8	112	Hasty	1936		1854-1890t, 98.5x10.1x3.8m, 3b, 2gt, 34000hp, 36kts, 145p; 4x1-120/45, 2x4-12.7/62, 2x4-533TT, 2DCT, 1DCR, MS
		113	Hereward	1936		
		114	Hero	1936		
		115	Hostile	1936		
		116	Hotspur	1936		
		117	Hunter	1936		
		118	Hyperion	1936		
		119	Havock	1937		
I	8	120	Icarus	1937		1854-1890t, 98.5x10.1x3.8m, 3b, 2gt, 34000hp, 36kts, 145p; 4x1-120/45, 2x4-12.7/62, 2x5-533TT, 2DCT, 1DCR, MS
		121	Ilex	1937		
		122	Imogen	1937		
		123	Imperial	1937		
		124	Intrepid	1937		
		125	Isis	1937		
		126	Ivanhoe	1937		
		127	Impulsive	1938		
Tribal	16	128	Afridi	1938		2519t, 114.9x11.1x4.0m, 3b, 2gt, 44000hp, 36.2-36.5kts, 190p; 4x2-120/45, 1x4-40/39, 2x4-12.7/62, 1x4-533TT, 2DCT, 1DCR
		129	Ashanti	1938		
		130	Cossack	1938		
		131	Eskimo	1938		
		132	Gurkha	1938		
		133	Mohawk	1938		
		134	Nubian	1938		
		135	Sikh	1938		
		136	Somali	1938		
		137	Zulu	1938		
		138	Bedouin	1939		

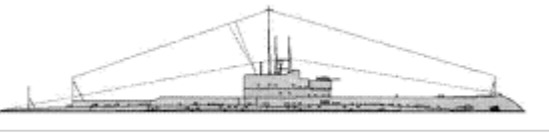
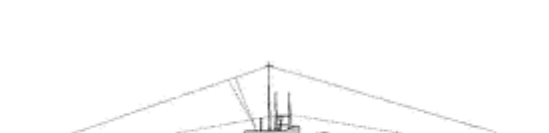
		139	Maori	1939		
		140	Mashona	1939		
		141	Matabele	1939		
		142	Punjabi	1939		
		143	Tartar	1939		
H-Brazilian	1	144	Havant	1939		1930t, 98.5x10.1x3.9m, 3b, 2gt, 34000hp, 35kts, 145p; 3x1-120/45, 2x4-12.7/62, 2x4-533TT, 4DCT, 2DCR
J	8	145	Jackal	1939		2330-2384t, 108.7x10.9x4.2m, 2b, 2gt, 40000hp, 36kts, 183-218p; 3x2-120/45, 1x4-40/39, 2x4-12.7/62, 2x5-533TT, 2DCT, 1DCR, MS
		146	Jaguar	1939		
		147	Janus	1939		
		148	Javelin	1939		
		149	Jersey	1939		
		150	Jervis	1939		
		151	Juno	1939		
		152	Jupiter	1939		
K	8	153	Kandahar	1939		2330-2384t, 108.7x10.9x4.2m, 2b, 2gt, 40000hp, 36kts, 183-218p; 3x2-120/45, 1x4-40/39, 2x4-12.7/62, 2x5-533TT, 2DCT, 1DCR, MS
		154	Kashmir	1939		
		155	Kelly	1939		
		156	Kelvin	1939		
		157	Khartoum	1939		
		158	Kimberley	1939		
		159	Kingston	1939		
		160	Kipling	1939		

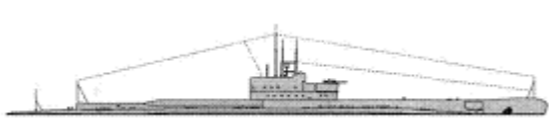
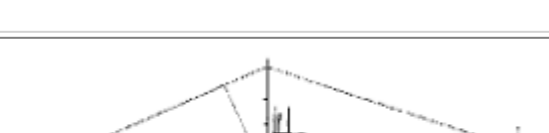
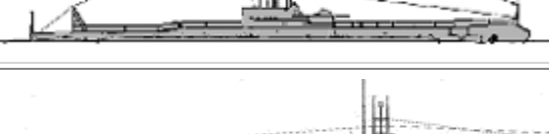
### SUBMARINES

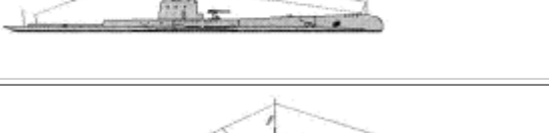

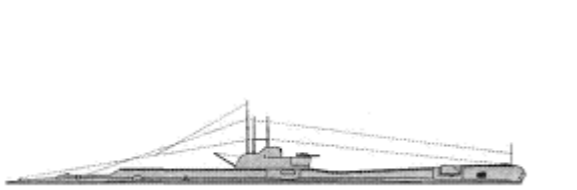

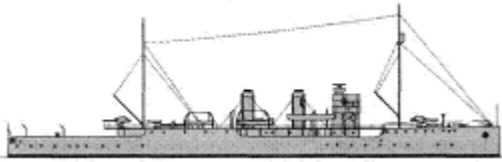
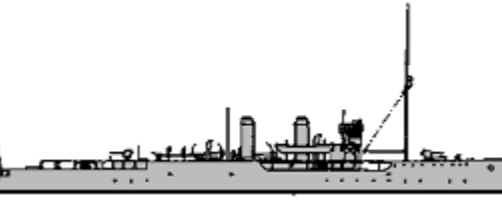
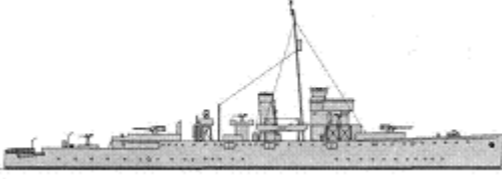
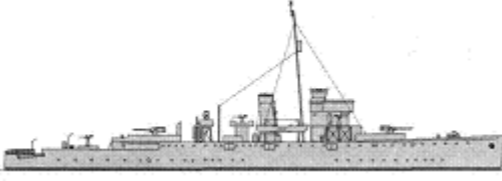
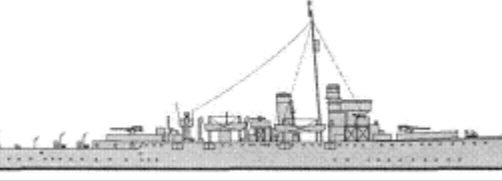

H-II	9	1	H28	1918		423/510t, 52.4x4.8x4.0m, 2d/em, 480/620hp, 11.5/10.5kts, 22p, 30m; 4-533TT
		2	H31	1919		
		3	H32	1919		
		4	H33	1919		
		5	H34	1919		
		6	H43	1919		
		7	H49	1919		
		8	H44	1920		
		9	H50	1920		
L-II	3	10	L23	1924		890/1080t, 72.7x7.2x4.0m, 2d/em, 2400/1600hp, 17/10.5kts, 38p, 50m; 1x1-102/40, 4-533TT, 2-450TT
		11	L26	1926		
		12	L27	1926		

SS	Oberon	1	13	Oberon	1927		1598/1831t, 82.2x8.5x4.7m, 2d/em, 2950/1350hp, 13.7/7.5kts, 54p, 60m; 1x1-102/40, 8-533TT	
	Oxley	1	14	Otway	1927		1636/1872t, 83.8x8.4x4.8m, 2d/em, 3100/1350hp, 15/8.5kts, 55p, 60m; 1x1-102/40, 8-533TT	
	Odin	6	15	Odin	1929			1781/2038t, 86.4x9.1x4.9m, 2d/em, 4520/1390hp, 17.5/8kts, 53p, 95m; 1x1-102/40, 8-533TT
			16	Osiris	1929			
			17	Oswald	1929			
			18	Otus	1929			
			19	Olympus	1930			
			20	Orpheus	1930			
	Parthian	5	21	Pandora	1930			1760/2040t, 88.1x9.1x4.9m, 2d/em, 4340/1635hp, 17/8.6kts, 53p, 95m; 1x1-102/40, 2x1-12.7/62, 8-533TT
			22	Perseus	1930			
			23	Proteus	1930			
			24	Parthian	1931			
			25	Phoenix	1931			
	Rainbow	4	26	Regent	1930			1763/2030t, 87.5x9.1x4.9m, 2d/em, 4100/1670hp, 17/8.8kts, 53p, 95m; 1x1-102/40, 8-533TT
			27	Regulus	1930			
			28	Rover	1931			
			29	Rainbow	1932			
	Thames	3	30	Thames	1932			2165/2680(30)-2206/2723(31, 32), 105.2x8.6x4.8(30)-4.9(31, 32)m, 2d/em, 10000/2500hp, 22.5/10(30)-22/10(31, 32)kts, 61p, 60m; 1x1-102/40, 2x1-12.7/62, 6-533TT
			31	Severn	1935			
			32	Clyde	1935			
	Swordfish	4	33	Swordfish	1932			730/927t, 61.7x7.3x3.6m, 2d/em, 1550/1440hp, 13.7/10kts, 38p, 60m; 1x1-76/45, 1x1-12.7/62, 6-533TT
			34	Sturgeon	1933			
			35	Seahorse	1933			
36			Starfish	1933				
Porpoise	1	37	Porpoise	1933			1768/2053t, 88.1x9.1x4.8m, 2d/em, 3300/1630hp, 15.5/8.7kts, 59p, 60m; 1x1-102/40, 6-533TT, 50mines	
Shark	8	38	Sealion	1934			768/960t, 63.6x7.3x3.6m, 2d/em, 1550/1440(38-43, 45)-1900/1440(44)hp, 14/10(38-43, 45)-15/10(44)kts, 39p, 60m; 1x1-76/45, 1x1-12.7/62, 6-533TT	
		39	Shark	1934				
		40	Salmon	1935				
		41	Snapper	1935				
		42	Seawolf	1936				
		43	Spearfish	1936				
		44	Sunfish	1937				
		45	Sterlet	1938				
		46	Narwhal	1936				

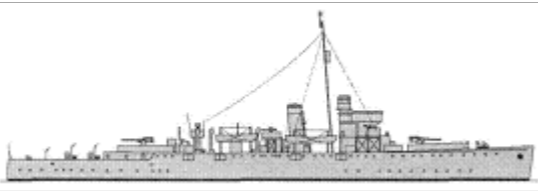
Grampus	5	47	Grampus	1937		1810/2157t, 89.3x7.8x5.1m, 2d/em, 3300/1630hp, 15.7/8.7kts, 59p, 60m; 1x1-102/40, 6-533TT, 50mines
		48	Rorqual	1937		
		49	Cachalot	1938		
		50	Seal	1939		
Triton	7	51	Triton	1938		1331/1585(51)-1326/1575(52-57)t, 84.4(51)-83.8(52-57)x8.1x4.5m, 2d/em, 2500/1450hp, 15.3/9kts, 59p, 95m; 1x1-102/40, 3x1-12.7/62, 10-533TT
		52	Tribune	1939		
		53	Trident	1939		
		54	Triumph	1939		
		55	Thistle	1939		
		56	Triad	1939		
57	Truant	1939				
Undine	3	58	Undine	1938		630/730t, 58.2x4.9x4.6m, 2dg, 2em, 615/825hp, 11.2/10kts, 27p, 60m; 1x1-76/45(60), 3x1-12.7/62, 6-533TT
		59	Unity	1938		
		60	Ursula	1938		

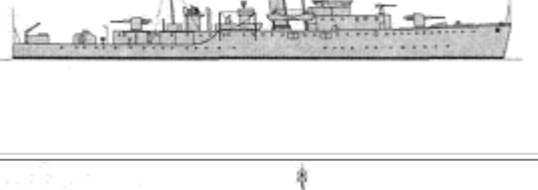
## ESCORTS

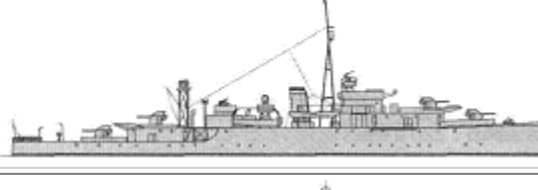
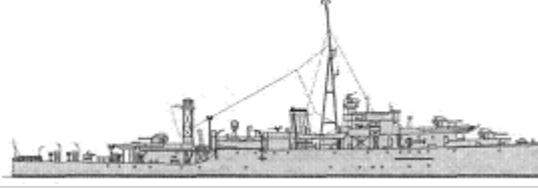
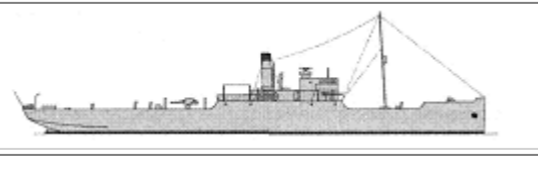
Acacia	2	1	Foxglove	1915		1275t, 80.0x10.1x3.4m, 2b, 1vte, 1800hp, 16.5kts, 90p; 2x1-102/40, 2x1-40/39, 2DCT, 1DCR, MS
		2	Laburnum	1915		
Arabis	3	3	Rosemary	1915		1350t, 81.7x10.2x3.4m, 2b, 1vte, 2000hp, 16kts, 104p; 2x1-102/40, 2x1-40/39, 2DCT, 1DCR, MS
		4	Cornflower	1916		
		5	Lupin	1916		
Bridgewater	2	6	Bridgewater	1929		1600t, 81.2x10.4x3.7m, 2b, 2gt, 2000hp, 16.5kts, 100p; 2x1-102/45, 1x4-12.7/62, 2DCT, 1DCR, MS
		7	Sandwich	1929		
Hastings	4	8	Folkestone	1930		1640t, 81.2x10.4x3.8m, 2b, 2gt, 2000hp, 16.5kts, 100p; 1x1-102/45(8, 10), 2x1-102/45(9, 11), 1x4-12.7/62, 2DCT, 1DCR, MS
		9	Hastings	1930		
		10	Scarborough	1930		
		11	Penzance	1931		
Shoreham	4	12	Fowey	1931		1590t, 85.8x10.7x3.4m, 2b, 2gt, 2000hp, 16.5kts, 100p; 2x1-102/45, 2x1-47/40, 1x4-12.7/62, 2DCT, 1DCR, MS
		13	Shoreham	1931		
		14	Bideford	1932		
		15	Rochester	1932		
		16	Falmouth	1932		

SL	Repeat Shoreham	4	17	Milford	1932		1515t, 85.8x10.7x3.4m, 2b, 2gt, 2000hp, 16.5kts, 100p; 2x1-102/45, 2x1-47/40, 1x4-12.7/62, 2DCT, 1DCR, MS
			18	Dundee	1933		
			19	Weston	1933		
	Grimsby	8	20	Grimsby	1934		1480t, 81.2x11.0x3.0m, 2b, 2gt, 2000hp, 16.5kts, 100p; 2x1-120/45(21, 23, 25), 3x1-102/45(26), 2x2-102/45(20, 22, 24, 27), 1x1-76/45(21, 23, 25), 4x1-47/40(20-25, 27), 1x4-12.7/62, 2DCT, 1DCR, 40mines(20, 22)
			21	Leith	1934		
			22	Lowestoft	1934		
			23	Deptford	1935		
			24	Londonderry	1935		
			25	Wellington	1935		
			26	Aberdeen	1936		
	27	Fleetwood	1936				
	Bittern	3	28	Enchantress	1935		1650(28)-1790(29, 30)t, 86.0x11.3x3.3(28)-3.5(29, 30)m, 2b, 2gt, 3300hp, 18.7kts, 156p; 2x1-120/45(28), 3x2-102/45(29, 30), 1x4-12.7/62, 2DCT, 1DCR
			29	Stork	1936		
30			Bittern	1938			
Egret	3	31	Auckland	1938		1790t, 89.2x11.4x3.4m, 2b, 2gt, 3600hp, 19.2kts, 188p; 4x2-102/45, 1x4-12.7/62, 2DCT, 1DCR	
		32	Egret	1938			
		33	Pelican	1939			
Flamingo	1	34	Flamingo	1939		1770t, 91.3x11.4x3.3-3.6m, 2b, 2gt, 4300hp, 19.7kts, 180p; 3x2-102/45, 1x4-40/39, 2x4-12.7/62, 4DCT, 2DCR	
FS	PC-boat	1	1	PC74	1918		780t, 75.3x8.2x2.4m, 2b, 2t, 3500hp, 20kts, 55p; 1x1-102/40, 2x1-76/40, 2x1-356TT, 2DCR
	Kingfisher	6	2	Kingfisher	1935		745t, 74.1x8.1x2.4m, 2b, 2gt, 3600hp, 20kts, 60p; 1x1-102/45, 4DCT, 2DCR
			3	Mallard	1936		
			4	Puffin	1936		
			5	Kittiwake	1937		
			6	Sheldrake	1937		
			7	Widgeon	1938		
	Shearwater	3	8	Guillemot	1939		745t, 71.1x7.8x2.7m, 2b, 2gt, 3600hp, 20kts, 60p; 1x1-102/45, 4DCT, 2DCR
			9	Pintail	1939		
10			Shearwater	1939			
		1	Chakdina	1914		3033brt, 100.8x14.1xm, 1vte, 12kts; 1x1-102/40	

ABV	-	12	2	Chakla	1914		3081brt, 100.7x14.1xm, 1vte, 12kts; 2x1-102/40
			3	Chantala	1920		3129brt, 100.6x14.0xm, 1vte, 14kts; 2x1-102/40
			4	Discovery II	1929		1036brt, 67.4x11.0xm, 1vte, 9kts; 1x1-76/40
			5	Fiona	1927		2190brt, 85.3x13.3xm, 2vte, 13kts; 1x1-102/40, 1x1-76/40
			6	Goodwin	1917		1570brt, 82.4x11.3xm, 1vte, 12.5kts; 1x1-76/40
			7	King Orry	1913		1877brt, 91.4x13.1xm, 2t, 21.5kts; 1x1-102/40
			8	Laird`s Isle	1911		1783brt, 96.3x12.5xm, 3t, 22.5kts; 1x1-102/40
			9	Mona`s Isle	1905		1688brt, 94.9x12.2xm, 3t, 22kts; 2x1-102/40, 1x1-76/40
			10	Rosaura	1905		1552brt, 83.4x10.6xm, 3t, 22kts; 1x1-102/40
			11	St. Tudno	1926		2326brt, 97.0x13.5xm, 2gt, 19kts; 2x1-102/40
			12	Van Dyck	1920		2194brt, 87.0x12.7xm, 1vte, 9kts; 2x1-102/40
			APC	-	38	1	Giang Bee
2	Holdfast	1921					1500brt, 76.3x10.8xm, 1vte, 12kts
3	Kedah	1927					2499brt, 96.6x15.4xm, 2gt, 19kts
4	Lormont	1927					1561brt, 73.6x12.3xm, 1vte, 14kts; 2x1-76/40
5	Mata Hari	1915					1020brt, 67.1x10.7xm, 1vte, 9kts
6	Pangkor	1929					1208brt, 70.7x13.0xm, 2vte, 9kts
7	St.Magnus	1924					1311brt, 73.3x11.0xm, 1vte, 13kts
8	St. Sunniva	1931					1368brt, 77.1x10.7xm, 1vte
9	Consul	1896					257brt
10	Danube III	1924					234brt
11	Danube V	1935					241brt
12	Danube VI	1935					241brt
13	Empress	1879					173brt
14	Exwey	1888					315brt
15	Flying Breeze	1913					387brt
16	Foremost	1924					211brt
17	Kampar	1915					971brt
18	Kenia	1927					200brt
19	Keverne	1908					119brt
20	Kuala	1911					954brt
21	Lipis	1927					914brt
22	Loch Aline	1904					192brt
23	Robina	1914					306brt
24	Roger Beck	1924					114brt
25	Rona	1938					180brt
26	Sir Bevois	1916					338brt
27	Sir E. P. Wills	1937					162brt
28	Sir Francis	1908					478brt

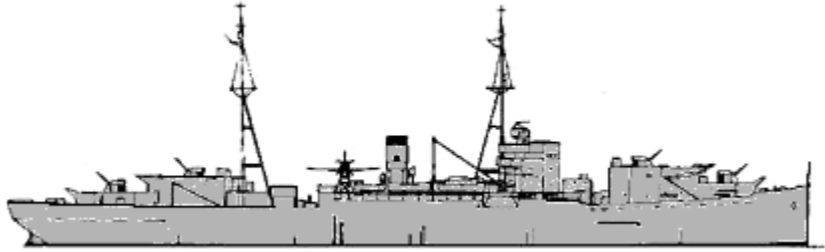

				Drake			
		29		Sir Richard Grenville	1931		896brt
		30		Sir Walter Raleigh	1908		478brt
		31		Smeaton	1883		369brt
		32		Sun III	1909		197brt
		33		Sun V	1915		200brt
		34		Sun VIII	1919		196brt
		35		Tien Kwang	1925		781brt
		36		Victor	1898		153brt
		37		Victoria	1884		229brt
		38		William Ryan	1928		102brt
SSV	-	7	1	Beaully	1924		1061brt, 73.8x10.4xm, 1vte, 11kts; 4x1-102/40, 2-533TT
			2	Botlea	1917		5119brt, 122.1x16.3xm, 1vte, 14kts; 7x1-102/40, 4-533TT
			3	Cape Howe	1930		4443brt, 114.3x16.2xm, 1vte, 13.5kts; 7x1-102/40, 4-533TT
			4	Cape Sable	1936		4398brt, 114.3x16.2xm, 1vte, 13.5kts; 7x1-102/40, 4-533TT
			5	City of Durban	1920		5945brt, 115.7x15.9xm, 1gt, 15kts; 9x1-102/40, 4-533TT
			6	Orchy	1930		1090brt, 75.1x11.0xm, 1vte, 11kts; 4x1-102/40, 2-533TT
			7	Willamette Valley	1928		4702brt, 122.3x16.5xm, 1d, 15kts; 9x1-102/40, 4-533TT
SAAAV	-	1	1	Springbank	1926		5155brt, 128.1x16.4xm, 2d, 12kts; 4x2-102/45
CAAAV	-	1	1	Conqueror	1911		900brt; 1x1-76/40
			1	St. Modwen	1911		1023t, 72.8x9.5xm, 2vte; 2x1-76/40
			2	Sea Belle II	1927		1057t; 71.0x10.2xm, 2vte; 2x1-76/40
			3	Surprise	1896		1322t; 3x1-76/40
			4	Aarla	1903		471t
			5	Adventuress	1898		322t
			6	Alice	1930		527t
			7	Alisdair	1937		120t
			8	Altair	1905		505t
			9	Anglia	1913		362t
			10	Anna Marie	1930		344t
			11	Aronia	1929		193t
			12	Attendant	1913		357t

13	Azur	1929		136t
14	Breda	1912		143t
15	Calanthe	1898		430t
16	Campeador V	1938		213t
17	Charles McIver	1936		428t
18	Coila	1922		355t
19	Cutty Sark	1920		828t
20	Cynara	1913		560t
21	Evadne	1931		581t; 1x1-76/40
22	Gelert	1881		122t
23	Glen Strathallan	1928		356t; 1x1-76/40
24	Grey Mist	1920		197t
25	Gulzar	1934		201t
26	Hiniesta	1902		361t
27	Kiloran	1930		277t
28	Lady Blanche	1907		405t
29	Lady Shahrazad	1904		439t
30	Lady Vagrant	1903		484t
31	Leprechaun	1939		100t
32	Lexa	1936		133t
33	Lorna	1904		484t; 1x1-76/40
34	Maid Marion	1938		506t
35	Mollusc	1906		627t; 1x1-76/40
36	Minona	1906		249t
37	Ombra	1902		275t
38	Oracle	1929		625t
39	Princess	1924		730t
40	Radiant	1927		550t
41	Rhodora	1929		709t
42	Rion	1928		324t
43	Rosabelle	1901		614t; 1x1-76/40
44	Sagitta	1908		756t; 2x1-76/40
45	St. Adrian	1927		387t
46	St. Dominica	1895		338t
47	Sappho	1935		327t
48	Sargasso	1926		216t





AY

67

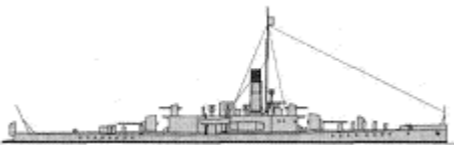
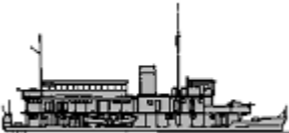



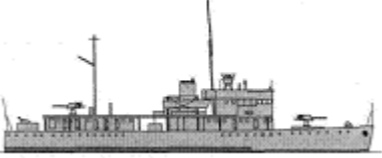

		49	Sayonara	1911		762t
		50	Schievan	1897		439t
		51	Seaflower	1882		447t
		52	Shalimar	1903		114t
		53	Shemara	1938		834t
		54	Shiona	1938		112t
		55	Sona	1922		555t
		56	Spitfire III	1938		142t
		57	Surf	1902		560t; 2x1-76/40
		58	Sylvana	1907		487t
		59	Taransay	1930		175t
		60	Tiercel	1913		489t
		61	Titan	1935		103t
		62	Valena	1908		882t
		63	Virginia	1930		712t
		64	Viva II	1929		502t
		65	Wilna	1939		461t; 1x1-102/40
		66	Yarta	1898		357t
		67	Zaza	1905		455t; 1x1-76/40

## OTHER FIGHTING SHIPS

Insect	10	1	Aphis	1915		750t, 72.4x11.0x1.2m, 2b, 2vte, 2000hp, 14kts, 54-65p; 2x1-152/40, 1x1-76/40	
		2	Gnat	1915			
		3	Mantis	1915			
		4	Scarab	1915			
		5	Cicala	1916			
		6	Cockchafer	1916			
		7	Cricket	1916			
		8	Ladybird	1916			
		9	Moth	1916			
		10	Tarantula	1916			
Peterel	2	11	Peterel	1927	No picture	400t, 56.4x8.8x1.3m, 2b, 2gt, 2250hp, 16kts, 55p; 2x1-76/45	
		12	Gannet	1928			
Tern	2	13	Seamew	1928	No picture	330t, 51.2x8.2x1.3m, 2b, 2gt, 1370hp, 14kts, 55p; 2x1-76/45	
		14	Tern	1928			
PR	Falcon	1	15	Falcon	1931		470t, 45.7x8.8x1.8m, 2b, 2gt, 2250hp, 15kts, 55p; 1x1-87/13, 2x1-57/40



	Sandpiper	1	16	Sandpiper	1933		215t, 51.0x9.4x0.6m, 1b, 2vte, 600hp, 35p; 1x1-87/13, 1x1-57/40
	Robin	1	17	Robin	1934		275t, 47.6x8/1x1/1m, 1b, 2vte, 800hp, 12.7kts, 35p; 1x1-87/13, 1x1-57/40
	Scorpion	1	18	Scorpion	1938		800t, 63.6x10.6x1.8m, 2b, 2gt, 4500hp, 17kts, 93p; 2x1-102/45, 1x1-87/13, 2x1-47/40
	Dragonfly	2	19	Dragonfly	1939		715t, 59.9x10.3x1.9m, 2b, 2gt, 3800hp, 17kts, 74p; 2x1-102/45, 1x1-87/13
			20	Grasshopper	1939		

## COASTAL FORCES

PT	CMB-70	2	1, 2	CMB103MT, 104MT	1922		24t, 22.1x4.3x1.1m, 2pe, 1400hp, 36.6kts, 5p; 1DCR, 7mines
	MTB1	18	3 - 20	MTB1 - 12, 14 - 19	1936 - 1939		20t, 18.4x4.2x0.9m, 3pe, 1650hp, 36kts, 8p; 2-450TT, 6DC
	MTB20	1	21	MTB22	1939		37t, 21.9x5.0x1.0m, 3pe, 3450hp, 42kts, 10p; 2-533TT, 8DC
	MTB24	1	22	MTB24	1939		43t, 22.6x5.1x1.0m, 3pe, 3450hp, 42kts, 12p; 1x2-12.7, 2-533TT, 2DC
	MTB26	2	23, 24	MTB26, 27	1938	No picture	17t, 16.8x3.35x1.1m, 2pe, 750hp, 38kts, 5p; 2-450TT, 2DC
PS	MA/SB1	5	1 - 5	MA/SB1 - 5	1939		19t, 18.3x4.2x0.9m, 2pe, 1100hp, 25kts, 9p; 2DCR
	MA/SB6	16	6 - 21	MA/SB6 - 21	1939		32t, 21.3x5.1x1.0m, 2pe, 1650hp, 23kts, 9p; 1x1-40/39, 2x2-12.7, 2DCR

## AMPHIBIOUS

LCU	X1	11	1	X21	1915		160t, 32.2x6.4x1.1m, 1sd, 60hp, 8kts, ?p; 500troops
			2	X31	1915		
			3	X36	1915		
			4	X45	1915		
			5	X64	1915		
			6	X95	1915		
			7	X103	1915		
			8	X131	1915		
			9	X134	1915		
			10	X140	1915		

			11	X149	1915		
	X201	6	12	X201	1916		137t, 29.6x6.1x1.1m, 1sd, 60hp, 8kts, ?p; 500troops
			13	X206	1916		
			14	X209	1916		
			15	X213	1916		
			16	X217	1916		
			17	X225	1916		
LCU(x)	DX1	2	1	DX1	1916		137t, 29.6x6.1x1.1m, ?p; 500troops
			2	DX2	1916		
LC	MLC1	1	1	MLC1	1926	No picture	26t, 12.2x3.5x0.4m, 2pe, 68hp, 4.7kts, 3p; 100troops
	MLC10	9	2 - 10	MLC10 - 12, 14 - 19	1929 - 1937	No picture	32t, 13.0x3.6x0.5m, 2pe, 68hp, 5kts, 3p; 1 12t tank or 100troops

## MINE WARFARE

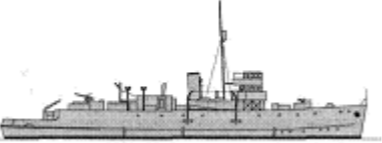
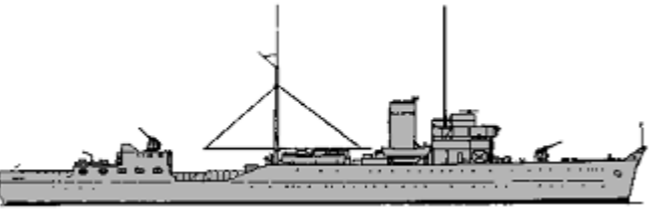
ML	M29	3	1	Medusa	1915		580t, 54.0x9.4x1.8m, 2b, 2vte, 400hp, 9kts, 72p; 50mines
			2	Melpomene	1915		
			3	Minerva	1915		
	Plover	1	4	Plover	1937		1020t, 59.5x11.4x3.1m, 2b, 2vte, 1400hp, 14.7kts, 69p; 1x1-76/45, 80mines
Linnet	3	5	Linnet	1938	No picture	600t, 49.9x8.3x2.4m, 1vte, 400hp, 10.5kts, 24p; 12mines	
		6	Redstart	1938			
		7	Ringdove	1938			
M1	1	8	M1	1939	No picture	346t, 33.6x8.1x2.4m, 2diesels, 360hp, 10kts, 32p; 10mines	
AML -		8	1	Hampton	1934		2839brt, 105.8x18.5xm, 2gt, 16.5kts; 1x1-102/40, 270mines
			2	Menestheus	1929		13735t, 140.2x18.1xm, 2d, 15.5kts; 2x1-102/45, 2x1-40/39, 410mines
			3	Port Quebec	1939		8490t, 142.6x18.1xm, 1d, 16kts; 2x1-102/45, 2x1-40/39, 548mines
			4	Princess Victoria	1939		2197brt, 93.0x14.6xm, 2d, 19kts; 2x1-76/40, 244mines
			5	Shepperton	1934		2839brt, 105.8x18.5xm, 2gt, 16.5kts; 1x1-102/45, 270mines
			6	Teviotbank	1937		5087brt, 130.8x17.8xm, 1vte, 15kts; 1x1-102/40, 1x1-76/40, 280mines
			7	Atreus	1911		645brt; 1x1-76/40, 192mines
			8	Manyeung	1933		371t
NL	Guardian	1	1	Guardian	1933		3665t, 103.0x16.2x4.2m, 2b, 2gt, 6500hp, 18kts, 181p; 2x1-102/45, nets

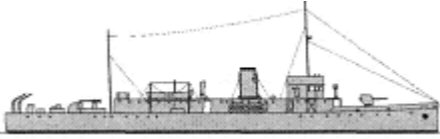
	Protector	1	2	Protector	1936		3610t, 103.0x16.2x4.2m, 2b, 2gt, 9000hp, 20kts, 190p; 1x1-102/45, nets
MS	Hunt-II	24	1	Aberdare	1918		930t, 70.4x8.7x2.3m, 2b, 2vte, 2200hp, 16kts, 74p; 1x1-102/40, 1x1-76/40, MS
			2	Abingdon	1918		
			3	Derby	1918		
			4	Fareham	1918		
			5	Harrow	1918		
			6	Pangbourne	1918		
			7	Saltash	1918		
			8	Stoke	1918		
			9	Sutton	1918		
			10	Widnes	1918		
			11	Albury	1919		
			12	Alresford	1919		
			13	Bagshot	1919		
			14	Dundalk	1919		
			15	Dunoon	1919		
			16	Elgin	1919		
			17	Fermoy	1919		
			18	Huntley	1919		
			19	Lydd	1919		
			20	Fitzroy	1919		
			21	Kellett	1919		
			22	Ross	1919		
			23	Saltburn	1919		
			24	Selkirk	1919		
	Halcyon	21	25	Halcyon	1934		1088(25-31)-1190(32-45)t, 74.8x10.2x3.1m, 2b, 2vc(25-29)-2vte(30, 31)-2gt(32-45), 1770(25-29)-2000(30, 31)-1750(32-45)hp, 16.5(25-29)-17(30-45)kts, 80p; 2x1-102/45, 1x4-12.7/62(32-45), MS
26			Harrier	1934			
27			Skipjack	1934			
28			Hussar	1935			
29			Speedwell	1935			
30			Niger	1936			
31			Salamander	1936			
32			Hazard	1937			
33			Hebe	1937			
34			Sharpshooter	1937			
35			Franklin	1938			

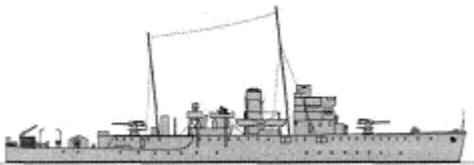
36	Gleaner	1938		
37	Gossamer	1938		
38	Jason	1938		
39	Leda	1938		
40	Seagull	1938		
41	Bramble	1939		
42	Britomart	1939		
43	Scott	1939		
44	Speedy	1939		
45	Sphinx	1939		
46	Raub	1926		1161brt, 70.7x13.0xm, 2vte
47	Circe	1912		778t; 1x1-102/40
48	Hua Tong	1927		280t
49	Malacca	1927		211t
50	Nguvu	1925		179t
51	Salvo	1918		161t
52	Scythe	1915		100t
53	Shako	1913		121t
54	Sin Aik Lee	1928		198t
55	Slogan	1926		110t
56	Souvenir	1914		120t
57	Tapah	1926		208t
58	William Scoresby	1926		326t
59	Zerang	1938		261t
60	Ambassador	1911		387t; 1x1-76/40
61	Brighton Belle	1900		396t
62	Brighton Queen	1905		807t
63	City of Rochester	1904		235t
64	Devonia	1905		520t; 1x1-76/40
65	Duchess of Fife	1903		336t
66	Duches of Rothesay	1894		385t
67	Emperor of India	1906		534t; 1x1-76/40
68	Essex Queen	1897		389t
69	Glen Avon	1912		509t; 1x1-76/40
70	Glen Gower	1922		553t; 1x1-76/40



AMS -

49

			71	Glen Usk	1914		524t; 1x1-76/40
			72	Goatfell	1934		624t; 1x1-76/40
			73	Gracie Fields	1936		393t
			74	Helvellyn	1937		642t
			75	Jeannie Deans	1931		635t
			76	Kylemore	1897		319t
			77	Laguna Belle	1896		617t; 1x1-76/40
			78	Lorna Doone	1891		410t
			79	Marmion	1906		409t; 1x1-76/40
			80	Medway Queen	1924		318t
			81	Mercury	1934		621t
			82	Oriole	1910		441t
			83	Plinlimmon	1895		436t; 1x1-76/40
			84	Princess Elizabeth	1927		388t
			85	Queen Empress	1912		411t
			86	Queen of Kent	1916		798t; 1x1-76/40
			87	Queen of Thanet	1916		792t
			88	Sandown	1934		684t; 1x1-76/40
			89	Scawfell	1937		642t; 1x1-76/40
			90	Skiddaw	1896		483t; 1x1-76/40
			91	Snaefell	1907		466t; 1x1-76/40
			92	Thames Queen	1898		517t; 1x1-76/40
			93	Waverley	1899		537t
			94	Westward Ho!	1894		438t; 1x1-76/40
MDV	-	1	1	Borde	1920		2014brt; 82.4x11.6xm, 1vte, 9kts; 2x1-76/40, 2x1-40/39
	Mersey	11	1	Moy	1917		665t, 45.1x7.2x2.8m, 1b, 1vte, 600hp, 11kts, ?p; 1x1-76/40, MS
			2	Ouse	1917		
			3	Doon	1917		
			4	Excellent	1918		
			5	Stour	1918		
			6	Colne	1918		
			7	Cherwell	1918		
			8	Foyle	1918		
			9	Eden	1918		
			10	Blackwater	1918		
			11	Boyne	1918		
			12	Alexander Scott	1917		
			13	Davied Ogilvie	1917		
			14	Neil Smith	1917		

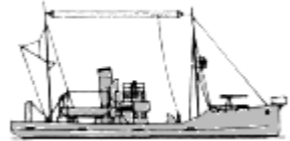

Castle	23	15	William Bunce	1917		547t, 40.8x7.2x2.8m, 1b, 1vte, 480hp, 10.5kts, ?p; 1x1-76/40, MS
		16	William Cale	1917		
		17	Arthur Cavanagh	1918		
		18	Charles Boyes	1918		
		19	James Lay	1918		
		20	John Baptist	1918		
		21	John Cattling	1918		
		22	Joseph Button	1918		
		23	Phineas Beard	1918		
		24	Richard Crofts	1918		
		25	Robert Bowen	1918		
		26	Thomas Bartlett	1918		
		27	Daniel Clowden	1919		
		28	George Cousins	1919		
		29	Michael Griffiths	1919		
		30	Peter Carey	1919		
		31	Thomas Leeds	1919		
32	Madras	1919				
33	Sealdah	1919				
34	Thomas Altoft	1920				
Strath	2	35	Benjamin Coleman	1917	No picture	429t, 37.5x6.8x2.8m, 1b, 1vte, 430hp, 10kts, ?p; 1x1-76/40, 1DCT, MS
		36	William Hanbury	1918		
Axe	4	37	Dee	1916		520t, 42.3x7.2x3.7m, 1b, 1vte, 490hp, 10.5kts, 20p; 1x1-75/50, MS
		38	Garry	1916		
		39	Kennet	1916		
		40	Liffey	1916		
Cedar	21	41	Alder	1929		500t; 1x1-76/40, MS
		42	Beech	1929		540t; 1x1-76/40, MS
		43	Berberis	1928		540t; 1x1-102/40, MS
		44	Cedar	1933		649t; 1x1-76/40, MS
		45	Cypress	1930		570t; 1x1-76/40, MS
		46	Guava	1933		394t; 1x1-76/40, MS
		47	Hawthorn	1930		593t; 1x1-102/40, MS
		48	Holly	1930		590t; 1x1-76/40, MS
		49	Hornbeam	1930		530t; 1x1-76/40, MS
		50	Larch	1928		359t; 1x1-76/40, MS
		51	Laurel	1930		590t; 1x1-102/40, MS
		52	Lilac	1930		593t; 1x1-102/40, MS
		53	Magnolia	1930		557t; 1x1-102/40, MS

		54	Maple	1929		550t; 1x1-102/40, MS
		55	Myrtle	1928		550t; 1x1-76/40, MS
		56	Oak	1928		545t; 1x1-102/40, MS
		57	Redwood	1928		555t; 1x1-102/40, MS
		58	Sycamore	1930		573t; 1x1-102/40, MS
		59	Syringa	1930		574t; 1x1-76/40, MS
		60	Tamarisk	1929		540t; 1x1-76/40, MS
		61	Willow	1930		574t; 1x1-76/40, MS
Agate	15	62	Agate	1934		627t; 1x1-102/40, DCR
		63	Amber	1933		700t; 1x1-102/40, DCR
		64	Amethyst	1934		627t; 1x1-102/40, DCR
		65	Beryl	1933		615t; 1x1-102/40, DCR
		66	Coral	1935		705t; 1x1-102/40, DCR
		67	Cornelian	1933		568t; 1x1-102/40, DCR
		68	Jade	1933		613t; 1x1-102/40, DCR
		69	Jasper	1931		581t; 1x1-102/40, DCR
		70	Moonstone	1934		615t; 1x1-102/40, DCR
		71	Pearl	1933		649t; 1x1-102/40, DCR
		72	Ruby	1933		568t; 1x1-102/40, DCR
		73	Sapphire	1934		608t; 1x1-102/40, DCR
		74	Topaze	1934		608t; 1x1-102/40, DCR
		75	Tourmaline	1935		641t; 1x1-102/40, DCR
		76	Turquoise	1935		641t; 1x1-102/40, DCR
Basset	1	77	Basset	1935		725-775t, 48.9-50.0x8.3-8.4x3.2-3.4m, 1b, 1vte, 850-950hp, 12.5-13kts, 33p; 1x1-102/40, 2DCT, 2DCR, MS
Tree	2	78	Rowan	1939		770t, 50.0x8.4x3.4m, 1b, 1vte, 850hp, 12.2kts, 35p; 1x1-76/40, 1x2-12.7/62, 2DCT, 2DCR, MS
		79	Walnut	1939		
		80	Abronia	1906		242t
		81	Acroite	1934		334t; 1x1-76/40
		82	Admiral Sir John Lawford	1930		338t; 1x1-76/40
		83	Agnes Wickfield	1909		219t
		84	Akita	1939		314t; 1x1-76/40
		85	Akranes	1929		358t
		86	Alafoss	1929		357t; 1x1-76/40
		87	Alcmaria	1916		148t
		88	Alexandrite	1933		313t
		89	Alex Hastie	1914		206t
		90	Alfredian	1913		293t; 1x1-76/40

91	Almandine	1932		295t
92	Aloutte	1939		520t; 1x1-102/40
93	Andradite	1934		313t; 1x1-76/40
94	Angle	1936		531t
95	Annabelle	1917		202t
96	Anson	1905		211t
97	Aquamarine	1927		357t
98	Arab	1936		531t
99	Arctic Explorer	1937		501t; 1x1-102/40
100	Arctic Hunter	1929		356t; 1x1-76/40
101	Arctic Pioneer	1937		501t
102	Arctic Ranger	1937		493t
103	Argyllshire	1938		540t
104	Arkwright	1930		370t; 1x1-76/40
105	Arley	1914		304t; 1x1-76/40
106	Arnold Bennett	1930		374t; 1x1-76/40
107	Arsenal	1933		389t
108	Asama	1929		303t
109	Aston Villa	1937		546t; 1x1-102/40
110	Athelstan	1911		202t
111	Athenian	1919		218t
112	Avanturine	1934		412t
113	Avola	1913		255t
114	Avon Stream	1915		249t
115	Ayrshire	1938		540t; 1x1-102/40
116	Balmoral	1916		222t
117	Bandolero	1935		440t
118	Barbados	1905		211t
119	Beathwood	1912		209t
120	Bedfordshire	1935		443t; 1x1-102/40
121	Belldock	1917		236t
122	Bellona	1907		184t
123	Ben Ardna	1917		226t
124	Ben Bheulah	1917		275t
125	Ben Dearg	1920		280t
126	Ben Glas	1917		234t
127	Ben Gulvain	1914		197t
128	Ben Heilem	1919		224t
129	Ben Indris	1931		232t
130	Ben Torc	1915		199t

131	Bengal	1905	211t
132	Bengali	1937	455t
133	Benvolio	1930	352t
134	Berenga	1917	227t
135	Berkshire	1936	466t
136	Bernard Shaw	1929	335t
137	Beru	1911	195t
138	Bervi Braes	1917	203t
139	Betty Inglis	1895	104t
140	Blackburn Rovers	1934	422t
141	Blackfly	1937	482t
142	Bombay	1907	229t
143	Boreas	1907	184t
144	Botanic	1928	348t
145	Brabant	1918	280t
146	Braconhill	1919	203t
147	Braconlynn	1913	206t
148	Braconmoor	1917	194t
149	Bradman	1937	452t
150	Braes O`Mar	1915	227t
151	Brecon Castle	1916	274t
152	Brimnes	1933	413t; 1x1-102/40
153	British	1930	406t
154	British Guiana	1936	146t
155	British Honduras	1930	147t
156	Brock	1914	304t
157	Brontes	1934	428t
158	Bucentaur	1907	184t
159	Buckingham	1930	253t
160	Burke	1930	363t
161	Caerphilly Castle	1919	275t
162	Caldy	1908	222t
163	Calverton	1913	214t
164	Calvi	1930	363t
165	Cambridgeshire	1935	443t; 1x1-102/40
166	Campina	1913	290t
167	Cape Argona	1936	494t; 1x1-102/40
168	Cape Barracouta	1930	390t; 1x1-76/40

169	Cape Chelyuskin	1936		494t; 1x1-102/40
170	Cape Comorin	1936		504t; 1x1-102/40
171	Cape Melville	1929		342t; 1x1-76/40
172	Cape Nyemetski	1934		422t; 1x1-102/40
173	Cape Palliser	1936		497t; 1x1-102/40
174	Cape Passaro	1939		590t; 1x1-102/40
175	Cape Portland	1936		497t; 1x1-102/40
176	Cape Siretoko	1939		590t
177	Cape Spartel	1929		346t; 1x1-76/40
178	Cape Warwick	1936		515t; 1x1-102/40
179	Capricornus	1917		220t
180	Cardiff Castle	1919		276t
181	Carisbrooke	1928		230t; 1x1-76/40
182	Castleton	1904		211t
183	Cayton Wyke	1932		373t; 1x1-76/40
184	Cedric	1905		230t
185	Celtia	1907		239t
186	Cerisio	1915		338t
187	Chalcedony	1928		357t; 1x1-76/40
188	Chandos	1919		200t
189	Chassiron	1913		258t
190	Christania T. Purdy	1917		213t
191	City of Aberdeen	1898		194t
192	Claire	1907		219t
193	Cleopatra II	1907		240t
194	Clevela	1930		387t; 1x1-76/40
195	Clifton	1915		194t
196	Clyne Castle	1929		307t; 1x1-76/40
197	Clythness	1920		276t
198	Comet	1924		301t
199	Comitatus	1919		290t
200	Commander Evans	1924		344t; 1x1-76/40
201	Commiles	1918		224t
202	Commodator	1918		281t
203	Computator	1919		286t
204	Concertator	1917		275t
205	Coniston	1904		217t
206	Conquistador	1915		224t

207	Conway	1904		228t
208	Conway Castle	1916		274t
209	Cordela	1930		355t; 1x1-76/40
210	Corena	1924		352t; 1x1-76/40
211	Cortina	1913		213t
212	Courtier	1929		225t; 1x1-76/40
213	Coventry City	1937		546t
214	Craik	1915		219t
215	Cranefly	1917		312t
216	Crestflower	1930		367t; 1x1-76/40
217	Crevette	1918		203t
218	Curtana	1929		354t; 1x1-76/40
219	Dalmatia	1928		357t; 1x1-76/40
220	Damito	1917		275t
221	Daneman	1937		516t; 1x1-102/40
222	Darnett Ness	1920		277t
223	Darogah	1914		221t
224	Dartheta	1929		373t; 1x1-76/40
225	Darwen	1916		227t
226	Dav	1936		450t
227	Delphinus	1906		257t
228	Derby County	1938		299t; 1x1-102/40
229	Desiree	1912		212t
230	Donna Nook	1916		307t; 1x1-76/40
231	Dorinda	1917		270t; 1x1-76/40
232	Doris	1897		174t
233	Drangey	1935		434t
234	Drummer Boy	1916		209t
235	Dulcibelle	1918		203t
236	Earl Essex	1914		225t
237	Earl Kitchener	1915		348t; 1x1-76/40
238	Eastcoates	1919		277t
239	Ebor Wyke	1929		348t; 1x1-76/40
240	Edwardian	1931		348t; 1x1-76/40
241	Edward Walmsley	1919		276t; 1x1-76/40
242	Egeria	1907		184t
243	Elbury	1925		394t
244	Elizabeth Angela	1928		253t; 1x1-76/40
245	Elk	1902		181t

246	Else Rykens	1935		266t
247	Emilion	1914		201t
248	Emphyrean	1914		215t
249	Epine	1929		358t
250	Equerry	1929		369t
251	Erillus	1914		201t
252	Erimo	1930		265t; 1x1-76/40
253	Etruscan	1913		202t
254	Evelina	1919		202t
255	Evelyn Rose	1918		327t; 1x1-76/40
256	Everton	1915		240t
257	Evesham	1915		239t
258	Exyahne	1914		226t; 1x1-76/40
259	Fane	1930		310t
260	Faraday	1916		322t
261	Fentonian	1912		221t
262	Fezenta	1914		228t
263	Fifeshire	1938		540t
264	Filey Bay	1931		370t; 1x1-76/40
265	Firefly	1930		394t
266	Flanders	1920		289t
267	Fleming	1929		356t; 1x1-76/40
268	Florio	1916		314t; 1x1-76/40
269	Flying Wing	1915		226t
270	Fort Robert	1918		203t
271	Fort Royal	1931		351t; 1x1-76/40
272	Friarage	1930		210t
273	Fyldea	1930		377t
274	Gadfly	1919		290t
275	Gadra	1909		219t
276	Gallinule	1907		238t
277	Garola	1912		249t
278	Gaul	1936		531t; 1x1-102/40
279	Gava	1920		256t; 1x1-76/40
280	General Birdwood	1919		324t; 1x1-76/40
281	George Robb	1930		217t; 1x1-76/40
282	Georgette	1918		203t
283	Gillian	1919		206t
284	Glatian	1913		220t
285	Glen Kidston	1930		360t; 1x1-76/40

286	Goosander	1908		238t
287	Goth	1925		394t; 1x1-76/40
288	Guava	1935		134t
289	Gulfoss	1929		358t; 1x1-76/40
290	Gunner	1927		350t; 1x1-76/40
291	Gwenllian	1911		220t
292	Hammond	1936		452t; 1x1-102/40
293	Hampshire	1934		425t; 1x1-102/40
294	Harry Melling	1919		275t
295	Hatano	1925		297t; 1x1-76/40
296	Hatsuse	1927		295t; 1x1-76/40
297	Henriette	1918		204t
298	Hertfordshire	1936		458t; 1x1-102/40
299	Hildina	1918		276t
300	Holyrood	1914		210t; 1x1-76/40
301	Honjo	1928		308t; 1x1-76/40
302	Hoverfly	1917		242t
303	Huddersfield Town	1933		399t
304	Hugh Walpole	1937		498t; 1x1-102/40
305	Hyaena	1903		183t
306	Ijuin	1920		282t
307	Imperia	1912		213t
308	Imperialist	1939		520t; 1x1-102/40
309	Inchgower	1919		202t
310	Indian Star	1936		463t; 1x1-102/40
311	Inverforth	1914		248t
312	Iranian	1912		202t
313	Istria	1935		409t; 1x1-102/40
314	Jardine	1936		452t; 1x1-102/40
315	Kelt	1937		455t; 1x1-102/40
316	Kennymore	1914		255t
317	Manly	1902		190t; 1x1-76/40
318	Kingscourt	1917		203t
319	Kings Grey	1915		338t; 1x1-76/40
320	King Sol	1937		486t
321	Kingston Agate	1937		464t; 1x1-102/40
322	Kingston Alalite	1933		412t
323	Kingston Amber	1937		467t; 1x1-102/40
324	Kingston Andalusite	1934		415t



TL

325	Kingston Beryl	1928		356t
326	Kingston Cairngorm	1935		448t; 1x1-102/40
327	Kingston Ceylonite	1935		448t; 1x1-102/40
328	Kingston Chrysoberyl	1935		448t; 1x1-102/40
329	Kingston Chrysolite	1935		448t
330	Kingston Coral	1936		433t; 1x1-102/40
331	Kingston Cornelian	1934		449t
332	Kingston Crystal	1936		433t
333	Kingston Cyanite	1936		433t
334	Kingston Galena	1934		415t; 1x1-102/40
335	Kingston Jasinth	1929		356t
336	Kingston Olivine	1930		378t; 1x1-102/40
337	Kingston Onyx	1928		357t
338	Kingston Peridot	1929		356t
339	Kingston Sapphire	1929		356t
340	Kingston Topaz	1927		357t
341	Kingston Turquoise	1929		356t
342	Kingsway	1905		211t
343	Kirkella	1936		436t; 1x1-102/40
344	Kunishi	1927		303t; 1x1-76/47
345	Kurd	1930		352t; 1x1-76/40
346	Lacennia	1931		348t; 1x1-76/40
347	Lady Beryl	1935		417t; 1x1-102/40
348	Lady Elsa	1937		518t
349	Lady Enid	1929		354t
350	Lady Hogarth	1937		472t; 1x1-76/40
351	Lady Philomena	1936		417t; 1x1-102/40
352	Lapwing	1904		217t
353	Larwood	1936		452t; 1x1-102/40
354	Leeds United	1933		405t
355	Leicester City	1934		422t
356	Leo	1904		181t
357	Leonora	1904		217t
358	Lephreto	1917		275t; 1x1-76/40

	359	Le Tiger	1937		516t; 1x1-102/40
	360	Leyland	1936		452t; 1x1-102/40
	361	Libra	1912		211t
576	362	Libyan	1913		202t
	363	Liddoch	1919		202t
	364	Lincoln City	1933		398t
	365	Lincolnshire	1936		432t; 1x1-102/40
	366	Loch Alsh	1926		358t; 1x1-76/40
	367	Loch Buie	1919		277t
	368	Loch Eribol	1929		352t
	369	Loch Esk	1912		209t
	370	Loch Hope	1915		274t
	371	Loch Inver	1930		356t; 1x1-76/40
	372	Loch Leven	1928		357t
	373	Loch Melfort	1934		440t
	374	Loch Monteith	1936		531t; 1x1-102/40
	375	Loch Naver	1919		278t
	376	Loch Oskaig	1936		534t; 1x1-102/40
	377	Loch Tulla	1934		423t
	378	Longscar	1930		215t
	379	Lord Ashfield	1929		346t; 1x1-76/40
	380	Lord Austin	1937		473t
	381	Lord Beaconsfield	1915		302t; 1x1-76/40
	382	Lord Cecil	1916		228t
	383	Lord Essenden	1936		464t
	384	Lord Inchcape	1924		338t
	385	Lord Irwin	1928		346t
	386	Lord Lloyd	1933		396t
	387	Lord Melchett	1928		347t; 1x1-76/40
	388	Lord Middleton	1936		464t; 1x1-102/40
	389	Lord Northcliffe	1916		228t
	390	Lord Nuffield	1937		466t
	391	Lord Plender	1933		396t
	392	Lord Snowden	1934		444t
	393	Lord Stamp	1935		448t
	394	Lord Stanhope	1935		448t
	395	Lord Stonehaven	1934		444t
	396	Lord Wakefield	1933		418t
	397	Lorinda	1928		348t

398	Ludalady	1914	234t
399	Luda Lord	1913	224t
400	Lune	1930	310t
401	Lydiard	1935	440t
402	Malacolite	1917	248t
403	Manor	1913	314t
404	Man O`War	1936	517t; 1x1-102/40
405	Manx Prince	1910	221t
406	Marano	1916	245t
407	Maretta	1929	350t
408	Marlborough	1907	213t
409	Marsona	1918	276t
410	Marie A. Hastie	1930	244t; 1x1-76/40
411	Median	1919	217t
412	Melbourne	1936	466t
413	Mikasa	1915	274t
414	Milford Countess	1919	275t
415	Milford Duchess	1919	275t
416	Milford Duke	1918	277t
417	Milford Earl	1919	290t
418	Milford King	1917	275t
419	Milford Prince	1920	278t
420	Milford Princess	1924	301t
421	Milford Queen	1917	280t
422	Mirabelle	1918	203t
423	Monimia	1929	374t; 1x1-76/40
424	Mount Keen	1936	358t
425	Murmansk	1929	348t; 1x1-76/40
426	Muroto	1931	340t
427	Nab Wyke	1930	348t; 1x1-76/40
428	Nairana II	1913	225t
429	Natal II	1903	208t
430	Negro	1932	402t; 1x1-76/40
431	Neil Mackay	1935	266t
432	New Comet	1915	244t
433	Nodzu	1929	303t
434	Nogi	1923	299t
435	Norse	1930	351t
436	Northcoates	1918	277t
437	Northern Chief	1936	655t; 1x1-102/40

438	Northern Dawn	1936		655t; 1x1-102/40
439	Northern Duke	1936		655t; 1x1-102/40
440	Northern Foam	1936		655t; 1x1-102/40
441	Northern Gem	1936		655t; 1x1-102/40
442	Northern Gift	1936		655t; 1x1-102/40
443	Northern Isles	1936		655t; 1x1-102/40
444	Northern Pride	1936		655t; 1x1-102/40
445	Northern Princess	1936		655t; 1x1-102/40
446	Northern Reward	1936		655t; 1x1-102/40
447	Northern Sky	1936		655t; 1x1-102/40
448	Northern Spray	1936		655t; 1x1-102/40
449	Northern Sun	1936		655t; 1x1-102/40
450	Northern Wave	1936		655t; 1x1-102/40
451	North Ness	1917		275t; 1x1-76/40
452	Northward	1906		204t
453	Northward Ho!	1919		204t
454	Norwich City	1937		541t; 1x1-102/40
455	Notts County	1938		541t; 1x1-102/40
456	Ocean Victor	1918		202t
457	Ohm	1915		302t
458	Oku	1929		303t
459	Olden Times	1919		202t
460	Olvina	1934		425t
461	Olympia	1917		261t; 1x1-76/40
462	Onetos	1913		217t
463	Onward II	1905		209t
464	Ophir II	1906		213t
465	Ormonde	1906		250t
466	Osta	1915		230t
467	Othello	1907		201t
468	Our Bairns	1917		275t
469	Overdale Wyke	1924		338t; 1x1-76/40
470	Patti	1929		339t; 1x1-76/40
471	Paul Rykens	1935		466t; 1x1-102/40
472	Paynter	1937		472t
473	Pelton	1925		358t
474	Pentland Firth	1934		485t; 1x1-102/40
475	Peridot	1933		398t
476	Peter Hendricks	1935		266t

477	Pict	1936		462t; 1x1-102/40
478	Picton Castle	1928		307t; 1x1-76/40
479	Pointz Castle	1914		283t; 1x1-76/40
480	Polly Johnson	1919		290t
481	Preston North End	1934		419t; 1x1-76/40
482	Prince Leo	1913		218t
483	Pyrope	1932		295t; 1x1-76/40
484	Radnor Castle	1017		275t
485	Raetia	1912		295t; 1x1-76/40
486	Raglan Castle	1919		280t
487	Ralco	1912		228t; 1x1-76/40
488	Raymont	1916		226t
489	Rayon d'Or	1912		342t
490	Reboundo	1920		278t
491	Recono	1916		248t
492	Recordo	1910		230t
493	Red Gauntlet	1930		338t; 1x1-76/40
494	Refundo	1916		258t
495	Regal	1933		409t
496	Regardo	1915		248t
497	Reighton Wyke	1937		465t
498	Relonzo	1914		245t; 1x1-76/40
499	Remexo	1912		251t
500	Resolvo	1913		231t
501	Resparko	1916		248t
502	Restrivo	1914		245t
503	Retako	1914		245t
504	Returno	1914		244t
505	Revello	1910		230t
506	Rifsnes	1932		431t; 1x1-76/40
507	Righto	1920		278t
508	Rinovia	1931		429t
509	River Clyde	1919		276t
510	River Garry	1918		203t
511	River Leven	1918		202t
512	River Ness	1918		203t
513	River Hastie	1912		210t
514	Robert Stroud	1930		219t
515	Rodino	1913		230t; 1x1-76/40
516	Ronso	1915		248t

517	Rose of England	1908		222t
518	Roxano	1907		228t
519	Royallieu	1907		211t; 1x1-76/40
520	Royalo	1916		248t
521	Rudilais	1920		282t
522	Runswick Bay	1929		349t
523	Rutlandshire	1936		458t; 1x1-102/40
524	Sabreur	1916		188t
525	St. Achilleus	1934		484t; 1x1-102/40
526	St. Amandus	1933		400t
527	St. Andronicus	1933		398t
528	St. Arcadius	1934		399t
529	St. Attalus	1934		399t
530	St. Cathan	1936		565t; 1x1-102/40
531	St. Donats	1924		349t
532	St. Elstan	1937		564t; 1x1-102/40
533	St. Goran	1936		565t
534	St. Katharine	1927		337t
535	St. Kenan	1936		565t
536	St. Loman	1936		565t
537	St. Melante	1927		358t; 1x1-76/40
538	St. Minver	1919		325t; 1x1-76/40
539	St. Wistan	1937		567t; 1x1-76/40
540	Sandringham	1930		254t
541	Sangarius	1915		211t
542	Sanson	1907		231t
543	Sansonnet	1916		212t
544	Saon	1933		386t
545	Sarah Hide	1921		162t
546	Sargon	1913		297t
547	Sasebo	1928		308t; 1x1-76/40
548	Sata	1931		340t
549	Saturn	1916		230t
550	Sawfly	1928		307t
551	Saxonia	1900		197t
552	Scalby Wyke	1935		443t
553	Scottish	1937		558t; 1x1-102/40
554	Sea King	1916		321t
555	Sedgefly	1939		520t; 1x1-102/40
556	Sedock	1920		202t

557	Semnos	1914	216t
558	Serapion	1900	195t
559	Shamrock	1899	184t
560	Sicyon	1930	344t
561	Silicia	1913	250t
562	Sindonis	1934	440t; 1x1-102/40
563	Sir John Lister	1919	281t
564	Sisapon	1928	326t
565	Slebech	1908	222t
566	Solomon	1928	357t
567	Solon	1931	348t; 1x1-76/40
568	Spaniard	1937	455t; 1x1-102/40
569	Spurs	1933	399t
570	Stafnes	1936	456t
571	Star of Deveron	1915	220t
572	Star of Orkney	1936	273t
573	Stella Canopus	1936	418t
574	Stella Capella	1937	440t; 1x1-102/40
575	Stella Carina	1936	440t; 1x1-76/40
576	Stella Dorado	1935	416t
577	Stella Leonis	1928	345t
578	Stella Orion	1935	417t
579	Stella Pegasi	1935	441t; 1x1-76/40
580	Stella Rigel	1926	358t; 1x1-76/40
581	Stella Sirius	1934	404t
582	Stoke City	1935	422t; 1x1-102/40
583	Stonefly	1930	238t
584	Stormcock	1908	188t
585	Strathmaree	1914	210t
586	Sturdee	1919	202t
587	Sturton	1920	251t
588	Suma	1927	302t; 1x1-76/40
589	Sunlight	1918	203t
590	Suzette	1920	199t
591	Syrian	1918	324t
592	Taipo	1916	225t
593	Tamora	1920	275t
594	Tartan	1912	202t
595	Tehana	1929	333t; 1x1-76/40
596	Tekoura	1929	368t
597	Teroma	1919	276t

598	Tervani	1930		409t; 1x1-76/40
599	Tewera	1930		335t; 1x1-76/40
600	Their Merit	1919		275t
601	The Roman	1909		224t
602	The Tower	1919		201t
603	Thornwyck Bay	1936		437t
604	Thrifty	1916		139t
605	Thuringia	1933		396t
606	Tilburyness	1918		279t
607	Tokio II	1906		221t
608	Tranio	1918		275t
609	Transvaal	1916		250t
610	Trevo Terceiro	1912		296t
611	T. R. Ferrens	1918		279t
612	Tritelias	1916		210t
613	Triton	1907		230t
614	Tumby	1918		204t
615	Turcoman	1937		455t; 1x1-102/40
616	Ugie Bank	1913		205t
617	Valdora	1916		251t
618	Valesca	1916		188t
619	Valmont	1916		245t
620	Varanga	1929		361t
621	Varanis	1910		258t
622	Vascama	1935		447t; 1x1-102/40
623	Velia	1914		289t; 1x1-76/40
624	Venture	1905		193t
625	Victorian	1935		447t
626	Victrix	1937		472t; 1x1-102/40
627	Viola	1905		228t
628	Vireo	1912		192t
629	Visenda	1937		455t; 1x1-102/40
630	Viviana	1936		452t
631	Wallena	1914		225t
632	Wardour	1911		335t
633	War Duke	1917		246t
634	Warwick Deeping	1934		445t
635	Warwickshire	1936		466t
636	War Wing	1915		226t
637	Waterfly	1931		387t



638	Waveflower	1929		368t
639	Weazel	1903		196t
640	Wellard	1937		514t
641	Wellsbach	1930		369t
642	Westella	1934		413t
643	William Stephen	1917		235t
644	William Wesley	1930		364t; 1x1-76/40
645	Windward Ho!	1920		263t
646	Witham	1919		205t
647	Withernsea	1918		257t
648	Wolborough	1937		459t
649	Wolves	1934		422t
650	Woods	1918		203t
651	Wyoming	1915		302t; 1x1-76/40
652	Yashima	1929		303t
653	Yesso	1918		209t
654	Yezo	1924		301t; 1x1-76/40
655	York City	1933		398t

Admiralty steel

22

1	Cascade	1918
2	Cloud	1918
3	Coldsnap	1918
4	Crescent Moon	1918
5	Eddy	1918
6	Glow	1918
7	Halo	1918
8	Harmattan	1918
9	Horizon	1918
10	Indian Summer	1918
11	Landfall	1918
12	Leeward	1918
13	Lunar Bow	1918
14	Mist	1918
15	Noontide	1918
16	Overfall	1918
17	Sheen	1918
18	Shower	1918
19	Seabreeze	1919
20	Flow	1920
21	Lasher	1920
22	Whirlpool	1920



200t, 28.4x5.7x2.3m, 1b, 1vte, 270hp, 9kts, ?p; 1x1-57/40, MS

Admiralty wooden	6	23	Fumarole	1919		175t, 28.7x6.1x2.2m, 1b, 1vte, 270hp, 9kts, ?p; 1x1-57/40, MS
		24	Red Sky	1918		
		25	Solstice	1918		
		26	Gloamin	1919		
		27	Refraction	1919		
		28	Rime	1919		
DF	58	29	Advisable	1930		115t
		30	Amalia	1917		139t
		31	Ascona	1930		138t
		32	Banshee	1929		115t
		33	Boy Alan	1914		109t
		34	Boy Philip	1930		128t
		35	Castle Bay	1918		108t
		36	Chestnut	1914		107t
		37	Cloverdale	1917		100t
		38	Comrades	1928		114t
		39	Daisy II	1908		100t
		40	Dorienta	1914		101t
		41	Eager	1912		102t
		42	Eileen Emma	1914		102t
		43	Faithful Star	1927		103t
		44	Feaco	1924		123t
		45	Feasible	1912		103t
		46	Gervais Rentoul	1917		100t
		47	Girl Gladys	1917		110t
		48	Gleam On	1919		100t
		49	Go Ahead!	1919		100t
		50	Grampian	1930		409t; 1x1-76/40
		51	Greenfly	1936		441t; 1x1-102/40
		52	Green Howard	1927		349t; 1x1-76/40
		53	Gregory	1930		355t; 1x1-76/40
		54	Grimsby Town	1934		422t
		55	Hilda Cooper	1928		127t
		56	Hosanna	1930		132t
		57	Industry	1907		100t
		58	Jeannies	1907		100t
		59	Kindred Star	1930		115t
		60	Lanner	1912		103t
		61	Lord Rodney	1928		104t
		62	Lord St. Vincent	1929		115t
		63	Lord Suffolk	1929		115t

			64	Margaret Hyde	1920		161t	
			65	Merbreeze	1931		117t	
			66	M. H. Buchan	1917		101t	
			67	Monarda	1916		109t	
			68	Ocean Breeze	1927		112t	
			69	Ocean Lifebuoy	1929		131t	
			70	Ocean Lux	1930		125t	
			71	Ocean Sunlight	1929		131t	
			72	Ocean Vim	1930		125t	
			73	Olivae	1915		107t	
			74	One Accord	1927		102t	
			75	Plough Boy	1912		102t	
			76	Plumer	1919		113t	
			77	Quiet Waters	1931		117t	
			78	Renascent	1926		100t	
			79	Rose Bud	1907		100t	
			80	Rose Hilda	1930		116t	
			81	Rose Valley	1918		100t	
			82	Silver Seas	1931		117t	
			83	Strive	1912		102t	
			84	Tritonia	1930		115t	
			85	Welcome Home	1925		104t	
			86	Willing Boys	1930		138t	
WL	Lake	6	1	Buttermere	1939	No picture	700t, 48.9x8.5x4.7m, 1b, 1vte, 1400hp, 13.8kts, 35p; 1x1-76/40, 1x2-12.7/62, MS	
			2	Ellesmere	1939			
			3	Grassmere	1939			
			4	Thirlmere	1939			
			5	Ullswater	1939			
			6	Windermere	1939			
	-		7	7	AN.2	1926		221t
				8	Gemas	1925		207t
				9	Jeram	1927		210t
				10	Rahman	1926		209t
				11	Roydur	1911		174t
				12	Sotra	1925		313t
				13	Trang	1912		205t
MSB	MMS51	1	1	MMS51	1938	No picture	22t, 18.3x4.0x0.9m, 2pe, 1500hp, 25kts, 9p; MS	

## NAVAL AVIATION (approximately, maximal number of delivered planes signed)

Deck planes F: 38 Sea Gladiator II intermediate, 60 Sea Gladiator II (delivery till 4/1940), 136 Roc I (delivery till early 1940); FB: 192 Skua II (delivery till 3/1940); TB: 992 Swordfish I (delivery till 1943)

Seaplanes

TB: part of Swordfish I (delivery till 1940); R: 24 Seagull V (amphibious), 555 Walrus I (amphibious, delivery till 1/1944), 66 Seafox I

© Ivan Gogin, 2010

[home](#)[World navies yesterday](#)[1940](#)

# UNITED STATES OF AMERICA 01 January 1940

*IN SERVICE: 16 battleships, 5 fleet aircraft carriers, 16 seaplane tenders, 18 heavy cruisers, 19 light cruisers, 212 destroyers, 100 submarines, 9 patrol ships (corvettes), 1 armed yacht, 6 gunboats, 5 river gunboats, 9 submarine chasers, 8 auxiliary patrol launches, 1 fast landing personnel transport, 10 minelayers, 26 minesweepers, 32 Coast Guard patrol ships, 56 Coast Guard patrol boats, 261 Coast Guard patrol launches*



## CAPITAL SHIPS

Wyoming	1	AG17	Wyoming (TS)	1912	A line drawing of the USS Wyoming (AG-17), a transport ship, shown from a starboard profile view. It features a single mainmast and a smaller foremast.	22000(1)-30610(2)t, 171.3x32.3x9.1m, 3b(1)-4b(2),4t, 21000(1)-28000(2)hp, 18(1)-21(2)kts, 400(1)-1242(2)p; 280belt(2), 119deck, 305turrets, 292CT(2); 3x2-305/50(1), 6x2-305/50(2), 16x1-127/51, 8x1-76/50, 3seaplanes(SOC, SON)
	2	BB33	Arkansas	1912		
New York	3	BB34	New York	1914	A line drawing of the USS New York (BB-34), a battleship, shown from a starboard profile view. It features two mainmasts and a foremast.	31924t, 174.7x32.3x9.2m, 6b, 2vte, 28100hp, 21kts, 1290p; 305belt, 356turrets, 114deck, 305CT; 5x2-356/45, 16x1-127/51, 8x1-76/50, 8x1-12.7/90, 3seaplanes (3 SOC+ SON); radar: CXZ(3), XAF(4)
	4	BB35	Texas	1914		
Nevada	5	BB36	Nevada	1916	A line drawing of the USS Nevada (BB-36), a battleship, shown from a starboard profile view. It features two mainmasts and a foremast.	31706t, 177.7x32.9x9.0m, 6b, 2t(5)-2vte(6), 25000hp, 20.5kts, 1374p; 343belt, 457-406turrets, 178deck, 406CT; 2x3-356/45, 2x2-356/45, 12x1-127/51, 8x1-127/25, 3seaplanes (3 SOC+ SON)
	6	BB37	Oklahoma	1916		
	7	BB38	Pennsylvania	1916		

BB	Pennsylvania	2	8	BB39	Arizona	1916		35929t, 185.34x32.4x9.2m, 6b, 4gt(7)-2t+2gt(4)(8), 33375hp, 21kts, 1052p; 343belt, 172deck, 457turrets, 406CT; 4x3-356/45, 12x1-127/51, 8x1-127/25, 3seaplanes (3 SOC+ SON)
			9	BB40	New Mexico	1918		
New Mexico		3	10	BB41	Mississippi	1917		36157t, 190.2x32.4x9.4m, 4b(9)-6b(10, 11), 4gt, 40000hp, 22kts, 1443p; 343belt, 210deck, 457turrets, 406CT; 4x3-356/50, 12x1-127/51, 8x1-127/25, 3seaplanes (3 SOC+ SON)
			11	BB42	Idaho	1919		
			12	BB43	Tennessee	1920		
Tennessee		2	13	BB44	California	1921		33190t, 190.2x29.7x9.2m, 8b, 2tg, 4em, 26800hp, 21kts, 1083p; 343belt, 127deck, 457turrets, 406CT; 4x3-356/50, 12x1-127/51, 8x1-127/25, 8x1-12.7/90, 2-533TT, 3seaplanes (3 SOC+ SON)
			14	BB45	Colorado	1923		
Colorado		3	15	BB46	Maryland	1921		33590t, 190.2x29.7x9.2m, 8b, 2tg, 4em, 28900hp, 21kts, 1080p; 343belt, 127deck, 457turrets, 406CT; 4x2-406/45, 12x1-127/51, 8x1-127/25, 8x1-12.7/90, 2-533TT, 3seaplanes (3 SOC+ SON)
			16	BB48	West Virginia	1923		

### AIRCRAFT CARRYING SHIPS

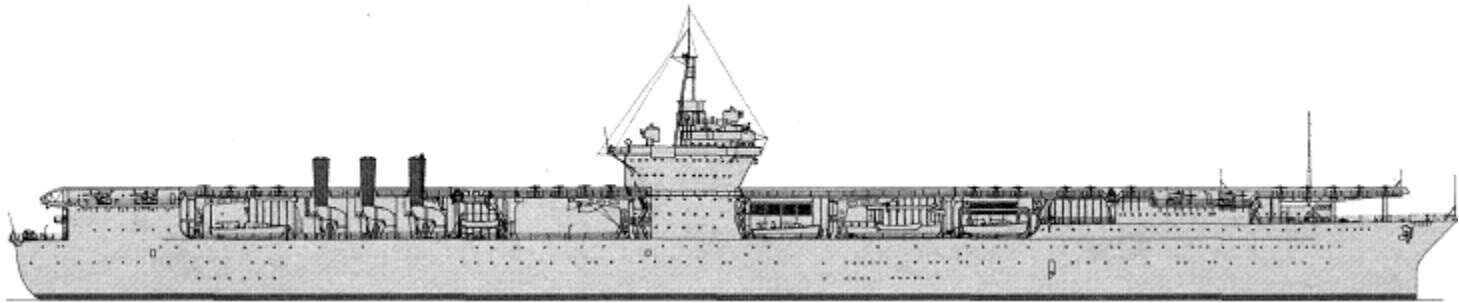
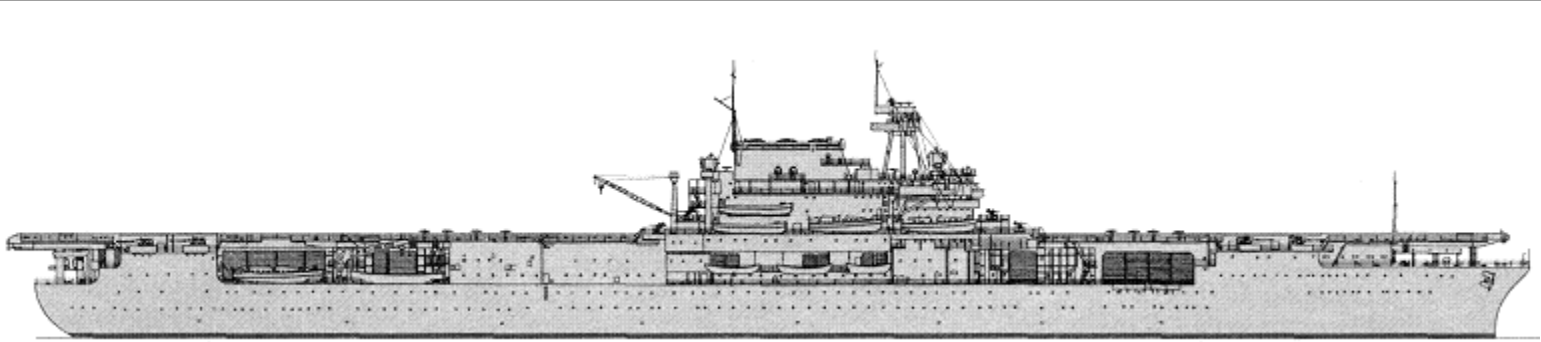
Lexington	2	1	CV2	Lexington	1927		43055t, 270.7x32.1x10.2m, 16b, 4tg, 4em, 180000hp, 33.2kts, 2327p; 178belt, 32deck, 51CT; 4x2-203/55, 12x1-127/25, 48x1-12.7/90, 63aircraft (18 F2F, 18 F3F, 18 BG, 23 SBU, 2 JF)
		2	CV3	Saratoga	1927		

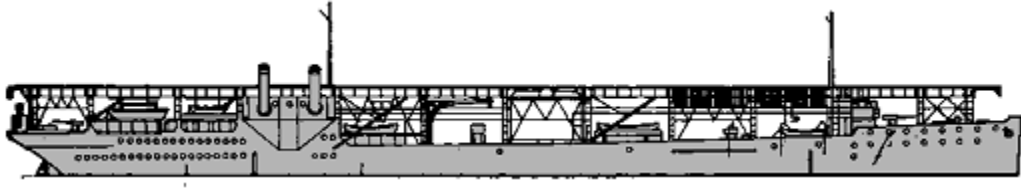
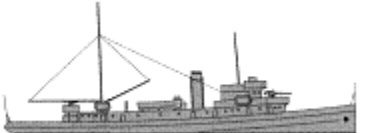

CV	Ranger	1	3	CV4	Ranger	1934		17577t, 234.4x33.4x6.8m, 6b, 2gt, 53500hp, 29.2kts, 1788p; 51belt, 25deck; 8x1-127/25, 40x1- 12.7/90, 76aircraft (30 F2F, 15 BG, 30 SBU)
	Yorktown	2	5	CV5 CV6	Yorktown Enterprise	1937 1938		25484t, 251.4x33.4x7.9m, 9b, 4gt, 120000hp, 32.5kts, 2175p; 102belt, 38deck, 102CT; 8x1- 127/38, 4x4-28/75, 24x1-12.7/90, 96aircraft (20 F3F, 23 SBC, 13 BT, 20 TBD)
AV	Wright	1	1	AV1	Wright	1921		11500t, 136.6x17.7x7.0m, 6b, 1t, 6000hp, 15kts, 228p; 2x1- 127/51, 2x1-76/50, 12seaplanes (2 SOC)
	Langley	1	2	AV3	Langley	1913		15150t, 165.3x19.9x6.3m, 3b, 2tg, 2em, 6500hp, 15.5kts, 468p; 4x1-127/51, 16seaplanes (2 SOC)
	Lapwing	9	3	AVP1	Lapwing	1918		1400t, 57.6x10.8x3.8m, 2b, 1vte, 1400hp, 13.5kts, 85p; 2x1- 76/50, 2seaplanes (really none)
			4	AVP2	Heron	1918		
			5	AVP3	Thrush	1919		
			6	AVP4	Avocet	1919		
			7	AVP5	Teal	1918		
8			AVP6	Pelican	1918			
Childs	5	12	AVP14	Childs	1920		1699t, 95.8x9.4x3.5m, 2b, 2gt, 13500hp, 25kts, 101p; 2x1- 102/50, 4x1- 12.7/90,	
		13	AVP15	Williamson	1920			
		14	AVP16	George E. Badger	1920			
		15	AVP17	Clemson	1919			

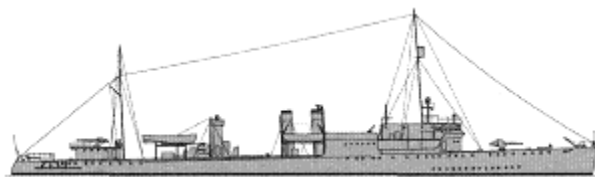
16	AVP18	Goldsborough	1920
----	-------	--------------	------

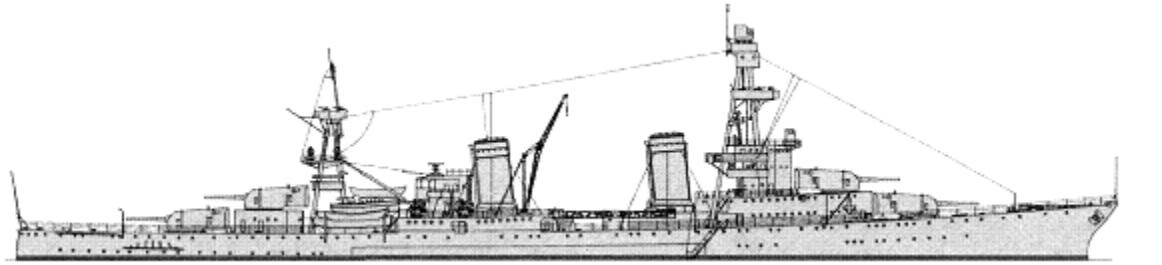
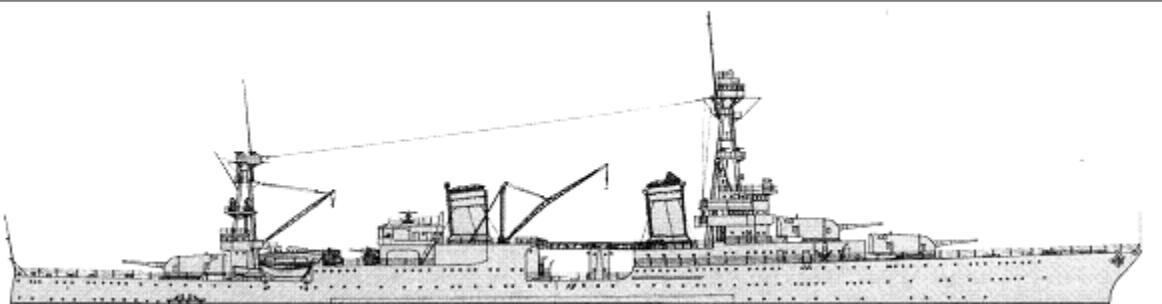
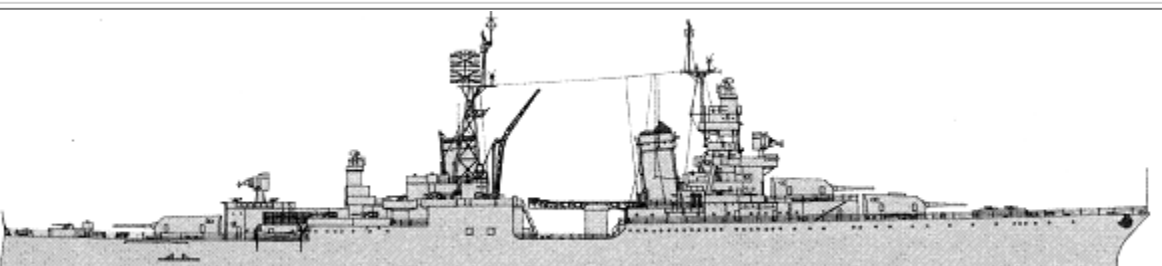
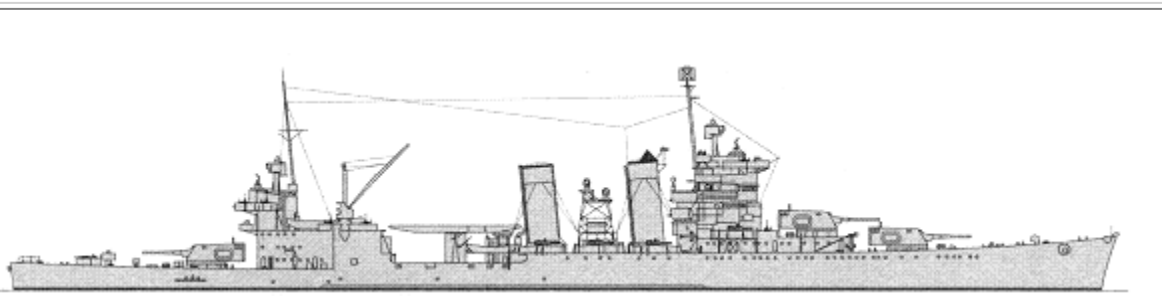

4seaplanes (really none)

### CRUISERS

Pensacola	2	1	CA24	Pensacola	1930		11512t, 178.5x19.9x5.9m, 8b, 4gt, 107000hp, 32.5kts, 631p; 102belt, 45deck, 64turrets, 32CT; (2x3+2x2)-203/55, 4x1-127/25, 8x1-12.7/90, 4seaplanes (4 SOC+ SON)
		2	CA25	Salt Lake City	1929		
Northampton	6	3	CA26	Northampton	1930		11420t, 183.0x20.1x5.9m, 8b, 4gt, 107000hp, 32.5kts, 617-748p; 95belt, 51deck, 64turrets, 32CT; 3x3-203/55, 8x1-127/25, 8x1-12.7/90, 4seaplanes (4 SOC+ SON)
		4	CA27	Chester	1930		
		5	CA28	Louisville	1931		
		6	CA29	Chicago	1931		
		7	CA30	Houston	1930		
CA Portland	2	8	CA31	Augusta	1931		12755t, 185.9x20.1x6.4m, 8b, 4gt, 107000hp, 32.5kts, 807-917p; 146belt, 64deck, 64turrets, 32CT; 3x3-203/55, 8x1-127/25, 8x1-12.7/90, 4seaplanes (4 SOC+ SON)
		9	CA33	Portland	1933		
New Orleans	7	10	CA35	Indianapolis	1932		12463t, 179.2x18.8x6.9m, 8b, 4gt, 107000hp, 32.7kts, 868p; 127belt, 57deck, 203turrets, 127CT; 3x3-203/55, 8x1-127/25, 8x1-12.7/90, 4seaplanes (4 SOC+ SON)
		11	CA32	New Orleans	1934		
		12	CA34	Astoria	1934		
		13	CA36	Minneapolis	1934		
		14	CA37	Tuscaloosa	1934		
		15	CA38	San Francisco	1934		
		16	CA39	Quincy	1936		
Wichita	1	17	CA44	Vincennes	1937		13015t, 185.4x18.8x7.2m, 8b, 4gt, 100000hp, 33kts, 929p; 152belt, 57deck, 203turrets, 152CT; 3x3-203/55, 8x1-127/38, 8x1-12.7/90, 4seaplanes (4 SOC+ SON)
		18	CA45	Wichita	1939		

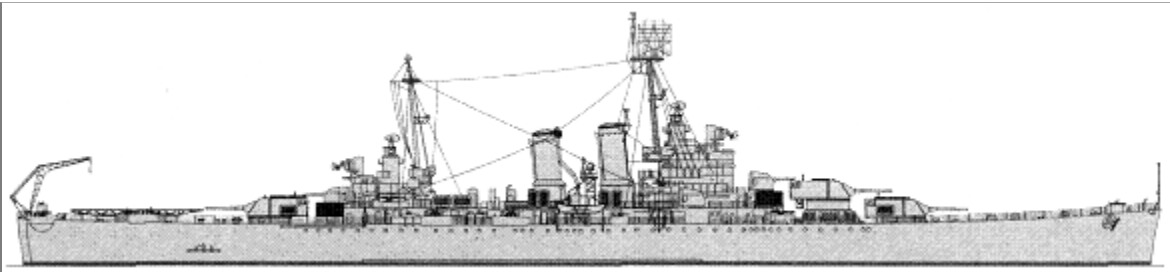
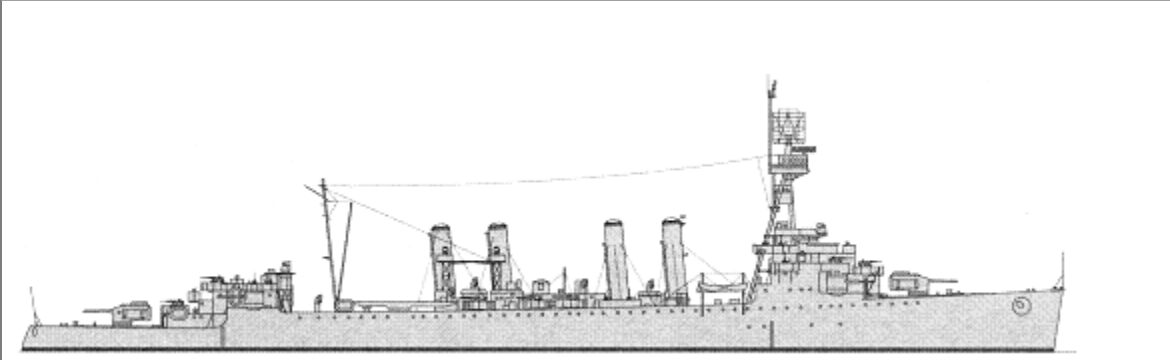
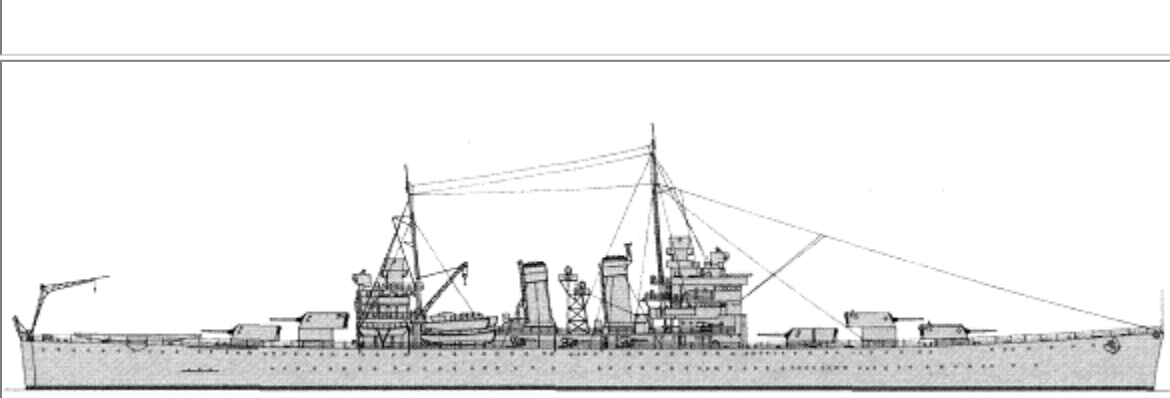

								
CL	Omaha	10	1	CL4	Omaha	1923		9508t, 169.4x16.9x4.1m, 12b, 4gt, 90000hp, 34kts, 458p; 76belt, 38deck, 32CT; (2x2+8x1)-152/53, 4x1-76/50, 2x3-533TT, 2seaplanes (2 SOC+ SON)
			2	CL5	Milwaukee	1923		
			3	CL6	Cincinnati	1924		
			4	CL7	Raleigh	1924		
			5	CL8	Detroit	1923		
			6	CL9	Richmond	1923		
			7	CL10	Concord	1923		
			8	CL11	Trenton	1924		
			9	CL12	Marblehead	1924		
			10	CL13	Memphis	1925		
	Brooklyn	9	11	CL40	Brooklyn	1938		12243-12700(40-43, 46-48)-13327(49, 50)t, 185.4x18.8x6.5-6.9(40-43, 46-48)-7.0-7.4(49, 50)m, 8b, 4gt, 100000hp, 32.5kts, 868p; 127belt, 51deck, 165turrets, 127CT; 5x3-152/47, 8x1-127/25(40-43, 46-48), 4x2-127/38(49, 50), 8x1-12.7/90, 4seaplanes (4 SOC+ SON)
			12	CL41	Philadelphia	1938		
			13	CL42	Savannah	1938		
			14	CL43	Nashville	1938		
			15	CL46	Phoenix	1939		
			16	CL47	Boise	1939		
			17	CL48	Honolulu	1938		
			18	CL49	St. Louis	1939		
			19	CL50	Helena	1939		

TORPEDO SHIPS

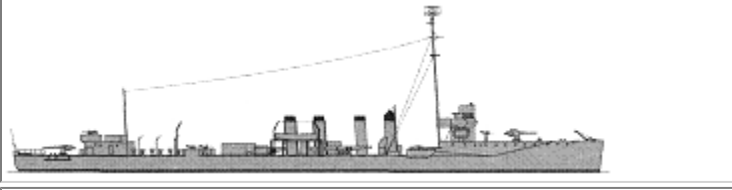
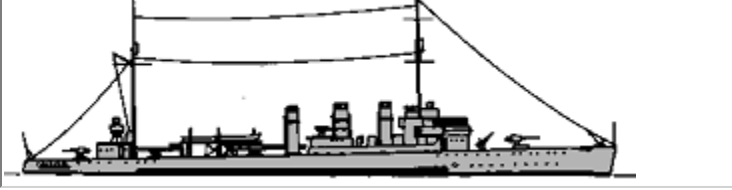
	Sampson	1	1	DD66	Allen	1917		1225t, 96.1x9.1x2.9m, 4b, 2t/1t(2)(63, 64)-2t/t(66), 17500hp, 29.5kts, 99p; 4x1-102/50, 2x1-12.7/90, 4x3-533TT, 1DCT, 2DCR
	Caldwell	3	2	DD70	Craven	1918		1187t, 96.2x9.3x2.7m, 4b, 2gt(70)-3t/1gt(3)(72, 73), 18500hp, 30kts, 100p; 4x1-102/50, 1x1-76/23, 2x1-12.7/90, 4x3-533TT, 1DCT, 2DCR
3			DD72	Conner	1918			
4			DD73	Stockton	1917			
			5	DD75	Wickes	1918		
			6	DD76	Philip	1918		
			7	DD78	Evans	1918		

8	DD79	Little	1918
9	DD81	Sigourney	1918
10	DD82	Gregory	1918
11	DD83	Stringham	1918
12	DD85	Colhoun	1918
13	DD88	Robinson	1918
14	DD89	Ringgold	1918
15	DD90	McKean	1919
16	DD93	Fairfax	1918
17	DD103	Schley	1918
18	DD106	Chew	1918
19	DD108	Williams	1919
20	DD109	Crane	1919
21	DD113	Rathburne	1918
22	DD114	Talbot	1918
23	DD115	Waters	1918
24	DD116	Dent	1918
25	DD117	Dorsey	1918
26	DD118	Lea	1918
27	DD125	Tattnall	1919
28	DD126	Badger	1919
29	DD127	Twiggs	1919
30	DD128	Babbitt	1919
31	DD130	Jacob Jones	1919
32	DD131	Buchanan	1919
33	DD132	Aaron Ward	1919
34	DD133	Hale	1919
35	DD134	Crowninshield	1919
36	DD135	Tillman	1920
37	DD137	Kilty	1918
38	DD138	Kennison	1919
39	DD139	Ward	1919
40	DD140	Claxton	1919
41	DD141	Hamilton	1919
42	DD142	Tarbell	1918
43	DD143	Yarnall	1918
44	DD144	Upshur	1918
45	DD145	Greer	1918
46	DD146	Elliot	1919
47	DD147	Roper	1919
48	DD148	Breckinridge	1919

Wickes 72

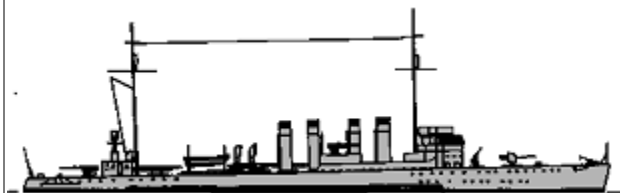

1247t, 95.8x9.4x2.8m, 4b, 2t/1t(2), 27000(75, 76, 78, 79, 81-83, 85, 88-90, 93, 103, 106, 108, 109, 113-118, 131-135, 137-156, 161, 162, 164, 167-170, 175, 178-185)-24900(125-128, 130)-26000(157-160)hp, 35kts, 114p; 4x1-102/50, 1x1-76/23, 2x1-12.7/90, 4x3-533TT, 1DCT, 2DCR

49	DD149	Barney	1919
50	DD150	Blakeley	1919
51	DD151	Biddle	1919
52	DD152	Du Pont	1919
53	DD153	Bernadou	1919
54	DD154	Ellis	1919
55	DD155	Cole	1919
56	DD156	J. Fred Talbot	1919
57	DD157	Dickerson	1919
58	DD158	Leary	1919
59	DD159	Schenk	1919
60	DD160	Herbert	1919
61	DD161	Palmer	1918
62	DD162	Thatcher	1919
63	DD164	Crosby	1919
64	DD167	Cowell	1919
65	DD168	Maddox	1919
66	DD169	Foote	1919
67	DD170	Kalk	1919
68	DD175	Mackenzie	1919
69	DD178	Hogan	1919
70	DD179	Howard	1920
71	DD180	Stansbury	1920
72	DD181	Hopewell	1919
73	DD182	Thomas	1919
74	DD183	Haraden	1919
75	DD184	Abbot	1919
76	DD185	Bagley	1919
77	DD187	Dahlgren	1920
78	DD190	Satterlee	1920
79	DD191	Mason	1920
80	DD193	Abel P. Upshur	1920
81	DD194	Hunt	1920
82	DD195	Welborn C. Wood	1921
83	DD197	Branch	1920
84	DD198	Herndon	1920
85	DD199	Dallas	1920
86	DD206	Chandler	1919

87	DD207	Southard	1919
88	DD208	Hovey	1919
89	DD209	Long	1919
90	DD210	Broome	1919
91	DD211	Alden	1919
92	DD213	Barker	1919
93	DD215	Borie	1920
94	DD216	John D. Edwards	1920
95	DD217	Whipple	1920
96	DD218	Parrott	1920
97	DD219	Edsall	1920
98	DD220	MacLeish	1920
99	DD221	Simpson	1920
100	DD222	Bulmer	1920
101	DD223	McCormick	1920
102	DD224	Stewart	1920
103	DD225	Pope	1920
104	DD226	Peary	1920
105	DD227	Pillsbury	1920
106	DD228	John D. Ford	1920
107	DD229	Truxtun	1921
108	DD230	Paul Jones	1921
109	DD231	Hatfield	1920
110	DD232	Brooks	1920
111	DD233	Gilmer	1920
112	DD234	Fox	1920
113	DD235	Kane	1920
114	DD236	Humphreys	1920
115	DD237	McFarland	1920
116	DD239	Overton	1920
117	DD240	Sturtevant	1920
118	DD242	King	1920
119	DD243	Sands	1920
120	DD245	Reuben James	1920
121	DD246	Bainbridge	1921
122	DD247	Goff	1921
123	DD248	Barry	1920
124	DD249	Hopkins	1921
125	DD250	Lawrence	1921

DD

Clemson 77





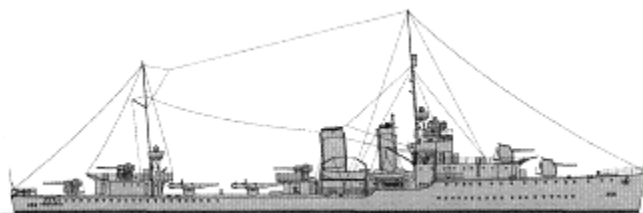

1308t, 95.8x9.4x3.0m, 4b, 2gt, 27000hp, 35kts, 114p; 4x1-102/50(187, 190, 191, 193-195, 197-199, 206, 207, 210, 211, 213, 215-230, 236, 237, 239, 240, 242, 243, 245-258, 260, 263-270, 273, 274, 336-344), 4x2-102/50(208, 209), 4x1-127/51(231-235), 1x1-76/23, 2x1-12.7/90, 4x3-533TT, 1DCT, 2DCR

126	DD251	Belknap	1919
127	DD252	McCook	1919
128	DD253	McCalla	1919
129	DD254	Rodgers	1919
130	DD255	Osmond Ingram	1919
131	DD256	Bancroft	1919
132	DD257	Welles	1919
133	DD258	Aulick	1919
134	DD260	Gillis	1919
135	DD263	Laub	1919
136	DD264	McLanahan	1919
137	DD265	Edwards	1919
138	DD266	Greene	1919
139	DD267	Ballard	1919
140	DD268	Shubrick	1919
141	DD269	Bailey	1919
142	DD270	Thornton	1919
143	DD273	Swasey	1919
144	DD274	Meade	1919
145	DD336	Litchfield	1920
146	DD337	Zane	1921
147	DD338	Wasmuth	1921
148	DD339	Trever	1922
149	DD340	Perry	1922
150	DD341	Decatur	1922
151	DD342	Hulbert	1920
152	DD343	Noa	1921
153	DD344	William B. Preston	1920
154	DD348	Farragut	1934
155	DD349	Dewey	1934
156	DD350	Hull	1935
157	DD351	MacDonough	1935
158	DD352	Worden	1935
159	DD353	Dale	1935
160	DD354	Monaghan	1935
161	DD355	Aylwin	1935
162	DD356	Porter	1936
163	DD357	Selfridge	1936
164	DD358	McDougal	1936

Farragut 8

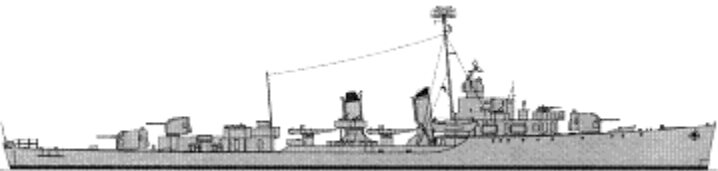



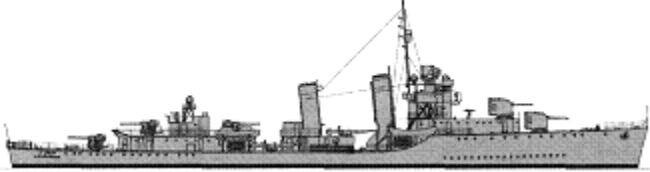

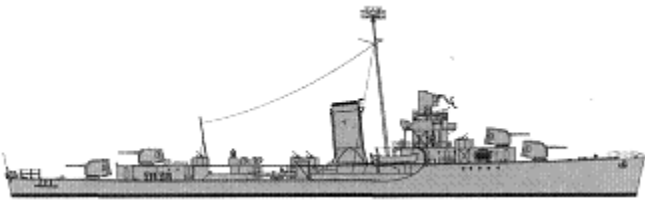
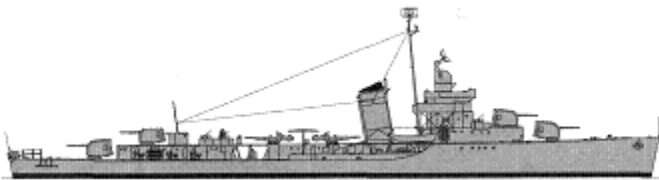
2064t, 104.0x10.4x3.5m, 4b, 2gt, 42800hp, 36.5kts, 160p; 5x1-127/38, 4x1-12.7/90, 2x4-533TT

Porter	8						2597t, 116.2x11.3x4.0m, 4b, 2gt, 50000hp, 37kts, 194p; 4x2-127/38, 2x4-28/75, 2x1-12.7/90, 2x4-533TT, 2DCR
		165	DD359	Winslow	1937		
		166	DD360	Phelps	1936		
		167	DD361	Clark	1936		
		168	DD362	Moffett	1936		
		169	DD363	Balch	1936		
Mahan	16	170	DD364	Mahan	1936		2103t, 104.0x10.7x3.8m, 4b, 2gt, 49000hp, 36.5kts, 158p; 5x1-127/38, 4x1-12.7/90, 3x4-533TT, 2DCT
		171	DD365	Cummings	1936		
		172	DD366	Drayton	1936		
		173	DD367	Lamson	1936		
		174	DD368	Flusser	1936		
		175	DD369	Reid	1936		
		176	DD370	Case	1936		
		177	DD371	Conyngham	1936		
		178	DD372	Cassin	1936		
		179	DD373	Shaw	1936		
		180	DD374	Tucker	1936		
		181	DD375	Downes	1937		
		182	DD376	Cushing	1936		
		183	DD377	Perkins	1936		
		184	DD378	Smith	1936		
		185	DD379	Preston	1936		
Gridley	4	186	DD380	Gridley	1937		2219t, 103.9x10.7x3.9m, 4b, 2gt, 50000hp, 158p; 4x1-127/38, 4x1-12.7/90, 4x4-533TT, 2DCR
		187	DD382	Craven	1937		
		188	DD400	McCall	1938		
		189	DD401	Maury	1938		
Somers	5	190	DD381	Somers	1937		2767t, 116.1x11.3x3.8m, 4b, 2gt, 52000hp, 37kts, 294p; 4x2-127/38, 2x4-28/75, 2x1-12.7/90, 3x4-533TT, 2DCR
		191	DD383	Warrington	1938		
		192	DD394	Sampson	1938		
		193	DD395	Davis	1938		
		194	DD396	Jouett	1939		
Dunlap	2	195	DD384	Dunlap	1937		2103t, 104.0x10.7x3.8m, 4b, 2gt, 49000hp, 36.5kts, 158p; 5x1-127/38, 4x1-12.7/90, 3x4-533TT, 2DCT
		196	DD385	Fanning	1937		
		197	DD397	Benham	1939		
		198	DD398	Ellet	1939		
		199	DD399	Lang	1939		
		200	DD402	Mayrant	1939		





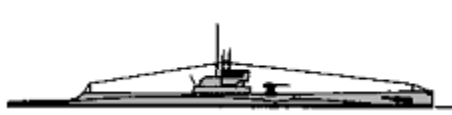





Benham	10	201	DD403	Trippe	1939		2250t, 103.9x10.8x3.9m, 3b, 2gt, 50000hp, 38.5kts, 184p; 4x1-127/38, 4x1-12.7/90, 4x4-533TT, 2DCR
		202	DD404	Rhind	1939		
		203	DD405	Rowan	1939		
		204	DD406	Stack	1939		
		205	DD407	Sterett	1939		
		206	DD408	Wilson	1939		
Sims	6	207	DD409	Sims	1939		2313t, 106.2x11.0x3.9m, 3b, 2gt, 50000hp, 35kts, 192p; 5x1-127/38, 4x1-12.7/90, 3x4-533TT(409-413), 2x4-533TT(414), 2DCR
		208	DD410	Hughes	1939		
		209	DD411	Anderson	1939		
		210	DD412	Hammann	1939		
		211	DD413	Mustin	1939		
		212	DD414	Russell	1939		

### SUBMARINES

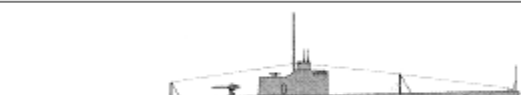
O	8	1	SS63	O2	1918		521/629t, 52.5x5.5x4.4m, 2d/em, 600/550hp, 13/11kts, 25p, 60m; 1x1-76/23, 4-450TT
		2	SS64	O3	1918		
		3	SS65	O4	1918		
		4	SS67	O6	1918		
		5	SS68	O7	1918		
		6	SS69	O8	1918		
		7	SS70	O9	1918		
		8	SS71	O10	1918		
R	19	9	SS78	R1	1918		569/680t, 56.8x5.5x4.4m, 2d/em, 1200/940hp, 13.5/11kts, 29p, 60m; 1x1-76/50 or 1x1-12.7/90, 4-533TT
		10	SS79	R2	1919		
		11	SS80	R3	1919		
		12	SS81	R4	1919		
		13	SS82	R5	1919		
		14	SS83	R6	1919		
		15	SS84	R7	1919		
		16	SS86	R9	1919		
		17	SS87	R10	1919		
		18	SS88	R11	1919		
		19	SS89	R12	1919		
		20	SS90	R13	1919		
		21	SS91	R14	1919		
		22	SS92	R15	1918		
		23	SS93	R16	1918		
		24	SS94	R17	1918		

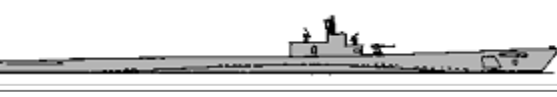
			25	SS95	R18	1918		
			26	SS96	R19	1918		
			27	SS97	R20	1918		
SI	24		28	SS105	S1	1920		854/1062t, 66.9x6.3x4.8m, 2d/em, 1200/1500hp, 14/11kts, 38p, 60m; 1x1-102/50, 1x1-12.7/90, 4-533TT
			29	SS123	S18	1924		
			30	SS125	S20	1922		
			31	SS126	S21	1921		
			32	SS127	S22	1924		
			33	SS128	S23	1923		
			34	SS129	S24	1923		
			35	SS130	S25	1923		
			36	SS131	S26	1923		
			37	SS132	S27	1924		
			38	SS133	S28	1923		
			39	SS134	S29	1924		
			40	SS135	S30	1920		
			41	SS136	S31	1922		
			42	SS137	S32	1922		
			43	SS138	S33	1922		
			44	SS139	S34	1922		
			45	SS140	S35	1922		
			46	SS141	S36	1923		
			47	SS142	S37	1923		
			48	SS143	S38	1923		
			49	SS144	S39	1923		
			50	SS145	S40	1923		
			51	SS146	S41	1924		
SS	SIII	7	52	SS116	S11	1923		876/1092t, 70.4x6.7x4.0m, 2d/em, 2000/1200hp, 15/11kts, 38p, 60m; 1x1-102/50, 1x1-12.7/90, 5-533TT(116-118), 4-533TT(119-122)
			53	SS117	S12	1923		
			54	SS118	S13	1923		
			55	SS119	S14	1921		
			56	SS120	S15	1921		
			57	SS121	S16	1920		
			58	SS122	S17	1921		
SIV	6	59	SS153	S42	1924		906/1126t, 68.7x6.3x4.9m, 2d/em, 1200/1200hp, 14.5/11kts, 38p, 60m; 1x1-102/50, 1x1-12.7/90, 4-533TT	
		60	SS154	S43	1924			
		61	SS155	S44	1925			
		62	SS156	S45	1925			
		63	SS157	S46	1925			
		64	SS158	S47	1925			

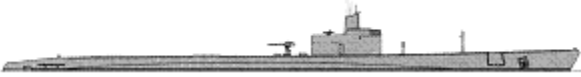

SV	1	65	SS159	S48	1922		903/1230t, 73.2x6.6x4.1m, 2d/em, 1800/1500hp, 14.5/11kts, 38p, 60m; 1x1-102/50, 1x1-12.7/90, 5-533TT
V1	3	66	SS163	Barracuda	1924		2119/2506t, 102.0x8.4x4.6m, 2d+2dg/em(2), 6200/2400hp, 18.7/9kts, 85p, 60m; 1x1-76/50, 6-533TT
		67	SS164	Bass	1925		
		68	SS165	Bonita	1926		
V4	1	69	SS166	Argonaut	1928		2878/4045t, 116.1x10.3x4.9m, 2d+2dg/em(2), 3175/2200hp, 13.6/7.4kts, 86p, 95m; 2x1-152/53, 4-533TT, 60mines
V5	2	70	SS167	Narwhal	1930		2987/3960t, 113.1x10.1x5.2m, 2d+2dg/2em(2), 5633/1600hp, 17.4/8kts, 89p, 100m; 2x1-152/53, 2x1-12.7/90, 6-533TT
		71	SS168	Nautilus	1930		
Dolphin	1	72	SS169	Dolphin	1932		1688/2215t, 97.3x8.5x4.0m, 2d+2dg/2em(2), 3500/1750hp, 17/8kts, 63p, 75m; 1x1-76/50, 2x1-12.7/90, 6-533TT
Cachalot	2	73	SS170	Cachalot	1933		1120/1650t, 82.9x7.5x4.3m, 2d/em, 3100/1600hp, 17/8kts, 51p, 75m; 1x1-76/50, 3x1-12.7/90, 6-533TT
		74	SS171	Cuttlefish	1934		
Porpoise	2	75	SS172	Porpoise	1935		1316/1934t, 91.8x7.6x4.3m, 4dg, 2em, 4300/2085hp, 19/10kts, 54p, 75m; 1x1-76/50, 2x1-12.7/90, 6-533TT
		76	SS173	Pike	1935		
Shark	2	77	SS174	Shark	1936		1315/1968t, 90.8x7.6x4.6m, 4dg, 2em, 4300/2085hp, 19.5/8kts, 54p, 75m; 1x1-76/50, 2x1-12.7/90, 6-533TT
		78	SS175	Tarpon	1936		
Perch	6	79	SS176	Perch	1936		1330/1997t, 91.6x7.7x4.6m, 4dg, 2em, 4300/2366hp, 19.2/8kts, 54p, 75m; 1x1-76/50, 2x1-12.7/90, 6-533TT
		80	SS177	Pickerel	1937		
		81	SS178	Permit	1937		
		82	SS179	Plunger	1936		
		83	SS180	Pollack	1937		
		84	SS181	Pompano	1937		
Salmon	6	85	SS182	Salmon	1938		1449/2210t, 93.9x8.0x4.8m, 4d/2em, 5500/2660hp, 21/9kts, 59p, 75m; 1x1-76/50, 2x1-12.7/90, 8-533TT
		86	SS183	Seal	1938		
		87	SS184	Skipjack	1938		
		88	SS185	Snapper	1937		
		89	SS186	Stingray	1938		
		90	SS187	Sturgeon	1938		
Sargo	5	91	SS188	Sargo	1939		1450/2198t, 94.6x8.2x5.1m, 4d/em, 5500/2740hp, 20/8.7kts, 59p, 75m; 1x1-76/50, 2x1-12.7/90, 8-533TT
		92	SS189	Saury	1939		
		93	SS190	Spearfish	1939		
		94	SS191	Sculpin	1939		
		95	SS192	Squalus	1939		
		96	SS193	Swordfish	1939		
		97	SS194	Seadragon	1939		

Swordfish	5	98	SS195	Sealion	1939		1450/2198t, 94.6x8.2x5.1m, 4dg, 2em, 5200/2740hp, 20/8.7kts, 59p, 75m; 1x1-76/50, 2x1-12.7/90, 8-533TT
		99	SS196	Searaven	1939		
		100	SS197	Seawolf	1939		

## ESCORTS

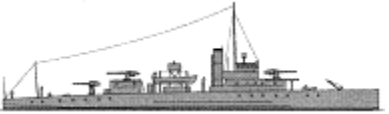
PC	Eagle	9	1	PE19	-	1919		615t, 61.2x10.1x2.6m, 2b, 1gt, 2500hp, 18.3kts, 61p; 2x1-102/50, 1x1-76/50, 1DCT
			2	PE27	-	1919		
			3	PE32	-	1919		
			4	PE38	-	1919		
			5	PE48	-	1919		
			6	PE55	-	1919		
			7	PE56	-	1919		
			8	PE57	-	1919		
			9	PE58	-	1919		
PY	-	1	1	PY10	Isabel	1917	710t	

## OTHER FIGHTING SHIPS

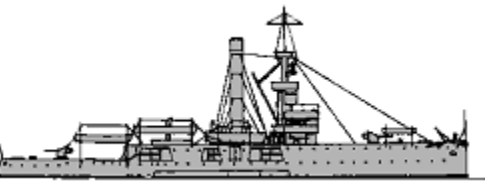
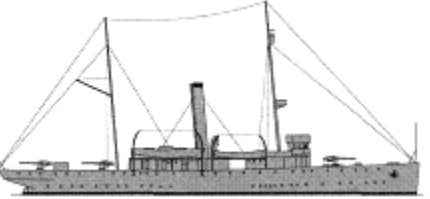
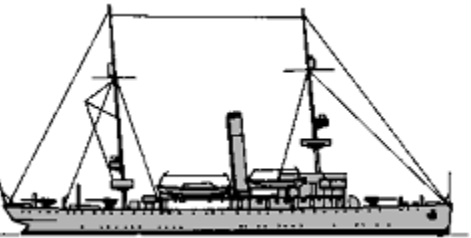
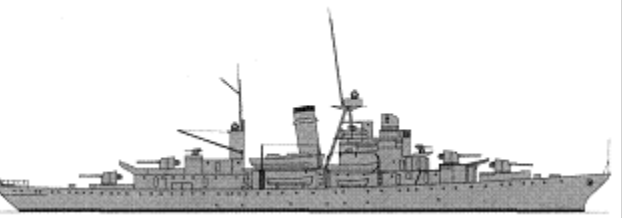
PG	Wilmington	1	1	PG8	Wilmington	1897		1689t, 76.4x12.5x2.7m, 6b, 2vte, 15kts, 183-199p; 25belt, 38deck; 8x1-102/40
	Sacramento	1	2	PG19	Sacramento	1914		1592t, 69.0x12.5x3.5m, 2b, 1vte, 12.5kts, 163p; 3x1-102/50
	Asheville	2	3	PG21	Asheville	1920		1760t, 73.5x12.6x3.4m, 3b, 1gt, 850hp, 12kts, 159p; 3x1-102/50
			4	PG22	Tulsa	1923		
Erie	2	5	PG50	Erie	1936		2800t, 100.1x12.6x3.5m, 2b, 2gt, 6200hp, 20kts, 236p; 89belt, 32deck, 102CT; 4x1-152/47, 4x4-28/75, 1seaplane (1 SOC)	
		6	PG51	Charleston	1936			

	Guam	2	1	PR3	Guam	1927		395t, 48.6x8.3x1.6m, 2b, 2vte, 1950hp, 14.5kts, 70p; 2x1-76/50
			2	PR4	Tutuila	1928		
PR	Panay	1	3	PR6	Oahu	1928		474t, 58.2x8.6x1.6m, 2b, 2vte, 2250hp, 15kts, 70p; 2x1-76/50
	Luzon	2	4	PR7	Luzon	1928		620t, 64.2x9.5x1.7m, 2b, 2vte, 3150hp, 16kts, 70p; 2x1-76/50
			5	PR8	Mindanao	1928		

### COASTAL FORCES

PS	SC1	9	1 - 9	SC64, 102, 185, 330, 412, 431, 432, 437, 440	-	1917 - 1919		85t, 33.5x4.5x1.7m, 3pe, 660hp, 18kts, 27p; 1x1-76/23, 1DCT
YP	Corwin	8	1	YP41	-	1926	No picture	210t, 30.4x7.0x1.4m, 2d, 300hp, 12kts, 15p; 1x1-76/23
			2	YP42	-	1926		
			3	YP56	-	1926		
			4	YP61	-	1925		
			5	YP62	-	1925		
			6	YP63	-	1925		
			7	YP64	-	1925		
			8	YP69	-	1926		



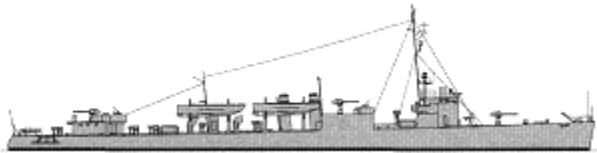

### AMPHIBIOUS

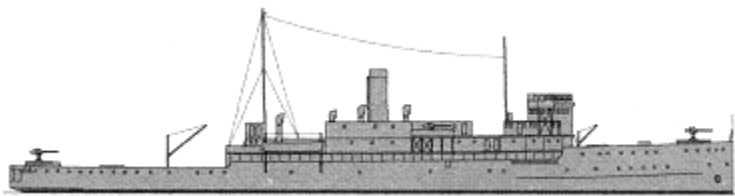
LPR	Caldwell	1	1	AG28	Manley	1917		1793t, 96.2x9.3x3.8m, 2b, 2gt, 13000hp, 24kts, 101p; 4x1-102/50, 4x1-12.7/90, 4DCT, 2DCR; 4 LCPL, 144troops
-----	----------	---	---	------	--------	------	--	---

### MINE WARFARE

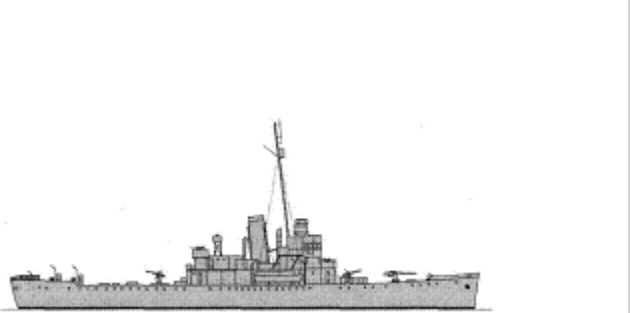
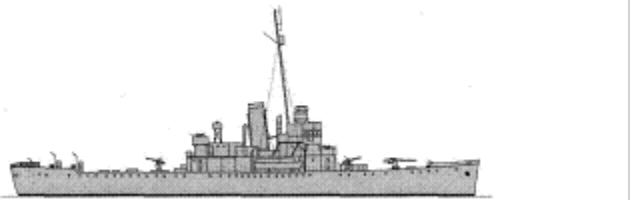
	Aroostook	2	1	CM3	Aroostook	1907		4200t, 120.4x15.9x4.9m, 8b, 2vte, 7000hp, 20kts, 314p; 1x1-127/51, 2x1-76/50, 300mines
			2	CM4	Oglala	1907		
ML	Stribling	4	3	DM15	Gamble	1918		1247t, 95.8x9.4x2.8m, 4b, 2t/1t(2), 27000hp, 35kts, 114p; 4x1-102/50, 1x1-76/23, 2x1-12.7/90, 2DCR,
			4	DM16	Ramsay	1919		

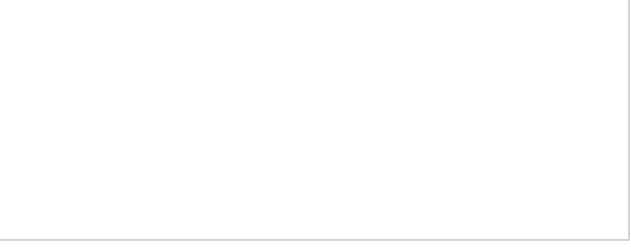

WPS	Treasury	7	3	WPG27	Tallapoosa	1915		2660t, 99.7x12.5x3.8m, 2b, 2gt, 5250hp, 19kts, 123p; 2x1-127/51, 2x1-57/40, 1x1-37/40, 1seaplane (1 J2F)
			4	WPG31	Bibb	1937		
			5	WPG32	Campbell	1936		
			6	WPG33	Duane	1936		
			7	WPG34	Hamilton	1937		
			8	WPG35	Ingham	1936		
			9	WPG36	Spencer	1937		
			10	WPG37	Taney	1936		
	Haida	4	11	WPG45	Haida	1921		1955t, 73.2x11.9x5.0m, 2b, 1tg, 1em, 2600hp, 15kts, 122p; 2x1-127/51, 1x1-76/50(46), 2x1-57/40(45, 47, 48), 2x1-57/40(46), 1x1-37/40(45, 47, 48)
			12	WPG46	Modoc	1922		
			13	WPG47	Mojave	1921		
			14	WPG48	Tampa	1921		
	Lake	10	15	WPG45	Chelan	1928		2075t, 76.2x12.8x3.9m, 2b, 1tg, 1em, 3350hp, 17kts, 97p; 1x1-127/51, 1x1-76/50, 2x1-57/40
			16	WPG46	Pontchartrain	1928		
			17	WPG47	Tahoe	1928		
			18	WPG48	Champlain	1929		
			19	WPG49	Mendota	1929		
			20	WPG50	Itasca	1930		
			21	WPG51	Sebago	1930		
			22	WPG52	Saranac	1930		
			23	WPG53	Shoshone	1931		
			24	WPG54	Cayuga	1932		
	Northland	1	25	WPG49	Northland	1927		2150t, 66.0x11.9x4.2m, 2dg, 1em, 1000hp, 11.5kts, 107p; 2x1-57/40, 1x1-37/40, 1seaplane (1 J2F)
	Miami	1	26	WPG53	Unalga	1912		1181t, 57.9x9.9x4.3m, 1vte, 1300hp, 13kts; 2x1-102/50, 2x1-76/50, 2DCR
Algonquin	6	27	WPG75	Algonquin	1934		1005t, 50.3x11.0x3.7m, 2b, 1gt, 1500hp, 12.5kts, 61p; 2x1-76/50	
		28	WPG76	Comanche	1934			
		29	WPG77	Escanaba	1932			
		30	WPG78	Mohawk	1935			
		31	WPG79	Onondaga	1934			
		32	WPG80	Tahoma	1934			
Corwin	3	1		Forward	1925		210t, 30.4x7.0x1.4m, 2d, 300hp, 12kts, 15p; 1x1-76/23	
		2		Nansemond	1926			
		3		Petrel	1926			
		4	WPC125	Active	1927			
		5	WPC126	Agassiz	1927			
		6	WPC127	Alert	1927			
		7	WPV128	Antietam	1927			
		8	WPC129	Bonham	1927			

WPC	Active	32	9	WPC130	Boutwell	1927		289t, 38.1x7.1x2.1m, 2d, 600hp, 13.3kts, 38p; 1x1-76/23				
			10	WPC131	Cahoone	1927						
			11	WPC132	Cartigan	1927						
			12	WPC133	Montgomery	1927						
			13	WPC134	Crawford	1927						
			14	WPC135	Diligence	1927						
			15	WPC136	Dix	1927						
			16	WPC137	Ewing	1927						
			17	WPC138	Faunce	1927						
			18	WPC139	Frederick Lee	1927						
			19	WPC140	General Greene	1927						
			20	WPC141	Harriet Lane	1927						
			21	WPC142	Jackson	1927						
			22	WPC143	Kimball	1927						
			23	WPC144	Legare	1927						
			24	WPC145	Marion	1927						
			25	WPC146	McLane	1927						
			26	WPC147	Morris	1927						
			27	WPC148	Nemaha	1927						
			28	WPC149	Pulaski	1927						
			29	WPC150	Reliance	1927						
			30	WPC151	Rush	1927						
			31	WPC152	Tiger	1927						
			32	WPC153	Travis	1927						
			33	WPC154	Vigilant	1927						
			34	WPC155	Woodbury	1927						
			35	WPC156	Yeaton	1927						
			Argo	17	36	WPC100			Argo	1933	No picture	370t, 50.3x7.2x2.3m, 2d, 1340hp, 16kts, 50p; 1x1-76/23, 1x1-37/40
					37	WPC101			Ariadne	1934		
					38	WPC102			Atalanta	1934		
					39	WPC103			Aurora	1931		
					40	WPC104			Calypso	1932		
					41	WPC105			Cyane	1934		
					42	WPC106			Daphne	1932		
					43	WPC107			Dione	1934		
44	WPC108	Galatea			1933							
45	WPC109	Hermes			1932							
46	WPC110	Icarus			1932							
47	WPC111	Nemesis			1934							
48	WPC112	Nike			1934							
49	WPC113	Pandora	1934									

			50	WPC114	Perseus	1932		
			51	WPC115	Thetis	1931		
			52	WPC116	Triton	1934		
	SC1	4	53 - 56	WSC229, 231, 238, 258	Boone, Blaze, Bowstring, Belleville	1917 - 1918		85t, 33.5x4.5x1.7m, 3pe, 660hp, 18kts, 27p; 1x1-76/23, 1DCT
WYP	CG100	196	5 - 200	CG100 - 302	-	1924 - 1926	No picture	37t, 22.9x4.2x1.2m, 1pe, 400hp, 13kts; 1x1-37/43
	CG400	6	201 - 206	CG400 - 405	-	1931	No picture	43t, 24.1x4.4x1.2m, 2pe, 1200hp, 21kts; 1x1-37/43
	CG2385	42	207 - 248	CG2385 - 2399, 4300 - 4326	-	1931 - 1937	No picture	11.6m
	CG406	9	249 - 257	CG406 - 414	-	1937	No picture	52t, 24.7x4.8x1.2m, 2pe, 1600hp, 25kts; 1x1-37/43, 1DCR
	CG440	2	258, 259	CG440, 441	-	1937	No picture	21.9m; 1x1-37/43, 1DCR
	CG442	2	260, 261	CG442, 443	-	1937	No picture	19.8m; 1x1-37/43, 1DCR

#### NAVAL AVIATION *(approximately, maximal number of delivered planes signed)*

Deck planes	F: 54 F2F-1, 54 F3F-1, 81 F3F-2, 27 F3F-3, 11 F2A-1 Buffalo (delivery till 1940); TB: 61 BG-1, 130 TBD-1 Devastator; DB: 84 SBU-1, 40 SBU-2, 83 SBC-3 Helldiver, 174 SBC-4 Helldiver (delivery till 4/1941), 54 SB2U-1 Vindicator, 58 SB2U-2 Vindicator (delivery till 1940), 54 BT-1; R: some J2F-1 Duck
Seaplanes	R: 87 O3U-1, 76 O3U-3, 32 O3U-6, 27 JF-1(amphibious), 15 JF-2, 29 J2F-1 Duck (amphibious, inc carrier planes), 30 J2F-2 Duck (amphibious), 20 J2F-3 Duck (amphibious), 32 J2F-4 Duck (amphibious, delivery till 1940), 135 SOC-1 Seagull, 83 SOC-3 Seagull, 44 SON-1 Seagull

[home](#)

[World navies yesterday](#)

[1940](#)

## Uruguay 01 January 1940

### TORPEDO SHIPS

PGT	Uruguay	1	1	Uruguay	1910		1400t, 85.0ppx9.4x3.6m, 4b,2vte, 5700hp, 23kts, 125p; steel: 17deck; 2x1-120/45, 4x1-76/40, 6x1-37/43, 2x1-450TT
-----	---------	---	---	---------	------	--	--

### ESCORTS

PC	Paysandú	3	1	Paysandú	1936		180t, 41.9x5.8x1.7m, 2d, 1000hp, 17kts, 51p; 2x1-76/40, 2x1-47/40
			2	Salto	1936		
			3	Río Negro	1936		

© Ivan Gogin, 2011-15



[home](#)[World navies yesterday](#)[1940](#)

## Venezuela 01 January 1940

### OTHER FIGHTING SHIPS

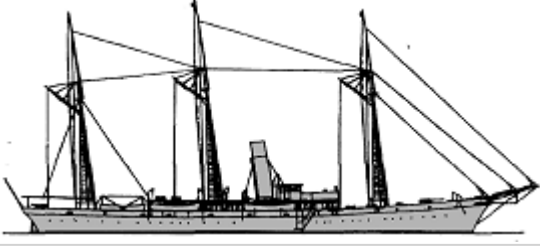
PG	Miranda	1	1	Miranda	1895	No picture	200t, 41.5x5.8x2.5m, 1b,1vte, 315hp, 10kts, 55p; 4x1-57/43	
	General Soubllette	2	2	General Soubllette	1926		850t, 62.2x8.7x2.6m, 2b,2vte, 1500hp, 15kts, 66p; 2x1-102/35, 1x1-76/40	
			3	General Urdaneta	1926			
APG -		2	1	General Salóm	1884			
			2	Aragua		154t		

© Ivan Gogin, 2011-15

[home](#)[World navies yesterday](#)[1940](#)

## Yugoslavia 01 January 1940

*IN SERVICE: 1 seaplane tender, 1 protected cruiser, 4 destroyers, 6 torpedo boats, 4 submarines, 4 river monitors, 10 motor torpedo boats, 2 river patrol launches, 12 minesweepers*

*IN CONSTRUCTION: 1 destroyer, 1 patrol ship*

*IN SERVICE*

### AIRCRAFT CARRYING SHIPS

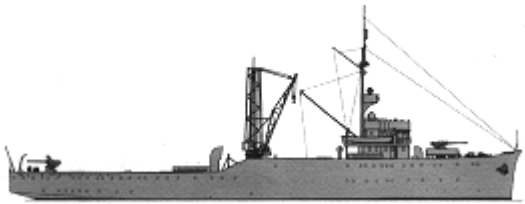

AV	Zmaj	1	1	Zmaj	1930		2084t, 83.0x12.7x3.5m, 2d, 3260hp, 15kts, 145p; 2x1-83/55, 2x2-40/6, 2seaplanes (DH.60)
----	------	---	---	------	------	---	---

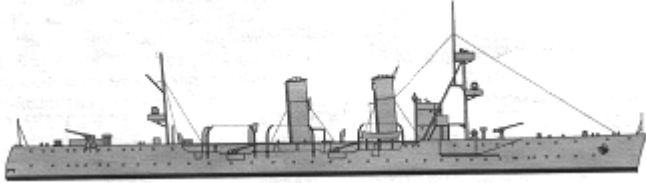
### CRUISERS

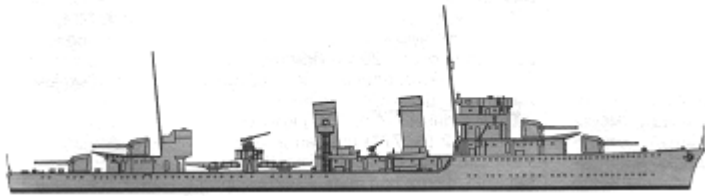

CL	Dalmacija	1	1	Dalmacija	1900		2953t, 105.0x12.2x5.2m, 8b,2vte, 8110hp, 16kts, 300p; 25deck, 50slopes, 80CT; 6x1-83/55, 4x1-47/44, 2x1-15
----	-----------	---	---	-----------	------	--	--

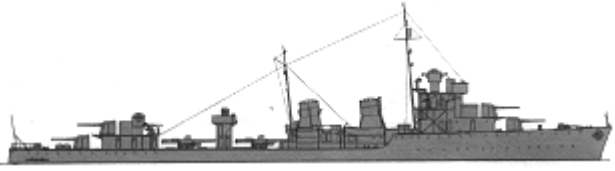
### TORPEDO SHIPS

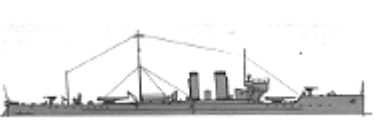

DD	Dubrovnik	1	1	Dubrovnik	1932		2884t, 113.2x10.7x3.6m, 3b,2gt, 42000hp, 37kts, 240p; 4x1-140/56, 1x2-83/55, (2x2+2x1)-40/67, 2x1-15, 2x3-533TT, 40m, 2DCT, 2DCR
----	-----------	---	---	-----------	------	--	--

	Beograd	3	2	Beograd	1939		1655t, 98.0x9.5x3.2m, 3b,2gt, 44000hp, 38kts, 145p; 4x1-120/46, 2x2-40/56, 2x1-15, 2x3-550TT, 30m, 1DCR
			3	Ljubljana	1939		
			4	Zagreb	1939		
TB	T1	2	1	T1	1914		320t, 58.2x5.7x1.5m, 2b,2t, 5000hp, 28kts, 52p; 2x1-66/50, 2x2-450TT
			2	T3	1914		
TB	T5	4	3	T5	1915		330t, 58.8x5.8x1.5m, 2b,2t, 5000hp, 28kts, 52p; 2x1-66/50, 2x2-450TT
			4	T6	1916		
			5	T7	1916		
			6	T8	1916		

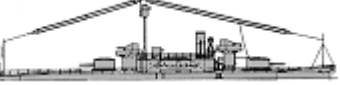

## SUBMARINES

SS	Hrabri	2	1	Hrabri	1928		975/1164t, 72.1x7.3x4.0m, 2d/em, 2400/1600hp, 15.7/10kts, 47p, 50m; 2x1-102/40, 1x1-13.2, 6-533TT
			2	Nebojša	1928		
SS	Smeli	2	3	Smeli	1929		655/822t, 69.1x5.4x3.8m, 2d/em, 1480/1100hp, 14.5/9.2kts, 45p, 80m; 1x1-100/40, 1x1-40/67, 6-550TT
			4	Osvetnik	1929		

## OTHER FIGHTING SHIPS



RMON	Morava	1	1	Morava	1892		448t, 54.0x9.0x1.2m, 2b,2vte, 1200hp, 10kts, 84p; 50belt, 19deck, 75CT; 2x1-120/35, 1x1-66/42, 1x1-15
	Sava	1	2	Sava	1904		470t, 57.7x9.5x1.2m, 2b,2vte, 1400hp, 13kts, 86p; 40belt, 25deck, 75CT; 2x1-120/35, 1x1-120/10, 1x1-66/50
	Drava	1	3	Drava	1914		540t, 57.9x10.3x1.3m, 2b,2vte, 1500hp, 13kts, 95p; 50belt, 19deck, 75CT; 1x2-120/40, 3x1-120/10, 2x1-66/50
	Vardar	1	4	Vardar	1915		580t, 62.0x10.3x1.3m, 2b,2vte, 1750hp, 13.5kts, 91p; 40belt, 25deck, 50CT; 1x2-120/40, 2x1-120/10, 2x1-66/50, 2x1-47/44

## COASTAL FORCES

PT	Uskok	2	1, 2	Uskok, Četnik	1928		15t, 16.8x3.4x1.2m, 2pe, 750hp, 40kts, 5p; 2-450TT
	Orjen	8	3-10	Orjen, Velebit, Dinara, Triglav, Suvobor, Rudnik, Kajmakčalan, Durmitor	1936 - 1939		62t, 28.0x4.3x1.5m, 3pe/1pe, 3300/100hp, 34kts, 16p; 1x1-40/56, 1x1-15, 2-550TT, 2DCR
YPR	Graničar	2	1, 2	Graničar, Stražar	1930	No picture	36t, 18.2x3.0x1.0m, 1d, 120hp, 10.7kts

## MINE WARFARE SHIPS

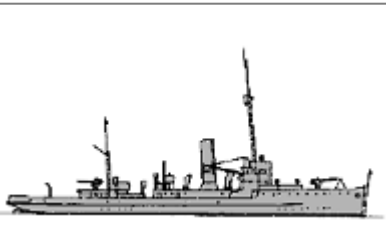
--	--	--	--	--	--	--	--

MS	D1	1	1	D2	1888		88t, 39.9x4.8x1.9m, 1b,1vte, 1000hp, 19kts, 16p; 2x1-37/23, MS
	Orao	6	2	Orao	1918		590t, 59.6x7.3x2.2m, 2b,2vte, 1840-1850hp, 16kts, 51p; 2x1-90/45, 24m, MS
			3	Galeb	1918		
			4	Gavran	1919		
			5	Jastreb	1919		
			6	Kobac	1918		
			7	Sokol	1919		
	Malinska	5	8	Marjan	1931		128t, 30.1x6.7x1.7m, 1b,2vte, 280hp, 11.6kts, 27p; 1x1-47/44, 34m or MS
			9	Mosor	1931		
			10	Malinska	1931		
			11	Meljine	1931		
			12	Mljet	1931		

*IN CONSTRUCTION*

## TORPEDO SHIPS

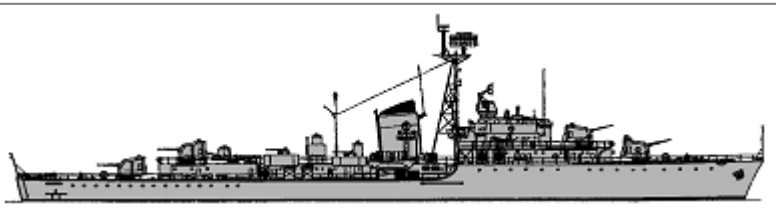
DD	Split	1	1	Split	1958		3000t, 120.0x11.3x3.5m, 3b,2gt, 55000hp, 38kts; 5x1-140/56, 5x2-40/56, 4x2-15, 2x3-533TT, 30m, 2DCR
----	-------	---	---	-------	------	---	---

## ESCORTS

PC	Beli Orao	1	1	Beli Orao	1940		660t, 65.0x8.1x2.8m, 2d, 1900hp, 18kts; 2x1-40/56
----	-----------	---	---	-----------	------	--	---