

[home](#)

THE NAVAL BALANCE 1935

Navies of the world

01/01/1935

1. *United Kingdom* - 1499 tt; 2. *USA* - 1456 tt; 3. *Japan* - 1105 tt; 4. *France* - 728 tt; 5. *Italy* - 504 tt; 6. *Soviet Union* - 267 tt; 7. *Germany* - 179 tt; 8. *Argentina* - 124 tt; 9. *Spain* - 121 tt

tt - thousand ton



[ALBANIA](#)

[ARGENTINA](#)

[AUSTRALIA](#)

[AUSTRIA](#)

[BELGIUM](#)

[BRAZIL](#)

[BULGARIA](#)

[CANADA](#)

[CHILE](#)

[CHINA](#)

[COLOMBIA](#)

[CUBA](#)

[CZECHOSLOVAKIA](#)

[DENMARK](#)

[DOMINICAN REPUBLIC](#)

[ECUADOR](#)

[EGYPT](#)

[ESTONIA](#)

[FINLAND](#)

[FRANCE](#)

[GERMANY](#)

[GREECE](#)

[HUNGARY](#)

[ICELAND](#)

[INDIA](#)

[IRELAND](#)

[ITALY](#)

[JAPAN](#)

[LATVIA](#)

[LITHUANIA](#)

[MANCHUKUO](#)

[MEXICO](#)

[NETHERLANDS](#)

[NEW ZEALAND](#)

[NORWAY](#)

[PARAGUAY](#)

[PERSIA](#)

[PERU](#)

[POLAND](#)

[PORTUGAL](#)

[ROMANIA](#)

[SIAM](#)

[SOVIET UNION](#)

[SPAIN](#)

[SWEDEN](#)

[TURKEY](#)

[UNITED KINGDOM](#)

[UNITED STATES OF AMERICA](#)

[URUGUAY](#)

[VENEZUELA](#)

[YUGOSLAVIA](#)

1576501

[Website Hit Counter](#)

[home](#)[World navies yesterday](#)[1935](#)

Albania 01 January 1935

OTHER FIGHTING SHIPS

PG	Shqipnía	2	1	Shqipnía	1922		193t, 43.0x6.0x1.4m, 1b,2vte, 600hp, 14kts, 35p; 1x1-88/30
			2	Skënderberg	1918		

COASTAL FORCES

YP	Tirana	4	1-4	Tirana, Saranda, Durrës, Shëngjun	1926	No picture	46t, 24.4xxm, d, 450hp, 17kts; 1x1-76/40
----	--------	---	-----	-----------------------------------	------	------------	--

© Ivan Gogin, 2011-15

[home](#)[World navies yesterday](#)[1935](#)

Argentina 01 January 1935

BATTLESHIPS

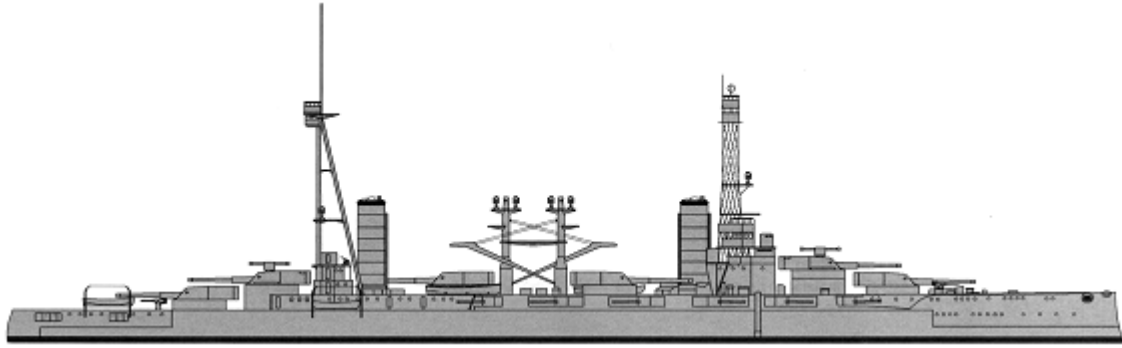
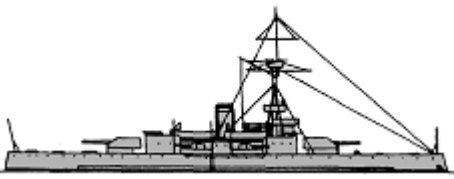

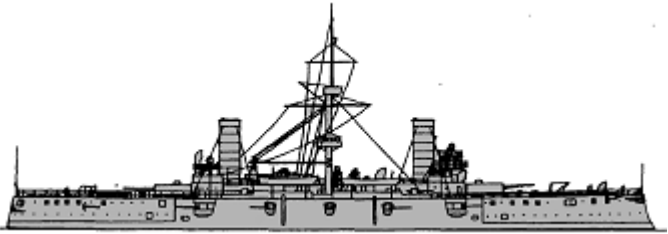
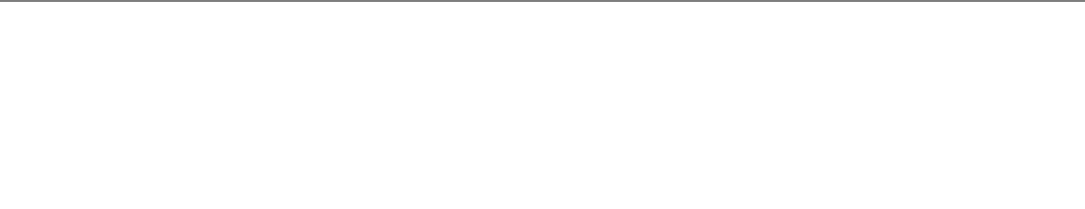

BB	Rivadavia	1	Rivadavia	1914		<p>30600t, 181.3x30.0x8.5m, 18b,3gt, 45000hp, 20kts, 1130p;280belt (76+38)deck, 305turrets, 305CT; 6x2-305/50, 12x1-152/50, 4x1-76/50, 2-533TT</p>
		2	Moreno	1915		
BC	Nueve de Julio	1	Libertad	1892		<p>2595t, 70.1ppx13.1x4.0m, 4b,2vte, 2800hp, 14kts, 230p; steel: 203belt, 37deck, 127turrets, 102CT; 2x1-240/35, 4x1-120/40, 4x1-47/40</p>
		2	Independencia			

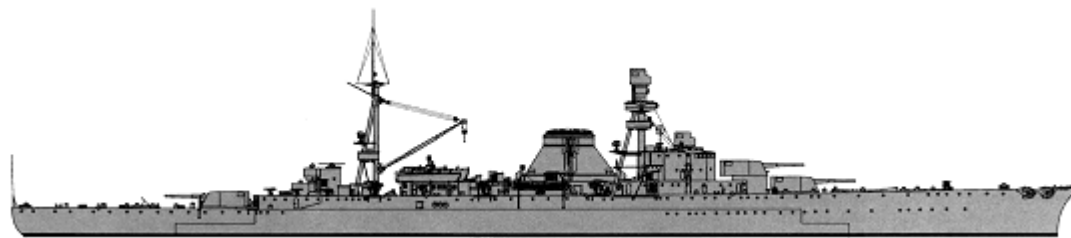
CRUISERS

CA	Garibaldi	1	San Martin	1898		<p>6775t, 111.7x18.2x7.1m, 8b(1)-16b(2),2vte, 13000hp, 20kts, 500-540hp; Harvey(1): 150belt, 37deck, 150turrets, 150CT; 2x1-254/40(2), 2x2-203/45(1), 10x1-152/40(1), 14x1-152/40(2), 6x1-120/40(1), 2x1-76/40(2), 4x1-57/40</p>
		2	Pueyrredon	1898		
	Veinticinco de Mayo	3	Almirante Brown	1931		<p>9000t, 170.8x17.8x4.7m, 6b,2gt, 85000hp, 32kts, 780p; 70belt, 25deck, 50turrets, 65CT; 3x2-190/52, 6x1-102/45, 6x1-40/39, 6-533TT, 2seaplanes (G5)</p>
		4	Veinticinco de Mayo	1931		

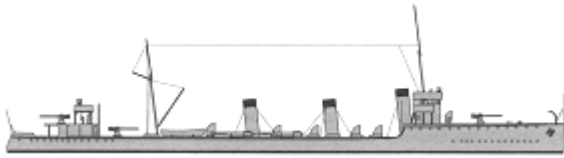

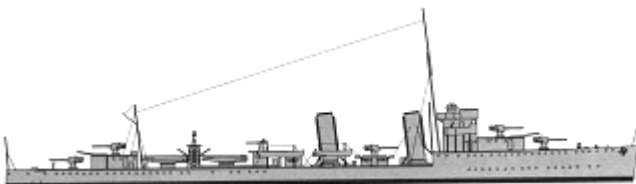
TORPEDO SHIPS

DD	Catamarca	1	Catamarca	1912		1357t, 88.1x8.3x2.6m, 2b,2t, 24000hp, 32kts, 150p; 3x1-102/50, 2x1-40/39, 2x2-533TT, 1DCT	
		2	Jujuy	1912			
	La Plata	3	Córdoba	1912		1368t, 90.0x9.0x2.8m, 5b,2t, 24000hp, 32kts, 150p; 3x1-102/50, 2x2-40/39, 2x2-533TT, 1DCT	
		4	La Plata	1912			
	Cervantes	5	Cervantes	1927		2087t, 101.5x9.7x3.7m, 4b,2gt, 42000hp, 36kts, 175p; 5x1-120/45, 1x1-76/45, 2x3-533TT, 2DCR	
		6	Juan de Garay	1927			
	Mendoza	3	7	Mendoza	1929		2120t, 102.1x9.7x3.8m, 4b,2gt, 42000hp, 36kts, 160p; 5x1-120/45, 1x1-76/45, 2x1-40/39, 2x3-533TT
			8	La Rioja	1929		
			9	Tucuman	1929		

SUBMARINES

SS	Santa Fé	3	1	Santa Fé	1933		935/1155t, 69.2x6.7x5.1m, 2d/em, 3000/1400hp, 17.5/9kts, 40p, 80m; 1x1-102/40, 8-533TT
			2	Santiago del Estero	1933		
			3	Salta	1933		

OTHER FIGHTING SHIPS

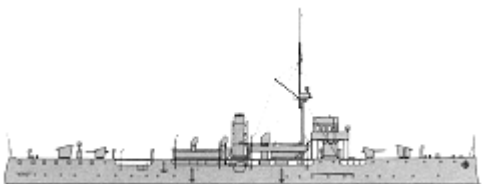
PGR	Rosario	2	1	Rosario	1909		1055t, 76.4x9.8x2.1m, 2b,2vte, 1300hp, 14.5kts, 145p; 76belt, 25deck, 76CT; 2x1-152/13, 6x1-76/40, 2x1-40/39
			2	Paraná	1909		

MINE WARFARE SHIPS

MS	M1	4	1	M1	1916		513(1)-503(2-4)t, 58.3(1)-58.2(2-4)x7.3x2.3m, 2b,2vte, 1800(1,4)-1890(2,3)hp, 16.5kts, 40p; 3x1-75/55, 30m, MS
			2	M2	1916		
			3	M3	1916		
			4	M4	1916		
MS	M5	5	5	M5	1918		553(5-7)-548(8)-564(9)t, 58.2(5)-59.3(6-9)x 7.3(5,8)-7.4(6,7,9)x 2.3(5,9)-2.2(6,7,8)m, 2b,2vte, 1850hp, 16.3(5,6,8)-16(7,9)kts, 40p; 3x1-75/55, 30m, MS
			6	M6	1919		
			7	M7	1919		
			8	M8	1918		
			9	M9	1918		

© Ivan Gogin, 2011-15

[home](#)

[World navies yesterday](#)

[1935](#)

AUSTRALIA 01 January 1935

AIRCRAFT CARRYING SHIPS

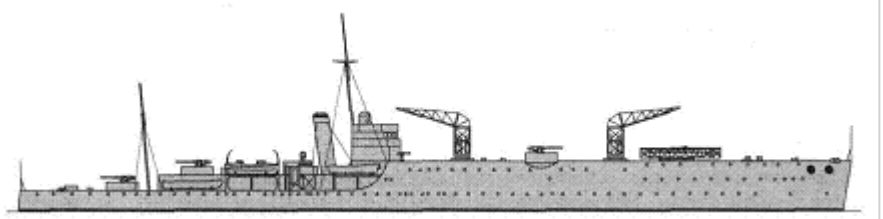

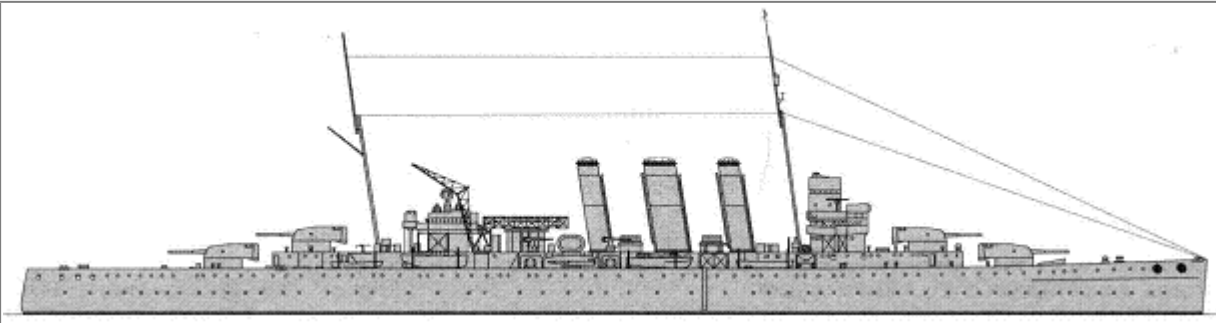
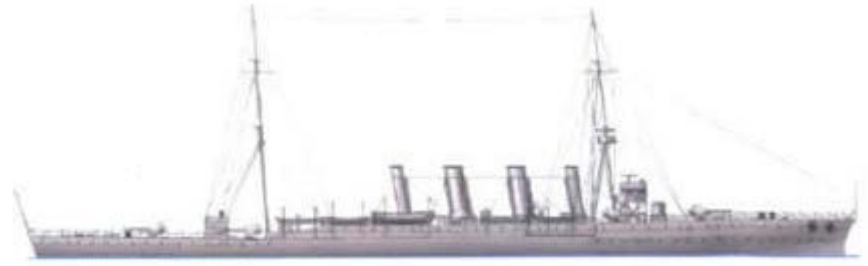

AV	Albatross	1	1	Albatross	1929		6350t, 135.3x23.7x5.3m, 4b, 2gt, 12000hp, 21kts, 450p; 4x1-120/40, 4x1-47/40, 4x1-40/39, 9seaplanes (6 Fairey IIID)
----	-----------	---	---	-----------	------	--	---

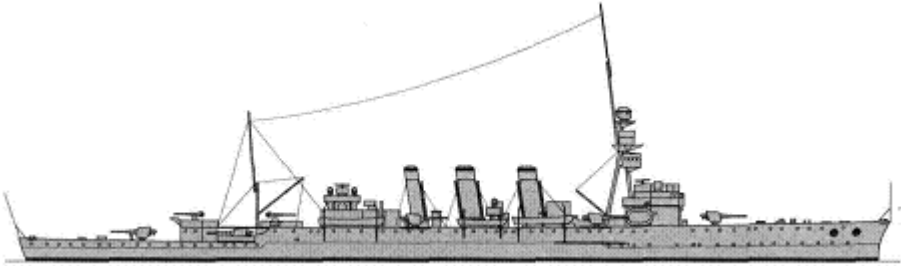
CRUISERS

CA	Kent	2	2	Canberra	1928		13400-13540t, 192.0-192.9x20.8x6.3m, 8b, 4gt, 80000hp, 31.5kts, 710p; 25belt, 111magazines, 38deck, 25turrets; 4x2-203/50, 4x1-102/45, 4x1-47/40, 4x1-40/39, 2x4-533TT
CL	Chatham	1	1	Brisbane	1916		6000t, 139.6x14.9x4.9m, 12b, 4t, 25000hp, 25.5kts, 475p; 51belt, 102shields, 38deck, 102CT; 8x1-152/45, 1x1-76/45, 4x1-47/40, 2-533TT
							6160t, 141.0x14.9x4.9m, 12b, 2gt, 25500hp, 25.5kts, 480p;

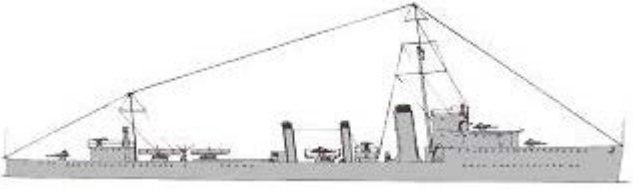
	Birmingham	1	2	Adelaide	1922		51belt, 102shields, 38deck, 102CT; 9x1-152/45, 1x1-76/50, 1x1-76/45, 4x1-47/40, 2-533TT
--	------------	---	---	----------	------	---	---

TORPEDO SHIPS

DL	Parker	1	1	Anzac	1917		1912t, 99.0x9.7x3.7m, 4b, 3t, 36000hp, 34kts, 116p; 4x1-102/40, 2x1-40/39, 2x2-533TT
	V	1	2	Vampire	1917		1400t, 95.1x9.0x3.2m, 3b, 2gt, 27000hp, 34kts, 115p; 4x1-102/45, 2x1-40/39, 2x3-533TT, 1DCR
DD	V-Admiralty	1	1	Vendetta	1917		1523t, 95.1x9.0x3.2m, 3b, 2gt, 27000hp, 34kts, 134p; 4x1-102/45, 1x1-40/39, 2x3-533TT, 2DCT, 1DCR, MS
	W-Admiralty	2	2	Voyager	1918		1490t, 95.1x9.0x3.2m, 3b, 2gt, 27000hp, 34kts, 134p; 4x1-102/45, 1x1-40/39, 2x3-533TT, 2DCT, 1DCR, MS
			3	Waterhen	1918		
	S-Admiralty	5	4	Stalwart	1918		1225t, 84.1x8.1x2.7m, 3b, 2gt, 27000hp, 36kts, 90p; 3x1-102/40, 1x1-40/39, 2x2-533TT, 2DCT, 1DCR
			5	Success	1919		
6			Swordsman	1919			
		7	Tasmania	1919			
		8	Tattoo	1919			

ESCORTS

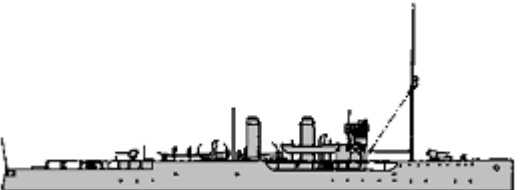
SL	Acacia	1	1	Mallow	1915		1275t, 80.0x10.1x3.4m, 2b, 1vte, 1800hp, 16.5kts, 90p; 2x1-102/40, 2x1-40/39, 2DCT, 1DCR, MS
			2	Geranium	1916		

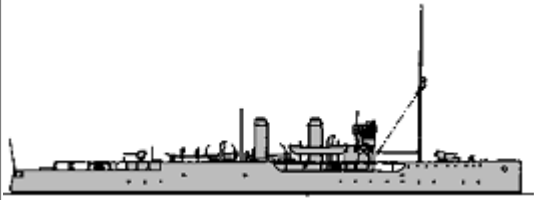
Arabis	2	3	Marguerite	1916		1350t, 81.7x10.2x3.4m, 2b, 1vte, 2000hp, 16kts, 104p; 2x1-102/40 or 2x1-120/40, 2x1-47/50, 2DCT, 1DCR, MS
--------	---	---	------------	------	---	---

NAVAL AVIATION (*approximately, maximal number of delivered planes signed*)

Seaplanes	R: 26 Seagull II
-----------	------------------

© Ivan Gogin, 2010-15

[home](#)

[World navies yesterday](#)

[1935](#)

Austria 01 January 1935

RIVER BOATS



PGR	Fogas	1	1	Birago	1916		60t, 36.0x4.6x0.9m, 2b,2vte, 800hp, 12kts, 27p; 5belt, 4deck, 5turret, 5CT; 1x1-66/30
-----	-------	---	---	--------	------	---	---

© Ivan Gogin, 2011-15

[home](#)[World navies yesterday](#)[1935](#)

Belgium 01 January 1935

TORPEDO SHIPS

TB	A1 PC	2	1	Oever	1915		137t, 41.6x4.6x1.2m, 1b,1vte, 1093hp, 19kts, 28p; 1x1-50/40, 2x1-450TT, 4m, MS		
			2	West Diep	1915				
	A22 PC	2	3	Zand	1917				250t, 50.0x5.3x2.1m, 1b,1gt, 3250hp, 25kts, 29p; 2x1-88/30, 1x1-450TT, MS
			4	Wielingen	1917				

ESCORTS

SL	Zinnia	1	1	Zinnia	1915		1275t, 80.0x10.1x3.4m, 2b,1vte, 1400hp, 14kts, 90p
----	--------	---	---	--------	------	--	--

© Ivan Gogin, 2011-15

[home](#)

[World navies yesterday](#)

[1935](#)

Brazil 01 January 1935

BATTLESHIPS

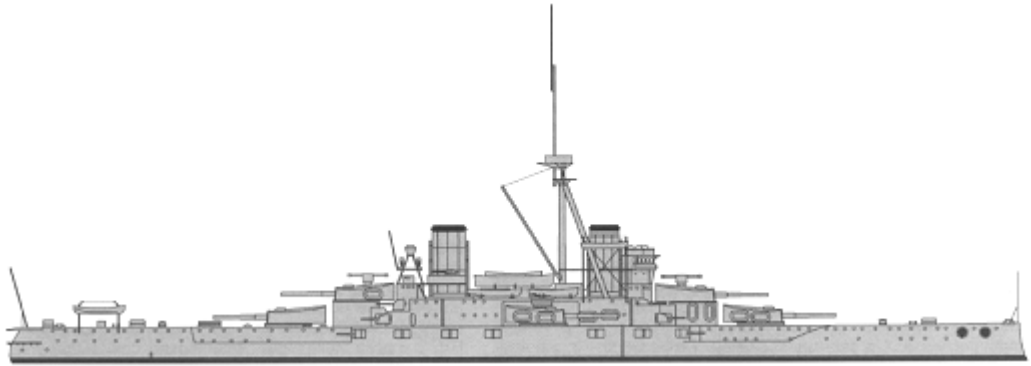
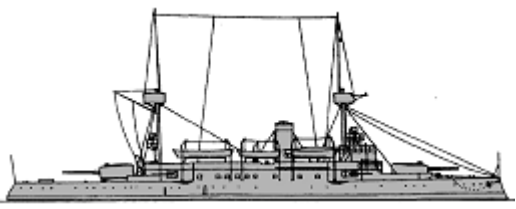
BB	Minas Gerais	1	Minas Gerais	1910		21200t, 165.5x25.33x7.6m, 18b,2vte, 23500hp, 21kts, 900p; 229belt, 51deck, 229turrets, 305CT; 6x2-305/45, 12x1-120/50, 2x1-76/50, 8x1-37/32(1), 4x2-20/60(2)
		2	São Paulo	1910		
BC	Marshal Deodoro	1	Marshal Floriano	1901		3162t, 81.5x14.4x4.2m, 8b,2vte, 3400hp, 15kts, 200p; Harvey: 350belt, 45deck, 220turrets, 125CT; 2x1-234/45, 4x1-120/50, 6x1-57/40, 2-450TT

CRUISERS

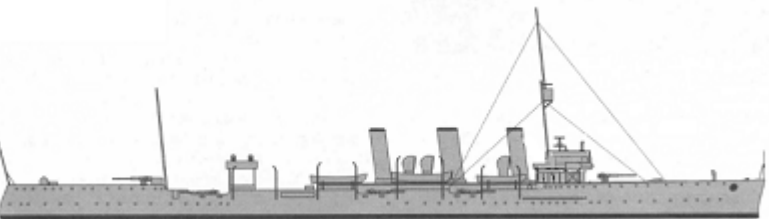
CL	Bahia	1	Bahia	1910		3185t, 122.4x11.9x4.4m, 6b,3gt, 22000hp, 28kts, 350p; 31slopes, 19deck, 76CT; 10x1-120/50, 4x1-76/40, 4x1-47/40, 2x2-533TT
		2	Rio Grande do Sul	1910		

TORPEDO SHIPS

		1	Piaui	1909	
		2	Rio Grande do Norte	1909	

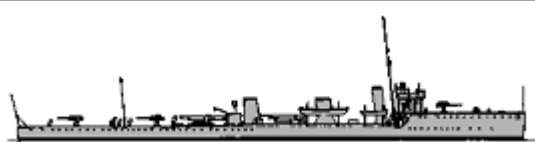
DD	Pará	3	Paraíba	1909		560t, 73.2ppx7.2x2.4m, 2b,2vte, 8000hp, 27kts, 130p; 2x1-102/40, 4x1-47/40, 2x1-450TT	
		7	4	Alagoas			1910
			5	Sergipe			1910
			6	Santa Catharina			1910
			7	Mato Grosso			1909
	Alexandrino Dealenca	1	8	Maranhão	1914		1300t, 81.5x8.2x2.9m, 4b,2t, 24500hp, 29kts, 73p; 3x1-102/40, 2x1-47/50, 2x2-450TT

SUBMARINES

SS	Humaytá	1	1	Humaytá	1929		1450/1884t, 86.7x7.8x4.3m, 2d/em, 4000/1000hp, 18.5/10kts, 61p, 100m; 1x1-120/41, 2x1-13.2, 6-533TT, 16m
----	---------	---	---	---------	------	--	--

OTHER FIGHTING SHIPS

RMON	Pernambuco	1	1	Pernambuco	1910		470t, 44.5x7.3x1.6m, 2b,2vte, 800hp, 11kts, 60p; 168belt, 102deck, 152turret, 89CT; 1x2-120/45, 2x1-57/43, 2x1-37/32
APGR	-	3	1	Oyapock	1908		295t
			2	Tenente Mário Alves	1913		280t
			3	Amapá	1912		320t

MINE WARFARE SHIPS



AML	-	1	1	Tenente Maria do Couto			340t; 30m
AMS	-	2	1	Heitor Perdigão	1921		500t
			2	Muniz Freire	1921		500t

© Ivan Gogin, 2011-15



[home](#)[World navies yesterday](#)[1935](#)

Bulgaria 01 January 1935

TORPEDO SHIPS

TB	Druzki	4	1	Druzki	1908		98t, 38.0x4.4x1.3m, 2b,1vte, 1950hp, 26kts, 32p; 2x1-37/83, 1x2-450TT, MS
			2	Smeli	1908		
			3	Khrabri	1908		
			4	Strogi	1909		
	Vasil Levski	2	5, 6	Vasil Levski, Khristo Botev	1877-1878		20t, 18.3x2.3x1.1m, 1b,1vc, 220hp, 13kts, 9p

COASTAL FORCES

PS	Belomorets	2	1, 2	Belomorets, Chernomorets	1917		87t, 33.5x4.5x1.7m, 3pe, 660hp, 18kts, 27p; 1x1-47/50
YP	Minyor	2	1, 2	Vzriv, Kapitan-Leytenant K. Minkov	1918		41t, 23.4x3.7x1.5m, 2pe, 440hp, 14kts, 16p; 1x1-75/35, 1DCT

© Ivan Gogin, 2011-15

[home](#)[World navies yesterday](#)[1935](#)

CANADA 01 January 1935

TORPEDO SHIPS

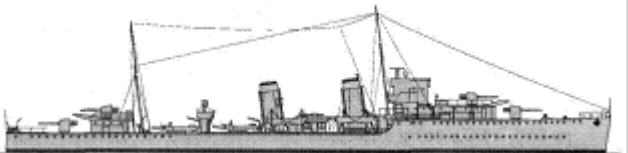
DD	S-Thornycroft	1	Champlain	1919		1240t, 84.1x8.3x3.2m, 3b, 2gt, 27000hp, 36kts, 90p; 3x1-102/40, 1x1-40/39, 2x2-533TT, 2x1-450TT, 2DCT, 1DCR
		2	Vancouver	1919		
A RCN		3	Saguenay	1931		1815t, 97.5x9.9x3.7m, 3b,2gt, 32000hp, 35kts, 138p; 4x1-120/45, 2x1-40/39, 2x4-533TT, 3DCR, MS
		4	Skeena	1931		

MINE WARFARE

TR	Ypres	5	1	Festubert	1917	No picture	440t, ~42x7.1x4.1m, 1b, 1vte, ?hp, 10.5kts, ?p; 1x1-76/40, MS
			2	Ypres	1917		
			3	Armentiers	1918		
			4	Arras	1918		
			5	Givenchy	1918		
DF	Admiralty wooden	1	1	Ebbtide	1917		175t, 28.7x6.1x2.2m, 1b, 1vte, 270hp, 9kts, ?p; 1x1-57/40, MS



[home](#)[World navies yesterday](#)[1935](#)

Chile 01 January 1935

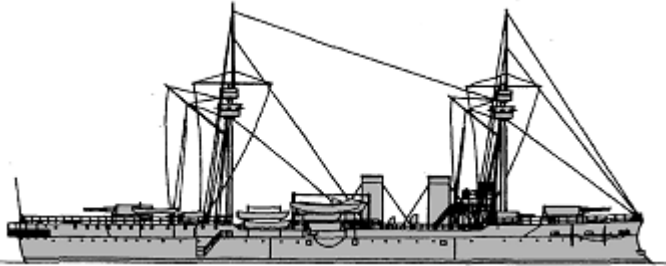
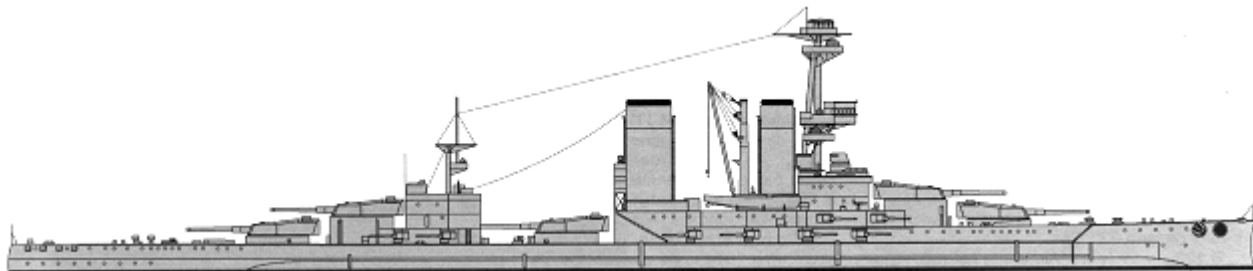
CAPITAL SHIPS

BB	Capitán Prat	1	1	Capitán Prat	1893		6901t, 100.0ppx18.5x7.0m, 12b,2hte, 12000hp, 19kts, 480p; Creusot steel; 300belt, 50deck, 275barbettes, 265CT; 4x1-240/36, 4x2-120/45, 10x1-57/40, 2-450TT
	Almirante Latorre	1	2	Almirante Latorre	1915		32800t, 201.5x31.4x8.7m, 21b,4gt, 55000hp, 22.4kts, 1167p; 229belt, (25+37)deck, 254turrets, 279CT; 5x2-356/45, 14x1-152/50, 4x1-102/45, 4-533TT, 1seaplane(Fairey IIIF)

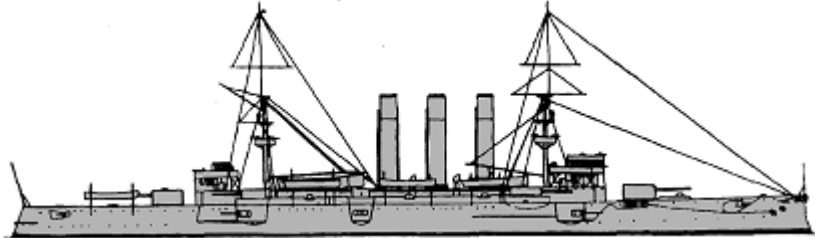
CRUISERS

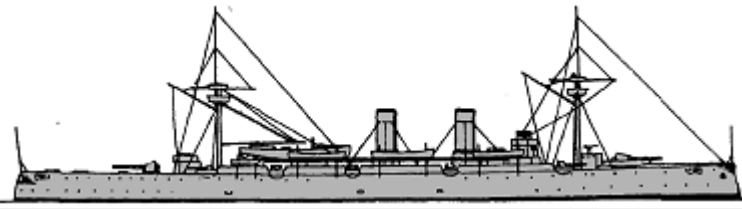
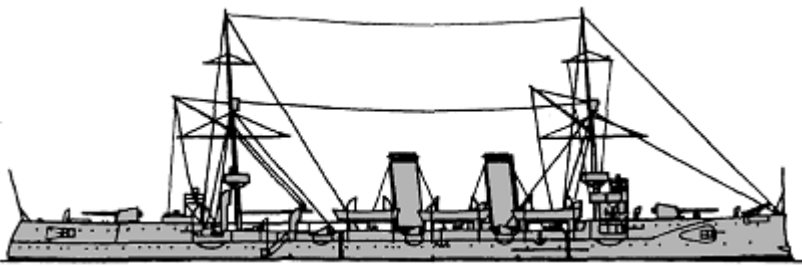

CA	O'Higgins	1	1	O'Higgins	1898		8500t, 135.2x19.1x6.7m, 30b,2vte, 16000hp, 21kts, 500p; Harvey; 178belt, 51deck, 178turrets, 229CT; 4x1-203/40, 10x1-152/40, 13x1-76/40, 3-450TT
	Blanco Encalada	1	1	Blanco Encalada	1894		4568t, 112.8ppx14.2x5.6m, 8b,2vte, 14600hp, 22.8kts, 427p; Steel; 102slopes, 44deck, 152shields, 152CT; 2x1-203/40, 10x1-152/40, 5x1-76/40, 1x1-40/39

CL					
	Chacabuco	1 2	Chacabuco	1902	

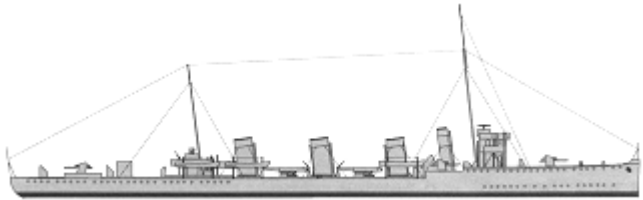
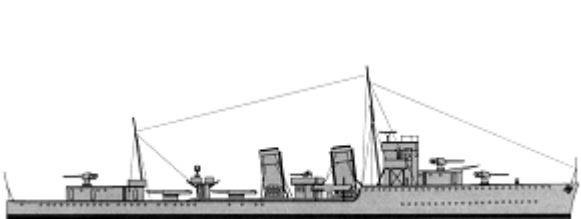
TORPEDO SHIPS

DD	Almirante Lynch	1	Almirante Lynch	1913		1850t, 100.8x9.9x3.4m, 6b,3t, 30000hp, 31kts, 160p; 6x1-102/40, 2x2-533TT
		2	Almirante Condell	1914		
DD	Serrano	3	Sargeno Aldea	1929		1430t, 91.4x8.8x3.9m, 3b,2gt, 28000hp, 35kts, 130p; 3x1-120/45, 1x1-76/40, 2x3-533TT, 2DCT, 20m(4,5,7), MS(3,6,8)
		4	Ingeniero Hyatt	1929		
		5	Capitán Orella	1928		
		6	Guardiamarina Riquelme	1929		
		7	Teniente Serrano	1928		
		8	Cirujano Videla	1929		

SUBMARINES

SS	H1	6	1	H1	1915		364/434t, 45.8x4.7x3.8m, 2d/em, 480/620hp, 13/11kts, 22p, 30m; 4-450TT
			2	H2	1915		
			3	H3	1915		
			4	H4	1916		
			5	H5	1916		
			6	H6	1916		
SS	Capitán O'Brien	3	7	Capitán O'Brien	1929		1540/2020t, 79.3x8.5x4.2m, 2d/em, 2750/1300hp, 15/9kts, 54p, 95m; 1x1-120/45, 8-533TT
			8	Almirante Simpson	1929		
			9	Capitán Thomson	1929		

ESCORTS

PC	Yelcho	1	1	Yelcho	1908	No picture	467t, 39.0x7.0x2.9m, 1vte, 350hp, 12kts; 1x1-37/23
	Piloto Sibbald	1	2	Piloto Sibbald	1916	No picture	1100t, 43.1x8.7x3.4m, 2b,2vte, 1200hp, 11.5kts, 18p; 1x1-37/23

MINE WARFARE SHIPS

ML	Elicura	3	1	Elicura	1920		545t, 52.6x7.5x3.4m, 3b,2vte, 1400hp, 14.5kts, 42p; 2x1-76/40, 50m
			2	Leucoton	1920		
			3	Orompello	1920		

© Ivan Gogin, 2012-15



[home](#)[World navies yesterday](#)[1935](#)





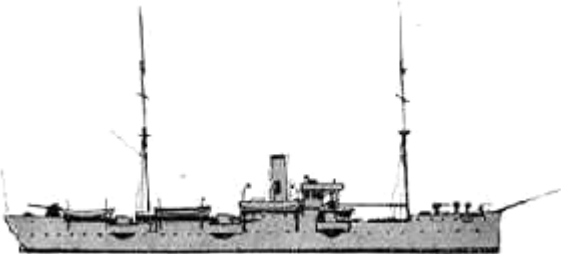

China 01 January 1935

AIRCRAFT CARRYING SHIPS

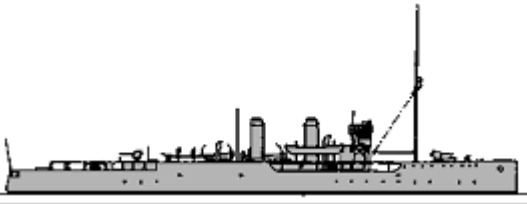
AV	Chen Hai	1	1	Chen Hai	1904	No picture	3000t, 77.2x11.4x4.0m, 1b,1vte, 136hp; 1x1-12/50, 4x1-76/50, 3seaplanes
	Wei Hai	1	2	Wei Hai	1897	No picture	2500t, 70.1x10.1x4.0m, 1b,1vte, 93hp; 2x1-76/50, 3seaplanes
	Teh Sheng	2	3	Teh Sheng	1923		932t, 62.6x9.5x2.4m, 2b,2vte, 3300hp, 16kts, 93p; 1x1-120/45, 1x1-76/50, 2seaplanes
			4	Wei Sheng	1923		







CRUISERS

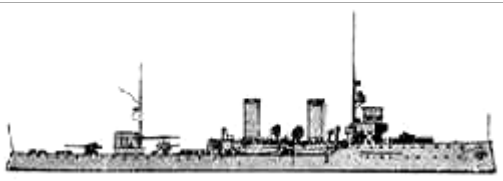

Tung Chi	1	1	Tung Chi (TS)	1896		1900t, 77.0ppx10.4x4.9m, 4b,1vc, 1600hp, 11.6kts, 335p; 2x1-152/50, 5x1-120/45, 3x1-57/40, 8x1-37/23
Hai Yung	3	2	Hai Yung	1898		2950t, 100.0x12.4x5.8m, 8b,2vte, 7500hp, 19.5kts, 244p; 32deck, 70slopes, 51shields, 37CT; 3x1-150/40, 8x1-105/40, 6x1-47/40, 1x1-40/39, 3-356TT
		3	Hai Chou	1898		
		4	Hai Chen	1898		
Hai Chi	1	5	Hai Chi	1899		4515t, 129.2x14.2x5.5m, 12b,4vte(2), 17000hp, 24kts, 350p; 37deck, 127slopes, 114gunhouses, 152CT; 2x1-203/45, 10x1-120/45, 12x1-47/40, 4x1-37/32, 5-450TT

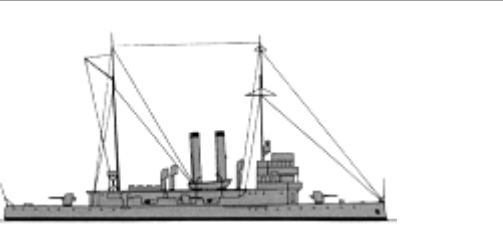
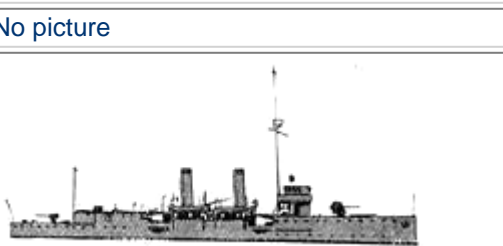
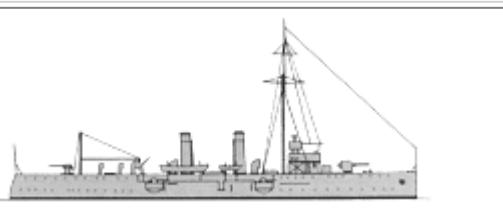
SL	Hai Chow	1	1	Chow	1916		1350t, 81.7x10.2x3.4m, 2b,1vte, 2000hp, 16kts, 100p; 1x1-120/45, 2x1-76/50, 2x1-37/32
PC	Yi Sheng	4	1	Yi Sheng	1911		350(1)-300(2-4)t, 36.7(1)-38.1(2)-36.6(3,4) x6.3(1)-6.4(2-4) x3.4(1)-2.1(2)-2.3(3,4)m, 1b,1vte, 500hp, 10kts, 37(1)-42(2)-47(3,4)p; 1x1-76/50(2-4), 1x1-65/60(1), 1x1-57/40
			2	Yung Sheng	1928		
			3	Kung Sheng	1931		
			4	Jen Sheng	1931		
	Hai Yen	1	5	Hai Yen	1917	No picture	60t, 19.8x3.7x0.7m, 1b,2vte, 60hp, 10kts; 1x1-37/32
	Hai Ku	2	6	Hai Ku	1917		200t, 34.1x5.5x2.6m, 1b,2vte, 300hp, 10.5kts, 22p; 2x1-37/32
			7	Hai Hung	1917		
	Hai Fu	2	8	Hai Fu	1917		166t, 33.2x5.2x2.4m, 1b,1vte, 220hp, 10.5kts, 22p; 1x1-37/32
			9	Hai Ou	1917		
	Hai Hao	2	10	Hai Hao	1917		230t, 32.3x5.5x2.0m, 1b,1vte, 200hp, 12kts, 22p; 4x1-37/32
			11	Hai Peng	1920		
Shun Sheng	1	12	Shun Sheng	1928		350t, 44.5x7.5x1.8m, 1b,1vte, 500hp, 10.7kts, 65p; 2x1-76/40, 2x1-37/32	
Hai Ning	10	13	Hai Ning	1932		300t, 43.5x6.1x2.4m, 1b,1vte, 600hp, 10kts, 44p; 2x1-57/40 or 2x1-40/39	
		14	Kiang Ning	1932			
		15	Wu Ning	1933			
		16	Sui Ning	1933			
		17	Wei Ning	1933			
		18	Su Ning	1933			
		19	Chung Ning	1934			
		20	Yi Ning	1934			
21	Chang Ning	1934					
22	Cheng Ning	1934					

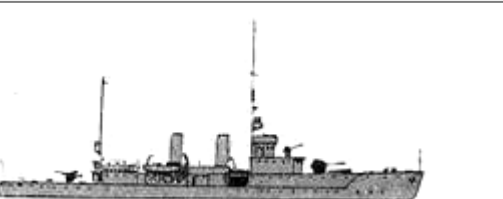
OTHER FIGHTING SHIPS

		1	Tze Kiang	1903		900t, 79.2x8.1x3.5m, 4b,2vte, 6500hp, 20.5kts, 140p; 25belt, 25deck; 2x1-120/45, 1x1-76/50, 2x1-57/40,
--	--	---	-----------	------	--	--

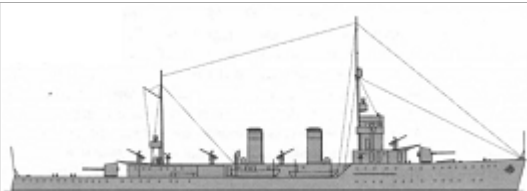
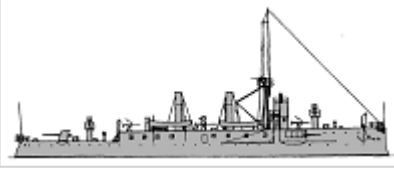
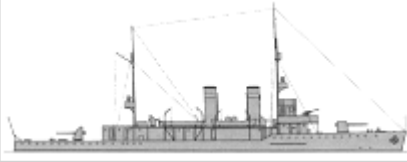
PG	Chien Wei	2	2	Ta Tung	1903		1x1-37/32
	Kiang Yuan	3	3	Kiang Yuan	1905		565t, 54.1x8.5x2.1m, 2b,2vte, 950hp, 13kts, 85p; 1x1-120/40, 1x1-76/40, 4x1-47/40
			4	Kiang Li	1907		
			5	Kiang Chen	1907		
	Chu Tung	6	6	Chu Tung	1906		752t, 61.0x9.0x2.4m, 2b,2vte, 1350hp, 13kts, 117p; 2x1-120/40, 2x1-76/40
			7	Chu Chien	1906		
			8	Chu Tai	1906		
			9	Chu Yu	1907		
			10	Chu Yiu	1907		
	11	Chu Kuan	1907				
Wu Feng	1	12	Wu Feng	1912	No picture	200t, 37.8x6.1x2.1m, 1b,1vte, 300hp, 10kts, 46p; 2x1-65/60	
Yung Feng	2	13	Chung Shan	1913		1020t, 65.8x9.0x2.4m, 2b,2vte, 1350hp, 13kts, 108p; 25deck; 1x1-105/40, 1x1-76/50, 4x1-47/40, 2x1-37/32	
		14	Yung Hsiang	1913			
Yung Chien	2	15	Yung Chien	1915		1039t, 65.7x9.0x3.5m, 2b,2vte, 1350hp, 13kts, 105p; 25deck; 1x1-102/40, 1x1-76/40, 4x1-47/40, 2x1-37/32	
		16	Yung Chi	1916			
Hsien Ning	1	17	Hsien Ning	1929		500t, 54.9x7.3x2.0m, 2b,2vte, 2500hp, 17kts, 115p; 1x1-120/45, 1x1-102/45, 3x1-57/40, 1x1-47/50	
Yung Sui	1	18	Yung Sui	1929		800t, 68.0ppx9.1x1.8m, 2b,2vte, 4000hp, 18.5kts, 100p; 1x1-152/50, 1x1-120/45, 3x1-76/40, 4x1-57/40, 1x1-40/39	
Ming Chuen	1	19	Ming Chuen	1930		500t, 61.8x7.9x1.8m, 2b,2vte, 2400hp, 16.6kts, 146p; 1x1-120/45, 1x1-102/45, 1x1-76/40, 2x1-57/40, 1x1-47/40	
I Hsien	1	20	I Hsien	1930		1650t, 83.8x10.5x3.4m, 3b,2vte, 4000hp, 16kts, 173p; 1x1-152/50, 1x1-140/50, 4x1-76/40, 2x1-47/40	

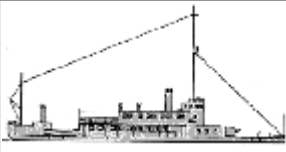
							
	Fu Yu	1	21	Fu Yu	1905		750t, 63.0x8.3x2.5m, 4b,2vte, 1800hp, 16.7kts, 118p; 12deck; 2x1-76/40, 1x1-40/39, 2x1-37/32
	Ming Sen	1	22	Ming Sen	1931		600t, 64.0x8.2x2.0m, 2b,2vte, 3600hp, 18kts, 115p; 1x1-120/45, 1x1-102/45, 2x1-76/40, 2x1-47/40
APG	-	1	1	Hoi Fu	1904		680t; 1x1-76/50
PR	Chiang Kung	4	1	Chiang Kung	1909		200t, 44.0x6.0x1.6m, 1b,2vte, 500hp, 14kts, 62p; 1x1-76/40
			2	Chiang Chi	1909		
			3	Chiang Ku	1909		
			4	Chiang Tai	1909		
	Chiang Hsi	2	5	Chiang Hsi	1912		140t, 43.9(5)-44.5(6)x7.5(5)-7.3(6)x0.6m, 2b,2vte, 450(5)-500(6)hp, 12kts, 49p; 1x1-37/32(5), 2x1-37/32(6)
			6	Chiang Kun	1912		
	Chien Chung	1	7	Kung Chen	1916	No picture	90t, 35.5x5.6x0.6m, 1b,2vte, 450hp, 11kts, 42p; 1x1-88/22
	Chung Yun	2	8, 9	Chung Yun, Chung Hai	1928	No picture	60t, 25.6x4.5x0.8m, 1b,1vte, 100hp, 10.5kts, 31p; 4x1-37/32
	Chien Yu	2	10	Chien Yu	1929	No picture	225t, 36.8x6.5x1.3m, 1b,2vte, 400hp, 10.5kts, 52p; 1x1-57/40, 2x1-40/39
			11	Chien Shun	1929		
Chai We	2	12	Chai We	1932	No picture	210t, 43.0x7.4x1.5m, 1b,2vte, 520hp, 12kts; 1x1-76/40, 1x1-47/40	
		13	Chang Chiang	1932			

COASTAL FORCES

PT	Kuai 3	2	1, 2	Kuai 3,4	1931		16t, 16.0x4.0x1.3m, 2pe, 1500hp, 40kts, 7p; 2-450TT
	Kuai 1	2	3, 4	Kuai 1,2	1933		14t, 16.8x3.4x1.1m, 2pe, 950hp, 43kts, 5p; 2-450TT

CUSTOMS CRUISERS

	Fen Hsing	3	1	Fen Hsing	1933	No picture	500t, 58.0x9.8x3.4m, 2b,2vte, 2000hp, 13kts; 2x1-47/40
			2	Lien Hsing	1933		
			3	Hua Hsing	1933		
			4	Hai Ping	1933		

CC	Hai Ping	7	5	Hai Yen	1933	No picture	450t, 42.0x7.6x2.5m, 2b,2vte, 12kts; 2x1-47/40
			6	Hai An	1933		
			7	Hai Sui	1934		
			8	Hai Ching	1934		
			9	Hai Ho	1934		
			10	Hai Tung	1934		
	Wen Hsing	2	11	Wen Hsing	1934	No picture	340t, 43.5x7.0x2.0m, 2d, 1400hp, 15kts; 2x1-47/40
			12	Yun Hsing	1934		
	Shu Hsing	2	13	Shu Hsing	1934	No picture	235t, 42.8x7.0x1.2m, 2d, 1400hp, 15kts; 2x1-47/40
			14	Cha Hsing	1934		

© Ivan Gogin, 2011-15



[home](#)[World navies yesterday](#)[1935](#)

Colombia 01 January 1935

TORPEDO SHIPS

DD	Antioquia	2	1	Antioquia	1934		1563t, 98.5x9.4x2.7m, 3b,2gt, 33000hp, 36kts, 147p; 4x1-120/50, 3x1-40/39, 2x4-533TT, 20m, 2DCT
			2	Caldas	1934		

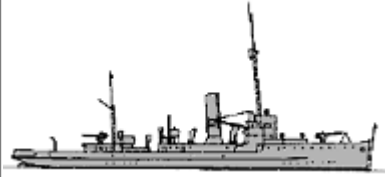
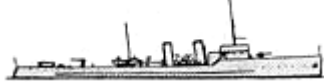
OTHER FIGHTING SHIPS

PG	Carabobo	3	1	Carabobo	1925	No picture	120t, 33.0x6.0x2.5m, 1b,1vte, 300hp, 13kts, 37p; 1x1-75/35, 1x1-37/50
			2	Boyaca	1925		
			3	Pichincha	1925		
PG	Bogota	2	4	Bogota	1919		630t, 59.6x7.3x2.2m, 2b,2vte, 1850hp, 16kts, 40p; 1x1-88/45, 2x1-75/35, 2x2-13.2
			5	Cordova	1920		
APG	-	1	1	Mariscal Sucre	1909		125t; 2x1-76/40
PGR	Esperanza	2	1	Esperanza	1897	No picture	400t, 42.4ppx5.8x0.9m, sw, 430hp, 15kts; 3x1-37/23
			2	General Nerino	1895		
	Chercinto	1	3	Chercinto	1896	No picture	643t, 56.4x9.4x3.7m, 400hp, 12kts; 3x1-37/23
	Cartagena	3	4	Cartagena	1931		142t, 41.8x7.2x0.8m, 2sd, 600hp, 15.5kts, 39p; 1x1-76/40
5			Santa Marta	1931			
6	Barranquilla	1931					
APGR	-	1	1	Presidente Mosquera	1912		230t; 1x1-76/40

COASTAL FORCES

YPR	No1	4	1-4	No1-4	1913	No picture	20t, 24.0x3.8x1.2m, pe, 160hp, 12kts, 6p; 1x1-37/32
	A	1	5	A	1919		7t, 16.0x2.4x0.7m, 3pe, 780hp, 31.8kts, 7p
	B	2	6, 7	B, D	1918-1919		7t, 16.5x2.4x0.6m, 3pe, 680(6)-740(7)hp, 31.6kts, 7p
	C	1	8	C	1930	No picture	14t, 19.6x2.9x0.8m, 3pe, 1200hp, 34kts, 6p

© Ivan Gogin, 2011-15

[home](#)[World navies yesterday](#)[1935](#)

Cuba 01 January 1935

OTHER FIGHTING SHIPS

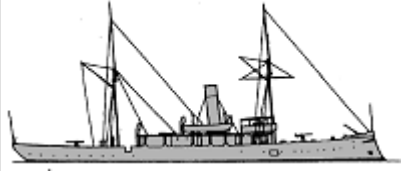
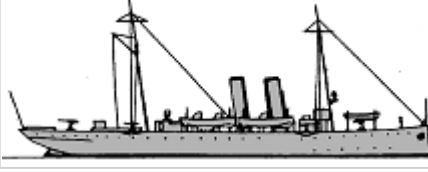
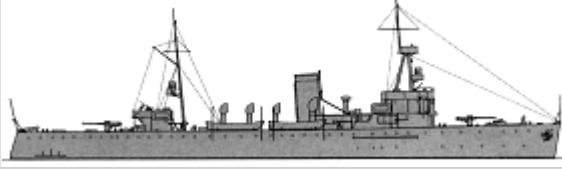
PG	Baire	1	1	Baire	1906		510t, 59.7x7.0x2.7m, 1vte, 1200hp, 14kts, 76p; 4x1-76/50, 2x1-37/40
	Santa Clara	1	2	Santa Clara	1911	No picture	52t, 32.0x1.8m, 12kts, 17p; 1x1-37/40
	Diez de Octubre	2	3	Diez de Octubre	1911	No picture	218t, 33.6x6.1x2.4m, 1vte, 12kts, 39p; 3x1-47/40
			4	Veinte y Cuatro de Febrero	1911		
	Patria	1	5	Patria	1911		1200t, 61.0ppx11.0x4.0m, 2vte, 4000hp, 16kts, 115p; 4x1-57/40, 4x1-47/40
	Cuba	1	6	Cuba	1911		2055t, 79.2x11.9x4.3m, 2vte, 6000hp, 18kts, 145p; 2x1-102/50, 4x1-57/40, 4x1-47/40, 4x1-37/40
	Habana	2	7,8	Habana, Pinar del Río	1912	No picture	80t, 30.5x5.5x1.3m, 1vte, 200hp, 12kts, 20p; 1x1-37/40
General Juan Bruno Zayas	1	9	General Juan Bruno Zayas	1914	No picture	300t, 50.0x3.4m, 11kts, 51p; 2x1-37/40	

COASTAL FORCES

SC	CS1	4	1-4	CS1-4	1918		85t, 33.5x4.5x1.7m, 3pe, 660hp, 18kts, 27p; 1x1-76/23, 1DCT
----	-----	---	-----	-------	------	---	---

COAST GUARD SHIPS

CGS	Veinte de Mayo	1	1	Veynte de Mayo	1895	No picture	203t, 45.7x5.6x3.2m, 500hp, 12kts, 43p; 2x1-47/40, 2x1-37/40
	Yara	1	2	Yara	1895	No picture	449t, 47.2x7.9x4.0m, 600hp, 12kts, 53p; 2x1-57/40, 2x1-47/40
	Alfredo	1	3	Alfredo	1896	No picture	40t, 18.3x3.7x1.8m, 11kts; 1x1-37/40
	Maceo	1	4	Maceo	1896	No picture	35t, 22.9x3.1x1.7m, 10kts; 1x1-37/40
	Enrique Villuendas	1	5	Enrique Villuendas	1899	No picture	178t, 40.2x6.1x2.7m, 600hp, 16kts; 2x1-47/40
	Matanzas	2	6,7	Matanzas, Las Villas	1912	No picture	80t, 30.5x5.5x1.3m, 1vte, 200hp, 12kts, 20p; 1x1-37/40
	Capitán Fernández Quevedo	1	8	Donativo	1932	No picture	130t, 30.8x5.5x2.1m, 2d, 300hp, 12kts, 21p; 2x1-37/40

© Ivan Gogin, 2012-15

[home](#)[World navies yesterday](#)[1935](#)

Czechoslovakia 01 January 1935

RIVER SHIPS

MONR	President Masaryk	1	1	President Masaryk	1932		230t, 50.0x6.0x1.1m, 2b,2gt, 2300hp, 18kts, 43p; 10belt, 5deck, 8turrets; 2x2-66/35, 10m
------	-------------------	---	---	-------------------	------	--	--

RIVER BOATS

YPR	OMh3	3	1-3	OMh3-5	1924		24t, 16.9x2.8x0.8m, 1pe, 100hp, 10.8kts, 9p
	OMs12	2	4, 5	OMs12, 13	1934		10t, 11.7x2.0x0.7m, 1d, 65hp, 13.5kts, 6p

MINE WARFARE BOATS

MLBR	Ms-5	2	1, 2	OMm33, 34	1920		24t, 16.9x2.8x0.8m, 1d, 100hp, 10.8kts, 6p; 7m
------	------	---	------	-----------	------	---	--

© Ivan Gogin, 2011-15



[home](#)[World navies yesterday](#)[1935](#)

Denmark 01 January 1935

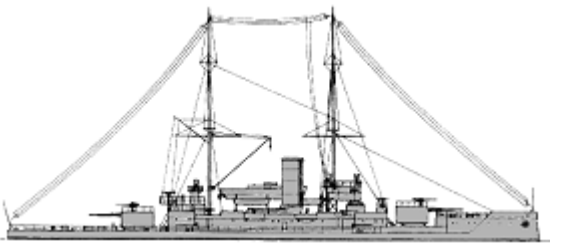
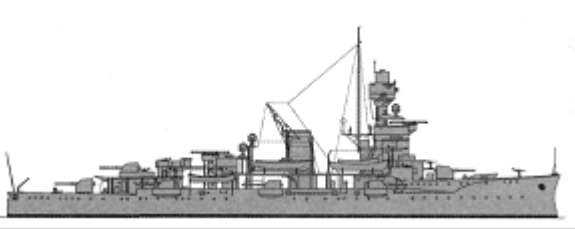
CAPITAL SHIPS



BC	Herluf Trolle	1	Olfert Fischer	1905		3700(1)-3785(2)t, 86.5(1)-87.4(2)x 15.4(1)-15.7(2)x5.0m, 6b,2vte, 4200(1)-5400(2)hp, 15.5(1)-16(2)kts, 258p; 195belt, 65deck, 190turrets, 190CT; 2x1-240/43, 4x1-150/43(1), 4x1-150/50(2), 6x1-75/55(1), 8x1-75/55(2), 2x1-57/44(1), 2x1-37/23, 2x2-20/60(2), 3-450TT(1), 4-450TT(2)
		2	Peder Skram	1908		
	Niels Iuel	1	Niels Iuel	1923		4100t, 90.0x16.3x5.0m, 4b,2vte, 5800hp, 16kts, 369p; 195belt, 55deck, 45shields, 170CT; 10x1-150/45, 4x1-57/55, 2-450TT

TORPEDO SHIPS

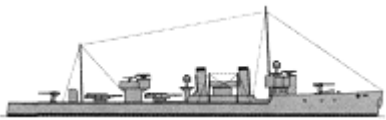
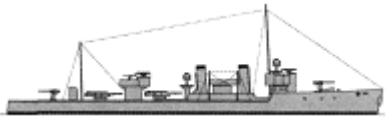

TB	Tumleren	1	Tumleren	1911		271t, 56.4x5.8x2.2m, 2b,1t, 5000hp, 27.5kts, 33p; 2x1-75/55, (1+4x1)-450TT	
		2	Vindhunden	1912			
		3	Spækhuggeren	1912			
	Søridderen	4	Søridderen	1911		295t, 55.4x5.5x2.0m, 2b,1t, 5000hp, 27.5kts, 33p; 2x1-75/55, (1+4x1)-450TT	
		5	Flyvefisken	1911			
		6	Sølven	1911			
	Springeren	4	7	Makrelen	1918		109t, 38.5x4.3x2.7m, 2b,1vte, 2000hp, 24.6kts, 24p; 2x1-57/44, (1+1x1)-450TT
			8	Nordkaperen	1918		
			9	Havkatten	1920		
			10	Sælen	1920		
	Dragen	3	11	Dragen	1930		335t, 61.0x6.0x2.3m, 2b,2gt, 6000hp, 27.5kts, 46p; 2x1-75/40, (2+2x3)-450TT
			12	Hvalen	1931		

						
		13	Laxen	1931		
Glenten	2	14	Glenten	1933		335t, 61.0x6.0x2.3m, 2b,2gt, 6000hp, 27.5kts, 51p; 2x1-87/50, (2+2x2)-450TT
		15	Høgen	1934		



SUBMARINES

SS	Ægir	3	1	Ran	1915		185/235t, 40.6x3.7x2.4m, 2d/2em(1), 450/340hp, 13.5/9.8kts, 11p; 1x1-57/44, 3-450TT
			2	Triton	1916		
			3	Galathea	1917		
	Rota	3	4	Rota	1920		301/369t, 47.5x4.8x2.7m, 2d/em, 900/640hp, 14.5/10.5kts, 17p; 1x1-57/44, 4-450TT
			5	Bellona	1921		
			6	Flora	1922		
Daphne	2	7	Daphne	1926		308/381t, 49.0x5.2x2.5m, 2d/em, 900/400hp, 13.4/6.8kts, 24p; 1x1-75/35, 1x1-20/60, 6-450TT	
		8	Dryaden	1927			

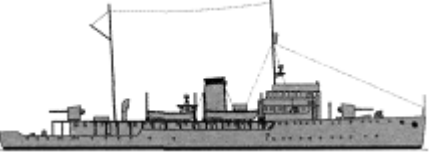
ESCORTS

PC	Hvalrossen	3	1	Hvalrossen	1913		182t, 45.2x5.2x2.1m, 2b,2vte, 3500hp, 26.3kts, 30p; 1x1-75/55, (1x2+1x1)-450TT
			2	Delfinen	1914		
			3	Sværdfisken	1914		
FPV	Beskytteren	1	1	Beskytteren	1900		415t, 43.4x7.6x3.8m, 2b,1vte, 625hp, 11kts, 47p; 1x1-57/44, 2x1-47/44
	Islands Falk	1	2	Islands Falk	1906	No picture	760t, 56.0x8.9x5.2m, 2b,1vte, 1100hp, 13kts, 63p; 2x1-75/55, 2x1-47/44
	Diana	1	3	Diana	1917	No picture	288t, 35.5x6.6x3.0m, 400hp, 10.5kts, 27p; 2x1-47/44
	Hvidbjørnen	1	4	Hvidbjørnen	1929		1050t, 63.2x9.7x5.2m, 1b,1vte, 1800hp, 14.5kts, 58p; 2x1-87/50, 1seaplane (MF.11)
	Maagen	1	5	Maagen	1932	No picture	110t, 21.8x5.4x2.9m, 1d, 120hp, 8kts, 11p; 1x1-37/23
	Ingolf	1	6	Ingolf	1934		1357t, 68.8x10.8x4.8m, 2b, 1vte, 2935hp, 16.2kts, 66p; 2x1-120/55, 2x1-57/44, 2x1-20/60, 1seaplane (MF.11)

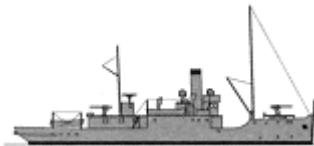
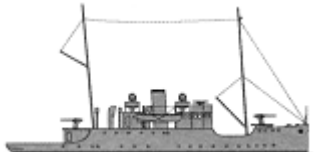
MINE WARFARE SHIPS

ML	Lossen	1	1	Lossen	1911		640t, 48.6x8.5x3.1m, 2b,2vte, 900hp, 13kts, 53p; 2x1-75/55, 180m
	Minekran Nr.V	2	2	Kvintus	1917	No picture	186t, 27.0x6.3x2.0m, 2dg, 2em, 290hp, 26p; 2x1-37/38, 60m
			3	Sixtus	1919		
	Henrik Gerner	1	4	Henrik Gerner	1928		463t, 49.0x6.2x2.4m, 2d, 900hp, 13.2kts, 45p; 2x1-75/55, 80m
MS	Springeren	6	1	Springeren	1917		109t, 38.5x4.3x2.7m, 2b,1vte, 2000hp, 24.6kts, 24p; 2x1-57/44, 1-450TT, MS
			2	Støren	1917		
			3	Søløven	1917		
			4	Søhunden	1917		
			5	Havhesten	1917		
			6	Narhvalen	1917		

[home](#)

[World navies yesterday](#)

[1935](#)

Dominican Republic 01 January 1935

COASTAL FORCES

YP	GC1	2	1,2	GC1,3	1924	No picture	37t, 22.9x4.2x1.2m, 1pe, 400hp, 13.5kts, 12p
	GC2	1	3	GC2	1918	No picture	18t, 13.7x3.4x1.1m, 2pe, 200hp, 9.5kts

© Ivan Gogin, 2012-15

[home](#)[World navies yesterday](#)[1935](#)

Ecuador 01 January 1935

OTHER FIGHTING SHIPS

APG	-	1	1	Cotopaxi	1884		300t; 4x1-76/40
DV	Atahualpa	1	1	Atahualpa	1927	No picture	100t, 1vte; 1x1-47/40

© Ivan Gogin, 2012-15

[home](#)[World navies yesterday](#)[1935](#)

Egypt 01 January 1935

ESCORTS

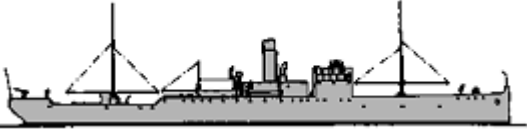
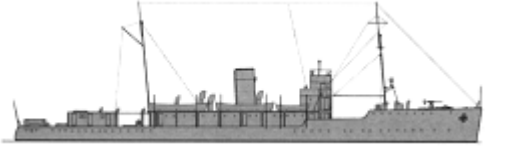
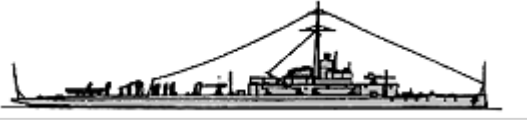
SL	Sollum	1	1	Sollum	1917		1493t, 80.0x10.7x3.5m, 2b,1vte, 2500hp, 17.5kts, 77p; 1x1-76/40
	El Amir Farouq	1	2	El Amir Farouq	1926		1441t, 75.3x10.4x4.0m, 2b,2vte, 2800hp, 17kts, 70p; 1x1-57/40
FS	Raqib	1	1	Raqib	1917		613t, 74.5x7.2x2.4m, 2b,2t, 3500hp, 20kts, 54p; 1x1-102/40, 1x1-40/39, 2x1-356TT, 2DCR

OTHER FIGHTING SHIPS

PGR	Tamai	2	1, 2	Hafir, Abu Klea	1884-1885	No picture	74t, sw; 1x1-76/40
	El Zafir	2	3	El Zafir	1896/97	No picture	128t, sw; 1x1-76/40
			4	El Fateh	1896/97		
	Sheik	1	5	Melik	1896/97	No picture	140t, 1vte; 1x1-76/40

COASTAL FORCES

YP	Darfeel	2	1, 2	Darfeel, Noor El Bahr	1925	No picture	20t, 17.1xxm, 330hp, 17kts; 1x1-37/37
----	---------	---	------	-----------------------	------	------------	---------------------------------------

[home](#)[World navies yesterday](#)[1935](#)

Estonia 01 January 1935





TORPEDO SHIPS

TB	Sulev	1	1	Sulev	1916		286t, 50.0x5.3x2.3m, 1b,1gt, 3250hp, 24kts, 35p; 2x1-75/50, 1x2-450TT, 10m
----	-------	---	---	-------	------	---	--

OTHER FIGHTING SHIPS

PG	Laine	1	1	Laine	1913		211t, 37.0x6.1x1.8m, 1b,1vte, 500hp, 12kts, 20p; 2x1-76/30
APGR	-	4	1	Ahti	1908		115t
			2	Mardus	1911		150t; 2x1-75/50
			3	Tartu	1897		110t
			4	Wanemune	1914		200t; 2x1-75/50

MINE WARFARE SHIPS

AML	-	2	1	Ristna	1906		600t; 175m
			2	Suurop	1906		600t; 175m
MSB	Kalev	1	1	Kalev	1914		34t, 20.7x5.0x1.2m, 2sd, 60hp, 7.2kts, 8p; 25m, MS
	Olev	1	2	Olev	1916		46t, 23.2x5.0x1.1m, 2sd, 60hp, 7.2kts, 8p; 40m, MS

BOARD GUARD SHIPS

ABGS	-	1	1	Kou	1909		100t
------	---	---	---	-----	------	--	------

© Ivan Gogin, 2011-15



[home](#)[World navies yesterday](#)[1935](#)

Finland 01 January 1935

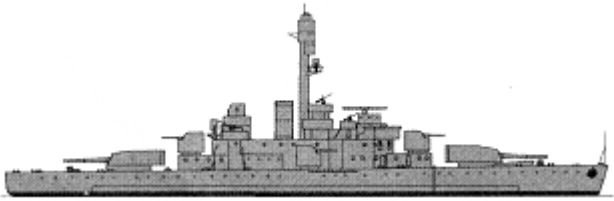
CAPITAL SHIPS

BC	Väinämöinen	2	1	Väinämöinen	1932		~4200t, 95.0x16.9x4.5m, 4dg,2em, 6000hp, 15kts, 330p; 55belt, 20deck, 100turrets, 120CT; 2x2-254/45, 4x2-105/50, 4x1-40/39, 2x1-20/60
			2	Ilmarinen	1933		

SUBMARINES

SS	Vetehinen	3	1	Vetehinen	1930		600/716t, 63.5x6.1x3.5m, 2d/em, 1160/700hp, 13.5/8.5kts, 29p, 75m; 1x1-76/48, 1x1-20/60, 4-533TT, 20m
			2	Vesihiihi	1930		
			3	Iku-Turso	1931		
	Saukko	1	4	Saukko	1930		130/140t, 32.4x4.1x2.9m, 1d/em, 170/120hp, 7/5.7kts, 15p, 75m; 1x1-12.7, 2-450TT, 9m
	Vesikko	1	5	Vesikko	1934		254/303t, 40.9x4.1x3.8m, 2d/em, 700/360hp, 13.1/8.1kts, 19p, 90m; 1x1-20/60, 5-450TT

ESCORTS

PC	Klas Horn	2	1	Klas Horn	1892		432t, 60.2x7.4x3.3m, 2b,1vte, 3500hp, 22kts, 65p; 2x1-102/60(1), 2x1-75/50(2)
			2	Matti Kurki	1892		

OTHER FIGHTING SHIPS





	Karjala	2	1	Karjala	1918		342t, 50.1x6.8x2.3m, 2b,2vte, 1150hp, 15kts, 48p; 2x1-75/50, 1x1-40/39, 30m
			2	Turunmaa	1918		

PG	Hämeenmaa	2	3	Hämeenmaa	1918		530t, 52.0x7.5x3.4m, 3b,2vte, 1400hp, 15kts, 55p; 2x1-102/60, 1x1-40/39
			4	Uusimaa	1918		

COASTAL FORCES

PT	MTV1	2	1, 2	MTV1, 2	1918		13t, 16.4x2.8x1.4m, 2pe/em, 500/10hp, 26.5kts, 8p; 2-450TT
	MTV3	1	3	MTV3	1926		11t, 16.6x3.4x1.1m, 2pe, 600hp, 31kts, 5p; 2-450TT
	MTV4	4	4-7	MTV4-7	1928-1929		12t, 16.8x3.4x1.0m, 2pe/1pe(2), 750/25hp, 40kts, 7p; 2-450TT
YP	VMV1	2	1, 2	VMV1, 2	1930	No picture	30t, 23.5x4.2x1.0m, 2pe/1pe(2), 1120/100hp, 25kts, 8p; 1x1-20/60
	VMV5	2	3, 4	VMV5, 6	1931	No picture	30t, 24.6x4.4x1.1m, 2pe/1pe(2), 900/140hp, 24.6kts, 8p; 1x1-20/60

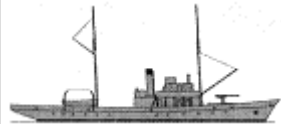
MINE WARFARE SHIPS AND CRAFTS

ML	M1	1	1	M1	1916		776t, 50.0x8.0x2.7m, 3b,1vte, 800hp, 12kts, 46p; 2x1-75/50, 150m
MLB	T15	3	1-3	T15, 16, 21	1914		60t, 20.7x5.0x1.2m, 2sd, 60hp, 7.2kts, 8p; 30m
	T17	2	4, 5	T17, 22	1916		80t, 23.2x5.0x1.1m, 2sd, 60hp, 7.2kts, 8p; 45m
MS	T1	2	1	T1	1918		220t, 43.6x6.1x1.7m, 2b,2vte, 400hp, 11kts, 35p; 1x1-75/50, 1x1-47/43, MS
			2	T2	1917		
MSB	A8	16	1-16	A11, 12, 19-21, 37-45, MP1, 5	1916 - 1917	No picture	20t, 19.8x3.6x1.2m, 1pe, 10kts; MS
	AF1	1	17	AF2	1917/18		25t, 15.3x3.5xm, 1pe, 50hp, 9kts, 8p; MS
	BVA	4	18-21	BVA, BVB, BVC, BVD	1910		25t, 22.2x3.1x0.5m, 2pe, 200hp, 14.5kts, 12p; 8belt, 8deck, 8CT; 1x1-76/16, MS

[home](#)[World navies yesterday](#)[1935](#)

France 01 January 1935

IN SERVICE: 2 battleships-predreadnoughts, 6 battleships, 1 fleet aircraft carrier, 1 seaplane tender, 2 armoured cruisers, 7 heavy cruisers, 4 light cruisers, 1 training cruiser, 1 cruiser-minelayer, 68 destroyers, 2 torpedo boats, 90 submarines, 11 sloops, 51 fast patrol ships, 30 submarine chasers, 40 patrol trawlers and tugs, 8 river gunboats, 7 motor torpedo boats, 2 auxiliary minelayers, 8 minesweepers

CAPITAL SHIPS

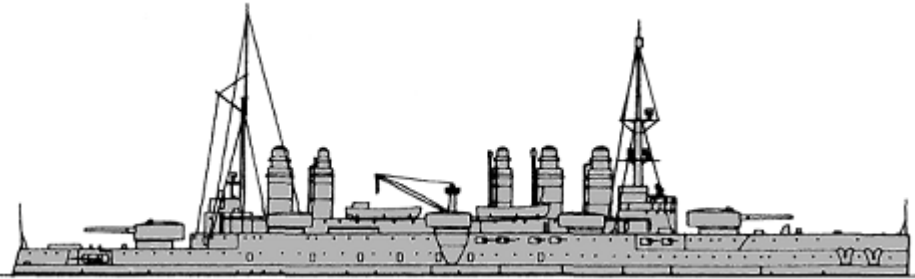
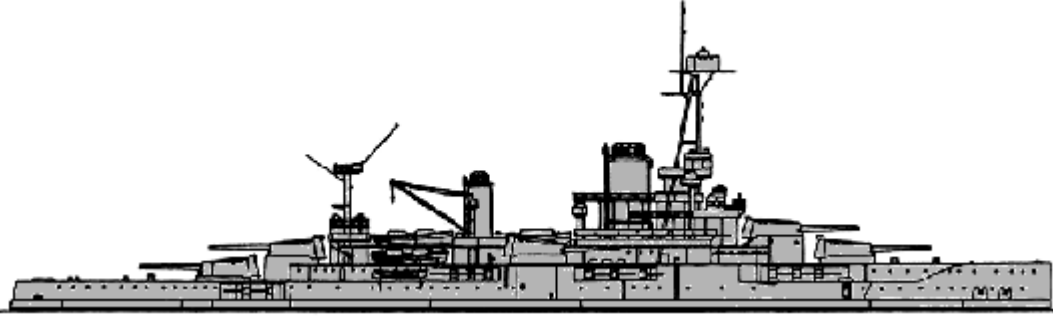
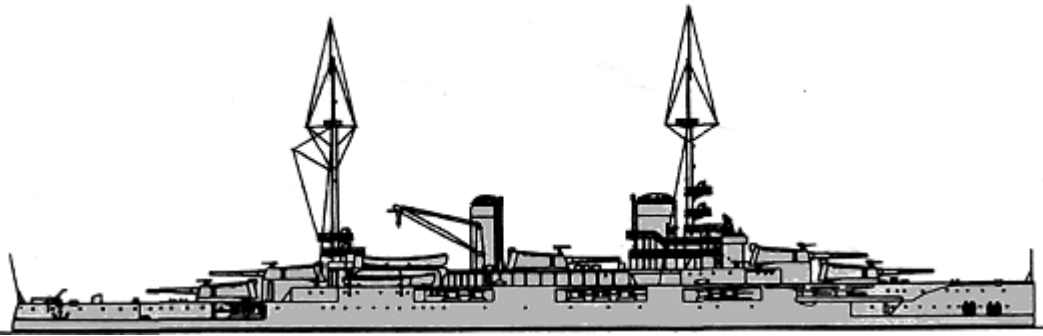
BB	Danton	1	Diderot (TS)	1911		19763t, 146.6x25.8x9.2m, 26b,4t, 22500hp, 19.2kts, 921p; 270belt, (48+45)deck, 300turrets, 300CT; 2x2-305/45, 6x2-240/50, 28x1-75/65, 10x1-47/50, 2-450TT
		2	Voltaire (TS)	1911		
	Courbet	3	Courbet	1913		26000t, 168.0x27.9x9.0m, 26b,4gt(3)-4t(4,5), 28000hp, 20kts, 1108p; 270belt, (70+40)deck, 320turrets, 300CT; 6x2-305/45, 22x1-139/55, 4x1-75/50, 4x1-47/50, 4-450TT
		4	Jean Bart	1913		
		5	Paris	1914		
	Bretagne	6	Bretagne	1915		25000t, 166.0x26.9x9.8m, 6b,4gt, 43000hp, 21.4kts, 1133p; 250belt, (45+40)deck, 400-250turrets, 300CT; 5x2-340/45, 14x1-139/55(6,7), 18x1-139/55(8), 8x1-75/50(6,7), 4x1-75/65(8), 4x1-47/50, 4x1-37/50(6,7), 2x4-13.2(6,7), 4-450TT(8), 30m(8)
		7	Provence	1915		
		8	Lorraine	1916		

AIRCRAFT CARRYING SHIPS

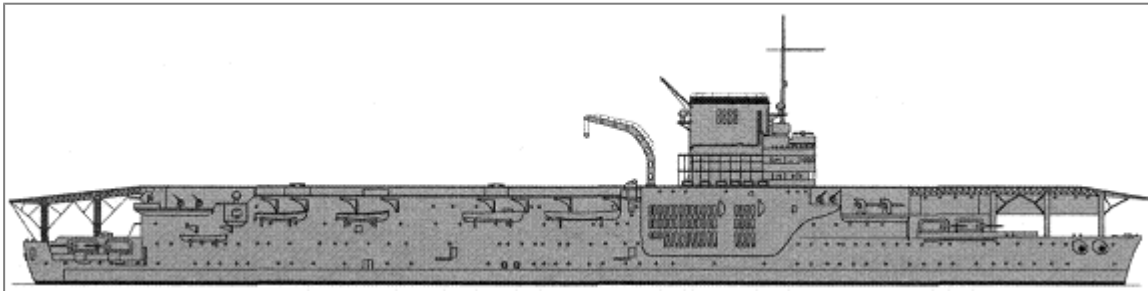
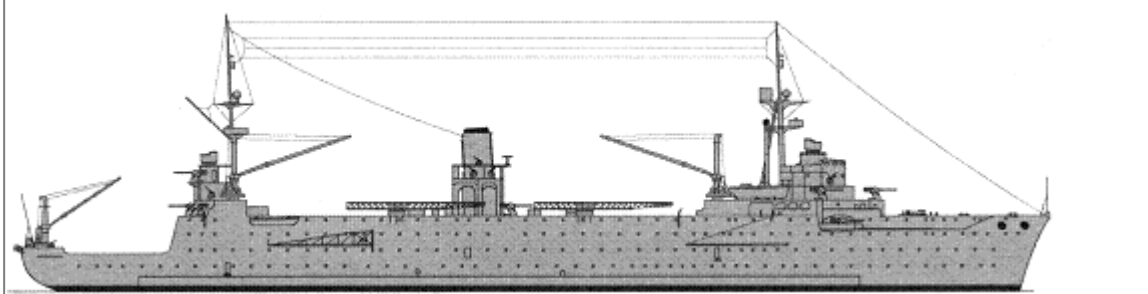

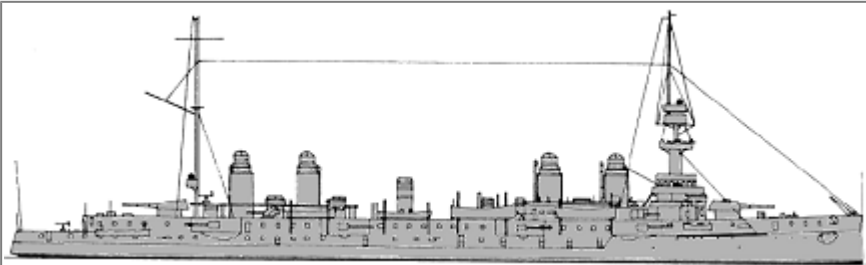
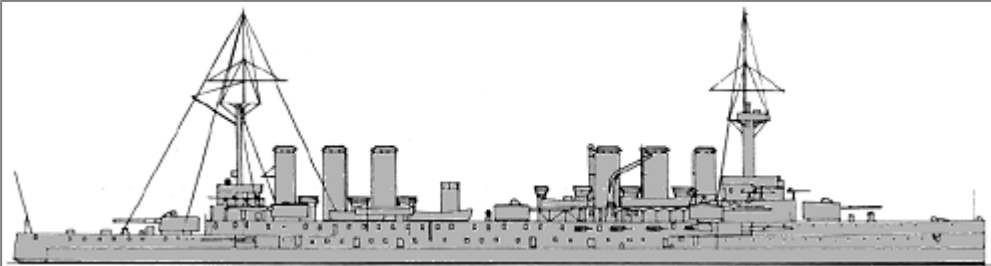
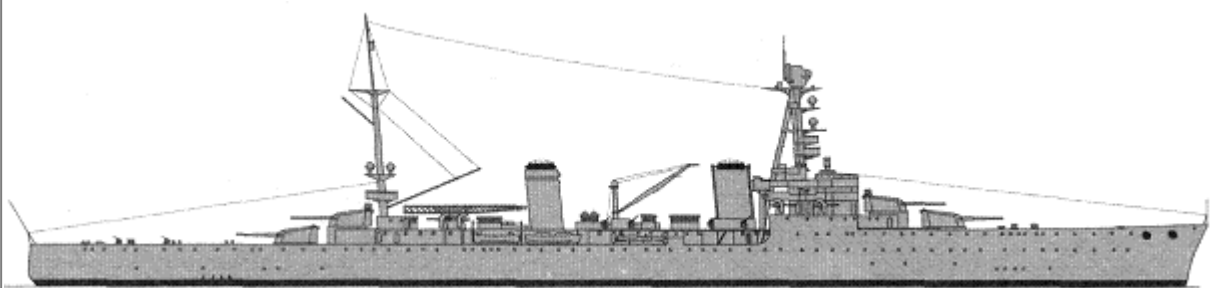

CV	Béarn	1	1	Béarn	1927		28400t, 182.6x31.0x9.3m, 6b,2t,2vte(4), 37500hp, 21.5kts, 865p; 80belt, (24+24+60)deck, 70casemates; 8x1-155/50, 6x1-75/50, 4-550TT, 40aircraft (20 Wib.74, 5 P.L.7)
AV	Commandant Teste	1	1	Commandant Teste	1932		11500t, 167.0x27.0x6.9m, 4b,2gt, 21000hp, 20.5kts, 644p; 50belt, 36deck, 80CT; 12x1-100/45, 8x1-37/50, 6x2-13.2, 26seaplanes (14 CAMS.37, 12 PL.15)

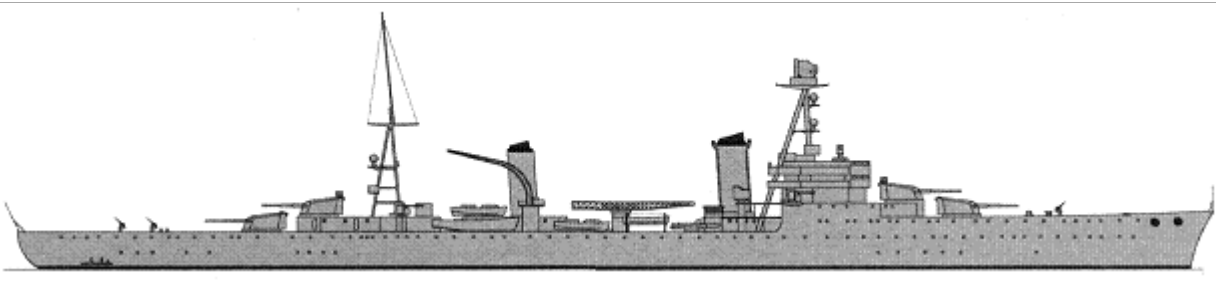
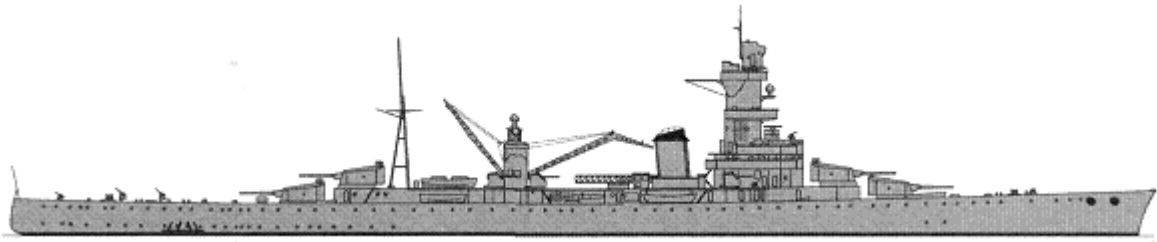
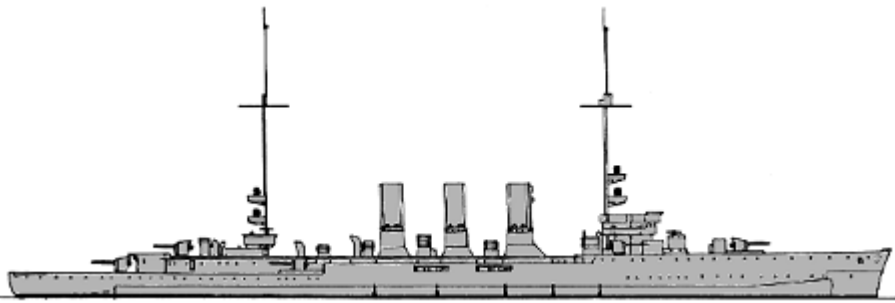
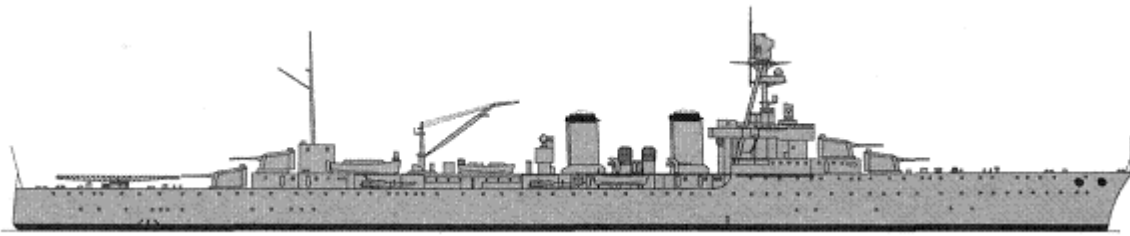
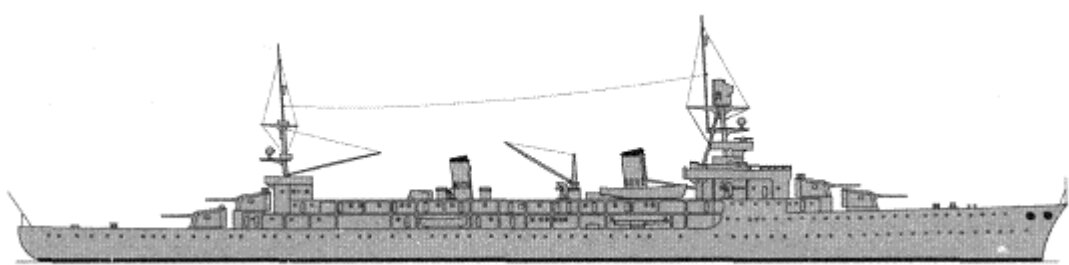
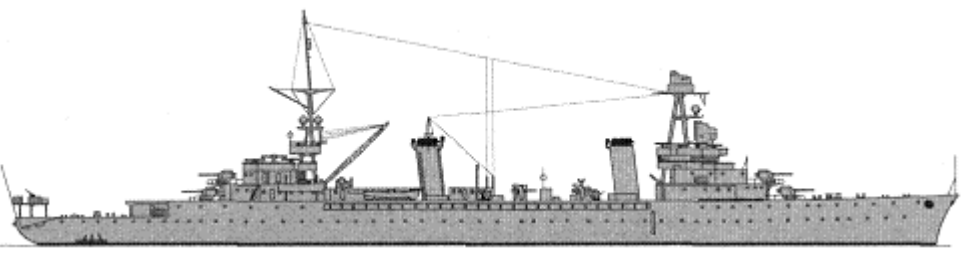
CRUISERS

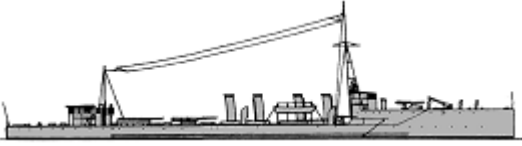
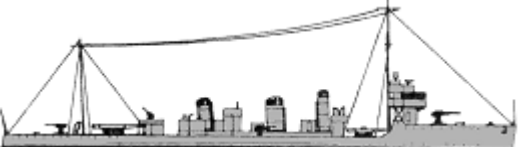
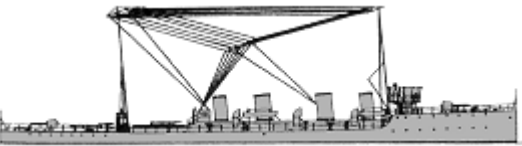

	Gueydon	1	1	Gueydon (TS)	1903		9548t, 138.0x19.4x7.7m, 28b,3vte, 19600hp, 21kts, 566p; h: 150belt, 55deck, 200turrets, 160CT; 2x1-194/40, 8x1-164/45, 4x1-100/45, 16x1-47/40, 4x1-37/23, 2-450TT
	Edgar Quinet	1	2	Waldeck-Rousseau	1911		13995t, 158.9x221.5x8.4m, 42b,3vte, 36000hp, 23kts, 892p; 150belt, (65+35)deck, 200turrets, 200CT; (2x2+10x1)-194/50, 22x1-65/50, 4x1-47/50, 2-450TT, 1 seaplane (CAMS.37)
CA	Duquesne	2	3	Duquesne	1927		12200t, 191.0x19.0x6.3m, 9b,4gt, 120000hp, 33.7kts, 605p; 30magazines, 24deck, 30turrets, 30CT; 4x2-203/50, 8x1-75/50, 8x1-37/50, 2x3-550TT, 1seaplane (CAMS.37)
			4	Tourville	1928		
			5	Suffren	1930		
			6	Colbert	1931		
							12928(5)-13103(6)-13429(7)-13407(8)t, 196.0(5)-194.2(6,7)-194.0(8) x20.0(5)-19.4(6)-19.3(7,8)

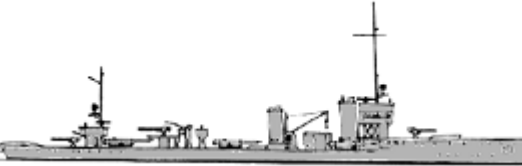
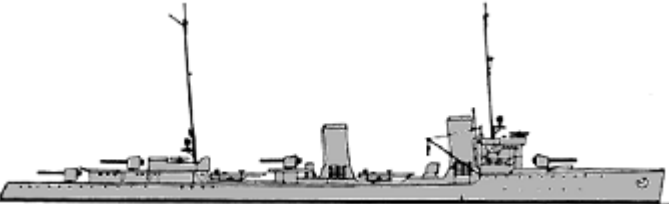
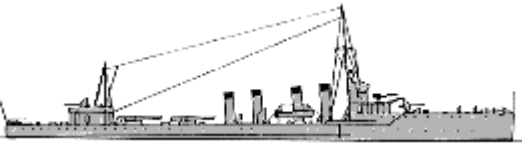
	Suffren	4	7 Foch	1931		x7.3(5,6)-7.5(7)-7.2(8)m, 8b(5,6)-6b(7,8),3gt, 90000hp, 32kts, 605p; 50belt(5,6)-54(7)-60(8)torpedo bulkhead, (25+18)(5)-(22+18)(6)-(22+30)(7,8)deck, 30turrets, 30CT; 4x2-203/50, 8x1-90/50(6,7), 4x2-90/50(8), 8x1-75/50(5), 8x1-37/50(5), 6x1-37/50(6-8), 4x4-13.2(8), 2x3-550TT, 2seaplanes (GL.810(5)), 3seaplanes (GL.810(6-8))
	Algérie	1	9 Algérie	1934		13461t, 186.2x20.0x6.2m, 6b,4gt, 84000hp, 31kts, 616p; 110belt, 80deck, 100turrets, 100CT; 4x2-203/55, 6x2-100/45, 4x1-37/50, 4x4-13.2, 2x3-550TT, 3seaplanes (GL.812)
CL	Strasbourg	1	1 Strasbourg	1915		6382t, 142.7x13.8x5.8m, 12b,2t, 29000hp, 28kts, 385p; 60belt, 40deck, 50shields, 100CT; 7x1-150/45, 2x1-88/45, 4x1-500TT, 120m
	Duguay Trouin	2	Duguay Trouin	1926		9350t, 181.6x17.2x5.2m, 8b,4gt, 100000hp, 33kts, 578p; 20magazines, 20deck, 25turrets, 25CT; 4x2-155/50, 4x1-75/50, 6x2-13.2, 4x3-550TT, 2seaplanes (GL.810)
		3	Lamotte-Picquet	1926		
4		Primaguet	1926			
CT	Jeanne d'Arc	1	1 Jeanne d'Arc	1931		8950t, 170.0x17.7x6.4m, 4b,2gt, 32500hp, 25kts, 506p+176; 20magazines, 25turrets, 25CT; 4x2-155/50, 4x1-75/50, 2x1-37/50, 2x1-550TT, 2seaplanes (CAMS.37)
CM	Pluton	1	1 Pluton	1931		6500t, 152.5x15.6x5.2m, 4b,2gt, 57000hp, 30kts, 424p; 20shields; 4x1-139/40, 4x1-75/50, 2x1-47/40, 2x1-37/50, 6x2-13.2, 290m



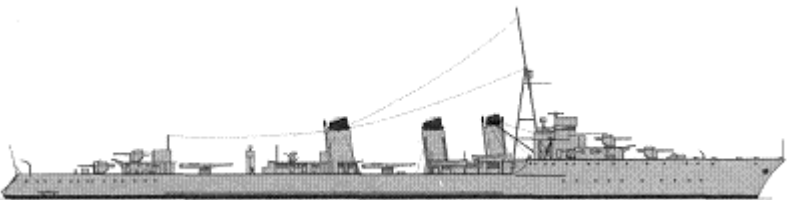
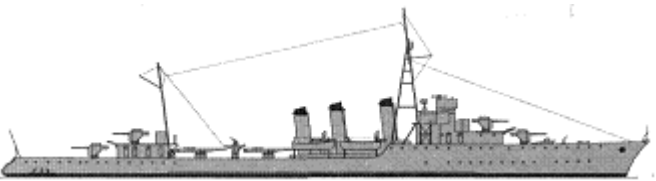
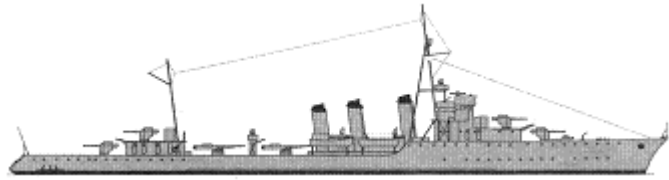
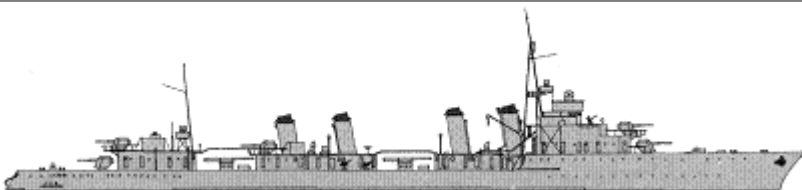
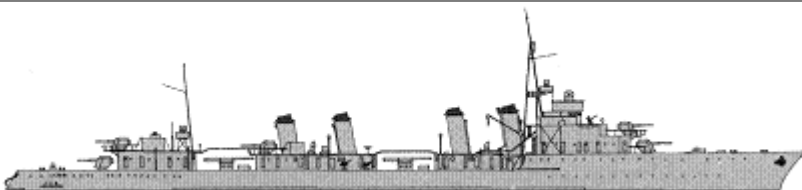

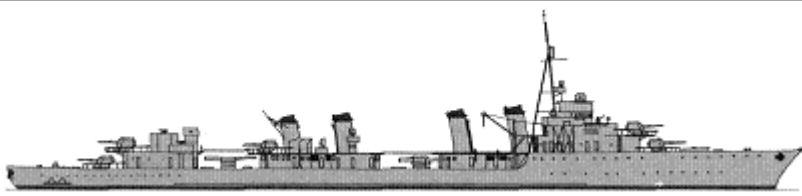
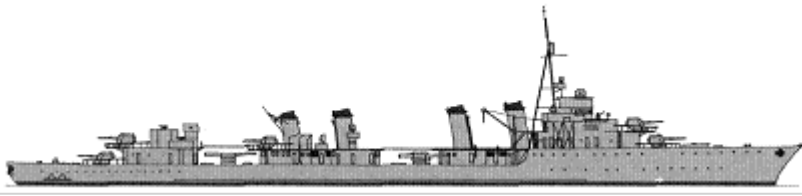
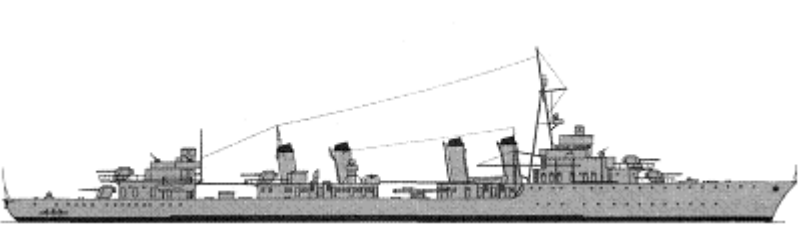
TORPEDO SHIPS







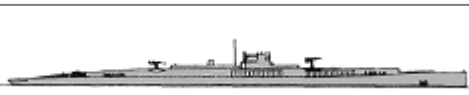
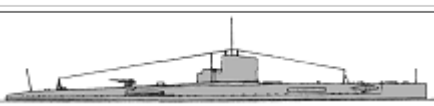

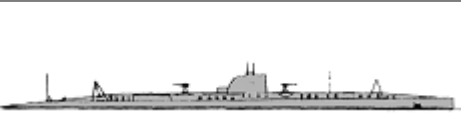

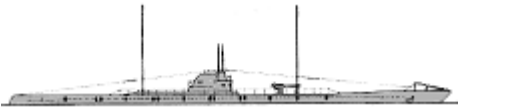

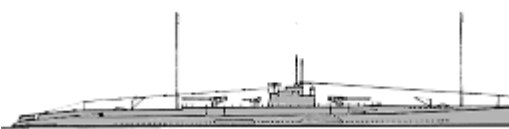
Enseigne Roux	2	1	Enseigne Roux	1916		1075t, 82.6x8.6x3.0m, 4b,2t, 17000hp, 30kts, 81p; 2x1-100/45, 1x1-75/35, 4x1-65/50, 2x2-450TT, 2DCR
		2	Mécanicien Principal Lestin	1916		
Arabe	10	3	Algérien	1917		750t, 83.0x7.3x2.4m, 4b,2vte, 10000hp, 29kts, 86p; 1x1-120/40, 4x1-76/40, 2x2-450TT
		4	Arabe	1917		
		5	Hova	1917		
		6	Kabyle	1917		
		7	Marocain	1917		
		8	Sakalave	1917		
		9	Sénégalais	1917		
		10	Somali	1917		
		11	Tonkinois	1917		
		12	Touareg	1917		
Matelot Leblanc	1	13	Matelot Leblanc	1917		1045t, 85.4x7.8x2.4m, 6b,2t, 22360hp, 32.6kts, 114p; 2x1-100/50, 6x1-66/50, 2x2-450TT
Chastang	2	14	Vesco	1918		1170t, 83.1x8.3x3.6m, 3b,2t, 24000hp, 32kts, 105p; 3x1-105/45, (2x2+2x1)-500TT, 24m
		15	Mazaré	1918		
Rageot de la Touche	1	16	Rageot de la Touche	1918		1147t, 84.5x8.4x3.4m, 3b,2t/1t(2), 24500hp, 32kts, 105p; 3x1-105/45, (2x2+2x1)-500TT, 24m
Amiral Sénès	1	17	Amiral Sénès	1919		2415t, 106.0x10.2x3.4m, 4b,2t, 45000hp, 36kts, 188p; 4x1-150/45, 2x2-600TT, 40m
Enseigne Gabolde	1	18	Enseigne Gabolde	1923		950t, 83.6x8.2x3.1m, 4b,2gt, 20000hp, 31kts, 80p; 3x1-100/45, 1x1-75/35, 2x2-500TT, 2DCR
Chacal	6	19	Tigre	1925		3050t, 126.8x11.3x4.1m, 5b,2gt, 50000hp, 35.5kts, 195p; 5x1-130/40, 2x1-75/50, 2x3-550TT, 4DCT, 2DCR
		20	Jaguar	1926		
		21	Chacal	1926		
		22	Panthère	1926		
		23	Lynx	1927		

DD							
		24	Léopard	1927			
	Bourrasque	12	25	Simoun	1926		1900t, 105.8x9.6x4.3m, 3b,2gt, 33000hp, 33kts, 142p; 4x1-130/40, 2x1-37/50, 2x2-13.2, 2x3-550TT, 2DCT, 2DCR
			26	Orage	1926		
			27	Tempête	1926		
			28	Bourrasque	1926		
			29	Tramontane	1927		
			30	Ouragan	1927		
			31	Mistral	1927		
			32	Siroco	1927		
			33	Trombe	1927		
			34	Typhon	1928		
			35	Cyclone	1928		
			36	Tornade	1928		
	L'Adroit	14	37	La Palme	1928		2000t, 107.2x9.8x4.3m, 3b,2gt, 34000hp, 33kts, 142p; 4x1-130/40, 1x1-75/50, 2x3-550TT, 2DCT, 2DCR
38			Le Mars	1928			
39			La Railleuse	1928			
40			Le Fortune	1928			
41			Brestois	1928			
42			Boulonnais	1928			
43			L'Alcyon	1929			
44			L'Adroit	1929			
45			Le Bordelais	1930			
46			Forbin	1930			
47			Fougueux	1930			
48			Le Foudroyant	1930			
49			Basque	1931			
50			Frondeur	1931			
Guépard	2	51	Guépard	1929		3200t, 130.2x11.8x4.7m, 4b,2gt, 64000hp, 35.5kts, 230p; 5x1-139/40, 4x1-37/50, 2x2-13.2, 2x3-550TT, 2DCR	
		52	Bison	1930			
Valmy	4	53	Valmy	1930		3200t, 130.2x11.8x4.7m, 4b,2gt, 64000hp, 35.5kts, 230p; 5x1-139/40, 4x1-37/50, 2x2-13.2, 2x3-550TT, 2DCR	
		54	Verdun	1930			
		55	Lion	1931			
		56	Vauban	1931			

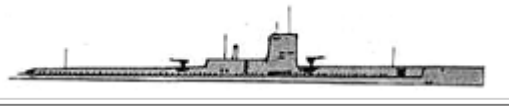

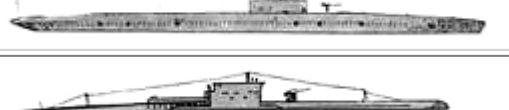



Aigle	4	57	Aigle	1932		3410t, 128.5x11.8x5.0m, 4b,2gt, 64000hp, 36kts, 230p; 5x1-139/40, 4x1-37/50, 2x2-13.2, 2x3-550TT, 4DCT, 2DCR
		58	Gerfaut	1932		
		59	Albatros	1932		
		60	Vautour	1932		
Épervier	2	61	Épervier	1934		3410t, 129.3x11.8x5.0m, 4b,2gt, 68000hp, 36kts, 230p; 5x1-139/40, 4x1-37/50, 2x2-13.2, (1x3+2x2)-500TT, 4DCT, 2DCR, 20m
		62	Milan	1934		
Vauquelin	6	63	Cassard	1933		3140t, 129.3x11.8x5.0m, 4b,2gt, 64000hp, 36kts, 230p; 5x1-139/40, 4x1-37/50, 2x2-13.2, (1x3+2x2)-500TT, 4DCT, 2DCR, 50m
		64	Tartu	1933		
		65	Vauquelin	1934		
		66	Maillé Brézé	1934		
		67	Kersaint	1934		
		68	Chevalier Paul	1934		
TB No295	2	1	No349	1906		101t, 38.0x4.4x1.9m, 2b,1vte, 2000hp, 26kts, 23p; 1x1-75/35, 2x5-37/20, 1-450TT
		2	No369	1908		

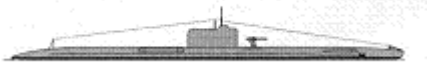

SUBMARINES

Gustave Zédé	2	1	Gustave Zédé	1914		849(1)-820(2)/1098(1)-1047(2)t, 74.0x6.0x3.7m, 2d/em, 2400/1640hp, 15(1)-17.3(2)/11.4(1)-10.5(2)kts, 47p; 1x1-75/35, 1x1-47/50, 8-450TT(1), (8+1x2)-450TT(2)
		2	Néréide	1916		
Amphitrite	1	3	Amphitrite II	1915		414/609t, 53.9x5.4x3.3m, 2d/em, 800/700hp, (12-13)/9.5kts, 29p; 1x1-75/35, 8-450TT
Bellone	3	4	Bellone	1916		523/788t, 60.6x5.4x3.5m, 2d/em, 1640/800hp, 14.7/9.5kts, 38p; 1x1-75/35, 8-450TT
		5	Gorgone	1916		
		6	Hermione	1917		
Dupuy de Lôme	2	7	Dupuy de Lôme	1916		833/1287t, 75.0x6.4x3.6m, 2d/em, 2400/1640hp, 15/11kts, 43p; 1x1-75/35, 1x1-47/50, 8-450TT
		8	Sané	1916		
Diane	1	9	Daphné	1916		633/891t, 68.0x5.5x3.7m, 2d/em, 1800/1400hp, 17/11.5kts, 43p; 1x1-75/35, 10-450TT
Armide	1	10	Antigone	1917		457/670t, 56.2x5.2x3.0m, 2d/em, 2200/900hp, 17.5/11kts, 31p; 1x1-47/50, 4-450TT
Lagrange	4	11	Lagrange	1918		920/1318t, 75.2x6.3x3.6m, 2d/em, 2600/1640hp, 16.5/11kts, 47p; 2x1-75/35, 8-450TT
		12	Romazotti	1918		
		13	Laplace	1921		
		14	Regnault	1924		
Victor	1	15	Victor	1916		755/832t, 56.8x5.9x4.9m, 2d/em, 900/800hp, 9.9/7.8kts, 32p, 50m; 1x1-105/45, 2-500TT, 38m

			Réveille				
	Jean Autric	2	16 Jean Autric	1917		798/1000t, 71.6x6.3x3.9m, 2d/em, 2400/1200hp, 16.4/8.4kts, 36p, 50m; 1x1-105/45, 1x1-88/30, 6-500TT	
			17 Léon Mignot	1917			
	René Audry	1	18 René Audry	1918		1164/1512t, 81.5x7.4x4.2m, 2d/em, 2400/1200hp, 14.7/7kts, 40p, 75m; 1x1-150/45, 4-500TT, 72m	
	Halbronn	1	19 Halbronn	1918		1930/2483t, 92.0x9.1x5.3m, 2d+1dg/2em(2), (3500+450)/1780hp, 15.8/7.6kts, 62p, 75m; 60CT; 2x1-150/45, 6-500TT	
	Pierre Marrast	2	20 Pierre Marrast	1918		821/1002t, 71.6x6.3x3.9m, 2d/em, 2400/1230hp, 16.2/8.2kts, 39p, 50m; 1x1-105/45, 6-500TT	
				21 Jean Roulier			1919
	Trinité-Schillemans	2	22 Trinité-Schillemans	1918		510/640t, 55.5x5.8x3.7m, 2d/em, 1100/788hp, 13/7.4kts, 34p, 75m; 1x1-105/45, 5-500TT	
				23 Carrisan			1918
	Jean Corre	1	24 Jean Corre	1919		539/656t, 55.5x5.8x3.9m, 2d/em, 1060/788hp, 13.5/7.5kts, 34p, 75m; 1x1-105/45, 5-500TT	
	Fulton	2	25 Fulton	1920		870/1247t, 74.0x6.4x3.6m, 2d/em, 2700/1640hp, 16.5/11kts, 47p; 2x1-75/35, 8-450TT	
				26 Joessel			1920
	O`Byrne	2	27 O`Byrne	1921		342/513t, 52.4x4.7x2.7m, 2d/em, 1020/400hp, 14/8kts, 25p; 1x1-47/50, 4-450TT	
				28 Henry Fournier			1921
	Maurice Callot	1	29 Maurice Callot	1922		931/1298t, 75.5x6.7x3.5m, 2d/em, 2900/1640hp, 16.5/10.5kts, 48p; 1x1-75/35, 6-450TT, 27m	
	Pierre Chailley	1	30 Pierre Chailley	1922		884/1191t, 70.0x7.5x4.0m, 2d/em, 1800/1400hp, 13.7/8.5kts, 44p; 1x1-100/45, 4-450TT, 40m	
	Requin	9	31 Requin	1926		1150/1441t, 78.3x6.8x5.1m, 2d/em, 2900/1800hp, 15/9kts, 51p, 80m; 1x1-100/45, (6+2x2)-550TT	
				32 Souffleur			1926
				33 Narval			1926
				34 Marsouin			1927
				35 Dauphin			1927
				36 Espadon			1927
				37 Caïman			1927
				38 Morse			1928
				39 Phoque			1928
	Sirène	4	40 Sirène	1927		609/757t, 64.0x5.2x4.3m, 2d/em, 1300/1000hp, 14/7.5kts, 41p, 80m; 1x1-75/35, (5+1x2)-550TT	
				41 Naiade			1927
				42 Galathée			1927

SS



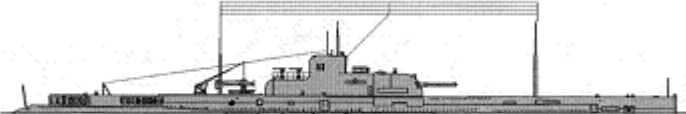

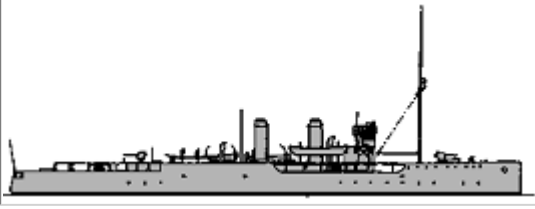
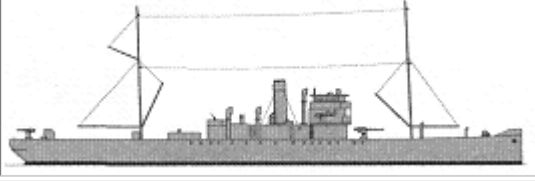
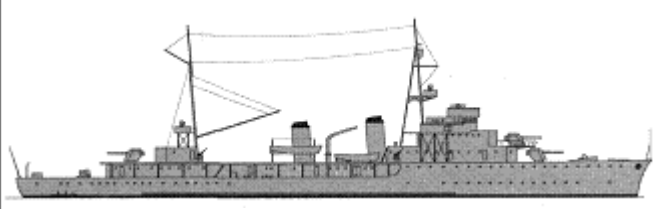
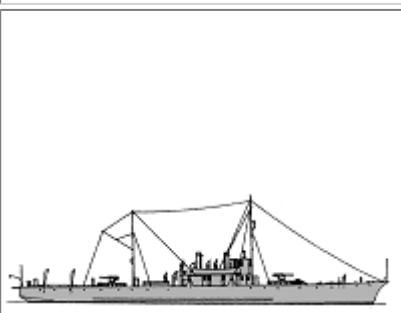

						
		43	Nymphé	1927		
Ariane	3	44	Ariane	1929		626/787t, 66.0x6.2x4.1m, 2d/em, 1250/1000hp, 14/7.5kts, 41p, 80m; 1x1-100/45, (5+1x2)-550TT
		45	Eurydice	1929		
		46	Danaé	1929		
Circé	4	47	Circé	1929		615/776t, 62.5x6.2x4.0m, 2d/em, 1250/1000hp, 14/7.5kts, 41p, 80m; 1x1-75/35, (5+1x2)-550TT
		48	Calypso	1929		
		49	Thétis	1929		
		50	Doris	1930		
Saphir	4	51	Saphir	1930		761/925t, 65.9x7.2x4.3m, 2d/em, 1300/1000hp, 12/9kts, 42p, 80m; 1x1-75/35, 1x2-13.2, 2-550TT, 1x(1-550+2-400)TT, 32m
		52	Turquoise	1930		
		53	Rubis	1933		
		54	Diamant	1934		
Redoutable	18	55	Redoutable	1931		1570/2084t, 92.3x8.2x4.7m, 2d/em, 6000/2000hp, 17/10kts, 61p, 80m; 1x1-100/45, 1x2-13.2, (4+1x3)-550TT, 1x(2-550+2-400)TT
		56	Vengeur	1931		
		57	Fresnel	1931		
		58	Henri Poincaré	1931		
		59	Pascal	1931		
		60	Actéon	1931		
		61	Archimède	1932		
		62	Monge	1932		
		63	Pasteur	1932		
		64	Poncelet	1932		
		65	Achéron	1932		
		66	Protée	1932		
		67	Pégase	1932		
		68	Phénix	1932		
		69	Achille	1933		
70	Argo	1933				
71	Ajax	1934				
72	Persée	1934				
L'Espoire	2	73	L'Espoire	1934		1570/2084t, 92.3x8.2x4.7m, 2d/em, 7200/2000hp, 19/10kts, 61p, 80m; 1x1-100/45, 1x2-13.2, (4+1x3)-550TT, 1x(2-550+2-400)TT
		74	Le Glorieux	1934		
Argonaute	4	75	Argonaute	1932		630/798t, 63.4x6.4x4.2m, 2d/em, 1300/1000hp, 14/9kts, 41p, 80m; 1x1-75/35, (4+1x2)-550TT, 1x2-400TT
		76	Aréthuse	1933		
		77	Atalante	1934		
		78	La Vestale	1934		

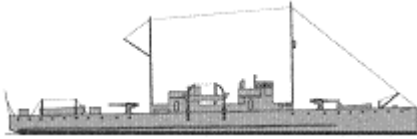
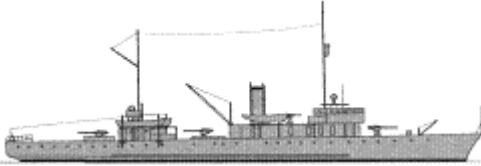
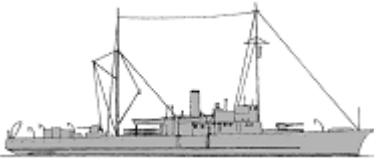
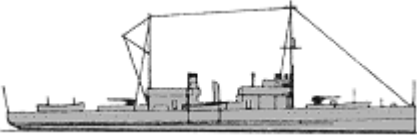
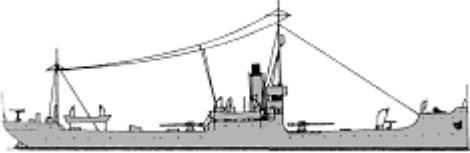
Diane	9	79	Diane	1932		651/807t, 64.4x6.2x4.3m, 2d/em, 1400/1000hp, 14/9kts, 41p, 80m; 1x1-75/35, (4+1x2)-550TT, 1x2-400TT
		80	Méduse	1932		
		81	Antiope	1932		
		82	Amphitrite	1933		
		83	Amazone	1933		
		84	Orphée	1933		
		85	Oréade	1933		
		86	La Psyché	1933		
		87	La Sybille	1934		
Orion	2	88	Orion	1932		656/822t, 66.8x6.2x4.4m, 2d/em, 1400/1000hp, 14/9kts, 41p, 80m; 1x1-75/35, (4+1x2)-550TT, 1x2-400TT
		89	Ondine	1932		
Surcouf	1	90	Surcouf	1934		3250/4304t, 110.0x9.0x7.3m, 2d/em, 7600/3400hp, 18.5/10kts, 118p, 80m; 1x2-203/50, 2x1-37/50, 2x2-13.2, (4+1x4)-550TT, 1x4-400TT, 1seaplane (MB.411)

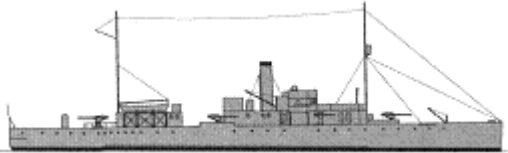
ESCORTS

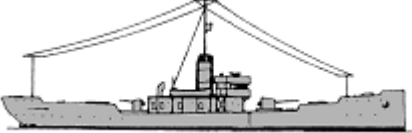

Aldébaran	4	1	Algol	1916		1470t, 81.5x10.5x4.2m, 2b,1vte, 2800hp, 17.5kts, 103p; 2x1-139/45, 2x1-75/35, 2DCT, 1DCR	
		2	Altair	1916			
		3	Antarès	1916			
		4	Régulus	1917			
SL	Andromédé	1	5	Ville d'Ys	1917		1250t, 83.5x12.0x5.0m, 2b,1vte, 2675hp, 17kts, 103p; 1x1-100/45, 3x1-75/35, 2x1-47/40
Bougainville	6	6	Dumont d'Urville	1932		2600t, 103.7x12.7x4.5m, 2d, 3200hp, 15.5kts, 183p; 3x1-139/40, 4x1-37/50, 50m, 1seaplane (GL.832)	
		7	Bougainville	1932			
		8	Savorgnan de Brazza	1932			
		9	D'Entrecasteaux	1933			
		10	Rigault de Genouilly	1933			
		11	Amiral Charner	1933			
Ardent	11	1	Alerte	1916		400(2,5,9)-410(1,3,4,6-8,10,11)t, 60.2x7.2x2.9m, 2b,1vte(2,5,9)-2vte(1,3,4,6-8,10,11), 1200-2200hp, 14-17kts, 55-60p; 2x1-145/45(2,5,9), 2x1-100/45(1,3,4,6-8,10,11), 2DCT, MS	
		2	Ardent	1916			
		3	Gracieuse	1916			
		4	Malicieuse	1916			
		5	Sans Souci	1916			
		6	Audacieuse	1917			
		7	Batailleuse	1917			

FS		8	Dédaigneuse	1917			
		9	Étourdi	1917			
		10	Impétueuse	1917			
		11	Tapageuse	1917			
	Friponne	3	12	Diligente	1918		315t, 66.4x7.0x2.8m, 2d, 900hp, 14.5kts, 54p; 2x1-100/45, 2DCT
			13	Engageante	1918		
			14	Surveillante	1918		
	Marne	6	15	Marne	1917		601(18)-566(19-23)t, 78.0x8.9x3.4m, 2b,2gt, 5000(18)-4000(19-23)hp, 21(18)-20(19-23)kts, 113p; 4x1-100/45, 1x1-75/35(20), 2x1-65/50(18,19,21-23), 1DCR
			16	Oise	1917		
			17	Somme	1917		
			18	Yser	1917		
			19	Aisne	1918		
			20	Meuse	1918		
	Luronne	1	21	Luronne	1917		400t, 60.2x7.2x2.9m, 2d, 630hp, 13.7kts, 54p; 2x1-100/45, 2DCT
	Conquérante	1	22	Conquérante	1917		457t, 66.4x7.9x2.8m, 2d, 1800hp, 17kts, 54p; 2x1-100/45, 2DCT
	Amiens	21	23	Arras	1918		850t, 74.9x8.7x3.2m, 2b,2gt, 5000hp, 20kts, 103p; 2x1-139/55, 1x1-75/35, 2DCT, 1seaplane (GL.832(27))
			24	Reims	1918		
			25	Amiens	1920		
			26	Bapaume	1920		
			27	Belfort	1920		
28			Calais	1920			
29			Coucy	1920			
30			Épinal	1920			
31			Lassigny	1920			
32			Nancy	1920			
33			Tahure	1920			
34			Toul	1920			
35			Laffaux	1920			
36			Vimy	1920			
37	Craonne	1921					
38	Liévin	1921					
39	Lunéville	1921					
40	Péronne	1921					
41	Révigny	1921					

		42	Vitry-le-François	1921		
		43	Montdement	1922		
	Ailette	1	44 Ailette	1918		492t, 70.0x8.3x3.1m, 2b,2gt, 4000hp, 20kts, 107p; 4x1-100/45, 1x1-75/35
	Scarpe	3	45 Ancre	1918		604t, 76.2x8.7x3.3m, 2b,2gt, 5000hp, 20kts, 107p; 4x1-100/45, 1x1-75/35, 2DCT
46 Scarpe			1918			
47 Suippe			1918			
	Flamant	1	48 Quentin Roosevelt	1918		585t, 50.0x8.4x5.8m, 2b,1vte, 1200hp, 14.5kts, 53p; 1x1-75/35, 1x1-47/50
	Dubordieu	3	49 Du Chaffault	1918		453t, 64.9x8.2x3.1m, 2b,2gt, 2000hp, 16.5kts, 74p; 1x1-139/45, 1x1-100/45, 2DCT
50 Dubordieu			1918			
51 Du Couëdic			1920			
	C1	12	1 - C25, 26, 31, 51, 56, 58, 74, 81, 91, 92, 95, 98	1917 - 1918		85t, 33.5x4.7x2.3m, 3pe, 660hp, 16.5kts, 27p; 1x1-75/35, 1DCT
	C101	14	13 Ch102	1919		150t, 43.4x5.2x2.4m, 2b,2vte, 1300hp, 16.5kts, 31p; 1x1-75/35, 1DCT
			14 Ch103	1919		
			15 Ch104	1919		
			16 Ch105	1919		
			17 Ch106	1919		
			18 Ch107	1919		
			19 Ch108	1919		
			20 Ch109	1919		
			21 Ch110	1919		
			22 Ch113	1920		
			23 Ch114	1920		
			24 Ch115	1920		
			25 Ch116	1920		
			26 Ch117	1920		
	Ch1	4	27 Ch1	1934		180t, 48.1x5.5x1.9m, 2d, 2400hp, 20kts, 41p; 1x1-75/35, 1DCR, MS
			28 Ch2	1934		
			29 Ch3	1934		
			30 Ch4	1934		
	Loup	3	1 Loup	1917	No picture	285t, 1b,1vte, 600hp, 10kts; 1x1-75/35
			2 Marcassin	1917		
			3 Sanglier	1917		
			4 Mammouth	1917		

PC	Hippopotame	4	5	Hippopotame	1918	No picture	970t, 2b,1vte, 1800hp, 12kts; 2x1-75/35	
			6	Rhinocéros	1918			
			7	Mastodonte	1919			
	Aurochs	4	8	Zébu	1917	No picture	290t, 1b,1vte, 650hp, 10kts; 1x1-90/24, 1x1-47/40	
			9	Aurochs	1918			
			10	Renne	1918			
			11	Élan	1919			
	Clameur	4	12	Fracas	1917	No picture	370t, 2b,1vte, 720hp, 12kts; 1x1-90/24	
			13	Clameur	1918			
			14	Tumulte	1918			
			15	Vacarme	1918			
	Athlete	2	16	Athlete	1917	No picture	585t, 1b,2vte, 500hp, 12kts; 2x1-120/40	
			17	Lutteur	1919			
	Navarin	2	18	Lutzen	1918	No picture	640t, 1vte, 500hp, 11kts, 31p; 1x1-100/45	
			19	Malakoff	1918			
		Mauviette	1	20	Passereau II	1918		460t, 43.5x7.3x4.2m, 1b,1vte, 10kts; 1x1-90/24, 1x1-47/40, MS
	Pluvier	9	21	Faisan	1918	No picture	(680-780)t, 1vte, 750hp, 11kts	
			22	Gelinotte	1918			
			23	Heron II	1918			
			24	Paon	1918			
			25	Pigeon	1918			
			26	Pingouin II	1918			
			27	Pintade	1918			
			28	Ramier	1918			
			29	Tourterelle	1918			
	Crabe	11	30	Cèdre	1918	No picture	(360-370)t, 1b,1vte, 400hp, (9-10)kts; 1x1-90/24	
			31	Chêne	1918			
			32	Crabe	1918			
			33	Erable	1918			
			34	Orme	1918			
			35	Tourteau	1918			
			36	Frêne	1919			
			37	Hêtre	1919			
			38	Peuplier	1919			
			39	Calmar	1920			
			40	Homard	1920			

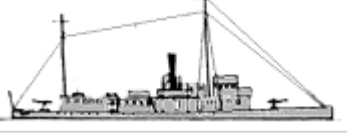
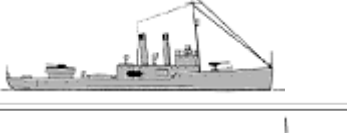
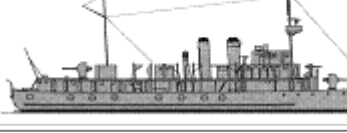

OTHER FIGHTING SHIPS



PR	Doudart de la Grée	1	1	Doudart de la Grée	1909		183t, 54.4x6.7x1.0m, 2b,2vte, 900hp, 14kts, 66p; 1x1-75/35, 2x1-37/23
	Balny	1	2	Balny	1920		226t, 54.4x6.7x1.0m, 2b,2vte, 900hp, 14kts, 59p; 2x1-75/35, 2x1-37/23
	Vigilante	2	3	Vigilante	1923		218t, 51.8x7.7x1.2m, 2b,2vte, 600hp, 12kts, 42p; 2x1-75/35, 2x1-37/23
			4	Argus	1923		
	Ch101	2	5	Commandant Bourdais	1920		150t, 43.4x5.2x2.4m, 2b,2vte, 1300hp, 16.5kts, 31p; 1x1-75/35
			6	Avalanche	1920		
Francis Garnier	1	7	Francis Garnier	1931		639t, 62.5x10.3x2.2m, 2b,2vte, 3200hp, 15kts, 103p; 2x1-100/45, 1x1-75/50, 2x1-37/50	
Mytho	1	8	Mytho	1933	No picture	95t, 35.0x5.4x0.9m, 2d, 250hp, 10kts; 1x1-75/35, 1x1-47/40, 1x1-81/8mortar	

COASTAL FORCES

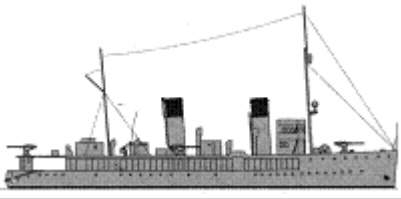
PT	VTB1	7	1 - 7	VTB1 - 7	1928 - 1929		11t, 18.3x3.4x0.9m, 2pe, 900hp, 40kts, 5p; 2-400TT
----	------	---	-------	----------	-------------	--	--

MINE WARFARE SHIPS

AML -	2	1	Castor	1916		4576t, 75.2x17.3x6.4m, 6b,3vte, 6400hp, 14kts; 4x1-100/45, 2x1-37/50, 268m
		2	Pollux	1917		2463t, 64.2x15.5x6.0m, 6b,3vte, 4000hp, 14kts; 4x1-100/45, 2x1-37/50, 236m
MS	1	1	No321	1907		101t, 38.0x4.4x1.9m, 2b,1vte, 2000hp, 26kts, 23p; 2x5-37/20, 1-450TT, MS
		3	2	Aventurier		1914
	3		Téméraire	1914		
	4		Intrépide	1914		
	2	5	Granit	1918	360t, 57.6x7.9x2.3m, 1b,1vte, 600hp, 12.5kts, 63p; 2x1-65/50, MS	
6		Mica	1918			

					
Albâtre	2	7 Meulière	1919		380t, 57.6x7.9x2.3m, 1b,1vte, 500hp, 10.5kts, 63p; 1x1-65/50, MS
		8 Quartz	1919		

NAVAL AVIATION *(approximately, maximal number of delivered planes signed)*

Deck planes	F: 18 Wib.74; FR: 18 Wib.75; TB: 50 PL.7; R: 30 PL.10, 30 PL.101
Seaplanes	TB: 16 PL.15; B: 33 F.B.A.17 HMB.2; R: 141 F.B.A.17 HE.2, 10 F.B.A.17 HL.2, 15 CAMS.37A <i>(delivery till 1935)</i> , 24 GL.810Hy, 20 GL.811Hy, 29 GL.812Hy, 13 GL.813Hy, 22 GL.832Hy

© Ivan Gogin, 2011-14

[home](#)

[World navies yesterday](#)

[1935](#)

Germany 01 January 1935

IN SERVICE: 4 battleships-predreadnoughts, 1 seaplane tender, 2 heavy cruisers, 1 protected cruiser, 5 light cruisers, 25 torpedo boats, 2 fishery protection vessels, 2 dispatch vessels, 1 gunnery training ship, 1 gunboat, 7 motor torpedo boats, 2 motor anti-submarine boats, 2 minelayers, 3 mine transports, 28 minesweepers, 16 minesweeping boats

CAPITAL SHIPS

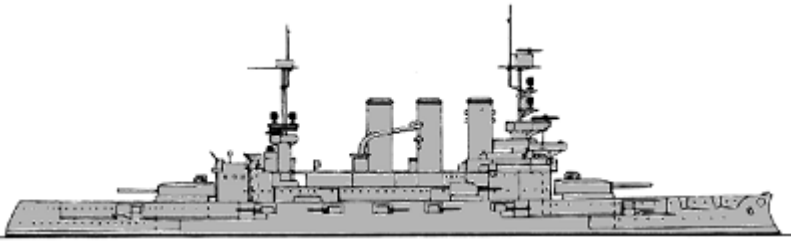
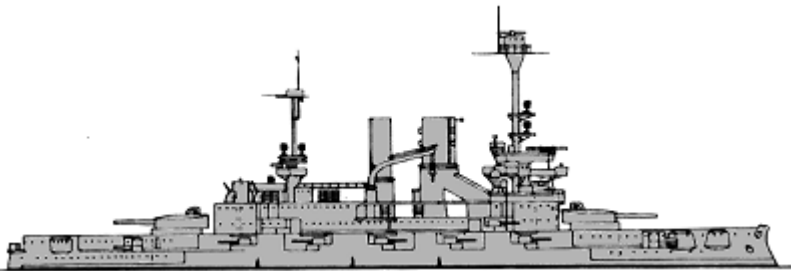
BB	Braunschweig	1	1	Hessen	1905		14394t, 127.7x25.6x8.1m, 10b,3vte, 16500hp, 18.2kts, 743p; 225belt, 40deck, 250turrets, 300CT; 2x2-283/40, 12x1-173/40, 4x1-88/45, 4x1-500TT
	Deutschland	3	2	Hannover	1907		13994t, 127.6x22.2x8.3m, 12b,3vte, 20540hp, 18.6kts, 743p; 240belt, 40deck, 280turrets, 300CT; 2x2-283/40, 14x1-173/40(2), 14x1-149/45(3,4), 4x1-88/45(4), 2x1-88/45(3), 4x1-500TT
3			Schlesien	1908			
4			Schleswig-Holstein				

AIRCRAFT CARRYING SHIPS

AV	Krischan I	1	1	Krischan I	1934		250t, 38.2x6.7x2.5m, 2d, 750hp, 15kts, 19p; 1seaplane (He60)
----	------------	---	---	------------	------	--	--



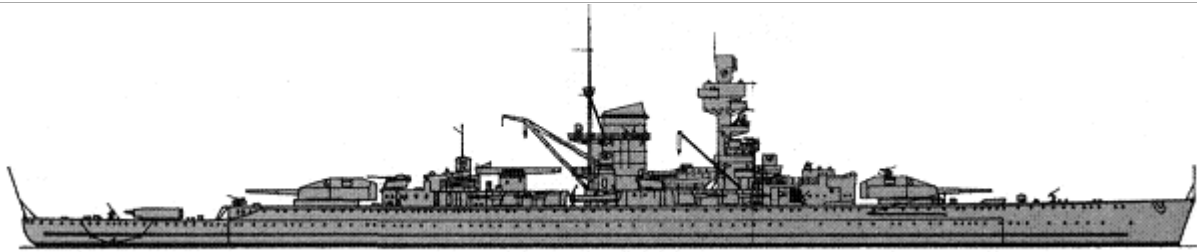
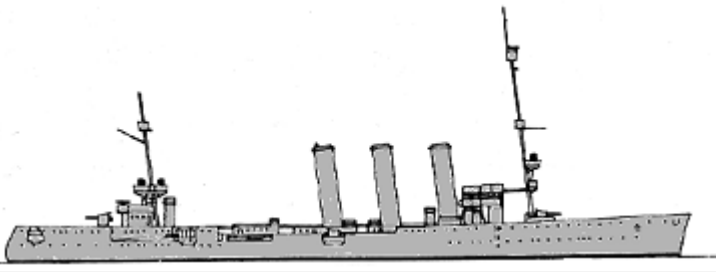
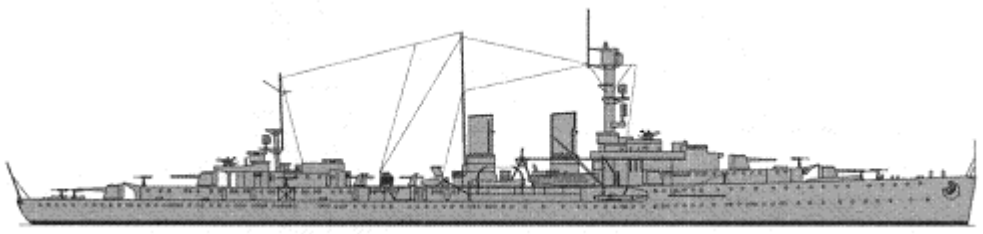
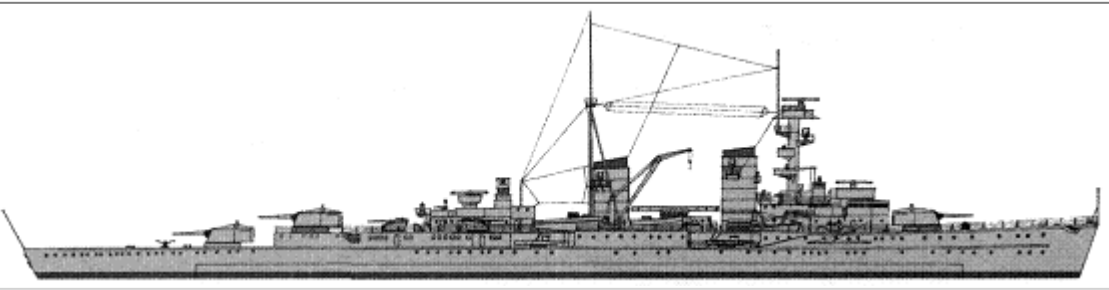
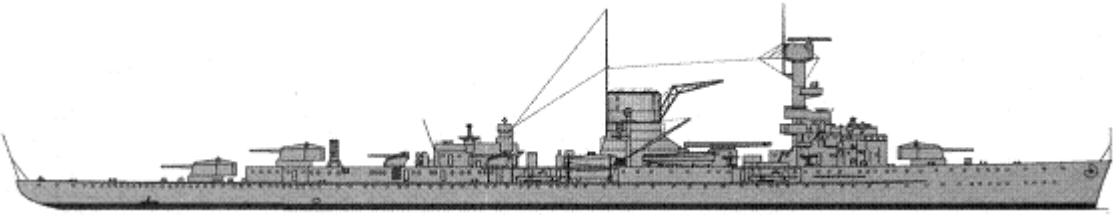

CRUISERS

		1	Deutschland	1933			14290(1)-15180(2)t, 186.0x20.7(1)-21.3(2)x5.8m, 8d(2),
--	--	---	-------------	------	--	--	--

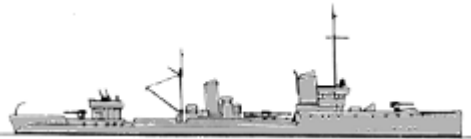
CA	Deutschland	2	2	Admiral Scheer	1934		56800hp, 28kts, 1150p; 80belt, 63(1)-58(2)deck, 150turrets, 150CT; 2x3-283/52, 8x1-149/55, 3x2-88/78, 4x2-37/83, 8x1-20/65, 2x4-533TT		
CL	Bremen	1	1	Berlin	1905		3816t, 113.8x13.3x5.6m, 10b,2vte, 11750hp, 23kts, 288p; 80slopes, 35deck, 50shields, 100CT; 8x1-105/45, 2x1-500TT		
	Emden	1	2	Emden	1925		6990t, 155.1x14.3x6.6m, 10b,2gt, 45900hp, 29kts, 650p; 50belt, 40deck, 20shields, 100CT; 8x1-149/45, 3x1-88/45, 2x2-533TT, 120m		
	Königsberg	3	Königsberg	1929		1930	7700t, 174.0x15.2x5.6m, 6b,2gt/2d(2), 65000/1800hp, 32kts, 850p; 65belt, 40deck, 30turrets, 100CT; 3x3-149/60, 3x1-88/45, 4x2-37/83, 4x1-20/65, 4x3-533TT, 120m		
		4	Karlsruhe	1929					
		5	Köln	1930					
Leipzig	1	6	Leipzig	1931					8100t, 177.1x16.3x4.9m, 8b,2gt+4d(3), 72400hp, 32kts, 850p; 50belt, 25deck, 30turrets, 100CT; 3x3-149/60, 4x1-88/45, 4x2-37/83, 4x1-20/65, 4x3-533TT, 120m

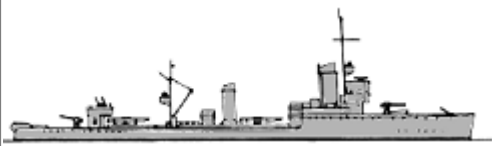
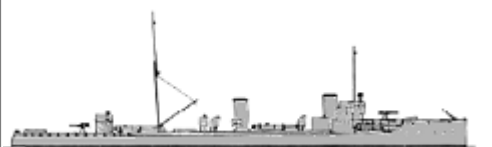
TORPEDO SHIPS

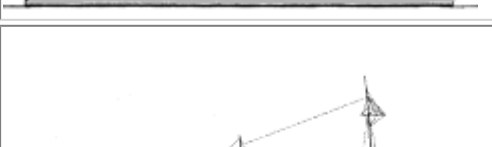
V150	6	1	T151	1908		691t, 72.5x7.8x3.0m, 4b,2vte, 10900hp, 30kts, 84p; 2x1-88/45, 1x2-500TT(1-3), 3x1-450TT(4-6)
		2	T153	1908		
		3	T155	1908		
		4	T156	1908		
		5	T157	1908		
		6	T158	1908		
		V180	1	7		

TB							
	G192	1	8	T196	1911		810t, 74.0x7.9x3.0m, 4b,2t, 18200hp, 32kts, 76p; 2x1-105/45, 2x1-20/65, 2x2-500TT
	G7	4	9	G7	1912		884t, 76.1x7.6x3.1m, 3b,2t, 16000hp, 30kts, 74p; 2x1-105/45, 2x1-500TT, 18m
			10	G8	1912		
			11	G10	1912		
			12	G11	1912		
	S13	1	13	S23	1913		749t, 71.5x7.4x2.8m, 3b,2t, 15700hp, 32.5kts, 74p; 2x1-105/45, 2x1-500TT, 18m
	Möwe	6	14	Möwe	1926		1213(14)-1290(15-19)t, 88.8(14)-88.5(15-19)x8.3x2.8m, 3b,2gt, 22100(14)-23000(15-19)hp, 32(14)-33(15-19)kts, 120p; 3x1-105/45, 2x3-533TT, 30m
			15	Greif	1927		
			16	Seeadler	1927		
			17	Albatros	1927		
			18	Kondor	1928		
19			Falke	1927			
Wolf	6	20	Wolf	1928		1320t, 92.6x8.6x2.8m, 3b,2gt, 23000hp, 34kts, 120p; 3x1-105/55, 2x3-533TT, 30m	
		21	Iltis	1928			
		22	Jaguar	1929			
		23	Leopard	1929			
		24	Luchs	1929			
		25	Tiger	1929			

ESCORTS

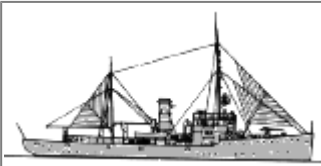

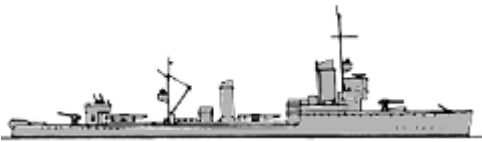
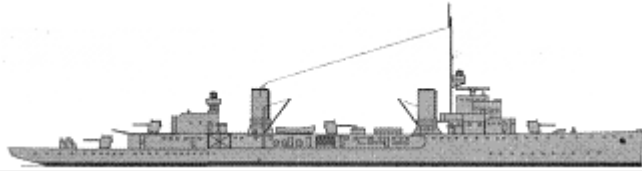
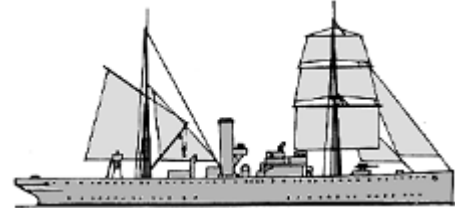

FPV	Elbe	2	1	Elbe	1931		870t, 58.0x8.5x3.7m, 2d, 1600hp, 14kts, 65p; 1x1-88/45, 1x1-37/83
			2	Weser	1931		

OTHER FIGHTING SHIPS

S138	1	1	Pfeil	1907		684t, 70.7x7.8x2.8m, 4b,2vte, 11000hp, 30.3kts, 80p; 2x1-20/65
------	---	---	-------	------	--	--

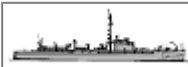



DV	V180	1	2	Blitz	1910		775t, 73.9x7.9x3.1m, 4b,2t, 18000hp, 32kts, 84p; 2x1-20/65
AGML	Bremse	1	1	Bremse (TS)	1932		2054t, 103.6x10.2x2.8m, 8d(2), 26000hp, 27kts, 192p+90; 4x1-128/45, 2x1-20/65, 350m
PG	Meteor	1	1	Meteor	1924		1504t, 71.1x10.2x3.6m, 2d, 2200hp, 14.5kts, 124p; 1x1-88/45

COASTAL FORCES

PT	S1	1	1	S1	1930		52t, 26.9x4.4x1.4m, 3pe/1pe(3), 2700/100hp, 34.2kts, 12p; 1x1-13.2, 2-533TT
	S2	4	2 - 4	S2 - 5	1932		58t, 27.9x4.5x1.5m, 3pe/1pe(3), 3000/100hp, 33.8kts, 13p; 1x1-20/65, 2-533TT
	S6	1	5	S6	1933		68t, 32.4x5.1x1.4m, 3d, 3960hp, 32kts, 12p; 1x1-20/65, 2-533TT
	S7	2	6, 7	S7, 8	1934		86t, 32.4x5.1x1.4m, 3d, 3960hp, 36.5kts, 18p; 1x1-20/65, 2-533TT
PS	UZ23	2	1, 2	UZ27, 29	1918		60t, 31.0x4.4x1.3m, 2pe, 570hp, 16kts, 14p; DCR

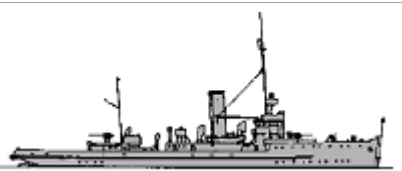
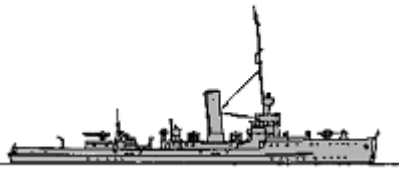
MINE WARFARE SHIPS

ML	MWI	2	1	MT1	1917		673t, 53.1x9.3x2.3m, 2b,2vte, 371hp, 9.5kts, 47p; m
			2	MT2	1917		
MT	Lauting	3	1	Lauting	1934		1253(1,2)-1220(3)t, 56.7x10.4x4.4m, 1d, 450hp, 9.5kts, 40p; 4x1-20/65, 370m
			2	Rhein	1934		
			3	Otter	1934		
	M27	1	1	M50	1916		503t, 58.2x7.3x2.3m, 2b,2vte, 1890hp, 16.5kts, 40p; 3x1-88/45, 30m, MS

							
MS	M57	27	2	M60	1918		535(2,3)-539(4)- 553(5,7,8)-548(10,13-17)- 564(11,19,20)-560(12,21,27)- 550(22,23-26,28,29)-590(18)t, 59.3(2-4,6-9,11,18-20)-58.2(5)-59.6(10,12-17,21-25,28,29)-59.5(26)x7.3(2,3,5,6,9,10,12-17,21-29)-7.4(4,7,8,11,18-20)x2.3m, 2b,2vte, 1750(2,3)-1850(4,5,7,8,12,18,21-25,27-29)- 1790(5)-1870(6,9)- 1840(10,13-17)-1600(26)hp, 16(2-5,7,8,10,12-18,21-25,27-29)-16.5(6,9)-15(26)kts, 40p; 2x1-105/45(2-4,10-29), 2x1-88/45(5,8,9), 3x1-88/45(6,7), 30m, MS
			3	M61	1918		
			4	M66	1917		
			5	M72	1918		
			6	M75	1917		
			7	M84	1917		
			8	M85	1918		
			9	M89	1918		
			10	M98	1918		
			11	M102	1918		
			12	M104	1918		
			13	M107	1918		
			14	M108	1918		
			15	M109	1918		
			16	M110	1918		
			17	M111	1918		
			18	M113	1920		
			19	M115	1918		
			20	M117	1919		
			21	M122	1919		
			22	M126	1919		
			23	M129	1919		
			24	Fuchs (TS)	1919		
			24	M132	1919		
			25	M136	1919		
			26	M145	1919		
			27	Taku	1919		
			28	M157	1919		
MSB	R1	1	1	R1	1931		43t, 24.5x4.4x1.2m, 2d, 700hp, 17kts, 15p; 1x1-20/65, MS
	R2	14	- 15	R2 - 7, 9 - 16	1932 - 1934		44(2)-46(3-5)-48(6,7)-53(8-15)t, 24.5(2)-26.5(3-7)-27.8(8-15)x4.4x1.5(2)-1.6(3-7)-1.3(8-15)m, 2d, 750(2,6,7-13)-700(3-5)-770(14,15)hp, 20(2)-19.5(3-7)-16.5(8-13)-19.8(14,15)kts, 15p; 1x1-20/65, MS
	R8	1	16	R8	1934		63t, 27.8x4.5x1.1m, 2d, 750hp, 16.5kts, 15p; 1x1-20/65, MS

© Ivan Gogin, 2011-14

[home](#)

[World navies yesterday](#)

[1935](#)

Greece 01 January 1935

CAPITAL SHIPS

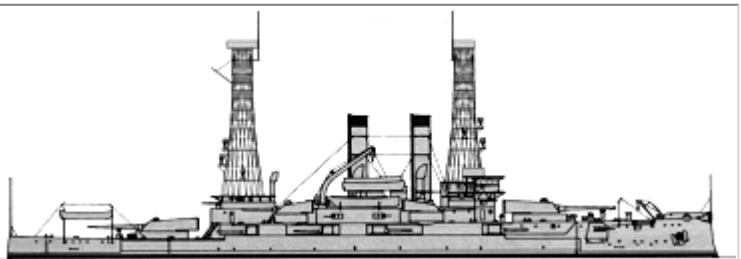

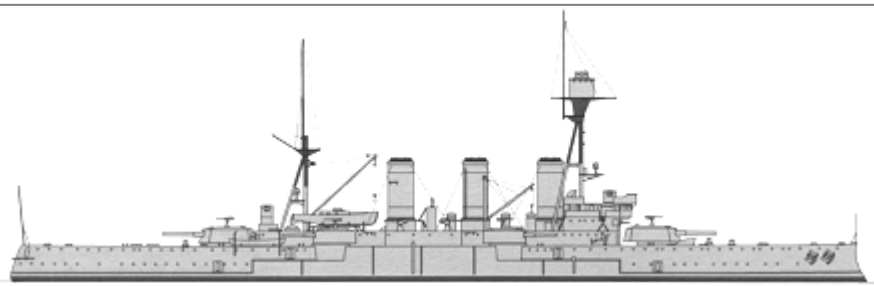
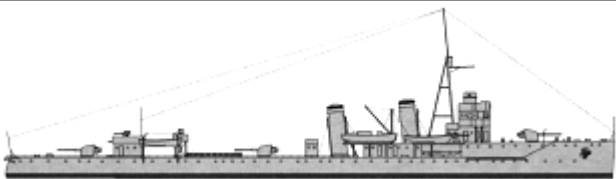

BB	Kilkis	1	1	Kilkis	1908		<p>14465t, 116.4x23.5x7.5m, 8b,2vte, 10000hp, 17kts, 744p; 229belt, 37deck, 305turrets, 229CT; 2x2-305/45, 4x2-203/45, 8x1-178/45, 13x1-76/50, 4x1-57/40, 2-533TT</p>
----	--------	---	---	--------	------	--	---

CRUISERS

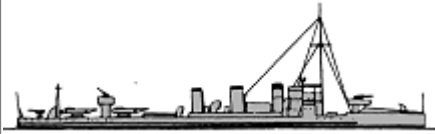

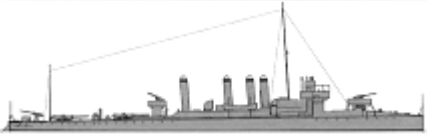
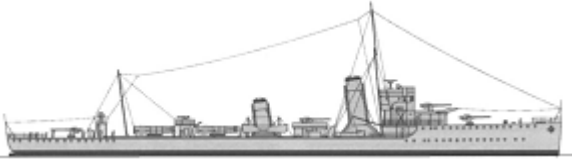
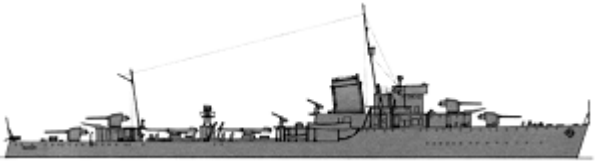
CA	Averof	1	1	Averof	1911		<p>10200t, 140.8x21.0x7.5m, 22b,2vte, 19000hp, 22.5kts, 670p; 200belt, 50deck, 140turrets, 180CT; 2x2-234/45, 4x2-190/45, 12x1-76/40, 4x1-40/39</p>
CL	Elli	1	1	Elli	1913		<p>2750t, 98.1x11.9x4.3m, 3b,3t, 7500hp, 20.5kts, 232p; 51slopes, 51deck, 50CT; 3x1-152/50, 2x1-76/40, 2x1-57/40, 2x1-450TT, 110m</p>

TORPEDO SHIPS

Niki	1	Niki	1906		<p>350t, 67.0x6.6x2.7m, 4b,2vte, 6800hp, 30kts, 58p; 2x1-88/30, 1x1-40/39, 2x1-450TT</p>
	2	Aspis	1906		

DD	Thyella	2	3	Thyella	1907		380t, 67.1x6.2x1.8m, 4b,2vte, 6000hp, 30kts, 70p; 2x1-88/30, 1x1-40/39, 2x1-450TT	
			4	Sfendoni	1907			
	Aetos	4	5	Aetos	1912		1300t, 89.3x8.5x2.6m, 4b,2t, 19750hp, 32kts, 110p; 4x1-102/50, 2x1-40/39, 2x3-533TT	
			6	Ierax	1912			
			7	Leon	1912			
			8	Panthir	1912			
	Hydra	4	9	Kountouriotis	1932		2050t, 94.3x9.8x3.3m, 3b,2gt, 44000hp, 38kts, 156p; 4x1-120/50, 3x1-40/39, 2x3-533TT, 40m(9,10)	
			10	Hydra	1932			
			11	Psara	1933			
			12	Spetsai	1933			
	TB	Aigli	4	1	Aigli	1912		125t, 45.0x5.0x1.2m, 2b,1vte, 2400hp, 24kts, 20p; 1x1-37/83, 2x1-450TT
				2	Alkyoni	1914		
3				Arethousa	1913			
4				Doris	1913			
Panormos		2	5	Proussa	1916		330t, 58.8x5.8x1.5m, 2b,2t, 5000hp, 28kts, 38p; 1x1-66/30, 1x1-37/83, 2x1-533TT, 12m	
			6	Pergamos	1916			
Kyzikos		3	7	Kyzikos	1915		330t, 60.5x5.6x1.6m, 2b,2t, 5000hp, 28.5kts, 38p; 1x1-66/30, 1x1-37/83, 2x1-533TT, 12m	
			8	Kios	1915			
			9	Kidoniai	1916			

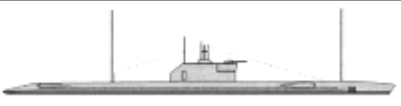
SUBMARINES

SS	Katsonis	2	1	Katsonis	1928		576/775t, 62.5x5.3x3.4m, 2d/em, 1200/1000hp, 14/9.5kts, 39p, 80m; 1x1-100/40, 6-533TT
			2	Papanikolis	1927		
	Glafkos	4	3	Protefs	1929		790/960t, 68.6ppx5.7x4.2m, 2d/em, 1420/1200hp, 14/9.5kts, 41p, 85m; 1x1-100/40, 1x1-40/39, 8-533TT
			4	Nirefs	1930		
			5	Triton	1930		
			6	Glafkos	1930		

OTHER FIGHTING SHIPS

PG	Kichli	2	2, 3	Kichli, Kissa	1884	No picture	86t, 24.2x4.9x2.1m, 1vc, 162hp, 10kts
----	--------	---	------	---------------	------	------------	---------------------------------------

COASTAL FORCES

PT	2	2	1, 2	T1, 2	1929		15t, 16.8x3.4x1.0m, 2pe, 750hp, 40.4kts, 5p; 2-450TR, 1DCR
YP	A1	6	1-6	A1-6	1926-1927	No picture	58t, 13.0xxm; 1x1-76/40, 1DCR
	A32	1	7	A32	1930	No picture	

MINE WARFARE SHIPS

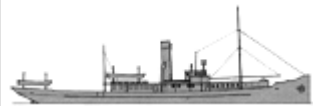



ML	Pleias	1	1	Pleias	1928		520t, 49.4x8.2x3.8m, 1vte, 1000hp, 14kts; 50m
AML	-	3	1	Korgialenios	1916		380t; 50m
			2	Tenedos	1906		450t; 40m
			3	Paralos	1925		395t; 52m

© Ivan Gogin, 2011-14



[home](#)[World navies yesterday](#)[1935](#)

Hungary 01 January 1935

RIVER BOATS

PGR	Compo	1	Szeged	1916		133t, 44.0x6.0x1.0m, 2b,2gt, 1200hp, 15kts, 40p; 8belt, 6deck, 10turrets, 10CT; 2x1-77/30(1-3), 2x1-75/60(4), 1x1-50/12(4)	
		2	Kecskemét	1916			
		3	Baja	1916			
		4	Győr	1916			
	Komarom	2	5	Debreczen	1918		160t, 45.5x6.0x1.0m, 2b,2gt(5)-2d(6), 1400(5)-1600(6)hp, 16kts, 42p; 10belt, 6deck, 22turrets, 10CT; 2x1-84/33
		6	Sopron	1918			
YPAR	Hüszar	3	1-3	Honved, Hüszar, Tüzér	1916		18(1)-15(2,3)t, 15.2(1)-16.0(2,3)x3.1(1)-2.8(2,3)x0.7(1)-0.6(2,3)m, 2pe, 140hp, 13.5kts, 9p; 7belt, 5deck, 7turret, 7CT
	Siofok	1	4	Gödöllő	1916		60t, 36.0x4.6x0.9m, 2b,2vte, 800hp, 12kts, 27p; 5belt, 4deck, 5turret, 5CT; 1x1-66/30

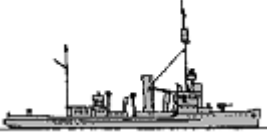
MINE WARFARE SHIPS

MLR	Körös	1	1	Körös	1918		193t, 43.0x6.0x1.4m, 1b,2vte, 600hp, 14kts, 35p; 20m
MLBR	Maros	1	1	Maros	1928		90t, 30.0x5.0x0.8m, 1d, 280hp, 11kts, 9p; 12m or MS

[home](#)

[World navies yesterday](#)

[1935](#)

Iceland 01 January 1935

ESCORTS

APC	-	3	1	Sudin	1895		811brt
			2	Thor	1922		226brt
			3	Ægir	1929		507brt

© Ivan Gogin, 2011-15

[home](#)[World navies yesterday](#)[1935](#)

INDIA 01 January 1935

ESCORTS

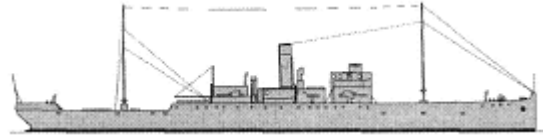
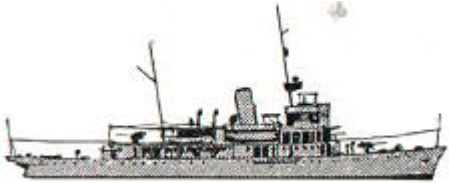
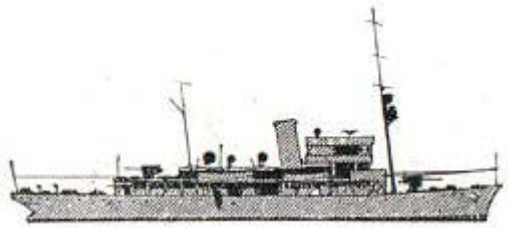
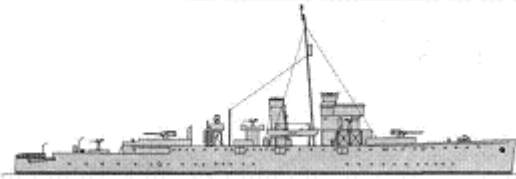
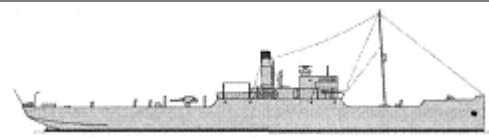
SL	Aubretia	1	1	Cornwallis	1917		1450t, 81.7x10.2x3.4m, 2b, 1vte, 2500hp, 17.5kts, 92p; 2x1-102/40, 2x1-40/39, 2DCT, 1DCR
	Lawrence	1	2	Lawrence	1919		1412t, 69.6x10.4x3.6m, 2b, 2t, 1900hp, 15kts, 119p; 2x1-102/40, 2x1-47/40, 2x-40/39
	Clive	1	3	Clive	1920		2021t, 80.0x11.7x4.3m, 2b, 2t, 2000hp, 14.5kts, 123p; 2x1-102/40, 2x1-47/40, 2x1-40/39
	Hindustan	1	4	Hindustan	1930		1400t, 90.3x10.7x3.3m, 2b,2gt, 2000hp, 16.2kts, 119p; 2x1-102/40, 4x1-47/40, 1x4-12.7, 1DCR, MS
FS	PC-boat	2	1 2	Baluchi Pathan	1917 1918		780t, 75.3x7.8(1)-8.2(2)x2.4m, 2b, 2t, 3500hp, 20kts, 55p; 1x1-102/40, 2x1-76/40, 2x1-356TT, 2DCR

© Ivan Gogin, 2010-15

[home](#)

[World navies yesterday](#)

[1935](#)

Ireland 01 January 1935

ESCORTS

APC	-	1	1	Muirchú	1908		323brt; 1x1-76/40
-----	---	---	---	---------	------	--	-------------------

© Ivan Gogin, 2011-15

[home](#)[World navies yesterday](#)[1935](#)

ITALY 01 January 1935

CAPITAL SHIPS

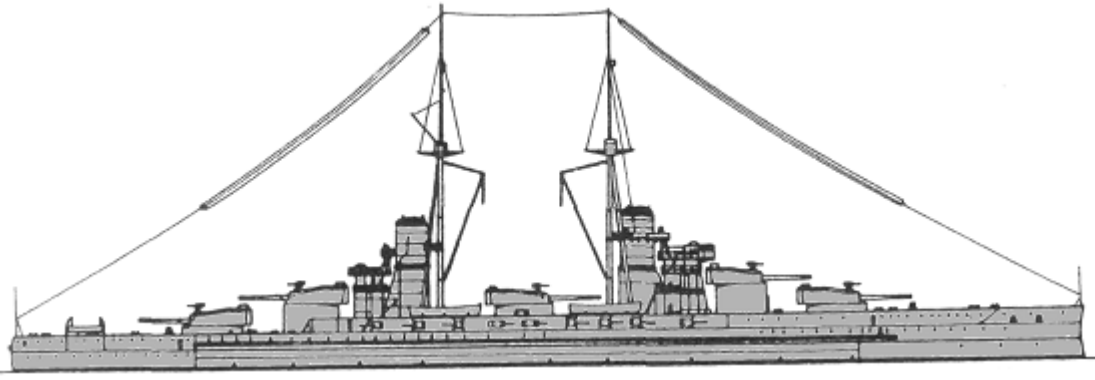
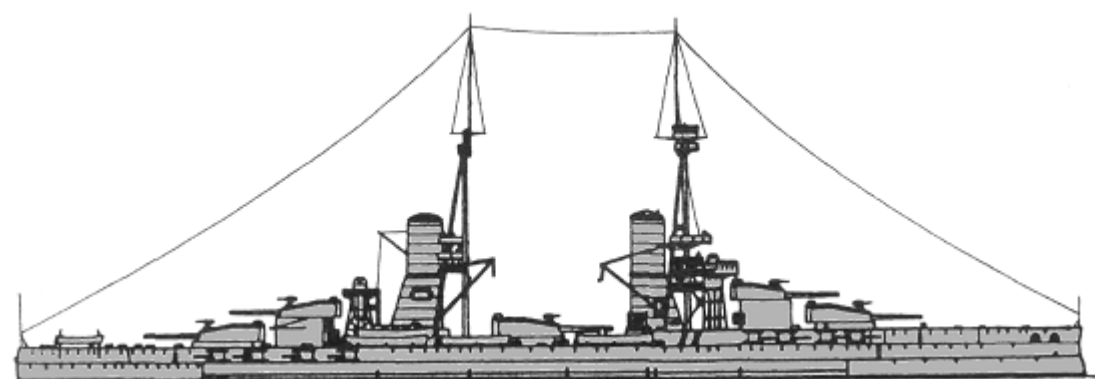
BB	Giulio Cesare	1	Giulio Cesare	1914		<p>24801(1)-24250(2)t, 176.1x28.0x8.7m, 24b(1)-20b(2),4gt, 30700(1)-31278(2)hp, 21.6(1)-22.2(2)kts, 1235p; 250belt, 30+30+24/40deck, 280turrets, 280CT; (3x3+2x2)-305/46, 18x1-120/50, 19x1-76/50(1), 20x1-76/50(2), 2x1-40/39, 1seaplane (M.41), 3-450TT</p>
		2	Conte di Cavour	1915		
	Duilio	3	Caio Duilio	1915		
		4	Andrea Doria	1916		
						
<p>24715(3)-24279(4)t, 176.1x28.0x8.9m, 20b,4gt, 30000hp, 21kts, 1232p; 250belt, 44+30+24/40deck, 280turrets, 280CT; (3x3+2x2)-305/46, 16x1-152/45, 25x1-76/50, 2x1-40/39, 1seaplane (M.41), 3-450TT</p>						

AIRCRAFT CARRYING SHIPS

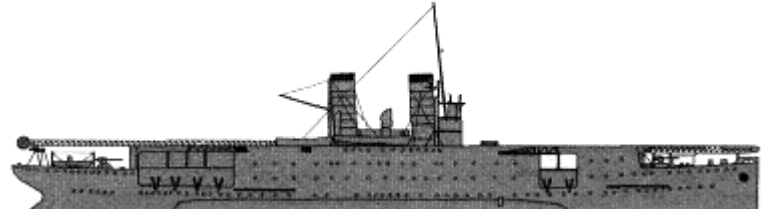
AV	Giuseppe Miraglia	1	Giuseppe Miraglia	1927		<p>5913t, 121.2x15.0x5.2m, 8b,2gt, 12000hp, 21kts, 196p; 4x1-102/35, 20seaplanes (M.18, CR.20)</p>
----	-------------------	---	-------------------	------	--	--

CRUISERS

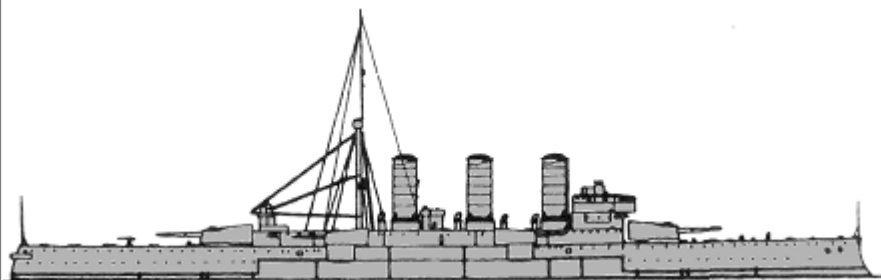
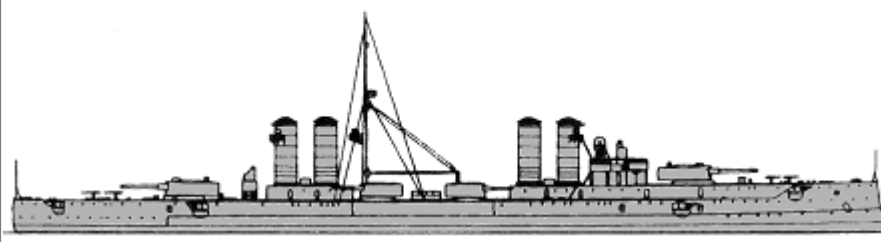
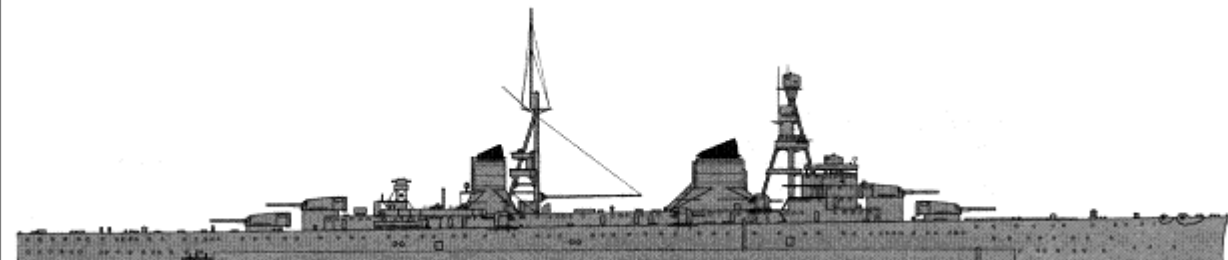
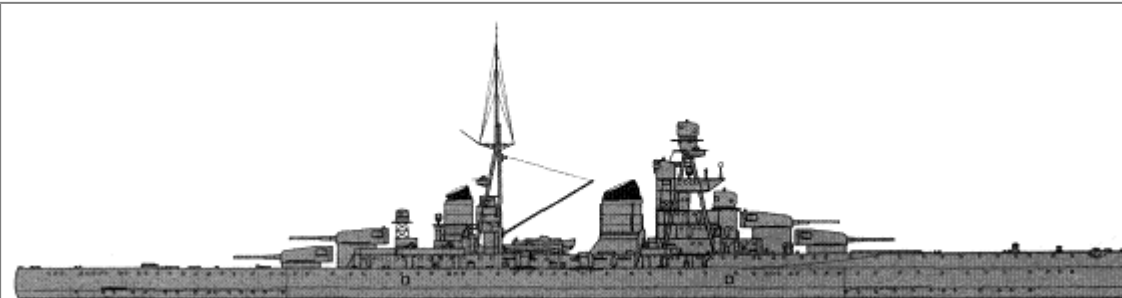
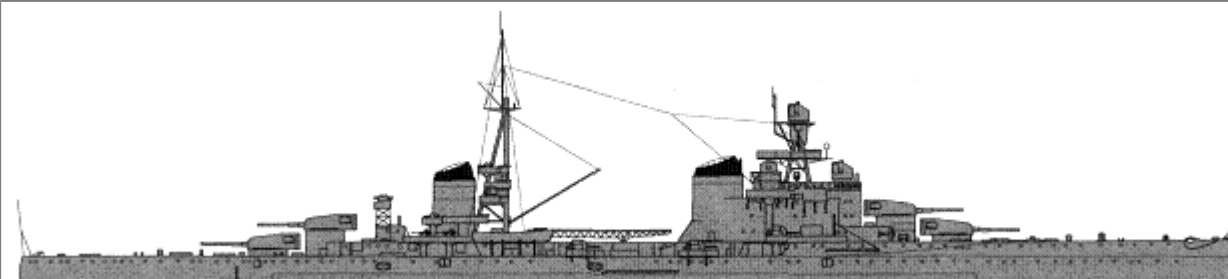

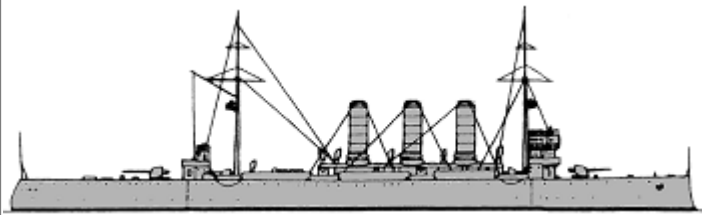
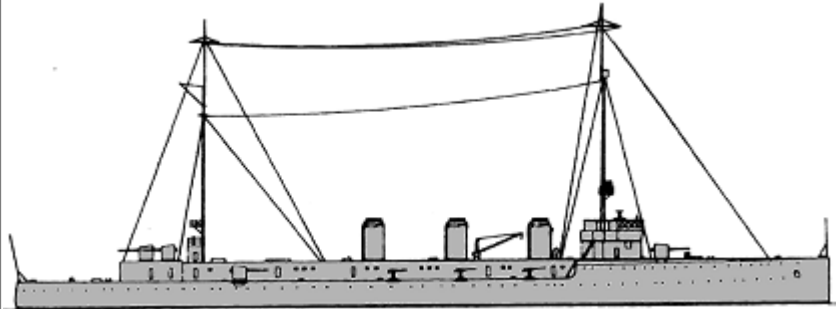
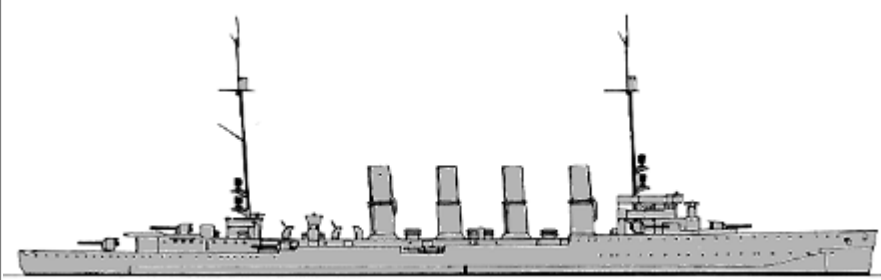
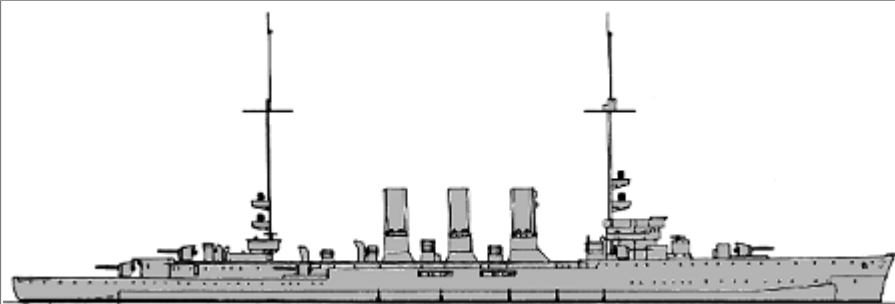
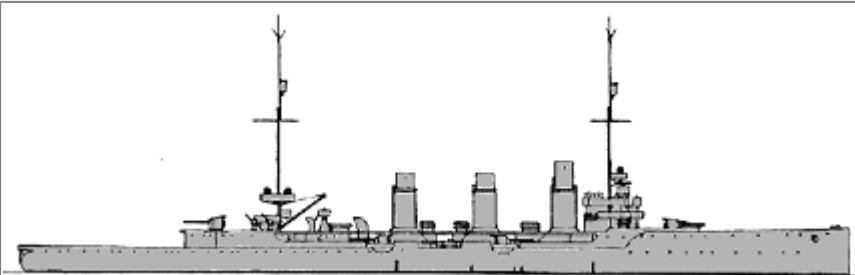
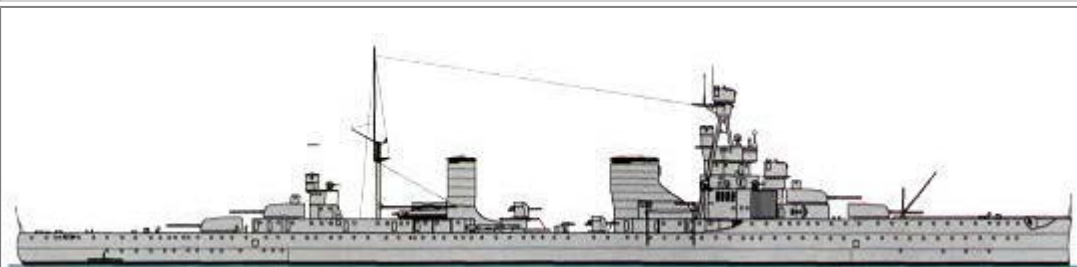

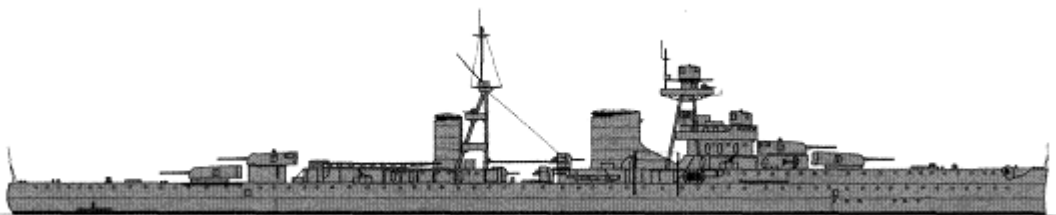
	Pisa	1	1	Pisa	1909		10600t, 140.5x21.0x7.1m, 22b,2vte, 20000hp, 23kts, 687p; 200belt, 50/130deck, 160turrets, 180CT; 2x2-254/45, 4x2-190/45, 20x1-76/40, 3-450TT, 1seaplane (P.6)
	San Giorgio	1	2	San Giorgio	1910		11300t, 140.8x21.0x7.3m, 14b, 2vte, 19500hp, 23.2kts, 705p; 200belt, 50deck, 200turrets, 250CT; 2x2-254/45, 4x2-190/45, 16x1-76/40, 3-450TT
CA	Trento	2	3	Trento	1929		13334(3)-13326(4)t, 197.0x20.6x6.8m, 12b,4gt, 150000hp, 36kts, 781p; 70belt, 50deck, 80turrets, 100CT; 4x2-203/50, 8x2-100/47, 4x1-40/39, 4x1-12.7, 8-533TT, 3seaplanes (P.6)
			4	Trieste	1928		
	Zara	4	5	Zara	1931		14300(5)-13944(6)-14330(7)-14133(8)t, 182.8x20.6x7.2m, 8b,2gt, 95000hp, 32kts, 841p; 150belt, 70deck, 150turrets, 150CT; 4x2-203/53, 8x2-100/47, 4x1-40/39, 4x1-12.7, 3seaplanes (M.41)
			6	Fiume	1931		
7			Gorizia	1932			
8			Pola	1932			
	Bolzano	1	9	Bolzano	1933		13665t, 196.9x20.6x6.8m, 10b,4gt, 150000hp, 36kts, 725p; 70belt, 50deck, 80turrets, 100CT; 4x2-203/53, 8x2-100/47, 2x1-40/39, 4x2-13.2, 8-533TT, 3seaplanes (M.41)
	Libia	1	1	Libia	1913		4466t, 111.8x14.5x5.5m, 16b,2vte, 11530hp, 22.9kts, 314p; 100deck, 76shields, 100CT; 8x1-120/45, 3x1-76/40, 2-450TT



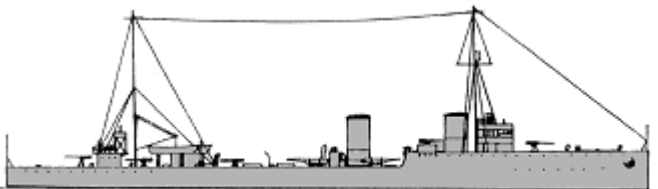
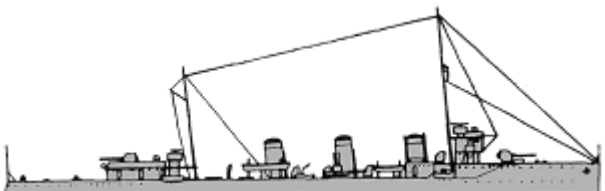
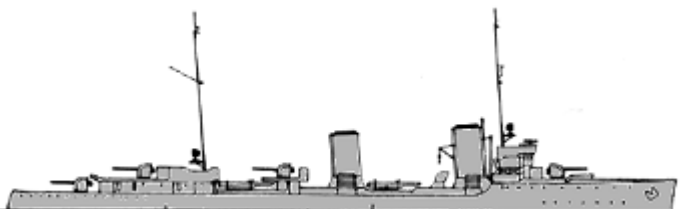
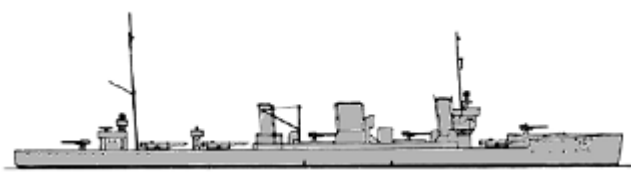
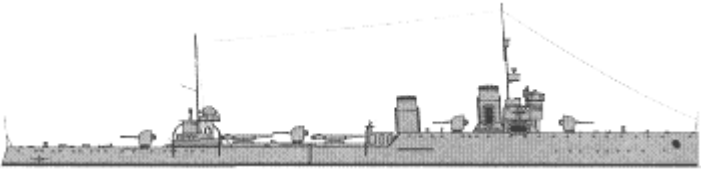
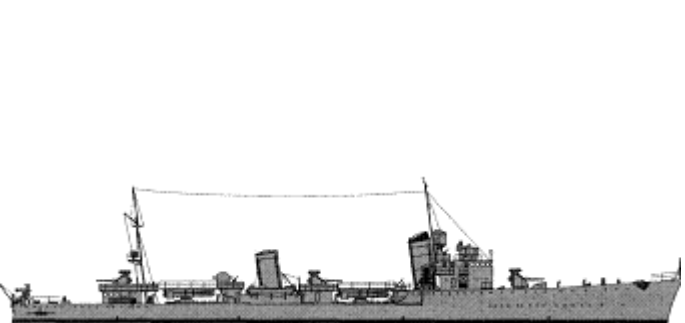

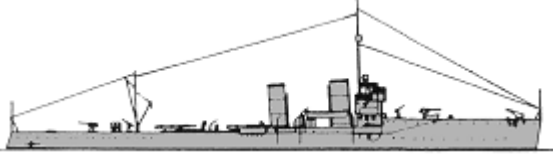
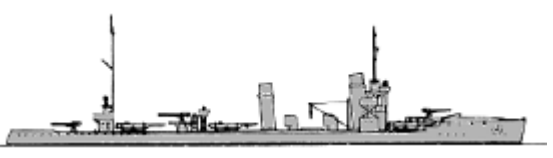
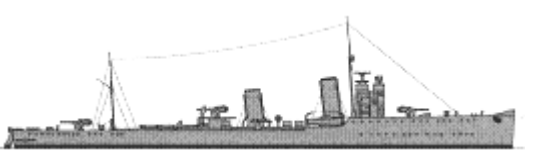

						
	Quarto	1 2	Quarto	1913		3442t, 131.6x12.8x4.1m, 10b,4t, 25000hp, 28kts, 247p; 40deck, 100CT; 6x1-120/50, 6x1-76/50, 2-450TT, 200m, 1seaplane (M.18)
	Taranto	1 3	Taranto	1912		5281t, 138.7x13.5x5.1m, 16b,2t, 27000hp, 27.5kts, 486p; 60belt, 40/60deck, 50shields, 100CT; 7x1-150/43, 2x1-76/40, (2+2x1)-500TT, 120m, 1seaplane (M.7)
CL	Ancona	1 5	Ancona	1914		6382t, 142.7x13.8x6.1m, 12b,2t, 26000hp, 27kts, 385p; 60belt, 40/60deck, 50shields, 100CT; 7x1-150/43, 3x1-76/40, 4x1-500TT, 120m, 1seaplane (M.7)
	Bari	1 6	Bari	1914		5305t, 135.3x13.6x6.0m, 10b,2t, 28000hp, 28kts, 440p; 80deck, 50shields, 75CT; 8x1-150/43, 3x1-76/40, 2x1-500TT, 120m
	Condottieri-1	7	Alberico da Barbiano	1931		6844t, 169.3x15.5x5.3m, 6b,2gt, 95000hp, 36.5kts, 520p; 24+18belt, 20deck, 23turrets, 40CT; 4x2-152/53, 3x2-100/47, 4x2-13.2, 2x2-533TT, 138m (7,9,10), 2seaplanes (M.41)
8		Alberto di Giussano	1931			
9		Bartolomeo Colleoni	1932			
10		Giovanni delle Bande Nere	1931			

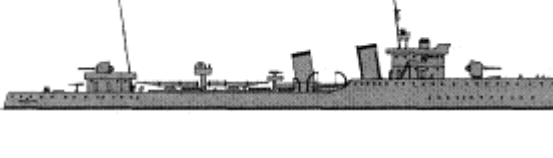

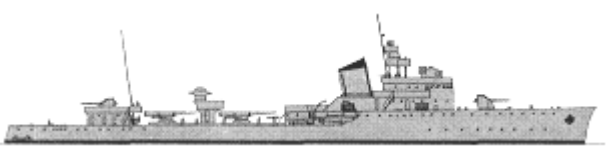
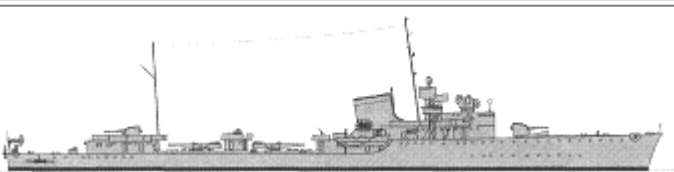

Condottieri- 2	2	11	Luigi Cadorna	1933		7001(11)-7080(12)t, 169.3x15.5x5.5m, 6b,2gt, 95000hp, 36.5kts, 544p; 24+18belt, 20deck, 40turrets, 70CT; 4x2-152/53, 3x2-100/47, 2x1-40/39, 4x2-13.2, 2x2-533TT, 2seaplanes (M.41), 138m
		12	Armando Diaz	1933		

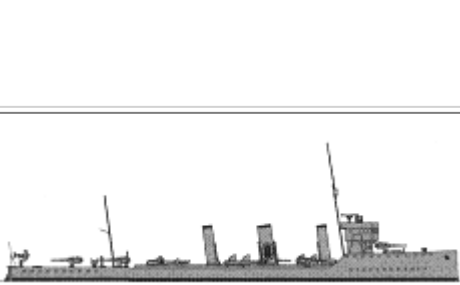
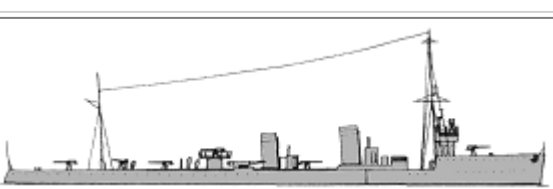
TORPEDO SHIPS





DL	Mirabello	2	1	Carlo Mirabello	1916		1972t, 103.4x9.7x3.3m, 4b,2t, 44000hp, 35kts, 169p; 8x1-102/45, 2x1-40/39, 2x2-450TT, 100m(1), 120m(2)
			2	Augusto Riboty	1917		
	Aquila	2	3	Aquila	1917		1733(3)-1760(4)t, 94.7x9.5x3.6m, 5b,2t, 40000hp, 146p; 2x2-120/45, 2x1-76/40, 2x2-450TT, 44m(3), 38m(4)
			4	Falco	1920		
	Pemuda	1	5	Pemuda	1918		2555t, 107.5x10.4x3.8m, 4b,2t, 45000hp, 34.5kts, 162p; 4x1-150/42, 1x1-120/15, 2x1-40/39, 1x2-450TT, 40m
	Rossarol	1	6	Cesare Rossarol	1915		1756t, 98.0x9.4x3.9m, 3b,2t, 30000hp, 30kts, 114p; 1x2-120/45, 2x1-76/40, 2x2-450TT, 29m
	Leone	3	7	Leone	1924		2289t, 113.4x10.3x3.2m, 4b,2t, 42000hp, 34kts, 204p; 4x2-120/45, 2x1-76/40, 2x1-40/39, 2x2-533TT, 60m
			8	Pantera	1924		
			9	Tigre	1924		
	Navigatori	12	10	Antonio da Noli	1929		2580t, 107.3x10.2x3.4m, 4b,2gt, 50000hp, 38kts, 224p; 3x2-120/50, 2x1-40/39, 4x2-13.2, 2x2-533TT, 2DCT, 56m
			11	Leone Pancaldo	1929		
			12	Luca Tarigo	1929		
			13	Antonio Usodimare	1929		
			14	Alvise da Mosto	1931		
			15	Nicoloso da Recco	1930		
			16	Giovanni di Verazzano	1930		
	17	Lanzelotto Malocello	1930				







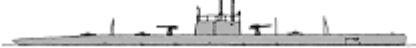

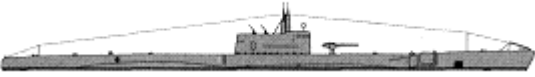

		18	Emanuele Pessagno	1930			
		19	Antonio Pigafetta	1931			
		20	Ugolini Vivaldi	1930			
		21	Nicoló Zeno	1930			
DD	Poerio	1	Alessandro Poerio	1915		1216t, 85.0x8.0x2.8m, 3b,2t, 20000hp, 31.5kts, 129p; 5x1-102/45(1), 6x1-102/45(2), 1x1-40/39(1), 2x1-40/39(2), 2x2-450TT, 42m	
		2	Guglielmo Pepe	1915			
	Ardimentoso	1	3	Ardimentoso	1916		1130t, 83.1x8.4x3.6m, 3b,2t/1t(2), 24000hp, 34kts, 111p; 3x1-100/47, 2x1-40/39, 2x2-450TT, 24m
	Palestro	4	4	Palestro	1921		1076t, 81.9x8.0x2.7m, 4b,2t, 18000hp, 32kts, 118p; 4x1-102/45, 2x1-76/40, 2x2-450TT, 38m
			5	Confienza	1923		
			6	San Martino	1922		
			7	Solferino	1921		
	Curtatone	4	8	Calatafimi	1924		1214t, 84.7x8.0x2.9m, 4b,2t, 22000hp, 32kts, 117p; 2x2-102/45, 2x1-76/30, 2x3-450TT, 16m
			9	Castelfidardo	1924		
			10	Curtatone	1923		
			11	Monzambano	1924		
	Sella	4	12	Francesco Crispi	1927		1457t, 84.9x8.6x2.7m, 3b,2gt, 36000hp, 35kts, 152p; 2x2-120/45, 2x1-40/39, 2x1-13.2, 2x2-533TT, 2DCT, 32m
			13	Quintino Sella	1926		
			14	Bettino Ricasoli	1926		
			15	Giovanni Nicotera	1927		
	Sauro	4	16	Cesare Battisti	1927		1575t, 90.2x9.2x2.9m, 3b,2gt, 36000hp, 35kts, 155p; 2x2-120/45, 2x1-40/39, 2x1-13.2, 2x3-533TT, 2DCT, 52m
			17	Daniele Manin	1927		
			18	Francesco Nullo	1927		
			19	Nazario Sauro	1926		
	Turbine	8	20	Aquilone	1927		1670t, 93.2x9.2x3.0m, 3b,2gt, 40000hp, 36kts, 179p; 2x2-120/45, 2x1-40/39, 1x2-13.2, 2x3-533TT, 52m
			21	Borea	1927		
			22	Espero	1928		
			23	Euro	1927		
24			Nembo	1927			
25			Ostro	1928			
26			Turbine	1927			
27			Zeffiro	1928			
Freccia	4	28	Dardo	1932		2116t, 94.1(28,31)-96.2(29,30)x9.8x3.2m, 3b,2gt, 44000hp, 38kts, 185p; 2x2-120/50, 2x1-40/39, 2x2-13.2, 2x3-533TT, 2DCT, 54m	
		29	Freccia	1931			
		30	Saetta	1932			
		31	Strale	1932			

TB	Folgore	4	32	Baleno	1932		2100t, 96.1x9.2x3.3m, 3b,2gt, 44000hp, 38kts, 185p; 2x2-120/50, 2x1-40/39, 2x2-13.2, 2x3-533TT, 2DCT, 54m
			33	Folgore	1932		
			34	Fulmine	1932		
			35	Lampo	1932		
	Maestrale	4	36	Grecale	1934		2207t, 106.7x10.2x3.3m, 3b,2gt, 44000hp, 38kts, 190p; 2x2-120/50, 2x1-40/39, 2x2-13.2, 2x3-533TT, 2DCT, 52m
			37	Libeccio	1934		
			38	Maestrale	1934		
			39	Scirocco	1934		
	Indomito	4	1	Indomito	1913		900t, 73.0x7.3x2.4m, 4b,2t, 16000hp, 28kts, 79p; 5x1-102/35, 1x1-40/39, 2x2-450TT, 10m
			2	Impavido	1913		
			3	Insidioso	1914		
			4	Irrequieto	1913		
	Ardito	1	5	Ardente	1914		900t, 73.0x7.3x2.4m, 4b,2t, 16000hp, 28kts, 69p; 5x1-102/35, 1x1-40/39, 2x2-450TT, 10m
Pilo	8	6	Rosolino Pilo	1915		912t, 73.0x7.3x2.3m, 4b,2t, 16000(9-12,14,16)-14800(13,15)hp, 30(9-12,14,16)-29(13,15)kts, 79p; 5x1-102/35, 2x1-40/39, 4x1-450TT, 10m	
		7	Giuseppe Cesare Abba	1915			
		8	Giuseppe Dezza	1916			
		9	Giuseppe Missori	1916			
		10	Antonio Mosto	1915			
		11	Ippolito Nievo	1915			
		12	Fratelli Cairoli	1915			
Sirtori	4	14	Giuseppe Sirtori	1916		850t, 73.5x7.3x2.8m, 4b,2t, 15500hp, 30kts, 85p; 6x1-102/45, 2x1-40/39, 2x2-450TT, 10m	
		15	Giovanni Acerbi	1917			
		16	Vincenzo Giordano Orsini	1917			
		17	Francesco Stocco	1917			
Audace	1	18	Audace	1917		1170t, 87.5x8.3x2.5m, 3b,2t, 22000hp, 30kts, 118p; 7x1-102/35, 2x1-40/39, 2x2-450TT	
La Masa	7	19	Giuseppe La Masa	1919		851t, 73.5x7.3x2.8m, 4b,2t, 15500hp, 30kts, 78p; 4x1-102/45, 2x1-76/40, 2x2-450TT, 10m	
		20	Angelo Bassini	1918			
		21	Enrico Cosenz	1919			
		22	Giacinto Carini	1917			
		23	Nicola Fabrizzi	1918			
		24	Giuseppe La Farina	1919			
25	Giacomo Medici	1918					

70OLT	1	26	75OLT	1918		195t, 45.7x4.6x1.8m, 2b,2t, 3500hp, 27kts, 31p; 2x1-76/30, 1x2-450TT, 7m
Fasana	1	27	Zenson	1914		1000t, 83.5x7.8x2.4m, 6b,2t, 20640hp, 32.6kts, 105p; 2x1-100/47, 6x1-66/47, 2x2-450TT
Grado	3	28	Cortelazzo	1917		1045t, 85.4x7.8x2.4m, 6b,2t, 22360hp, 32.6kts, 114p; 2x1-100/47, 6x1-66/47, 2x2-450TT
		29	Grado	1917		
		30	Monfalcone	1918		
Generali	6	31	Generale Antonio Cantore	1921		870t, 73.5x7.3x2.7m, 4b,2t, 15500hp, 30kts, 118p; 3x1-102/45, 2x1-76/40, 2x2-450TT, 2DCT
		32	Generale Antonio Cascino	1922		
		33	Generale Antonio Chinotto	1921		
		34	Generale Carlo Montanari	1922		
		35	Generale Achille Papa	1922		
		36	Generale Marcello Prestinari	1922		
Albatros	1	37	Albatros	1934		490t, 70.5x6.9x1.7m, 2b,2gt, 4300hp, 24.5kts, 187p; 2x1-102/35, 2x1-13.2, 4DCT, 2DCR

SUBMARINES

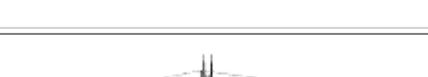
F	3	1	F6	1917		262/319t, 45.6x4.2x3.1m, 2d/em, 670/500hp, 12.5/8.2kts, 26p, 40m; 1x1-76/30, 2-450TT
		2	F13	1917		
		3	F20	1918		
H	6	4	H1	1916		364/475t, 45.8x4.7x3.8m, 2d/em, 480/620hp, 12/11kts, 22p, 50m; 1x1-76/30, 4-450TT
		5	H2	1916		
		6	H3	1917		
		7	H4	1917		
		8	H6	1917		
		9	H8	1918		
Micca	2	10	Luigi Galvani	1918		842/1244t, 63.2x6.2x4.3m, 2d/em, 2900/1800hp, 11/10.9kts, 40p, 50m; 1x1-76/40, 1x1-76/30, 6-450TT
		11	Lazzaro Mocenigo	1920		
Provana	1	12	Giacomo Nani	1919		762/924t, 67.0x5.9x3.8m, 2d/em, 2600/1400hp, 16/9.8kts, 40p, 50m; 2x1-76/40, 6-450TT

SS	N	3	13	N3	1918		277/363t, 45.8x4.3x3.2m, 2d/em, 650(13,14)-820(15)/450hp, 12.5(13,14)-13.5(15)/7.9kts, 23p, 40m; 1x1-76/30, 2-450TT	
			14	N4	1919			
			15	N6	1919			
	X2	2		16	X2	1918		403/468t, 42.6x5.5x3.2m, 2d/em, 650/325hp, 8.2/6.3kts, 25p, 40m; 1x1-76/30, 2-450TT, 18m
				17	X3	1918		
	Balilla	4		18	Balilla	1928		1427/1874t, 86.5x7.8x4.7m, 2d+1dg/em, 4900+425/2200hp, 16/7kts, 77p, 90m; 1x1-120/45, 2x2-13.2, 6-533TT, 4m(18,19,21)
				19	Domenico Millelire	1928		
				20	Antonio Sciesa	1929		
				21	Enrico Toti	1928		
	Mameli	4		22	Pier Capponi	1929		810/993t, 64.6x6.5x4.3m, 2d/em, 3000/1100hp, 15/7.5kts, 49p, 100m; 1x1-102/35, 2x1-13.2, 6-533TT
				23	Giovanni da Procida	1929		
				24	Goffredo Mameli	1929		
				25	Tito Speri	1929		
	Pisani	4		26	Giovanni Bausan	1929		866/1040t, 68.2x6.1x4.9m, 2d/em, 3000/1100hp, 15/8.2kts, 48p, 90m; 1x1-102/35, 2x1-13.2, 6-533TT
				27	Marcantonio Colonna	1929		
				28	Des Geneys	1929		
				29	Vettor Pisani	1929		
	Fieramosca	1	30	Ettore Fieramosca	1930		1530/2094t, 84.0x8.3x5.1m, 2d/em, 5200/2300hp, 15/8kts, 78p, 90m; 1x1-120/45, 2x2-13.2, 8-533TT	
	Bandiera	4		31	Fratelli Bandiera	1930		925/1080t, 69.8x7.3x5.3m, 2d/em, 3000/1300hp, 15/8kts, 53p, 90m; 1x1-102/35, 2x1-13.2, 8-533TT
				32	Luciano Manara	1930		
				33	Ciro Menotti	1930		
				34	Santore Santarosa	1930		
	Squalo	4		35	Delfino	1931		920/1125t, 69.8x7.2x5.2m, 2d/em, 3000/1300hp, 15/8kts, 53p, 90m; 1x1-102/35, 2x1-13.2, 8-533TT
				36	Narvalo	1930		
			37	Squalo	1930			
			38	Tricheco	1931			
Bragadin	2		39	Marcantonio Bragadin	1931		965/1068t, 71.5x6.2x5.0m, 2d/em, 1500/1000hp, 11.5/7kts, 55p, 90m; 1x1-102/35, 2x1-13.2, 4-533TT, 24m	
			40	Filippo Corridoni	1931			
Settembrini	2		41	Luigi Settembrini	1932		938/1135t, 69.1x6.6x4.5m, 2d/em, 3000/1400hp, 17.5/7.7kts, 56p, 90m; 1x1-102/35, 2x1-13.2, 8-533TT	
			42	Ruggiero Settimo	1932			
Argonauta	7		43	Argonauta	1932		650/800hp, 61.5x5.7x4.7m, 2d/em, 1200/800hp, 14/8kts, 44p, 80m; 1x1-102/35, 2x1-13.2, 6-533TT	
			44	Fisalia	1932			
			45	Jalea	1933			
			46	Jantina	1933			
			47	Medusa	1932			
			48	Salpa	1932			
			49	Serpente	1932			

Sirena	12	50	Ametista	1934		680/837t, 60.2x6.5x4.7m, 2d/em, 1200/800hp, 14/7.7kts, 45p, 80m; 1x1-100/47, 2x2-13.2, 6-533TT
		51	Anfitrite	1934		
		52	Diamante	1933		
		53	Galatea	1934		
		54	Naiade	1933		
		55	Nereide	1934		
		56	Ondina	1934		
		57	Rubino	1934		
		58	Sirena	1933		
		59	Smeraldo	1933		
		60	Topazio	1934		
		61	Zaffiro	1934		
Archimede	3	62	Archimede	1934		970/1239t, 70.5x6.9x4.1m, 2d/em, 3000/1100hp, 17/8kts, 55p, 90m; 2x1-100/43, 2x1-13.2, 8-533TT
		63	Galileo Galilei	1934		
		64	Evangelista Torricelli	1934		



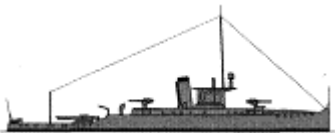



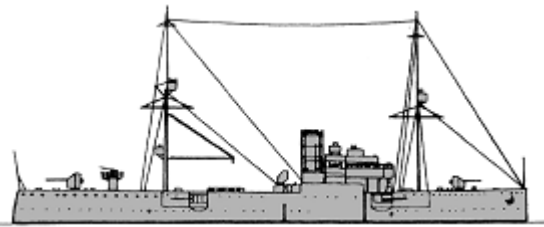
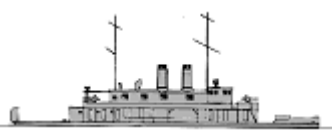



ESCORTS

PC	Bafile	5	1	Andrea Bafile	1922		284t, 52.1x5.7x1.8m, 2b,2vte, 2400hp, 24kts, 53p; 2x1-102/35, 1x2-450TT, 12m
			2	Carlo del Greco	1922		
			3	Tolosetto Farinati	1922		
			4	Ernesto Giovannini	1922		
			5	Alessandro Vitturi	1922		
APC	-	18	1	Cirene	1912		500t; 2x1-76/40
			2	Porto Corsini	1912		380t; 2x1-76/40
			3	Rimini	1912		420t; 2x1-76/40
			4	Alula	1912		430t; 1x1-76/40
			5	Gallipoli	1911		400t; 2x1-76/40
			6	Otranto	1911		385t; 2x1-76/40
			7	Valoroso	1913		420t; 2x1-76/40
			8	Balena	1911		286t; 1x1-76/40
			9	Basiluzzo	1915		110t
			10	Burrasca	1912		280t; 1x1-76/40
			11	Gaeta	1916		250t; 1x1-76/40
			12	Lampedusa	1915		166t; 1x1-76/40
			13	Lilibeo	1915		124t
			14	Liscanera	1916		222t; 1x1-76/40
			15	Porto d' Anzio	1914		166t; 1x1-76/40
			16	Portofino	1915		270t; 1x1-76/40
			17	Talamone	1916		190t; 1x1-76/40



OTHER FIGHTING SHIPS



PG	Sebastiano Caboto	1	1	Sebastiano Caboto	1912	No picture	1050t, 63.4x9.7x3.0m, 2b,2vte, 1200hp, 13.2kts, 107p; 6x1-76/40
	Campania	1	2	Campania	1917		3187t, 83.0x12.7x5.2m, 4b,2vte, 5000hp, 15.7kts, 204p; 25deck, 50CT; 2x1-152/40, 5x1-76/40
APG	-	3	1	Abisso	1912		400t; 2x1-76/40
			2	Boeo	1916		235t; 1x1-76/40
			3	Palmaiola	1902		562t; 1x1-76/40
PR	Carlotto	1	1	Ermanno Carlotto	1921		218t, 48.8x7.5x0.9m, 2b,2vte, 1100hp, 14kts, 44p; 2x1-76/40

COASTAL FORCES

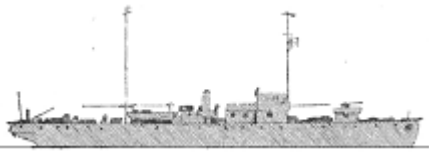
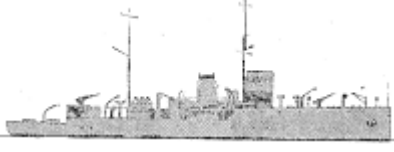
PT	12t A-1 SVAN	1	1	MAS15	1916		16t, 16.0x2.6x1.2m, 2pe/em, 450/10hp, 23/4kts, 8p; 2-450TT, 1DCR
	12t A-1 Orlando	2	2, 3	MAS94, 100	1917 - 1918		13t, 16.2x2.8x1.4m, 2pe/em, 500/10hp, 29.5/4kts, 8p; 2-450TT, 1DCR
	12t A-1 Baglietto	6	4 - 9	MAS204, 206, 210, 212, 213, 216	1918		14t, 16.0x2.6x1.1m, 2pe, 700hp, 27kts, 7p; 2-450TT, 2DCR
	12t A-2 Orlando	6	10 - 15	MAS219, 222, 223, 228-230	1918		13t, 16.4x2.9x1.4m, 2pe/em(10,11,13)-2pe(12,14,15), 500/10(10,11,13)-500(12,14,15)hp, 26/4(10,11,13)-26(12,14,15)kts, 8p; 2-450TT, 1DCR
	D-1 Baglietto	4	16 - 19	MAS397-400	1920 - 1924		27t, 21.2x4.2x1.2m, 3pe/2em(3), 1900/10hp, 33/4kts, 12p; 2-450TT, 2DCR
	D-2 SVAN	2	20, 21	MAS418, 422	1922 - 1923		21t, 18.0x3.6x1.2m, 3pe/2em(3), 1200/16hp, 26.5/5kts, 10p; 2-450TT, 1DCR
	SVAN 1923	3	24 - 26	MAS427-429	1925 - 1927	No picture	31(24,25)-30(26)t, 24.0(24,25)-22.0(26)x4.0x1.3m, 3pe, 1200hp, 26(24,25)-28(26)kts, 11p; 1x1-76/30, 2-450TT, 2DCR
	13t SVAN	3	27 - 29	MAS423-426	1928 - 1930		13t, 16.0x3.0x1.0m, 2pe, 1500hp, 40kts, 9p; 2-450TT
	14t SVAN	7	30 - 36	MAS430, 432 - 437	1929 - 1934		14(31-35)-19(36)t, 16.0(31-35)-17.5(36) x3.3(31-35)-3.6(36) x1.0(31)-1.1(32-35)-1.3(36)m, 2pe(31-35)-2d(36), 1500hp, 40kts, 9(31)-13(32-35)p; 2-450TT, 1DCR
	14t Baglietto	1	37	MAS431	1932		16t, 16.0x4.0x1.3m, 2pe, 1500hp, 41kts, 7p; 2-450TT, 1DCR
PG	12t mod. A-1 SVAN	1	1	MAS188	1918		12t, 16.0x2.6x1.1m, 2pe, 480hp, 25kts, 8p; 1x1-57/43, 1DCR
PS	40t Baglietto	2	1, 2	MAS438, 439	1934	No picture	41t, 22.5x4.3x1.4m, 2pe, 2000hp, 32kts, 19p; 1x1-76/40, 2DCR

MINE WARFARE SHIPS

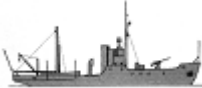
ML	Fasana	4	1	Fasana	1925		590t, 66.3x9.8x1.7m, 2d, 700hp, 10kts, 66p; 1x1-76/40, 54m, MS
			2	Durazzo	1926		
			3	Buccari	1927		
			4	Pelagosa	1927		
	Ostia	6	5	Dardanelli	1926		850t, 62.2x8.7x2.6m, 2b,2vte, 1500hp, 15kts, 66p; 2x1-102/35, 1x1-76/40, 80m, MS
			6	Milazzo	1926		
			7	Ostia	1926		
			8	Legnano	1927		
			9	Azio	1928		
			10	Lepanto	1928		
MS	RD1	38	1	RD4	1917		196-302t, 34.0-38.0x5.8-7.2x1.9-2.5m, 1b,1vte, 590-1150hp, 10-14kts, 22p; 1x1-76/40, MS
			2	RD6	1917		
			3	RD7	1917		
			4	RD9	1917		
			5	RD12	1917		
			6	RD13	1918		
			7	RD16	1917		
			8	RD17	1917		
			9	RD18	1917		
			10	RD20	1917		
			11	RD21	1918		
			12	RD22	1918		
			13	RD23	1918		
			14	RD24	1918		
			15	RD25	1918		
			16	RD26	1918		
			17	RD27	1918		
			18	RD28	1918		
			19	RD29	1919		
			20	RD30	1919		
			21	RD31	1919		
			22	RD32	1919		
			23	RD33	1919		
			24	RD34	1919		
			25	RD35	1919		
			26	RD36	1919		
			27	RD37	1920		
			28	RD38	1921		
			29	RD39	1919		

			30	RD40	1920		
			31	RD41	1920		
			32	RD42	1920		
			33	RD43	1920		
			34	RD44	1920		
			35	RD49	1922		
			36	RD55	1925		
			37	RD56	1925		
			38	RD57	1926		
	RD58	3	39	Albona	1920		145t, 31.8x6.5x1.7m, 1b,2vce, 280hp, 11kts, 27p; 1x1-76/40, 34m, MS
40			Laurana	1920			
41			Rovigno	1920			
	Meteo	2	42	Vieste	1918		560t, 59.6x7.3x2.2m, 2b,2vte, 1850hp, 16kts, 40p; 2x1-105/42, 30m, MS
43			Crotone	1918			
AMS	-	4	1	Pellegrino Matteucci	1924		620t; 1x1-76/40
			2	Mario Sonzini	1924		620t; 1x1-76/40
			3	Giovanni Berta	1924		620t; 1x1-76/40
			4	Giuseppe Biglieri	1924		620t; 1x1-76/40

NAVAL AVIATION (approximately, maximal number of delivered planes signed)

Seaplanes	F: 100 M.7ter, 29 M.7ter AR, 46 CR.20idro, 25 M.41bis, 10 M.71; B: ~20 M.18, ~20 M.18 AR; R: 15 P.6ter
-----------	--



[home](#)

[World navies yesterday](#)

[1935](#)

Japan 01 January 1935

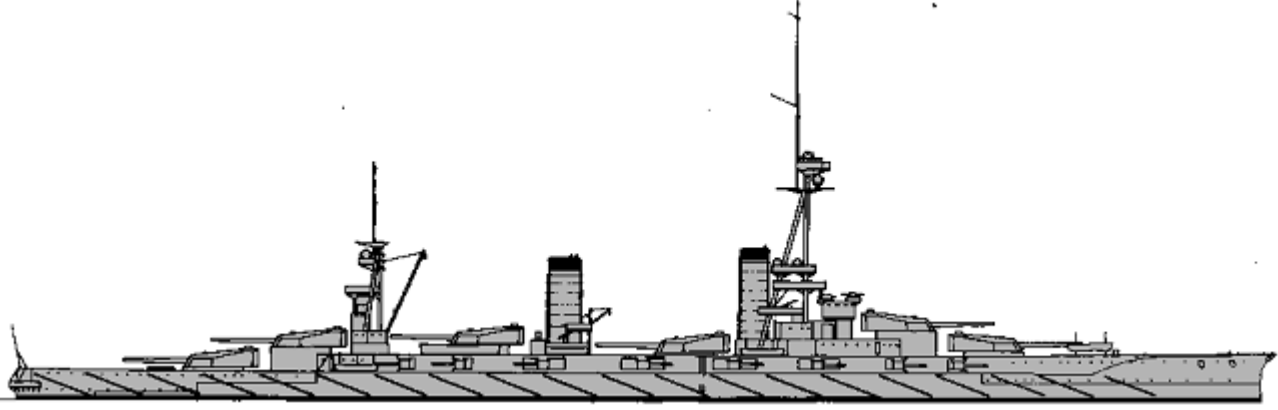
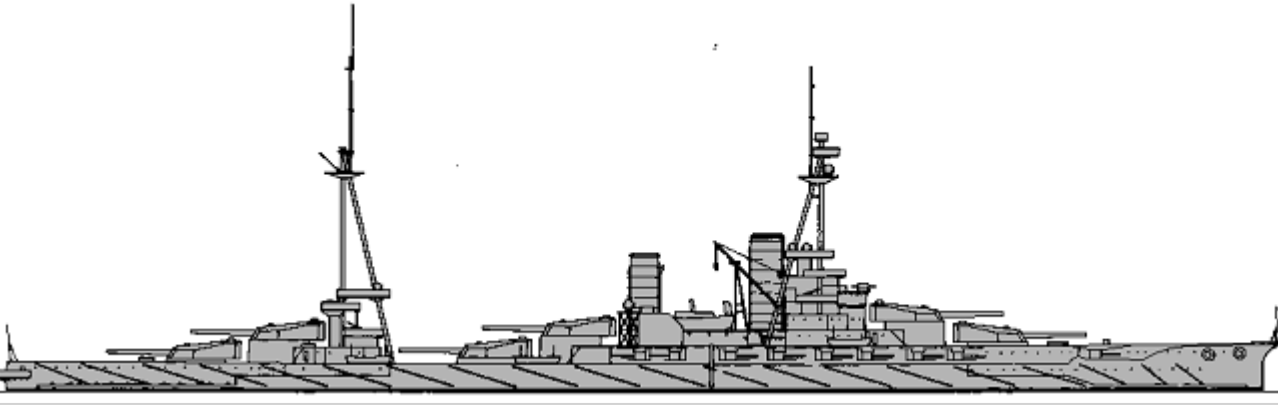
CAPITAL SHIPS AND MONITORS

		1	Fuso	1915		<p>39154t, 205.1x33.1(1)-28.7(2)x8.7m, 24b,4t, 40000hp, 22.5kts, 1193p; 305belt, 97(1)-76(2)deck, 305turrets, 350CT; 6x2-256/45, 14x1-152/50(1), 16x1-152/50(2), 4x2-127/40(1), 6x1-76/40(2), 8x1-13.2(1), 6-533TT</p>
Fuso	2	2	Yamashiro	1917		
BB	Ise	3	Ise	1917		<p>36500t, 208.2x28.7x8.8m, 24b,4t, 45000hp, 23kts, 1360p; 305belt, 51deck, 305turrets, 305CT; 6x2-356/45, 20x1-140/50, 4x1-76/40, 6-533TT, 3seaplanes (E2N1)</p>
		4	Hyuga	1918		
Nagato	2	5	Nagato	1920		<p>38500t, 215.8x29.0x9.1m, 21b,4gt, 80000hp, 26.5kts, 1333p; 305belt, 121deck, 356turrets, 356CT; 4x2-410/45, 20x1-140/50, 4x2-127/40, 2x1-40/62, 8-533TT</p>
		6	Mutsu	1921		

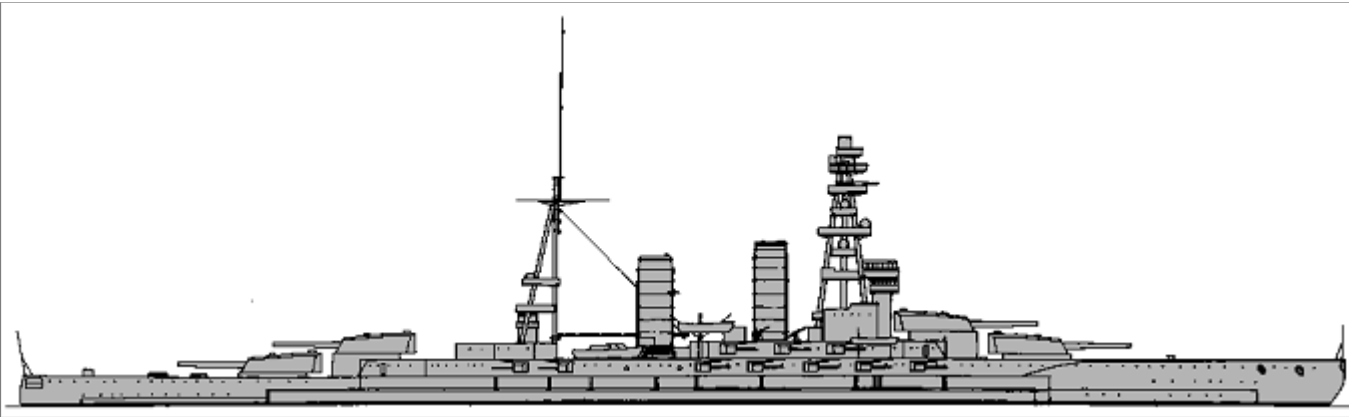
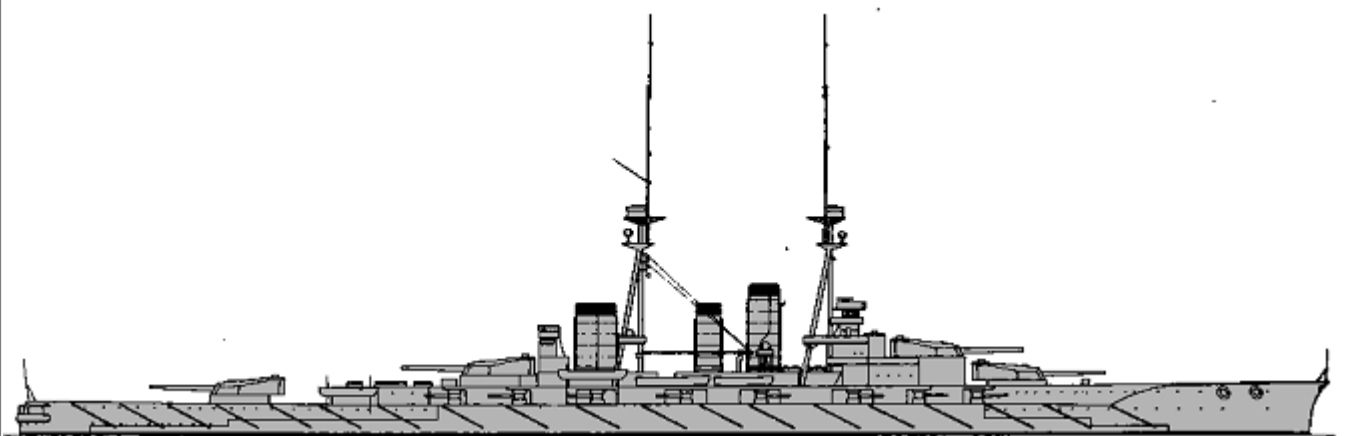
						
CB	Kongo	1	Kongo	1913		31785(1,3)-25000(2)-36601(4)t, 215.2(1-3)-222.1(4)x29.3x8.7(1-3)-9.7(4)m, 10b(1,3)-11b(2,4),4t(1-3)-4gt(4), 64000(1,3)-13800(2)-136000(4)hp, 25.9(1,3)-18(2)-30.5(4)kts, 1118(1-3)-1437(4)p; 203belt(1,3,4), 80deck, 229turrets, 254CT; 4x2-356/45(1,3,4), 3x2-356/45(2), 16x1-152/50(1,3), 14x1-152/50(4), 4x2-127/40(4), 8x1-76/40(2), 4x1-40/62(1,3), 8x1-13.2(1,3), 4x2-13.2(4), 4-533TT(1,3,4), 3seaplanes (E2N1(1,3) or E7K2(4))
		2	Hiei (TS)	1914		
		3	Kirishima	1915		
		4	Haruna	1915		

AIRCRAFT CARRYING SHIPS

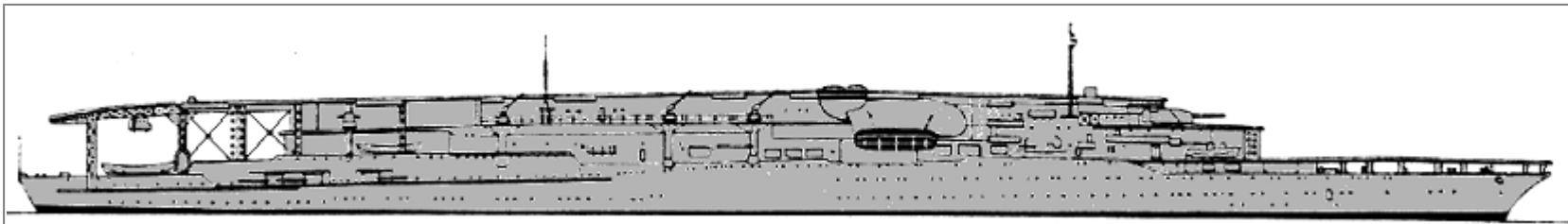
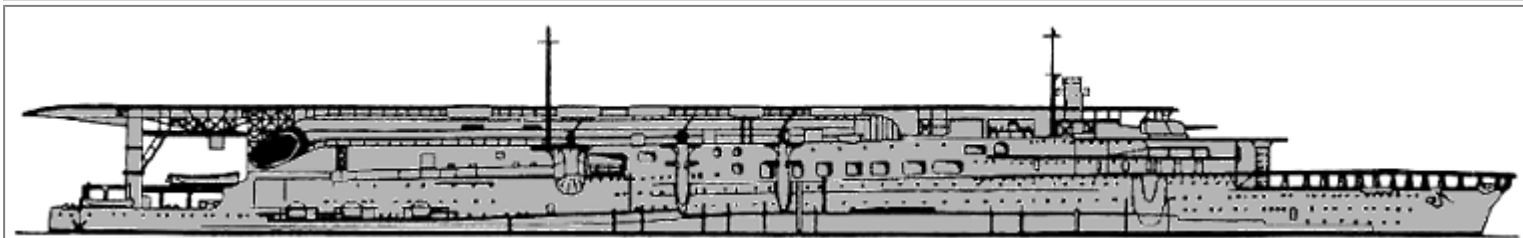
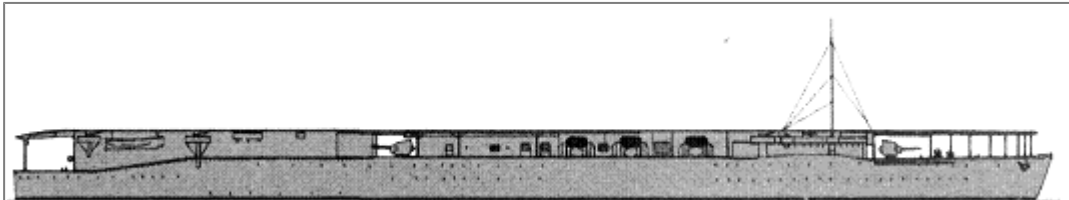

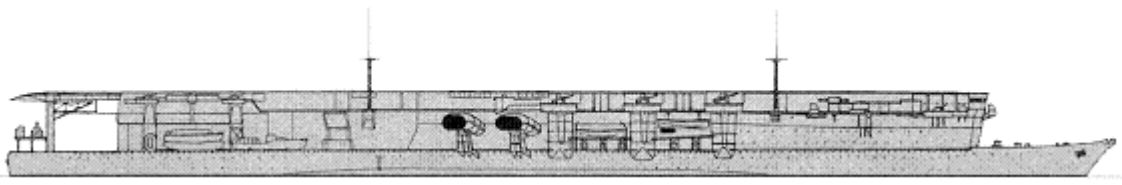
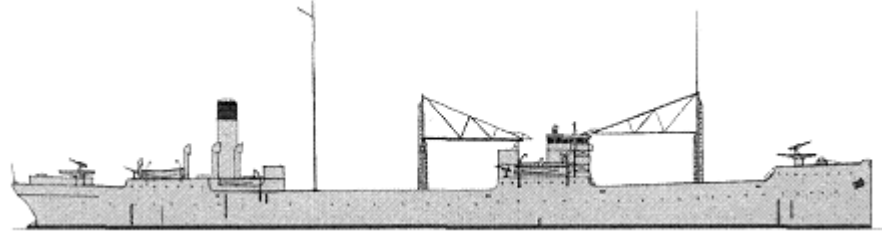
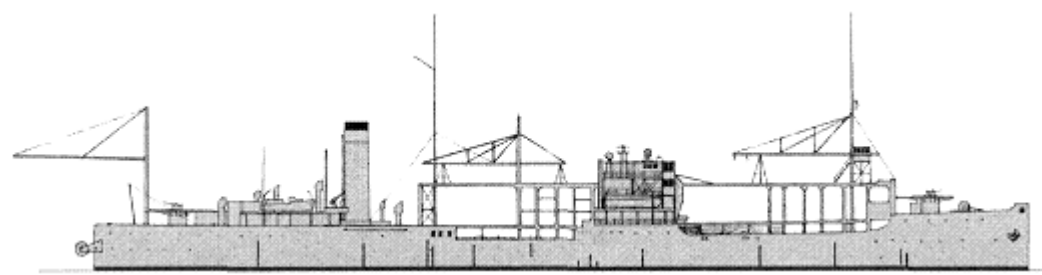
CV	Akagi	1	1	Akagi	1927		34364t, 260.7x29.0x8.1m, 19b,4gt, 131200hp, 31kts, 1650p; 152belt, 51deck, 25turrets; (2x2+6x1)-200/50, 6x2-120/45, 60aircraft (16 A2N, 28 B2M, 16 D1A)
	Kaga	1	2	Kaga	1928		33693t, 238.5x29.6x7.9m, 12b,4gt, 91000hp, 27.5kts, 1340p; 152belt, 55deck, 25turrets; (2x2+6x1)-200/50, 6x2-120/45, 60aircraft (really no)
CVL	Hosho	1	1	Hosho	1922		9630t, 168.1x22.7x6.2m, 8b,2t, 30000hp, 25kts, 550p; 4x1-140/50, 4x1-76/40, 26aircraft (9 A2N, 9 B3Y)
							10150t, 179.9x23.0x5.6m, 6b,2gt,

	Ryujo	1	2	Ryujo	1933		65000hp, 29kts, 600p; 6x2-127/40, 48aircraft (5 A1N, 12 B1M)
AV	Notoro	1	1	Notoro	1920		14050t, 138.9x17.7x8.1m, 4b,2vte, 5850hp, 12kts, 155p; 2x1-120/45, 2x1-76/40, 10seaplanes (E2N, E4N, E7K)
	Kamoi	1	2	Kamoi	1922		19240t, 151.2x20.4x8.4m, 2b,2tg,2em, 9000hp, 15kts; 2x1-140/50, 2x1-76/40, 2x2-13.2, 12seaplanes (E2N, E4N, E7K)

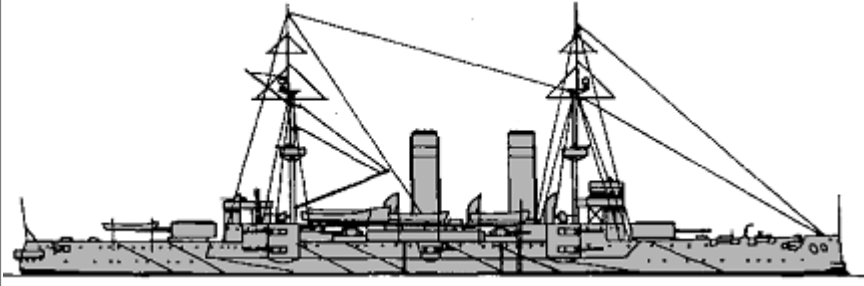
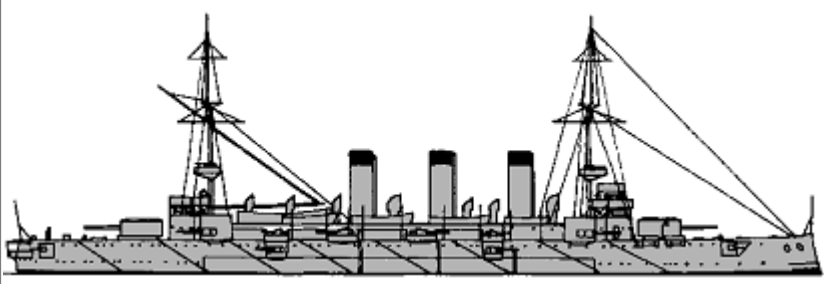
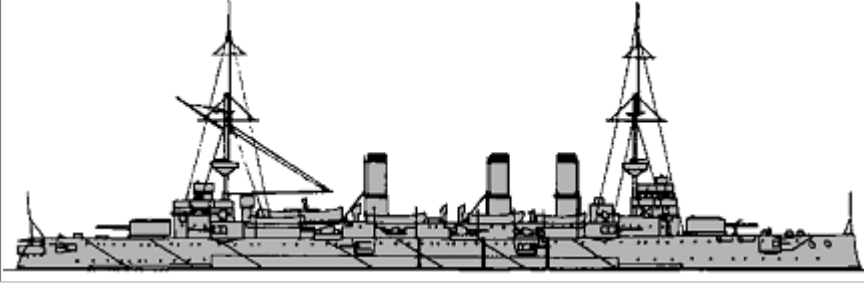
CRUISERS



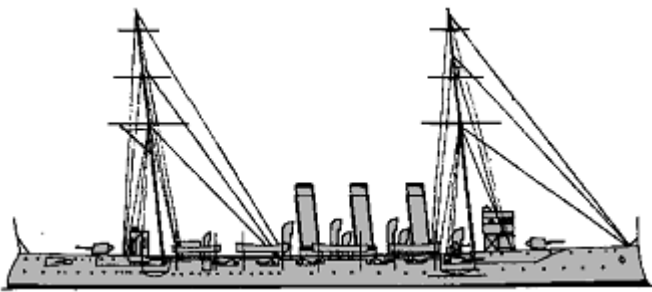
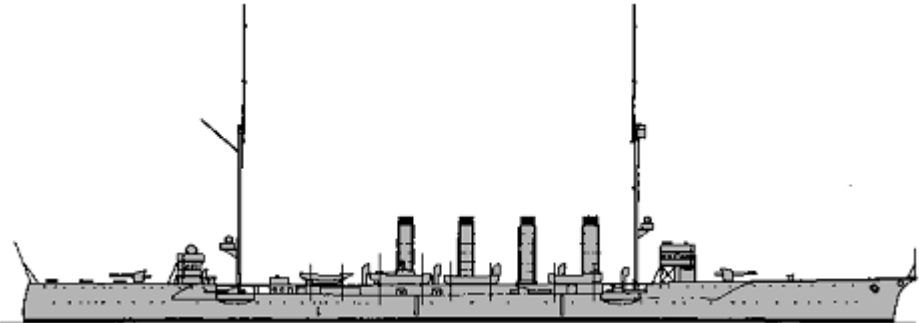
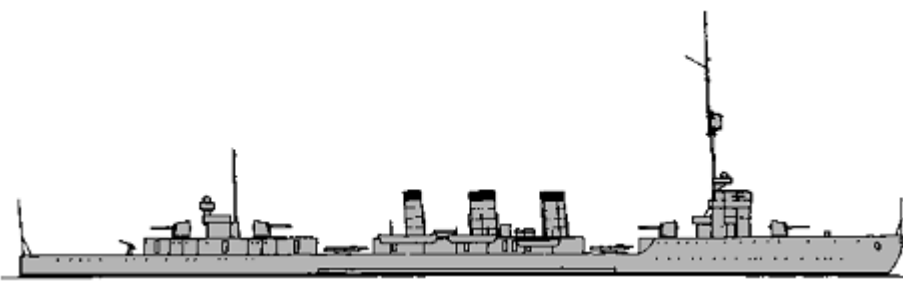
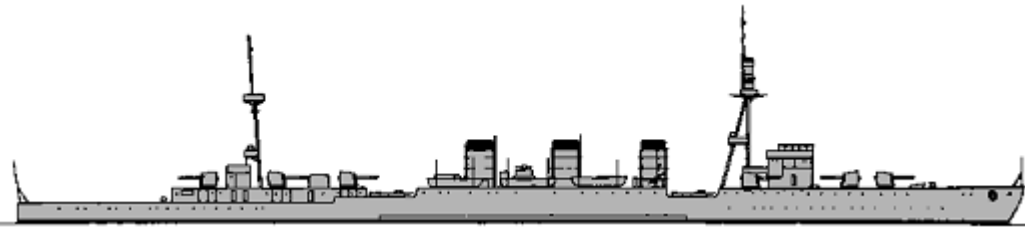
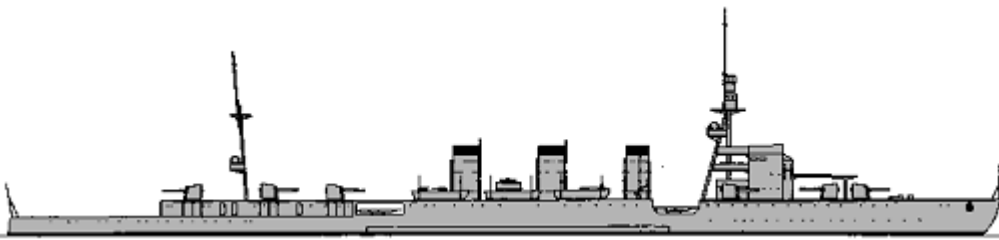
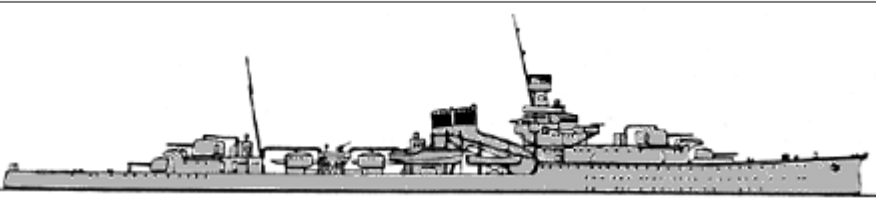

	Asama	1	1	Asama	1899		10500t, 134.7x20.5x7.4m, 6b,2vte, 7000hp, 16kts, 726p; Harvey: 178belt, 76deck, 152turrets, 356CT; 2x2-203/45, 14x1-152/40, 5x1-76/40
	Yakumo	1	2	Yakumo	1900		10300t, 132.3x19.6x7.2m, 6b,2vte, 7000hp, 16kts, 700p; 178belt, 63deck, 152turrets, 356CT; 2x2-203/45, 8x1-152/40, 1x1-76/40
	Azuma	1	3	Azuma (TS)	1900		9953t, 137.9x20.9x7.2m, 6b,2vte, 9400hp, 16kts, 650p; 178belt, 63deck, 152turrets, 356CT; 2x2-203/45, 8x1-152/40, 5x1-76/40

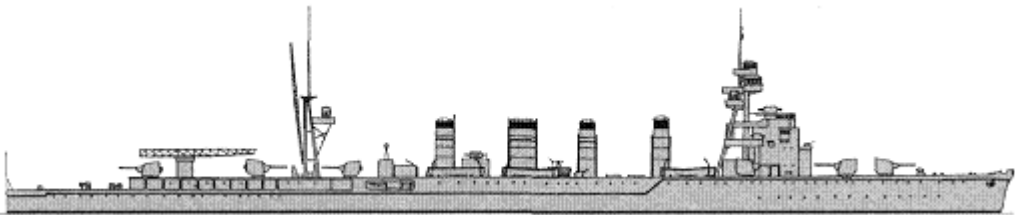
CA	Izumo	4	Izumo	1900		10300t, 132.3x20.9x7.4m, 24b(1)-6b(2),2vte, 14500(1)-7000(2)hp, 20.8(1)-16(2)kts, 672p; 178belt, 63deck, 152turrets, 356CT; 2x2-203/45, 14x1-152/40(1), 8x1-152/40(2), 9x1-76/40(1), 5x1-76/40(2), 4x1-47/30(1), 2-450TT(1)	
		5	Iwate	1901			
	Kasuga	6	Kasuga	1904		8500t, 111.7x18.9x7.3m, 12b,2vte, 13500hp, 20kts, 600p; 150belt, 38deck, 150turrets, 150CT; 1x1-254/40(6), 1x2-203/45(6), 2x2-203/45(7), 4x1-152/40, 5x1-76/40, 4-450TT	
		7	Nisshin	1904			
	Furutaka	8	Furutaka	1926		9544t, 185.2x15.8x5.6m, 12b,4gt, 102000hp, 34.5kts, 625p; 76belt, 35deck, 25turrets; 6x1-200/50, 4x1-120/45, 2x2-13.2, 12-610TT, 2seaplanes(E2N/E4N/E7K)	
		9	Kako	1926			
	Aoba	10	Aoba	1927		9820t, 185.2x15.8x5.7m, 12b,4gt, 102000hp, 34.5kts, 625p; 76belt, 35deck, 25turrets; 3x2-200/50, 4x1-120/45, 2x4-13.2, 12-610TT, 1seaplane (E2N)	
		11	Kinugasa	1927			
	Nachi	4	12	Nachi	1928		13280t, 203.8x17.3x5.9m, 12b,4gt, 130000hp, 35.5kts, 773p; 102belt, 90deck, 25turrets; 5x2-203/50, 6x1-120/45, 12-610TT, 2seaplanes (E2N)
			13	Myoko	1929		
14			Haguro	1929			
15			Ashigara	1929			
Takao	4	16	Takao	1932		14260t, 203.8x19.0x6.1m, 12b,4gt, 130000hp, 35.5kts, 773p; 102belt, 90deck, 25turrets, 16CT; 5x2-203/50, 4x1-120/45, 2x1-40/62, 4x2-610TT, 3seaplanes (2 E4N, 1 E7K)	
		17	Atago	1932			
		18	Maya	1932			
		19	Chokai	1932			
	Tsushima	1	Tsushima	1904		3716t, 104.1x13.4x4.9m, 16b,2vte, 9500hp, 20kts, 320p; Harvey: 64deck, 25shields, 102CT; 6x1-152/40, 9x1-76/40	



CL							
	Chikuma	2	Hirado	1912		5040t, 144.8x14.2x5.1m, 6b,2t, 22500hp, 26kts, 414p; 89belt, 57deck, 25shields, 102CT; 8x1-152/45, 4x1-76/40(2), 5x1-76/40(3), 2x2-533TT	
		3	Yahagi	1912			
	Tenryu	4	Tenryu	1919		4350t, 142.9x12.3x4.0m, 10b,3gt, 51000hp, 33kts, 327p; 63belt, 25deck, 20shields, 51CT; 4x1-140/50, 1x1-76/40, 2x3-533TT, 48m	
		5	Tatsuta	1919			
	Kuma	6	Kuma	1920		5832t, 162.2x14.2x4.8m, 12b,4gt, 90000hp, 36kts, 450p; 63belt, 29deck, 20shields, 51CT; 7x1-140/50, 2x1-76/40(6,8-10), 2x2-13.2(7), 4x2-533TT, 48m, 1seaplane (E4N or E7K, 6,7)	
		7	Tama	1921			
		8	Kitakami	1921			
		9	Oi	1921			
		10	Kiso	1921			
	Nagara	11	Nagara	1922		7050t, 162.2x14.2x4.8m, 12b,4gt, 90000hp, 36kts, 450p; 63belt, 29deck, 20shields, 51CT; 7x1-140/50, 2x1-76/40, 1x4-13.2, 4x2-610TT, 48m, 1seaplane (E2N or E4N or E7K)	
		12	Isuzu	1923			
		13	Natori	1922			
		14	Yura	1923			
		15	Kinu	1922			
		16	Abukuma	1925			
	Yubari	1	17	Yubari	1923		4400t, 138.9x12.0x3.6m, 8b,3gt, 57750hp, 35.5kts, 328p; 57belt, 25deck, 25turrets; (2x2+2x1)-140/50, 2x2-610TT, 48m
			18	Sendai	1924		7100t, 163.0x14.2x4.9m, 12b,4gt, 90000hp, 35.2kts, 450p; 64belt, 29deck, 20shields; 7x1-140/50, 2x1-76/40(18,19),
			19	Naka	1925		

Sendai	3	20	Jintsu	1925		(1x4+2x1)-13.2(20), 4x2-610TT, 48m, 1seaplane (E2N or E4N or E7K)
--------	---	----	--------	------	---	---

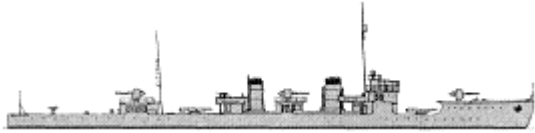

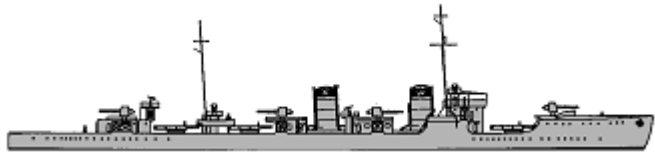
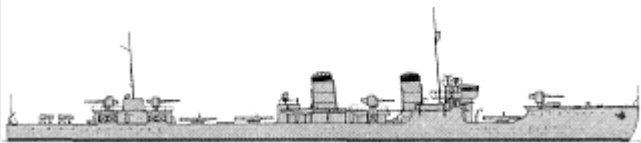
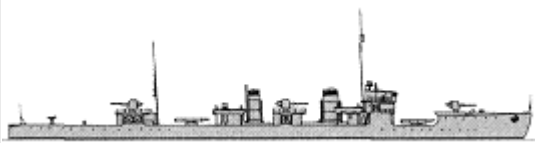

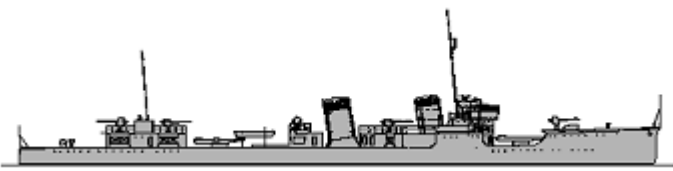
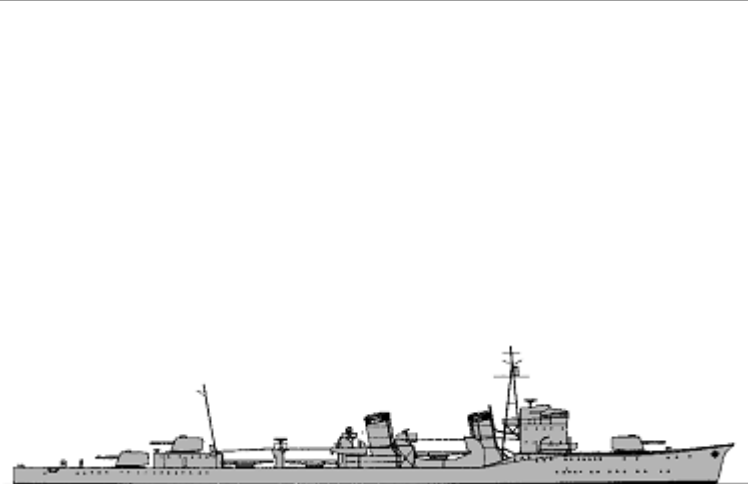
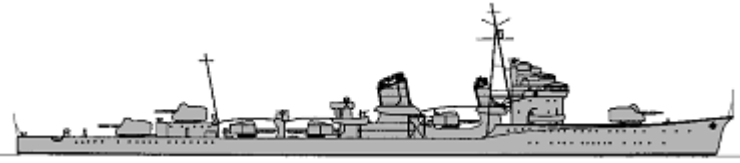

TORPEDO SHIPS



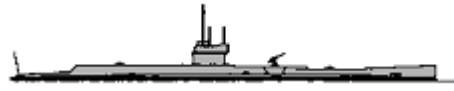

Urakaze	1	1	Urakaze	1915		1085t, 87.2x8.4x2.4m, 3b,2t, 22000hp, 30kts, 120p; 1x1-120/40, 4x1-76/40, 2x2-533TT
Momo	4	2	Momo	1916		1080t, 85.6x7.7x2.3m, 4b,2gt, 16000hp, 31.5kts, 110p; 3x1-120/40, 2x3-450TT
		3	Kashi	1917		
		4	Hinoki	1917		
		5	Yanagi	1917		
Amatsukaze	4	6	Amatsukaze	1917		1570t, 96.9x8.5x2.8m, 5b,3t, 27000hp, 34kts, 128p; 4x1-120/40, 3x2-450TT
		7	Isokaze	1917		
		8	Tokitsukaze	1917		
		9	Hamakaze	1917		
Kawakaze	1	10	Tanikaze	1919		1580t, 103.6x8.8x2.8m, 4b,2t, 34000hp, 37.5kts, 128p; 3x1-120/45, 2x3-533TT
Momi	19	11	Kaya	1920		1020t, 85.3x7.9x2.4m, 3b,2gt, 21500hp, 36kts, 110p; 3x1-120/45, 2x2-533TT, 20m, MS
		12	Nire	1920		
		13	Nashi	1919		
		14	Take	1919		
		15	Kaki	1920		
		16	Kuri	1920		
		17	Tsuga	1920		
		18	Fuji	1921		
		19	Kiku	1920		
		20	Aoi	1920		
		21	Hagi	1921		
		22	Susuki	1921		
		23	Ashi	1921		
		24	Tsuta	1921		
25	Hasu	1922				
26	Hishi	1922				
27	Sumire	1923				

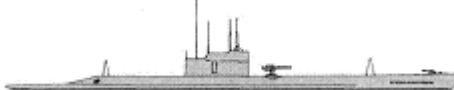
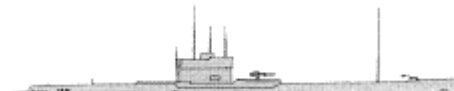
		28	Yomogi	1922		
		29	Tade	1922		
Minekaze	15	30	Minekaze	1920		1650t, 102.6x9.0x2.9m, 4b,2gt, 38500hp, 39kts, 148p; 4x1-120/45, 3x2-533TT, 20m
		31	Sawakaze	1920		
		32	Okikaze	1920		
		33	Hakaze	1920		
		34	Yakaze	1920		
		35	Nadakaze	1921		
		36	Shimakaze	1920		
		37	Akikaze	1921		
		38	Shiokaze	1921		
		39	Yukaze	1921		
		40	Hokaze	1921		
		41	Tachikaze	1921		
		42	Nokaze	1922		
		43	Namikaze	1922		
		44	Numakaze	1922		
Kamikaze	9	45	Kamikaze	1922		1720t, 102.6x9.1x2.9m, 4b,2gt, 38500hp, 37.2kts, 148p; 4x1-120/45, 3x2-533TT, 20m, MS
		46	Asakaze	1923		
		47	Harukaze	1923		
		48	Matsukaze	1924		
		49	Hatakaze	1924		
		50	Oite	1925		
		51	Hayate	1925		
		52	Asanagi	1925		
		53	Yunagi	1925		
Wakatake	7	54	Wakatake	1922		1100t, 85.3x7.9x2.5m, 3b,2gt, 21500hp, 35.5kts, 110p; 3x1-120/45, 2x2-533TT, 20m, MS
		55	Kuretake	1922		
		56	Sanae	1923		
		57	Asagao	1923		
		58	Yugao	1924		
		59	Fuyo	1923		
		60	Karukaya	1923		
Mutsuki	12	61	Mutsuki	1926		1772t, 102.7x9.2x3.0m, 4b,2gt, 38500hp, 37.2kts, 150p; 4x1-120/45, 2x3-610TT, 2DCT, 16m, MS
		62	Kisaragi	1925		
		63	Yayoi	1926		
		64	Uzuki	1926		
		65	Satsuki	1925		
		66	Minazuki	1927		
		67	Fumizuki	1926		

		68	Nagatsuki	1927		
		69	Kikuzuki	1926		
		70	Mikazuki	1927		
		71	Mochizuki	1927		
		72	Yuzuki	1927		
		73	Fubuki	1928		
Fubuki	19	74	Shinonome	1928		
		75	Usugumo	1928		
		76	Shirakumo	1928		
		77	Isonami	1928		
		78	Shirayuki	1928		
		79	Hatsuyuki	1929		
		80	Murakumo	1928		
		81	Uranami	1929		
		82	Shikinami	1929		
		83	Ayanami	1930		
		84	Asagiri	1930		
		85	Sagiri	1931		
		86	Yugiri	1930		
		87	Amagiri	1930		
		88	Oboro	1931		1980t, 118.4x10.4x3.3m, 3b,2gt, 50000hp, 38kts, 197p; 3x2-127/50, 2x1-13.2, 3x3-610TT, 2DCT, 18m
Akatsuki	4	92	Akatsuki	1932		
		93	Hibiki	1933		
		94	Ikazuchi	1932		
		95	Inazuma	1932		
Hatsuharu	4	96	Hatsuharu	1933		2240t, 109.5x10.0x3.0m, 3b,2gt, 42000hp, 33.3kts, 200p; (2x2+1x1)-127/50, 2x1-13.2, 2x3-610TT, 2DCT
		97	Nenohi	1933		
		98	Hatsushimo	1934		
		99	Wakaba	1934		
TB Chidori	4	1	Chidori	1933		737t, 82.0x7.4x2.5m, 2b,2gt, 11000hp, 30kts, 113p; (1x2+1x1)-127/50, 1x1-40/62, 2x2-533TT, 2DCT
		2	Tomozuru	1934		
		3	Manazuru	1934		
		4	Hatsukari	1934		

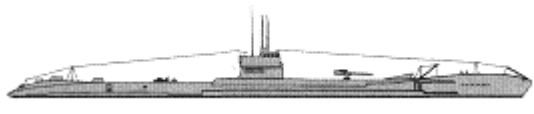
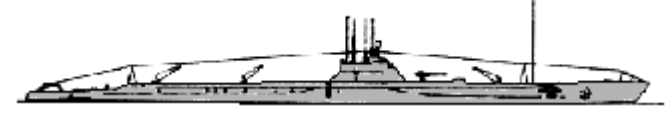
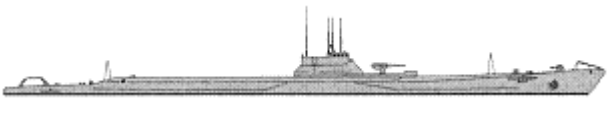
SUBMARINES

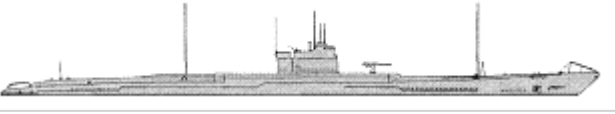
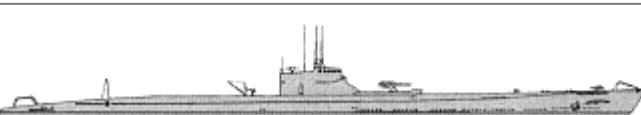
SS	L-1	1	1	RO51	1920		893/1195t, 70.6x7.2x3.9m, 2d/em, 2400/1600hp, 17/8kts, 48p, 60m; 1x1-76/23, 6-450TT
	K-3	4	2	RO16	1922		755/1050t, 70.1x6.1x3.7m, 2d/em, 2600/1200hp, 17/9kts, 45p, 45m; 1x1-76/23, 4-450TT, 2-450TR
			3	RO18	1921		
			4	RO19	1922		
			5	RO25	1921		
	L-2	4	6	RO53	1921		893/1195t, 70.6x7.1x3.9m, 2d/em, 2400/1600hp, 17/8kts, 48p, 60m; 1x1-76/23, 4-450TT
			7	RO54	1921		
			8	RO55	1921		
			9	RO56	1922		
	L-3	3	10	RO57	1922		897/1195t, 76.2x7.2x4.0m, 2d/em, 2400/1600hp, 17/8kts, 48p, 60m; 1x1-76/40, 4-533TT
			11	RO58	1922		
			12	RO59	1923		
	K-4	3	13	RO26	1923		770/1080t, 74.2x6.1x3.7m, 2d/em, 2600/1200hp, 17/9kts, 45p, 45m; 1x1-76/23, 4-533TT
			14	RO27	1924		
			15	RO28	1923		
	KT	4	16	RO29	1923		665/1030t, 74.2x6.1x3.7m, 2d/em, 1200/1200hp, 13/8kts, 43p, 75m; 1x1-120/45, 4-533TT
			17	RO30	1924		
			18	RO31	1927		
			19	RO32	1924		
	L-4	9	20	RO60	1923		996/1322t, 76.2x7.4x3.8m, 2d/em, 2400/1600hp, 16.5/9kts, 47p, 60m; 1x1-76/40, 6-533TT
			21	RO61	1924		
			22	RO62	1924		
			23	RO63	1924		
			24	RO64	1925		
			25	RO65	1926		
			26	RO66	1927		
			27	RO67	1926		
			28	RO68	1925		
KD-1	1	29	I51	1924		1500/2430t, 91.4x8.8x4.6m, 2d/em, 2600/1000hp, 14.5/6.2kts, 60p, 60m; 1x1-120/45, 8-533TT	
KD-2	1	30	I52	1925		1500/2500t, 100.9x7.6x5.1m, 2d/em, 6800/2000hp, 22/10kts, 60p, 60m; 1x1-120/45, 1x1-76/40, 8-533TT	
J-1	4	31	I1	1926		2135/2791t, 97.5x9.2x5.0m, 2d/em, 6000/2600hp, 18/8kts, 92p, 80m; 2x1-140/40, 6-533TT	
		32	I2	1926			
		33	I3	1926			





			34	I4	1929		
KD-3a	4		35	I53	1927		1800/2300t, 100.6x8.0x4.8m, 2d/em, 6800/1800hp, 20/8kts, 64p, 60m; 1x1-120/45, 8-533TT
			36	I54	1927		
			37	I55	1927		
			38	I58	1928		
KRS	4		39	I21	1927		1383/1768t, 85.2x7.5x4.4m, 2d/em, 2400/1100hp, 14.5/7kts, 51p, 75m; 1x1-140/40, 4-533TT, 42m
			40	I22	1927		
			41	I23	1928		
			42	I24	1928		
KD-3b	5		43	I56	1929		1800/2300t, 101.0x7.9x4.9m, 2d/em, 6800/1800hp, 20/8kts, 79p, 60m; 1x1-120/45, 8-533TT
			44	I57	1929		
			45	I59	1930		
			46	I60	1929		
			47	I63	1928		
KD-4	3		48	I61	1929		1720/2300t, 97.7x7.8x4.8m, 2d/em, 6000/1800hp, 20/8.5kts, 58p, 60m; 1x1-120/45, 6-533TT
			49	I62	1930		
			50	I63	1930		
KD-5	3		51	I65	1932		1705/2330t, 97.7x8.2x4.7m, 2d/em, 6000/1800hp, 20.5/8.2kts, 75p, 75m; 1x1-100/50, 1x1-13.2, 6-533TT
			52	I66	1932		
			53	I67	1932		
J-1M	1	54	I5	1932		2243/2921t, 97.5x9.1x4.9m, 2d/em, 6000/2600hp, 18/8kts, 93p, 80m; 1x1-140/40, 6-533TT, 1seaplane (E9W)	
KD-6a	1	55	I68	1934		1785/2440t, 104.7x8.2x4.6m, 2d/em, 9000/1800hp, 23/8.2kts, 60p, 70m; 1x1-100/50, 1x1-13.2, 6-533TT	
SSX	A	2	1 - 2	No1, 2	1934		40/45t, 23.9x1.9x1.9m, 1em, 600hp, 19/24kts, 2p; 2-450TT

ESCORTS

PC	Ch1	2	1	Ch1	1934		280t, 65.3x5.9x1.4m, 2d, 3400hp, 24kts, 45p; 1x2-40/62, 2DCR
			2	Ch2	1934		

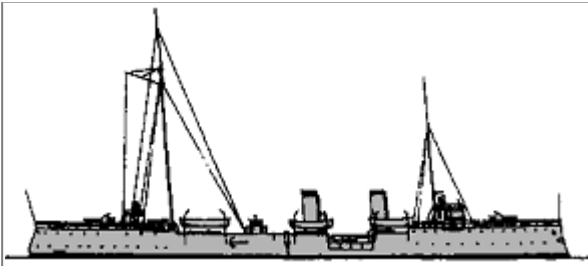
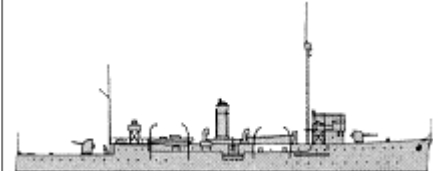
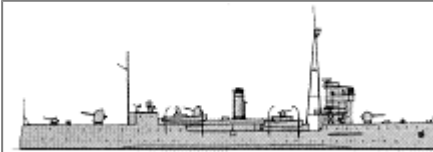
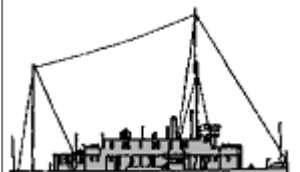
OTHER FIGHTING SHIPS

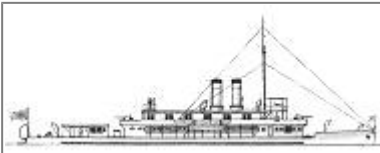
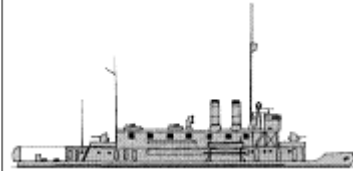
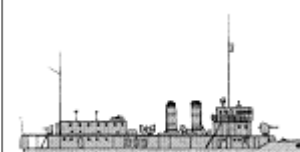
	Chihaya	1	1	Chihaya (TS)	1901		1464t, 87.7x9.6x2.8m, 4b,2vte, 6000hp, 21kts, 125p; 2x1-120/40, 4x1-76/40, 2x1-450TT





PG							
	Saga	1	2	Saga	1912		885t, 69.0x9.0x2.2m, 2b,2vte, 1600hp, 15kts, 98p; 1x1-120/45, 3x1-76/40
	Ataka	1	3	Ataka	1923		1133t, 71.7x9.0x2.3m, 2b,2vte, 1700hp, 16kts, 118p; 2x1-120/45, 2x1-76/40
PR	Sumida	1	1	Sumida	1906		126t, 44.2x7.2x0.6m, 2b,3vte, 550hp, 13kts, 40p; 2x1-47/40
	Fushimi	1	2	Fushimi	1906		180t, 48.7x7.4x0.7m, 2b,3vte, 900hp, 14kts, 45p; 2x1-57/40
	Toba	1	3	Toba	1911		291t, 55.9x8.2x0.8m, 2b,3vte, 1400hp, 15kts, 59p; 2x1-76/23
	Seta	4	4	Seta	1923		400t, 56.1x8.2x1.0m, 2b,2vce, 2100hp, 16kts, 62p; 2x1-76/40
			5	Kataka	1923		
			6	Hira	1923		
			7	Hozu	1923		
Atami	2	8	Atami	1929		249t, 46.3x6.3x0.9m, 2b,2vce, 1300hp, 16.7kts, 77p; 1x1-76/23, 1x1-13.2	
		9	Futami	1930			
Kotaka	1	10	Kotaka	1930		63t, 30.5x4.9x0.6m, 2d, 540hp, 15.5kts	

COASTAL FORCES

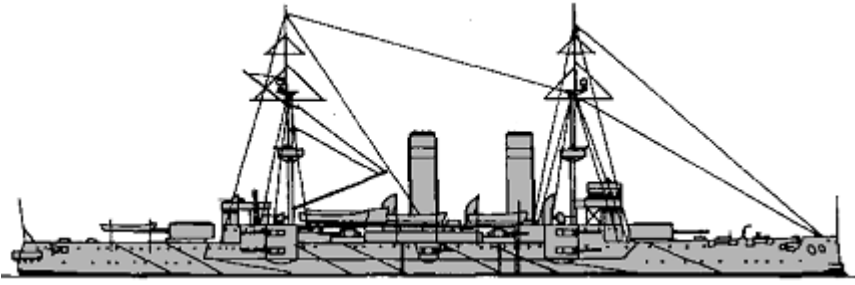
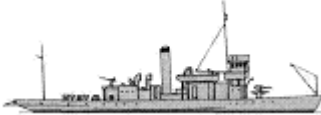
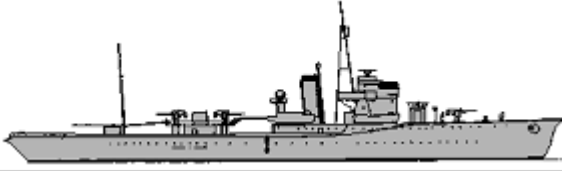
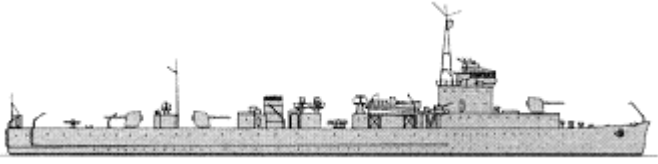
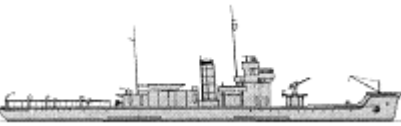
PT	CMB-55	4	1 - 4	No615, 1149 and 2 others	1920		14t, 16.8x3.4x1.0m, 2pe, 1000hp, 40kts, 5p; 2-450TR, 1DCR
----	--------	---	-------	--------------------------	------	---	---

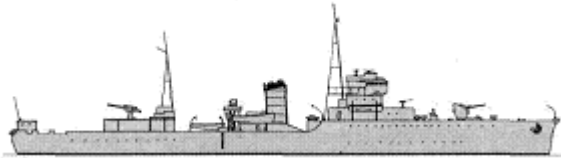
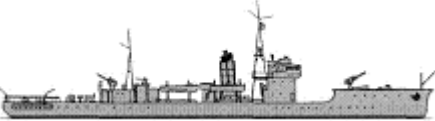
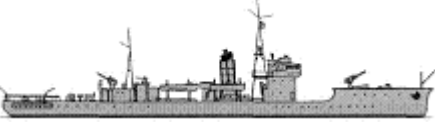
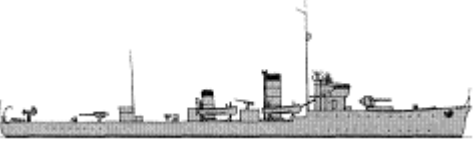
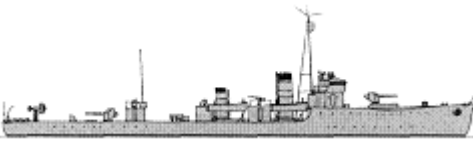
MINE WARFARE

ML	Tokiwa	1	1	Tokiwa	1899		10500t, 134.7x20.5x7.4m, 16b,2vte, 18000hp, 21.5kts, 726p; Harvey: 178belt, 76deck, 152turrets, 356CT; 1x2-203/45, 8x1-152/40, 3x1-76/40, 300m
	Natsushima	12	2	Sokuten	1913		435t, 45.7x7.6x2.3m, 1b,1vte(2), 600hp, 12.8kts, 40p; 2x1-76/40, 120m, MS
			3	Toshima	1915		
			4	Kuroshima	1915		
			5	Ashizaki	1916		
			6	Katoku	1916		
			7	Kurokami	1917		
			8	Katashima	1917		
			9	Ento	1917		
			10	Enoshima	1919		
11			Kurosaki	1921			
12			Ninoshima	1920			
13			Washizaki	1921			
Katsuriki			1	14	Katsuriki		
Shirataka	1	15	Shirataka	1929		1692t, 90.0x11.6x3.1m, 2b,2vte, 2000hp, 16kts, 175p; 3x1-120/45, 100m	
Itsukushima	1	16	Itsukushima	1929		2408t, 107.5x11.8x3.2m, 3d, 3000hp, 17kts, 235p; 3x1-40/50, 2x1-76/40, 300m, 2DCT	
Kamome	2	17	Kamome	1929		557t, 68.8x7.2x2.1m, 2b,2vte, 2500hp, 19kts, 56p; 1x1-76/40, 1x1-13.2, 120m	
		18	Tsubame	1929			

	Yaeyama	1	19	Yaeyama	1932		1384t, 93.5x10.7x2.8m, 2b,2vte, 4800hp, 20kts, 150p; 2x1-120/45, 2x1-13.2, 185m
	Natsushima	2	20	Natsushima	1933		510t, 70.0x7.5x1.9m, 2d, 2300hp, 19kts, 74p; 2x1-76/40, 1x1-13.2, 120m, MS
			21	Nasami	1934		
	Sarushima	1	22	Sarushima	1934		585t, 70.0x7.5x1.9m, 2d, 2100hp, 18kts, 74p; 2x1-76/40, 1x1-13.2, 120m, MS
MS	W1	4	1	W1	1923		702t, 76.3x8.0x2.3m, 3b,2vte, 4000hp, 20kts, 92p; 2x1-120/45, 1x1-76/40, MS
			2	W2	1923		
			3	W3	1923		
			4	W4	1925		
	W5	2	5	W5	1929		717t, 77.0x8.3x2.3m, 3b,2vte, 4000hp, 21kts, 87p; 2x1-120/45, 1x1-76/40, 1x1-13.2, MS
			6	W6	1929		
	Umikaze	2	7	W7	1911		1150t, 98.5x8.5x2.7m, 4b,3t, 11000hp, 24kts, 140p; 1x1-120/40, 4x1-76/40, MS
			8	W8	1911		
	Enoki	2	9	W9	1918		1100t, 85.8x7.7x2.3m, 4b,2gt, 17500hp, 31.5kts, 110p; 2x1-120/40, MS
			10	W10	1918		
	W13	4	11	W13	1933		560t, 74.0x8.2x2.1m, 2b,2vte, 3200hp, 20kts, 98p; 2x1-120/45, 2x1-13.2, MS
			12	W14	1933		
			13	W15	1934		
			14	W16	1934		

NAVAL AVIATION (approximately, maximal number of delivered planes signed)

Deck planes	F: 50 A1N1, 100 A1N2, 106 A2N1/2/3 (delivery till 1936); TB: 204 B2M1/2, 130 B3Y1 (delivery till 1936); DB: 163 D1A1 (delivery till 1937); R: 159 C1M1/2/4
Seaplanes	R: 77 E2N1, 12 E3A1, 85 E4N2, 20 E5Y1, 185 E7K1 (delivery till 1938)

© Ivan Gogin, 2011-14

[home](#)[World navies yesterday](#)[1935](#)

Latvia 01 January 1935

SUBMARINES

SS	Ronis	2	1	Ronis	1927		390/514t, 55.0x4.8x3.6m, 2d/em, 1300/700hp, 14/9kts, 27p, 50m; 1x1-75/35, (2+2x2)-450TT
			2	Spidola	1927		

ESCORTS

PC	Virsaitis	1	1	Virsaitis	1917		539t, 59.3x7.4x2.2m, 2b,2vte, 1850hp, 16kts, 51p; 2x1-88/45, 30m, MS
----	-----------	---	---	-----------	------	---	--

MINE WARFARE SHIPS

MS	Viesturs	2	1	Viesturs	1926		310t, 48.9x6.5x1.5m, 2b,2vte, 750hp, 14kts, 39p; 1x1-75/35, 30m, MS
			2	Imanta	1926		

© Ivan Gogin, 2011-15

[home](#)

[World navies yesterday](#)

[1935](#)

Lithuania 01 January 1935

ESCORTS

PC	Prezidentas Smetona	1	1	Prezidentas Smetona	1917		535t, 59.3x7.3x2.2m, 2b,2vte, 1750hp, 16kts, 70p; 2x1-105/45, 30m, MS
----	---------------------	---	---	---------------------	------	--	---

© Ivan Gogin, 2011-15



[home](#)[World navies yesterday](#)[1935](#)

Manchukuo 01 January 1935

ESCORTS

PC	Hai Feng	2	1	Hai Feng	1933		220t, 43.6x6.1x1.5m, 2d, 800hp, 14kts; 2x1-76/40, 2x1-12.7, 2DCT
			2	Hai Lung	1933		

OTHER FIGHTING SHIPS

PGR	Li Sui	1	1	Li Sui	1904		280t, 50.1x8.0x0.9m, 2b,2vte, 1300hp, 13kts, 50p; 2x1-57/40
	Shun Tien	2	2	Shun Tien	1934		270t, 55.8x8.8x0.9m, 2d, 680hp, 12.5kts, 70p; (1x2+1x1)-120/45, 2x1-70/12mrt, 3x2-13.2, 80m
3			Yang Min	1934			
APGR	-	4	1	Kiang Ping	1897		250t; 1x1-76/40
			2	Kiang Chin	1903		250t; 1x1-76/40
			3	Kiang An	1897		250t; 1x1-76/40
			4	Li Tsy	1897		250t; 1x1-76/40

COASTAL FORCES

YP	Hai Kuang	4	1-4	Hai Kuang, Hai Jui, Hai Jung, Hai Hua	1933	No picture	45t, 25.9x3.9x0.9m, 1d, 240hp, 12kts; 1x1-57/40
YPR	Shun Tsu	1	1	Shun Tsu	1919	No picture	15t, 18.3x3.0x0.7m, 2pe, 100hp, 15kts, 14p; 1x1-37/23
	Ta Tung	2	2,3	Ta Tung, Li Min	1933	No picture	56t, 30.5x4.9x0.8m, 2d, 240hp, 10.5kts, 20p; 1x1-57/40
	On Min	8	4-11	On Min, Hai Min, Hui Min, Pu Min, Wen Min, Yi Min, En Min, Wan Min	1933	No Picture	15t, 18.2x3.4x0.8m, 1d, 80hp, 11kts

© Ivan Gogin, 2011-15

[home](#)

[World navies yesterday](#)

[1935](#)

Mexico 01 January 1935

CAPITAL SHIPS

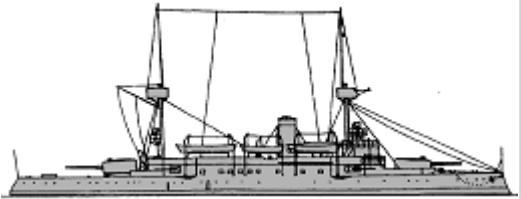
BC	Anahuac	1	1	Anahuac	1900		3162t, 81.5x14.4x4.2m, 8b,2vte, 3400hp, 15kts, 200p; Harvey steel; 350belt, 45deck, 220turrets, 125CT; 2x1-234/45, 4x1-120/50, 6x1-57/40, 2-450TT
----	---------	---	---	---------	------	--	---

CRUISERS

CLP	Progreso	1	1	Progreso	1907		1700t, 70.1x10.3x3.0m, 1vte, 1400hp, 13kts, 140p; 4x1-57/40, troops
-----	----------	---	---	----------	------	--	---

ESCORTS

TL	Salinas	4	1	Salinas	1917	No picture	486t, 40.5x7.1x4.1m, 1b,1vte, 557hp, 7kts, 26p; 1x1-57/40(2,3), 2x1-40/39(2,3), 1x1-25/60(1,4), 1x1-13.2(1,4)
			2	Mazatlan	1917		
			3	Tampico	1917		
			4	Vera Cruz	1917		

OTHER FIGHTING SHIPS

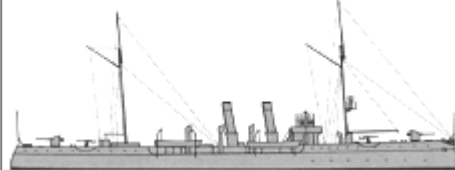
PG	Nicholas Bravo	1	1	Nicholas Bravo	1904		1493t, 73.8x10.4x3.0m, 2vte, 2565hp, 17kts, 116p; 2x1-102/40, 6x1-57/40, 1-356TT
----	----------------	---	---	----------------	------	--	--

	Agua Prieta	1	2	Agua Prieta	1893		1318t, 62.2x9.8x3.7m, 2b,2vte, 1900hp, 15.5kts, 157p; 8x1-102/40, 2x1-57/40
--	-------------	---	---	-------------	------	---	---

COASTAL FORCES

PS	18 de Mayo	2	1, 2	18 de Mayo, Yaqui	1917 - 1918		85t, 33.5x4.5x1.7m, 3pe, 660hp, 18kts, 27p; 1x1-76/23, 1DCT
----	------------	---	------	-------------------	-------------	---	---

© Ivan Gogin, 2011-15

[home](#)[World navies yesterday](#)[1935](#)

NETHERLANDS 01 January 1935

CAPITAL SHIPS

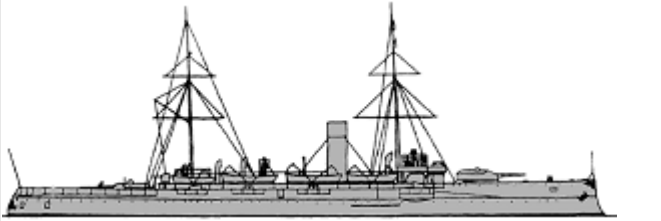
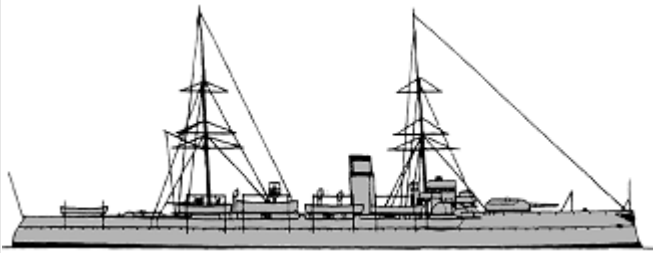
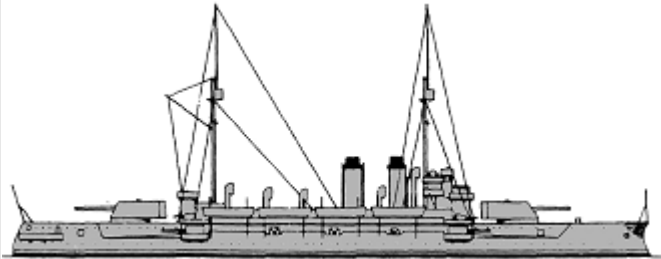

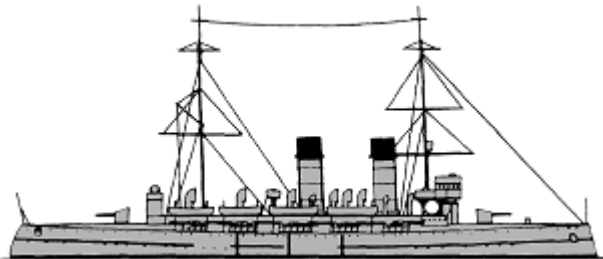
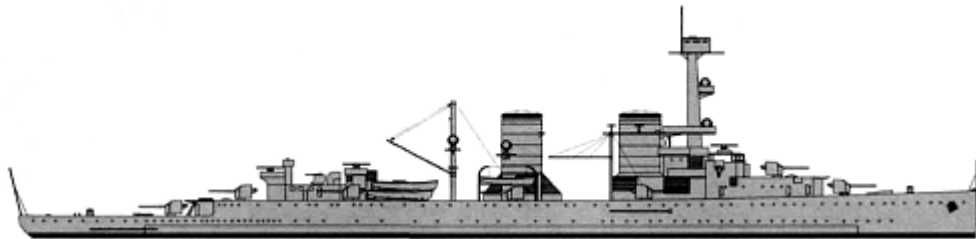

	Koningin Regentes	1	1	Hertog Hendrik	1904		5084t, 96.6x15.2x6.8m, 6b,2vte, 6500hp, 16.5kts, 340p; 152belt, 51deck, 102turrets, 246CT; 1x1-240/40, 4x1-150/40, 4x1-75/55, 3-450TT, 2seaplanes (C.VIIW)
BC	Jacob van Heemskerck	1	2	Jacob van Heemskerck	1908		4920t, 98.0x15.2x5.7m, 8b,2vte, 6400hp, 16.5kts, 340p; 152belt, 51deck, 102turrets, 194CT; 2x1-240/40, 4x1-150/40, 6x1-75/55, 2-450TT
	De Zeven Provinciën	1	3	De Zeven Provinciën	1910		6510t, 103.5x17.1x6.2m, 8b,2vte, 8000hp, 16kts, 448p; 150belt, 50deck, 250turrets, 200CT; 2x1-283/43, 4x1-150/40, 10x1-75/55

CRUISERS

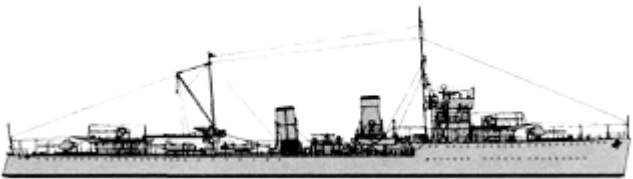

	Holland	1	1	Gelderland	1900		3970t, 94.7x14.8x5.4m, 10b,2vte, 10000hp, 20kts, 371p; Harvey; 57deck, 152shields, 102CT; 8x1-120/40, 4x1-75/55
--	---------	---	---	------------	------	--	---

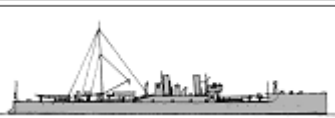









CL						
	Java	2	3	Java Sumatra	1925 1926	

TORPEDO SHIPS

DD	Van Ghent	4	1	Van Ghent	1928		1640t, 98.2x9.5x3.0m, 3b,2gt, 31000hp, 36kts, 129p; 4x1-120/50, 2x1-75/55, 4x1-12.7, 2x3-533TT, 4DCT, 32m, 1seaplane (C.VIIW)
			2	Evertsen	1928		
			3	Kortenaer	1928		
			4	Piet Hein	1928		
DD	Van Galen	4	5	Van Galen	1929		1650t, 98.2x9.5x3.0m, 3b,2gt, 31000hp, 36kts, 120p; 4x1-120/50, 1x1-75/55, 4x1-40/39, 4x1-12.7, 2x3-533TT, 4DCT, 1seaplane (C.VIIW)
			6	Witte de With	1930		
			7	Banckert	1930		
			8	Van Nes	1931		
TB	G13	3	1	G13	1914		230t, 49.5ppx5.3x1.5m, 2b,2vte, 2600hp, 25kts, 27p; 2x1-75/30, 3x1-450TT
			2	G15	1914		
			3	G16	1914		
TB	Z5	3	4	Z6	1917		310t, 58.5ppx6.1x1.7m, 3b,2vte, 5500hp, 27kts, 46p; 2x1-75/30, 2x1-12.7, (1x2+2x1)-450TT
			5	Z7	1916		
			6	Z8	1916		
TB	Z1	1	7	Z3	1920		322t, 62.6x6.2x1.9m, 3b,2t, 5500hp, 27kts, 46p; 2x1-75/30, 2x1-12.7, (1x2+2x1)-450TT

SUBMARINES

O2	2	1	O4	1914		130/150t, 32.1x3.3x2.7m, 1d/em, 350/200hp, 11/8.6kts, 10p, 25m; 2-450TT
		2	O5	1914		
O6	1	3	O6	1916		189/229t, 35.7x4.1x3.1m, 1d/em, 375/185hp, 12/8.5kts, 15p, 40m; 3-450TT



SS	O7	1	4	O7	1916		176/206t, 34.7x3.9x2.9m, 1d/em, 350/185hp, 11.5/8.5kts, 15p, 40m; 3-450TT
	O8	1	5	O8	1915		364/434t, 45.8x4.7x3.8m, 2d/em, 480/620hp, 13/11kts, 22p, 50m; 1x1-37/45, 4-450TT
	K III	1	6	K IV	1921		583/721t, 64.4x5.6x3.6m, 2d/em, 1200/630hp, 15/8.5kts, 29p, 40m; 1x1-75/55, 1x1-12.7, (4+1x2)-450TT
	K V	3	7	K V	1920		569/649t, 57.3x5.6x3.8m, 2d/em, 1200/400hp, 13.5/8kts, 31p, 40m; 1x1-75/55, 1x1-12.7, (4+1x2)-450TT
			8	K VI	1921		
			9	K VII	1922		
	K II	1	10	K II	1922		569/649t, 57.3x5.3x3.8m, 2d/em, 1800/500hp, 15.5/8.5kts, 29p, 40m; 1x1-75/55, 1x1-12.7, (4+1x2)-450TT
	K VIII	3	11	K VIII	1922		583/810t, 64.4x5.6x3.6m, 2d/em, 1800(11)-1550(12,13)/400hp, 16(11)-15(12,13)/8kts, 31p, 50m; 1x1-88/45, 1x1-12.7, 4-450TT
			12	K IX	1923		
			13	K X	1923		
	K XI	3	14	K XI	1925		688/828t, 66.7x6.2x3.8m, 2d/em, 2400/654hp, 17/8kts, 31p, 60m; 1x1-88/45, 1x1-12.7, 2-533TT, 4-450TT
			15	K XII	1925		
			16	K XIII	1926		
	O9	3	17	O9	1926		526/656t, 54.7x5.7x3.5m, 2d/em, 900/500hp, 12/8kts, 29p, 60m; 1x1-88/45, 1x1-12.7, 2-533TT, 3-450TT
			18	O10	1926		
19			O11	1926			
O12	4	20	O12	1931		610/754t, 60.4x6.8x3.6m, 2d/em, 1800/620hp, 16/8kts, 31p, 60m; 2x1-40/40, 1x1-12.7, 5-533TT	
		21	O13	1931			
		22	O14	1932			
		23	O15	1932			
K XIV	5	24	K XIV	1933		865/1045t, 73.6x6.5x3.9m, 2d/em, 3200/960hp, 17/9kts, 38p, 80m; 1x1-88/45, 2x1-40/40, (6+1x2)-533TT	
		25	K XV	1933			
		26	K XVI	1934			
		27	K XVII	1933			
		28	K XVIII	1934			

ESCORTS

Albatros	1	1	Albatros	1912	No picture	892t, 50.0ppx9.4x3.3m, 1vte, 1140hp, 12kts, 47p; 2x1-37/45
Orion	1	2	Orion	1912	No picture	1062t, 55.9ppx9.0x3.7m, 1vte, 1380hp, 14kts, 71p; 2x1-75/55
Aldebaran	1	3	Aldebaran	1913	No picture	892t, 53.3ppx8.2x3.5m, 1vte, 800hp, 12kts, 45p; 2x1-37/45
Bellatrix	3	4	Bellatrix	1914	No picture	773t, 53.3ppx9.0x3.0m, 1vte, 800hp, 12kts, 45p; 1x1-75/55(4), 2x1-37/45(5,6)
		5	Canopus	1915		
		6	Deneb	1915		
Eridanus	1	7	Eridanus	1918	No picture	996t, 56.5ppx9.0x3.2m, 1vte, 800hp, 12kts, 44p; 1x1-75/55
Gemma	1	8	Gemma	1918	No picture	845t, 53.3ppx9.0x3.2m, 1vte, 800hp, 12kts, 44p; 1x1-75/55

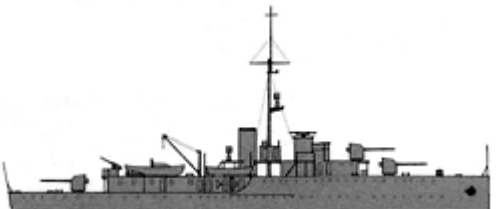
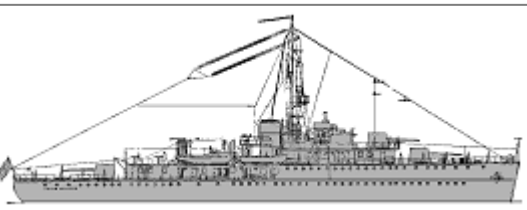

PC	Sirius	2	9	Sirius	1922	No picture	1015t, 55.6ppx9.5x3.3m, 1vte, 900hp, 12.5kts, 50p; 1x1-75/55
			10	Wega	1922		
	Fomalhaut	1	11	Fomalhaut	1923	No picture	1001t, 56.9ppx9.5x3.4m, 1vte, 855hp, 12.5kts, 55p; 2x1-37/45
	Merel	3	12	Merel	1928	No picture	592(12)-624(13,14)t, 46.4(12)-47.8(13,14)ppx8.4x2.8m, 2b,1vte, 525hp, 12kts, 40p; 1x1-75/55
			13	Reiger	1931		
			14	Fazant	1931		
Arend	2	15	Arend	1929	No picture	1011t, 71.9x9.0x2.8m, 2b,2vte, 3350hp, 18kts, 61p; 2x1-75/55, 1seaplane (C.VIIW)	
		16	Valk	1929			
Z5	1	17	Z5	1917		310t, 58.5ppx6.1x1.7m, 2b,2vte, 3000hp, 22kts, 34p; 2x1-75/30, 2x1-12.7	

OTHER FIGHTING SHIPS

PG	Brinio	3	1	Brinio	1914		634(1)-573(2)-581(3)t, 52.7x8.5x2.8m, 2d, 1500hp, 14kts, 52p; 55belt, 17deck, 50shields, 50CT; 4x1-105/50, 2x1-12.7
			2	Friso	1915		
			3	Gruno	1915		
	Flores	2	4	Flores	1926		1793t, 76.4x11.5x3.6m, 4b,2vte, 2000hp, 15kts, 132p; 50slopes, 25deck, 80shields, 50CT; 3x1-150/50, 1x1-75/55, 2x2-12.7, 1seaplane (C.VIIW)
5	Soemba	1926					
Johan Maurits van Nassau	1	6	Johan Maurits van Nassau	1933		1795t, 83.6x11.6x3.7m, 4b,2vte, 2100hp, 15kts, 124p; 50slopes, 25deck, 40shields, 25CT; 3x1-150/50, 1x2-40/56, 2x2-12.7, 1seaplane (C.VIIW)	
PR	Wodan	4	1	K2 Christiaan Cornelis	1905	No picture	47t, 30.0x3.6x1.7m, 1b,1vte, 560hp, 18.7kts, 12p; 1x1-37/23
			2	Braga	1879		280t, 27.8x8.2x2.3m, 2b,1vce, 171hp, 8.3kts, 34p; 1x1-120/40(3,5), 1x1-75/55(4), 2x1-37/23, 1x5-37/20
			3	Freyr	1877		
			4	Tyr	1878		
			5	Hefring (TS)	1880		

MINE WARFARE SHIPS

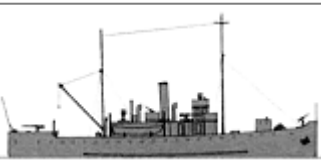
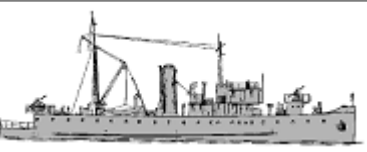
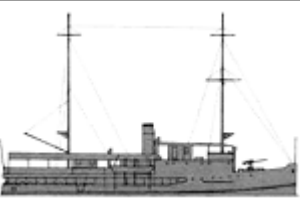
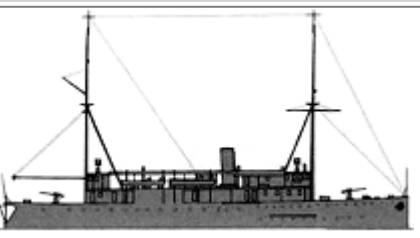
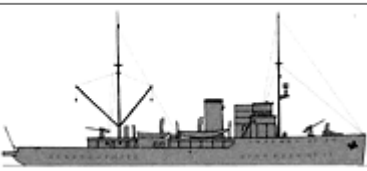
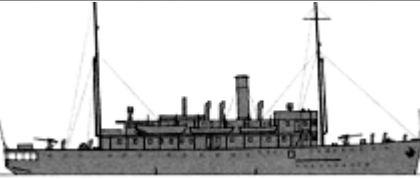
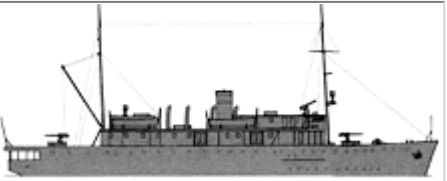
Hydra	1	1	Havik	1874		218t, 25.9x8.2x2.3m, 2b,1vce, 146hp, 8kts, 34p; 2x1-37/23, 1x5-37/20, ~20m
			Balder	1879		
			Thor	1877		

ML	Wodan	5	4	Vidar	1879		280t, 27.8x8.2x2.3m, 2b,1vce, 171hp, 8.3kts, 34p; 1x1-150/40(6), 2x1-37/23, 1x5-37/20, ~20m
			5	Hadda	1880		
			6	Bulgia	1884		
	Hydra	2	7	Hydra	1912		670t, 49.7x9.0x2.8m, 2b,2vte, 900hp, 11kts, 59p; 3x1-75/55, 2x1-12.7, 70m
			8	Medusa	1911		
	Van Meerlant	2	9	Van Meerlant	1922		748t, 54.8ppx8.7x3.2m, 2b,2vte, 1000hp, 13kts, 60p; 3x1-75/55, 2x1-12.7, 60m
			10	Douwe Aukes	1922		
		1	11	Pro Patria	1923		612t, 47.0ppx8.6x2.3m, 2b,1vte, 650hp, 10kts, 61p; 1x1-75/40, 2x1-12.7, 60m
		1	12	Krakatau	1924		1160t, 65.0ppx10.0x3.2m, 2b,1vte, 2500hp, 15.5kts, 105p; 2x1-75/40, 4x1-12.7, 150m
		1	13	Nautilus	1930		951t, 58.7x9.5x3.5m, 3b,2vte, 1350hp, 15kts, 57p; 2x1-75/55, 1x1-37/45, 2x1-12.7, 60m
	1	14	Rigel	1931		1631t, 74.0x11.0x3.1m, 2b,2vte, 1400hp, 12.7kts, 67p; 2x1-75/40, 2x1-12.7, 150m	
	Prins van Oranje	15	Prins van Oranje	1932		1600t, 70.0x11.0x3.3m, 2b,2vte, 1750hp, 15kts, 121p; 2x1-75/55, 2x1-40/39, 2x1-12.7, 150m	
		16	Gouden Leeuw	1932			
MS	Nr.1	4	1	M1	1918	No picture	238(1)-205(2)-230(3,4)t, 30.5(1)-29.7(2)-29.8(3,4)x 7.0(1)-6.7(2)-6.4(3,4)x 2.8(1)-3.1(2)-2.5(3,4)m, 1b,1vte, 500(1,2)-450(3,4)hp, 9.5(1)-10(2-4)kts, 16p; 1x1-12.7, MS
			2	M2	1918		
			3	M3	1918		
			4	M4	1918		
	A	4	5	A	1930		179t, 42.8x6.0x1.5m, 1b,1vte, 700hp, 14.5kts, 38p; 2x1-12.7, MS
			6	B	1930		

				
7	C	1930		
8	D	1930		

NAVAL AVIATION *(approximately, maximal number of delivered planes signed)*

Seaplanes	R: 30 C.VIIW
-----------	--------------

© Ivan Gogin, 2011-14

[home](#)

[World navies yesterday](#)

[1935](#)

NEW ZEALAND 01 January 1935

CRUISERS

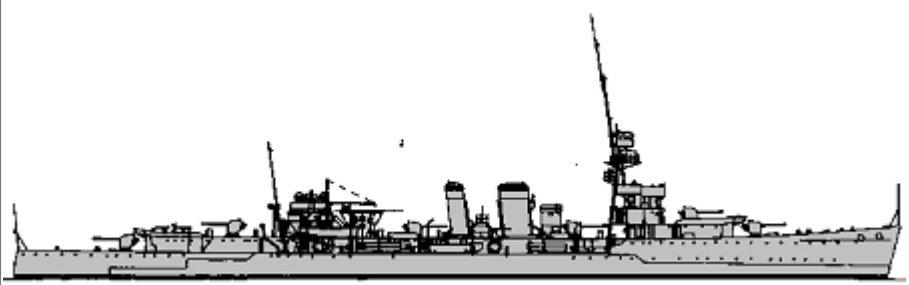
		1	Dunedin	1919		5870t, 143.6x13.9x5.0m, 6b, 2gt, 40000hp, 29kts, 450p; 76belt, 25shields, 25deck, 76CT; 6x1-152/45, 3x1-102/45, 2x1-40/39, 4x3-533TT
CL	Delhi	2	Diomedede	1922		

© Ivan Gogin, 2010-15



[home](#)[World navies yesterday](#)[1935](#)

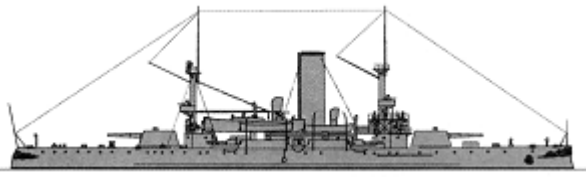
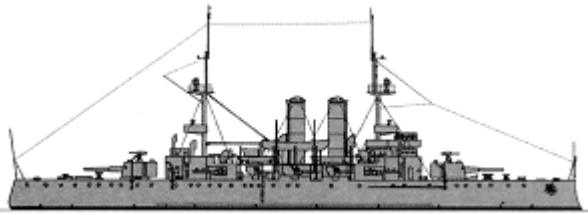

Norway 01 January 1935

CAPITAL SHIPS

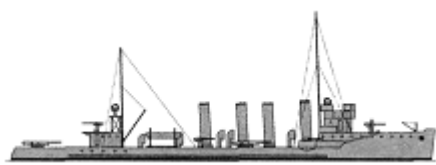

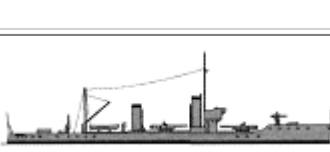
BC	Harald Haarfagre	1	Harald Haarfagre	1898		3858t, 92.7x14.8x5.4m, 3b,2vte, 4000hp, 16.9kts, 245p; h: 178belt, 51deck, 203turrets, 152CT; 2x1-209/44, 6x1-120/44, 6x1-76/40, 2x1-47/46, 6x1-37/45, 2-450TT
		2	Tordenskjold	1898		
BC	Norge	3	Norge	1901		4166t, 94.6x15.4x5.4m, 6b,2vte, 4500hp, 16.5kts, 266p; 152belt, 51deck, 203turrets, 152CT; 2x1-209/44, 6x1-149/46, 8x1-76/40, 6x1-47/46, 2-450TT
		4	Eidsvold	1901		

TORPEDO SHIPS





DD	Draug	3	1	Draug	1909		578(1,2)-597(3)t, 69.2x7.3x2.9m, 4b, 2vte(1,2)-2t(3), 7500(1,2)-8000(3)hp, 26.5(1)-27(2)-27.4(3)kts, 76p; 6x1-76/40, 3x1-450TT
			2	Troll	1912		
			3	Garm	1914		
TB	Storm	2	1	Storm	1898		107t, 39.9x4.8x2.2m, 2b,1vte, 1100hp, 21kts, 23p; 2x1-37/45, 2x1-450TT
			2	Brand	1898		
	Laks	4	3	Laks	1900		107t, 38.5x4.8x2.2m, 2b,1vte, 1150hp, 21kts, 23p; 2x1-37/45, 2x1-450TT
			4	Sild	1900		
			5	Sæl	1901		
			6	Skrei	1901		
	Trygg	3	7	Trygg	1920		256t, 53.0x5.5x2.0m, 2b,2vte, 3500hp, 25(10,11)-24(12)kts, 33p; 2x1-76/28, 2x2-450TT, 10m
			8	Snøgg	1921		
			9	Stegg	1923		
	Ørn	2	10,	Ørn, Ravn	1905		73t, 34.5x4.4x1.6m, 2b,1vte, 850hp, 23kts, 16p; 2x1-37/45, (1+1x1)-450TT

			11				
Grib	3	12-14	Grib, Jo, Lom	1906		74t, 36.2x4.5x1.9m, 2b,1vte, 1000hp, 23kts, 16p; 2x1-37/45, (1+1x1)-450TT	
Teist	3	15	Teist	1908		103(27,28)-108(29)t, 41.1x4.7x2.3(27,28)-2.4(29)m, 2b,1vte, 1700hp, 25kts, 21p; 1x1-76/28(29), 2x1-47/46(27,28), (1+2x1)-450TT(27,28), (1+1x1)-450TT(29)	
		16	Skarv	1908			
		17	Kjell	1913			



SUBMARINES

SS	A2	3	1	A2	1914		268/342t, 46.5x4.8x2.7m, 2d/em, 700/380hp, 14.5/9kts, 17p, 50m; 3-450TT
			2	A3	1914		
			3	A4	1914		
	B1	6	4	B1	1923		420/545t, 51.0x5.3x3.5m, 2d/em, 900/700hp, 14.5/10.5kts, 23p, 60m; 1x1-76/28, 4-450TT
			5	B2	1924		
			6	B3	1926		
			7	B4	1927		
			8	B5	1929		
			9	B6	1930		

ESCORTS

PC	Lyn	2	1, 2	Lyn, Blink	1896		64t, 34.5x3.8x1.8m, 2b,1vte, 650hp, 19kts, 21p; 2x1-37/45
	Djerv	3	3-5	Djerv, Kvikk, Dristig	1897-1898		66t, 34.5x3.8x1.7m, 2b,1vte, 650hp, 19kts, 21p; 2x1-37/45, MS(3,4)
	Hvass	2	6, 7	Hvass, Kjæk	1901		74t, 34.1x4.4x1.6m, 2b,2vte, 650hp, 19kts, 16p; 2x1-37/45, MS
	Hauk	2	8, 9	Hauk, Falk	1904		73t, 34.9x4.4x1.6m, 2b,2vte, 750hp, 20kts, 16p; 2x1-37/45, MS
FPV	Fridtjof Nansen	1	1	Fridtjof Nansen	1931		1545t, 73.0x10.6x5.0m, 2b,2vte, 2000hp, 15kts, 67p; 2x1-102/40, 2x1-47/46, 1seaplane
AFPV	-	2	1	Michael Sars	1900		226t
			2	Heimdal	1892		640t; 4x1-76/40

MINE WARFARE SHIPS

Vale	2	1	Vale	1874		250t, 27.3x7.9x2.2m, 2b,2vte, 200hp, 8kts, 38p; 1x1-120/44, 1x1-37/45, 2x5-37/21, 50m
		2	Uller	1877		
Brage	2	3	Brage	1879		270t, 28.9x7.9x2.2m, 2b,2vte, 220hp, 8.5kts, 38p; 1x1-149/46, 1x1-47/46, 2x5-37/21, 1-356TT(4), 50m
		4	Nor	1879		

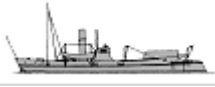
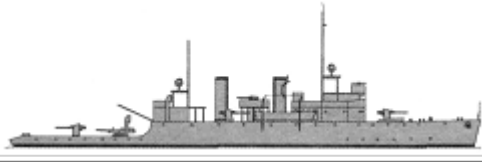
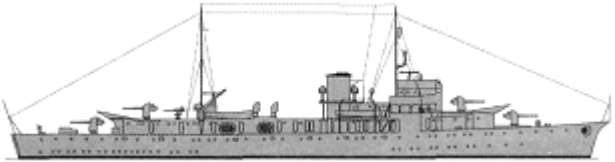
ML	Vidar	1	5	Vidar	1882		270t, 28.9x7.9x2.2m, 2b,2vte, 330hp, 9.5kts, 38p; 1x1-149/46, 1x1-47/46, 2x5-37/21, 50m
	Gor	2	6	Gor	1885		290(6)-278(7)t, 31.3xx2.2m, 2b,2vte, 420hp, 10.5kts; 1x1-120/44, 1x1-76/28(6), 1x1-47/50(7), 2x5-37/21, 1-356TT, 55m
			7	Tyr	1887		
	Frøya	1	8	Frøya	1917		755t, 75.6x8.2x2.8m, 2b,2vte, 7000hp, 21.8kts, 78p; 4x1-102/40, 1x2-450TT, 180m
	Glommen	2	9	Glommen	1917	No picture	380t, 42.0x8.5x2.1m, 1b,1vte, 170hp, 9.8kts, 35p; 2x1-76/28, 120m
			10	Laugen	1918		
Olaf Tryggvason	1	11	Olaf Tryggvason	1934		1860t, 97.3x11.5x3.6m, 3b,2gt/2dg,2em(2), 6000/1400hp, 21kts, 191p; 4x1-120/44, 1x1-76/51, 2x1-40/56, 2x1-12.7, 2x2-450TT, 280m	

[home](#)[World navies yesterday](#)[1935](#)

Paraguay 01 January 1935

ESCORTS

APC	-	2	1	Capitán Cabral	1907		206t; 1x1-76/40
			2	Tacuari	1910		150t; 2x1-76/50, 2x1-76/40

OTHER FIGHTING SHIPS

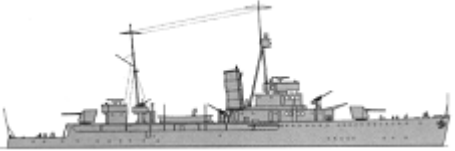
PGR	Paraguay	2	1	Paraguay	1931		835t, 71.2x10.7x2.9m, 2b,2gt, 3800hp, 17kts, 86p; 13belt, 8deck, 10turrets, 19CT; 2x2-120/50, 3x1-76/40, 2x1-40/39, 6m
			2	Humaitá	1931		

© Ivan Gogin, 2011-15

[home](#)[World navies yesterday](#)[1935](#)

Persia 01 January 1935

ESCORTS

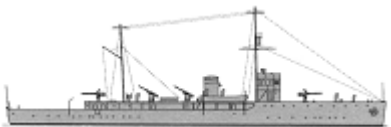
SL	Babr	2	1	Babr	1932		1100t, 62.4ppx9.0x3.0m, 2d, 1900hp, 15kts, 85p; 2x1-102/35, 2x1-76/40, 80m
			2	Palang	1932		
PC	Shahrokh	4	1	Shahrokh	1932	No picture	360t, 51.8ppx6.7x1.8m, 2d, 900hp, 15.5kts; 2x1-76/40, 2x1-37/32
			2	Shahbaz	1932		
			3	Karkass	1932		
			4	Simurgh	1932		

OTHER FIGHTING SHIPS

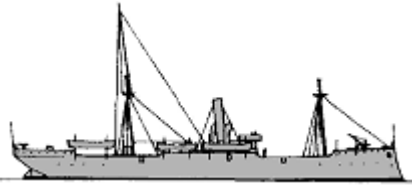
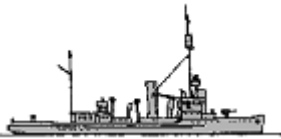
PG	Persepolis	1	1	Persepolis	1885		1200t, 63.1x10.0x5.9m, 1vte, 450hp, 10kts; 1x1-102/40, 2x1-87/25, 2x1-37/32
	Muzaffer	1	2	Muzaffer	1899	No picture	379t, 41.1x7.9x4.0m
	Fathiya	1	3	Pahlavi	1919		193t, 43.0x6.0x1.4m, 1b,2vte, 600hp, 14kts, 35p; 1x1-76/40

COASTAL FORCES

YP	Azerbaijan	3	1-3	Azerbaijan, Gilani, Mazandaran	1933	No picture	32t, 20.9x3.8x1.1m, 2d, 300hp, 14kts, 15p; 1x1-47/44
----	------------	---	-----	--------------------------------	------	------------	--

© Ivan Gogin, 2011-15

[home](#)

[World navies yesterday](#)

[1935](#)

Peru 01 January 1935

CRUISERS

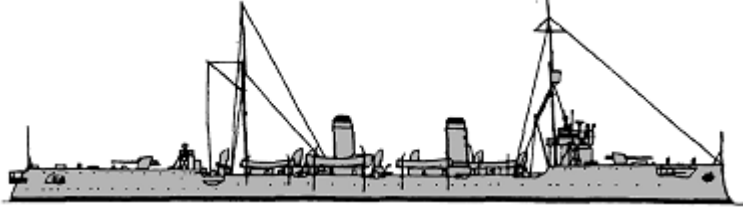
CL	Almirante Grau	1	Almirante Grau	1907		4877t, 115.8x12.3x4.3m, 10b,2vte, 14000hp, 24kts, 320p; 38belt, 38deck, 76shields, 76CT; 2x1-152/50, 6x1-76/40, 6x1-57/40, 2x1-37/23, 2-450TT
		2	Coronel Bolgnesi	1907		

TORPEDO SHIPS

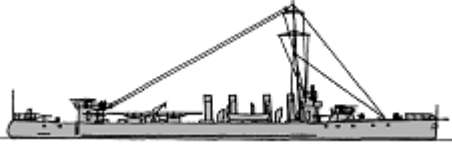
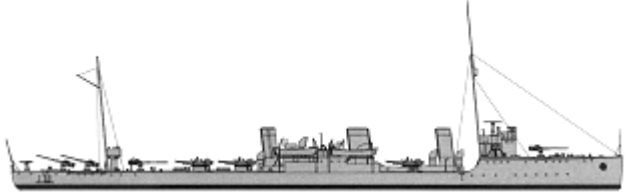
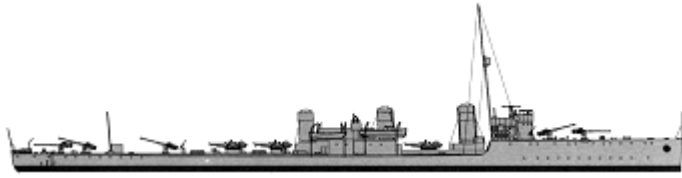
DD	Teniente Rodríguez	1	1	Teniente Rodríguez	1911		520t, 64.6ppx6.5x3.1m, 4b,3t, 8600hp, 28kts, 79p; 6x1-65/50, (1+2x1)-450TT
	Almirante Villar	1	2	Almirante Villar	1917		1620t, 98.0x9.3x3.9m, 4b,2t, 31500hp, 34kts, 142p; 4x1-102/60, 1x1-40/39, 3x3-450TT, 80m
	Almirante Guise	1	3	Almirante Guise	1917		2200t, 107.0x9.5x4.1m, 5b,2t, 32700hp, 35kts, 142p; 5x1-102/60, 1x1-76/30, 3x3-450TT, 80m

SUBMARINES

SS	R1	4	1	R1	1926	576/755t, 56.8x5.3x4.6m, 2d/em, 800/1000hp, 14.5/9.5kts, 30p, 60m; 1x1-76/50, 4-533TT
			2	R2	1926	

3	R3	1928
4	R4	1928

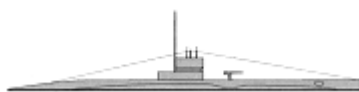

OTHER FIGHTING SHIPS



PGR	Iquitos	1	1	Iquitos	1875	No picture	50t, 23.4x3.7x1.2m, 7.5kts; 1x1-47/40
	América	1	2	América	1904	No picture	240t, 40.5x5.9x1.4m, 2b,2vte, 350hp, 14kts, 26p; 4x1-47/40
	Napo	1	3	Napo	1920	No picture	98t, 30.9x5.5x0.9m, 1b,1vte, 250hp, 12kts, 22p; 4x1-47/40, 2x1-37/23

© Ivan Gogin, 2012-15

[home](#)[World navies yesterday](#)[1935](#)

POLAND 01 January 1935

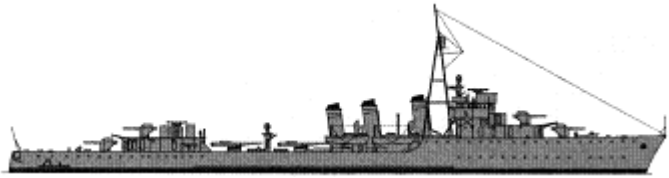
TORPEDO SHIPS



DD	Wicher	2	1	Burza	1932		1920t, 107.2x10.2x3.3m, 3b,2gt, 33000hp, 33kts, 155p; 4x1-130/40, 2x1-40/39, 2x2-13.2, 2x3-550TT, 60m, 2DCT, 2DCR
			2	Wicher	1930		
TB	Ślązak	4	1	Ślązak	1917		381(1,2,4)-392(3)t, 61.1(1,2)-60.0(3)-60.4(4) x6.4x2.2(1,2)-2.3(3)-2.1(4)m, 2b,2t, 6000(1-3)-5700(4)hp, 28(1-3)-26(4)kts, 50(1-3)-55(4)p; 2x1-75/34, 2x1-450TT
			2	Krakowiak	1918		
			3	Kujawiak	1917		
			4	Góral	1917		
	Mazur	1	5	Mazur (TS)	1915		421t, 62.6x6.2x2.5m, 4b,2t, 5500hp, 28kts, 60p; 4x1-75/34

SUBMARINES

SS	Wilk	3	1	Ryś	1931		980/1248t, 78.5x5.9x4.2m, 2d/em, 1800/1200hp, 14.5/9.5kts, 54p, 80m; 1x1-100/40, 1x1-40/39, (4+1x2)-550TT, 38m
			2	Wilk	1931		
			3	Żbik	1932		

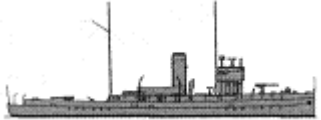
OTHER FIGHTING SHIPS

PG	Generał Haller	2	1	Generał Haller	1921		441t, 50.1x6.8x2.3m, 2b,2vte, 1150hp, 15kts, 49p; 2x1-75/34, 2x1-47/43
			2	komendant Piłsudski	1921		
	Warszawa	4	1	Horodyszcze	1920		126t, 34.7x5.1x0.8m, 3d, 180hp, 10kts, 49p; 6belt, 10deck, 10turrets; 1x1-100/19, 1x2-75/36
			2	Pińsk	1920		
			3	Toruń	1920		

RMON							
		4	Warszawa	1920			
	Kraków	2	5, 6	Kraków, Wilno	1926		90t, 35.0x6.1x0.4m, 2d, 140hp, 7.3kts, 29p; 6belt, 5deck, 8turrets, 8CT; (1x2+1x1)-100/25

COASTAL FORCES

PGRA	Zuchwała	2	1, 2	Zuchwała, Zawzięta	1933		35t, 18.1x4.6x0.6m, 1d, 120hp, 5.6kts, 17p; 6belt, 6deck, 10turret, 6CT; 1x1-100/19, 1x1-37/21
------	----------	---	------	--------------------	------	--	--

MINE WARFARE SHIPS

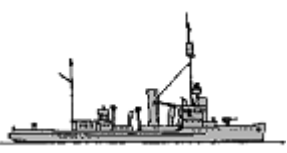
MS	Czajka	3	1	Czajka	1918		193t, 43.0x6.0x1.4m, 1b,2vte, 600hp, 14kts, 35p; 1x1-47/43, 20m, MS
			2	Jaskółka	1918		
			3	Rybitwa	1918		
MSB	T1	6	1-6	T1-6	1930 - 1934	No picture	1x1-37/21, 4m, MS

BOARD GUARD



YP	Batory	1	1	Batory	1932	No picture	28t, 21.2x3.6x1.1m, 3pe, 1100/175hp, 24.3kts, 10p
----	--------	---	---	--------	------	------------	---

© Ivan Gogin, 2011-15

[home](#)[World navies yesterday](#)[1935](#)

PORTUGAL 01 January 1935

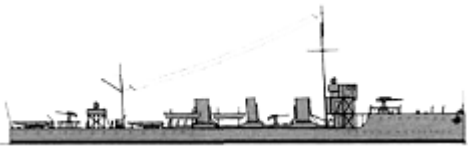
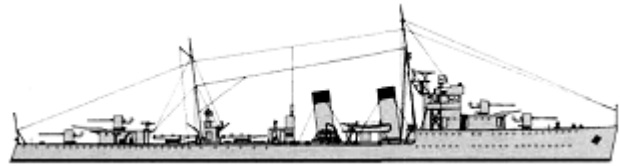
TORPEDO SHIPS



DD	Guadiana	1	1	Tâmega	1923		660t, 73.2x7.2x2.3m, 3b,2t, 11000hp, 27kts, 80p; 1x1-100/41, 2x1-76/40, 2x2-450TT
	Vouga	2	2	Lima	1933		1563t, 98.5x9.5x3.4m, 3b,2gt, 33000hp, 36kts, 127p; 4x1-120/50, 3x1-40/39, 2x4-533TT, 20m 2DCR
3			Vouga	1933			
TB	82F	3	1	Ave	1916		330t, 58.8x5.8x1.5m, 2b,2t, 5000hp, 28kts, 38p; 1x1-66/30, 1x1-57/40, 2x2-450TT
			2	Sado	1916		
			3	Mondego	1916		

SUBMARINES

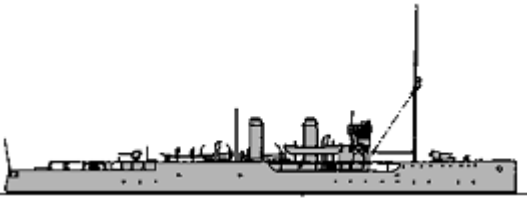

SS	Foca	2	1	Foca	1917		262/382t, 45.6x4.2x3.1m, 2d/em, 550/400hp, 14.2/8.2kts, 21p, 40m; 2-450TT
			2	Hidra	1917		

ESCORTS

	República	1	1	República	1915		1350t, 81.7x10.2x3.4m, 2b,1vte, 2000hp, 16kts, 137p; 2x1-102/40, 2x1-76/40, 4x1-47/40
SL	Carvalho Araujo	1	2	Carvalho Araujo	1915		1275t, 80.0x10.1x3.4m, 2b,1vte, 1800hp, 16.5kts, 137p; 2x1-102/40, 2x1-76/40, 4x1-47/40, 2DCT

							
	Gonçalo Velho	2	3	Gonçalo Velho	1933		1414t, 81.7x10.8x3.4m, 2b,2gt, 2000hp, 16.5kts, 142p; 3x1-120/50, 4x1-40/39, 2DCR
			4	Gonçaves Zarco	1933		
PC	Dili	1	1	Dili	1910s	No picture	495t, 42.7ppx7.6x3.1m, 1vce, 500hp, 11kts, 72p
	Lince	1	2	Lince	1911	No picture	77t, 27.0ppx4.3x1.8m, 2sd, 300hp, 12kts, 20p
	Torres Garcia	1	3	Torres Garcia	1928	No picture	250t, 28.0xxm, 1b,1vte,
FPV	Faro	2	1	Faro	1928		300t, 39.8x6.7x3.2m, 1b,1vte, 650hp, 13kts, 52p; 2x1-47/40
			2	Lagos	1930		

OTHER FIGHTING SHIPS

PG	Limpopo	1	1	Limpopo	1890	No picture	288t, 37.8x6.4x2.0m, 1b,1vc, 520hp, 11.3kts, 54p; 3x1-57/40
	Beira	5	2	Beira	1910		492t, 45.0x8.3x2.1m, 2b,2vte, 700hp, 13kts, 51p; 1x1-87/17(2,5), 2x1-76/50(3), 2x1-76/40(6), 1x1-65/50(2), 2x1-47/40(2,3), 4x1-47/40(4,5)
			3	Ibo	1911		
			4	Mandovi	1917		
			5	Bengo	1917		
			6	Quanza	1917		
	Zaire	3	7	Zaire	1925		492t, 45.0x8.3x2.1m, 2b,2vte, 700hp, 13kts, 67p; 2x1-76/40, 2x1-47/40
			8	Damao	1927		
			9	Diu	1929		
PR	Rio Minho	1	1	Rio Minho	1904	No picture	38t, 24.6x4.0x0.6m, 1b,vte(sw), 64hp, 7.5kts, 8p; 1x1-37/20
	Macau	1	2	Macau	1910		133t, 36.5x6.0x0.7m, 1b,1vte, 250hp, 11.8kts, 24p; 2x1-57/40
	Téte	1	3	Téte	1920	No picture	130t, 23.4x6.1x0.7m, 1b,1vt2(sw), 70hp, 8kts, 20p; 2x1-47/40





MINE WARFARE SHIPS

ML	Vulcano	1	1	Vulcano	1910		151t, 33.5x5.9x1.3m, 1b,2vte, 412hp, 12kts, 24p; 50m
----	---------	---	---	---------	------	--	--

[home](#)[World navies yesterday](#)[1935](#)

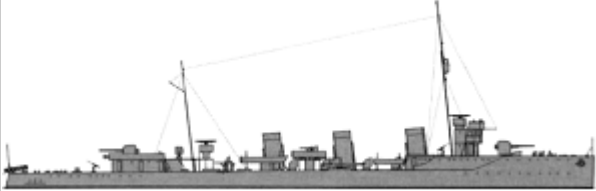
Romania 01 January 1935



TORPEDO SHIPS

DD	Mărăști	1	Mărăști	1917		1723t, 94.7x9.5x3.5m, 5b,2t, 45000hp, 34kts, 139p; (2x2+1x1)-120/45, 2x1-76/40, 2x2-450TT, 50m
		2	Mărășești	1918		
	Regele Ferdinand	3	Regele Ferdinand	1930		
		4	Regina Maria	1930		
TB	Viforul	1	Sborul	1914		320t, 58.2x5.7x1.5m, 2b,2t, 5000hp, 28kts, 41p; 2x1-66/30, 2x2-450TT
	Naluca	2	Naluca	1916		330t, 58.8x5.8x1.5m, 2b,2t, 5000hp, 28kts, 41p; 2x1-66/30, 2x2-450TT
		3	Smeul	1916		
TBR	Căpitan Nicolae Lascăr Bogdan	7	Major Ene Constantin, Căpitan Nicolae Lascăr Bogdan, Căpitan Romani Michail, Major Giurascu Dimitrie, Major Sontu Gheorge, Major Grigore Ioan, Locotenent Calinescu Dimitrie	1906 - 1907		51t, 30.4x4.0x0.8m, 2b,2vce, 550hp, 18kts, 20p; 1x1-47/44, 2spar torpedoes

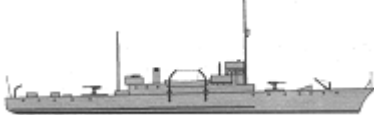
ESCORTS

FS	Căpitan Dumitrescu	1	Căpitan Dumitrescu	1917		443t, 60.2x7.0x2.6m, 2d, 900hp, 14.5kts, 50p; 2x1-100/45, 2DCT
		2	Locotenent-Comandor Stih Eugen	1917		
		3	Locotenent Lepri Remus	1918		
		4	Sublocotenent Ghiculescu	1918		

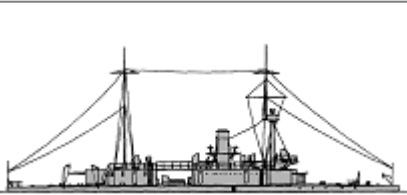

OTHER FIGHTING SHIPS

MONR	Ion C. Brătianu	4	1	Ion C. Brătianu	1907		750t, 62.0-63.5x10.5x1.8m, 2b,2vte, 1800hp, 13kts, 110p; 70belt, 70deck, 75turrets, 75CT; 3x1-120/35, 2x1-120/10, 4x1-47/44
			2	Lascar Catargiu	1907		
			3	Alexandru Lachovari	1908		
			4	Mihail Kogălniceanu	1907		
MONR	Ardeal	1	5	Ardeal	1905		650t, 60.3x9.5x1.6m, 2b,2vte, 1400hp, 13kts, 89p; 40belt, 25deck, 75turrets, 40CT; 2x1-120/50, 2x1-90/45
			6	Bucovina	1915		
			7	Basarabia	1915		
FBR	MR491	6	1	MR491	1916		255t, 54.7x7.1x1.2m, 2sd, 100hp, 5.5kts; 1x1-152/45(4-6), 2x1-120/45(1-3)
			2	MR492	1916		
			3	MR493	1916		
			4	MR494	1916		
			5	MR495	1916		
			6	MR496	1916		

[home](#)[World navies yesterday](#)[1935](#)

Siam 01 January 1935

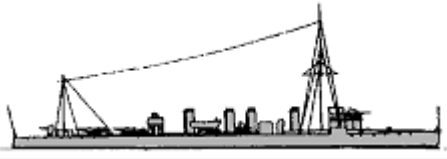
TORPEDO SHIPS

DD	Sua Tayanchon	2	1	Sua Tayanchon	1908		385t, 69.2ppx6.6x1.8m, 4b,2vte, 6000hp, 27kts, 75p; 1x1-76/40, 5x1-57/40, 2x1-450TT
			2	Sua Khamronsin	1912		
	Phra Ruang	1	3	Phra Ruang	1917		1208t, 83.6x8.3x2.7m, 3b,2gt, 27000hp, 36kts, 82p; 3x1-102/40, 1x1-76/40, 1x1-40/39, 2x2-533TT
TB	No1		1	No2	1908		100t, 41.1x4.9x2.1m, 2b,1vte, 1200hp, 23kts, 29p; 1x1-57/40, 1x1-47/43, 2x1-450TT
			2	No3	1908		
			3	No4	1913		

ESCORTS

SL	Chow Phraya	1	1	Chow Phraya	1919		840t, 70.4x8.7x2.2m, 2b,2vte, 2200hp, 16kts, 65p; 1x1-102/40, 1x1-76/40
----	-------------	---	---	-------------	------	--	---

OTHER FIGHTING SHIPS

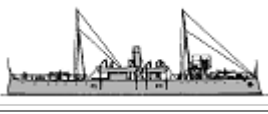
PG	Muratha		1	Bali	1900		580t, 49.4x7.0x3.1m, 2b,2vte, 500hp, 11.4kts, 83p; 1x1-120/40, 5x1-57/40, 4x1-37/23
			2	Sugrib	1901		
	Sri Monthon	1	3	Sri Monthon	1908		225t, 41.8x5.5x2.0m, 1b,2vte, 750hp, 14.5kts, 34p; 2x1-57/40

	Ratanakosindra	2	4	Ratanakosindra	1925		1000t, 53.0x11.3x3.3m, 2b,2vte, 850hp, 12kts, 102p; 57belt, 50deck, 38turrets, 120CT; 2x1-152/50, 4x1-76/40
			5	Sukothai	1930		

COASTAL FORCES

PT	No1	5	1-5	No1-5	1922		14t, 16.8x3.4x1.1m, 2pe, 750hp, 37kts, 5p; 2-450TT
----	-----	---	-----	-------	------	---	--

© Ivan Gogin, 2011-15

[home](#)[World navies yesterday](#)[1935](#)

SOVIET UNION 01 January 1935

IN SERVICE: 3 battleships, 1 heavy cruiser, 2 protected cruisers, 2 light cruisers, 17 destroyers, 76 submarines, 10 corvettes, 12 gunboats, 6 dispatch vessels, 8 auxiliary dispatch vessels, 8 river monitors, 5 river gunboats, 2 auxiliary river gunboats, 123 motor torpedo boats, 1 patrol motor launch, 16 armoured river motor gunboats, 4 minelayers, 8 auxiliary minelayers, 1 river minelayer, 10 minesweepers, 12 auxiliary minesweepers, 5 Board Guard ships, 2 auxiliary Board Guard ships, 32 Board Guard launches

CAPITAL SHIPS

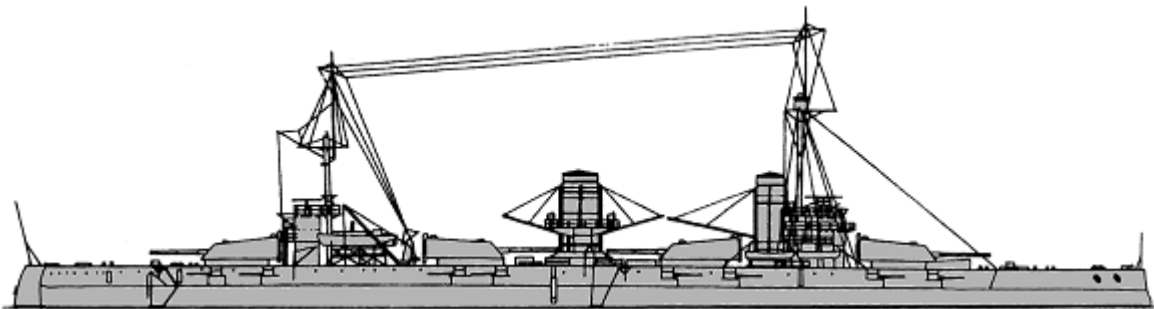
BB	Sevastopol	1	Oktyabrskaya Revolyutsiya	1914		<p>26900(2)-26700(1,3)t, 184.9x26.9x8.4m, 12b(1)-25b(2)-22b(3),4t, 60600(1)-42000(2)-61100(3)hp, 22.5(1)-23(2)-23.8(3)kts, 1140p; 225belt, 75deck, 305turrets, 250CT; 4x3-305/52, 16x1-120/50, 6x1-76/30, 4x1-45/46(1), 4-450TT, 1seaplane (Ju20)(1,2)</p>
		2	Parizhskaya Kommuna	1914		
		3	Marat	1915		

CRUISERS

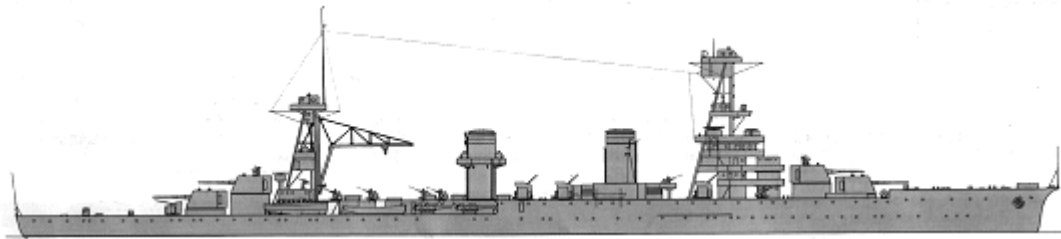
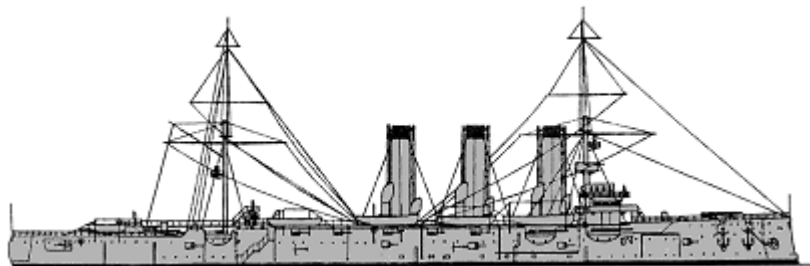
CA	Krasny Kavkaz	1	1	Krasny Kavkaz	1932		<p>8888t, 169.5x15.7x6.6m, 10b,4t, 55000hp, 29kts, 850p; 75belt, 45deck, 25turrets, 75CT; 4x1-180/60, 4x1-102/45, 4x3-450TT, 100m, 2seaplanes (KR-1)</p>
	Pallada	1	1	Avrora	1903		<p>6897t, 126.8x16.8x6.4m, 24b,3vte, 11610hp, 19.2kts, 570p; nickel steel: 38/63deck, 25shields, 152CT; 10x1-130/55, 4x1-76/30, 126m</p>

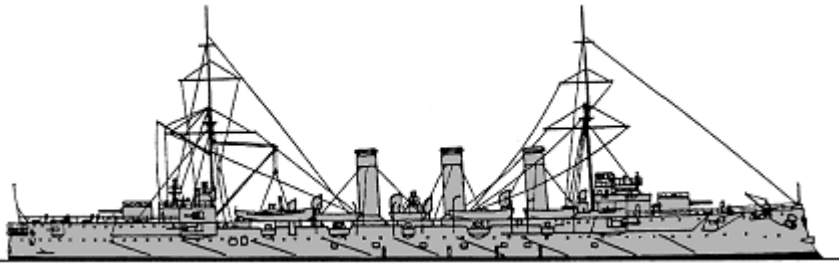
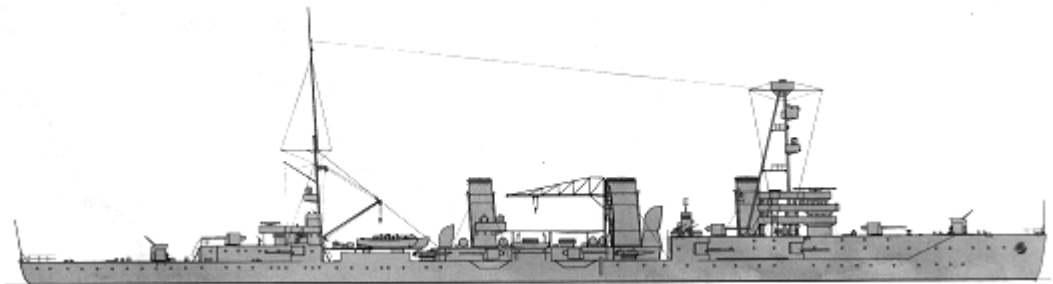
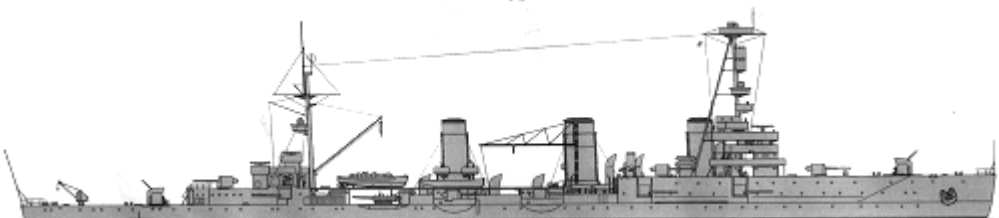

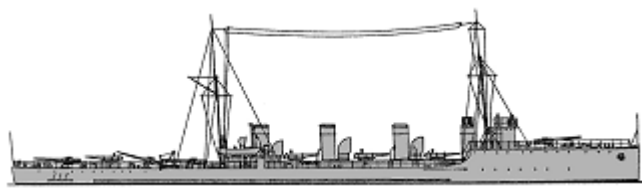
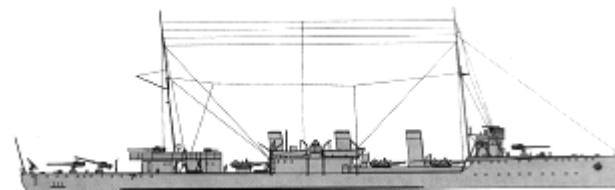
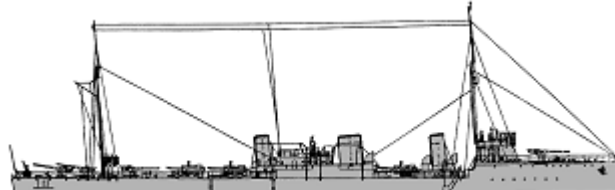

CL	Bogatyr	1 2	Komintern	1905		7790t, 134.0x16.6x6.3m, 12b,2vte, 5000hp, 12kts, 581p; 35/70deck, 127turrets, 80casemates, 140CT; 10x1-130/55, 4x1-76/30, 2-450TT, 290m
	Admiral Nakhimov	1 3	Chervona Ukraina	1927		8268t, 166.8x15.7x6.2m, 14b,4t, 55000hp, 29kts, 830p; 75belt, 40deck, 25shields, 75CT; 15x1-130/55, 4x1-75/50, 4x3-450TT, 90m, 1seaplane (MU-2)
	Svetlana	1 4	Profintern	1928		8041t, 158.4x15.4x6.7m, 13b,4t, 46300hp, 29kts, 830p; 75belt, 40deck, 25shields, 75CT; 15x1-130/55, 4x1-75/55, 4x3-450TT, 90m, 1seaplane (MU-2)

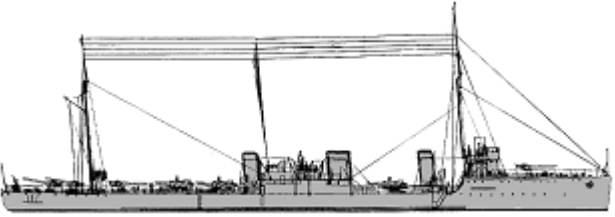
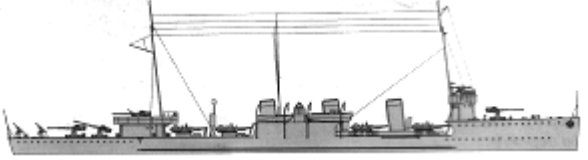
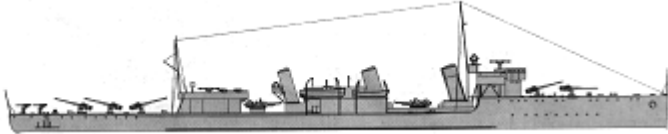

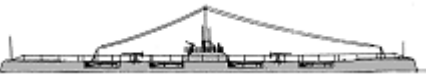

TORPEDO SHIPS

DD	Novik	1 1	Yakov Sverdlov	1913		1595t, 102.4x9.5x3.5m, 6b,3t, 35100hp, 36kts, 113p; 4x1-102/60, 1x1-76/30, 3x3-450TT, 2DCR, 58m
	Schastlivy	1 2	Frunze	1915		1450t, 98.0x9.3x3.4m, 5b,2t, 23000hp, 34kts, 112p; 4x1-102/60, 1x1-76/30, 3x3-450TT, 2DCR, 40m
	Pobeditel	3	Volodarskiy	1915		1450t, 98.0x9.3x3.2m, 4b,2t, 30000hp, 35kts, 112p; 4x1-102/60, 1x1-76/30(3-6), 1x1-40/39(7), 4x1-12.7(5,6), 3x3-450TT, 2DCR(3-6), 58m(3-6), 80m(7)
		4	Uritskiy	1915		
		5	Engels	1916		
6		Artyom	1916			
Kapitan Izylmetyev	7	Stalin	1916		1450(8,9)-2020(10,11)t, 98.0x9.3x3.9(8,9)-4.0(10,11)m, 4b,2t, 31500hp, 34kts, 150p; 4x1-102/60, 1x1-76/30, 2x1-45/46(9), 3x3-450TT, 2DCT(10,11), 2DCR, 58(8,9)-50(10,11)m	
	8	Lenin	1916			
	9	Voykov	1916			
	10	Rykov	1927			
	11	Karl	1928			

						
		Libknekht				
Fidonisi	4	12 Dzerzhinskiy	1917		1760t, 92.5x9.1x3.8m, 5b,2t, 29000hp, 33kts, 136p; 4x1-102/60, 2x1-76/30, 4x3-450TT, 2DCR, 60m	
		13 Nezamozhnik	1923			
		14 Petrovskiy	1925			
		15 Shaumyan	1925			
Izyaslav	2	16 Karl Marx	1917		1570t, 107.0x9.5x4.1m, 5b,2t, 32700hp, 35kts, 150p; 5x1-102/60, 1x1-76/30, 3x3-450TT, 80m	
		17 Kalinin	1927			

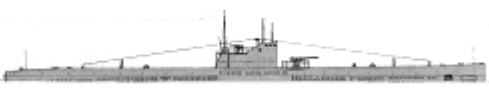
SUBMARINES

Bars	8	1 B-1	1916		670/810t, 68.0x4.5x4.3m, 2d/em, 500/900(1-6,8)-2640/900(8)hp, 12/8(1-6,8)-17/8.7(7)kts, 44p, 50m; 1x1-75/50(1,2,5,8), 2x1-75/50(3,4), 1x1-63/38(1,2,5-8), 1x1-37/30, 4-450TT(1), 12-450TT(2-8)
		2 U-1 (TS)	1916		
		3 B-2	1916		
		4 B-3	1916		
		5 B-7	1917		
		6 B-6	1917		
		7 B-8	1917		
		8 B-4	1917		
AG	4	9 A-1	1920		355/434t, 46.0x4.9x3.8m, 2d/em, 960/480(9,10,12)-960/640(11,13)hp, 13/8(9,10,12)-13/10.5(11,13)kts, 24p, 50m; 1x1-45/46(9,10,12), 4-450TT
		10 A-2	1921		
		11 A-3	1922		
		12 A-4	1923		
		13 A-5	1918		
ser. I	6	14 D-1	1930		933/1354(14-16) -945/1355(17) -989/1385(18,19), 76.0(14-16) -76.6(17-19)x6.4x3.8(14-16,18,19) -4.3(17)m, 2d/em, 2200/1050hp, 14/9(14-16) -12.5/8.2(17) -11.3/8.7(18,19)kts, 47p, 75m; 1x1-102/45, 1x1-37/30, 8-533TT
		15 D-2	1931		
		16 D-3	1931		
		17 D-4	1930		
		18 D-5	1931		
		19 D-6	1931		
L50	1	20 L-55	1918		954/1139t, 71.6x7.2x4.1m, 2d/em, 2200/1600hp, 13.5/8.2kts, 49p, 50m; 2x1-75/50, 6-533TT
Ser.		21 L-1	1933		1040/1335(21,22)-1051/1327(23)-1038/1330(24,25)t, 78.0(21-23,25) -78.5(24)x7.3(21,22) -7.2(23,25) -7.0(24)x4.0(21-23) -4.2(24)
		22 L-2	1933		

SS	II	5	23	L-3	1933		-4.3(25)m, 2d/em, 2200/1300hp, 14.8/8.5(21-23)-12.5/8.2(24) -13.8/8.3(25)kts, 55p, 75m; 1x1-102/45, 1x1-45/46(21-23,25), 6-533TT, 17m(21,22), 20m(23-25)
			24	L-4	1933		
			25	L-5	1933		
	Ser. III	4	26	Shch-301	1933		578/706t, 57.0x6.2x3.9m, 2d/em, 1000(26,27)-1370(28,29)/800hp, 11.6(26,27)-12.5(28,29)/8.5kts, 41p, 75m; 1x1-45/46, 6-533TT
			27	Shch-302	1933		
			28	Shch-303	1933		
			29	Shch-304	1934		
	Ser. V	12	30	Shch-101	1933		585/700t, 58.5x6.2x3.9m, 2d/em, 1370/800hp, 11.9/8.5kts, 40p, 75m; 2x1-45/46, 6-533TT
			31	Shch-102	1933		
			32	Shch-103	1933		
			33	Shch-104	1933		
			34	Shch-105	1933		
			35	Shch-106	1933		
			36	Shch-107	1933		
			37	Shch-108	1933		
			38	Shch-109	1934		
			39	Shch-110	1934		
	Ser. V-bis	6	42	Shch-113	1934		601/772(42-46) -586/702(47)t, 58.0(42-46)-58.8(47)x 6.2x3.9(42-46)-4.2(47)m, 2d/em, 1370/800hp, 12/8(42-46)-12.9/7(47)kts, 40p, 75m; 1x1-45/46(42-46), 2x1-45/46(47), 1x1-12.7(42-46), 6-533TT
43			Shch-114	1934			
44			Shch-115	1934			
45			Shch-117	1934			
46			Shch-118	1934			
		Shch-					



		47	305	1934		
Ser. VI	29	48	M-1	1934		161/201t, 36.9x3.1x2.6m, 1d/em, 685/240hp, 11.1/6.4kts, 19p, 50m; 1x1-45/46, 2-533TT
		49	M-2	1934		
		50	M-3	1934		
		51	M-4	1934		
		52	M-5	1934		
		53	M-6	1934		
		54	M-7	1934		
		55	M-8	1934		
		56	M-9	1934		
		57	M-10	1934		
		58	M-11	1934		
		59	M-12	1934		
		60	M-13	1934		
		61	M-14	1934		
		62	M-15	1934		
		63	M-16	1934		
		64	M-17	1934		
		65	M-18	1934		
		66	M-19	1934		
		67	M-20	1934		
68	M-21	1934				
69	M-22	1934				
70	M-23	1934				
71	M-24	1934				
72	M-25	1934				
73	M-26	1934				
74	M-27	1934				
75	M-51	1934				
76	M-52	1934				

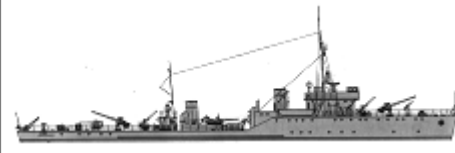

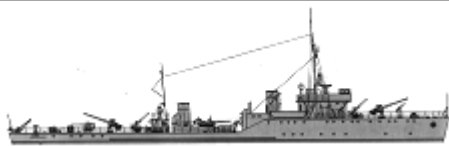

ESCORTS

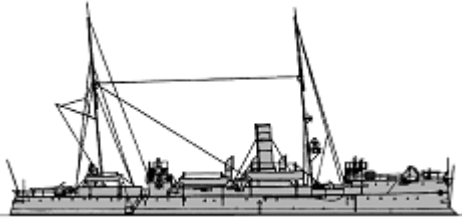
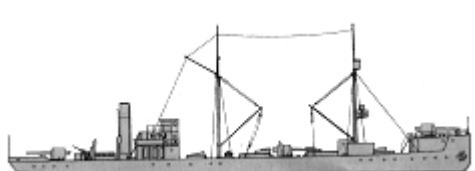
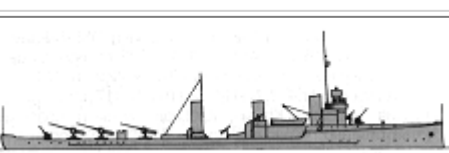
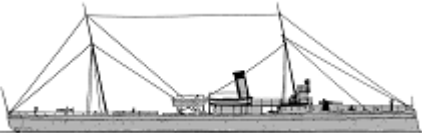
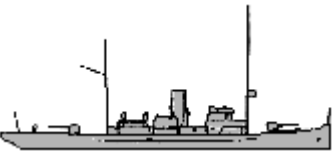
FS	pr. 2	8	1	Uragan	1930		534t, 71.5x7.4x2.5m, 2b,2gt, 6300hp, 26kts, 85p; 2x1-102/60, 4x1-45/46, 1x3-450TT, 32m
			2	Tayfun	1931		
			3	Smerch	1932		
			4	Tsiklon	1932		
			5	Groza	1932		
			6	Vikhr	1932		
			7	Shtorm	1932		
			8	Shkval	1933		

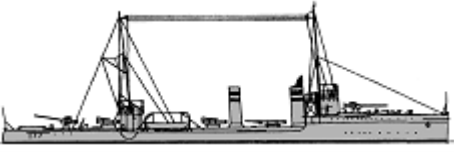
pr. 4	2	9	Metel	1934		531t, 71.5x7.4x2.3m, 2b,2gt, 6300hp, 25kts, 101p; 2x1-102/60, 3x1-45/46, 1x3-450TT, 32m
		10	Vyuga	1934		









OTHER FIGHTING SHIPS

PG	Khrabry	1	1	Krasnoye Znamya	1897		2100t, 72.3x12.7x3.4m, 8b,2vte, 2100hp, 14kts, 188p; Harvey steel: 127belt, 38deck, 38shields, 25CT; 5x1-130/55, 11x1-47/43, 1-450TT, 20m
				Kars	2	3	Lenin
	Krasny Azerbaydzhan	1910					
	Elpidifor	4	5	Krasnaya Abkhaziya	1920		1300t, 74.7x10.4x1.8m, 2b,2vte, 750hp, 8.5kts, 169p; 3x1-130/55, 2x1-76/30, 180m, MS; 2000troops or 6 light tanks
				Krasny Adzharistan	1921		
				Krasny Krym	1924		
Krasnaya Gruziya				1923			
Ukrayna	3	10	Bakinskiy Rabochiy	1905		880t, 73.2x7.2x3.4m, 4b,2vte, 7000hp, 26kts, 88p; 3x1-102/60, 1x1-76/30	
		11	Markin	1905			
		12	Altfater	1905			
DV	Abrek	1	1	Abrek	1897		675t, 65.5x7.8x3.4m, 4b,2vte, 4500hp, 21.2kts, 88p; 4x1-75/50, 1x1-37/23
	Kopchik	1	2	Pioner	1916		550t, 51.2x7.3x2.9m, 3b,2vte, 1500hp, 15kts, 57p; 2x1-102/60, 1x1-76/30, 30m
	Inzhener-Mekhanik Zverev	1	3	Artemyev (TS)	1906		540t, 63.6x7.0x2.7m, 4b,2vte, 6000hp, 27kts, 65p; 2x1-75/50
	Vsadnik	1	4	Zheleznyakov	1907		930t, 71.9x7.2x2.4m, 4b,2vte, 6500hp, 99p; 2x1-102/60, 1x1-37/23

	Dozorny	1	5	Razvedchik	1905		100t, 30.8x5.0x1.7m, 2b,1vte, 660hp, 16kts, 31p; 1x1-37/23
	Berezina	1	6	Yauza (TS)	1918	No picture	450t, 50.7x16.7x2.0m, 2d(sw), 600hp, 7.5kts, 47p; 2x1-75/50
ADV	-	8	1	Polyarnaya Zvezda	1891		3949t; 106.5x13.8x5.2m, 6000hp, 17kts; 4x1-47/43
			2	Shtandard	1896		5557t, 112.8x15.4x6.6m, 12000hp, 20kts; 8x1-47/43
			3	Izhora	1913		210t
			4	Minyor	1914		150t
			5	Yakobinets	1905		140t
			6	Kingisepp	1900		212t
			7	Krasny Adzharets	1900		100t
			8	Krasny Vypel	1911		700t; 4x1-75/50
RMON	Tayfun	7	1	Vostretsov	1910		1000t, 70.9x12.8x1.4m, 4d, 1000(1,2,4-7)-2970(3)hp, 10(1,2,4-7)-16.5(3)kts, 117p; 76belt, 19deck, 76turrets, 51CT; 4x1-152/50(6), 4x1-130/55(1,3,4), 4x2-120/50(2,5,7), 2x1-76/30(1,2,4-7)
			2	Lenin	1910		
			3	Dalnevostochny Komsomolets	1910		
			4	Triandafilov	1910		
			5	Krasny Vostok	1910		
			6	Sverdlov	1910		
			7	Sun-Yat-Sen	1910		
		pr. SB-12	1	8	Udarny	1934	
PGR	Buryat	2	1	Buryat	1907		288t, 54.5x8.2x0.9m, 2b,2vte, 480hp, 11.5kts, 40p; 12belt, 5deck, 8CT; 2x1-76/40
			2	Mongol	1907		
	Vogul	3	3	Bednota	1909		349t, 54.5x8.2x1.2m, 2b,2vte, 480hp, 10.5kts, 63p; 13belt, 9deck, 13CT; 2x1-102/60, 1x1-76/30
			4	Proletariy	1909		
			5	Krasnoye Znamya	1909		
APR	-	2	1	Verny	1898		350t; 2x1-102/60, 1x1-76/30
			2	Peredovoy	1891		328t; 2x1-102/60, 1x1-76/30







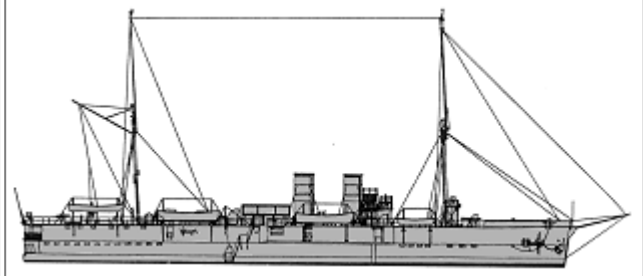

COASTAL FORCES

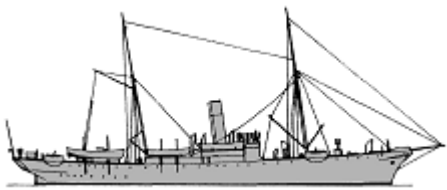

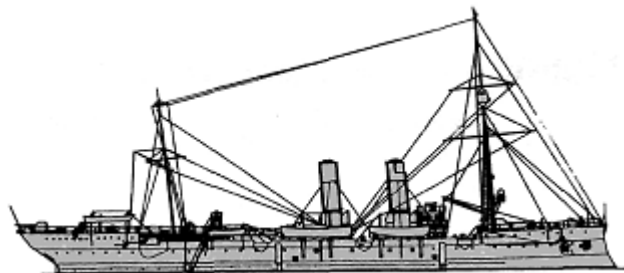
	No1	5	1 - 5	No1, 2, Pilot, 6, No7, 9			1906		35t, 27.4x3.7x1.5m, 2pe, 600hp, 20kts, 11p; 1x1-47/43, 1x1-450TT
	ANT-3	1	6	Pervenets			1927		9t, 17.3x3.3x0.9m, 2pe, 1200hp, 54kts, 3p; 1-450TT, 2m
	ANT-4	1	7	No14 Tupolev			1928		10t, 16.8x3.3x0.8m, 2pe, 1200hp, 50.5kts, 5p; 2-450TT, 2m

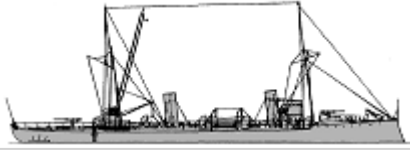
PT	Sh-4	61	8 - 68	No11, 11, 12, 12, 12, 13, No13 Proletariy Ukrainy, No14, 21, 21, 22, 22, 22, 23, No23 Sibiryak, No24 Pioner, No31, 31, 32, 32, 32, 33, 33, 34, 41, 41, 42, 42, 42, 43, 43, 44, 51, 51, 52, 52, 52, 53, 53, No53 Partizan, 54, No55 Revolyutsionny Metallist, No61, 61, 61, 62, 62, 63, 63, 63, 64, 64, 73, 74, 84, No92 Osoaviakhimovets, No102, 102, 114, 124, 124	1928 - 1932		10t, 16.8x3.3x1.0m, 2pe, 1200hp, 45kts, 5p; 2-450TT
	S	2	69, 70	No72, 82	1931		28t, 23.5x3.8x1.9m, 3pe, 2250hp, 27kts, 6p; 3-450TT
	ANT-5	1	71	No1	1933		15t, 19.1x3.4x1.2m, 2pe, 2000hp, 58kts, 6p; 2-533TT, 4m
	G-5	52	72 - 123	No11, 122, 13, 15, 17, 21, 23, 25, 27, 31, 33, 35, 37, 41, 43, 45, 47, 51, 53, 55, 57, 61, 63, 65, 67, 71, 71, 73, 75, 112, 81, 83, 83, 85, 91, 93, 93, 95, 101, 103, 103, 105, 111, 113, 121, 123, 131, 141, 151, 161, 171, 181	1933 - 1934		15t, 19.1x3.3x1.2m, 2pe, 1700hp, 45-52kts, 6p; 2-533TT
YP	Greenport-4	1	1	No1	1917		24t, 22.0x3.4x0.6m, 3pe, 1080hp, 30kts, 8p; 1x1-47/43, 1x1-37/23
PGRA	Kopyo	2	1, 2	BK-103, 104	1910		25t, 22.2x3.1x0.5m, 2pe, 200hp, 14.5kts, 12p; 8belt, 8deck, 8CT: 1x1-76/16
	K	4	3 - 6	BK-105, 107-109	1917		25t, 20.4x3.2x0.6m, 2pe, 150hp, 12.5kts, 12p; 5belt, 4deck, 6shields, 6CT; 2x1-76/16
	N	4	7 - 10	BK-110-113	1916 - 1917		18t, 15.2x3.1x0.7m, 2pe, 100hp, 11.5kts, 8p; 7belt, 5deck, 7turret, 7CT; 1x1-76/16
	D	4	11 - 14	BK-1-4	1916 - 1917		7t, 9.2x2.4x0.7m, 1pe, 80hp, 10.5kts, 7p; 5belt, 6turret, 6CT
	Partizan	2	15, 16	BK-101, 102	1932	No picture	56t, 32.0x3.4x0.9m, 2pe, 100hp, 10kts, 13p; 5belt, 5CT; 1x1-76/30

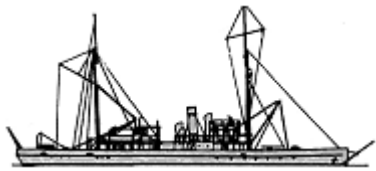

MINE WARFARE SHIPS

General-Admiral	1	1	25 Oktyabrya	1875		5031t, 91.0x14.6x7.0m, 6b,1vc, 4470hp, 12.3kts, 490p; iron: 152belt, 25deck; 2x1-75/50, 2x1-47/43, 8x1-37/20, 1-381TT, 500m
-----------------	---	---	--------------	------	--	---

ML	Bug	1	2	Gidrograf	1893		1490t, 62.2x10.4x4.6m, 4b,2vte, 13kts, 226p; 1x1-76/30, 350m
	Volga	1	3	9 Yanvarya (TS)	1909		1711t, 70.3x11.9x4.4m, 4b,2vte, 1600hp, 13.5kts, 219p; 4x1-47/43, 230m
	Amur	1	4	Amur	1909		2926t, 98.9x14.0x4.4m, 12b,2vte, 5000hp, 16kts, 312p; 5x1-120/45, 2x1-75/50, 320m
AML		8	1	Mina	1913		180t; 80m
			2	Astrakhan	1913		3725t, 91.1x12.3x5.2m, 2b,1vte, 1150hp, 9.8kts; 2x1-102/60, 2x1-76/30, 1x1-45/46, 820m
			3	Stavropol	1907		2300t, 63.5x10.0x4.6m, 2b,1vte, 750hp, 10.5kts; 4x1-76/30, 268m
			4	Erivan	1912		4690t, 87.2x12.2x5.1m, 2b,1vte, 1200hp, 9kts; 2x1-102/60, 2x1-75/50, 1x1-37/23, 500m
			5	Teodor Nette	1912		3765t, 91.1x12.3x4.8m, 2b,1vte, 1200hp, 9kts; 1x1-102/60, 2x1-76/30, 1x1-45/46, 200m
			6	Tomsk	1913		4466t, 92.0x12.3x5.2m, 2b,1vte, 1200hp, 9kts; 9x1-45/46, 420m
			7	Yana	1923		2273t, 96.8x11.6x4.5m, 1600hp, 10kts
			8	Kolkhoznik	1931		210t; 2x1-76/30, 60m
MLR	Silny	1	1	Silny	1910		300t, 55.7x16.6x1.5m, 1b,1vc, 450hp, 10kts, 71p; 1x1-76/30, 100m
MS	Inzhener-Mekhanik Zverev	1	1	Martynov (TS)	1906		540t, 63.6x7.0x2.7m, 4b,2vte, 6000hp, 27kts, 65p; 2x1-75/50, MS, 16m
	Dozorny	1	2	Dozorny (TS)	1905		100t, 30.8x5.0x1.7m, 2b,1vte, 660hp, 16kts, 31p; 1x1-37/23, MS
	Minrep	1	3	Zapal	1912		205t, 45.0x6.1x2.5m, 2b,2vde, 300hp, 11.5kts, 37p; 1x1-76/30, 1x1-45/46, MS, 32m
	Iskra	2	4	T-33	1914		420t, 44.5x7.5x3.3m, 1b,1vte, 650hp, 11.6kts, 49p; 1x1-76/30, 1x1-45/46, MS
5			T-31	1914			

Kapsyul	2	6	Kapsyul	1916		271t, 53.0x6.6x1.2m, 2b,2vte, 650hp, 9kts, 38p; 1x1-75/50, MS
		7	Gruz	1916		
	Udarnik	2	8	Udarnik	1917	
9			Klyuz	1917		
Dzhalita	1	10	No11	1926		470t, 40.5x6.2x2.9m, 2b,2vte, 300hp, 8kts, 39p; 1x1-45/46, MS
AMS -	12	1	No11	1931		1306t, 51.1x9.0x4.8m, 1b,1vte, 675hp, 9.7kts; 1x1-102/60, MS
		2	No12	1933		1250t, 54.8x9.4x5.0m, 1b,1vte, 650hp, 8.5kts; 1x1-102/60, MS
		3	No13	1930		1250t, 54.8x9.0x4.4m, 1b,1vte, 770hp, 10kts; 1x1-102/60, MS
		4	No14	1930		1107t, 49.3x8.5x4.8m, 1b,1vte, 675hp, 9kts; 1x1-102/60, MS
		5	Zmey	1914		245t
		6	Buy	1900		325t
		7	Barometr	1914		230t
		8	No15	1921		480t
		9	No16	1921		480t; 1x1-75/50
		10	No17			105t
		11	No18	1935		447t
		12	No21	1898		500t

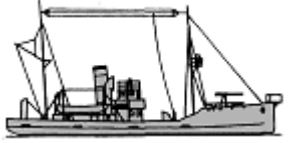
BOARD GUARD SHIPS

PC	Barsuk	2	1	Atarbekov	1916		202t, 30.5x5.8x2.7m, 1b,1vte, 350hp, 11kts, 46p; 2x1-75/50
			2	Mogilevskiy	1916		
	T.13	1	5	PS-1	1916		580t, 43.2x7.2x3.5m, 1b,1vte, 500hp, 11kts, 35p; 1x1-57/50, MS, 30m
APC	-	2	1	Sovetskiy Azerbaydzhan	1893		1091t, 74.8x9.6x4.0m, 640hp, 14kts; 2x1-130/55
			2	Vorovskiy	1901		3315t, 96.6x12.2x5.5m, 6000hp, 18kts; 2x1-120/45
YP	K-105	3	1 - 3	K-105, 108, 240	1928	No picture	29t, 22.6x3.8x1.5m, 300hp, 12kts, 13p; 1x1-45/46
	K-1	5	4 - 8	K-391 - 395	1928	No picture	15t, 12.9x2.9x1.4m, 100hp, 8kts, 9p
	GK-1	2	9, 10	K-230, 231	1930	No picture	20t, 22.5x3.9x1.1m, 2pe, 1000hp, 23kts, 13p; 1x1-12.7
	ZK	15	11 - 25	K-193-196, 206-208, 220, 325-331	1931 - 1932		19t, 19.8x3.3x1.2m, 2pe, 600hp, 16kts, 12p; 1x1-45/46
	K-229	1	26	K-229	1931	No picture	23t, 22.5x3.9x1.3m, 1700hp, 12p; 1x1-12.7
	GK	2	27, 28	K-232, 233	1931		30t, 24.0x3.9x1.1m, 2pe, 1650hp, 23kts, 10p; 1x1-45/46

						
K-17	1	29	K-396	1931	No picture	17t, 18.9x3.6x1.4m, 600hp, 11kts, 9p
K-164	1	30	K-164	1932	No picture	14t, 12.9x2.7x1.2m, 100hp, 9.9kts, 7p
K-18	1	31	K-397	1932	No picture	14t, 13.6x2.8x1.7m, 300hp, 7kts
BK-02	1	32	PK-224	1934	No picture	75t, 26.9x4.0x1.9m, 3pe, 2550hp, 18kts, 20p; 2x1-45/46, 2x1-12.7, 2DCR, 4m

© Ivan Gogin, 2011-14

[home](#)

[World navies yesterday](#)

[1935](#)

Spain 01 January 1935

CAPITAL SHIPS

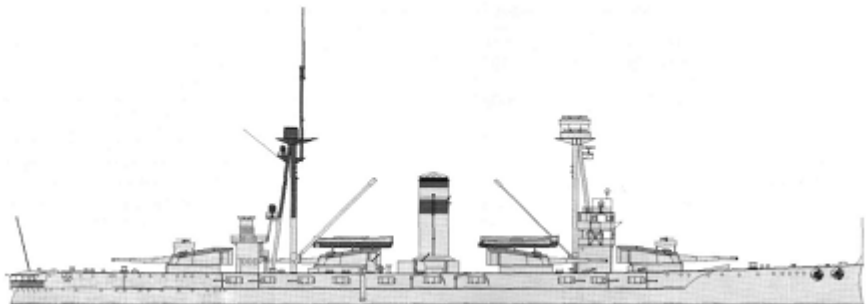
		1	España	1915		<p>15700t, 139.9x24.0x7.8m, 12b,4t, 15500hp, 19.5kts, 854p; 230belt, 90deck, 234turrets, 250CT; 4x2-305/50, 20x1-102/50, 2x1-76/34</p>
BB	España	2	Jaime I	1921		

AIRCRAFT CARRYING SHIPS

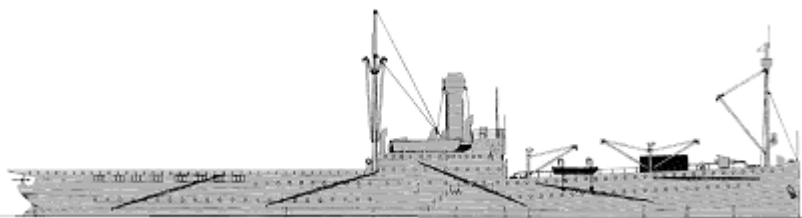

						<p>9900t, 128.0x16.8x7.4m, 3b,1vte, 2200hp, 10kts, 398p; 2x1-105/35, 2x1-57/42, 20seaplanes (M.18), 1airship (SCA), 2balloons</p>
AV	Dédalo	1	Dédalo	1901		

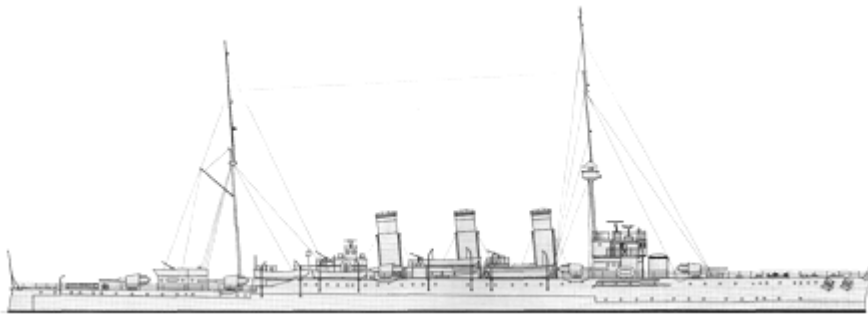
CRUISERS

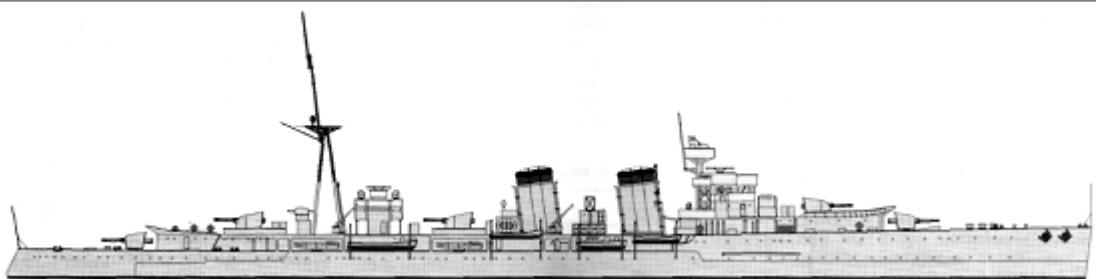

						<p>6450t, 140.8x15.2x4.8m, 12b,2t, 25500hp, 25kts, 404p; 50belt, 38deck, 152shields, 152CT; 9x1-152/50, 1x1-76/19, 4x1-47/50, 2x2-533TT</p>
	Reina Victoria Eugenia	1	República	1923		

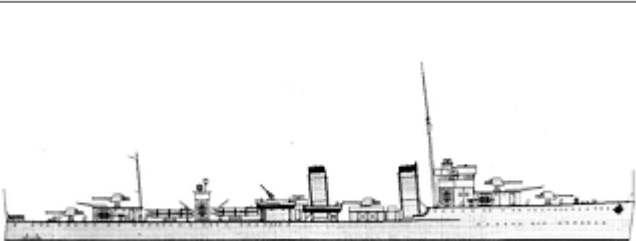
CL	Méendez Núñez	1	2	Méendez Núñez	1924		6045t, 140.8x14.1x4.4m, 12b,4gt, 45000hp, 29kts, 343p; 76belt, 25deck, 150CT; 6x1-152/50, 1x1-76/19, 4x1-47/50, 4x3-533TT
	Príncipe Alfonso	3	3	Libertad	1925		
4			Almirante Cervera	1927			
5			Miguel de Cervantes	1930			
							9237t, 176.6x16.5x5.0m, 8b,4gt, 80000hp, 33kts, 564p; 76belt, 50deck, 13shields, 150CT; (3x2+2x1)-152/50, 4x1-102/45, 2x1-47/50, 4x3-533TT

TORPEDO SHIPS

DD	Alsedo	3	1	Alsedo	1924		1337t, 86.8x8.2x4.5m, 4b,2gt, 33000hp, 34kts, 86p; 3x1-102/45, 2x1-47/50, 2x2-450TT, 1DCR, 60m
			2	Velasco	1924		
			3	Lazaga	1925		
DD	Churucca	7	4	Sánchez Barcáiztegui	1928		2087t, 102.0x9.7x3.2m, 4b,2gt, 42000hp, 36kts, 190p; 5x1-120/45, 1x1-76/45, 2x3-533TT, 2DCR
			5	Almirante Ferrándiz	1929		
			6	José Luis Díez	1929		
			7	Lepanto	1930		
			8	Churucca	1931		
			9	Alcalá Galiano	1931		
			10	Almirante Valdés	1933		
TB	T-1	12	1	T-2	1912		190t, 52.3x5.0x1.5m, 2b,3(1-3)-2(4-12)t, 3750hp, 26kts, 31p; 3x1-47/50, (1x2+1x1)-450TT
			2	T-3	1912		
			3	T-7	1915		
			4	T-9	1915		
			5	T-14	1916		
			6	T-15	1917		
			7	T-16	1917		
			8	T-17	1917		
			9	T-18	1918		
			10	T-19	1920		
			11	T-20	1920		
			12	T-21	1921		

SUBMARINES

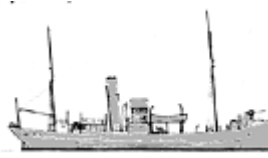
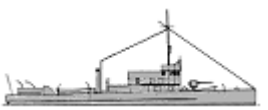

SS	B1	1	B1	1922		556/740t, 64.2x5.6x3.4m, 2d/em, 1400/420hp, 16.2/10.5kts, 28p, 60m; 1x1-76/45, 4-450TT	
		2	B2	1922			
		3	B3	1922			
		4	B4	1923			
		5	B5	1925			
		6	B6	1926			
	C1	6	7	C1 Isaac Peral	1928		915/1143t, 75.3x6.3x4.1m, 2d/em, 2000/750hp, 16.5/8.5kts, 40p, 90m; 1x1-76/45(7,8,11,12), 1x1-76/50(9,10), 6-533TT
			8	C2	1928		
			9	C3	1929		
			10	C4	1929		
			11	C5	1930		
			12	C6	1930		

ESCORTS

PC	Uad Lucus	3	1	Uad Lucus	1917		547t, 40.8x7.2x2.8m, 1b,1vte, 480hp, 10.5kts, 39p; 1x1-76/50
			2	Uad Martin	1917		
			3	Uad Muluya	1917		
	Uad Kert	3	4	Uad Kert	1917		665t, 45.1x7.2x2.8m, 1b,1vte, 600hp, 11kts, 45p; 1x1-76/50(4,6), 2x1-76/50(5), 1x1-47/50(6)
			5	Arcila	1918		
			6	Xauen	1918		
Alcázar	3	7	Alcázar	1919		440t, 41.0x7.3x3.2m, 1b,1vte, 425hp, 11kts, 41p; 1x1-76/50, 1x1-57/42(9), 2x1-47/50(7)	
		8	Larache	1919			
		9	Tetuán	1919			
FPV	Condestable Zaragoza	8	1	Condestable Zaragoza	1919	No picture	150t, 24.5x6.0x2.7m, 1b,1vte, 300hp, 11kts, 11p; 1x1-42/42
			2	Cabo de Infantería Marina Garciolo	1919		
			3	Contramaestre Castelló	1919		
			4	Maquinista Macías	1919		
			5	Torpedista Hernández	1919		
			6	Marinero Cante	1919		
			7	Fogonero Bañobre	1919		
			8	Marinero Jarana	1919		

OTHER FIGHTING SHIPS

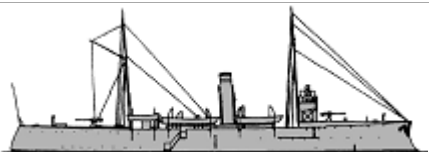
Recalde	2	1	Laya	1911	811t, 65.5x9.1x3.0m, 2b,2vte, 1200hp, 13.5kts, 130p; 4x1-76/50
		2	Lauria	1912	

PG	Antonio Cánovas del Castillo	3	3	Cánovas del Castillo	1923		1335t, 77.3x10.2x3.4m, 2b,2vte, 1700hp, 15kts, 132p; 4x1-102/45, 2x1-47/50
			4	Canalejas	1924		
			5	Dato	1925		
PR	Cabo Fradera	1	1	Cabo Fradera	1928		45t, 22.8x4.4x1.2m, 2pe, 121hp, 10.7kts, 16p; 1x1-42/42

COASTAL FORCES

YP	M1	3	1-3	H1-3	1918		37t, 24.4x3.7x1.2m, 2pe, 440hp, 19kts, 8p; 1x1-47/50, 2DCR, MS		
YP(Ta)	I1	6	C.I	21	1-21	C.I-XXI	1922-1925	No picture	36t, 22.8x4.0x1.4m, 2d, 180hp, 12kts, 6p
			22	I1	1923	No picture	128t, 33.5x2.6x1.8m, 2d, 600hp, 13kts		
			23	I2	1923				
			24	I3	1923				
			25	I4	1923				
			26	I5	1923				
			27	I6	1923				

AMPHIBIOUS SHIPS AND CRAFTS

LCT	K1	15	1	K2	1915		160t, 32.2x6.4x1.5m, 1sd, 60hp, 8kts, 15p; 300troops or 150t cargo
			2	K8	1915		
			3	K9	1915		
			4	K10	1915		
			5	K12	1915		
			6	K13	1915		
			7	K14	1915		
			8	K15	1915		
			9	K28	1915		
			10	K18	1915		
			11	K19	1915		
			12	K20	1915		
			13	K23	1915		
			14	K25	1915		
			15	K26	1915		

[home](#)[World navies yesterday](#)[1935](#)

Sweden 01 January 1935

CAPITAL SHIPS

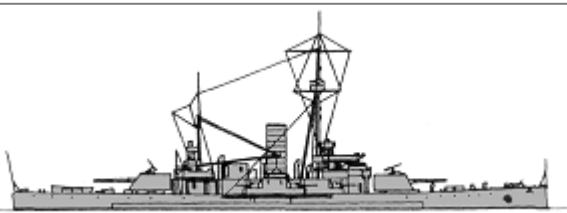
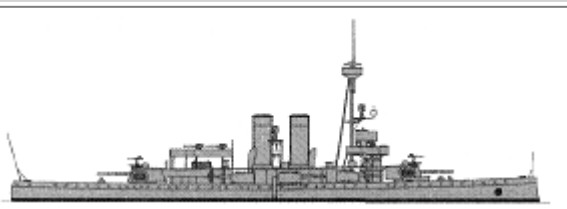
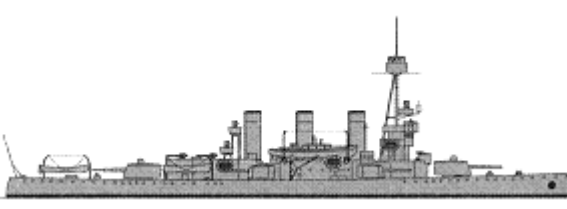
BC	Oden	1	Oden	1897		3715(1)-3720(2)t, 86.3x14.8x5.3m, 6b,2vte, 5350hp, 16.5kts, 254p; s(1)-h(2): 243(1)-240(2)belt, 49deck, 200(1)-190(2)turrets, 247(1)-190(2)CT; 2x1-254/42, 4x1-120/45(1), 6x1-120/45(2), 10x1-57/55	
		2	Thor	1899			
	Äran	4	3	Äran	1902		3735t, 89.7x15.0x5.0m, 8b,2vte, 6500hp, 17kts, 275p; 175belt, 48deck, 190turrets, 200CT; 2x1-210/44, 6x1-152/44, 10x1-57/55, 2x1-37/35, 2-450TT
			4	Wasa	1902		
			5	Tapperheten	1903		
			6	Manligheten	1904		
	Oscar II	1	7	Oscar II	1907		4584t, 95.6x15.4x5.5m, 10b,2vte, 9400hp, 18kts, 331p; 150belt, 50deck, 190turrets, 157CT; 2x1-210/44, 4x2-152/50, 10x1-57/55, 3x1-37/35, 2-450TT
	9	Drottning Victoria	1921				
	10	Gustaf V	1922				

AIRCRAFT CARRYING SHIPS

--	--	--	--	--	--	--	--	--	--



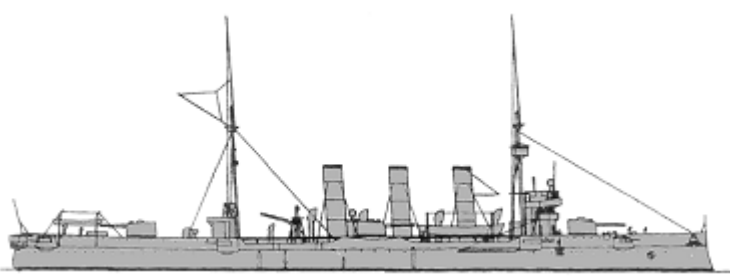
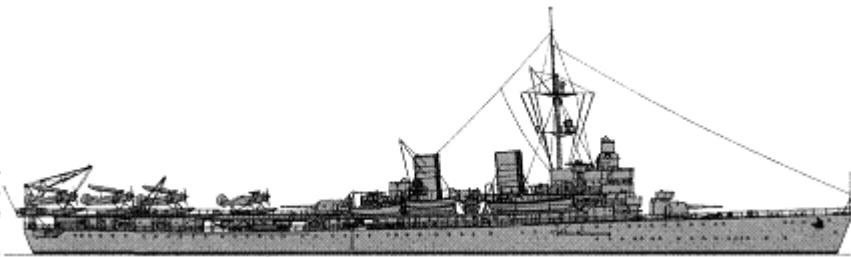
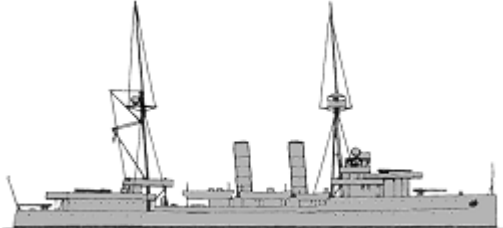

AV	Dristigheten	1	1	Dristigheten	1901		3600t, 89.0x14.8x5.2m, 8b,2vte, 5600hp, 16.8kts, 275p; h: 200belt, 50deck, 247CT; 4x1-75/50, 3seaplanes (Fairey III)
----	--------------	---	---	--------------	------	---	--

CRUISERS

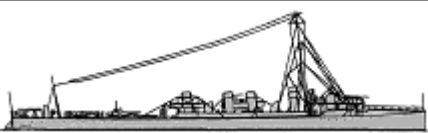

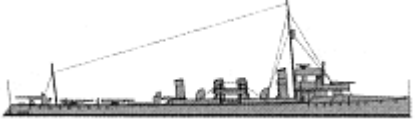
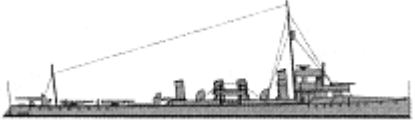
CA	Fylgia	1	1	Fylgia	1907		4734t, 115.1x14.8x6.3m, 12b,2vte, 12000hp, 21.5kts, 320p; 100belt, 35deck, 125turrets, 100CT; 4x2-152/50, 14x1-57/55, 2-450TT
CL	Gotland	1	1	Gotland	1934		5550t, 134.8x15.4x4.5m, 4b,2gt, 33000hp, 27.5kts, 480p; 24belt, 25deck, 25turrets, 19CT; (2x2+2x1)-152/55, (1x2+2x1)-75/60, 4x1-25/58, 2x3-533TT, 100m, 8seaplanes (Osprey)
CM	Clas Fleming	1	1	Clas Fleming	1914		1800t, 80.2x10.4x4.3m, 8b,2t, 6500hp, 20kts, 160p; 25deck, 75CT; 4x1-120/50, 100m

TORPEDO SHIPS

PGT	Örnen	3	1	Örnen	1897		844(1)-835(2)-814(3)t, 67.7(1,2)-70.7(3)x8.2(1,2)-8.3(3)x3.0m, 8b,2vte, 4000(1,2)-4500(3)hp, 20kts, 113p; 19deck; 2x1-120/45, 4x1-57/55, 1-380TT, 1seaplane (Fairey III, 2)
			2	Jacob Bagge	1898		
			3	Psilander	1900		
	Magne	1	1	Magne	1905		460t, 65.8x6.3x2.5m, 4b,2vte, 7200hp, 30kts, 67p; 6x1-57/55, 2x1-450TT
	Wale	1	2	Wale	1908		461t, 66.1x6.3x2.8m, 4b,2vte, 7665hp, 30kts, 54p; 2x1-75/50, 4x1-57/55, 2x2-450TT
			3	Vidar	1910		

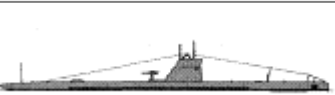
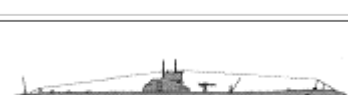
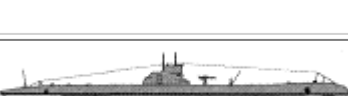
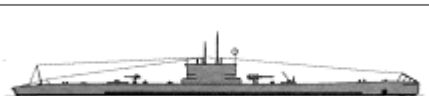

DD	Ragnar	3	4	Ragnar	1909		460t, 66.1x6.3x2.5m, 4b,2vte, 7200hp, 30kts, 54p; 4x1-75/50, 2x2-450TT
			5	Sigurd	1909		
	Hugin	2	6	Hugin	1911		500t, 66.3x6.5x2.1m, 4b,2t, 10000hp, 33kts, 72p; 4x1-75/50, 2x2-450TT
			7	Munin	1913		
	Wrangel	2	8	Wrangel	1918		498t, 72.0x6.9x2.4m, 4b,2gt, 13000hp, 34kts, 81p; 4x1-75/50, (2x2+2x1)-450TT
			9	Wachtmeister	1918		
	Ehrensköld	2	10	Ehrensköld	1927		1160t, 91.4x8.9x3.8m, 3b,2gt, 24000hp, 36kts, 120p; 3x1-120/45, 2x1-40/39, 2x3-533TT, 2DCT, 2DCR, 20m
			11	Nordenskjöld	1927		
	Klas Horn	2	12	Klas Horn	1932		1190t, 92.4x8.9x3.7m, 3b,2gt, 26000hp, 37kts, 119p; 3x1-120/45, 2x1-40/39, 2x3-533TT, 2DCT, 2DCR, 20m
			13	Klas Ugglå	1932		

SUBMARINES

SS	Svärdfiskan	2	1	Svärdfiskan	1915		252/370t, 45.5x4.2x3.0m, 2d/em, 1000/300hp, 14.2/8.5kts, 21p, 30m; 1x1-57/55, 2-450TT
			2	Tumlaren	1915		
	Laxen	1	3	Laxen	1915		140/170t, 26.8x3.6x3.0m, 2d/em, 700/200hp, 8.8/6.6kts, 10p, 30m; 1-450TT
			4	Abborren	1917		
	Abborren	2	5	Braxen	1917		174/310t, 31.0x3.6x3.1m, 2d/em, 920/280hp, 9.5/7.4kts, 14p, 30m; 2-450TT
			6	Hajen	1920		
	Hajen	3	7	Sälen	1920		422/600t, 54.0x5.2x3.5m, 2d/em, 2000/700hp, 15.5/9kts, 30p, 30m; 1x1-57/55, 4-450TT
			8	Valrossen	1920		
			9	Bävern	1921		
	Bävern	3	10	Illern	1921		472/650t, 57.0x5.8x3.0m, 2d/em, 2100/520hp, 15.2/8.2kts, 28p, 30m; 1x1-57/55, 4-450TT
			11	Uttern	1921		
			12	Valen	1925		
	Valen	1	12	Valen	1925		548/730t, 57.1x7.1x3.1m, 2d/em, 1340/700hp, 14.8/7.4kts, 31p, 60m; 1x1-75/50, 4-450TT, 20m
	Draken	3	13	Draken	1929		667/850t, 66.2x6.4x3.3m, 2d/em, 1920/1000hp, 13.8/8.3kts, 35p, 60m; 1x1-105/41, 4-533TT
			14	Gripen	1929		
15			Ulven	1931			

ESCORTS

			1	V27	1898		
--	--	--	---	-----	------	--	--

PC	Komet	11	2	V28	1899		120t, 39.8x4.8x2.5m, 1b,1vc, 1300hp, 23kts, 18p; 2x1-37/39, MS
			3	V29	1899		
			4	V30	1900		
			5	V31	1900		
			6	V32	1900		
			7	V33	1902		
			8	V34	1902		
			9	V35	1903		
			10	V36	1903		
			11	V37	1904		
			Plejad	16	12		
	13	V40			1908		
	14	V41			1908		
	15	V42			1908		
	16	V43			1909		
	17	V44			1909		
	18	V45			1909		
	19	V46			1909		
	20	V47			1909		
	21	V48			1910		
	22	V49			1910		
	23	V50			1910		
	24	V51			1909		
	25	V52			1909		
	26	V53			1910		
	27	V54			1910		
	Jägaren	2	28	Jägaren	1934		310t, 51.9x6.0x2.8m, 2b,1gt, 3600hp, 23kts, 41p; 2x1-75/60, 2x1-25/58, 2DCT
			29	Kaparen	1934		

COASTAL FORCES

PT	Mtb3	2	1, 2	Mtb3, 4	1925		13t, 16.2x3.4x1.1m, 2pe, 750hp, 40kts, 7p; 2-450TT, 4DC
PS	Asköfjärd	3	1-3	V71 Asköfjärd, V72 Baggensfjärd, V73 Nämdöfjärd	1931-1932	No picture	25t, 19.3x3.8x1.5m, 1d, 92hp, 11.5kts, 7p; 1x1-37/39
	Kanholmsfjärd	3	4-6	V74 Kanholmsfjärd, V75 Lidöfjärd, V76 Edöfjärd	1933	No picture	28t, 21.2x3.8x1.5m, 1d, 92hp, 11.5kts, 7p; 1x1-37/39

MINE WARFARE SHIPS

	Mul 3	1	1	Mul 3	1879	No picture	190t, 6.5kts; 20m
			2	Mul 5	1904		
			3	Mul 6	1904		

ML	Mul 5	4				No picture	120t, 7.5kts; 20m
			4	Mul 7	1904		
			5	Mul 8	1905		
	Mul 9	1	6	Mul 9	1912	No picture	120t, 9.1kts; 20m

© Ivan Gogin, 2010-14

[home](#)

[World navies yesterday](#)

[1935](#)

Turkey 01 January 1935

CAPITAL SHIPS

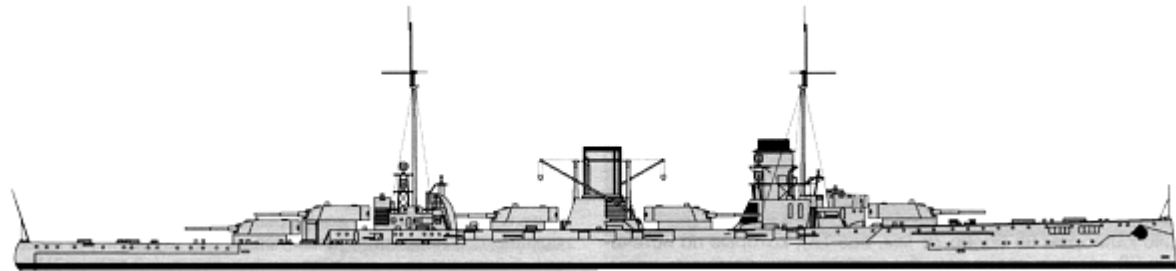
CB	Yavuz Sultan Selim	1	1	Yavuz Selim	1912		25300t, 186.6x29.5x8.7m, 24b,4t, 52000hp, 25.5kts, 1053p; 270belt, 50deck, 230turrets, 350CT; 5x2-283/47, 10x1-150/45, 6x1-88/45, 2-500TT
----	--------------------	---	---	-------------	------	--	---

CRUISERS

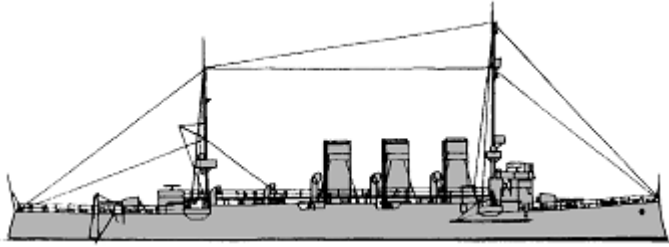
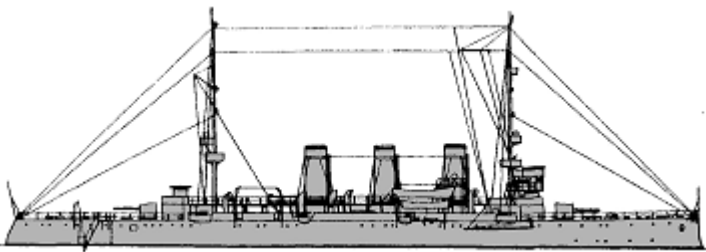

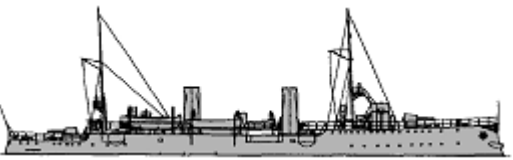
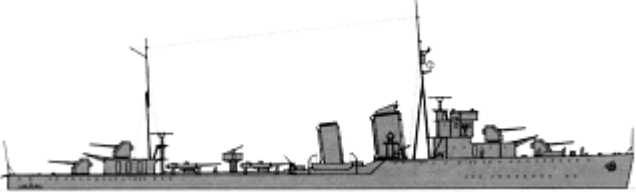
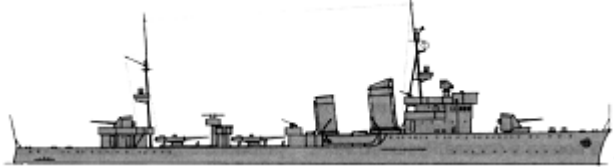

CL	Mecidiye	1	1	Mecidiye	1903		3967t, 102.4x12.8x4.8m, 16b,2vqe, 12500hp, 22kts, 312p; 38deck, 102slopes; 4x1-130/55, 4x1-76/50, 2-450TT
	Hamidiye	1	2	Hamidiye	1904		3904t, 112.0x14.5x4.88m, 6b,2vte, 12000hp, 22kts, 302p; 38deck, 102slopes; 2x1-150/45, 8x1-75/50, 2x1-450TT, 70m

TORPEDO SHIPS



PGT	Peyk-i Şevket	2	1	Peyk	1907		775t, 80.1ppx8.4x4.6m, 4b,2vte, 5100hp, 21kts, 105p; 2x1-105/40, 6x1-57/40, 2x1-37/50, (1+2x1)-450TT
-----	---------------	---	---	------	------	--	--

			2	Berk	1907		
DD	Kocatepe	2	1	Kocatepe	1931		1650t, 100.2x9.4x2.9m, 3b,2gt, 40000hp, 36kts, 149p; 4x1-120/50, 3x1-40/39, 2x3-533TT
			2	Adatepe	1931		
	Zafer	2	3	Zafer	1932		1610t, 96.0x9.3x3.3m, 3b,2gt, 35000hp, 36kts, 149p; 2x2-120/50, 2x1-40/39, 2x3-533TT
			4	Tinaztepe	1932		

SUBMARINES

SS	İnönü	2	1	Birinci İnönü	1928		519/674t, 58.7x5.8x3.8m, 2d/em, 1100/700hp, 13.5/8.5kts, 44p, 50m; 1x1-75/55, 6-450TT
			2	İkinci İnönü	1928		
	Dumlupınar	1	3	Dumlupınar	1931		1192/1726t, 74.1x7.8x4.4m, 2d/em, 2300/1400hp, 17.5/9kts, 47p, 100m; 1x1-100/43, 6-533TT, 48m
	Sakarya	1	4	Sakarya	1931		815/1145t, 61.6x6.7x4.3m, 2d/em, 1500/1100hp, 16.9/9.5kts, 41p, 100m; 1x1-100/43, 6-533TT
Gür	1	5	Gür	1934		755/965t, 72.4x6.4x4.2m, 2d/em, 2880/1000hp, 19.7/8.5kts, 42p, 100m; 1x1-105/45, 6-533TT	

COASTAL FORCES

PT	Doğan	3	1-3	Doğan, Denizkuşu, Martı	1931		32t, 21.0x4.2x1.0m, 3pe, 1500hp, 34kts, 10p; 1x1-75/55, 1x1-20/65, 2-450TR, 2DCR
YP	No1	5	1-5	No11, 15, 18, 21, Mülazim Hayati	1914		20t, 18.3ppx3.3x1.6m, 2pe(1), 70hp, 11.9kts, 6p; 1x1-37/37

MINE WARFARE SHIPS

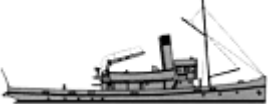
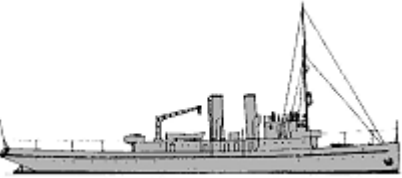
ML	Nusret	1	1	Nusret	1913		365t, 40.2ppx7.6x3.4m, 2b,2vte, 1200hp, 15kts; 2x1-57/40, 40m
AML	-	1	1	İntibah	1886		616brt; 1x1-75/35, 50m

MS	İsa Reis	3	1	İsa Reis	1914		413t, 47.0x7.9x1.3m, 3b,2vte, 850hp, 14kts, 60p; 2x1-75/50, 2x1-47/50, MS
			2	Kemal Reis	1914		
			3	Hizir Reis	1914		

© Ivan Gogin, 2011-15

[home](#)



[World navies yesterday](#)



[1935](#)

UNITED KINGDOM 01 January 1935

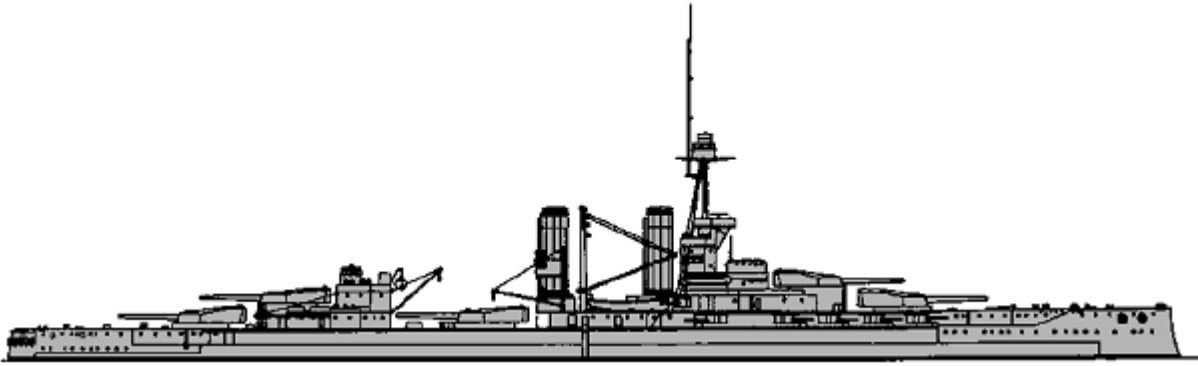
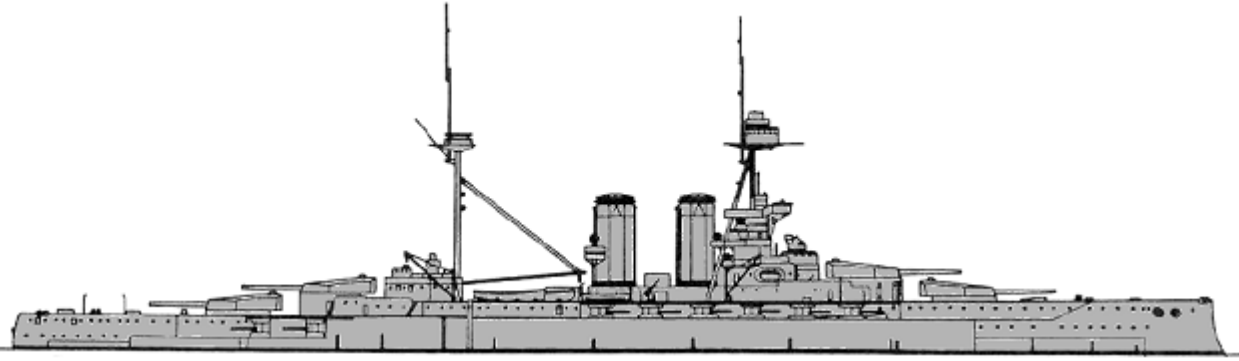
IN SERVICE: 13 battleships, 3 battlecruisers, 3 monitors, 4 fleet aircraft carriers, 2 light aircraft carriers, 1 seaplane tender, 17 heavy cruisers, 28 light cruisers, 1 cruiser-minelayer, 21 destroyer leaders, 132 destroyers, 55 submarines, 29 sloops, 5 patrol ships, 18 river gunboats, 9 motor torpedo boats, 17 small landing ships, 2 small landing barges, 2 landing crafts, 4 minelayers, 2 auxiliary minelayers, 1 netlayer, 29 minesweepers, 17 minesweeping trawlers, 23 minesweeping drifters

CAPITAL SHIPS AND MONITORS

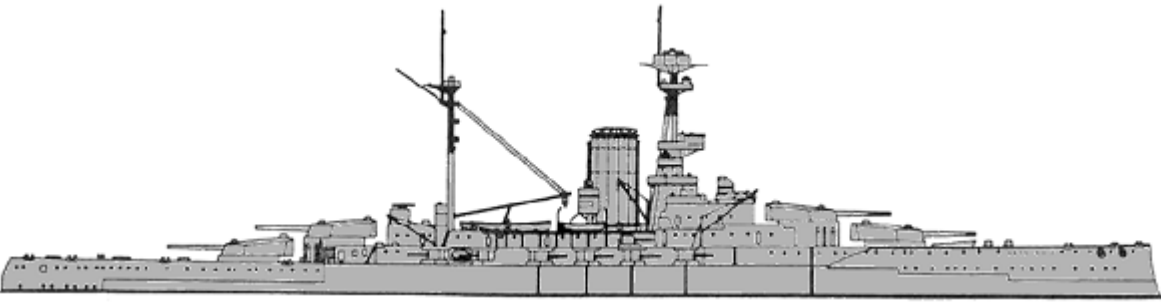
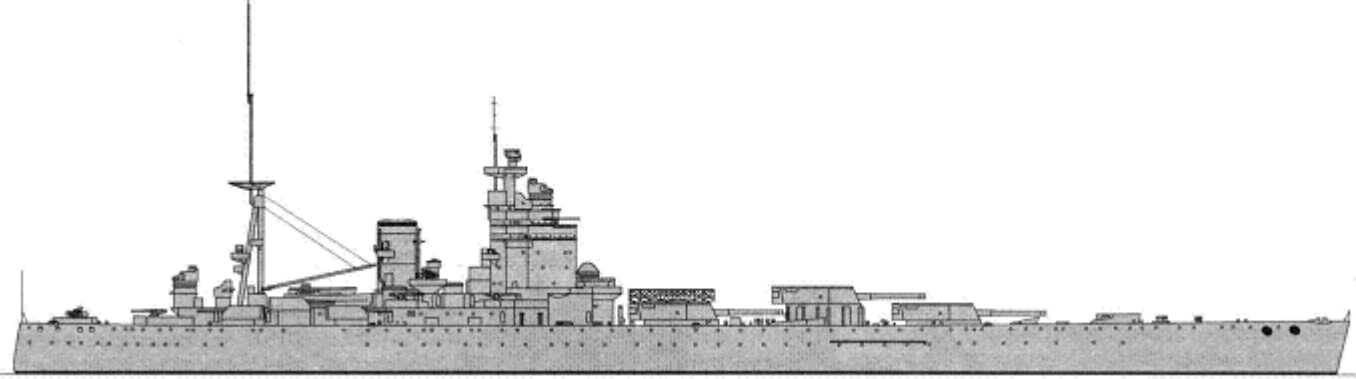
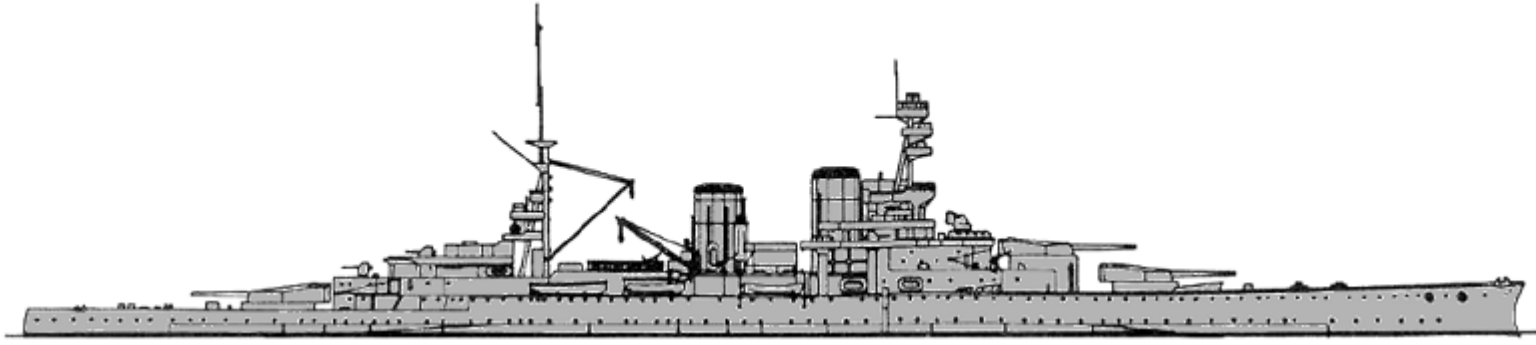
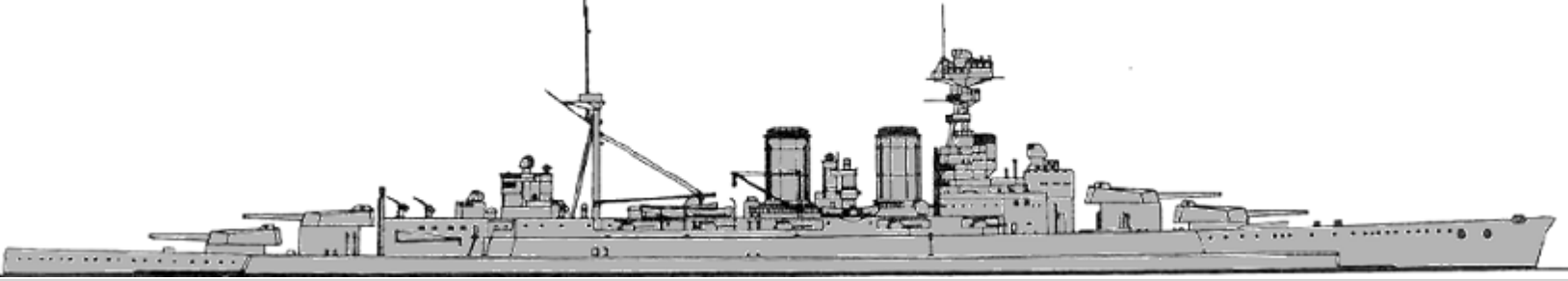
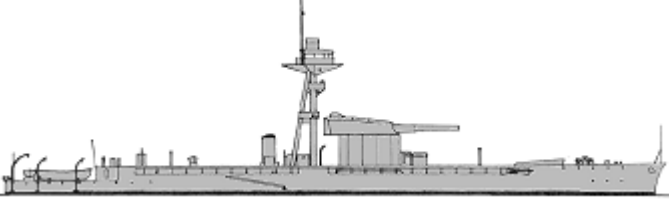
BB	Iron Duke	4	1	Iron Duke(TS)	1914		30380t, 189.8x27.4x9.0m, 12b, 4t, 18000hp, 18kts, 1022p; 280turrets, 89deck, 305CT; 3x2-343/45, 12x1-152/45, 2x1-76/45, 4x1-47/40, 4-533TT	
	Queen Elizabeth	5		2	Queen Elizabeth	1915		35710(2,3,5,6)-36785(4)t, 196.8x31.7x8.8m, 24boilers, 4turbines, 56000hp, 23.5(2,3,5,6)-23(4)kts, 951p; 330belt, 330turrets, 102(2,3,5,6)-127(4)deck, 280CT; 4x2-381/42, 12x1-152/45, 4x1-102/45, 4x1-47/40, 2x8-40/39(3), 1x8-40/39(5), 2x4-12.7(5), 2-533TT, 1seaplane(4,5, Osprey)
				3	Warspite	1915		
				4	Barham	1915		
				5	Valiant	1916		
				6	Malaya	1916		
	Revenge	5		7	Revenge	1916		32526(7,10)-32474(8)-32100(9)-33500(11)t, 190.3x30.9(7,10)-31.0(8)-31.1(9,11)x8.3(7,10)-8.7(8,9)-8.4(11)m, 18b, 4gt, 40000hp, 22(7-10)-21.5(11)kts, 997p; 330belt, 330turrets, 102deck, 280CT; 4x2-381/42, 12x1-152/45, 4x1-102/45(7-9,11), (1x2+3x1)-102/45(10), 4x1-47/40, 2x8-40/39,
				8	Royal Sovereign	1916		
				9	Royal Oak	1916		
				10	Resolution	1916		

						2x4-12.7, 2-533TT, 1seaplane(11, Osprey)
	Nelson	12	Nelson	1927		41250t, 216.4x32.3x10.2m, 8b, 2gt, 45000hp, 23kts, 1314p; 356belt, 406turrets, 159deck, 356CT; 3x3-406/45, 6x2-152/50, 6x1-120/40, 1x8-40/39, 4x1-47/40, 2-622TT
		13	Rodney	1927		
BC	Renown	1	Renown	1916		37150(1)-37490(2)t, 242.0x31.2(1)-30.8(2)x9.5(1)-9.6(2)m, 42b, 4t, 112000hp, 30kts, 967p; 229belt, 229turrets, 102(1)-76(2)deck, 254CT; 3x2-381/42, (4x3+4x1)-102/45(1), (5x3+4x1)-102/45(2), 2x8-40/39(1), 2x4-12.7(1), (4x2+2)-533TT(2), 2seaplanes(1, Osprey)
		2	Repulse	1916		
	Hood	1	3 Hood	1920		48000t, 262.1x31.7x8.7m, 24b, 4gt, 144000hp, 31kts, 1477p; 305belt, 381turrets, 76deck, 280CT; 4x2-381/42, 12x1-140/50, 4x1-102/45, 4x1-47/40, 2x8-40/39, 2x4-12.7, 6-533TT
MON	Marshal Ney	1	1 Marshal Soult	1915		6900t, 108.4x27.5x3.2m, 2diesels, 1500hp, 6kts, 187p; 102belt, 330turret, 102deck, 152CT; 1x2-381/42, 8x1-102/45, 2x1-76/50, 1x1-76/45, 1x1-47/50, 2x1-40/39
	Erebus	2	Erebus	1916		8450t, 123.4x26.9x3.6m, 4b, 2vte, 6000hp, 12kts, 204p; 102belt, 330turret, 102deck; 1x2-381/42, 8x1-102/45, 2x1-76/45, 2x1- 76/40, 2x1-40/39
3		Terror	1916			

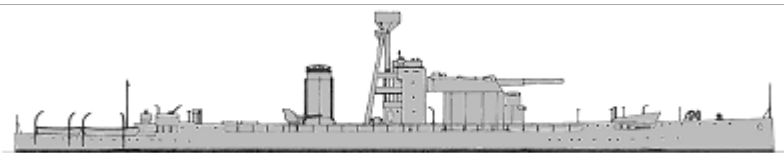

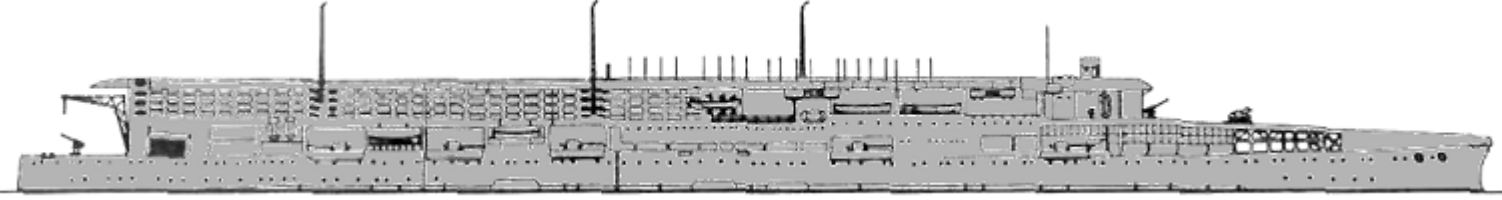
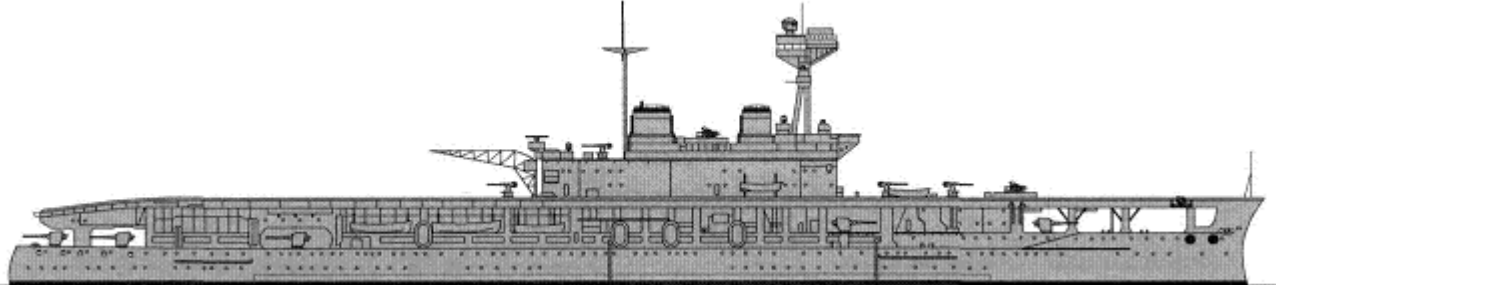
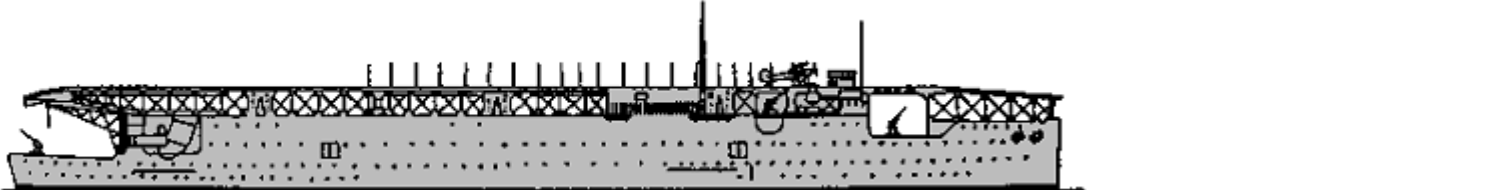
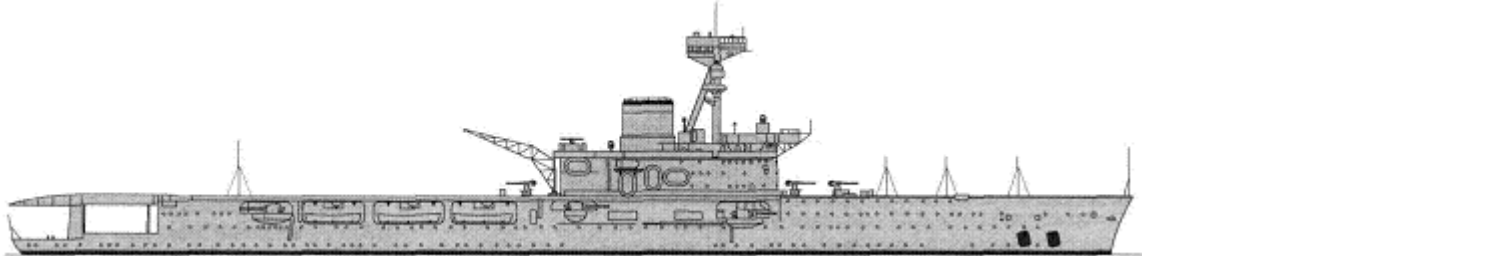

AIRCRAFT CARRYING SHIPS

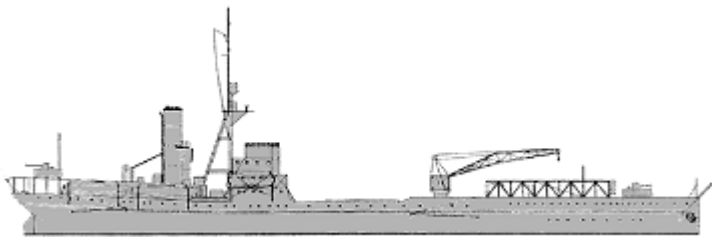
	Furious	1	1	Furious	1917	 <p>27165t, 239.7x27.9x8.6m, 18b, 4gt, 90000hp, 30kts, 1218p; 76belt, 76deck; 10x1-140/50, 3x1-102/45, 4x1-47/40, 2x8-40/39, 36aircraft (3 Osprey, 9 Nimrod, 12 Baffin, 12 Fairey IIIIF)</p>
CV	Eagle	1	2	Eagle	1923	 <p>26800t, 203.5x32.0x8.1m, 32b, 4gt, 50000hp, 22.5kts, 950p; 114belt, 76shields, 38deck; 9x1-152/50, 4x1-102/45, 1x8-40/39, 2x4-12.7, 25aircraft (9 Osprey, 12 Fairey IIIIF)</p>
			3	Courageous	1917	<p>27560(3)-27400(4)t, 239.8x27.9x8.5m, 18b, 4gt, 90000hp, 1216p; 76belt, 76deck; 16x1-120/40, 4x1-47/40, 2x8-40/39(3), 3x8-40/39(4), 48 aircraft ((9 Nimrod, 3 Osprey, 12 Shark, 12 Baffin, 12 Seal)(3) or (8 Nimrod, 8 Osprey, 12 Baffin, 18 Fairey IIIIF, 6 Seal)(4))</p>
	Courageous	2	4	Glorious	1917	
	Argus	1	1	Argus	1918	 <p>15750t, 172.5x24.2x6.4m, 12b, 4gt, 20000hp, 20kts, 401p; 51magazines; 6x1-102/45, 20aircraft (4 Osprey, 12 Fairey IIIIF)</p>
CVL	Hermes	1	2	Hermes	1924	 <p>13700t, 182.3x21.4x5.7m, 6b, 2gt, 40000hp, 25kts, 664p; 76belt, 25deck; 6x1-140/50, 2x1-102/45, 2x4-12.7, 20aircraft (6 Osprey, 9 Seal)</p>

AV	Ark Royal	1	1	Ark Royal	1914		7400t, 111.6x15.5x5.5m, 2b, 1vte., 3000hp, 11kts, 180p; 4x1-76/50, 7aircraft (really none)
----	-----------	---	---	-----------	------	---	--

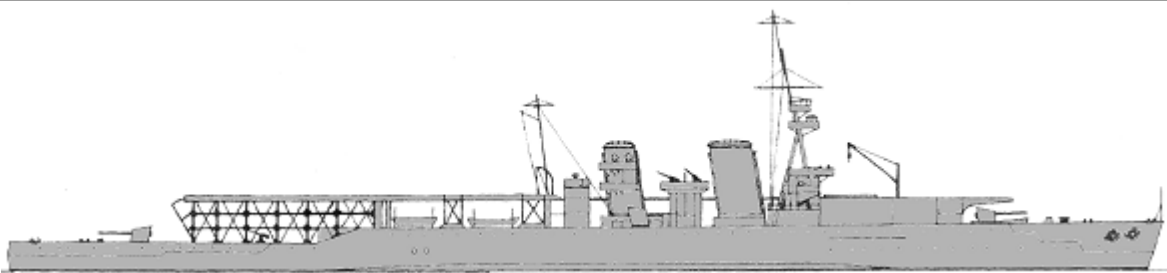
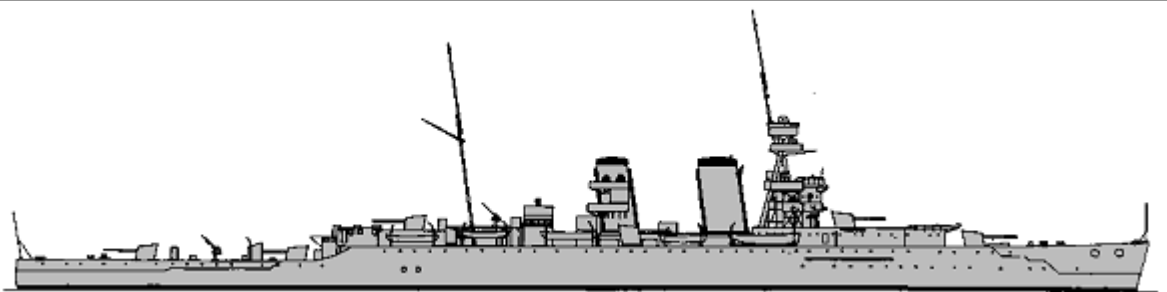
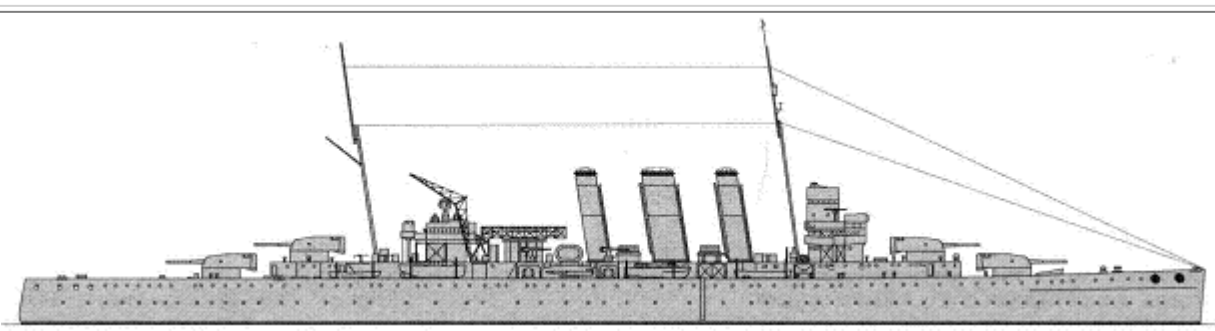
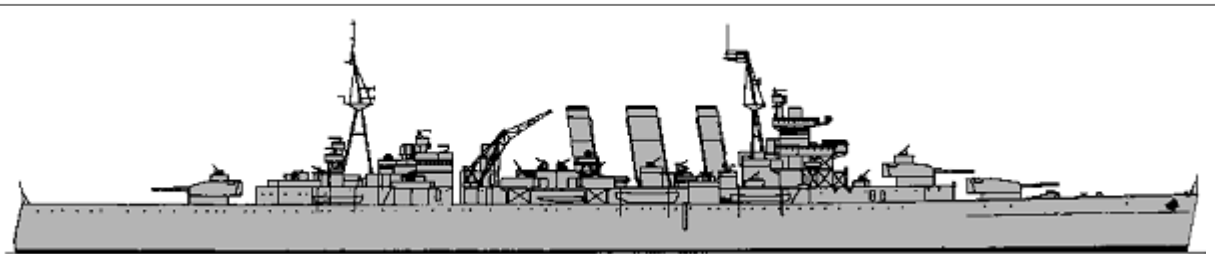
CRUISERS

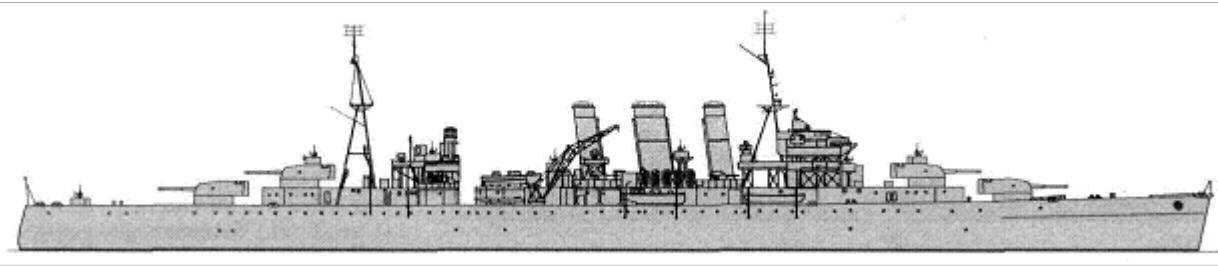
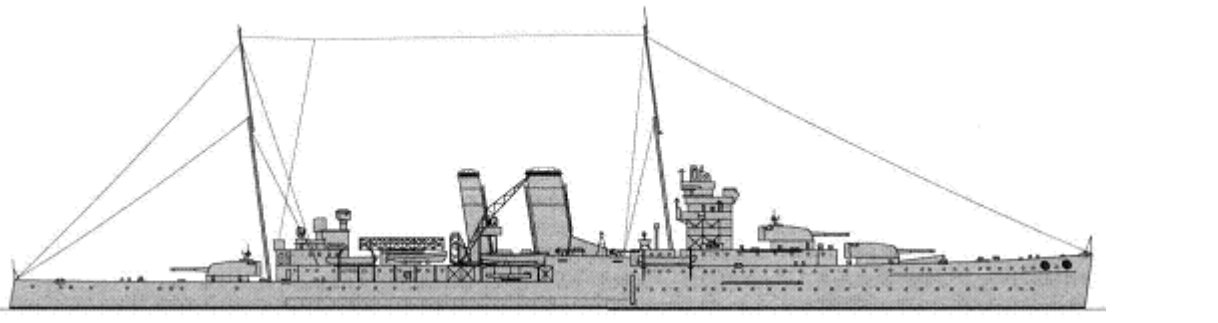
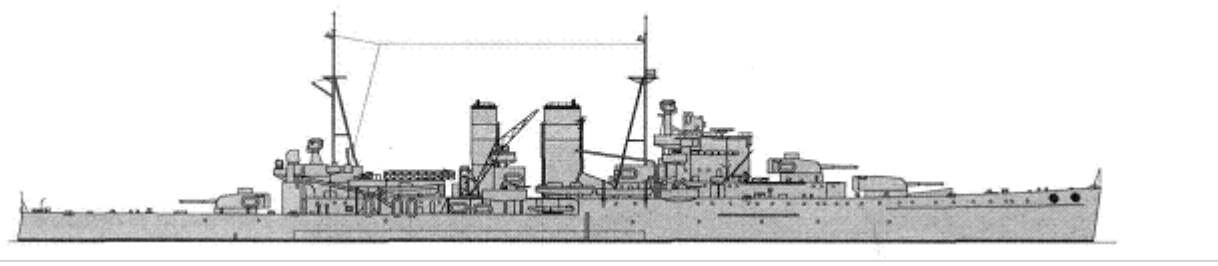
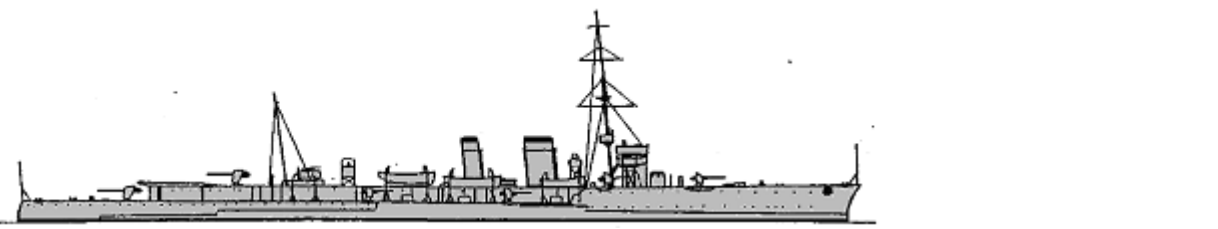
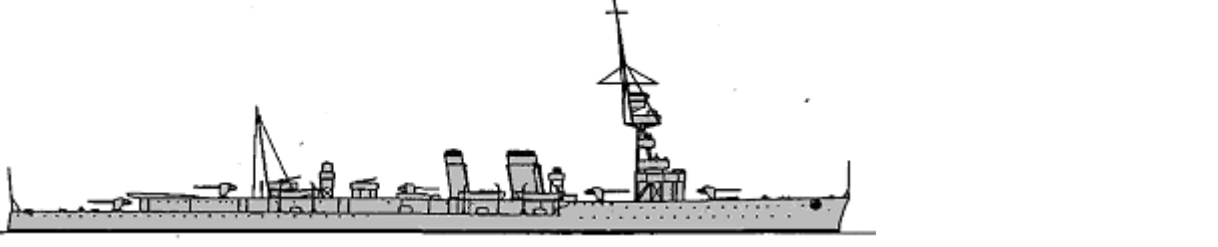
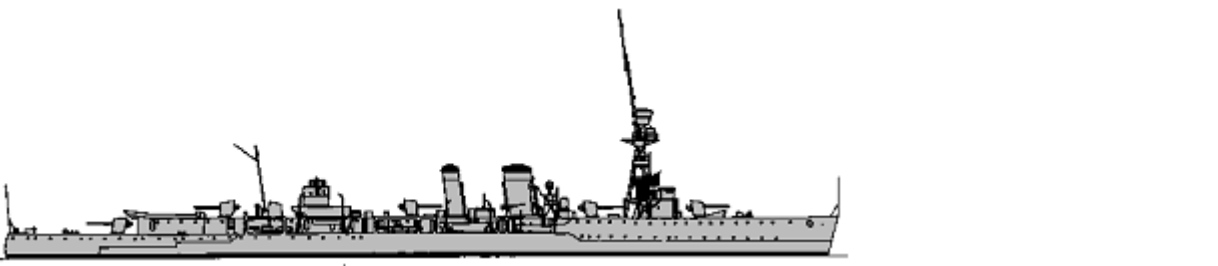

CA	Vindictive	1	1	Vindictive	1918		12000t, 184.4x19.8x5.9m, 12b, 4gt, 60000hp, 30kts, 560p; 76belt, 38deck, 76CT; 6x1-190/45, 3x1-102/45, 4x1-47/40, 1x1-40/39, 6-533TT
	Hawkins	2	Hawkins	1919		12300t, 184.4x19.8x5.9m, 8(2)-10(3, 4)b, 4gt, 55000(2)-65000(3, 4)hp, 29.5(2)-30.5(3, 4)kts, 712p; 76belt, 51gunhouses, 38deck, 76CT; 7x1-190/45(2,4), 5x1-190/45(3), 4x1-102/45(2, 3), 3x1-102/45(4), 4x1-47/40(2), 2x1-40/39, 6-533TT(2,4), 2-533TT(3), 1seaplane(3) (1 Fairey III F)	
		3	Frobisher	1924			
		4	Effingham	1925			
	Kent	5	Cumberland	1928		13400-13540t, 192.0-192.9x20.8x6.3m, 8b, 4gt, 80000hp, 31.5kts, 710p; 25belt, 111magazines, 38deck, 25turrets; 4x2-203/50, 4x1-102/45(5-8), 6x1-102/45(9), 4x1-47/40, 4x1-40/39, 2x4-12.7, 2x4-533TT, 1seaplane(Osprey)	
		6	Berwick	1928			
		7	Cornwall	1928			
		8	Suffolk	1928			
		9	Kent	1928			
	London	10	London	1929		13315t, 192.0-192.9x20.1x6.3m, 8b, 4gt, 80000hp, 32.3kts, 700p; 25belt, 102magazines, 25turrets, 38deck; 4x2-203/50, 4x1-102/45, 4x1-47/40, 4x1-40/39, 1x4-40/39(13), 2x4-533TT, 1seaplane(Osprey)	
		11	Devonshire	1929			
		12	Sussex	1929			
		13	Shropshire	1929			
	Norfolk	14	Dorsetshire	1930		13425t, 193.7x20.1x6.4m, 8b, 4gt, 80000hp, 32.3kts, 710p; 25belt, 38deck, 25turrets; 4x2-203/50, 4x1-102/45, 4x1-47/40, 4x1-40/39, 2x4-12.7, 2x4-533TT, 1seaplane(Osprey)	
		15	Norfolk	1930			

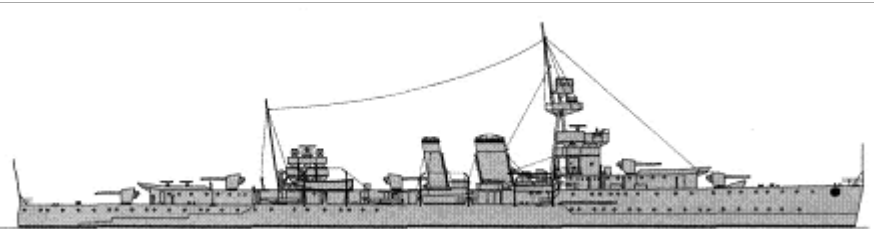
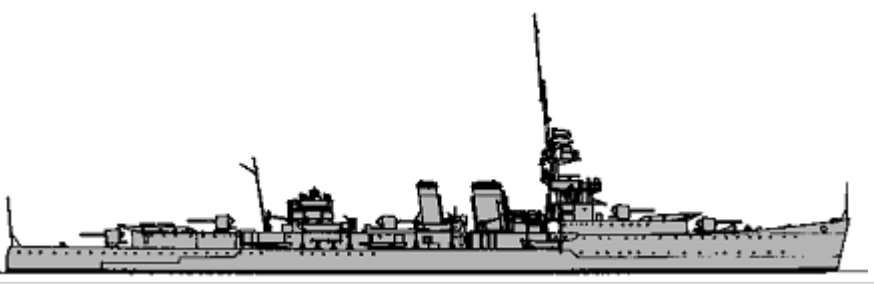
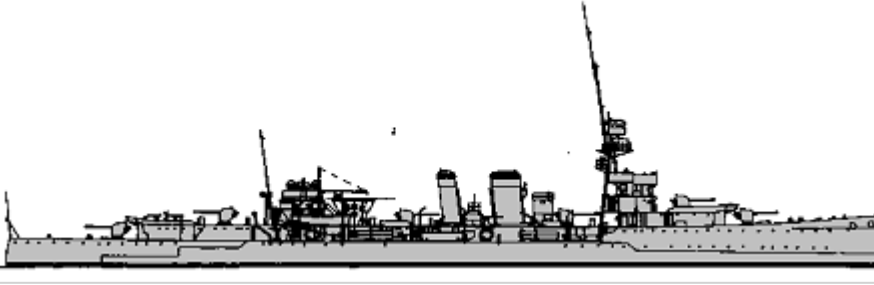
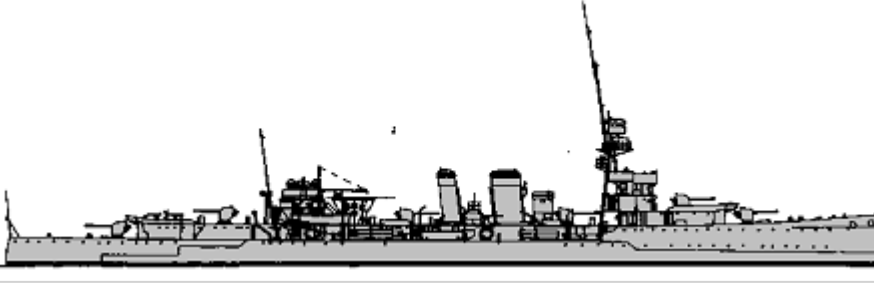
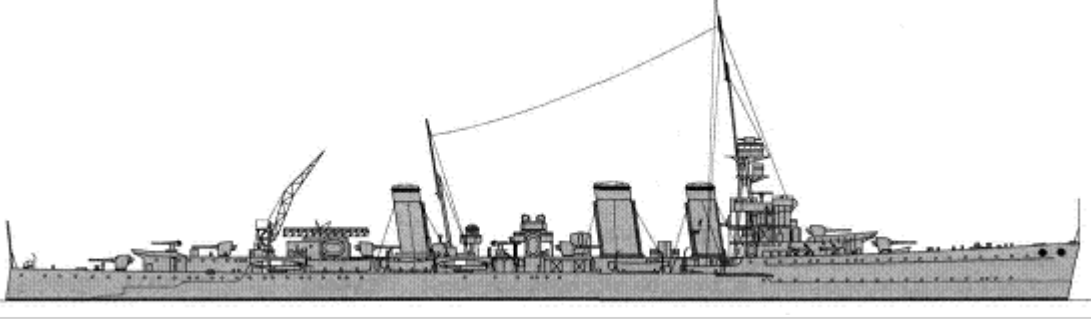
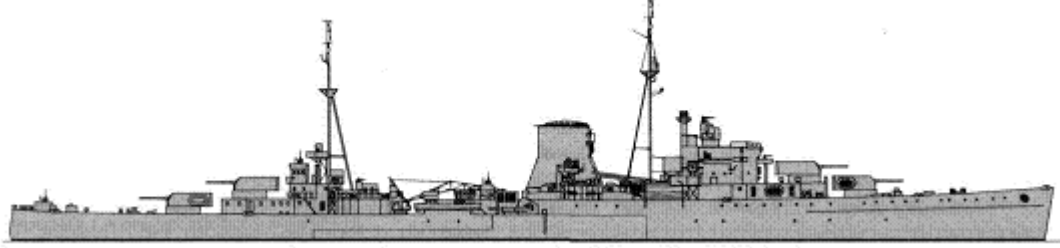

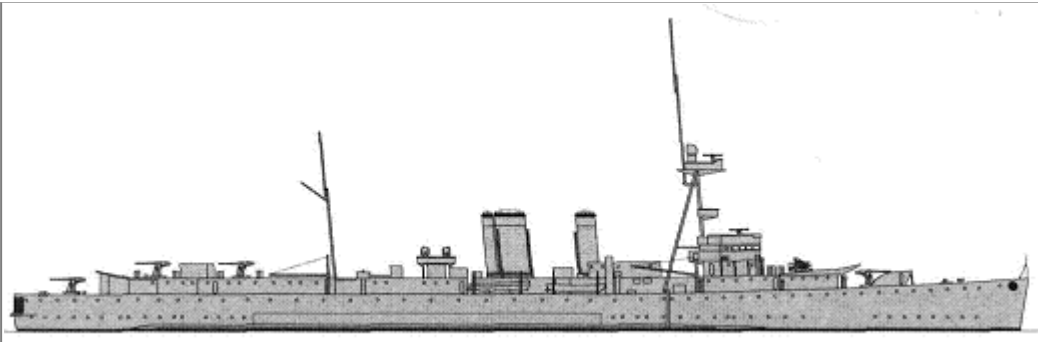
						
York	1	16	York	1930		10350t, 175.3x17.4x6.2m, 8b, 4gt, 80000hp, 32.3kts, 623p; 76belt, 38deck, 25turrets; 3x2-203/50, 4x1-102/45, 4x1-47/40, 2x3-533TT, 1seaplane(Fairey IIIIF)
Exeter	1	17	Exeter	1931		10490t, 175.3x17.7x6.2m, 8b, 4gt, 80000hp, 32kts, 630p; 76belt, 38deck, 25turrets; 3x2-203/50, 4x1-102/45, 4x1-47/40, 2x3-533TT, 2seaplanes(Fairey IIIIF)
Cambrian	1		Castor	1915		4799t, 135.9x12.6x4.5m, 6b, 4gt, 40000hp, 28.5kts, 368p; 76belt, 102shields, 25deck, 152CT; 4x1-152/45, 2x1-76/45, 4x1-47/40, 2x1-40/39(1), 2-533TT
	2		Constance	1916		
Centaur	1	3	Concord	1916		4870t, 135.9x12.8x4.1m, 6b, 4gt, 40000hp, 29kts, 437p; 76belt, 102shields, 25deck, 152CT; 4x1-152/45, 2x1-40/39, 2-533TT
Caledon	4		Caledon	1917		4950t, 137.2x13.0x5.0m, 6b, 2gt, 40000hp, 29kts, 400p; 76belt, 25shields, 25deck; 5x1-152/45, 2x1-76/45, 4x1-47/40, 2x1-40/39, 4x2-533TT
	5		Calypso	1917		
	6		Caradoc	1917		
Ceres	7		Cardiff	1917		5020t, 137.2x13.3x4.5m, 6b, 2gt, 40000hp, 29kts, 460p; 76belt, 25shields, 25deck; 5x1-152/45,
	8		Ceres	1917		
	9		Curlew	1917		

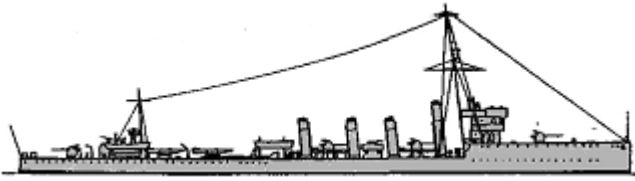

CL										
		10	Coventry	1918		2x1-76/45, 4x1-47/40, 2x1-40/39, 4x2-533TT				
		11	Curacoa	1918						
	Carlisle	5	12	Carlisle	1918		5250t, 137.6x13.3x4.7m, 6b, 2gt, 40000hp, 29kts, 432p; 76belt, 25shields, 25deck; 5x1-152/45, 2x1-76/45, 4x1-47/40, 2x1-40/39, 4x2-533TT			
			13	Cairo	1919					
			14	Calcutta	1919					
			15	Colombo	1919					
			16	Capetown	1922					
	Danae	3	17	Danae	1918		5870t, 143.6x13.9x5.0m, 6b, 2gt, 40000hp, 29kts, 450p; 76belt, 25shields, 25deck, 76CT; 6x1-152/45, 3x1-102/45, 2x1-40/39, 4x3-533TT			
			18	Dauntless	1918					
19			Dragon	1918						
Delhi	3	20	Delhi	1919		5870t, 143.6x13.9x5.0m, 6b, 2gt, 40000hp, 29kts, 450p; 76belt, 25shields, 25deck, 76CT; 6x1-152/45, 3x1-102/45, 2x1-40/39, 4x3-533TT				
		21	Durban	1921						
		22	Despatch	1922						
Emerald	2	23	Emerald	1926		9450t, 173.7x16.6x5.6m, 8b, 4gt, 80000hp, 33kts, 450p; 76belt, 25turret/shields, 25deck, 76CT; 7x1-152/45(23), (1x2+5x1)-152/45(24), 3x1-102/45, 4x1-47/40, 2x1-40/39, 4x4-533TT, 1seaplane(23, Osprey)				
		24	Enterprise	1926						
Leander	4	25	Leander	1933		9280t, 169.0x16.8(25)-17.0(26-28)x6.0m, 6b,4gt, 72000hp, 32.5kts, 570p; 89magazines, 76belt, 51deck, 25turrets; 4x2-152/50, 4x1-102/45, 4x1-47/40, 3x4-12.7, 2x4-533TT, 2seaplanes(Osprey)				
		26	Achilles	1933						
		27	Neptune	1934						
		28	Orion	1934						

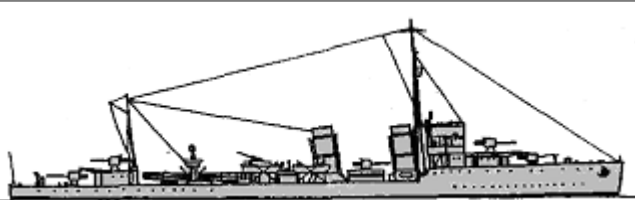
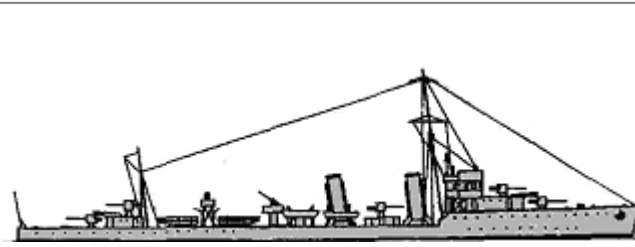
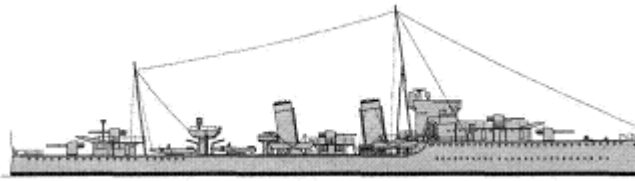
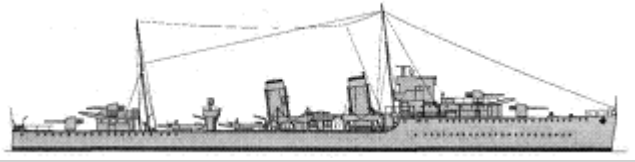
CM	Adventure	1	1	Adventure	1927		8370t, 164.3x18.0x5.2m, 6b, 2gt/4dg, 4em(2), 40000/8000hp, 28kts, 395p; 25belt, 25deck; 4x1-120/40, 4x1-47/40, 4x1-40/39, 2x4-12.7, 280mines
----	-----------	---	---	-----------	------	---	--

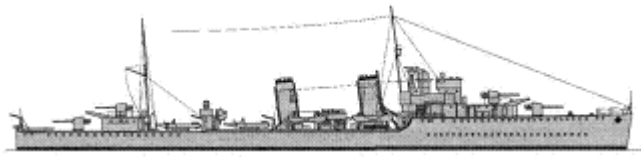
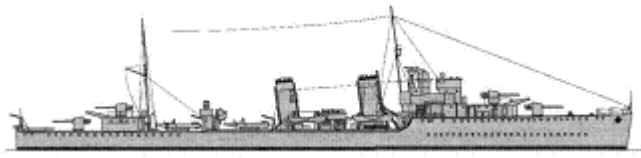
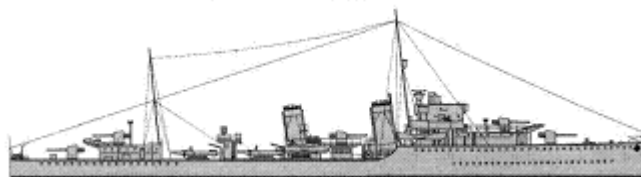
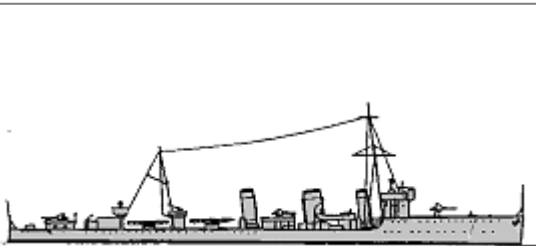
TORPEDO SHIPS

DL	Lightfoot	1	1	Abdiel	1916		1700t, 99.0x9.7x3.7m, 4b, 3t, 36000hp, 34.5kts, 104p; 2x1-102/40, 2x1-40/39, 80mines
	V	3	2	Valentine	1917		1400t, 95.1x9.0x3.2m, 3b, 2gt, 27000hp, 34kts, 115p; 4x1-102/45, 2x1-40/39, 2x3-533TT, 1DCR
			3	Valorous	1917		
			4	Valkyrie	1917		
	Shakespeare	5	5	Shakespeare	1917		2000t, 100.3x9.6x3.8m, 4b, 2gt, 40000hp, 36kts, 183p; 5x1-120/45, 1x1-76/45, 2x3-533TT, 2DCT, 1DCR
			6	Spencer	1917		
			7	Wallace	1919		
			8	Keppel	1924		
			9	Broke	1925		
	Scott	7	10	Bruce	1918		2050t, 101.3x9.7x3.8m, 4b, 2gt, 40000hp, 36kts, 164p; 5x1-120/45, 1x1-76/45, 2x3-533TT, 2DCT, 1DCR
			11	Douglas	1918		
			12	Campbell	1918		
			13	Stuart	1918		
			14	Montrose	1918		
			15	Malcolm	1919		
			16	Mackay	1919		
A	1	17	Codrington	1930		2012t, 104.5x10.3x3.8m, 3b,2gt, 39000hp, 35kts, 185p; 5x1-120/45, 2x1-40/39, 2x4-533TT, 3DCR	
B	1	18	Keith	1931		1821t, 98.5x9.8x3.7m, 3b,2gt, 34000hp, 35.2kts, 175p; 4x1-120/45, 2x1-40/39, 2x4-533TT, 2DCT, 1DCR	

C	1	19	Kempenfelt	1931		1942t, 100.3x10.1x3.8m, 3b,2gt, 36000hp, 36kts, 175p; 4x1-120/45, 1x1-76/45, 2x1-40/39, 2x4-533TT
D	1	20	Duncan	1933		1942t, 100.3x10.1x3.8m, 3b,2gt, 36000hp, 36kts, 175p; 4x1-120/45, 1x1-76/45, 2x1-40/39, 2x4-533TT, 2DCT, 1DCR
E	1	21	Exmouth	1934		2009t, 104.5x10.3x3.8m, 3b,2gt, 38000hp, 36.7kts, 175p; 5x1-120/45, 2x4-12.7, 2x4-533TT, 2DCT, 1DCR
R-Admiralty	8	1	Rowena	1916		1200-1244t, 84.1x8.1x2.7m, 3b, 2gt, 27000hp, 36kts, 82p; 3x1-102/40, 1x1-40/39, 2x2-533TT
		2	Restless	1916		
		3	Sable	1916		
		4	Skate	1917		
		5	Tempest	1917		
		6	Thisbe	1917		
		7	Thruster	1917		
		8	Torrid	1917		
R-Yarrow	1	9	Tyrant	1917		1051t, 83.4x7.8x2.7m, 3b, 2t, 27000hp, 36kts, 82p; 3x1-102/40, 1x1-40/39, 2x2-533TT
V-Admiralty	19	10	Vanquisher	1917		1480-1523t, 95.1x9.0x3.2m, 3b, 2gt, 27000hp, 34kts, 134p; 4x1-102/45 (can be 3x1-102/45 on 10,11,13,17,23,24,28), 1x1-40/39, 2x3-533TT(12,14-16,18-22,25-27), (1x3+1x2)-533TT(10,11,13,17,23,24,28) (can be 1x2-533TT on 10,11,13,17,23,24,28), 2DCT (or can be not on 10,11,13,17,23,24,28), 1DCR, MS, (can be 60mines on 10,11,13,17,23,24,28)
		11	Vanoc	1917		
		12	Vega	1917		
		13	Venturous	1917		
		14	Venetia	1917		
		15	Verdun	1917		
		16	Violent	1917		
		17	Vimiera	1917		
		18	Vivacious	1917		
		19	Vectis	1917		
		20	Vimy	1918		
		21	Vanessa	1918		
		22	Vanity	1918		
		23	Velox	1918		
24	Versatile	1918				
		25	Vesper	1918		

		26	Vidette	1918		
		27	Vivien	1918		
		28	Vortigern	1918		
V-Thornycroft	2	29	Viceroy	1918		1512t, 95.1x9.4x2.9m, 3b, 2gt, 27000hp, 34kts, 134p; 4x1-102/45, 1x1-40/39, 2x3-533TT, 2DCT, 1DCR, MS
		30	Viscount	1918		
W-Admiralty	17	31	Wakeful	1917		1490t, 95.1x9.0x3.2m, 3b, 2gt, 27000hp, 34kts, 134p; 4x1-102/45 (can be 3x1-102/45 on 32,35,37,39,41), 1x1-40/39, 2x3-533TT (can be 1x3-533TT on 32,35,37,39,41), 2DCT, 1DCR, MS, (can be 60mines on 32,35,37,39,41)
		32	Watchman	1918		
		33	Walpole	1918		
		34	Whitley	1918		
		35	Walker	1918		
		36	Westcott	1918		
		37	Walrus	1918		
		38	Wolfhound	1918		
		39	Warwick	1918		
		40	Wessex	1918		
		41	Whirlwind	1918		
		42	Wrestler	1918		
		43	Winchelsea	1918		
		44	Winchester	1918		
		45	Westminster	1918		
		46	Windsor	1918		
		47	Wryneck	1918		
W-Thornycroft	2	48	Woolsey	1918		1512t, 95.1x9.4x2.9m, 3b, 2gt, 27000hp, 34kts, 134p; 4x1-102/45, 1x1-40/39, 2x3-533TT, 2DCT, 1DCR, MS
		49	Woolston	1918		
S-Admiralty	28	50	Scimitar	1918		1225t, 84.1x8.1x2.7m, 3b, 2gt, 27000hp, 36kts, 90p; 3x1-102/40, 1x1-40/39, 2x2-533TT, 2DCT, 1DCR
		51	Scotsman	1918		
		52	Scout	1918		
		54	Sabre	1918		
		59	Senator	1918		
		60	Swallow	1918		
		61	Seafire	1918		
		62	Searcher	1918		
		63	Sportive	1918		
		64	Trojan	1918		
		65	Saladin	1919		
		66	Shamrock	1919		
		67	Sardonyx	1919		

DD

68	Spindrift	1919
69	Serene	1919
70	Stronghold	1919
71	Sturdy	1919
72	Trusty	1919
73	Turbulent	1919
74	Tenedos	1919
75	Thanet	1919
76	Thracian	1922
77	Shikari	1924

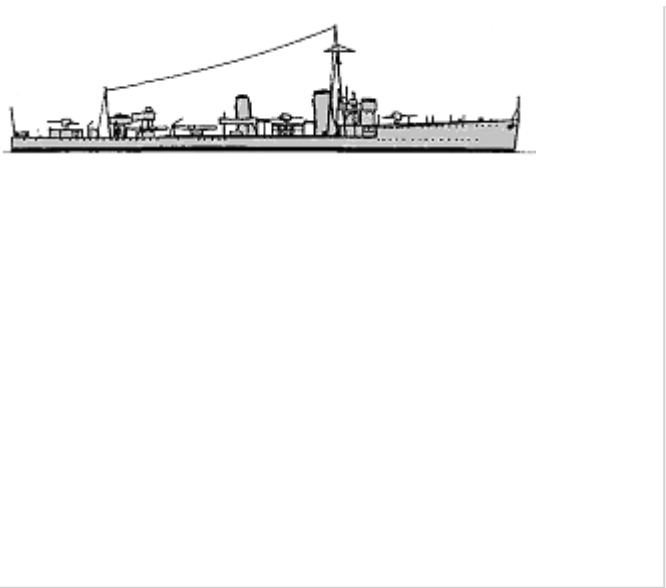

Modified W-Admiralty

14	78	Vansittart	1919
	79	Volunteer	1919
	80	Venomous	1919
	81	Verity	1919
	82	Wanderer	1919
	83	Veteran	1919
	84	Whitshed	1919
	85	Wild Swan	1919
	86	Witherington	1919
	87	Wivern	1919
	88	Wolverine	1920
	89	Worcester	1922
	90	Wren	1923
	91	Whitehall	1924

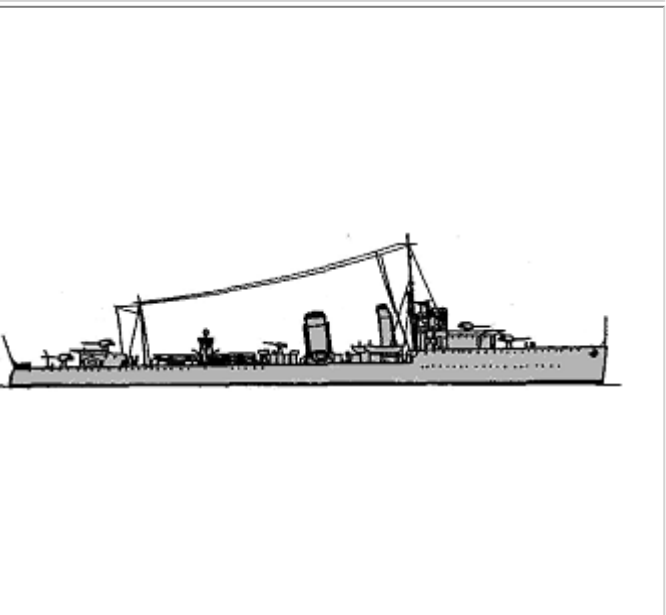

1508t, 95.1x9.0x3.2m, 3b, 2gt, 27000hp, 34kts, 127p; 4x1-120/45, 2x1-40/39, 2x3-533TT, 2DCT, 1DCR

Modified W-Thornycroft

2	92	Wishart	1920
	93	Witch	1924

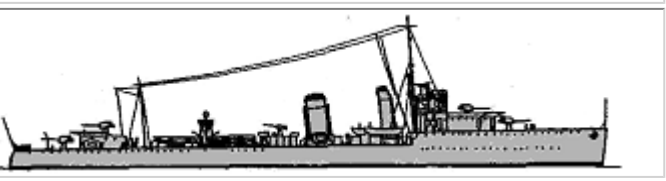

1530t, 95.1x9.4x2.9m, 3b, 2gt, 30000hp, 35kts, 127p; 4x1-120/45, 2x1-40/39, 2x3-533TT, 2DCT, 1DCR

Amazon

1	94	Amazon	1926
---	----	--------	------

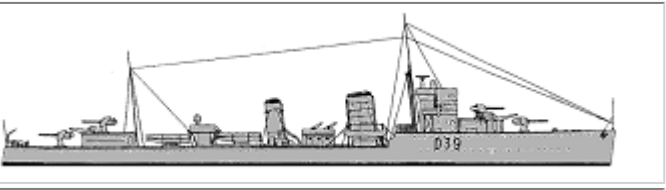

1812t, 98.5x9.6x3.8m, 3b, 2gt, 39500hp, 37kts, 138p; 4x1-120/45, 2x1-40/39, 2x3-533TT

Ambuscade

1	95	Ambuscade	1927
---	----	-----------	------

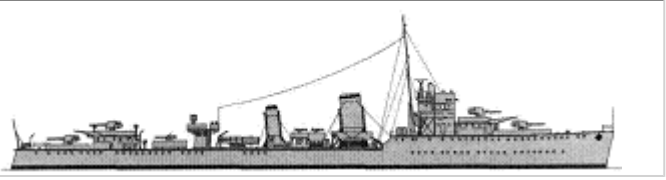





1585t, 98.1x9.5x3.5m, 3b, 2gt, 33000hp, 37kts, 138p; 4x1-120/45, 2x1-40/39, 2x3-533TT

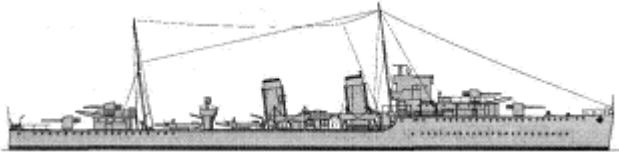
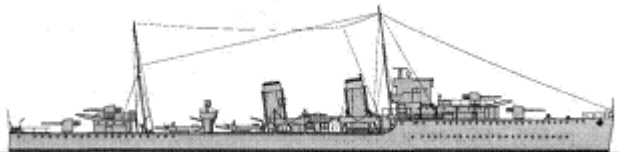
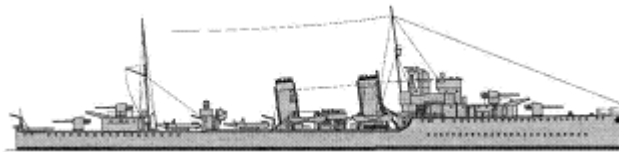
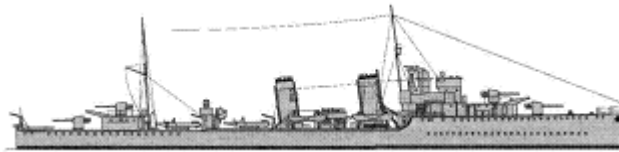
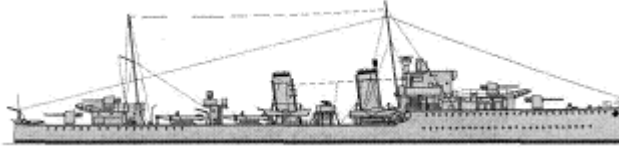
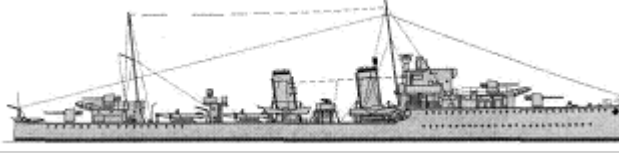



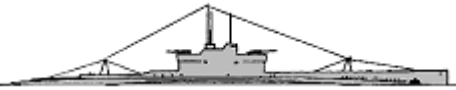
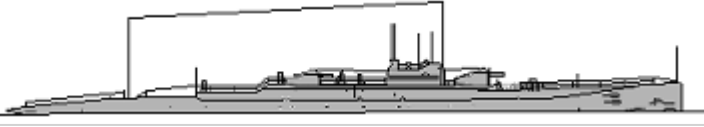

	96	Acasta	1930
--	----	--------	------

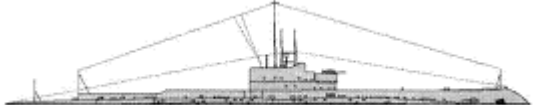

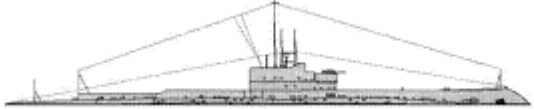
A	8	97	Achates	1930		1747t, 98.5x9.8x3.7m, 3b,2gt, 34000hp, 35.2kts, 138p; 4x1-120/45, 2x1-40/39, 2x4-533TT, 3DCR, MS
		98	Active	1930		
		99	Antelope	1930		
		100	Anthony	1930		
		101	Ardent	1930		
		102	Arrow	1930		
		103	Acheron	1931		
B	8	104	Basilisk	1931		1815t, 98.5x9.8x3.7m, 3b,2gt, 34000hp, 35.2kts, 138p; 4x1-120/45, 2x1-40/39, 2x4-533TT, 2DCT, 1DCR
		105	Beagle	1931		
		106	Blanche	1931		
		107	Boadicea	1931		
		108	Boreas	1931		
		109	Brazen	1931		
		110	Brilliant	1931		
111	Bulldog	1931				
C	4	112	Comet	1932		1865t, 100.3x10.1x3.8m, 3b,2gt, 36000hp, 36kts, 145p; 4x1-120/45, 1x1-76/45, 2x1-40/39, 2x4-533TT, 3DCR, MS
		113	Crescent	1932		
		114	Crusader	1932		
		115	Cygnets	1932		
D	8	116	Daring	1932		1942t, 100.3x10.1x3.8m, 3b,2gt, 36000hp, 36kts, 145p; 4x1-120/45, 1x1-76/45, 2x1-40/39(116-119), 2x4-12.7(120-123), 2x4-533TT, 2DCT, 1DCR
		117	Defender	1932		
		118	Diamond	1932		
		119	Diana	1932		
		120	Dainty	1933		
		121	Decoy	1933		
		122	Delight	1933		
123	Duchess	1933				
E	8	124	Echo	1934		1886t, 100.3x10.1x3.8m, 3b,2gt, 36000hp, 36kts, 145p; 4x1-120/45, 2x4-12.7, 2x4-533TT, 2DCT(124-129), 1DCR(124-129), 72m(130,131)
		125	Eclipse	1934		
		126	Electra	1934		
		127	Encounter	1934		
		128	Escapade	1934		
		129	Escort	1934		
		130	Esk	1934		
131	Express	1934				
F	1	132	Fearless	1934		1940t, 100.3x10.1x3.8m, 3b,2gt, 36000hp, 36kts, 145p; 4x1-120/45, 2x4-12.7, 2x4-533TT, 2DCT, 1DCR

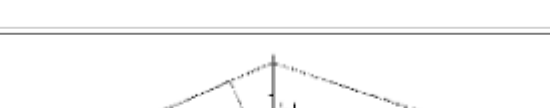
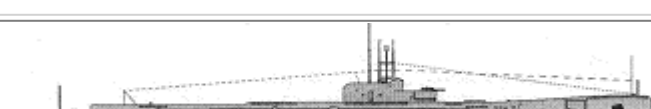

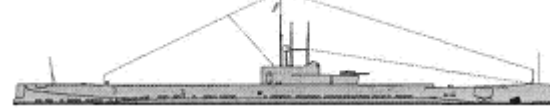

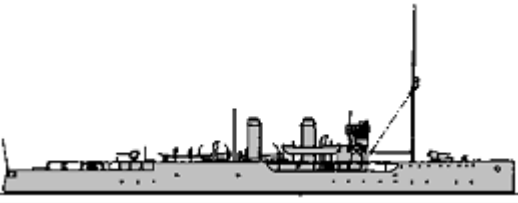
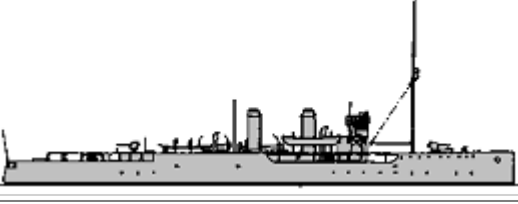

SUBMARINES

SS	L-I	1	1	L6	1918		891/1074t, 70.4x7.2x4.0m, 2d/em, 2400/1600hp, 17/10.5kts, 35p, 50m; 1x1-102/40, 6-450TT
	H-II	12	2	H27	1918		423/510t, 52.4x4.8x4.0m, 2d/em, 480/620hp, 11.5/10.5kts, 22p, 30m; 4-533TT
			3	H28	1918		
			4	H30	1918		
			5	H31	1919		
			6	H32	1919		
			7	H33	1919		
			8	H34	1919		
			9	H43	1919		
			10	H48	1919		
			11	H49	1919		
			12	H44	1920		
			13	H50	1920		
L-II	9	14	L18	1919		890/1080t, 72.7x7.2x4.0m, 2d/em, 2400/1600hp, 17/10.5kts, 38p, 50m; 1x1-102/40, 4-533TT, 2-450TT(14-17,19-22), 14mines(18)	
		15	L19	1919			
		16	L20	1919			
		17	L21	1920			
		18	L25	1920			
		19	L22	1921			
		20	L23	1924			
		21	L26	1926			
		22	L27	1926			
L-III	6	23	L56	1919		960/1150t, 71.6x7.2x4.0m, 2d/em, 2400/1600hp, 17/10.5kts, 44p, 50m; 2x1-102/40(25), 1x1-102/40(23, 24, 26-28), 6-533TT	
		24	L71	1920			
		25	L52	1921			
		26	L69	1923			
		27	L54	1924			
		28	L53	1925			
X	1	29	X1	1925		2780/3600t, 110.8x9.1x4.8m, 2d+2dg/2em, 7000/2400hp, 19.5/8kts, 110p, 60m; 2x2-132/42, 6-533TT	
Oberon	1	30	Oberon	1927		1598/1831t, 82.2x8.5x4.7m, 2d/em, 2950/1350hp, 13.7/7.5kts, 54p, 60m; 1x1-102/40, 8-533TT	
Oxley	2	31	Oxley	1927		1636/1872t, 83.8x8.4x4.8m, 2d/em, 3100/1350hp, 15/8.5kts, 55p, 60m; 1x1-102/40, 8-533TT	
		32	Otway	1927			

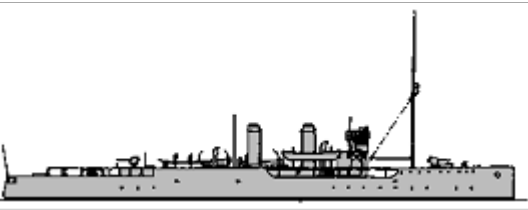

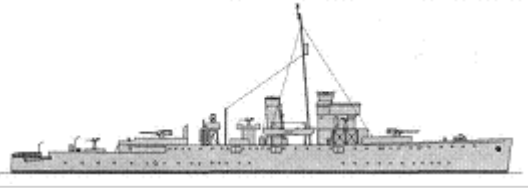
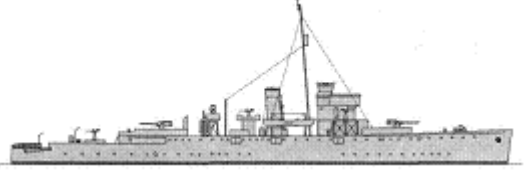
Odin	6	33	Odin	1929		1781/2038t, 86.4x9.1x4.9m, 2d/em, 4520/1390hp, 17.5/8kts, 53p, 95m; 1x1-102/40, 8-533TT
		34	Osiris	1929		
		35	Oswald	1929		
		36	Otus	1929		
		37	Olympus	1930		
		38	Orpheus	1930		
Parthian	5	39	Pandora	1930		1760/2040t, 88.1x9.1x4.9m, 2d/em, 4340/1635hp, 17/8.6kts, 53p, 95m; 1x1-102/40, 2x1-12.7, 8-533TT
		40	Perseus	1930		
		41	Proteus	1930		
		42	Parthian	1931		
		43	Phoenix	1931		
Rainbow	4	44	Regent	1930		1763/2030t, 87.5x9.1x4.9m, 2d/em, 4100/1670hp, 17/8.8kts, 53p, 95m; 1x1-102/40, 8-533TT
		45	Regulus	1930		
		46	Rover	1931		
		47	Rainbow	1931		
Thames	1	48	Thames	1932		2165/2680t, 105.2x8.6x4.8m, 2d/em, 10000/2500hp, 22.5/10kts, 61p, 60m; 1x1-120/45, 2x1-12.7, 6-533TT
Swordfish	4	49	Swordfish	1932		730/927t, 61.7x7.3x3.6m, 2d/em, 1550/1440hp, 13.7/10kts, 38p, 60m; 1x1-76/45, 1x1-12.7, 6-533TT
		50	Sturgeon	1933		
		51	Seahorse	1933		
		52	Starfish	1933		
Porpoise	1	53	Porpoise	1933		1768/2053t, 88.1x9.1x4.8m, 2d/em, 3300/1630hp, 15.5/8.7kts, 59p, 60m; 1x1-102/40, 6-533TT, 50m
Shark	2	54	Sealion	1934		768/960t, 63.6x7.3x3.6m, 2d/em, 1550/1440hp, 14/10kts, 39p, 60m; 1x1-76/45, 1x1-12.7, 6-533TT
		55	Shark	1934		

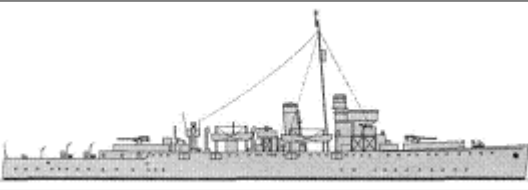
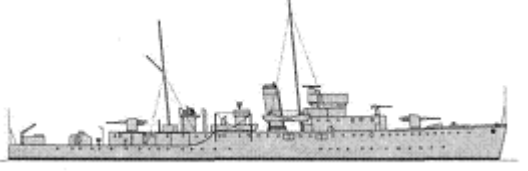
ESCORTS

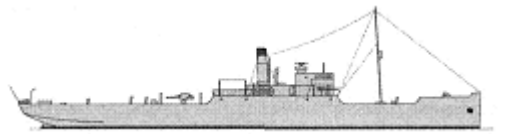

Acacia	4	1	Daffodil	1915		1275t, 80.0x10.1x3.4m, 2b, 1vte, 1800hp, 16.5kts, 90p; 2x1-102/40, 2x1-40/39, 2DCT, 1DCR, MS
		2	Foxglove	1915		
		3	Laburnum	1915		
		4	Veronica	1915		
Azalea	1	5	Heliotrope	1915		1275t, 80.0x10.1x3.4m, 2b, 1vte, 1800hp, 16.5kts, 90p; 2x1-102/40, 2x1-47/50, 2DCT, 1DCR, MS

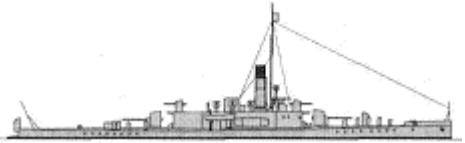
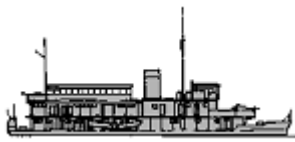
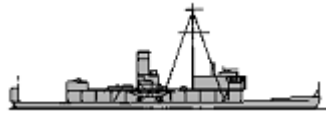
SL	Arabis	4	6	Rosemary	1915		1350t, 81.7x10.2x3.4m, 2b, 1vte, 2000hp, 16kts, 104p; 2x1-102/40, 2x1-40/39, 2DCT, 1DCR, MS	
			7	Cornflower	1916			
			8	Godetia	1916			
			9	Lupin	1916			
	Anchusa	3	10	Bryony	1917		1493t, 80.0x10.7x3.5m, 2b, 1vte, 2500hp, 17.5kts, 119p; 2x1-102/40, 2x1-76/40, 2DCT, 1DCR	
				11	Chrysanthemum			1918
				12	Harebell			1918
	Bridgewater	2	13	Bridgewater	1929		1600t, 81.2x10.4x3.7m, 2b, 2gt, 2000hp, 16.5kts, 100p; 2x1-102/45, 2x1-47/40, 1x4-12.7, 1DCR, MS	
				14	Sandwich			1929
	Hastings	4	15	Folkestone	1930		1640t, 81.2x10.4x3.8m, 2b,2gt, 2000hp, 16.5kts, 100p; 2x1-102/45, 2x1-47/40, 1x4-12.7, 1DCR, MS, 22m(17)	
				16	Scarborough			1930
				17	Hastings			1930
				18	Penzance			1931
	Shoreham	4	19	Fowey	1931		1590t, 85.8x10.7x3.4m, 2b,2gt, 2000hp, 16.5kts, 100p; 2x1-102/45, 4x1-47/40, 1x4-12.7, 1DCR, MS	
				20	Shoreham			1931
				21	Bideford			1932
				22	Rochester			1932
	Repeat Shoreham	4	23	Falmouth	1932		1515t, 85.8x10.7x3.2m, 2b,2gt, 2000hp, 16.5kts, 100p; 2x1-102/45, 4x1-47/40, 1x4-12.7, 1DCR, MS	
				24	Milford			1932
				25	Weston			1933
			26	Dundee	1933			
Grimsby	3	27	Grimsby	1934		1510t, 81.2x11.0x3.1m, 2b,2gt, 2000hp, 16.5kts, 100p; 2x1-120/45, 1x1-76/45, 4x1-47/40, 1x4-12.7, 2DCT, 1DCR		
			28	Leith			1934	
			29	Lowestoft			1934	
FS	P-boat	3	1	P40	1916		613t, 74.5x7.2x2.4m, 2b, 2t, 3500hp, 20kts, 54p; 1x1-102/40, 1x1-40/39, 3x1-356TT, 2DCR	
			2	Spey	1917			
			3	P59	1917			
	PC-boat	2	4	Dart	1918		780t, 75.3x8.2x2.4m, 2b, 2t, 3500hp, 20kts, 55p; 1x1-102/40, 2x1-76/40, 2x1-356TT, 2DCR	
				5	PC74			1918

OTHER FIGHTING SHIPS

PR	Insect	11	1	Aphis	1915		750t, 72.4x11.0x1.2m, 2b, 2vte, 2000hp, 14kts, 54-65p; 2x1-152/40(1-4,6-11), 1x1-152/40(5), 1x1-76/40
			2	Gnat	1915		
			3	Mantis	1915		
			4	Scarab	1915		
			5	Bee	1916		
			6	Cicala	1916		
			7	Cockchafer	1916		
			8	Cricket	1916		
			9	Ladybird	1916		
			10	Moth	1916		
			11	Tarantula	1916		
	Peterel	2	12	Peterel	1927	No picture	400t, 56.4x8.8x1.3m, 2b, 2gt, 2250hp, 16kts, 55p; 2x1-76/45
			13	Gannet	1928		
	Tern	2	14	Seamew	1928	No picture	330t, 51.2x8.2x1.3m, 2b, 2gt, 1370hp, 14kts, 55p; 2x1-76/45
			15	Tern	1928		
Falcon	1	16	Falcon	1931		470t, 45.7x8.8x1.8m, 2b,2gt, 2250hp, 15kts, 55p; 1x1-87/13, 2x1-57/40	
Sandpiper	1	17	Sandpiper	1933		215t, 51.0x9.4x0.6m, 1b,2vte, 600hp, 11.2kts, 35p; 1x1-87/13, 1x1-57/40	
Robin	1	18	Robin	1934		275t, 47.6x8.1x1.1m, 1b,2vte, 800hp, 12.7kts, 35p; 1x1-87/13, 1x1-57/40	

COASTAL FORCES

PT	CMB-40	1	1	CMB12	1916		5t, 13.7x2.6x0.9m, 1pe, 250hp, 25kts, 3p; 1-450TT
	CMB-70	2	8, 9	CMB103MT, 104MT	1922		24t, 22.1x4.3x1.1m, 2pe, 1400hp, 36.6kts, 5p; 1DCR, 7mines



AMPHIBIOUS



X1	11	1	X21	1915		160t, 32.2x6.4x1.1m, 1sd, 60hp, 8kts, ?p; 500troops
		2	X31	1915		
		3	X36	1915		
		4	X45	1915		
		5	X64	1915		
		6	X95	1915		
		7	X103	1915		
		8	X131	1915		

LCU			9	X134	1915		137t, 29.6x6.1x1.1m, 1sd, 60hp, 8kts, ?p; 500troops
			10	X140	1915		
			11	X149	1915		
	X201	6	12	X201	1916		
			13	X206	1916		
			14	X209	1916		
			15	X213	1916		
			16	X217	1916		
			17	X225	1916		
LCU(x)	DX1	2	1	DX1	1916		137t, 29.6x6.1x1.1m, ?p; 500troops
			2	DX2	1916		
LC	MLC1	1	1	MLC1	1926	No picture	26t, 12.2x3.5x0.4m, 2pe, 68hp, 4.7kts, 3p; 100troops
	MLC10	1	2	MLC10	1929	No picture	32t, 13.0x3.6x0.5m, 2pe, 68hp, 5kts, 3p; 1 12t tank or 100 troops

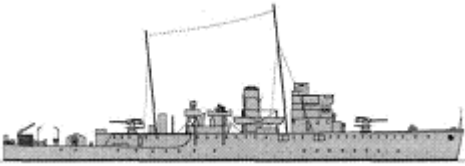
MINE WARFARE

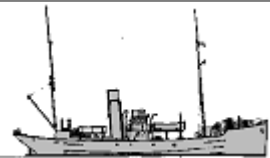
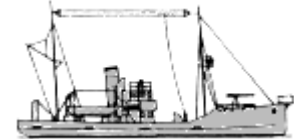
ML	M15	1	1	Medea	1915		650t, 54.0x9.4x2.0m, 2b, 2vte, 650hp, 9kts, 69p; 50mines
	M29	3	2	Medusa	1915		580t, 54.0x9.4x1.8m, 2b, 2vte, 400hp, 9kts, 72p; 50mines
			3	Melpomene	1915		
4			Minerva	1915			
AML	-	2	1	Kate Lewis	1916		207t, 24 mines
			2	Strathcoe	1916		215t, 24 mines
NL	Guardian	1	1	Guardian	1933		3665t, 103.0x16.2x4.2m, 2b,2gt, 6500hp, 18kts, 181p; 2x1-102/45, nets
			1	Aberdare	1918		
			2	Abingdon	1918		
			3	Derby	1918		
			4	Fareham	1918		
			5	Harrow	1918		
			6	Pangbourne	1918		
			7	Saltash	1918		
			8	Stoke	1918		
			9	Sutton	1918		
			10	Tiverton	1918		
			11	Widnes	1918		

MS	Hunt-II	26	12	Albury	1919		930t, 70.4x8.7x2.3m, 2b, 2vte, 2200hp, 16kts, 74p; 1x1-102/40, 1x1-76/40, MS
			13	Alresford	1919		
			14	Bagshot	1919		
			15	Carstairs	1919		
			16	Caterham	1919		
			17	Dundalk	1919		
			18	Dunoon	1919		
			19	Elgin	1919		
			20	Fermoy	1919		
			21	Forres	1919		
			22	Huntley	1919		
			23	Lydd	1919		
			24	Ross	1919		
			25	Saltburn	1919		
26	Selkirk	1919					
MS	Halcyon	3	27	Halcyon	1934		1088t, 74.8x10.2x3.1m, 2b,2vc, 1770hp, 16.5kts, 80p; 2x1-102/45, MS
			28	Harrier	1934		
			29	Skipjack	1934		
TR	Mersey	11	1	Moy	1917		665t, 45.1x7.2x2.8m, 1b, 1vte, 600hp, 11kts, ?p; 1x1-76/40, MS
			2	Ouse	1917		
			3	Doon	1917		
			4	Excellent	1918		
			5	Colne	1918		
			6	Cherwell	1918		
			7	Foyle	1918		
			8	Eden	1918		
			9	Blackwater	1918		
			10	Boyne	1918		
			11	James Ludford	1919		
TR	Castle	2	12	Madras	1919		547t, 40.8x7.2x2.8m, 1b, 1vte, 480hp, 10.5kts, ?p; 1x1-76/40, MS
			13	Sealdah	1919		
TR	Axe	4	14	Dee	1916		520t, 42.3x7.2x3.7m, 1b, 1vte, 490hp, 10.5kts, 20p; 1x1-75/50, MS
			15	Garry	1916		
			16	Kennet	1916		
			17	Liffey	1916		
TR			1	Billow	1918		
			2	Cascade	1918		

DF	Admiralty steel	22	3	Cloud	1918		200t, 28.4x5.7x2.3m, 1b, 1vte, 270hp, 9kts, ?p; 1x1-57/40, MS					
			4	Coldsnap	1918							
			5	Crescent Moon	1918							
			6	Eddy	1918							
			7	Flicker	1918							
			8	Glitter	1918							
			9	Halo	1918							
			10	Harmattan	1918							
			11	Horizon	1918							
			12	Indian Summer	1918							
			13	Landfall	1918							
			14	Leeward	1918							
			15	Lunar Bow	1918							
			16	Mist	1918							
			17	Noontide	1918							
			18	Sheen	1918							
			19	Shower	1918							
			20	Seabreeze	1919							
			21	Sundown	1919							
			22	Whirlpool	1920							
				Admiralty wooden	1			23	Fumarole	1919		175t, 28.7x6.1x2.2m, 1b, 1vte, 270hp, 9kts, ?p; 1x1-57/40, MS
			ATL	-				1	Vernon	1916		215brt

NAVAL AVIATION *(approximately, maximal number of delivered planes signed)*

Deck planes	F: 54 Nimrod I, 27 Nimrod II, 37 Osprey I; TB: 35 Baffin I; B: 20 Ripon II, 40 Ripon IIA, 31 Ripon IIC; R:
Seaplanes	F: 14 Osprey II (partly wheeled), 52 Osprey III (partly wheeled), 26 Osprey IV (partly wheeled); R: 207 Fairey IIID (partly wheeled), 90 Fairey III F I (partly wheeled), 33 Fairey III F II (partly wheeled), 269 Fairey III F III (partly wheeled), 104 Seal I (partly wheeled, delivery till 1935)

[home](#)[World navies yesterday](#)[1935](#)

United States of America 01 January 1935

IN SERVICE: 16 battleships, 3 fleet aircraft carriers, 1 light aircraft carrier, 2 seaplane tenders, 1 armoured cruiser, 15 heavy cruisers, 10 light cruisers, 216 destroyers, 84 submarines, 21 patrol ships, 2 armed yachts, 5 gunboats, 8 river gunboats, 18 submarine chasers, 16 minelayers, 35 minesweepers, 30 Coast Guard patrol ships, 71 Coast Guard patrol boats, 230 Coast Guard launches

CAPITAL SHIPS AND MONITORS

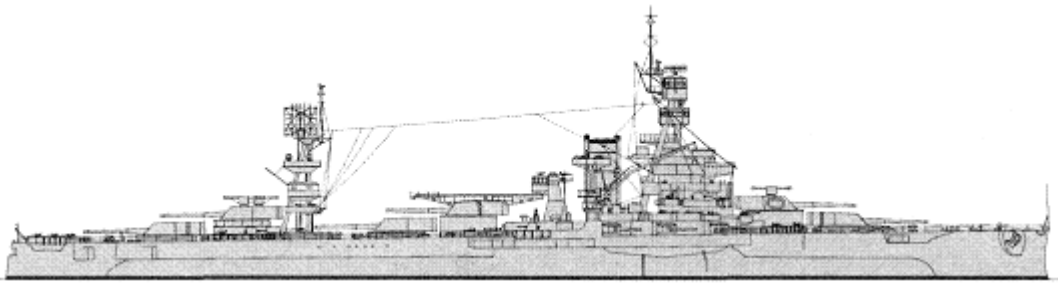
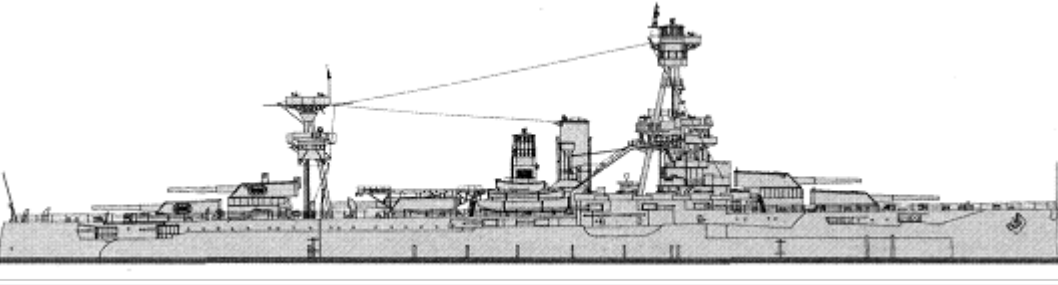
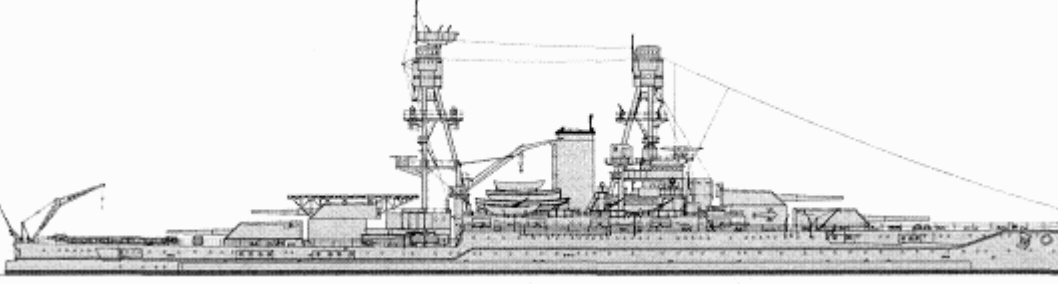
Wyoming	1	AG17	Wyoming(TS)	1912		22000(1)-30610(2)t, 171.3x32.3x9.1m, 3b(1)-4b(2),4t, 21000(1)-28000(2)hp, 18(1)-21(2)kts, 400(1)-1242(2)p; 280belt(2), 119deck, 305turrets, 292CT(2); 3x2-305/50(1), 6x2-305/50(2), 16x1-127/51, 8x1-76/50, 3seaplanes(O3U)
	2	BB33	Arkansas	1912		
New York	3	BB34	New York	1914		31924t, 174.7x32.3x9.2m, 6b,2vte, 28100hp, 21kts, 1290p; 305belt, 114deck, 356turrets, 305CT; 5x2-356/45, 16x1-127/51, 8x1-76/50, 8x1-12.7, 3seaplanes(O3U)
	4	BB35	Texas	1914		
Nevada	5	BB36	Nevada	1916		31706t, 177.7x32.9x9.0m, 6b,2gt(5)-2vte(6), 25000hp, 20.5kts, 1374p; 343belt, 127deck, 457-406turrets, 406CT; (2x3+2x2)-356/45, 12x1-127/51, 8x1-127/25, 3seaplanes(O3U)
	6	BB37	Oklahoma	1916		
	7	BB38	Pennsylvania	1916		

BB	Pennsylvania	2	8	BB39	Arizona	1916		35929t, 185.3x32.4x9.2m, 6b,4gt(7)-2t+2gt(8), 33375hp, 21kts, 1052p; 343belt, 121deck, 457turrets, 406CT; 4x3-356/45, 12x1-127/51, 8x1-127/25, 3seaplanes(O3U)
			9	BB40	New Mexico	1918		
New Mexico		3	10	BB41	Mississippi	1917		36157t, 190.2x32.4x9.4m, 4b(10)-6b(11,12),4gt, 40000hp, 22kts, 1443p; 343belt, 140deck, 457turrets, 406CT; 4x3-356/50, 12x1-127/51, 8x1-127/25, 3seaplanes(O3U)
			11	BB42	Idaho			
			12	BB43	Tennessee	1920		
Tennessee		2	13	BB44	California	1921		33190t, 190.2x29.7x9.2m, 8b,2tg,4em, 26800hp, 21kts, 1083p; 343belt, 89deck, 457turrets, 406CT; 4x3-356/50, 12x1-127/51, 8x1-127/25, 8x1-12.7, 2-533TT, 3seaplanes(O3U)
			14	BB45	Colorado	1923		
Colorado		3	15	BB46	Maryland	1921		33590t, 190.2x29.7x9.2m, 8b,2gt,4em, 28900hp, 21kts, 1080p; 343belt, 89deck, 457turrets, 406CT; 4x2-406/45, 12x1-127/51, 8x1-127/25, 8x1-12.7, 2-533TT, 3seaplanes(O3U)
			16	BB48	West Virginia	1923		

AIRCRAFT CARRYING SHIPS

	Langley	1	1	CV1	Langley	1913		15150t, 165.3x19.9x6.3m, 3b,2tg,2em, 6500hp, 15.5kts, 468p; 4x1-127/51, 34aircraft (15 F4B, 15 SU)
								2

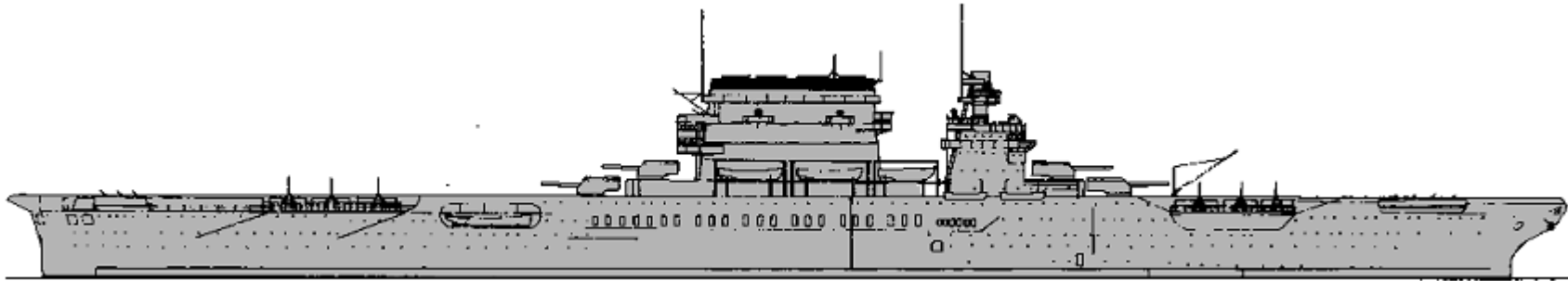
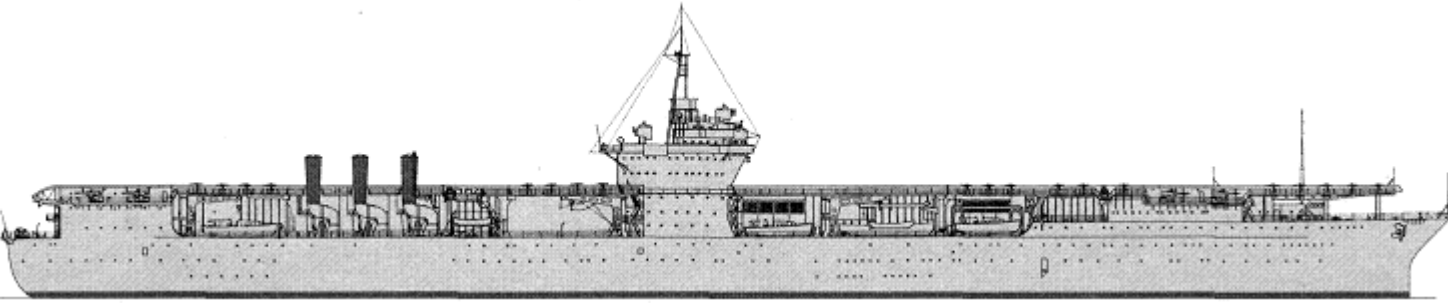
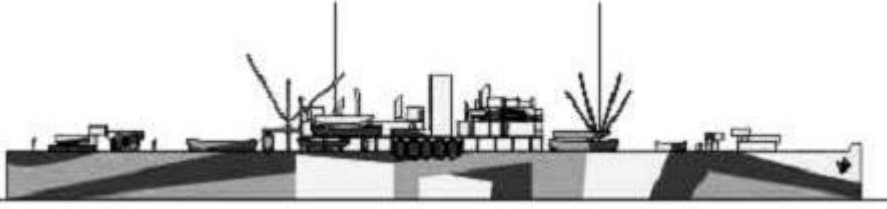
CV	Lexington	2	3	CV3	Saratoga	1927		32deck, 51CT; 4x2-203/55, 12x1-127/25, 48x1-12.7, 63aircraft (18 F2F, 18 F4B, 18 BG, 20 SBU, 3 O2U, 2 JF)
	Ranger	1	4	CV4	Ranger	1934		17577t, 234.4x33.4x6.8m, 6b,2gt, 53500hp, 29.2kts, 1788p; 51belt, 25deck; 8x1-127/25, 76aircraft (30 F2F, 30 BM/BG, 15 SBU)
AV	Wright	1	1	AV1	Wright	1921		11500t, 136.6x17.7x7.0m, 6b,1t, 6000hp, 15kts, 228p; 2x1-127/51, 2x1-76/50, 12seaplanes (O3U)
	Jason	1	2	AV2	Jason	1913	No picture	19250t, 163.4x19.8x8.4m, 3b,2tg,2em, 6500hp, 14.3kts, 82p; 4x1-102/50, 12seaplanes (O2U)



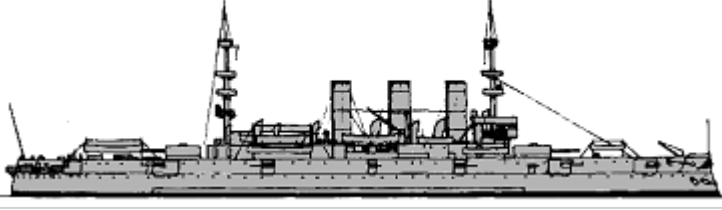
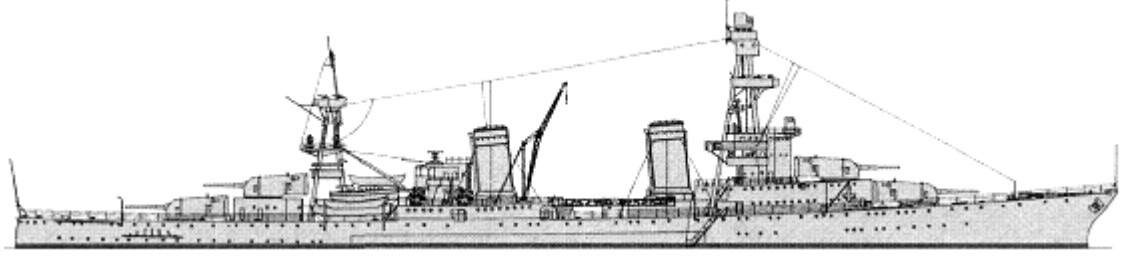

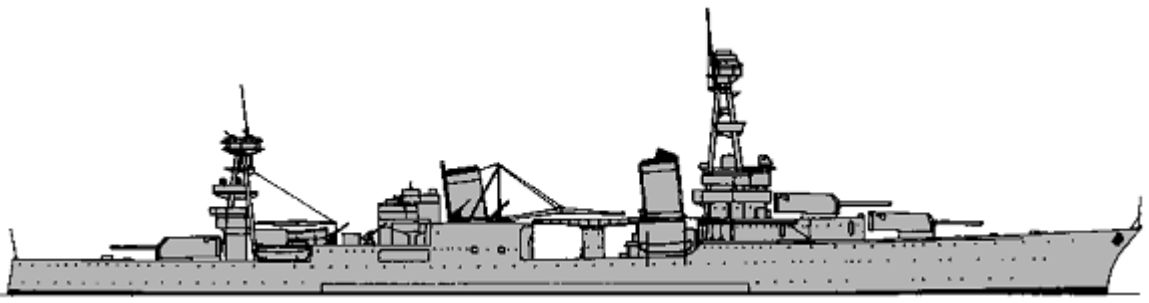
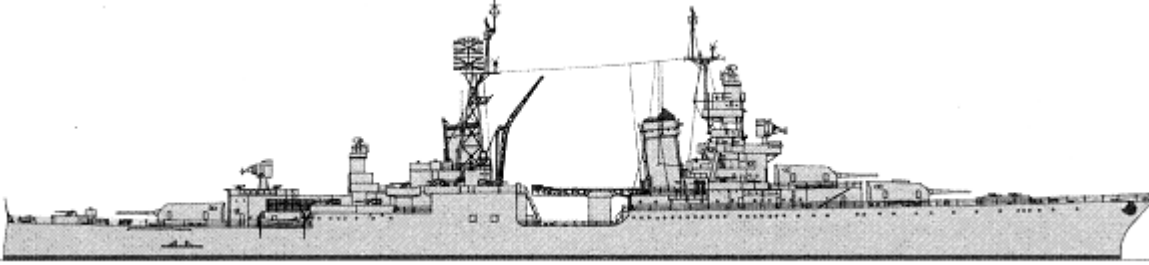
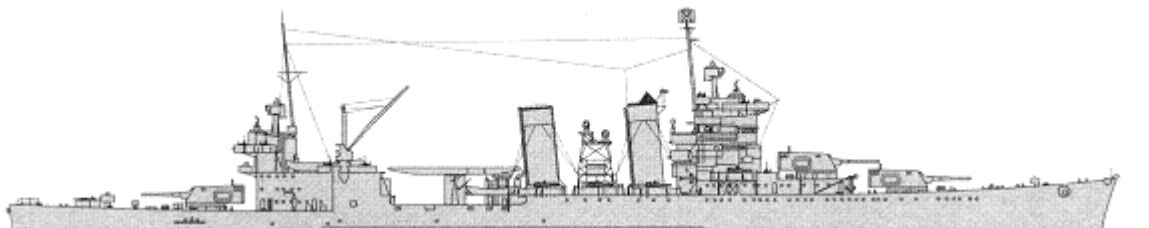
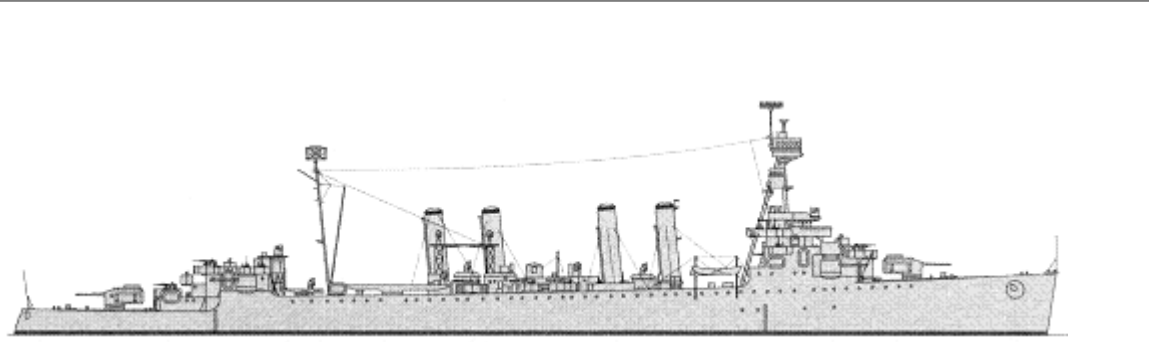
CRUISERS

New York	1	1	CA2	Rochester	1893		9021t, 117.0x19.8x7.3m, 4b,4vte(2), 5500hp, 13kts, 566p; 102belt, 152deck, 165turrets, 190CT; 2x2-203/45, 8x1-127/50, 2x1-76/50	
	2		2	CA24	Pensacola	1930		11512t, 178.5x19.9x5.9m, 8b,4gt, 107000hp, 32.5kts, 631p; 102belt, 45deck, 64turrets, 32CT; (2x3+2x2)-203/55, 4x1-127/25, 8x1-12.7, 4seaplanes (O2U)
		3	CA25	Salt Lake City	1929			
4	CA26	Northampton	1930					

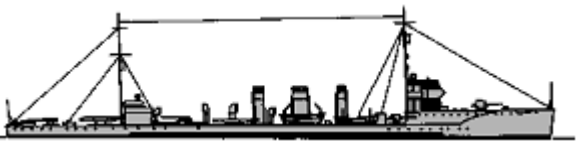
CA	Northampton	6	5	CA27	Chester	1930		11420t, 183.0x20.1x5.9m, 8b,4gt, 107000hp, 32.5kts, 617p; 95belt, 51deck, 64turrets, 32CT; 3x3-203/55, 4x1-127/25, 8x1-12.7, 4seaplanes (O3U)
			6	CA28	Louisville	1931		
			7	CA29	Chicago	1931		
			8	CA30	Houston	1930		
			9	CA31	Augusta	1931		
Portland	2	10	CA33	Portland	1933		12755t, 185.9x20.1x6.4m, 8b,4gt, 107000hp, 32.5kts, 807p; 146belt, 64deck, 64turrets, 32CT; 3x3-203/55, 8x1-127/25, 8x1-12.7, 4seaplanes (O3U)	
		11	CA35	Indianapolis	1932			
New Orleans	5	12	CA32	New Orleans	1934		12463t, 179.2x18.8x6.9m, 8b,4gt, 107000hp, 32.7kts, 868p; 127belt, 57deck, 203turrets, 127CT; 3x3-203/55, 8x1-127/25, 8x1-12.7, 4seaplanes (O3U)	
		13	CA34	Astoria	1934			
		14	CA36	Minneapolis	1934			
		15	CA37	Tuscaloosa	1934			
		16	CA38	San Francisco	1934			
CL	Omaha	10	1	CL4	Omaha	1923		9508t, 169.4x16.9x4.1m, 12b,4gt, 90000hp, 34kts, 458p; 76belt, 38deck, 32CT; (2x2+8x1)-152/53, 4x1-76/50, 2x3-533TT, 2seaplanes (O3U)
			2	CL5	Milwaukee	1923		
			3	CL6	Cincinnati	1924		
			4	CL7	Raleigh	1924		
			5	CL8	Detroit	1923		
			6	CL9	Richmond	1923		
			7	CL10	Concord	1923		
			8	CL11	Trenton	1924		
			9	CL12	Marblehead	1924		
			10	CL13	Memphis	1925		

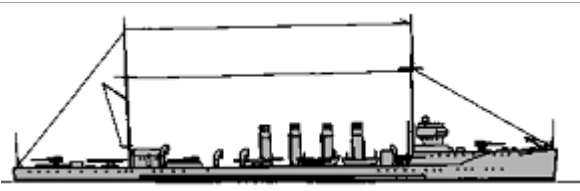
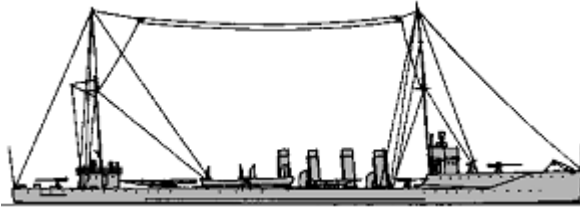
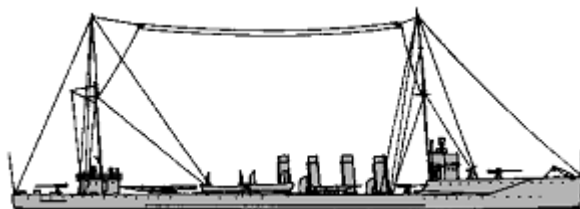
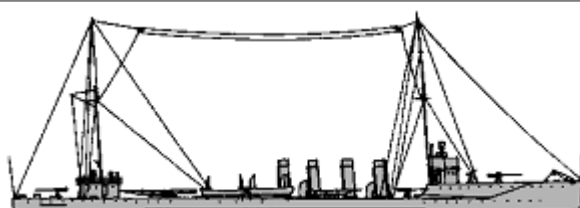
TORPEDO SHIPS

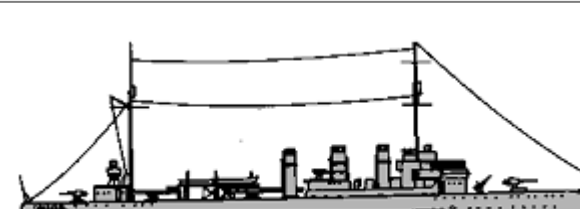
Paulding	5	1	DD23	-	1910		887t, 89.6x8.0x2.4m, 4b,3t(1)-2(2-5)t, 12000(1)-10000(2-4)-13000(5)hp, 29.5(1,5)-28(2-4)kts, 86p; 5x1-76/50, 3x2-450TT, 1DCT, 2DCR
		2	DD26	-	1910		
		3	DD27	Sterett	1910		
		4	DD30	Warrington	1911		
		5	DD31	Mayrant	1911		
Monaghan	3	6	DD34	-	1911		883t, 89.5x8.2x2.5m, 4b,2t(6)-3t(7,8), 12000(6)-10000(7,8)hp, 29.5(6)-28(7,8)kts, 89p; 5x1-76/50, 3x2-450TT, 1DCT, 2DCR
		7	DD38	Jarvis	1912		
		8	DD42	Jenkins	1912		

							
Cassin	5	9	DD46	Duncan	1913		1235t, 93.1x9.2x3.0m, 4b,2t, 16000hp, 29kts, 98p; 4x1-102/50, 4x2-450TT, 1DCT, 2DCR
		10	DD47	-	1914		
		11	DD48	Parker	1913		
		12	DD49	Benham	1914		
		13	DD50	-	1914		
O'Brien	4	14	DD51	O'Brien	1915		1171t, 93.1x9.5x2.9m, 4b,2t, 17000hp, 29kts, 101p; 4x1-102/50, 4x2-533TT, 1DCT, 2DCR
		15	DD52	Nicholson	1915		
		16	DD53	-	1915		
		17	DD55	-	1915		
Tucker	3	18	DD57	-	1916		1205t, 96.1x9.1x2.9m, 4b,2t(18,20)-2gt(19), 17000(18,20)-17500(19)hp, 29.5kts, 99p; 4x1-102/50, 4x2-533TT, 1DCT, 2DCR
		19	DD60	Wadsworth	1915		
		20	DD62	Wainwright	1916		
Sampson	3	21	DD63	Sampson	1916		1225t, 96.1x9.1x2.9m, 4b,2t, 17500hp, 29.5kts, 99p; 4x1-102/50, 2x1-12.7, 4x3-533TT, 1DCT, 2DCR
		22	DD64	Rowan	1916		
		23	DD66	Allen	1917		
Caldwell	6	24	DD69	Caldwell	1917		1187t, 96.2x9.3x2.7m, 4b,2gt(24-26,29)-3t(27,28), 18500hp, 30kts, 100p; 4x1-102/50, 2x1-12.7, 4x3-533TT, 1DCT, 2DCR
		25	DD70	Craven	1918		
		26	DD71	Gwin	1920		
		27	DD72	Conner	1918		
		28	DD73	Stockton	1917		
		29	DD74	Manley	1918		
		30	DD75	Wickes	1918		
		31	DD76	Philip	1918		
		32	DD78	Evans	1918		
		33	DD79	Little	1918		
		34	DD80	Kimberly	1918		
		35	DD81	Sigourney	1918		
		36	DD82	Gregory	1918		
		37	DD83	Stringham	1918		
		38	DD84	Dyer	1918		

39	DD85	Colhoun	1918
40	DD86	Stevens	1918
41	DD87	McKee	1918
42	DD88	Robinson	1918
43	DD89	Ringgold	1918
44	DD90	McKean	1919
45	DD91	Harding	1919
46	DD92	Gridley	1919
47	DD93	Fairfax	1918
48	DD94	Taylor	1918
49	DD95	Bell	1918
50	DD103	Schley	1918
51	DD104	Champlin	1918
52	DD105	Mugford	1918
53	DD106	Chew	1918
54	DD107	Hazelwood	1919
55	DD108	Williams	1919
56	DD109	Crane	1919
57	DD113	Rathburne	1918
58	DD114	Talbot	1918
59	DD115	Waters	1918
60	DD116	Dent	1918
61	DD117	Dorsey	1918
62	DD118	Lea	1918
63	DD120	Radford	1918
64	DD125	Tattnall	1919
65	DD126	Badger	1919
66	DD127	Twiggs	1919
67	DD128	Babbitt	1919
68	DD130	Jacob Jones	1919
69	DD131	Buchanan	1919
70	DD132	Aaron Ward	1919
71	DD133	Hale	1919
72	DD134	Crowninshield	1919
73	DD135	Tillman	1920
74	DD137	Kilty	1918
75	DD138	Kennison	1919
76	DD139	Ward	1919
77	DD140	Claxton	1919
78	DD141	Hamilton	1919
79	DD142	Tarbell	1918

Wickes

89

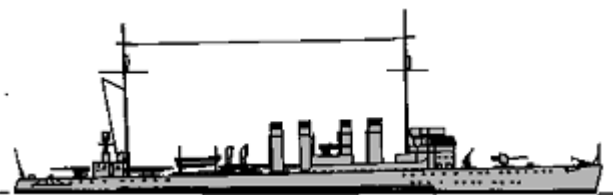

1247t, 95.8x9.4x2.8m, 4b,2t, 27000(30-63,69-93,98-118)-24900(64-68)-26000(94-97)hp, 35kts, 114p; 4x1-102/50, 1x1-76/23, 2x1-12.7, 4x3-533TT, 1DCT, 2DCR

80	DD143	Yarnall	1918
81	DD144	Upshur	1918
82	DD145	Greer	1918
83	DD146	Elliot	1919
84	DD147	Roper	1919
85	DD148	Breckinridge	1919
86	DD149	Barney	1919
87	DD150	Blakeley	1919
88	DD151	Biddle	1919
89	DD152	Du Pont	1919
90	DD153	Bernadou	1919
91	DD154	Ellis	1919
92	DD155	Cole	1919
93	DD156	J. Fred Talbot	1919
94	DD157	Dickerson	1919
95	DD158	Leary	1919
96	DD159	Schenck	1919
97	DD160	Herbert	1919
98	DD161	Palmer	1918
99	DD162	Thatcher	1919
100	DD163	Walker	1919
101	DD164	Crosby	1919
102	DD165	Meredith	1919
103	DD166	Bush	1919
104	DD167	Cowell	1919
105	DD168	Maddox	1919
106	DD169	Foote	1919
107	DD170	Kalk	1919
108	DD175	Mackenzie	1919
109	DD176	Renshaw	1919
110	DD177	O'Bannon	1919
111	DD178	Hogan	1919
112	DD179	Howard	1920
113	DD180	Stansbury	1920
114	DD181	Hopewell	1919
115	DD182	Thomas	1919
116	DD183	Haraden	1919
117	DD184	Abbot	1919
118	DD185	Bagley	1919
119	DD186	Clemson	1919

DD

120	DD187	Dahlgren	1920
121	DD188	Goldsborough	1920
122	DD189	Semmes	1920
123	DD190	Satterlee	1919
124	DD191	Mason	1920
125	DD193	Abel P. Upshur	1920
126	DD194	Hunt	1920
127	DD195	Welborn C. Wood	1921
128	DD196	George E. Badger	1920
129	DD197	Branch	1920
130	DD198	Herndon	1920
131	DD199	Dallas	1920
132	DD206	Chandler	1919
133	DD207	Southard	1919
134	DD208	Hovey	1919
135	DD209	Long	1919
136	DD210	Broome	1919
137	DD211	Alden	1919
138	DD212	Smith Thompson	1919
139	DD213	Barker	1919
140	DD214	Tracy	1920
141	DD215	Borie	1920
142	DD216	John D. Edwards	1920
143	DD217	Whipple	1920
144	DD218	Parrott	1920
145	DD219	Edsall	1920
146	DD220	MacLeish	1920
147	DD221	Simpson	1920
148	DD222	Bulmer	1920
149	DD223	McCormick	1920
150	DD224	Stewart	1920
151	DD225	Pope	1920
152	DD226	Peary	1920
153	DD227	Pillsbury	1920
154	DD228	John D. Ford	1920
155	DD229	Truxtun	1921
156	DD230	Paul Jones	1921

Clemson 96

157	DD231	Hatfield	1920
158	DD232	Brooks	1920
159	DD233	Gilmer	1920
160	DD234	Fox	1920
161	DD235	Kane	1920
162	DD236	Humphreys	1920
163	DD237	McFarland	1920
164	DD238	James K. Paulding	1920
165	DD239	Overton	1920
166	DD240	Sturtevant	1920
167	DD241	Childs	1920
168	DD242	King	1920
169	DD243	Sands	1920
170	DD244	Williamson	1920
171	DD245	Reuben James	1920
172	DD246	Bainbridge	1921
173	DD247	Goff	1921
174	DD248	Barry	1920
175	DD249	Hopkins	1921
176	DD250	Lawrence	1921
177	DD251	Belknap	1919
178	DD252	McCook	1919
179	DD253	McCalla	1919
180	DD254	Rodgers	1919
181	DD255	Osmond Ingram	1919
182	DD256	Bancroft	1919
183	DD257	Welles	1919
184	DD258	Aulick	1919
185	DD259	Turner	1919
186	DD260	Gillis	1919
187	DD263	Laub	1919
188	DD264	McLanahan	1919
189	DD265	Edwards	1919
190	DD266	Greene	1919
191	DD267	Ballard	1919
192	DD268	Shubrick	1919
193	DD269	Bailey	1919
194	DD270	Thornton	1919

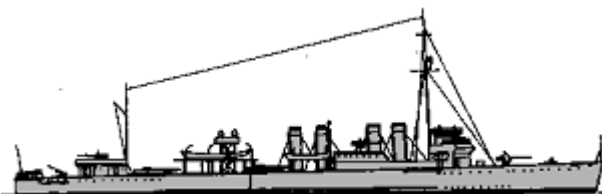

1308t, 95.8x9.4x3.0m, 4b,2gt, 27000hp, 35kts, 114p; 4x1-127/51(157-161), 4x1-102/50(119-133,136-156,162-214), 4x2-102/50(134,135), 1x1-76/23, 2x1-12.7, 4x3-533TT, 1DCT, 2DCR

		195	DD271	Morris	1919		
		196	DD272	Tingey	1919		
		197	DD273	Swasey	1919		
		198	DD274	Meade	1919		
		199	DD275	Sinclair	1919		
		200	DD302	Stoddert	1920		
		201	DD316	Sloat	1920		
		202	DD321	Marcus	1921		
		203	DD336	Litchfield	1920		
		204	DD337	Zane	1921		
		205	DD338	Wasmuth	1921		
		206	DD339	Trever	1922		
		207	DD340	Perry	1922		
		208	DD341	Decatur	1922		
		209	DD342	Hulbert	1920		
		210	DD343	Noa	1921		
		211	DD344	William B. Preston	1920		
		212	DD345	Preble	1920		
		213	DD346	Sicard	1920		
		214	DD347	Pruitt	1920		
		215	DD348	Farragut	1934	A detailed line drawing of the USS Farragut (DD-348), a Fletcher-class destroyer, shown from a starboard profile view. The ship features a complex rigging system with multiple masts and stays, and various gun mounts and deck structures.	2064t, 104.0x10.4x3.5m, 4b,2gt, 42800hp, 36.5kts, 160p; 5x1-127/38, 4x1-12.7, 2x4-533TT
Farragut	2	216	DD349	Dewey	1934		

SUBMARINES

		1	SS62	O1	1918	A simple line drawing of a submarine, likely a Sargo-class, shown from a top-down perspective. It features a conning tower with a periscope and various deck structures.	521/629t, 52.5x5.5x4.4m, 2d/em, 600/550hp, 13/11kts, 25p, 60m; 1x1-76/23, 4-450TT
		2	SS63	O2	1918		
		3	SS64	O3	1918		
		4	SS65	O4	1918		
O	9	5	SS67	O6	1918		
		6	SS68	O7	1918		
		7	SS69	O8	1918		
		8	SS70	O9	1918		
		9	SS71	O10	1918		
		10	SS78	R1	1918		
		11	SS79	R2	1919		
		12	SS80	R3	1919		

R

20

13	SS81	R4	1919
14	SS82	R5	1919
15	SS83	R6	1919
16	SS84	R7	1919
17	SS85	R8	1919
18	SS86	R9	1919
19	SS87	R10	1919
20	SS88	R11	1919
21	SS89	R12	1919
22	SS90	R13	1919
23	SS91	R14	1919
24	SS92	R15	1918
25	SS93	R16	1918
26	SS94	R17	1918
27	SS95	R18	1918
28	SS96	R19	1918
29	SS97	R20	1918



569/680t, 56.8x5.5x4.4m, 2d/em, 1200/940hp, 13.5/11kts, 29p, 60m; 1x1-76/50, 4-533TT

S-1







25

30	SS105	S1	1920
31	SS123	S18	1924
32	SS124	S19	1921
33	SS125	S20	1922
34	SS126	S21	1921
35	SS127	S22	1924
36	SS128	S23	1923
37	SS129	S24	1923
38	SS130	S25	1923
39	SS131	S26	1923
40	SS132	S27	1924
41	SS133	S28	1923
42	SS134	S29	1924
43	SS135	S30	1920
44	SS136	S31	1922
45	SS137	S32	1922
46	SS138	S33	1922
47	SS139	S34	1922
48	SS140	S35	1922
49	SS141	S36	1923
50	SS142	S37	1923
51	SS143	S38	1923
52	SS144	S39	1923
53	SS145	S40	1923

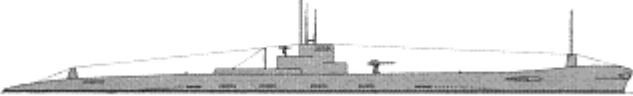

854/1062t, 66.9x6.3x4.8m, 2d/em, 1200/1500hp, 14/11kts, 38p, 60m; 1x1-102/50, 4-533TT

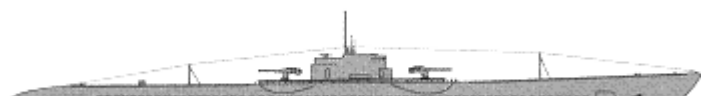
SS

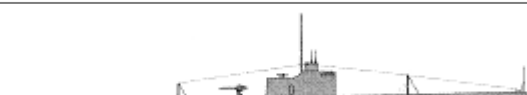

		54	SS146	S41	1924		
S-2	6	55	SS153	S42	1924		906/1126t, 68.7x6.3x4.9m, 2d/em, 1200/1200hp, 14.5/11kts, 38p, 60m; 1x1-102/50, 4-533TT
		56	SS154	S43	1924		
		57	SS155	S44	1925		
		58	SS156	S45	1925		
		59	SS157	S46	1925		
		60	SS158	S47	1925		
S-4	14	61	SS107	S3	1919		875/1088(61)-876/1092(62-74)t, 70.4x6.7x4.0m, 2d/em, 1400/1200(61)-2000/1200(62-74)hp, 15/11kts, 38p, 60m; 1x1-102/50, 5-533TT(61-70), 4-533TT(71-74)
		62	SS109	S4	1919		
		63	SS111	S6	1920		
		64	SS112	S7	1920		
		65	SS113	S8	1920		
		66	SS114	S9	1921		
		67	SS115	S10	1922		
		68	SS116	S11	1923		
		69	SS117	S12	1923		
		70	SS118	S13	1923		
		71	SS119	S14	1921		
		72	SS120	S15	1921		
		73	SS121	S16	1920		
		74	SS122	S17	1921		
S-5	1	75	SS159	S48	1922		903/1230t, 73.2x6.6x4.1m, 2d/em, 1800/1500hp, 14.5/11kts, 38p, 60m; 1x1-102/50, 5-533TT
Barracuda	3	76	SS163	Barracuda	1924		2119/2506t, 102.0x8.4x4.6m, 2d,2dg/em(2), 6200/2400hp, 18.7/9kts, 85p, 60m; 1x1-76/50, 6-533TT
		77	SS164	Bass	1925		
		78	SS165	Bonita	1926		
Argonaut	1	79	SS166	Argonaut	1928		2878/4045t, 116.1x10.3x4.9m, 2d,2dg/em(2), 3175/2200hp, 13.6/7.4kts, 86p, 95m; 2x1-152/53, 4-533TT, 60m
Narwhal	2	80	SS167	Narwhal	1930		2987/3960t, 113.1x10.1x5.2m, 2d,2dg/em(2), 5633/1600hp, 17.4/8kts, 89p, 100m; 2x1-152/53, 2x1-12.7, 6-533TT
		81	SS168	Nautilus	1930		
Dolphin	1	82	SS169	Dolphin	1932		1688/2215t, 97.3x8.5x4.0m, 2d,2dg/em(2), 3500/1750hp, 17/8kts, 63p, 75m; 1x1-76/50, 2x1-12.7, 6-533TT
Cachalot	2	83	SS170	Cachalot	1933		1120/1650t, 82.9x7.5x4.3m, 2d/em, 2770/1600hp, 17/8kts, 51p, 75m; 1x1-76/50, 3x1-12.7, 6-533TT
		84	SS171	Cuttlefish	1934		

ESCORTS

PC	Eagle	21	1	PE10	-	1919		615t, 61.2x10.1x2.6m, 2b,1gt, 2500hp, 18.3kts, 61p; 2x1-102/50, 1x1-76/50, 1DCT
			2	PE12	-	1919		
			3	PE19	-	1919		
			4	PE26	-	1919		
			5	PE27	-	1919		
			6	PE32	-	1919		
			7	PE35	-	1919		
			8	PE36	-	1919		
			9	PE38	-	1919		
			10	PE39	-	1919		
			11	PE44	-	1919		
			12	PE47	-	1919		
			13	PE48	-	1919		
			14	PE51	-	1919		
			15	PE52	-	1919		
			16	PE55	-	1919		
			17	PE56	-	1919		
			18	PE57	-	1919		
			19	PE58	-	1919		
			20	PE59	-	1919		
			21	PE60	-	1919		
AY	-	2	1	PY6	Nokomis	1914		1265t, 74.1x9.7xm, 16kts; 4x1-76/50
			2	PY10	Isabel	1917		710t

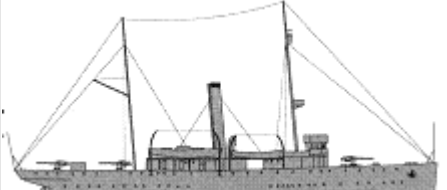
OTHER FIGHTING SHIPS

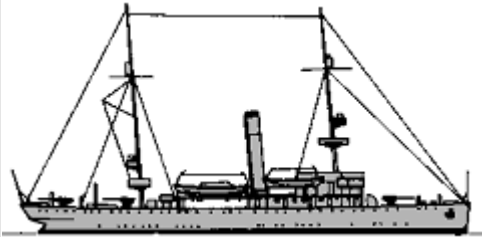
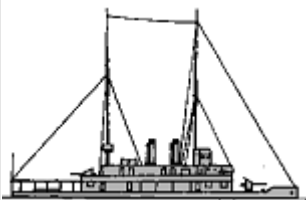
PG	Wilmington	1	1	PG8	Wilmington	1897		1689t, 76.4x12.5x2.7m, 6b,2vte, 1900hp, 15kts, 199p; 25belt, 38deck; 8x1-102/40
	Sacramento	1	2	PG19	Sacramento	1914		1592t, 69.0x12.5x3.5m, 2b,1vte, 950hp, 12.5kts, 163p; 3x1-102/50
	Asheville	2	3	PG21	Asheville	1920		1760t, 73.5x12.6x3.4m, 3b,1gt, 850hp, 12kts, 159p; 3x1-102/50; 60troops
		4	PG22	Tulsa	1923			

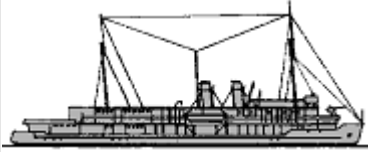
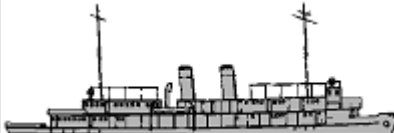
								
	Fulton	1	5	PG49	Fulton	1914	No picture	1308t, 69.0x10.7x4.0m, 2b,1vte, 12kts, 135p; 2x1-76/50
PR	Palos	1	PR1		Palos	1914		204t, 48.8x7.5x0.7m, 2b,2vte, 800hp, 13.3kts, 47p; 2x1-57/40
		2	PR2		Monocacy	1914		
	Guam	3	PR3		Guam	1927		395t, 48.6x8.3x1.6m, 2b,2vte, 1950hp, 14.5kts, 70p; 2x1-76/50
		4	PR4		Tutuila	1928		
	Panay	5	PR5		Panay	1928		474t, 58.2x8.6x1.6m, 2b,2vte, 2250hp, 15kts, 70p; 2x1-76/50
6		PR6		Oahu	1928			
Luzon	7	PR7		Luzon	1928		560t, 64.2x9.5x1.7m, 2b,2vte, 3150hp, 16kts, 70p; 2x1-76/50	
	8	PR8		Mindanao	1928			

COASTAL FORCES

PS	SC-110	18	1 - 18	SC57, 64, 102, 143, 185, 192, 224, 252, 326, 328, 330, 353, 412, 431 - 433, 437, 440	-	1917 - 1919		85t, 33.5x4.5x1.7m, 3pe, 660hp, 18kts, 27p; 1x1-76/23, 1DCT
----	--------	----	--------	--	---	-------------	---	---

MINE WARFARE

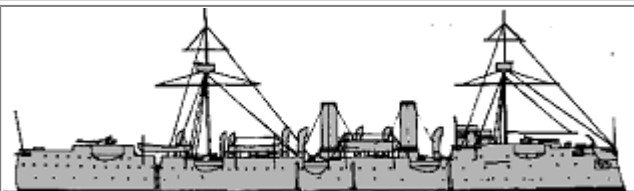
	Baltimore	1	1	CM1	Baltimore	1890		5436t, 102.1x14.8x5.9m, 8b,2hte, 10750hp, 19kts, 386p; 64deck, 76CT; 4x1-127/51, 2x1-76/50, 180m
	San Francisco	1	2	CM2	Yosemite	1890		4583t, 98.9x15.0x5.7m, 8b,2hte, 10500hp, 19kts, 384p; 51deck, 76CT; 4x1-127/51, 180m

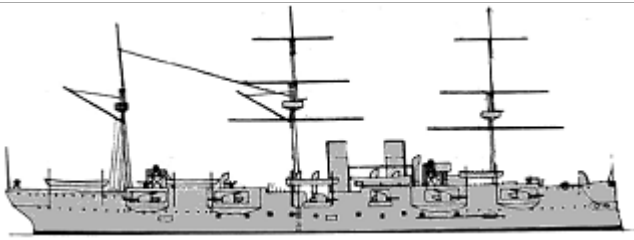
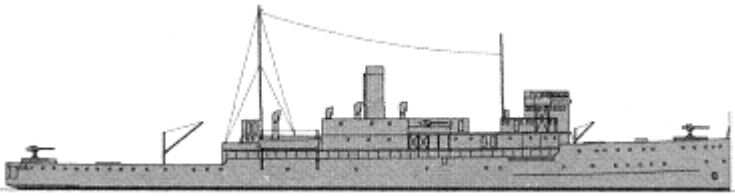
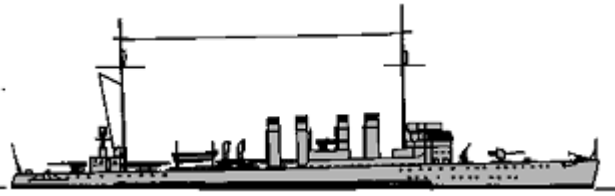
ML								
	Aroostook	2	3	CM3	Aroostook	1917		4200t, 120.4x15.9x4.9m, 8b,2vte, 7000hp, 20kts, 314p; 1x1-127/51, 2x1-76/50, 300m
			4	CM4	Oglala	1917		
Stribling	12	5	DM1	Stribling	1918		1247t, 95.8x9.4x2.8m, 4b,2t, 27000hp, 35kts, 114p; 4x1-102/50, 1x1-76/23, 2x1-12.7, 2DCR, 80m	
		6	DM2	Murray	1918			
		7	DM3	Israel	1918			
		8	DM4	Luce	1918			
		9	DM6	Lansdale	1918			
		10	DM9	Ingraham	1919			
		11	DM12	Anthony	1919			
		12	DM13	Sproston	1919			
		13	DM15	Gamble	1918			
		14	DM16	Ramsay	1919			
		15	DM17	Montgomery	1918			
		16	DM18	Breese	1918			
		1	AM1	Lapwing	1918			
		2	AM2	Owl	1918			
		3	AM3	Robin	1918			
		4	AM4	Swallow	1918			
		5	AM5	Tanager	1918			
		6	AM7	Oriole	1918			
		7	AM9	Finch	1918			
		8	AM10	Heron	1918			
		9	AM13	Turkey	1918			
		10	AM14	Woodcock	1919			
		11	AM15	Quail	1919			
		12	AM16	Partridge	1919			
		13	AM17	Eider	1919			
		14	AM18	Thrush	1919			
		15	AM19	Avocet	1919			
		16	AM20	Bobolink	1919			
		17	AM21	Lark	1919			
		18	AM23	Teal	1918			

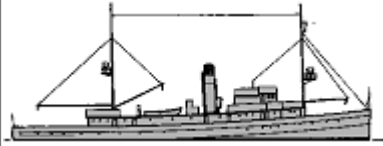
MS	Bird	35	19	AM24	Brant	1918		1400t, 57.6x10.8x3.8m, 2b,1vte, 1400hp, 13.5kts, 85p; 2x1-76/50, MS, m
			20	AM25	Kingfisher	1918		
			21	AM26	Rail	1918		
			22	AM27	Pelican	1918		
			23	AM30	Seagull	1919		
			24	AM31	Tern	1919		
			25	AM33	Penguin	1919		
			26	AM34	Swan	1919		
			27	AM35	Whippoorwill	1919		
			26	AM36	Bittern	1919		
			27	AM37	Sanderling	1918		
			28	AM40	Cormorant	1919		
			29	AM41	Gannet	1919		
			30	AM43	Grebe	1919		
			31	AM46	Peacock	1919		
			32	AM51	Sandpiper	1919		
			33	AM52	Vireo	1919		
34	AM53	Warbler	1919					
	35	AM54	Willet	1920				

COAST GUARD CUTTERS

Galveston	1	1	-	Apache	1891	No picture	708t, 57.9x8.8x2.8m, 2b,1vte, 1200hp, 12kts, 41p; 3x1-76/50
Gresham	1	2	CG1	Gresham	1897	No picture	1190t, 62.6x9.8x3.4m, 4b,1vte, 2500hp, 17kts, 73p; 4x1-76/50
Tuscarora	1	3	CG7	Tuscarora	1902	No picture	739t, 54.3x9.1x3.4m, 2b,1vte, 14.2kts, 65p; 1x1-76/50, 2x1-57/40
Pamlico	1	4	CG15	Pamlico	1907	No picture	455t, 48.2x9.1x1.7m, 1b,2vte, 600hp, 9.8kts, 33p; 2x1-57/40
Tahoma	1	5	CG21	Yamacraw	1909	No picture	1082t, 58.2x9.8x4.3m, 1vte, 14.1kts, 69p; 2x1-76/50
Snohomish	1	6		Acushnet	1908	No picture	879t, 46.3x8.8x4.2m, 2b,1vte, 1200hp, 12kts, 53p; 1x1-76/50, 2x1-57/40
Seneca	1	7	CG17	Seneca	1908	No picture	1445t, 62.2x10.4x5.2m, 2b,1vte, 1500hp, 12.5kts, 74p; 4x1-102/50
Miami	1	8	CG53	Unalga	1912	No picture	1181t, 57.9x9.9x4.3m, 1vte, 1300hp, 13kts; 2x1-102/50, 2x1-76/50, 2DCR
Ossipee	2	9	CG26	Ossipee	1915	No picture	997t, 50.5x9.8x3.6m, 2b,1vte, 1000hp, 12.7kts, 72p; 2x1-76/50, 2x1-57/40
		10	CG27	Tallapoosa	1915		
Haida	4	11	CG45	Haida	1921	No picture	1955t, 73.2x11.9x5.0m, 2b,1tg,1em, 2600hp, 15kts, 122p; 2x1-127/51, 1x1-76/50(12), 2x1-57/40, 1x1-
		12	CG46	Modoc	1922		

CGC		13	CG47	Mojave	1921		37/50(11,13,14)		
		14	CG48	Tampa	1921				
	Northland	1	15	CG49	Northland	1927		2150t, 66.0x11.9x4.2m, 2dg,1em, 1000hp, 11.5kts, 107p; 2x1-57/40, 1x1-37/50, 1seaplane (O2U)	
	Lake	10	16	CG45	Chelan	1928		2075t, 76.2x12.8x3.9m, 2b,1tg, 1em, 3350hp, 17kts, 97p; 1x1-127/51, 1x1-76/50, 2x1-57/40	
			17	CG46	Pontchartrain	1928			
			18	CG47	Tahoe	1928			
			19	CG48	Champlain	1928			
			20	CG49	Mendota	1929			
			21	CG50	Itasca	1930			
			22	CG51	Sebago	1930			
23			CG52	Saranac	1930				
Algonquin	5	24	CG53	Shoshone	1931	No picture	1005t, 50.3x11.0x3.7m, 2b,1gt, 1500hp, 12.5kts, 61p; 2x1-76/50		
		25	CG54	Cayuga	1932				
		26	CG75	Algonquin	1934				
		27	CG76	Comanche	1934				
		28	CG77	Escanaba	1932				
SC-110	8	1 - 8	WSC155, 183, 229, 231, 238, 258, 335, 438	Smith, Tingard, Boone, Blaze, Bowstring, Belleville, Cygan, Cook	1917 - 1919		85t, 33.5x4.5x1.7m, 3pe, 660hp, 18kts, 27p; 1x1-76/23, 1DCT		
		Corwin	13	9	-	Corwin	1925	No picture	210t, 30.4x7.0x1.4m, 2d, 300hp, 12kts, 15p; 1x1-76/23
				10	-	Dallas	1925		
				11	-	Dexter	1925		
				12	-	Eagle	1925		
				13	-	Forward	1925		
				14	-	Gallatin	1926		
				15	-	Mahoning	1926		
				16	-	Nansemond	1926		
				17	-	Naugatuck	1926		
				18	-	Patriot	1926		
				19	-	Perry	1926		
				20	-	Petrel	1926		
				21	-	Wolcott	1926		
				22	CG125	Active	1927		
				23	CG126	Agassiz	1927		
				24	CG127	Alert	1927		
25	CG128			Antietam	1927				
26	CG129			Bonham	1927				

CGB	Active	32	27	CG130	Boutwell	1927		289t, 38.1x7.1x2.1m, 2d, 600hp, 13.3kts, 38p; 1x1-76/23					
			28	CG131	Cahoone	1927							
			29	CG132	Cartigan	1927							
			30	CG133	Colfax	1927							
			31	CG134	Crawford	1927							
			32	CG135	Diligence	1927							
			33	CG136	Dix	1927							
			34	CG137	Ewing	1927							
			35	CG138	Faunce	1927							
			36	CG139	Frederick Lee	1927							
			37	CG140	General Greene	1927							
			38	CG141	Harriet Lane	1927							
			39	CG142	Jackson	1927							
			40	CG143	Kimball	1927							
			41	CG144	Legare	1927							
			42	CG145	Marion	1927							
			43	CG146	McLane	1927							
			44	CG147	Morris	1927							
			45	CG148	Nemaha	1927							
			46	CG149	Pulaski	1927							
			47	CG150	Reliance	1927							
			48	CG151	Rush	1927							
			49	CG152	Tiger	1927							
			50	CG153	Travis	1927							
			51	CG154	Vigilant	1927							
			52	CG155	Woodbury	1927							
			53	CG156	Yeaton	1927							
			Argo		18	54			CG100	Argo	1933	No picture	370t, 50.3x7.2x2.3m, 2d, 1340hp, 16kts, 50p; 1x1-76/23, 1x1-37/50
						55			CG101	Ariadne	1934		
						56			CG102	Atalanta	1934		
						57			CG103	Aurora	1931		
						58			CG104	Calypso	1932		
59	CG105	Cyane				1934							
60	CG106	Daphne				1932							
61	CG107	Dione				1934							
62	CG108	Galatea				1933							
63	CG109	Hermes				1932							
64	CG110	Icarus				1932							
65	CG111	Nemesis				1934							
66	CG112	Nike				1934							
67	CG113	Pandora				1934							

			68	CG114	Perseus	1932		
			69	CG115	Thetis	1931		
			70	CG116	Triton	1934		
			71	CG187	Electra	1934		
CGL	75ft	203	1 - 203	CG100 - 302	-	1924 - 1926	No picture	37t, 22.9x4.2x1.2m, 1pe, 400hp, 13.5kts; 1x1-37/50
	78ft	6	204 - 209	CG400 - 405	-	1931	No picture	43t, 24.1x4.4x1.2m, 2pe, 1200hp, 21kts; 1x1-37/50
	38ft	21	210 - 230	CG2385 - 2399, 4300 - 4305	-	1931 - 1932	No picture	11.6xxm, 1pe

NAVAL AVIATION *(approximately, maximal number of delivered planes signed)*

Deck planes	F: 21 F8C-3/OC-2 Falcon, 25 F8C-4 Falcon, 63 F8C-5 Falcon, 27 F4B-1, 46 F4B-2, 21 F4B-3, 74 F4B-4, 28 F11C-2/BFC-2 Goshawk, 27 BF2C-1 Goshawk, 25 FF-2, 33 SF-1; DB: 30 O2C-1 Falcon; TB: 102 T4M-1, 50 TG-1/2, 16 BM-1, 16 BM-2, 61 BG-1 <i>(delivery till 1935)</i> ; R: 20 OL-8A, 29 O3U-2/SU-1, 45 O3U-4/SU-2, 20 O3U-4/SU-3, 20 SU-4 <i>(delivery till 1935)</i>
Seaplanes	R: 28 OL-6, 20 OL-8, 26 OL-9, 130 O2U-1 Corsair <i>(partly wheeled)</i> , 37 O2U-2 Corsair <i>(partly wheeled)</i> , 80 O2U-3 Corsair <i>(partly wheeled)</i> , 42 O2U-4 Corsair <i>(partly wheeled)</i> , 87 O3U-1 <i>(partly wheeled)</i> , 76 O3U-3 <i>(partly wheeled)</i> , 32 O3U-6 <i>(partly wheeled, delivery till 1935)</i> , 39 OJ-2 <i>(partly wheeled)</i>

[home](#)

[World navies yesterday](#)

[1935](#)

Uruguay 01 January 1935

TORPEDO SHIPS

PGT	Uruguay	1	1	Uruguay	1910		1400t, 85.0ppx9.4x3.6m, 4b,2vte, 5700hp, 23kts, 125p; steel: 17deck; 2x1-120/45, 4x1-76/40, 6x1-37/43, 2x1-450TT
-----	---------	---	---	---------	------	--	--

© Ivan Gogin, 2011-15

[home](#)[World navies yesterday](#)[1935](#)

Venezuela 01 January 1935

OTHER FIGHTING SHIPS

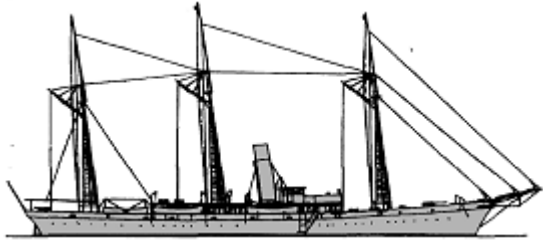
PG	Miranda	1	1	Miranda	1895	No picture	200t, 41.5x5.8x2.5m, 1b,1vte, 315hp, 10kts, 55p; 4x1-57/43
APG	-	2	1	General Salóm	1884		750t; 1x1-76/40
			2	Aragua			

© Ivan Gogin, 2011-15

[home](#)

[World navies yesterday](#)

[1935](#)

Yugoslavia 01 January 1935

IN SERVICE: 1 seaplane tender, 1 protected cruiser, 1 destroyer, 7 torpedo boats, 4 submarines, 4 river monitors, 2 motor torpedo boats, 2 river patrol launches, 12 minesweepers

IN SERVICE

AIRCRAFT CARRYING SHIPS

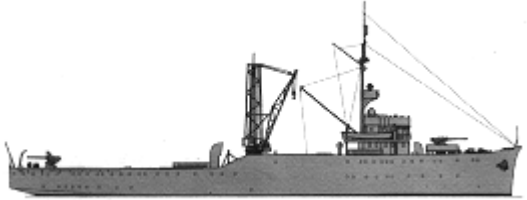

AV	Zmaj	1	1	Zmaj	1930		2084t, 83.0x12.7x3.5m, 2d, 3260hp, 15kts, 145p; 2x1-83/55, 2x2-40/6, 2seaplanes (DH.60)
----	------	---	---	------	------	---	---

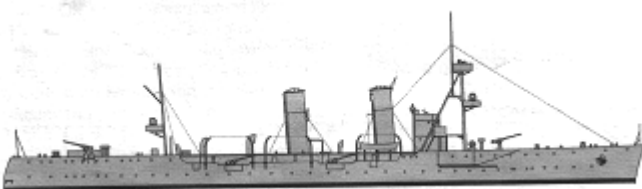
CRUISERS

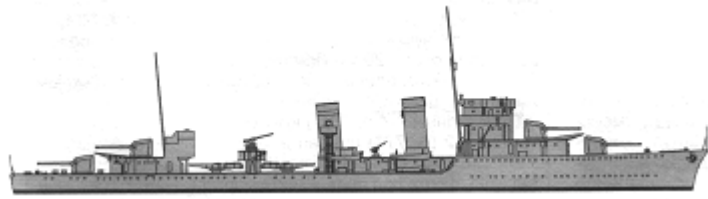

CL	Dalmacija	1	1	Dalmacija	1900		2953t, 105.0x12.2x5.2m, 8b,2vte, 8110hp, 16kts, 300p; 25deck, 50slopes, 80CT; 6x1-83/55, 4x1-47/44, 2x1-15
----	-----------	---	---	-----------	------	--	--

TORPEDO SHIPS





DD	Dubrovnik	1	1	Dubrovnik	1932		2884t, 113.2x10.7x3.6m, 3b,2gt, 42000hp, 37kts, 240p; 4x1-140/56, 1x2-83/55, (2x2+2x1)-40/67, 2x1-15, 2x3-533TT, 40m, 2DCT, 2DCR
	T1	3	2	T2	1914		320t, 58.2x5.7x1.5m, 2b,2t, 5000hp, 28kts, 52p; 2x1-66/50, 2x2-450TT

TB	T5	4	3	T3	1914		330t, 58.8x5.8x1.5m, 2b,2t, 5000hp, 28kts, 52p; 2x1-66/50, 2x2-450TT
			4	T5	1915		
			5	T6	1916		
			6	T7	1916		
			7	T8	1916		

SUBMARINES

SS	Hrabri	2	1	Hrabri	1928		975/1164t, 72.1x7.3x4.0m, 2d/em, 2400/1600hp, 15.7/10kts, 47p, 50m; 2x1-102/40, 6-533TT
			2	Nebojša	1928		
	Smeli	2	3	Smeli	1929		
			4	Osvetnik	1929		

OTHER FIGHTING SHIPS

RMON	Morava	1	1	Morava	1892		448t, 54.0x9.0x1.2m, 2b,2vte, 1200hp, 10kts, 84p; 50belt, 19deck, 75CT; 2x1-120/35, 1x1-66/42, 1x1-15
	Sava	1	2	Sava	1904		470t, 57.7x9.5x1.2m, 2b,2vte, 1400hp, 13kts, 86p; 40belt, 25deck, 75CT; 2x1-120/35, 1x1-120/10, 1x1-66/50
	Drava	1	3	Drava	1914		540t, 57.9x10.3x1.3m, 2b,2vte, 1500hp, 13kts, 95p; 50belt, 19deck, 75CT; 1x2-120/40, 3x1-120/10, 2x1-66/50
	Vardar	1	4	Vardar	1915		580t, 62.0x10.3x1.3m, 2b,2vte, 1750hp, 13.5kts, 91p; 40belt, 25deck, 50CT; 1x2-120/40, 2x1-120/10, 2x1-66/50, 2x1-47/44

COASTAL FORCES

PT	Uskok	2	1, 2	Uskok, Četnik	1928		15t, 16.8x3.4x1.2m, 2pe, 750hp, 40kts, 5p; 2-450TT
YPR	Graničar	2	1, 2	Graničar, Stražar	1930	No picture	36t, 18.2x3.0x1.0m, 1d, 120hp, 10.7kts

MINE WARFARE SHIPS

	D1	6	1	D2	1888		88t, 39.9x4.8x1.9m, 1b,1vte, 1000hp, 19kts, 16p; 2x1-37/23, MS
	Orao		2	Orao	1918		
			3	Galeb	1918		
			4	Gavran	1919		
			5	Jastreb	1919		

590t, 59.6x7.3x2.2m, 2b,2vte, 1840-1850hp, 16kts, 51p; 2x1-90/45, 24m, MS

MS							
		6	Kobac	1918			
	7	Sokol	1919				
	Malinska	5	8	Marjan	1931		
			9	Mosor	1931		
10			Malinska	1931			
11			Meljine	1931			
12			Mljet	1931			

128t, 30.1x6.7x1.7m, 1b,2vte, 280hp, 11.6kts, 27p; 1x1-66/30, 34m or MS

© Ivan Gogin, 2011