

[home](#)

# THE NAVAL BALANCE 1930

## Navies of the world

01/01/1930

1. United Kingdom - 1565 tt; 2. USA - 1556 tt; 3. Japan - 1034 tt; 4. France - 600 tt; 5. Italy - 338 tt; 6. Soviet Union - 198 tt; 7. Germany - 172 tt; 8. Argentina - 129 tt; 9. Spain - 124 tt

tt - thousand ton



[ALBANIA](#)

[ARGENTINA](#)

[AUSTRALIA](#)

[AUSTRIA](#)

[BELGIUM](#)

[BRAZIL](#)

[BULGARIA](#)

[CANADA](#)

[CHILE](#)

[CHINA](#)

[COLOMBIA](#)

[CUBA](#)

[CZECHOSLOVAKIA](#)

[DENMARK](#)

[ECUADOR](#)

[EGYPT](#)

[ESTONIA](#)

[FINLAND](#)

[FRANCE](#)

[GERMANY](#)

[GREECE](#)

[HUNGARY](#)

[ICELAND](#)

[INDIA](#)

[IRELAND](#)

[ITALY](#)

[JAPAN](#)

[LATVIA](#)

[LITHUANIA](#)

[MEXICO](#)

[NETHERLANDS](#)

[NEW ZEALAND](#)

[NORWAY](#)

[PARAGUAY](#)

[PERSIA](#)

[PERU](#)

[POLAND](#)

[PORTUGAL](#)

[ROMANIA](#)

[SIAM](#)

[SOUTH AFRICA](#)

[SOVIET UNION](#)

[SPAIN](#)

[SWEDEN](#)

[TURKEY](#)

[UNITED KINGDOM](#)

[UNITED STATES OF AMERICA](#)

[URUGUAY](#)

[VENEZUELA](#)

[YUGOSLAVIA](#)

**1576494**

[Website Hit Counter](#)

[home](#)[World navies yesterday](#)[1930](#)

## Albania 01 January 1930

### OTHER FIGHTING SHIPS

PG	Shqipnía	2	1	Shqipnía	1922		193t, 43.0x6.0x1.4m, 1b,2vte, 600hp, 14kts, 35p; 1x1-88/30
			2	Skënderberg	1918		

### COASTAL FORCES

YP	Tirana	4	1-4	Tirana, Saranda, Durrës, Shëngjun	1926	No picture	46t, 24.4xxm, d, 450hp, 17kts; 1x1-76/40
----	--------	---	-----	-----------------------------------	------	------------	--

© Ivan Gogin, 2011-15

[home](#)

[World navies yesterday](#)

[1930](#)

# Argentina 01 January 1930

## BATTLESHIPS

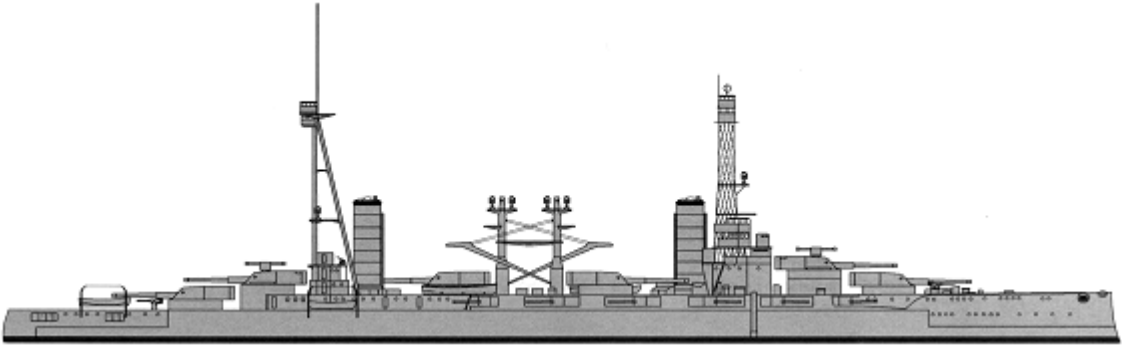
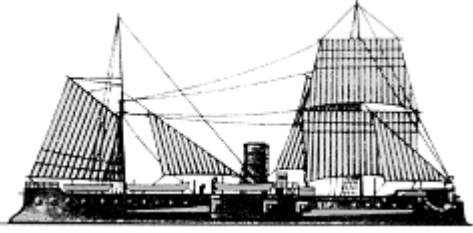
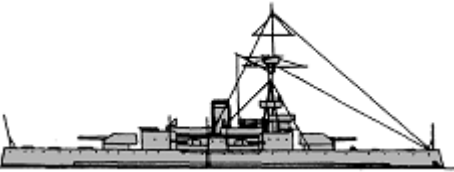

BB	Rivadavia	1	Rivadavia	1914		<p>30600t, 181.3x30.0x8.5m, 18b,3gt, 45000hp, 20kts, 1130p;280belt (76+38)deck, 305turrets, 305CT; 6x2-305/50, 12x1-152/50, 4x1-76/50, 2-533TT</p>
		2	Moreno	1915		
BC	Almirante Brown	1	Almirante Brown	1882		<p>4200t, 73.2ppx15.2x6.2m, 8b,2vc, 5400hp, 14kts, 520p; compound: 229belt, 203battery, 203CT; 10x1-150/50, 6x1-120/50, 2x1-47/40, 2-450TT</p>
		2	Libertad	1892		
	Nueve de Julio	3	Independencia			<p>2595t, 70.1ppx13.1x4.0m, 4b,2vte, 2800hp, 14kts, 230p; steel: 203belt, 37deck, 127turrets, 102CT; 2x1-240/35, 4x1-120/40, 4x1-47/40</p>
		2				

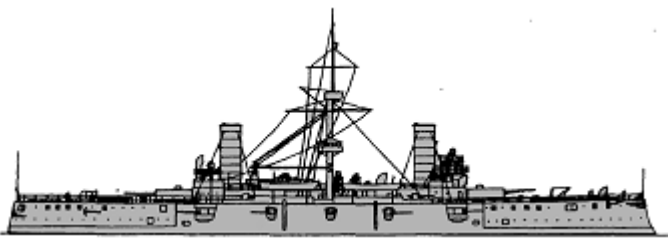
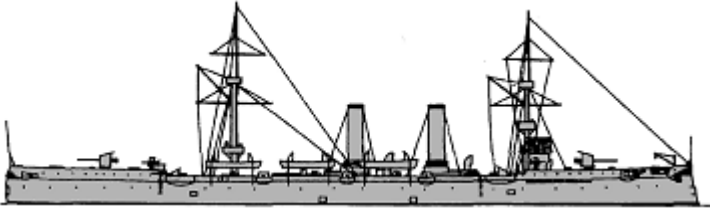
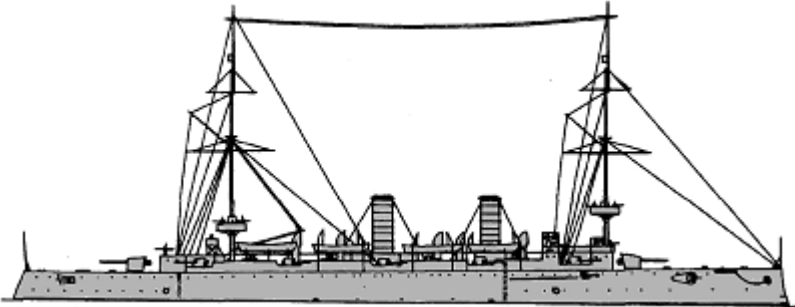

## CRUISERS

CA	Garibaldi	1	Garibaldi	1896		<p>6775t, 111.7x18.2x7.1m, 8b(1-3)-16b(4),2vte, 13000hp, 20kts, 500-540hp; Harvey(1-3): 150belt, 37deck, 150turrets, 150CT; 2x1-254/40(1,3,4), 2x2-203/45(2), 10x1-152/40(1,2), 14x1-152/40(3,4), 6x1-120/40(1,2), 2x1-76/40(1,2,4), 4x1-76/40(3), 2x1-57/40(1), 4x1-57/40(2-4)</p>
		2	San Martin	1898		
		3	General Belgrano	1898		
		4	Pueyrredon	1898		

							
CL	Nueve de Julio	1	1	Nueve de Julio	1893		3600t, 113.5x13.4x5.0m, 8b,2vte, 14500hp, 22.2kts, 327p; steel: 114slopes, 89deck, 51shields, 102CT; 4x1-152/40, 8x1-120/40, 12x1-47/40, 5-450TT
	Buenos Aires	1	2	Buenos Aires	1896		4788t, 129.2x12.9x5.6m, 8b,2vte, 17000hp, 24kts, 350p; steel: 127slopes, 38deck, 114shields, 152CT; 2x1-203/45, 4x1-152/45, 6x1-120/45, 16x1-47/40, 5-450TT

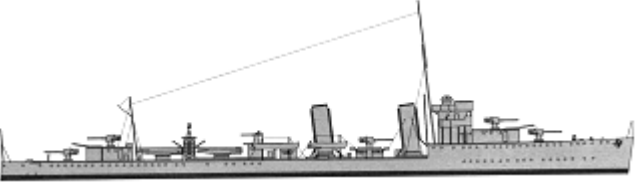
### TORPEDO SHIPS

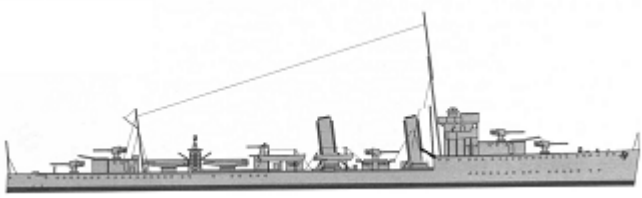
DD	Corrientes	3	1	Corrientes	1898		280t, 57.9x5.9x2.2m, 6b,2vte, 4200hp, 27kts, 54p; steel: 20belt; 1x1-75/55, 3x1-57/40, (1+2x1)-450TT
			2	Entre Rios	1896		
			3	Misiones	1897		
	Catamarca	2	4	Catamarca	1912		1357t, 88.1x8.3x2.6m, 2b,2t, 24000hp, 32kts, 150p; 3x1-102/50, 2x1-40/39, 2x2-533TT, 1DCT
			5	Jujuy	1912		
	La Plata	2	6	Córdoba	1912		1368t, 90.0x9.0x2.8m, 5b,2t, 24000hp, 32kts, 150p; 3x1-102/50, 2x2-40/39, 2x2-533TT, 1DCT
			7	La Plata	1912		
	Cervantes	2	8	Cervantes	1927		2087t, 101.5x9.7x3.7m, 4b,2gt, 42000hp, 36kts, 175p; 5x1-120/45, 1x1-76/45, 2x3-533TT, 2DCR
			9	Juan de Garay	1927		
	Mendoza	3	10	Mendoza	1929		2120t, 102.1x9.7x3.8m, 4b,2gt, 42000hp, 36kts, 160p; 5x1-120/45, 1x1-76/45, 2x1-40/39, 2x3-533TT
			11	La Rioja	1929		

							
			12	Tucuman	1929		
TB	Bouchard	1	1	Bouchard	1890		90t, 39.6ppx4.3x1.8m, 2b,1vte, 1110hp, 23.5kts, 15p; 2x1-47/43, 1x4-25/40, (1+1x2)-450TT

## OTHER FIGHTING SHIPS

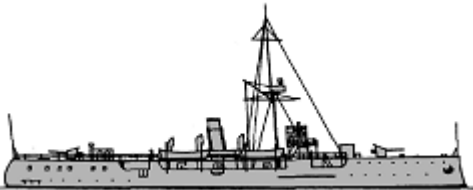
			1	Rosario	1909		1055t, 76.4x9.8x2.1m, 2b,2vte, 1300hp, 14.5kts, 145p; 76belt, 25deck, 76CT; 2x1-152/13, 6x1-76/40
PGR	Rosario	2	2	Paraná	1909		

## MINE WARFARE SHIPS

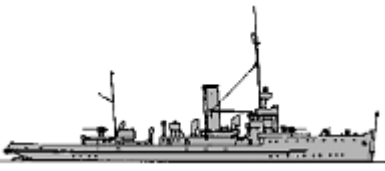
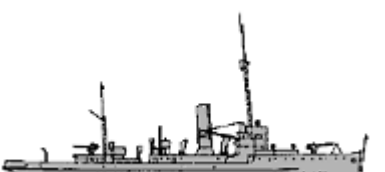
	M1	4	1	M1	1916		513(1)-503(2-4)t, 58.3(1)-58.2(2-4)x7.3x2.3m, 2b,2vte, 1800(1,4)-1890(2,3)hp, 16.5kts, 40p; 3x1-75/55, 30m, MS
			2	M2	1916		
			3	M3	1916		
			4	M4	1916		
MS	M5	5	5	M5	1918		553(5-7)-548(8)-564(9)t, 58.2(5)-59.3(6-9)x 7.3(5,8)-7.4(6,7,9)x 2.3(5,9)-2.2(6,7,8)m, 2b,2vte, 1790(5)-1850(6-9)hp, 16(5,7,9)-16.3(6,8)kts, 40p; 3x1-75/55, 30m, MS
			6	M6	1919		
			7	M7	1919		
			8	M8	1918		
			9	M9	1918		

© Ivan Gogin, 2011-15

[home](#)

[World navies yesterday](#)

[1930](#)

# AUSTRALIA 01 January 1930

## AIRCRAFT CARRYING SHIPS

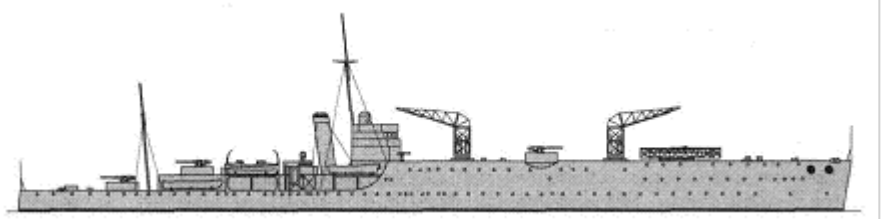
AV	Albatross	1	1	Albatross	1929		6350t, 135.3x23.7x5.3m, 4b, 2gt, 12000hp, 21kts, 450p; 4x1-120/40, 4x1-47/40, 4x1-40/39, 9seaplanes (6 Fairey IIID)
----	-----------	---	---	-----------	------	--	---

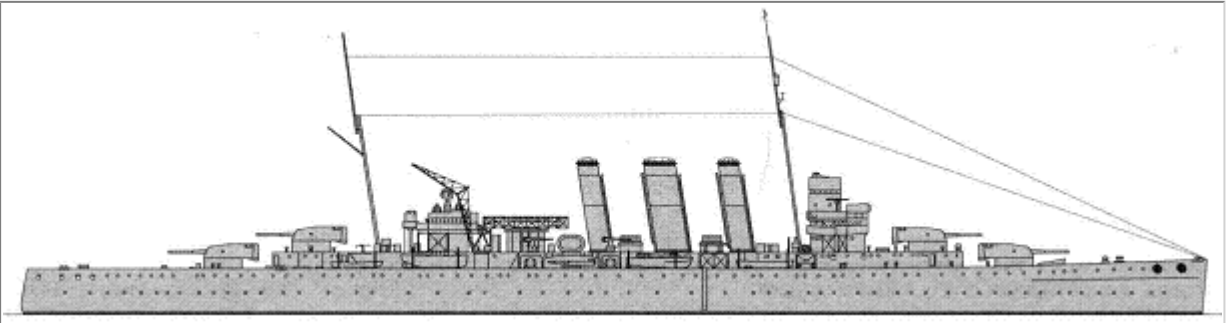
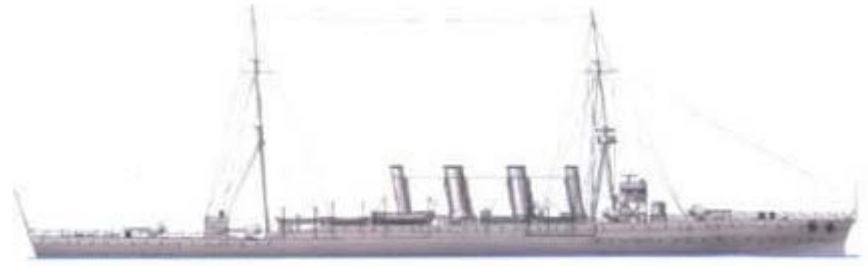

## CRUISERS

CA	Kent	2	2	Canberra	1928		13400-13540t, 192.0-192.9x20.8x6.3m, 8b, 4gt, 80000hp, 31.5kts, 710p; 25belt, 111magazines, 38deck, 25turrets; 4x2-203/50, 4x1-102/45, 4x1-47/40, 4x1-40/39, 2x4-533TT
CL	Chatham	1	1	Brisbane	1916		6000t, 139.6x14.9x4.9m, 12b, 4t, 25000hp, 25.5kts, 475p; 51belt, 102shields, 38deck, 102CT; 8x1-152/45, 1x1-76/45, 4x1-47/40, 2-533TT
							6160t, 141.0x14.9x4.9m, 12b, 2gt, 25500hp, 25.5kts, 480p;

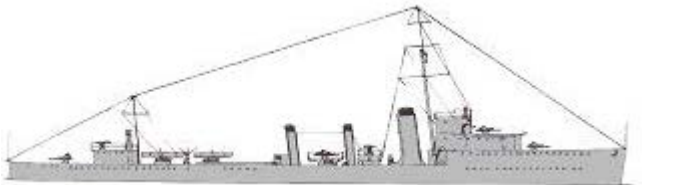

	Birmingham	1	2	Adelaide	1922		51belt, 102shields, 38deck, 102CT; 9x1-152/45, 1x1-76/50, 1x1-76/45, 4x1-47/40, 2-533TT
--	------------	---	---	----------	------	---	---

## TORPEDO SHIPS

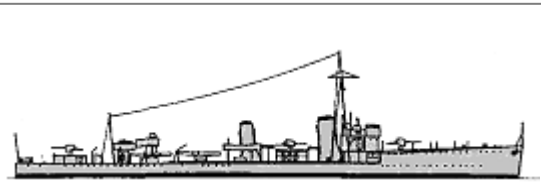
DL	Parker	1	1	Anzac	1917		1912t, 99.0x9.7x3.7m, 4b, 3t, 36000hp, 34kts, 116p; 4x1-102/40, 2x1-40/39, 2x2-533TT
I-Australian		2	2	Huon	1915		990t, 75.0x7.8x2.7m, 3b, 3t, 13500hp, 27kts, 70p; 1x1-102/40, 3x1-76/40, 3x1-450TT
			3	Torrens	1916		
DD	S-Admiralty	5	4	Stalwart	1918		1225t, 84.1x8.1x2.7m, 3b, 2gt, 27000hp, 36kts, 90p; 3x1-102/40, 1x1-40/39, 2x2-533TT, 2DCT, 1DCR
			5	Success	1919		
			6	Swordsman	1919		
			7	Tasmania	1919		
			8	Tattoo	1919		

## SUBMARINES

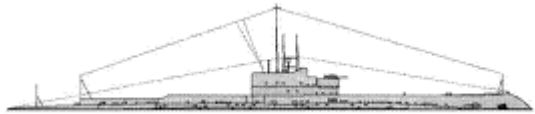
SS	Oxley	2	1	Otway	1927		1636/1872t, 83.8x8.4x4.8m, 2d/em, 3100/1350hp, 15/8.5kts, 55p, 60m; 1x1-102/40, 8-533TT
			2	Oxley	1927		

## ESCORTS

SL	Acacia	1	1	Mallow	1915		1275t, 80.0x10.1x3.4m, 2b, 1vte, 1800hp, 16.5kts, 90p; 2x1-102/40, 2x1-40/39, 2DCT, 1DCR, MS
	Arabis	2	2	Geranium	1916		
3			Marguerite	1916	1350t, 81.7x10.2x3.4m, 2b, 1vte, 2000hp, 16kts, 104p; 2x1-102/40 or 2x1-120/40, 2x1-47/50, 2DCT, 1DCR, MS		



© Ivan Gogin, 2010-15

[home](#)

[World navies yesterday](#)

[1930](#)

## Austria 01 January 1930

### RIVER BOATS



PGR	Fogas	1	1	Birago	1916		60t, 36.0x4.6x0.9m, 2b,2vte, 800hp, 12kts, 27p; 5belt, 4deck, 5turret, 5CT; 1x1-66/30
-----	-------	---	---	--------	------	---	---

© Ivan Gogin, 2011-15

[home](#)[World navies yesterday](#)[1930](#)

## BELGIUM 01 January 1930

### TORPEDO SHIPS

TB	A1	9	1	A2 Prince Charles	1915		137t, 41.6x4.6x1.2m, 1b,1vte, 1093hp, 19kts, 28p; 1x1-50/40, 2x1-450TT, 4m, MS
			2	A4	1915		
			3	A5	1915		
			4	A8	1915		
			5	A9	1915		
			6	A10	1915		
			7	A12	1915		
			8	A16	1915		
			9	A20	1915		
	A22	3	10	A42	1917		250t, 50.0x5.3x2.1m, 1b,1gt, 3250hp, 25kts, 29p; 2x1-88/30, 1x1-450TT, MS
			11	A43	1917		
			12	A47	1917		

### ESCORTS

FPV	Flower	1	1	Zinnia	1915		1275t, 80.0x10.1x3.4m, 2b,1vte, 1400hp, 14kts, 90p
-----	--------	---	---	--------	------	--	--

© Ivan Gogin, 2010-15

[home](#)[World navies yesterday](#)[1930](#)

## Brazil 01 January 1930

### BATTLESHIPS

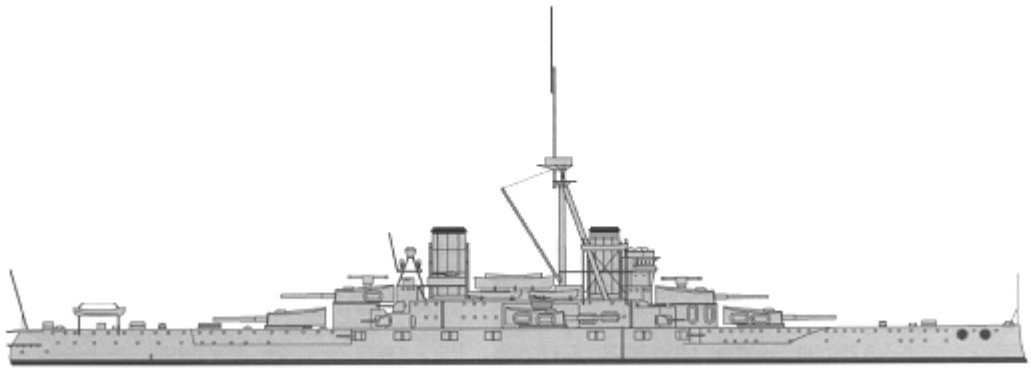
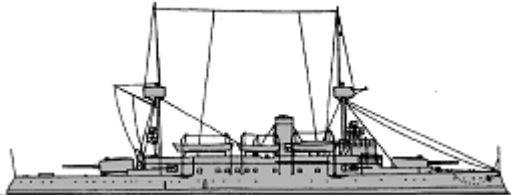

BB	Minas Gerais	1	Minas Gerais	1910		21200t, 165.5x25.33x7.6m, 18b,2vte, 23500hp, 21kts, 900p; 229belt, 51deck, 229turrets, 305CT; 6x2-305/45, 12x1-120/50, 2x1-76/50, 8x1-37/32
		2	São Paulo	1910		
BC	Marshal Deodoro	1	Marshal Floriano	1901		3162t, 81.5x14.4x4.2m, 8b,2vte, 3400hp, 15kts, 200p; Harvey: 350belt, 45deck, 220turrets, 125CT; 2x1-234/45, 4x1-120/50, 6x1-57/40, 2-450TT

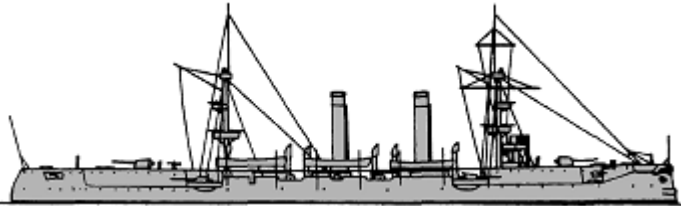
### CRUISERS

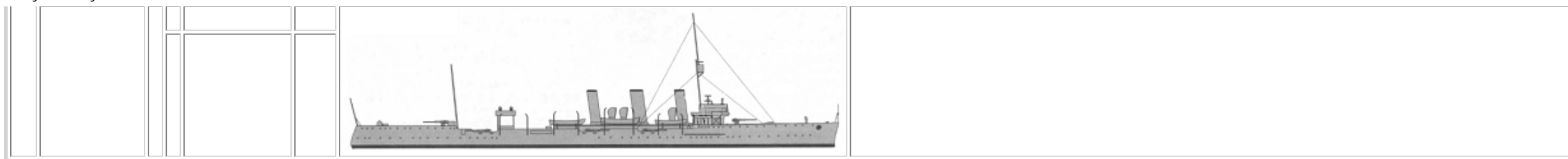
CL	Almirante Barroso	1	Almirante Barroso	1897		3437t, 108.0x13.3x5.2m, 4b,2vte, 7500hp, 20.2kts, 366p; Harvey: 88slopes, 31deck, 102CT; 6x1-152/50, 4x1-120/50, 10x1-57/40, 4x1-37/23, 3-450TT
	Bahia	2	Bahia	1910		
		3	Rio Grande do Sul	1910		3185t, 122.4x11.9x4.4m, 6b,3gt, 22000hp, 28kts, 350p; 31slopes, 19deck, 76CT; 10x1-120/50, 4x1-76/40, 4x1-47/40, 2x2-533TT



## TORPEDO SHIPS

DD	Pará	10	1	Amazonas	1909		560t, 73.2ppx7.2x2.4m, 2b,2vte, 8000hp, 27kts, 130p; 2x1-102/40, 4x1-47/40, 2x1-450TT
			2	Pará	1909		
			3	Piauí	1909		
			4	Rio Grande do Norte	1909		
			5	Paraíba	1909		
			6	Alagoas	1910		
			7	Sergipe	1910		
			8	Paraná	1910		
			9	Santa Catharina	1910		
			10	Mato Grosso	1909		
		Alexandrino Dealenca	1	11	Maranhão	1914	
TB	Goiás	1	1	Goiás	1907	No picture	150t, 46.3ppx4.7x1.3m, 2vte,1t(3), 950hp, 26kts, 30p; 2x1-47/40, 2x1-450TT

## SUBMARINES

SS	F1	3	1	F1	1913		250/305t, 46.0ppx4.4x3.7m, 2d/em, 700/500hp, 13.5/8kts, 20p, 40m; 2-450TT
			2	F2	1914		
			3	F3	1914		
	Humaytá	1	4	Humaytá	1929		1450/1884t, 86.7x7.8x4.3m, 2d/em, 4000/1000hp, 18.5/10kts, 61p, 100m; 1x1-120/41, 2x1-13.2, 6-533TT, 16m

## OTHER FIGHTING SHIPS

RMON	Pernambuco	1	1	Pernambuco	1910		470t, 44.5x7.3x1.6m, 2b,2vte, 800hp, 11kts, 60p; 168belt, 102deck, 152turret, 89CT; 1x2-120/45, 2x1-57/43, 2x1-37/32
PGR	Yutohy	1	1	Teffé	1892	No picture	33t, 27.4ppx4.6x1.5m, 11kts; 1x1-47/40
	Acre	1	2	Missões	1906	No picture	200t, 36.6x6.1x0.6m, 1b,1vte, 300hp, 11kts; 1x1-87/13, 1x1-57/43
			1	Oyapock	1908		295t

APGR	-	4	2	Teniente Mário Alves	1913		280t
			3	Amapá	1912		320t
			4	Ajuricaba	1923		120t

### MINE WARFARE SHIPS



AML	-	1	1	Tenente Maria do Couto			340t; 30m
AMS	-	2	1	Heitor Perdigão	1921		500t
			2	Muniz Freire	1921		500t

© Ivan Gogin, 2011-15



[home](#)[World navies yesterday](#)[1930](#)

## Bulgaria 01 January 1930

### TORPEDO SHIPS

TB	Druzki	4	1	Druzki	1908		98t, 38.0x4.4x1.3m, 2b,1vte, 1950hp, 26kts, 32p; 2x1-47/50, MS
			2	Smeli	1908		
			3	Khrabri	1908		
			4	Strogi	1909		
	Vasil Levski	2	5, 6	Vasil Levski, Khristo Botev	1877-1878		20t, 18.3x2.3x1.1m, 1b,1vc, 220hp, 13kts, 9p

### COASTAL FORCES

PS	Belomorets	2	1, 2	Belomorets, Chernomorets	1917		87t, 33.5x4.5x1.7m, 3pe, 660hp, 18kts, 27p; 1x1-47/50
YP	Minyor	4	1-4	Minyor, Vzriv, Konduktor Dokuzanov, Kapitan-Leytenant K. Minkov	1918		41t, 23.4x3.7x1.5m, 2pe, 440hp, 14kts, 16p; 1x1-75/35, 1DCT

© Ivan Gogin, 2011-15



[home](#)

[World navies yesterday](#)



[1930](#)

# CANADA 01 January 1930

## TORPEDO SHIPS

DD	S-Thornycroft	2	1	Champlain	1919		1240t, 84.1x8.3x3.2m, 3b, 2gt, 27000hp, 36kts, 90p; 3x1-102/40, 1x1-40/39, 2x2-533TT, 2x1-450TT, 2DCT, 1DCR
			2	Vancouver	1919		

## MINE WARFARE

TR	Castle	1	1	TR39	1918		547t, 40.8x7.2x2.8m, 1b, 1vte, 480hp, 10.5kts, ?p; 1x1-76/40, MS
	Ypres	6	2	Festubert	1917	No picture	440t, ~42x7.1x4.1m, 1b, 1vte, ?hp, 10.5kts, ?p; 1x1-76/40, MS
	3		Ypres	1917			
	4		Armentiers	1918			
	5		Arras	1918			
	6		Givenchy	1918			
			7	Thiepval	1918		
DF	Admiralty wooden	1	1	Ebbtide	1917		175t, 28.7x6.1x2.2m, 1b, 1vte, 270hp, 9kts, ?p; 1x1-57/40, MS

[home](#)[World navies yesterday](#)[1930](#)

## Chile 01 January 1930

### CAPITAL SHIPS

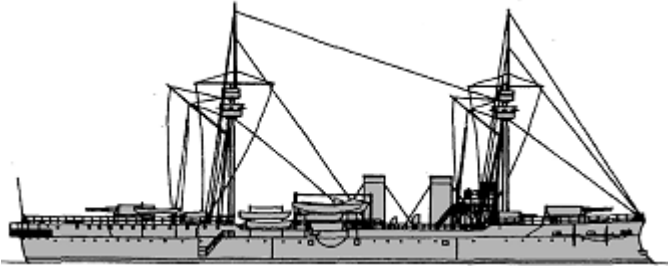
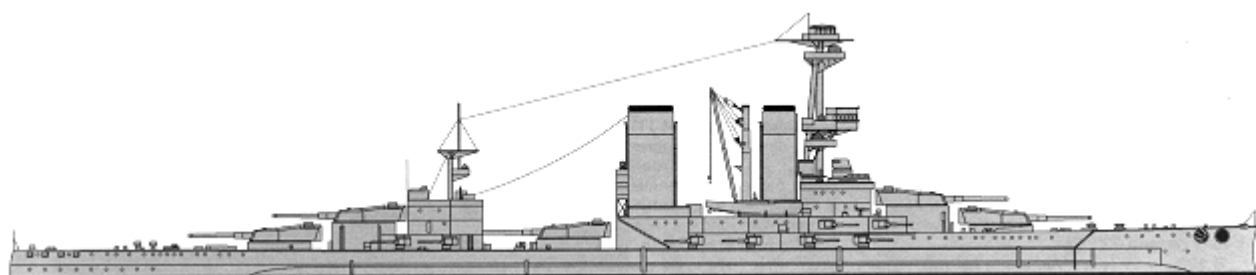
BB	Capitán Prat	1	1	Capitán Prat	1893		6901t, 100.0ppx18.5x7.0m, 12b,2hte, 12000hp, 19kts, 480p; Creusot steel; 300belt, 50deck, 275barbettes, 265CT; 4x1-240/36, 4x2-120/45, 10x1-57/40, 2-450TT
	Almirante Latorre	1	2	Almirante Latorre	1915		32300t, 201.5x28.0x8.7m, 21b,4t, 37000hp, 22.7kts, 1167p; 229belt, (25+37)deck, 254turrets, 279CT; 5x2-356/45, 14x1-152/50, 2x1-76/45, 4-533TT

### CRUISERS

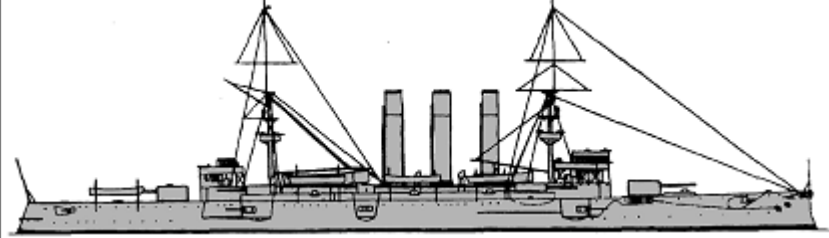
CA	O'Higgins	1	1	O'Higgins	1898		8500t, 135.2x19.1x6.7m, 30b,2vte, 16000hp, 21kts, 500p; Harvey; 178belt, 51deck, 178turrets, 229CT; 4x1-203/40, 10x1-152/40, 13x1-76/40, 3-450TT
	Presidente Errázuriz	1	1	Presidente Errázuriz	1892		2047t, 81.8ppx10.9x4.4m, 4b,2hte, 5400hp, 18.3kts, 170p; Steel; 60slopes, 35deck, 90shields, 50CT; 4x1-150/45, 2x1-120/45, 4x1-57/40, 3-356TT

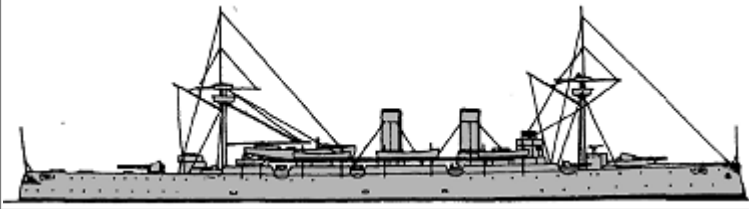
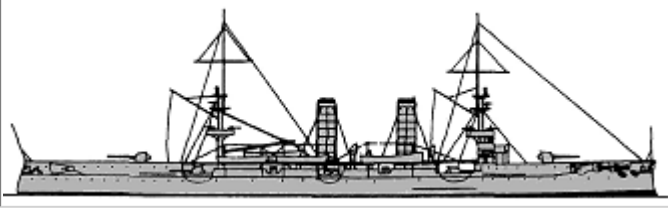
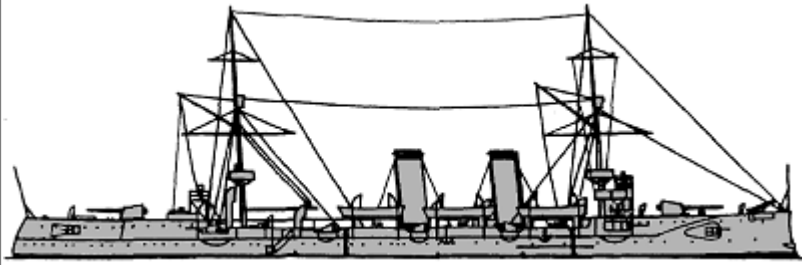
CL						
	Blanco Encalada	1 2	Blanco Encalada	1894		4568t, 112.8ppx14.2x5.6m, 8b,2vte, 14600hp, 22.8kts, 427p; Steel; 102slopes, 44deck, 152shields, 152CT; 2x1-203/40, 10x1-152/40, 5x1-76/40, 1x1-40/39
	Ministro Zenteno	1 3	Ministro Zenteno	1898		3437t, 100.6ppx13.3x5.1m, 8b,2vte, 7500hp, 20.2kts, 317p; Steel; 89slopes, 32deck, 102CT; 8x1-152/40, 10x1-57/40, 4x1-37/23, 3-450TT
	Chacabuco	1 4	Chacabuco	1902		4877t, 127.5x14.2x5.2m, 8b,2vte, 15700hp, 23kts, 400p; Harvey; 114slopes, 44deck, 114shields, 76CT; 2x1-203/45, 10x1-120/40, 12x1-76/40, 6x1-47/40, 3-450TT

TORPEDO SHIPS

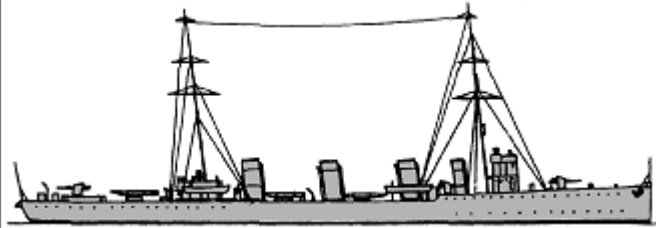
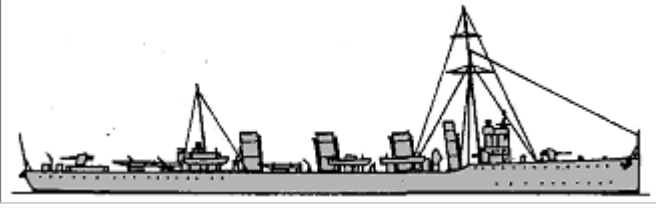
	Almirante Lynch	1	Almirante Lynch	1913		1850t, 100.8x9.9x3.4m, 6b,3t, 30000hp, 31kts, 160p; 6x1-102/40, 4x1-450TT
		2	Almirante Condell	1914		
DD	Almirante Williams	3	Almirante Williams	1915		1829t, 101.0x9.9x3.5m, 6b,3t, 30000hp, 31kts, 205p; 2x1-120/45, 2x1-102/45, 2x1-40/39, 2x2-533TT(3), 4x1-533TT(4,5)
		4	Almirante Uribe	1914		
		5	Almirante Riveros	1914		
	Serrano	6	Sargeno Aldea	1929		1430t, 91.4x8.8x3.9m, 3b,2gt, 28000hp, 35kts, 130p; 3x1-120/45, 1x1-76/40, 2x3-533TT, 2DCT, 20m(7,8,10), MS(6,9,11)
		7	Ingeniero Hyatt	1929		
		8	Capitán Orella	1928		
		9	Guardiamarina Riquelme	1929		





[home](#)[World navies yesterday](#)[1930](#)

# China 01 January 1930

## AIRCRAFT CARRYING SHIPS



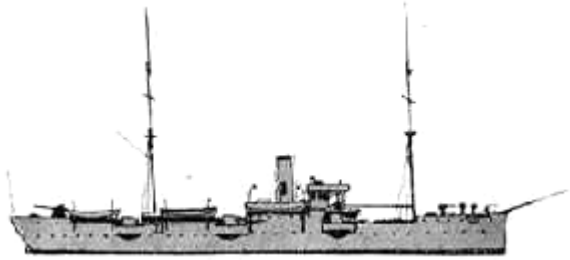

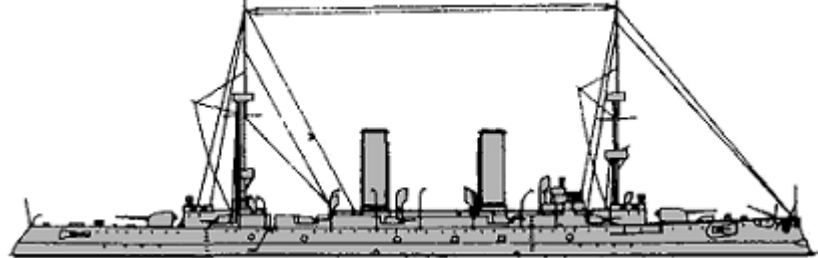
AV	Chen Hai	1	1	Chen Hai	1904	No picture	3000t, 77.2x11.4x4.0m, 1b,1vte, 136hp; 1x1-12/50, 4x1-76/50, 3seaplanes
	Wei Hai	1	2	Wei Hai	1897	No picture	2500t, 70.1x10.1x4.0m, 1b,1vte, 93hp; 2x1-76/50, 3seaplanes

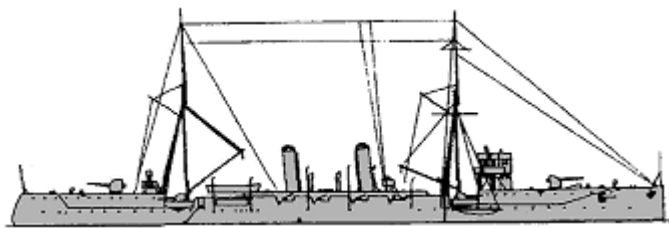
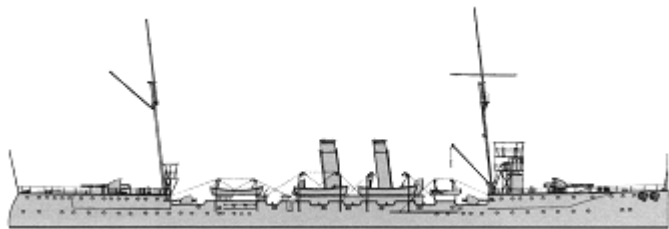
## CRUISERS

CL	Tung Chi	1	1	Tung Chi (TS)	1896		1900t, 77.0ppx10.4x4.9m, 4b,1vc, 1600hp, 11.6kts, 335p; 2x1-152/50, 5x1-120/45, 3x1-57/40, 8x1-37/23
	Hai Yung	3	2	Hai Yung	1898		2950t, 100.0x12.4x5.8m, 8b,2vte, 7500hp, 19.5kts, 244p; 32deck, 70slopes, 51shields, 37CT; 3x1-150/40, 8x1-105/40, 6x1-47/40, 3-356TT
			3	Hai Chou	1898		
		4	Hai Chen	1898			
	Hai Chi	1	5	Hai Chi	1899		4515t, 129.2x14.2x5.5m, 12b,4vte(2), 17000hp, 24kts, 350p; 37deck, 127slopes, 114gunhouses, 152CT; 2x1-203/45, 10x1-120/45, 12x1-47/40, 4x1-37/32, 5-450TT

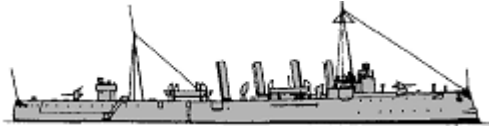
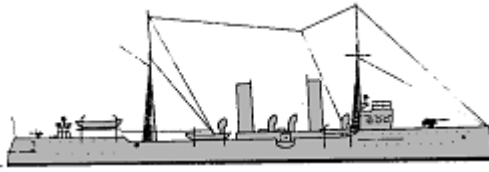
	Ying Swei	1	6	Ying Swei	1911		2500t, 105.0x11.9x4.0m, 6b,3t, 6000hp, 20kts, 270p; 25deck, 37slopes, 76CT; 2x1-152/50, 4x1-102/50, 4x1-76/50, 6x1-47/40, 2x1-37/32, 2x1-450TT
	Chao Ho	1	7	Chao Ho	1912		2750t, 105.5x12.8x4.5m, 8b,3t, 6000hp, 20kts, 283p; 25deck, 51slopes, 76CT; 2x1-152/50, 4x1-102/50, 4x1-76/50, 6x1-47/40, 2x1-37/32, 2x1-450TT

### TORPEDO SHIPS





PGT	Fei Ying	1	1	Fei Ying	1896		850t, 75.0x8.6x4.0m, 8b,2vte, 5430hp, 22kts, 90p; 25deck, 50shields; 2x1-105/40, 6x1-57/40, 4x1-37/23, (1+2x1)-356TT
	Chien Wei	2	2	Chien Wei	1903		900t, 79.2x8.1x3.5m, 4b,2vte, 6500hp, 20.5kts, 140p; 25belt, 25deck; 1x1-100/45, 3x1-65/60, 6x1-37/32, 2x1-356TT
3			Chien An	1903			
DD	Fu Po	3	1	Yu Chang	1911		390t, 60.4x6.5x1.8m, 4b,2vte, 6500hp, 32kts, 69p; 2x1-76/50, 2x1-47/40, 2x1-450TT
			2	Chien Kang	1912		
			3	Tung An	1912		
TB	Chang Tze	1	1	No3 Lieh Tze	1895	No picture	89t, 39.0x4.8x1.5m, 1b,1vc, 600hp, 18kts, 31p; 2x5-37/20, (2+1x1)-356TT
	Chen Tse	2	2	No2 Chen Tse	1896		126t, 43.9x5.2x2.4m, 2b,1vte, 1000hp, 18kts, 31p; 2x5-37/20, (2+1x1)-450TT
			3	No4 Su Tse	1896		
	Hu Peng	4	4	No7 Hu Peng	1906		120t, 41.1x4.9x2.1m, 2b,1vte, 1200hp, 23kts, 34p; 2x1-47/40, (1+2x1)-450TT
			5	No8 Hu Oah	1906		
			6	No9 Hu Ying	1907		
			7	No10 Hu Chen	1907		

### ESCORTS

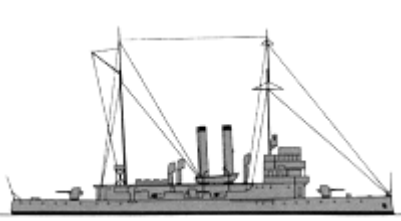

Yi Sheng	2	1	Yi Sheng	1911		350(1)-300(2)t, 36.791)-38.1(2)x6.3(1)-6.4(2)x3.4(1)-2.1(2)m, 1b,1vte, 500hp, 10kts, 37(1)-42(2)p; 1x1-76/50(2), 1x1-65/60(1), 1x1-57/40
		2	Yung Sheng	1928		
Hai Yen	1	3	Hai Yen	1917	No picture	60t, 19.8x3.7x0.7m, 1b,2vte, 60hp, 10kts; 1x1-37/32
		4	Hai Ku	1917		

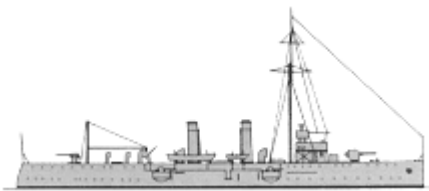
PC	Hai Ku	2	5	Hai Hung	1917		200t, 34.1x5.5x2.6m, 1b,2vte, 300hp, 10.5kts, 22p; 2x1-37/32
			6	Hai Fu	1917		166t, 33.2x5.2x2.4m, 1b,1vte, 220hp, 10.5kts, 22p; 1x1-37/32
	7	Hai Ou	1917				
	Hai Hao	2	8	Hai Hao	1917		230t, 32.3x5.5x2.0m, 1b,1vte, 200hp, 12kts, 22p; 4x1-37/32
9			Hai Peng	1920			
	Shun Sheng	1	10	Shun Sheng	1928		350t, 44.5x7.5x1.8m, 1b,1vte, 500hp, 10.7kts, 65p; 2x1-76/40, 2x1-37/32

## OTHER FIGHTING SHIPS

PG	Kiang Yuan	3	1	Kiang Yuan	1905		565t, 54.1x8.5x2.1m, 2b,2vte, 950hp, 13kts, 85p; 1x1-120/40, 1x1-76/40, 4x1-47/40
			2	Kiang Li	1907		
			3	Kiang Chen	1907		
	Chu Tung	6	4	Chu Tung	1906		752t, 61.0x9.0x2.4m, 2b,2vte, 1350hp, 13kts, 117p; 2x1-120/40, 2x1-76/40
			5	Chu Chien	1906		
			6	Chu Tai	1906		
			7	Chu Yu	1907		
			8	Chu Yiu	1907		
	Lien Ching	1	10	Lien Ching	1911	No picture	500t, 53.3x7.6x2.9m, 2b,2vte, 925hp, 13.5kts, 60p; 4x1-47/40
			11	Wu feng	1912	No picture	200t, 37.8x6.1x2.1m, 1b,1vte, 300hp, 10kts, 46p; 2x1-65/60
	Yung Feng	2	12	Chung Shan	1913		1020t, 65.8x9.0x2.4m, 2b,2vte, 1350hp, 13kts, 108p; 25deck; 1x1-105/40, 1x1-76/50, 4x1-47/40, 2x1-37/32
			13	Yung Hsiang	1913		
	Yung Chien	2	14	Yung Chien	1915		1039t, 65.7x9.0x3.5m, 2b,2vte, 1350hp, 13kts, 105p; 25deck; 1x1-102/40, 1x1-76/40, 4x1-47/40, 2x1-37/32
			15	Yung Chi	1916		
	Hsien Ning	1	16	Hsien Ning	1929		500t, 54.9x7.3x2.0m, 2b,2vte, 2500hp, 17kts, 115p; 1x1-120/45, 1x1-102/45, 3x1-57/40, 1x1-47/50

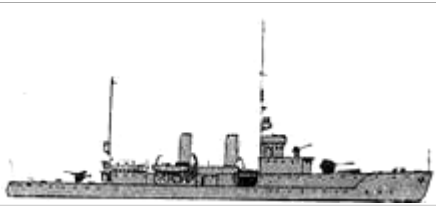
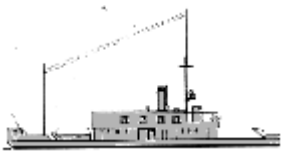
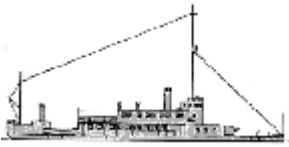

	Yung Sui	1	17	Yung Sui	1929		800t, 68.0ppx9.1x1.8m, 2b,2vte, 4000hp, 18.5kts, 100p; 1x1-152/50, 1x1-120/45, 3x1-76/40, 4x1-57/40, 1x1-40/39
APC	-	1	1	Ting Hai	1896		2500t, 73.0x10.5xm, 1vte, 127hp, 13kts; 2x1-120/45, 2x1-76/50, 20m
PR	Chiang Kung	4	1	Chiang Kung	1909		200t, 44.0x6.0x1.6m, 1b,2vte, 500hp, 14kts, 62p; 1x1-76/40
			2	Chiang Chi	1909		
			3	Chiang Ku	1909		
			4	Chiang Tai	1909		
	Chiang Hsi	2	5	Chiang Hsi	1912		140t, 43.9(5)-44.5(6)x7.5(5)-7.3(6)x0.6m, 2b,2vte, 450(5)-500(6)hp, 12kts, 49p; 1x1-88/22
			6	Chiang Kun	1912		
	Chien Chung	3	7 - 9	Chien Chung, Yung An, Kung Chen	1915 - 1916	No picture	90t, 35.5x5.6x0.6m, 1b,2vte, 450hp, 11kts, 42p; 1x1-88/22
	Li Sui	1	10	Li Sui	1904		280t, 50.1x8.0x0.9m, 2b,2vte, 1300hp, 13kts, 58p; 1x1-88/30, 1x1-50/40
	Chung Yun	2	11, 12	Chung Yun, Chung Hai	1928	No picture	60t, 25.6x4.5x0.8m, 1b,1vte, 100hp, 10.5kts, 31p; 4x1-37/32
	Chien Yu	2	13	Chien Yu	1929	No picture	225t, 36.8x6.5x1.3m, 1b,2vte, 400hp, 10.5kts, 52p; 1x1-57/40, 2x1-40/39
14			Chien Shun	1929			

## COASTAL FORCES

PT	Kuai 1	2	1, 2	Kuai 1, 2	1918		13t, 16.4x2.9x1.4m, 2pe, 500hp, 26kts, 8p; 2-450TT, 1DCR
----	--------	---	------	-----------	------	--	--



[home](#)[World navies yesterday](#)[1930](#)

## Colombia 01 January 1930

### OTHER FIGHTING SHIPS

PG	Carabobo	3	1	Carabobo	1925	No picture	120t, 33.0x6.0x2.5m, 1b,1vte, 300hp, 13kts, 37p; 1x1-75/35, 1x1-37/50
			2	Boyaca	1925		
			3	Pichincha	1925		
PGR	Esperanza	2	1	Esperanza	1897	No picture	400t, 42.4ppx5.8x0.9m, sw, 430hp, 15kts; 3x1-37/23
			2	General Nerino	1895		
	Chercinto	1	3	Chercinto	1896	No picture	643t, 56.4x9.4x3.7m, 400hp, 12kts; 3x1-37/23
APGR	-	1	1	Colombia	1912		230t; 1x1-76/40

### COASTAL FORCES

YPR	No1	4	1-4	No1-4	1913	No picture	20t, 24.0x3.8x1.2m, pe, 160hp, 12kts, 6p; 1x1-37/32
-----	-----	---	-----	-------	------	------------	---

© Ivan Gogin, 2011-15

[home](#)[World navies yesterday](#)[1930](#)

# Cuba 01 January 1930

## OTHER FIGHTING SHIPS

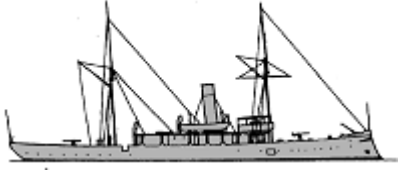
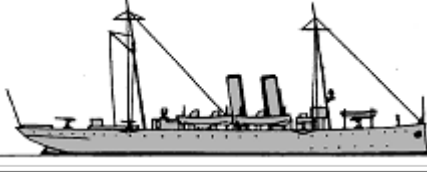
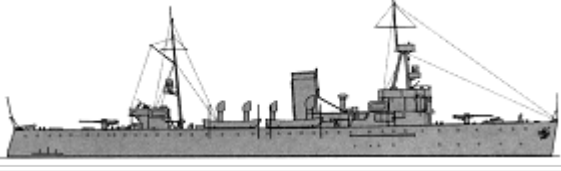
PG	Baire	1	1	Baire	1906		510t, 59.7x7.0x2.7m, 1vte, 1200hp, 14kts, 76p; 4x1-76/50, 2x1-37/40
	Santa Clara	1	2	Santa Clara	1911	No picture	52t, 32.0x1.8m, 12kts, 17p; 1x1-37/40
	Diez de Octubre	2	3	Diez de Octubre	1911	No picture	218t, 33.6x6.1x2.4m, 1vte, 12kts, 39p; 3x1-47/40
			4	Veinte y Cuatro de Febrero	1911		
	Patria	1	5	Patria	1911		1200t, 61.0ppx11.0x4.0m, 2vte, 4000hp, 16kts, 115p; 4x1-57/40, 4x1-47/40
	Cuba	1	6	Cuba	1911		2055t, 79.2x11.9x4.3m, 2vte, 6000hp, 18kts, 145p; 2x1-102/50, 4x1-57/40, 4x1-47/40, 4x1-37/40
	Habana	2	7,8	Habana, Pinar del Río	1912	No picture	80t, 30.5x5.5x1.3m, 1vte, 200hp, 12kts, 20p; 1x1-37/40
General Juan Bruno Zayas	1	9	General Juan Bruno Zayas	1914	No picture	300t, 50.0x3.4m, 11kts, 51p; 2x1-37/40	

## COASTAL FORCES

SC	CS1	4	1-4	CS1-4	1918		85t, 33.5x4.5x1.7m, 3pe, 660hp, 18kts, 27p; 1x1-76/23, 1DCT
----	-----	---	-----	-------	------	---	---

## COAST GUARD SHIPS

CGS	Veinte de Mayo	1	1	Veynte de Mayo	1895	No picture	203t, 45.7x5.6x3.2m, 500hp, 12kts, 43p; 2x1-47/40, 2x1-37/40
	Yara	1	2	Yara	1895	No picture	449t, 47.2x7.9x4.0m, 600hp, 12kts, 53p; 2x1-57/40, 2x1-47/40
	Alfredo	1	3	Alfredo	1896	No picture	40t, 18.3x3.7x1.8m, 11kts; 1x1-37/40
	Maceo	1	4	Maceo	1896	No picture	35t, 22.9x3.1x1.7m, 10kts; 1x1-37/40
	Enrique Villuendas	1	5	Enrique Villuendas	1899	No picture	178t, 40.2x6.1x2.7m, 600hp, 16kts; 2x1-47/40
	Matanzas	2	6,7	Matanzas, Las Villas	1912	No pictures	80t, 30.5x5.5x1.3m, 1vte, 200hp, 12kts, 20p; 1x1-37/40

© Ivan Gogin, 2012-15

[home](#)[World navies yesterday](#)[1930](#)

## Czechoslovakia 01 January 1930

### RIVER BOATS

PGR	Md-1	2	1, 2	OMd1, 2	1920		35t, 21.0x4.0x1.6m, 1d, 225hp, 10.8kts, 43p; 2x1-75/15, 10m
YPR	OMh3	3	1-3	OMh3-5	1924		24t, 16.9x2.8x0.8m, 1pe, 100hp, 10.8kts, 9p

### MINE WARFARE BOATS

MLBR	Ms-5	2	1, 2	OMm33, 34	1920		24t, 16.9x2.8x0.8m, 1d, 100hp, 10.8kts, 6p; 7m
------	------	---	------	-----------	------	---	--

© Ivan Gogin, 2011-15

[home](#)[World navies yesterday](#)[1930](#)

## DENMARK 01 January 1930

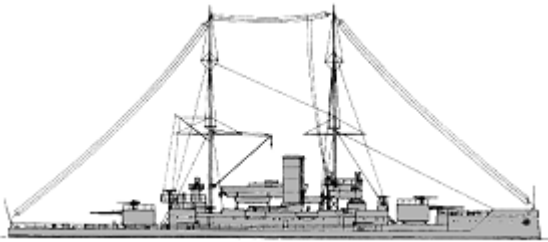
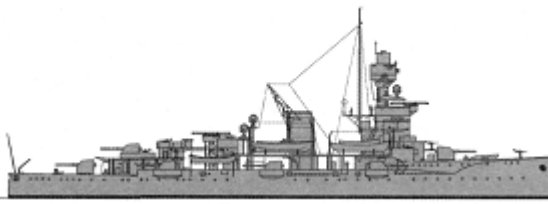

### CAPITAL SHIPS

BC	Herluf Trolle	1	Herluf Trolle	1901		3650(1)-3700(2)-3785(3)t, 86.5(1, 2)-87.4(3)x15.1(1)-15.4(2)-15.7(3)x4.9(1)-5.0(2, 3)m, 6b, 2vte, 4200(1, 2)-5400(3)hp, 15.5(1, 2)-16(3)kts, 258p; s(1)-k(2, 3): 195belt, 65deck, 175(1)-190(2, 3)turrets, 190CT; 2x1-240/40(1), 2x1-240/43(2, 3), 4x1-150/43(1, 2), 4x1-150/50(3), 6x1-75/55(1, 2), 10x1-75/55(3), 2x1-57/44(1, 2), 8x1-37/23(1), 2x1-37/23(3), 3-450TT(1, 2), 4-450TT(3)
		2	Olfert Fischer	1905		
		3	Peder Skram	1908		
	Niels Iuel	1	4	Niels Iuel	1923	

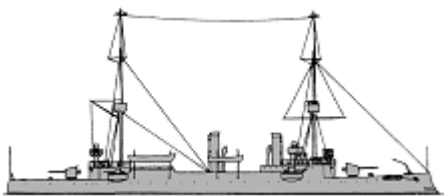
### CRUISERS



CL	Gejser	1	1	Hejmdal	1895		1342t, 72.3x10.4x3.6m, 8b, 2vte, 3000hp, 17kts, 156p; s: 45deck; 2x1-120/40, 4x1-87/40, 4x1-57/44, 1-450TT, 3-381TT
----	--------	---	---	---------	------	--	---

### TORPEDO SHIPS



	Ormen	1	1	Ormen	1907		105t, 38.0x4.3x2.6m, 2b, 1vte, 2100hp, 26.2kts, 21p; 2x1-37/23, (1+1x2)-450TT
	Tumleren	3	2	Tumleren	1911		271t, 56.4x5.8x2.2m, 2b, 1t, 5000hp, 27.5kts, 33p; 2x1-75/55, (1+4x1)-450TT
			3	Vindhunden	1912		
			4	Spækhuggeren	1912		

TB	Søridderen	3	5	Søridderen	1911		295t, 55.4x5.5x2.0m, 2b, 1t, 5000hp, 27.5kts, 33p; 2x1-75/55, (1+4x1)-450TT
			6	Flyvefisken	1911		
			7	Sølulven	1911		
	Springeren	4	8	Makrelen	1918		109t, 38.5x4.3x2.7m, 2b, 1vte, 2000hp, 24.6kts, 24p; 2x1-57/44, (1+1x1)-450TT
			9	Nordkaperen	1918		
			10	Havkatten	1920		
			11	Sælen	1920		

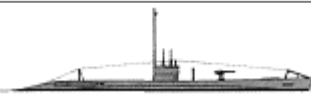

## SUBMARINES

SS	Havmanden	3	1	Havfruen	1913		164/204t, 38.3x3.6x2.3m, 1d/em, 450/275hp, 13/10kts, 10p; 2-450TT
			2	Najaden	1913		
			3	Nymfen	1914		
	Ægir	5	4	Ægir	1915		185/235t, 40.6x3.7x2.4m, 2d/2em(1), 450/340hp, 13.5/9.8kts, 11p; 1x1-57/44, 3-450TT
			5	Ran	1915		
			6	Triton	1916		
			7	Neptun	1916		
			8	Galathea	1917		
	Rota	3	9	Rota	1920		301/369t, 47.5x4.8x2.7m, 2d/em, 900/640hp, 14.5/10.5kts, 17p; 1x1-57/44, 4-450TT
			10	Bellona	1921		
			11	Flora	1922		
	Daphne	2	12	Daphne	1926		308/381t, 49.0x5.2x2.5m, 2d/em, 900/400hp, 13.4/6.8kts, 24p; 1x1-75/35, 1x1-20/60, 6-450TT
			13	Dryaden	1927		

## ESCORTS

FPV	Beskytteren	1	1	Beskytteren	1900	No picture	415t, 43.4x7.6x3.8m, 2b, 1vte, 625hp, 11kts, 47p; 1x1-47/44, 2x1-37/23
	-	1	2	Fenris	1915		148t
	Islands Falk	1	3	Islands Falk	1906	No picture	760t, 56.0x8.9x5.2m, 2b, 1vte, 1100hp, 13kts, 63p; 2x1-75/55, 2x1-47/44
	Diana	1	4	Diana	1917	No picture	288t, 35.5x6.6x3.0m, 400hp, 10.5kts, 27p; 2x1-47/44
	Hvidbjørnen	1	5	Hvidbjørnen	1929		1050t, 63.2x9.7x5.2m, 1b, 1vte, 1800hp, 14.5kts, 58p; 2x1-87/50, 1seaplane (1 H.E.8)
PC	Nr.8	1	1	P8	1894	No picture	48t, 25.6x3.8x1.8m, 1b, 1vte, 330hp, 25p; 1x1-47/44, 1x5-37/23, 1x1-356TT
	Hvalrossen	3	2	Hvalrossen	1913		182t, 45.2x5.2x2.2m, 2b, 2vte, 3500hp, 26.3kts, 30p; 1x1-75/55, (1+1x2+1x1)-450TT
			3	Delfinen	1914		
			4	Sværdfisken	1914		

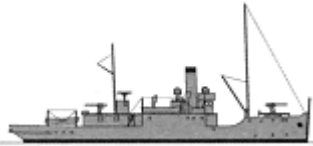
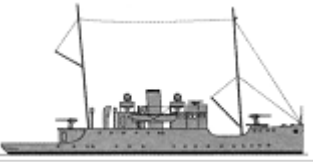
## MINE WARFARE

ML	Lossen	1	1	Lossen	1911		640t, 48.6x8.5x3.1m, 2b, 2vte, 900hp, 13kts, 53p; 2x1-57/44, 180mines
	Minekran Nr.V	2	2	Minekran Nr.V	1917	No picture	186t, 27.0x6.3x2.0m, 2dg, 2em, 290hp, 8kts, 26p; 2x1-37/38, 60mines
			3	Minekran Nr.VI	1919		
Henrik Gerner	1	4	Henrik Gerner	1928		463t, 49.0x6.2x2.4m, 2d, 900hp, 13.2kts, 45p; 2x1-75/55, 80mines	
MS	Springeren	6	1	Springeren	1917		109t, 38.5x4.3x2.7m, 2b, 1vte, 2000hp, 24.6kts, 24p; 2x1-57/44, 1-450TT, MS
			2	Støren	1917		
			3	Søløven	1917		
			4	Søhunden	1917		
			5	Havhesten	1917		
			6	Narhvalen	1917		

[home](#)[World navies yesterday](#)[1930](#)

## Ecuador 01 January 1930

### TORPEDO SHIPS

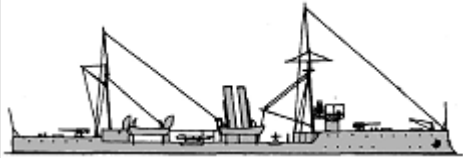
PGT	Libertador Bolívar	1	1	Libertador Bolívar	1896		800t, 73.2x8.4x4.3m, 4b,2vte, 4500hp, 21.5kts; steel; 25side, 25deck, 25CT; 2x1-120/40, 4x1-47/40, (1+2x1)-450TT
-----	--------------------	---	---	--------------------	------	--	--

### OTHER FIGHTING SHIPS

APG	-	1	1	Cotopaxi	1884		300t; 4x1-76/40
DV	Atahualpa	1	1	Atahualpa	1927	No picture	100t, 1vte; 1x1-47/40

© Ivan Gogin, 2012-15



[home](#)[World navies yesterday](#)[1930](#)

## Egypt 01 January 1930

### ESCORTS

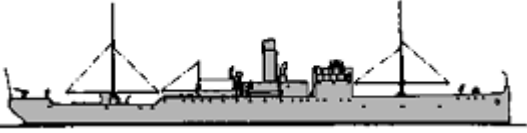
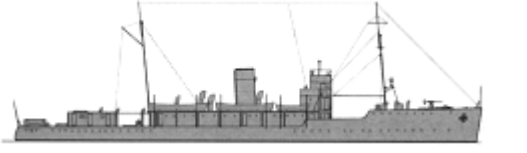
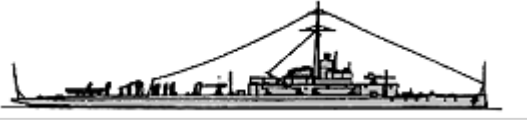
SL	Sollum	1	1	Sollum	1917		1493t, 80.0x10.7x3.5m, 2b,1vte, 2500hp, 17.5kts, 77p; 1x1-76/40
	El Amir Farouq	1	2	El Amir Farouq	1926		1441t, 75.3x10.4x4.0m, 2b,2vte, 2800hp, 17kts, 70p; 1x1-57/40
FS	Raqib	1	1	Raqib	1917		613t, 74.5x7.2x2.4m, 2b,2t, 3500hp, 20kts, 54p; 1x1-102/40, 1x1-40/39, 2x1-356TT, 2DCR

### OTHER FIGHTING SHIPS

PGR	Tamai	2	1, 2	Hafir, Abu Klea	1884-1885	No picture	74t, sw; 1x1-76/40
	El Zafir	3	3	El Zafir	1896/97	No picture	128t, sw; 1x1-76/40
			4	El Fateh	1896/97		
			5	El Nasir	1896/97		
	Sheik	1	6	Melik	1896/97	No picture	140t, 1vte; 1x1-76/40

### COASTAL FORCES

YP	Darfeel	2	1, 2	Darfeel, Noor El Bahr	1925	No picture	20t, 17.1xxm, 330hp, 17kts; 1x1-37/37
----	---------	---	------	-----------------------	------	------------	---------------------------------------

© Ivan Gogin, 2011-15



[home](#)

[World navies yesterday](#)

[1930](#)

# Estonia 01 January 1930

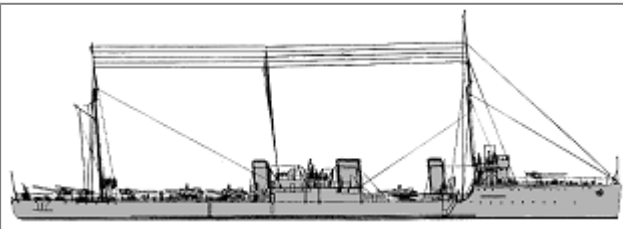
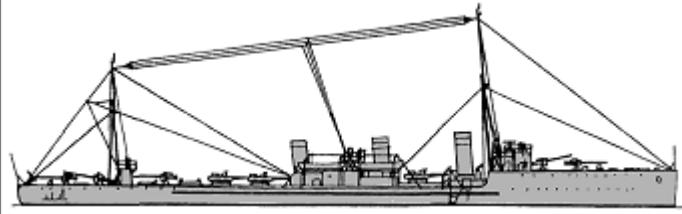
## TORPEDO SHIPS



DD	Wambola	1	1	Wambola	1917		1450t, 98.0x9.3x3.9m, 4b,2t, 31500hp, 34kts, 150p; 4x1-102/60, 1x1-40/39, 3x3-450TT, 80m
	Lennuk	1	2	Lennuk	1917		1570t, 107.0x9.5x4.1m, 5b,2t, 32700hp, 35kts, 150p; 5x1-102/60, 1x1-76/30, 3x3-450TT, 80m
TB	Sulev	1	1	Sulev	1916		286t, 50.0x5.3x2.3m, 1b,1gt, 3250hp, 24kts, 35p; 2x1-75/50, 1x2-450TT, 10m

## OTHER FIGHTING SHIPS

PG	Laine	1	1	Laine	1913		211t, 37.0x6.1x1.8m, 1b,1vte, 500hp, 12kts, 20p; 2x1-76/30
APGR	-	3	1	Ahti	1908		115t
			2	Mardus	1911		150t; 2x1-75/50
			3	Tartu	1897		110t

## MINE WARFARE SHIPS

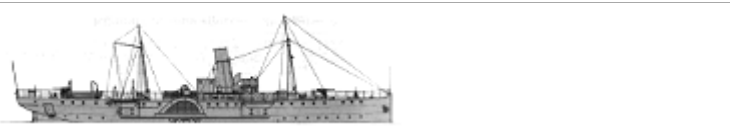
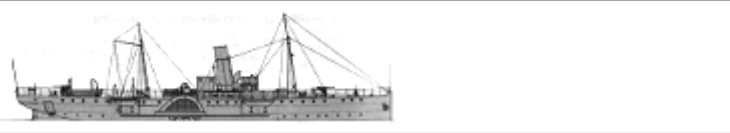
--	--	--	--	--	--	--	--

AML	-	2	1	Ristna	1906		600t; 175m
			2	Suurop	1906		600t; 175m
MSB	Kalev	1	1	Kalev	1914		34t, 20.7x5.0x1.2m, 2sd, 60hp, 7.2kts, 8p; 25m, MS
	Olev	1	2	Olev	1916		46t, 23.2x5.0x1.1m, 2sd, 60hp, 7.2kts, 8p; 40m, MS

## BOARD GUARD SHIPS

ABGS	-	1	1	Kou	1909		100t
------	---	---	---	-----	------	--	------

© Ivan Gogin, 2011-15

[home](#)[World navies yesterday](#)[1930](#)

## Finland 01 January 1930

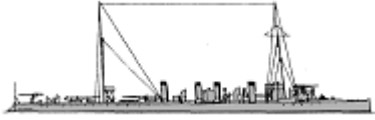

### TORPEDO SHIPS

DD	S1	2	1	S1	1902		305t, 58.5(1)-57.9(2,3)x5.7x2.3m, 4b(1,2)-8b(3),2vte, 3800hp, 27kts, 58p; 2x1-75/50, 10m, MS
			2	S5	1902		

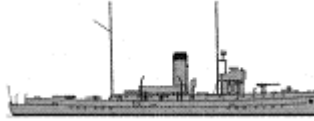

### ESCORTS

PC	Klas Horn	2	1	Klas Horn	1892		432t, 60.2x7.4x3.3m, 2b,1vte, 3500hp, 22kts, 65p; 2x1-102/60(1), 2x1-75/50(2)
			2	Matti Kurki	1892		





### OTHER FIGHTING SHIPS

PG	Karjala	2	1	Karjala	1918		342t, 50.1x6.8x2.3m, 2b,2vte, 1150hp, 15kts, 48p; 2x1-75/50, 1x1-40/39, 30m
			2	Turunmaa	1918		
	Hämeenmaa	2	3	Hämeenmaa	1918		530t, 52.0x7.5x3.4m, 3b,2vte, 1400hp, 15kts, 55p; 2x1-102/60, 1x1-40/39
			4	Uusimaa	1918		

### COASTAL FORCES

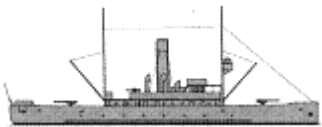
PT	MTV1	2	1, 2	MTV1, 2	1918		13t, 16.4x2.8x1.4m, 2pe/em, 500/10hp, 26.5kts, 8p; 2-450TT
	MTV3	1	3	MTV3	1926		11t, 16.6x3.4x1.1m, 2pe, 600hp, 31kts, 5p; 2-450TT
	MTV4	4	4-7	MTV4-7	1928-1929		12t, 16.8x3.4x1.0m, 2pe/1pe(2), 750/25hp, 40kts, 7p; 2-450TT

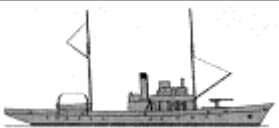
## MINE WARFARE SHIPS AND CRAFTS

ML	M1	1	1	M1	1916		776t, 50.0x8.0x2.7m, 3b,1vte, 800hp, 12kts, 46p; 2x1-75/50, 150m
MLB	T15	3	1-3	T15, 16, 21	1914		60t, 20.7x5.0x1.2m, 2sd, 60hp, 7.2kts, 8p; 30m
	T17	2	4, 5	T17, 22	1916		80t, 23.2x5.0x1.1m, 2sd, 60hp, 7.2kts, 8p; 45m
MS	T1	2	1	T1	1918		220t, 43.6x6.1x1.7m, 2b,2vte, 400hp, 11kts, 35p; 1x1-75/50, 1x1-47/43, MS
			2	T2	1917		
MSB	A8	27	1-27	A8, 9, 11-21, 24, 35-45, MP1, 5	1916 - 1917	No picture	20t, 19.8x3.6x1.2m, 1pe, 10kts; MS
	AF1	5	28-32	AF1-5	1917 - 1918		25t, 15.3x3.5xm, 1pe, 50hp, 9kts, 8p; MS
	BVA	4	33-36	BVA, BVB, BVC, BVD	1910		25t, 22.2x3.1x0.5m, 2pe, 200hp, 14.5kts, 12p; 8belt, 8deck, 8CT; 1x1-76/16, MS

[home](#)[World navies yesterday](#)[1930](#)

## France 01 January 1930

*IN SERVICE: 3 battleships-predreadnoughts, 6 battleships, 1 fleet aircraft carrier, 8 armoured cruisers, 2 heavy cruisers, 7 light cruisers, 63 destroyers, 3 torpedo boats, 54 submarines, 7 sloops, 62 anti-submarine ships, 29 submarine chasers, 43 patrol trawlers and tugs, 6 river gunboats, 7 motor torpedo boats, 2 auxiliary minelayers, 12 minesweepers, 1 armed trawler*

### CAPITAL SHIPS

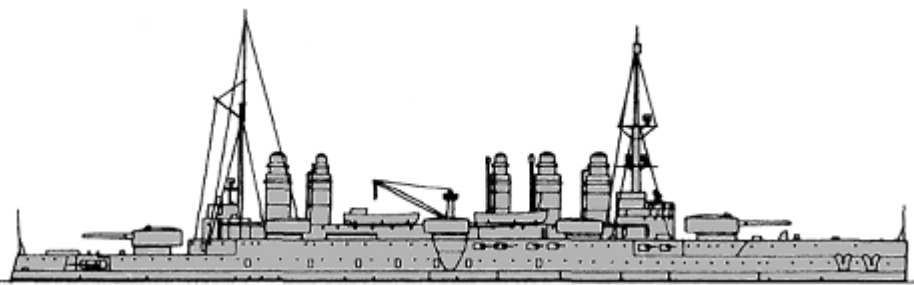
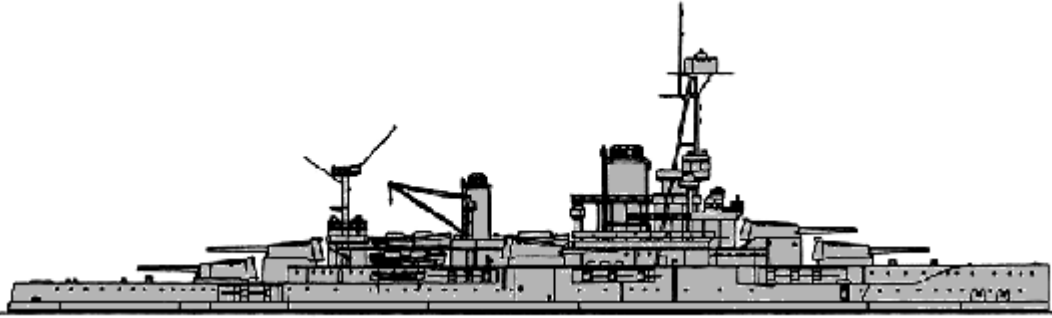
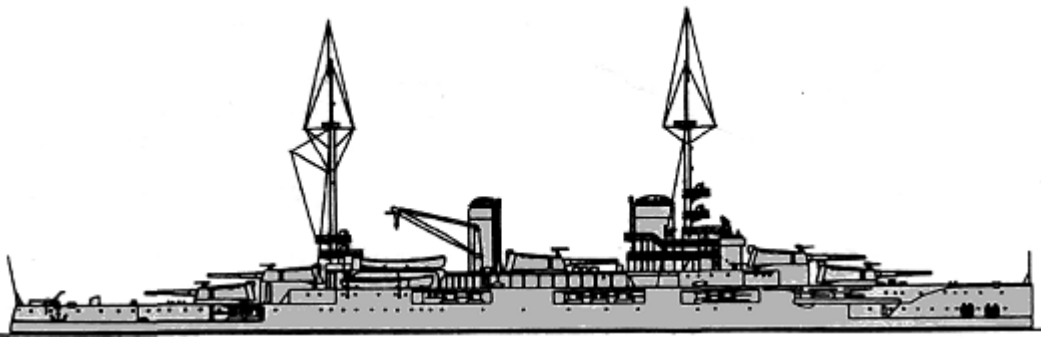
Danton	3	1	Condorcet (TS)	1911		19763t, 146.6x25.8x9.2m, 26b,4t, 22500hp, 19.2kts, 921p; 270belt, (48+45)deck, 300turrets, 300CT; 2x2-305/45, 6x2-240/50, 28x1-75/65, 10x1-47/50, 2-450TT	
		2	Diderot (TS)	1911			
		3	Voltaire (TS)	1911			
BB	Courbet	3	4	Courbet	1913		26000t, 168.0x27.9x9.0m, 26b,4t, 28000hp, 20kts, 1108p; 270belt, (70+40)deck, 320turrets, 300CT; 6x2-305/45, 22x1-139/55, 4x1-75/50(5,6), 4x1-47/50, 4-450TT
			5	Jean Bart	1913		
		6	Paris	1914			
Bretagne	3	7	Bretagne	1915		25000t, 166.0x26.9x9.8m, 24b(7,9)-18b(8),4t, 29000hp, 20kts, 1133p; 250belt, (45+40)deck, 400-250turrets, 300CT; 5x2-340/45, 18x1-139/55, 4x1-75/65, 4x1-47/50, 4-450TT, 30m	
		8	Provence	1915			
		9	Lorraine	1916			

## AIRCRAFT CARRYING SHIPS

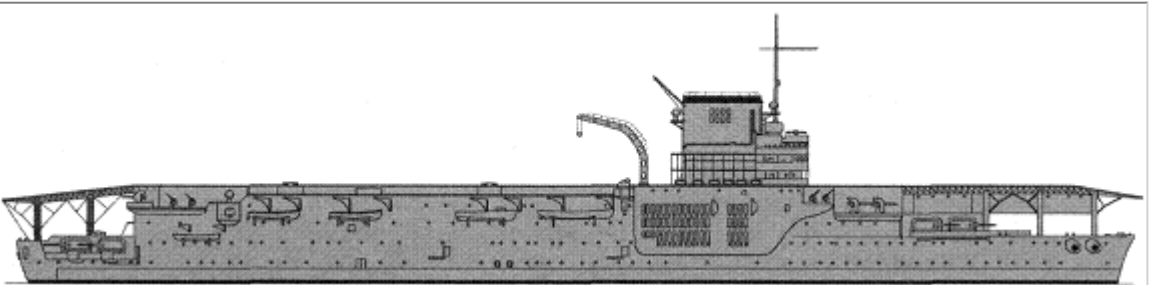
CV	Béarn	1	1	Béarn	1927		28400t, 182.6x31.0x9.3m, 6b,2t,2vte(4), 37500hp, 21.5kts, 865p; 80belt, (24+24+60)deck, 70casemates; 8x1-155/50, 6x1-75/50, 4-550TT, 40aircraft (20 D.1, 5 P.L.2)
----	-------	---	---	-------	------	--	---

## CRUISERS

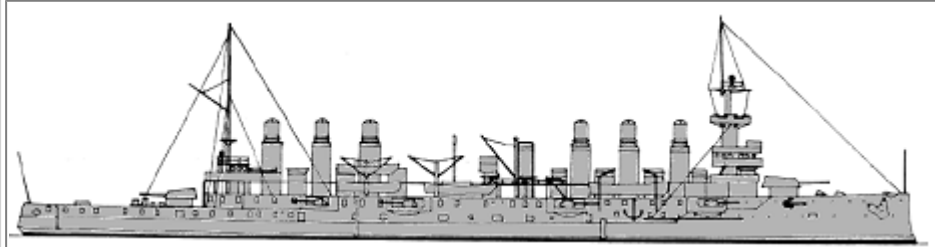
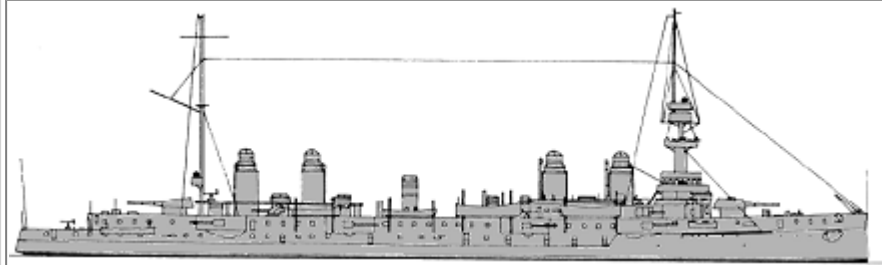
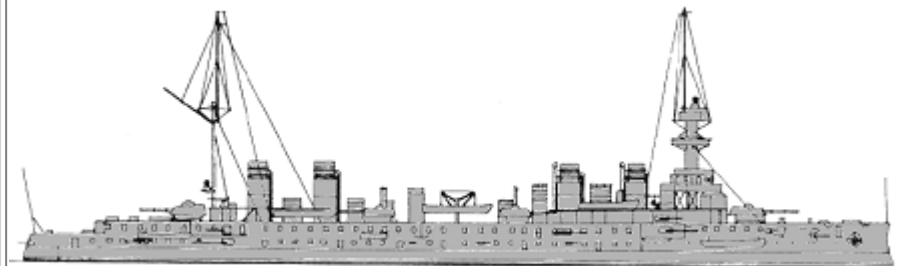
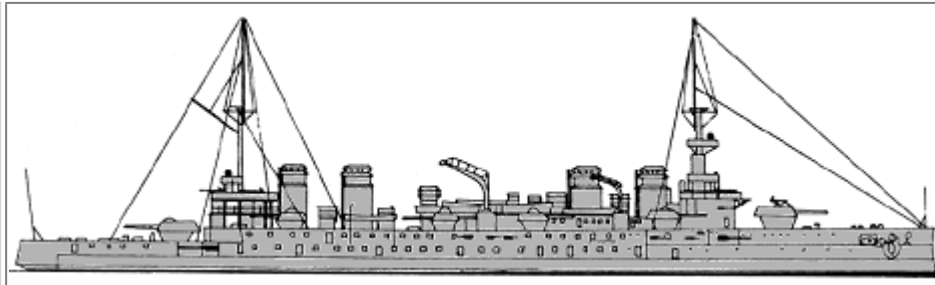

	Jeanne d'Arc	1	1	Jeanne d'Arc II	1903		11092t, 145.4x19.4x8.1m, 36b,3vte, 33000hp, 21.8kts, 651p; h: 150belt, 65deck, 160turrets, 150CT; 2x1-194/40, 14x1-139/45, 16x1-47/40, 6x1-37/23, 2-450TT
	Gueydon	1	2	Gueydon (TS)	1903		9548t, 138.0x19.4x7.7m, 28b,3vte, 19600hp, 21kts, 566p; h: 150belt, 55deck, 200turrets, 160CT; 2x1-194/40, 8x1-164/45, 4x1-100/45, 16x1-47/40, 4x1-37/23, 2-450TT
	Gloire	1	3	Condé	1904		10212t, 139.8x20.2x7.7m, 28b,3vte, 21800hp, 21.5kts, 615p; h: 150belt, (46+36)deck, 173turrets, 150CT; 2x1-194/40, 8x1-164/45, 6x1-100/45, 18x1-47/40, 2-450TT
CA	Jules Michelet	1	4	Jules Michelet	1908		13105t, 146.5x21.4x8.4m, 28b,3vte, 30000hp, 22.5kts, 770p; 150belt, (65+35)deck, 200turrets, 200CT; 2x2-194/50, 12x1-164/45, 16x1-47/50, 2-450TT
	Ernest			Ernest			13504t, 159.0x21.3x8.4m, 42b,3vte, 36000hp, 23kts, 824p; 150belt, (65+35)deck, 200turrets, 200CT; 2x2-194/50, 12x1-

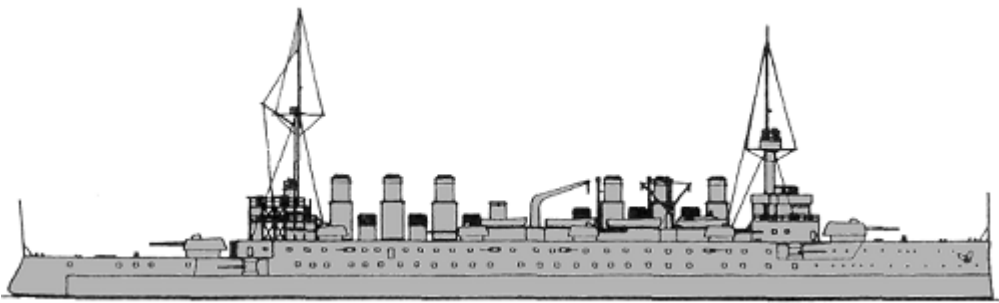
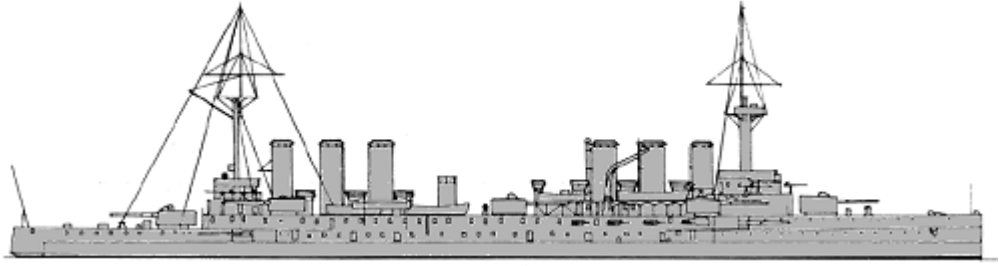
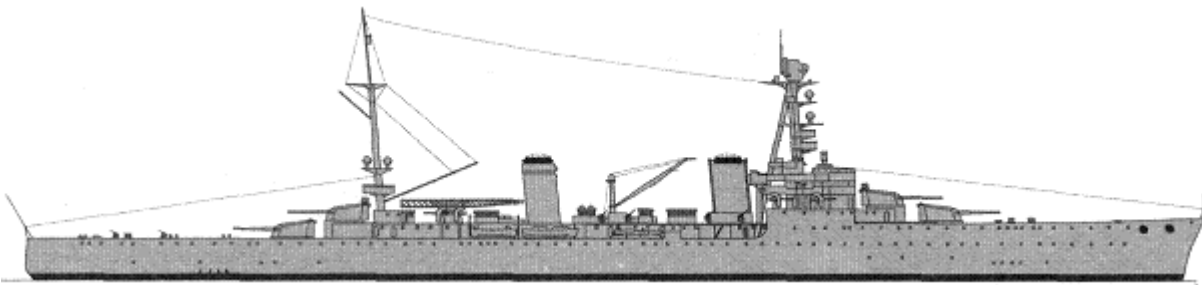
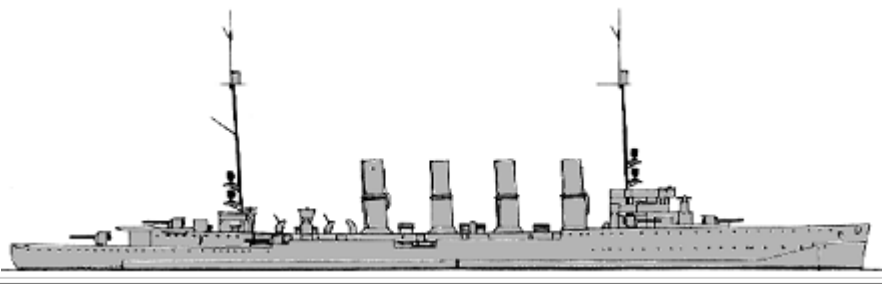
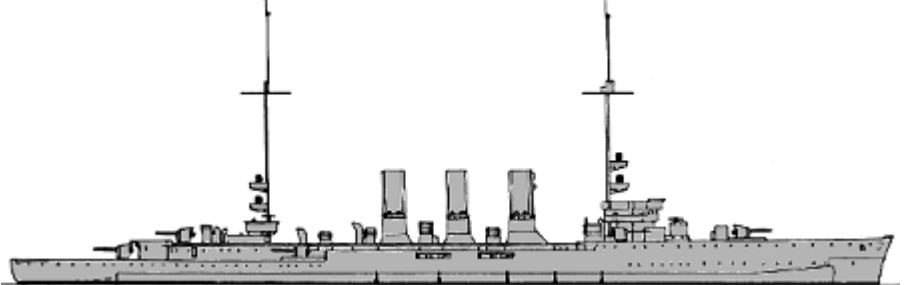
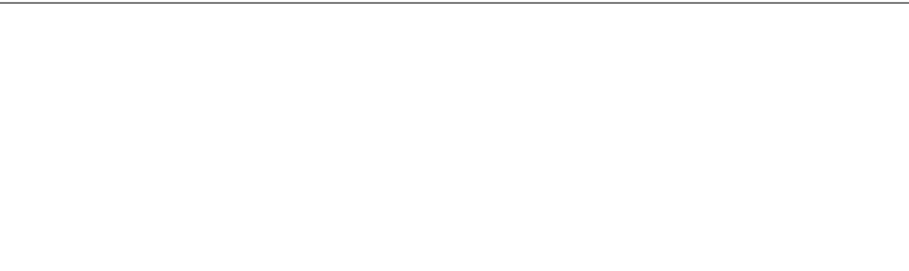

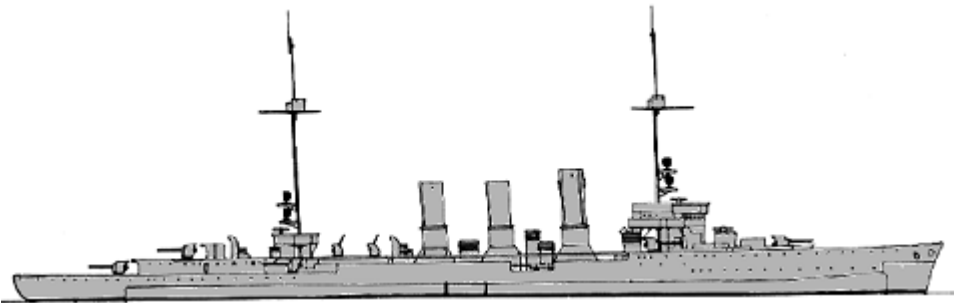
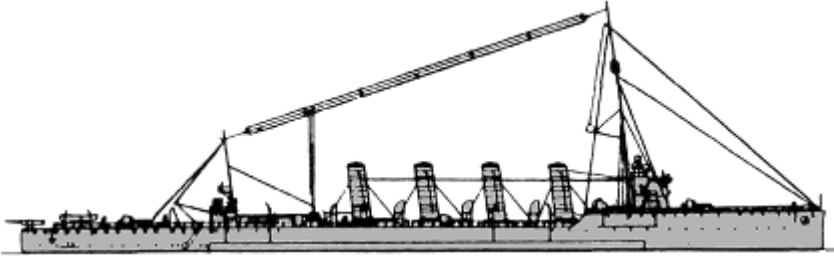
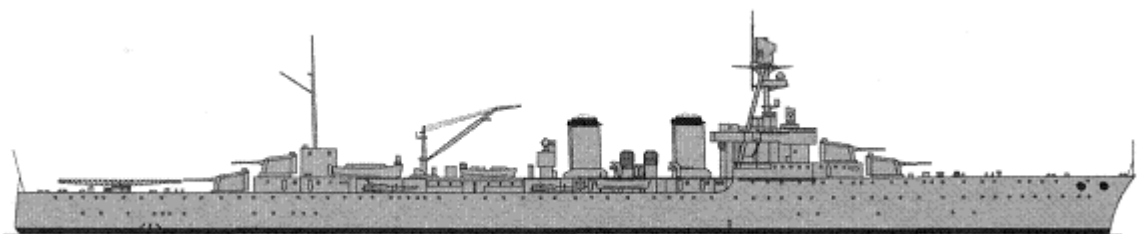

	Renan	1	5	Renan (TS)	1909		164/45, 18x1-65/50, 8x1-47/50, 2x1-37/23, 2-450TT, 1 seaplane (FBA.17)
Edgar Quinet	2	6	Edgar Quinet (TS)	1911		13847(6)-13995(7)t, 158.9x221.5x8.4m, 24b(6)-42b(7),3vte, 24000(6)-36000(7)hp, 18(6)-23(7)kts, 892p; 150belt, (65+35)deck, 200turrets, 200CT; (2x2+6x1)-194/50(6), (2x2+10x1)-194/50(7), 22x1-65/50, 4x1-47/50, 2-450TT, 2seaplanes (FBA.17)(6)	
		7	Waldeck- Rousseau	1911			
Duquesne	2	8	Duquesne	1927		12200t, 191.0x19.0x6.3m, 9b,4gt, 12000hp, 33.7kts, 605p; 30magazines, 24deck, 30turrets, 30CT; 4x2-203/50, 8x1-75/50, 8x1-37/50, 2x3-550TT, 1seaplane (CAMS.37)	
		9	Tourville	1928			
Mulhouse	1	1	Mulhouse	1912		5587t, 138.7x13.5x4.5m, 16b,2t, 25000hp, 27kts, 354p; 60belt, 40deck, 50shields, 100CT; 7x1-150/45, 2x1-88/45, 2x1-500TT, 120m	
Strasbourg	1	2	Strasbourg	1915		6382t, 142.7x13.8x5.8m, 12b,2t, 29000hp, 28kts, 385p; 60belt, 40deck, 50shields, 100CT; 7x1-150/45, 2x1-88/45, 4x1-500TT, 120m	
CL Metz	1	3	Metz	1916		7125t, 151.4x14.2x6.0m, 12b,2t, 45900hp, 27.8kts, 475p; 60belt, 40deck, 50shields, 100CT; 8x1-150/45, 2x1-88/45, (2+2x1)-500TT, 200m	

						
Thionville	1	4	Thionville	1915		4010t, 130.6x12.8x5.3m, 16b,2t, 30178hp, 27kts, 340p; 60belt, 20deck, 40shields, 50CT; 9x1-100/50, 1x1-66/50, 1x1-47/44, 3x2-533TT
Duguay Trouin	3	5	Duguay Trouin	1926		9350t, 181.6x17.2x5.2m, 8b,4gt, 100000hp, 33kts, 578p; 20magazines, 20deck, 25turrets, 25CT; 4x2-155/50, 4x1-75/50, 4x3-550TT, 2seaplanes (F.B.A.17)
		6	Lamotte-Picquet	1926		
		7	Primaguet	1926		

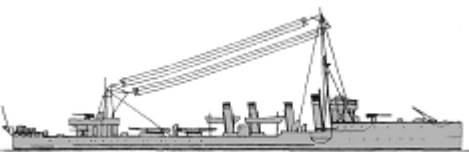
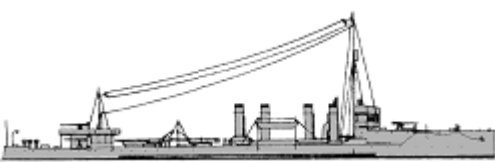
## TORPEDO SHIPS

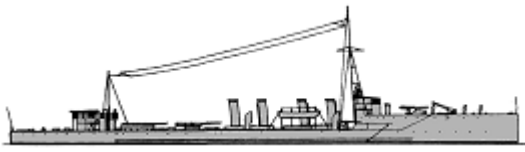
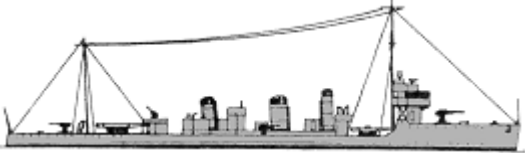
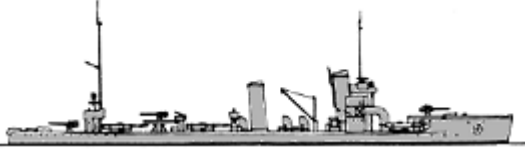
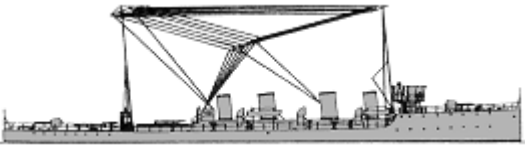

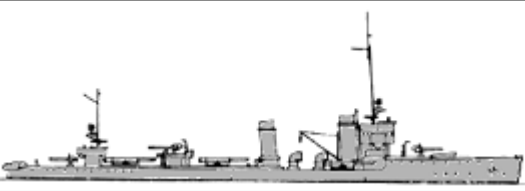
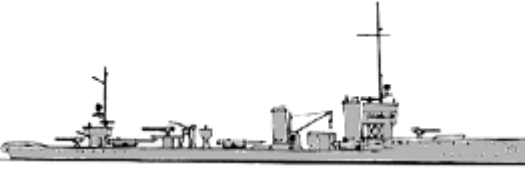

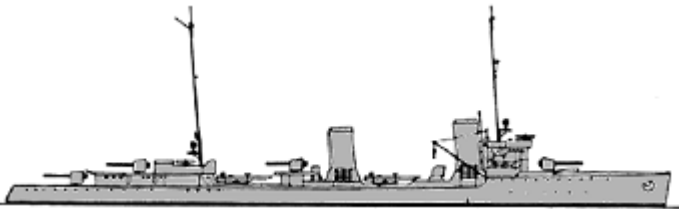
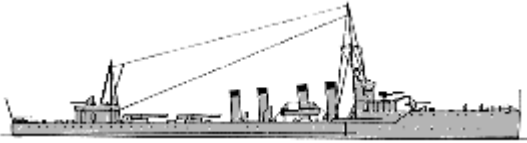
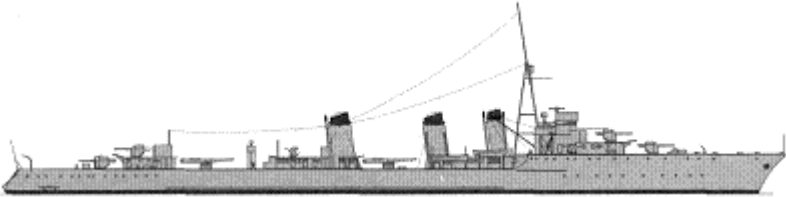
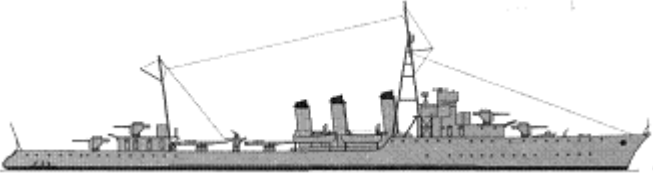
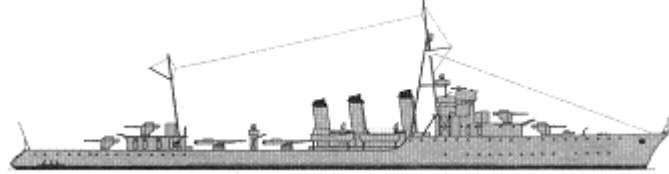
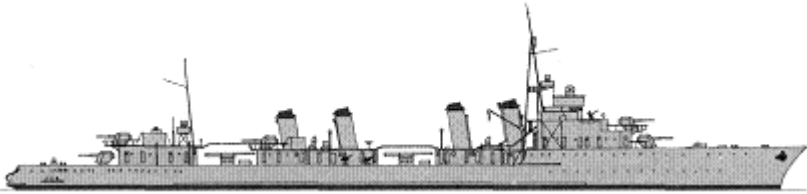

Claymore	2	1	Carquois	1908		356t, 58.0x6.5x3.0m, 2b,2vte, 6800hp, 28kts, 60p; 1x1-65/50, 6x1-47/50, 2x1-450TT
		2	Trident	1909		
Branlebas	1	3	Glaive	1910		344t, 57.9x6.7x2.4m, 2b,2vte, 6800hp, 27.5kts, 60p; 20belt; 1x1-65/50, 6x1-47/50, 2x1-450TT
Spahi	1	4	Aspirant Herber	1912		550t, 64.0x6.6x2.3m, 4b,2vte, 7500hp, 28kts, 79p; 6x1-65/50, (1+2x1)-450TT
Bouclier	3	5	Bouclier	1911		820t, (72.3-78.3)x(7.6-8.0)x(2.8-3.3)m, 4b,3t(5)-2t(6,7), 13000hp, 30kts, 83p; 2x1-100/45, 1x1-75/35, 4x1-65/50, 2x2-450TT, 2DCR
		6	Commandant Rivière	1913		
		7	Dehorter	1913		
Bisson	4	8	Bisson	1913		855t, 78.1x8.6x3.1m, 4b,2t, 15000hp, 30kts, 83p; 2x1-100/45, 1x1-75/35, 4x1-65/50, 2x2-450TT, 2DCR
		9	Commandant Lucas	1914		
		10	Protet	1914		
		11	Mangini	1914		

DD	Enseigne Roux	2	12	Enseigne Roux	1916		1075t, 82.6x8.6x3.0m, 4b,2t, 17000hp, 30kts, 81p; 2x1-100/45, 1x1-75/35, 4x1-65/50, 2x2-450TT, 2DCR
		13	Mécanicien Principal Lestin	1916			
	Arabe	12	14	Algérien	1917		750t, 83.0x7.3x2.4m, 4b,2vte, 10000hp, 29kts, 86p; 1x1-120/40, 4x1-76/40, 2x2-450TT
			15	Annamite	1917		
			16	Arabe	1917		
			17	Bambara	1917		
			18	Hova	1917		
			19	Kabyle	1917		
			20	Marocain	1917		
			21	Sakalave	1917		
	22	Sénégalais	1917				
	23	Somali	1917				
24	Tonkinois	1917					
25	Touareg	1917					
Pierre Durand	1	26	Pierre Durand	1916		1188t, 82.0x8.3x3.4m, 3b,2t, 23500hp, 34kts, 85p; 3x1-105/45, (2x2+2x1)-500TT, 24m	
Matelot Leblanc	1	27	Matelot Leblanc	1917		1045t, 85.4x7.8x2.4m, 6b,2t, 22360hp, 32.6kts, 114p; 2x1-100/50, 6x1-66/50, 2x2-450TT	
Buino	1	28	Buino	1918		1188t, 82.0x8.3x3.5m, 3b,2t, 23500hp, 34kts, 105p; 3x1-105/45, (2x2+2x1)-500TT, 24m	
Chastang	4	29	Chastang	1918		1170t, 83.1x8.3x3.6m, 3b,2t, 24000hp, 32kts, 105p; 3x1-105/45, (2x2+2x1)-500TT, 24m	
		30	Vesco	1918			
		31	Mazaré	1918			
		32	Deligny	1918			
Rageot de la Touche	2	33	Rageot de la Touche	1918		1147t, 84.5x8.4x3.4m, 3b,2t/1t(2), 24500hp, 32kts, 105p; 3x1-105/45, (2x2+2x1)-500TT, 24m	
		34	Marcel Delage	1920			
Amiral Sénès	1	35	Amiral Sénès	1919		2415t, 106.0x10.2x3.4m, 4b,2t, 45000hp, 36kts, 188p; 4x1-150/45, 2x2-600TT, 40m	





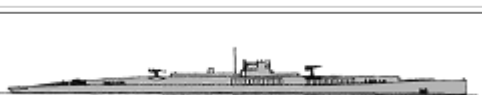
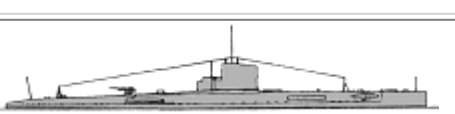
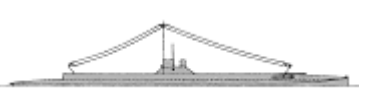
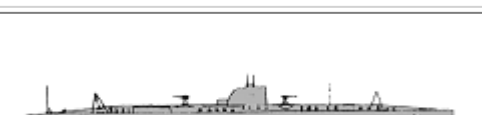

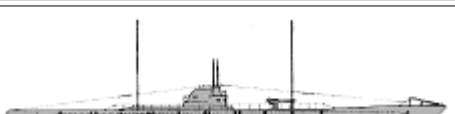
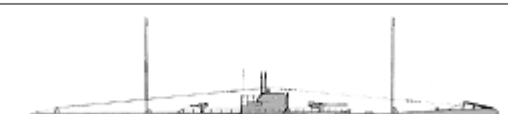
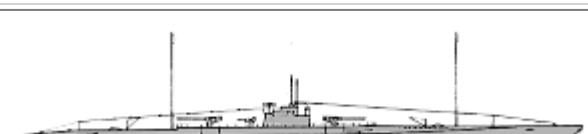

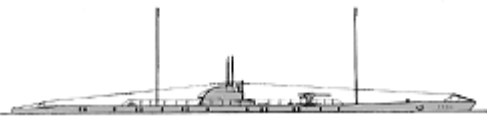

						
Enseigne Gabolde	1	36	Enseigne Gabolde	1923		950t, 83.6x8.2x3.1m, 4b,2gt, 20000hp, 31kts, 80p; 3x1-100/45, 1x1-75/35, 2x2-500TT, 2DCR
Chacal	6	37	Tigre	1925		3050t, 126.8x11.3x4.1m, 5b,2gt, 50000hp, 35.5kts, 195p; 5x1-130/40, 2x1-75/50, 2x3-550TT, 4DCT, 2DCR
		38	Jaguar	1926		
		39	Chacal	1926		
		40	Panthère	1926		
		41	Lynx	1927		
		42	Léopard	1927		
Bourrasque	12	43	Simoun	1926		1900t, 105.8x9.6x4.3m, 3b,2gt, 33000hp, 33kts, 142p; 4x1-130/40, 1x1-75/50, 2x3-550TT, 2DCT, 2DCR
		44	Orage	1926		
		45	Tempête	1926		
		46	Bourrasque	1926		
		47	Tramontane	1927		
		48	Ouragan	1927		
		49	Mistral	1927		
		50	Siroco	1927		
		51	Trombe	1927		
		52	Typhon	1928		
		53	Cyclone	1928		
		54	Tornade	1928		
L'Adroit	8	55	La Palme	1928		2000t, 107.2x9.8x4.3m, 3b,2gt, 34000hp, 33kts, 142p; 4x1-130/40, 1x1-75/50, 2x3-550TT, 2DCT, 2DCR
		56	Le Mars	1928		
		57	La Railleuse	1928		
		58	Le Fortune	1928		
		59	Brestois	1928		
		60	Boulonnais	1928		
		61	L'Alcyon	1929		
		62	L'Adroit	1929		
Guépard	1	63	Guépard	1929		3200t, 130.2x11.8x4.7m, 4b,2gt, 64000hp, 35.5kts, 230p; 5x1-139/40, 4x1-37/50, 2x2-13.2, 2x3-550TT, 4DCT, 2DCR
		1	No337	1908		

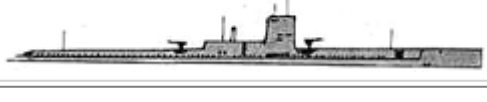
TB	No295	3					101t, 38.0x4.4x1.9m, 2b,1vte, 2000hp, 26kts, 23p; 1x1-75/35, 2x5-37/20, 1-450TT
			2	No349	1906		
			3	No369	1908		

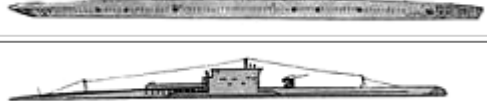
## SUBMARINES





	Brumaire	1	1	Brumaire	1913		397/551t, 52.1x5.1x3.1m, 2d/em, 840/660hp, 13/8.8kts, 29p; 1x1-47/50, 7-450TT
	Gustave Zédé	2	2	Gustave Zédé	1914		849(2)-820(3)/1098(2)-1047(3)t, 74.0x6.0x3.7m, 2d/em, 2400/1640hp, 15(2)-17.3(3)/11.4(2)-10.5(3)kts, 47p; 1x1-75/35, 1x1-47/50, 8-450TT(2), (8+1x2)-450TT(3)
			3	Néréide	1916		
	Amphitrite	3	4	Amphitrite II	1915		414/609t, 53.9x5.4x3.3m, 2d/em, 800/700hp, (12-13)/9.5kts, 29p; 1x1-75/35, 8-450TT
			5	Atalante II	1915		
			6	Andromaque	1916		
	Bellone	3	7	Bellone	1916		523/788t, 60.6x5.4x3.5m, 2d/em, 1640/800hp, 14.7/9.5kts, 38p; 1x1-75/35, 8-450TT
			8	Gorgone	1916		
			9	Hermione	1917		
	Dupuy de Lôme	2	10	Dupuy de Lôme	1916		833/1287t, 75.0x6.4x3.6m, 2d/em, 2400/1640hp, 15/11kts, 43p; 1x1-75/35, 1x1-47/50, 8-450TT
			11	Sané	1916		
	Diane	1	12	Daphné	1916		633/891t, 68.0x5.5x3.7m, 2d/em, 1800/1400hp, 17/11.5kts, 43p; 1x1-75/35, 10-450TT
	Armide	3	13	Armide	1916		457/670t, 56.2x5.2x3.0m, 2d/em, 2200/900hp, 17.5/11kts, 31p; 1x1-75/35(14), 1x1-47/50(13,15), 6-450TT(13), 4-450TT(14,15)
			14	Amazone II	1917		
			15	Antigone	1917		
	Lagrange	4	16	Lagrange	1918		920/1318t, 75.2x6.3x3.6m, 2d/em, 2600/1640hp, 16.5/11kts, 47p; 2x1-75/35, 8-450TT
			17	Romazotti	1918		
			18	Laplace	1921		
			19	Regnault	1924		
	Victor Réveille	1	20	Victor Réveille	1916		755/832t, 56.8x5.9x4.9m, 2d/em, 900/800hp, 9.9/7.8kts, 32p, 50m; 1x1-105/45, 2-500TT, 38m
	Jean Autric	2	21	Jean Autric	1917		798/1000t, 71.6x6.3x3.9m, 2d/em, 2400/1200hp, 16.4/8.4kts, 36p, 50m; 1x1-105/45, 1x1-88/30, 6-500TT
			22	Léon Mignot	1917		
	René Audry	1	23	René Audry	1918		1164/1512t, 81.5x7.4x4.2m, 2d/em, 2400/1200hp, 14.7/7kts, 40p, 75m; 1x1-150/45, 4-500TT, 72m
	Halbronn	1	24	Halbronn	1918		1930/2483t, 92.0x9.1x5.3m, 2d+1dg/2em(2), (3500+450)/1780hp, 15.8/7.6kts, 62p, 75m; 60CT; 2x1-150/45, 6-500TT
SS	Pierre Marrast	2	25	Pierre Marrast	1918		821/1002t, 71.6x6.3x3.9m, 2d/em, 2400/1230hp, 16.2/8.2kts, 39p, 50m; 1x1-105/45, 6-500TT



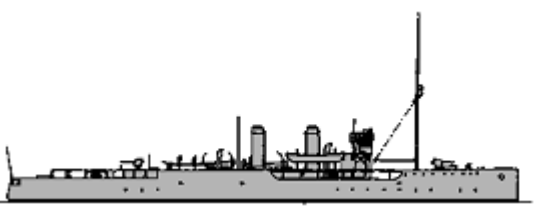
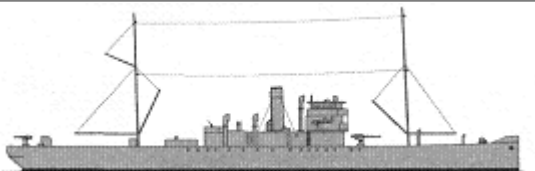

		26	Jean Roulier	1919		
Trinité-Schillemans	2	27	Trinité-Schillemans	1918		510/640t, 55.5x5.8x3.7m, 2d/em, 1100/788hp, 13/7.4kts, 34p, 75m; 1x1-105/45, 5-500TT
		28	Carrisan	1918		
Jean Corre	1	29	Jean Corre	1919		539/656t, 55.5x5.8x3.9m, 2d/em, 1060/788hp, 13.5/7.5kts, 34p, 75m; 1x1-105/45, 5-500TT
Fulton	2	30	Fulton	1920		870/1247t, 74.0x6.4x3.6m, 2d/em, 2700/1640hp, 16.5/11kts, 47p; 2x1-75/35, 8-450TT
		31	Joessel	1920		
O'Byrne	2	32	O'Byrne	1921		342/513t, 52.4x4.7x2.7m, 2d/em, 1020/400hp, 14/8kts, 25p; 1x1-47/50, 4-450TT
		33	Henry Fournier	1921		
Maurice Callot	1	34	Maurice Callot	1922		931/1298t, 75.5x6.7x3.5m, 2d/em, 2900/1640hp, 16.5/10.5kts, 48p; 1x1-75/35, 6-450TT, 27m
Pierre Chailley	1	35	Pierre Chailley	1922		884/1191t, 70.0x7.5x4.0m, 2d/em, 1800/1400hp, 13.7/8.5kts, 44p; 1x1-100/45, 4-450TT, 40m
Requin	9	36	Requin	1926		1150/1441t, 78.3x6.8x5.1m, 2d/em, 2900/1800hp, 15/9kts, 51p, 80m; 1x1-100/45, (6+2x2)-550TT
		37	Souffleur	1926		
		38	Narval	1926		
		39	Marsouin	1927		
		40	Dauphin	1927		
		41	Espadon	1927		
		42	Caiman	1927		
		43	Morse	1928		
44	Phoque	1928				
Sirène	4	45	Sirène	1927		609/757t, 64.0x5.2x4.3m, 2d/em, 1300/1000hp, 14/7.5kts, 41p, 80m; 1x1-75/35, (5+1x2)-550TT
		46	Naiïade	1927		
		47	Galathée	1927		
		48	Nymphe	1927		
Ariane	3	49	Ariane	1929		626/787t, 66.0x6.2x4.1m, 2d/em, 1250/1000hp, 14/7.5kts, 41p, 80m; 1x1-100/45, (5+1x2)-550TT
		50	Eurydice	1929		
		51	Danaé	1929		
Circé	3	52	Circé	1929		615/776t, 62.5x6.2x4.0m, 2d/em, 1250/1000hp, 14/7.5kts, 41p, 80m; 1x1-75/35, (5+1x2)-550TT
		53	Calypso	1929		
		54	Thétis	1929		

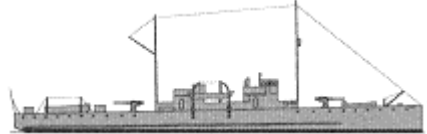
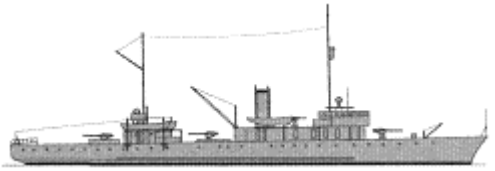

## ESCORTS

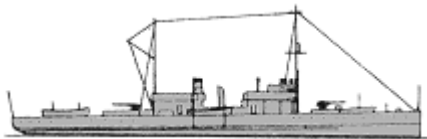
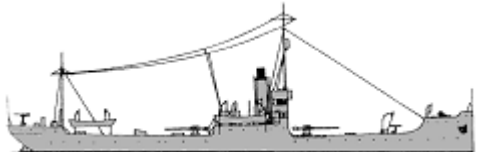
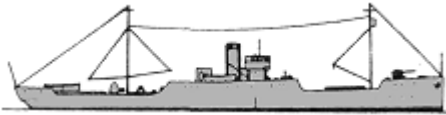
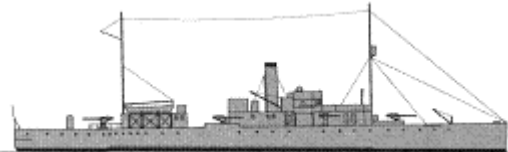
		1	Aldébaran	1916	
		2	Algol	1916	

SL	Aldébaran	7	3	Altair	1916		1470t, 81.5x10.5x4.2m, 2b,1vte, 2800hp, 17.5kts, 103p; 2x1-139/45, 2x1-75/35, 2DCT, 1DCR
			4	Antarès	1916		
			5	Bellatrix	1916		
			6	Cassiopée	1917		
			7	Régulus	1917		
	Andromédé	1	8	Ville d'Ys	1917		1250t, 83.5x12.0x5.0m, 2b,1vte, 2675hp, 17kts, 103p; 1x1-100/45, 3x1-75/35, 2x1-47/40
Ardent		14	1	Agile	1916		400(1,3,6,8,12)-410(2,4,5,7,9-11,13,14)t, 60.2x7.2x2.9m, 2b,1vte(1,3,6,8,12)-2vte(2,4,5,7,9-11,13,14), 1200-2200hp, 14-17kts, 55-60p; 2x1-145/45(3,8,12), 2x1-100/45(1,2,4-7,9-11,13,14), 2DCT, MS
			2	Alerte	1916		
			3	Ardent	1916		
			4	Capricieuse	1916		
			5	Gracieuse	1916		
			6	Inconstant	1916		
			7	Malicieuse	1916		
			8	Sans Souci	1916		
			9	Audacieuse	1917		
			10	Batailleuse	1917		
			11	Dédaigneuse	1917		
			12	Étourdi	1917		
			13	Impétueuse	1917		
			14	Tapageuse	1917		
Friponne		3	15	Diligente	1918		315t, 66.4x7.0x2.8m, 2d, 900hp, 14.5kts, 54p; 2x1-100/45, 2DCT
			16	Engageante	1918		
			17	Surveillante	1918		
Marne		6	18	Marne	1917		601(18)-566(19-23)t, 78.0x8.9x3.4m, 2b,2gt, 5000(18)-4000(19-23)hp, 21(18)-20(19-23)kts, 113p; 4x1-100/45, 1x1-75/35(20), 2x1-65/50(18,19,21-23), 1DCR
			19	Oise	1917		
			20	Somme	1917		
			21	Yser	1917		
			22	Aisne	1918		
			23	Meuse	1918		
Luronne		1	24	Luronne	1917		400t, 60.2x7.2x2.9m, 2d, 630hp, 13.7kts, 54p; 2x1-100/45, 2DCT
Conquérante		2	25	Conquérante	1917		457t, 66.4x7.9x2.8m, 2d, 1800hp, 17kts, 54p; 2x1-100/45, 2DCT
			26	Valliante	1917		

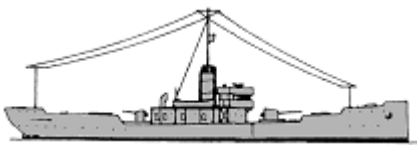

							
FS	Amiens	27	Arras	1918		850t, 74.9x8.7x3.2m, 2b,2gt, 5000hp, 20kts, 103p; 2x1-139/55, 1x1-75/35, 2DCT, 1seaplane (F.B.A.17(31))	
		28	Reims	1918			
		29	Amiens	1920			
		30	Bapaume	1920			
		31	Belfort	1920			
		32	Calais	1920			
		33	Coucy	1920			
		34	Épernay	1920			
		35	Épinal	1920			
		36	Lassigny	1920			
		37	Nancy	1920			
		38	Tahure	1920			
		25	39	Toul			1920
		40	Laffaux	1920			
		41	Vimy	1920			
		42	Craonne	1921			
		43	Liévin	1921			
		44	Lunéville	1921			
		45	Montmiral	1921			
		46	Péronne	1921			
		47	Révigny	1921			
48	Vitry-le-François	1921					
49	Baccarat	1922					
50	Béthune	1922					
51	Montdement	1922					
Ailette	2	52	Ailette	1918		492t, 70.0x8.3x3.1m, 2b,2gt, 4000hp, 20kts, 107p; 4x1-100/45, 2x1-65/50	
		53	Escaut	1918			
Scarpe	3	54	Ancre	1918		604t, 76.2x8.7x3.3m, 2b,2gt, 5000hp, 20kts, 107p; 4x1-100/45, 1x1-65/50, 2DCT	
		55	Scarpe	1918			
		56	Suipe	1918			
Flamant	1	57	Quentin Roosevelt	1918		585t, 50.0x8.4x5.8m, 2b,1vte, 1200hp, 14.5kts, 53p; 1x1-75/35, 1x1-47/50	
		58	Du Chaffault	1918			



Dubordieu	5	59	Dubordieu	1918		453t, 64.9x8.2x3.1m, 2b,2gt, 2000hp, 16.5kts, 74p; 1x1-139/45, 1x1-100/45, 2DCT
		60	Enseigne Henry	1919		
		61	Du Couëdic	1920		
		62	Duperré	1920		
C1	15	1 - 15	C25, 26, 31, 51, 56, 58, 67, 72, 74, 81, 91, 92, 95, 96, 98	1917 - 1918		85t, 33.5x4.7x2.3m, 3pe, 660hp, 16.5kts, 27p; 1x1-75/35, 1DCT
C101	14	16	Ch102	1919		150t, 43.4x5.2x2.4m, 2b,2vte, 1300hp, 16.5kts, 31p; 1x1-75/35, 1DCT
		17	Ch103	1919		
		18	Ch104	1919		
		19	Ch105	1919		
		20	Ch106	1919		
		21	Ch107	1919		
		22	Ch108	1919		
		23	Ch109	1919		
		24	Ch110	1919		
		25	Ch113	1920		
		26	Ch114	1920		
27	Ch115	1920				
28	Ch116	1920				
29	Ch117	1920				
Loup	3	1	Loup	1917	No picture	285t, 1b,1vte, 600hp, 10kts; 1x1-75/35
		2	Marcassin	1917		
		3	Sanglier	1917		
Hippopotame	4	4	Mammoth	1917	No picture	970t, 2b,1vte, 1800hp, 12kts; 2x1-75/35
		5	Hippopotame	1918		
		6	Rhinocéros	1918		
		7	Mastodonte	1919		
Aurochs	4	8	Zébu	1917	No picture	290t, 1b,1vte, 650hp, 10kts; 1x1-90/24, 1x1-47/40
		9	Aurochs	1918		
		10	Renne	1918		
		11	Élan	1919		
Clameur	5	12	Fracas	1917	No picture	370t, 2b,1vte, 720hp, 12kts; 1x1-90/24
		13	Clameur	1918		
		14	Tintamarre	1918		
		15	Tumulte	1918		
		16	Vacarme	1918		
Athlete	2	17	Athlete	1917	No picture	585t, 1b,2vte, 500hp, 12kts; 2x1-120/40
		18	Lutteur	1919		
Navarin	3	19	Lutzen	1918	No picture	640t, 1vte, 500hp, 11kts, 31p; 1x1-100/45
		20	Malakoff	1918		

		21	Sebastopol	1918		
PC	Mauviette	1	22	Passereau II	1918	 460t, 43.5x7.3x4.2m, 1b,1vte, 10kts; 1x1-90/24, 1x1-47/40, MS
Pluvier	9	23	Faisan	1918	No picture	(680-780)t, 1vte, 750hp, 11kts
		24	Gelinotte	1918		
		25	Heron II	1918		
		26	Paon	1918		
		27	Pigeon	1918		
		28	Pingouin II	1918		
		29	Pintade	1918		
		30	Ramier	1918		
		31	Tourterelle	1918		
Crabe	11	32	Cèdre	1918	No picture	(360-370)t, 1b,1vte, 400hp, (9-10)kts; 1x1-90/24
		33	Chêne	1918		
		34	Crabe	1918		
		35	Erable	1918		
		36	Orme	1918		
		37	Tourteau	1918		
		38	Frêne	1919		
		39	Hêtre	1919		
		40	Peuplier	1919		
		41	Calmar	1920		
		42	Homard	1920		
Bouvines	1	43	Fleurus	1919	No picture	684t, 45.0x7.8xm, 1vte, 500hp, 9.5kts; 2x1-100/45



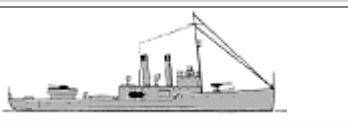

## OTHER FIGHTING SHIPS

PR	Doudart de la Grée	1	1	Doudart de la Grée	1909	 183t, 54.4x6.7x1.0m, 2b,2vte, 900hp, 14kts, 66p; 1x1-75/35, 2x1-37/23
	Balny	1	2	Balny	1920	 226t, 54.4x6.7x1.0m, 2b,2vte, 900hp, 14kts, 59p; 1x1-75/35, 2x1-37/23
	Vigilante	2	3	Vigilante	1923	 218t, 51.8x7.7x1.2m, 2b,2vte, 600hp, 12kts, 42p; 2x1-75/35, 2x1-37/23
			4	Argus	1923	
	Ch101	2	5	Commandant Bourdais	1920	 150t, 43.4x5.2x2.4m, 2b,2vte, 1300hp, 16.5kts, 31p; 1x1-75/35
			6	Avalanche	1920	

## COASTAL FORCES

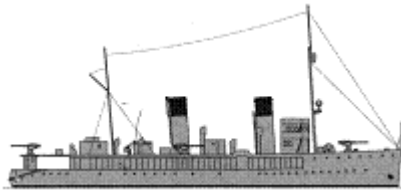
PT	VTB1	7	1 - 7	VTB1 - 7	1928 - 1929		11t, 18.3x3.4x0.9m, 2pe, 900hp, 40kts, 5p; 2-400TT
----	------	---	-------	----------	-------------	---	--

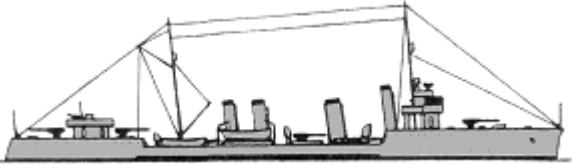
## MINE WARFARE SHIPS

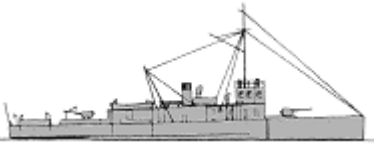
AML	-	1	Castor	1916		4576t, 75.2x17.3x6.4m, 6b,3vte, 6400hp, 14kts; 4x1-100/45, 2x1-37/50, 268m	
		2	Pollux	1917		2463t, 64.2x15.5x6.0m, 6b,3vte, 4000hp, 14kts; 4x1-100/45, 2x1-37/50, 236m	
MS	No295	1	No315	1905		101t, 38.0x4.4x1.9m, 2b,1vte, 2000hp, 26kts, 23p; 2x5-37/20, 1-450TT, MS	
		2	No321	1907			
		3	No327	1907			
	Aventurier	4	4	Opiniâtre	1914		1250t, 88.5x8.8x3.1m, 4b(4,6)-3b(5,7),2t, 12000(4,6)-16000(5,7)hp, 22(4,6)-26(5,7)kts, 140p; 3x1-100/45, 1x1-47/50, MS
			5	Aventurier	1914		
			6	Téméraire	1914		
			7	Intrépide	1914		
	Granit	3	8	Granit	1918		360t, 57.6x7.9x2.3m, 1b,1vte, 600hp, 12.5kts, 63p; 2x1-65/50, MS
			9	Mica	1918		
			10	Porphyre	1918		
	Albâtre	2	11	Meulière	1919		380t, 57.6x7.9x2.3m, 1b,1vte, 500hp, 10.5kts, 63p; 1x1-65/50, MS
12			Quartz	1919			
TL	Campanule	1	1	Perce-Neige	1919	No picture	80t, 1pe, 325hp, 13kts; MS

## NAVAL AVIATION (approximately, maximal number of delivered planes signed)

Deck planes	F: 30 D.1ter, 18 Wib.74; FR: 24 P.L.5, 18 Wib.75; R: 39 P.L.4 (delivery till 1931)
Seaplanes	B: 33 F.B.A.17 HMB.2; R: 141 F.B.A.17 HE.2 (delivery till 1931), 10 F.B.A.17 HL.2, 15 CAMS.37A (delivery till 1935)



[home](#)[World navies yesterday](#)[1930](#)

# GERMANY 01 January 1930

*IN SERVICE: 6 battleships-predreadnoughts, 5 protected cruisers, 3 light cruisers, 29 torpedo boats, 3 fishery protection vessels, 2 dispatch vessels, 10 motor torpedo boats, 5 motor anti-submarine boats, 2 mine transports, 29 minesweepers, 8 minesweeping boats*

## CAPITAL SHIPS

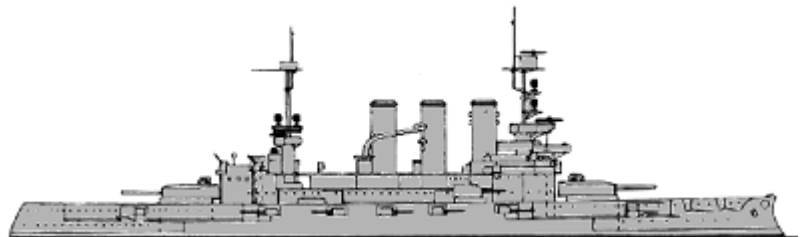
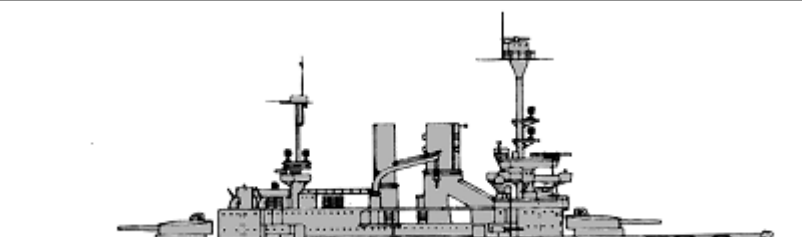

BB	Braunschweig	1	Braunschweig	1904		<p>14394t, 127.7x25.6x8.1m, 14b(1, 2)-10b(3), 2vte, 17700(1, 2)-16500(3)hp, 18.7(1, 2)-18.2(3)kts, 743p; 225belt, 40deck, 250turrets, 300CT; 2x2-283/40, 12x1-173/40(1), 10x1-173/40(2), 14x1-173/40(3), 8x1-88/45, 2-500TT(1), 4-500TT (2, 3)</p>		
		2	Elsass	1904				
		3	Hessen	1905				
	Deutschland	4	Hannover	1907				<p>13994t, 127.6x22.2x8.3m, 12b, 2vte, 20540hp, 18.5-19kts, 743p; 240belt, 40deck, 280turrets, 300CT; 2x2-283/40, 14x1-173/40(4), 14x1-149/45(5, 6), 4x1-88/45(4, 6), 2x1-88/45(5), 4-500TT</p>
		5	Schlesien	1908				
		6	Schleswig-Holstein	1908				

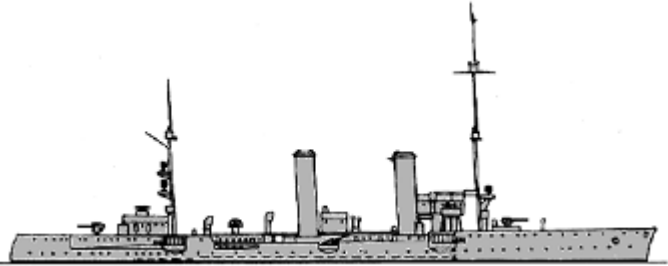
## CRUISERS

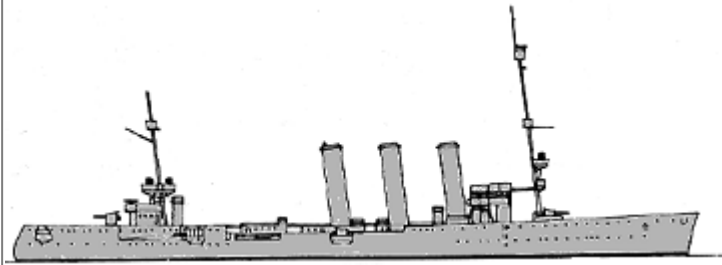
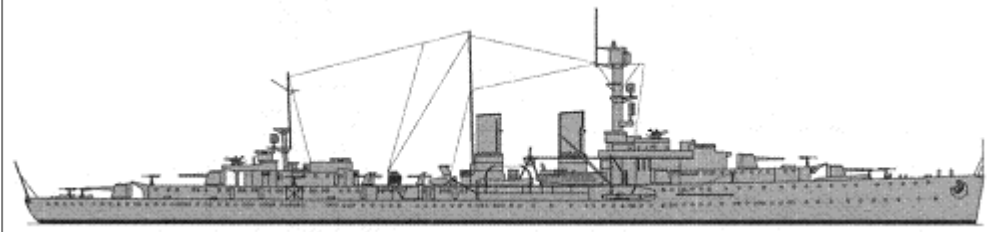
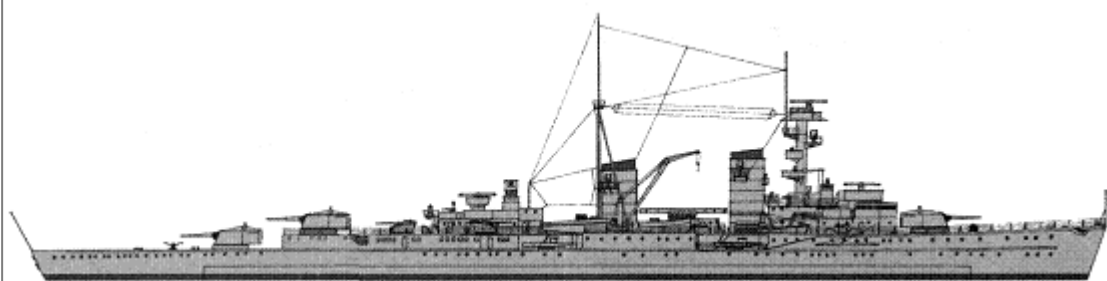
Gazelle	1	Nymphe	1900		<p>3082(1, 2)-3180(3)t, 108.7(1, 2)-105.0(3)x12.2(1, 2)-12.4(3)x5.4(1, 2)-5.5(3)m, 10b(1)-9b(2, 3), 2vte, 9020(1,2)-8580(3)hp, 21.8(1,2)-21.5(3)kts, 249(1,2)-259(3)p; 25deck, 50shields, 80CT; 10x1-105/45(1,2), 10x1-105/40(3), 2x1-500TT, 200m(3)</p>
	2	Amazone	1901		
	3	Arcona	1903		
	4	Hamburg	1904		

CL	Bremen	2	5	Berlin	1905		3816t, 111.1(4)-113.8(5)x13.3x5.6m, 10b, 2vte, 11750hp, 23kts, 288p; 35deck, 50shields, 100CT; 10x1-105/45(4), 8x1-105/45(5), 2x1-500TT
	Emden	1	6	Emden	1925		6990t, 155.1x14.3x6.6m, 10b, 2gt, 45900hp, 29kts, 650p; 50belt, 40deck, 20shields, 100CT; 8x1-149/45, 2x1-88/45, 2x2-500TT, 120m
	Königsberg	2	7	Königsberg	1929		7700t, 174.0x15.2x5.6m, 6b,2gt/2d(2), 65000/1800hp, 32kts, 850p; 65belt, 40deck, 30turrets, 100CT; 3x3-149/60, 2x1-88/45, 4x3-500TT, 120m
		8	Karlsruhe	1929			

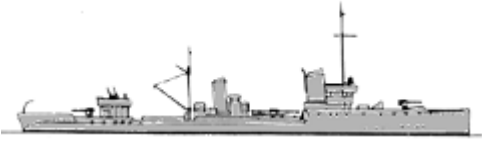
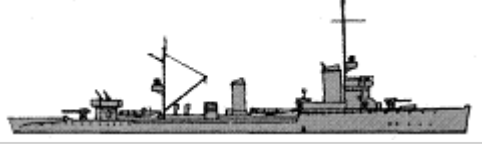
### TORPEDO SHIPS

V150	7	1	T151	1908		691t, 72.5x7.8x3.0m, 4b,2vte, 10900hp, 30kts, 84p; 2x1-88/45(1,3,4-7), 2x1-88/35(2), 1x2-500TT(1,3,4), 3x1-450TT(2,5-7)
		2	T152	1908		
		3	T153	1908		
		4	T155	1908		
		5	T156	1908		
		6	T157	1908		
		7	T158	1908		
V180	2	8	T185	1910		783(8)-775(9)t, 73.9x7.9x3.1m, 4b,2t, 18000hp, 32kts, 84p; 2x1-105/45, 2x2-500TT
		9	T190	1911		
G192	1	10	T196	1911		810t, 74.0x7.9x3.0m, 4b,2t, 18200hp, 32kts, 76p; 2x1-105/45, 2x2-500TT
G7	4	11	G7	1912		775t, 71.5x7.6x3.0m, 3b,2t, 16000hp, 31.5kts, 74p; 2x1-105/45, 2x1-500TT, 18m
		12	G8	1912		
		13	G10	1912		
		14	G11	1912		
		15	S18	1913		

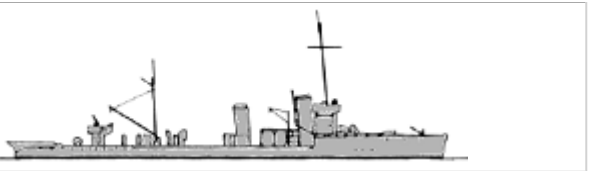
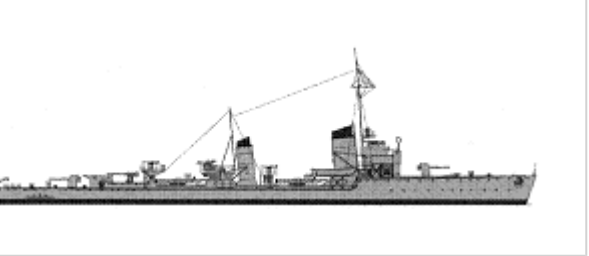
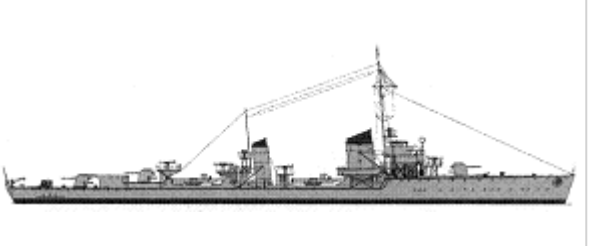
S13	3	16	S19	1913		749t, 71.5x7.4x2.8m, 3b,2t, 15700hp, 32.5kts, 74p; 2x1-105/45(15,17), 2x1-88/45(16), 2x1-500TT, 18m
		17	S23	1913		
		18	Möwe	1926		
Möwe	6	19	Greif	1927		1213(18)-1290(19-23)t, 87.0(18)-88.5(19-23)x8.3x2.8m, 3b,2gt, 22100(18)-23000(19-23)hp, 32(18)-33(19-24)kts, 120p; 3x1-105/45, 2x3-500TT, 30m
		20	Seeadler	1927		
		21	Albatros	1927		
		22	Falke	1927		
		23	Kondor	1928		
Wolf	6	24	Wolf	1928		1320t, 92.6x8.6x2.8m, 3b,2gt, 23000hp, 34kts, 120p; 3x1-105/55, 2x3-500TT, 30m
		25	Iltis	1928		
		26	Jaguar	1929		
		27	Leopard	1929		
		28	Luchs	1929		
		29	Tiger	1929		



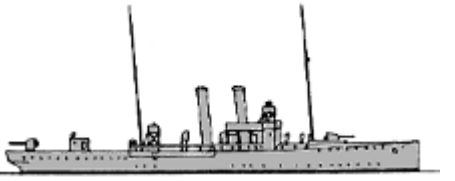
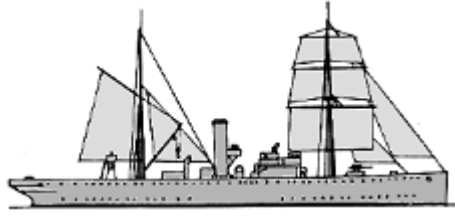
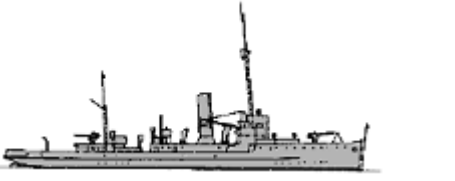



### ESCORTS

FPV	Iltis	1	1	Panther	1902		1193t, 66.9x9.7x3.1m, 4b,2vte, 1300hp, 14kts, 130p, 2x1-105/40(can be fitted)
	Meteor	1	2	Meteor	1924		1504t, 71.1x10.2x3.6m, 2b,2vte, 885hp, 11.5kts, 124p; 1x1-88/45(can be fitted)
	M57	1	3	Zieten	1919		

### OTHER FIGHTING SHIPS

DV	S138	2	1	Pfeil	1907		684t, 70.7x7.8x2.7m, 4b,2vte, 11000hp, 30.3kts, 80p; 2x1-20/65
			2	Blitz	1907		

## COASTAL FORCES

PT	LM14	3	1 - 3	UZ(S)16, 17, 20	1918-1919		7t, 16.5x2.4x0.6m, 3pe, 780(1)-680(2)-740(3)hp, 31.6kts, 7p; 1-450TT
	LM17	1	4	UZ(S)13	1917		8t, 17.0x2.4x0.6m, 3pe, 780hp, 30.8kts, 7p; 1x1-20/60, 1-450TT
	LM21	3	5 - 7	UZ(S)14, 15, 21	1917-1919		7t, 16.0x2.4x0.7m, 3pe, 780hp, 31.8kts, 7p; 1x1-20/60(7), 1-450TT
	Luer	1	8	Luer	1928		23t, 21.0x3.6x1.3m, 3pe, 1350hp, 33.5kts, 8p; 2-450TT (can be fitted)
	Narwal	1	9	Narwal	1928		31t, 21.3x4.1x0.9m, 3pe, 1125hp, 34.8kts, 8p; 2-450TT
	K	1	10	K	1929		16t, 17.4x3.5x1.2m, 2pe, 1060hp, 40kts, 8p; 2-450TT
PS	UZ23	5	1 - 5	UZ27 - 29, 34, 35	1918		60t, 31.0x4.4x1.3m, 2pe, 570hp, 16kts, 14p; 1x1-52/55(4), DCR

## MINE WARFARE

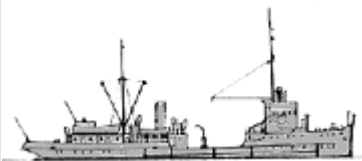
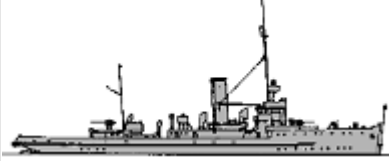
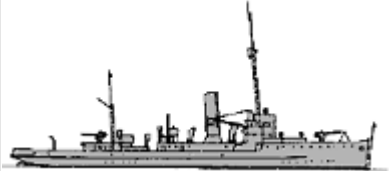
MT	MW I	2	1	Heppens	1917		673t, 53.1x9.3x2.3m, 2b,2vte, 371hp, 9.5kts, 53p; mines
			2	Mariensiel	1917		
MS	M57	28	1	M50	1916		503t, 58.2x7.3x2.2m, 2b,2vte, 1890hp, 16.5kts, 40p; 3x1-88/45, 30m, MS
			2	M60	1918		535-590t, 58.2-59.5x7.3-7.4x2.2-2.3m, 2b,2vte, 1600-1870hp, 15-16.5kts, 40p; 2x1-105/45(2-4,10-29), 2x1-88/45(5,8,9), 3x1-88/45(6,7)
			3	M61	1918		
			4	M66	1917		
			5	M72	1918		
			6	M75	1917		
			7	M84	1917		
			8	M85	1918		
			9	M89	1918		
			10	M98	1918		
			11	M102	1918		
			12	M104	1918		
			13	M107	1918		
			14	M108	1918		
			15	M109	1918		
			16	M110	1918		
			17	M111	1918		
			18	M113	1920		
			19	M115	1918		



		20	M117	1919	
		21	M122	1919	
		22	M126	1919	
		23	M129	1919	
		24	Fuchs (TS)	1919	
		25	M132	1919	
		26	M136	1919	
		27	M145	1919	
		28	M146	1919	
		29	M157	1919	
MSB	F1	1 - 8	F7, 11, 17, 20, 46, 62, 69, 71	1915-1919	 20(1,2)-21(3-8)t, 16.5(1,2)-17.5(3-8)x4.0x1.1m, 2pe, 120-130hp, 10-11kts, 7p; MS

[home](#)

[World navies yesterday](#)



[1930](#)

## Greece 01 January 1930

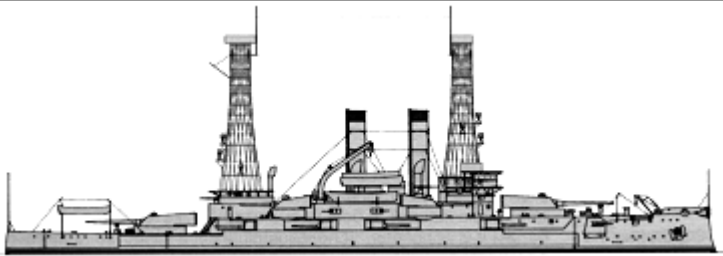
### CAPITAL SHIPS



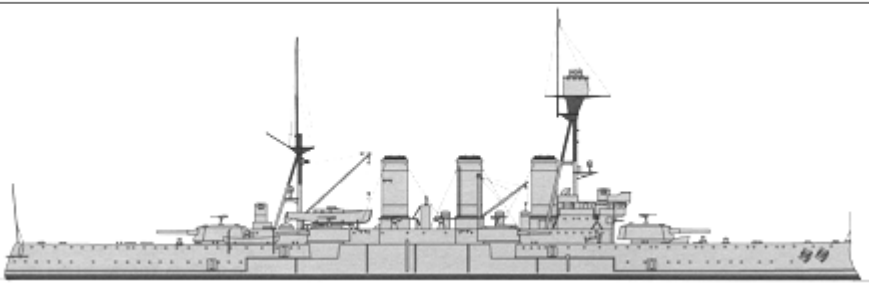



		1	Kilkis	1908		14465t, 116.4x23.5x7.5m, 8b,2vte, 10000hp, 17kts, 744p; 229belt, 37deck, 305turrets, 229CT; 2x2-305/45, 4x2-203/45, 8x1-178/45, 13x1-76/50, 4x1-57/40, 2-533TT
BB	Kilkis	2	Limnos	1908		

### CRUISERS

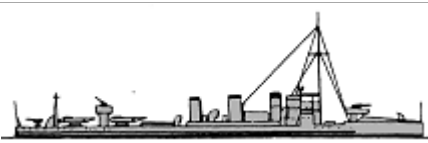
CA	Averof	1	Averof	1911		10200t, 140.8x21.0x7.5m, 22b,2vte, 19000hp, 22.5kts, 670p; 200belt, 50deck, 140turrets, 180CT; 2x2-234/45, 4x2-190/45, 12x1-76/40, 4x1-40/39
	Navarchos Miaoulis	1	Navarchos Miaoulis (TS)	1879	No picture	1820t, 75.0ppx11.0x4.4m, 1vte, 2400hp, 13.5kts, 180p; 3x1-170/25, 1x1-170/20, 6x1-37/23, 3-356TT
CL	Elli	1	Elli	1913		2750t, 98.1x11.9x4.3m, 3b,3t, 7500hp, 20.5kts, 232p; 51slopes, 51deck, 50CT; 3x1-152/50, 2x1-76/40, 2x1-57/40, 2x1-450TT, 110m

### TORPEDO SHIPS

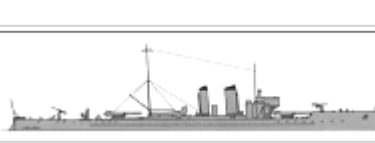
		1	Niki	1906		
--	--	---	------	------	--	--

DD	Niki	2	2	Aspis	1906		350t, 67.0x6.6x2.7m, 4b,2vte, 6800hp, 30kts, 58p; 2x1-88/30, 1x1-40/39, 2x1-450TT
	Thyella	2	3	Thyella	1907		380t, 67.1x6.2x1.8m, 4b,2vte, 6000hp, 30kts, 70p; 2x1-88/30, 1x1-40/39, 2x1-450TT
			4	Sfendoni	1907		
	Aetos	4	5	Aetos	1912		1300t, 89.3x8.5x2.6m, 4b,2t, 19750hp, 32kts, 110p; 4x1-102/50, 2x3-533TT
6			Ierax	1912			
7			Leon	1912			
8			Panthur	1912			
TB	Aigli	4	1	Aigli	1912		125t, 45.0x5.0x1.2m, 2b,1vte, 2400hp, 24kts, 20p; 2x1-57/45, 2x1-450TT
			2	Alkyoni	1914		
			3	Arethousa	1913		
			4	Doris	1913		
	Panormos	2	5	Proussa	1916		330t, 58.8x5.8x1.5m, 2b,2t, 5000hp, 28kts, 38p; 2x1-66/30, 2x2-450TT, 12m
			6	Pergamos	1916		
	Kyzikos	3	7	Kyzikos	1915		330t, 60.5x5.6x1.6m, 2b,2t, 5000hp, 28.5kts, 38p; 2x1-66/30, 2x2-450TT, 12m
			8	Kios	1915		
			9	Kidoniai	1916		

## SUBMARINES

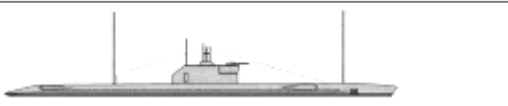
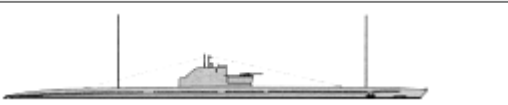
SS	Katsonis	2	1	Katsonis	1928		576/775t, 62.5x5.3x3.4m, 2d/em, 1200/1000hp, 14/9.5kts, 39p, 80m; 1x1-100/40, 6-533TT
			2	Papanikolis	1927		
	Glafkos	1	3	Protefs	1929		790/960t, 68.6ppx5.7x4.2m, 2d/em, 1420/1200hp, 14/9.5kts, 41p, 85m; 1x1-100/40, 1x1-40/39, 8-533TT



## OTHER FIGHTING SHIPS

PG	Hydra	1	1	Amvrakia	1881	No picture	470t, 39.0ppx7.9x2.2m, 2vc, 690hp, 12kts, 64p; 1x1-260/30, 1-356TT
	Kichli	2	2, 3	Kichli, Kissa	1884	No picture	86t, 24.2x4.9x2.1m, 1vc, 162hp, 10kts

## COASTAL FORCES

PT	2	2	1, 2	T1, 2	1929		15t, 16.8x3.4x1.0m, 2pe, 750hp, 40.4kts, 5p; 2-450TR, 1DCR
YP	A1	6	1-6	A1-6	1926-1927	No picture	58t, 13.0xxm; 1x1-76/40, 1DCR

## MINE WARFARE SHIPS





ML	Pleias	1	1	Pleias	1928		520t, 49.4x8.2x3.8m, 1vte, 1000hp, 14kts; 50m
AML	-	3	1	Korgialenios	1916		380t; 50m
			2	Tenedos	1906		450t; 40m
			3	Paralos	1925		395t; 52m

© Ivan Gogin, 2011-14



[home](#)[World navies yesterday](#)[1930](#)

# Hungary 01 January 1930

## RIVER BOATS

PGR	Compo	1	Szeged	1916		133t, 44.0x6.0x1.0m, 2b,2gt, 1200hp, 15kts, 40p; 8belt, 6deck, 10turrets, 10CT; 2x1-77/30(1-3), 2x1-75/60(4), 1x1-50/12(4)	
		2	Kecskemét	1916			
		3	Baja	1916			
		4	Győr	1916			
	Komarom	2	5	Debreczen	1918		160t, 45.5x6.0x1.0m, 2b,2gt, 1400hp, 16kts, 42p; 10belt, 6deck, 22turrets, 10CT; 2x1-84/33(5), 2x1-77/30(6)
		6	Sopron	1918			
YPAR	Hüszar	3	1-3	Honved, Hüszar, Tüzér	1916		18(1)-15(2,3)t, 15.2(1)-16.0(2,3)x3.1(1)-2.8(2,3)x0.7(1)-0.6(2,3)m, 2pe, 100hp, 11.5kts, 9p; 7belt, 5deck, 7turret, 7CT
	Siofok	1	4	Gödöllő	1916		60t, 36.0x4.6x0.9m, 2b,2vte, 800hp, 12kts, 27p; 5belt, 4deck, 5turret, 5CT; 1x1-66/30

## MINE WARFARE SHIPS

MLR	Körös	1	1	Körös	1918		193t, 43.0x6.0x1.4m, 1b,2vte, 600hp, 14kts, 35p; 20m
MLBR	Maros	1	1	Maros	1928		90t, 30.0x5.0x0.8m, 1d, 280hp, 11kts, 9p; 12m or MS

[home](#)

[World navies yesterday](#)

[1930](#)

## Iceland 01 January 1930

### ESCORTS



APC	-	1	1	Sudin	1895		811brt
-----	---	---	---	-------	------	--	--------

© Ivan Gogin, 2011-15

[home](#)[World navies yesterday](#)[1930](#)

# INDIA 01 January 1930

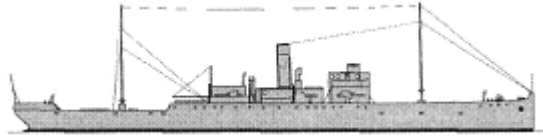
## ESCORTS

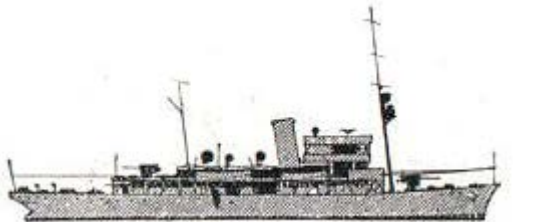
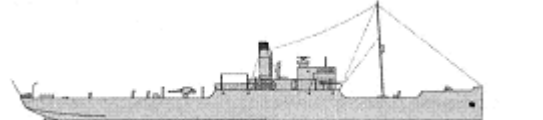
SL	Aubretia	1	1	Cornwallis	1917		1450t, 81.7x10.2x3.4m, 2b, 1vte, 2500hp, 17.5kts, 92p; 2x1-102/40, 1x1-47/50, 2DCT, 1DCR
	Lawrence	1	2	Lawrence	1919		1412t, 69.6x10.4x3.6m, 2b, 2t, 1900hp, 15kts, 119p; 2x1-102/40
	Clive	1	3	Clive	1920		2021t, 80.0x11.7x4.3m, 2b, 2t, 2000hp, 14.5kts, 123p; 2x1-102/40
FS	PC-boat	2	2	Baluchi Pathan	1917 1918		780t, 75.3x7.8(1)-8.2(2)x2.4m, 2b, 2t, 3500hp, 20kts, 55p; 1x1-102/40, 2x1-76/40, 2x1-356TT, 2DCR

[home](#)

[World navies yesterday](#)

[1930](#)

## Ireland 01 January 1930

### ESCORTS

APC	-	1	1	Muirchú	1908		323brt; 1x1-76/40
-----	---	---	---	---------	------	--	-------------------

© Ivan Gogin, 2011-15



[home](#)

[World navies yesterday](#)

[1930](#)

# ITALY 01 January 1930

## CAPITAL SHIPS

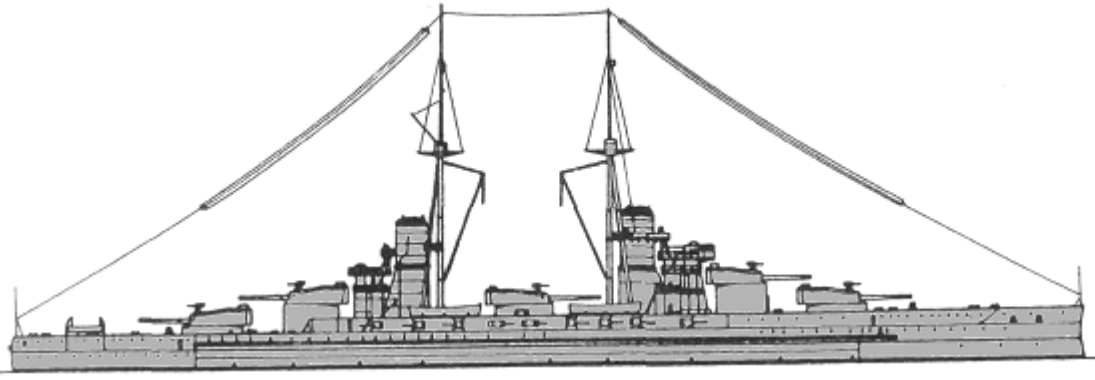
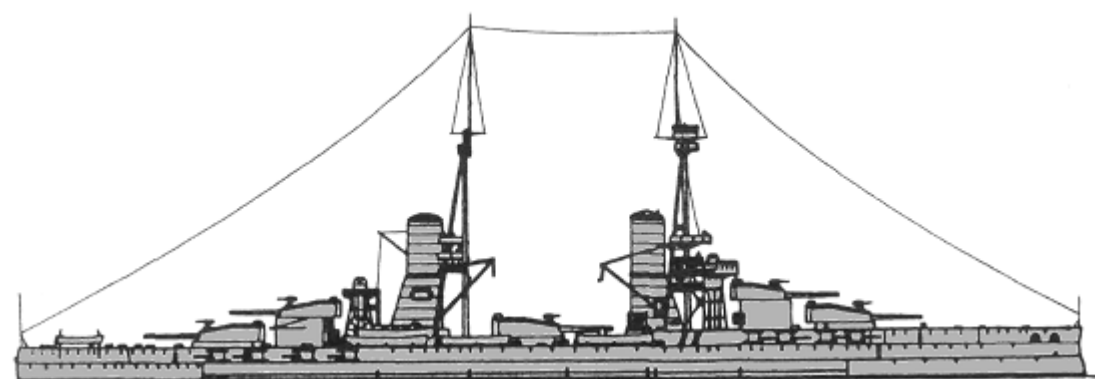
BB	Giulio Cesare	1	Giulio Cesare	1914		24801(1)-24250(2)t, 176.1x28.0x8.7m, 24b(1)-20b(2),4gt, 30700(1)-31278(2)hp, 21.6(1)-22.2(2)kts, 1235p; 250belt, 30+30+24/40deck, 280turrets, 280CT; (3x3+2x2)-305/46, 18x1-120/50, 19x1-76/50(1), 20x1-76/50(2), 2x1-40/39, 1seaplane (P.6), 3-450TT
		2	Conte di Cavour	1915		
BB	Duilio	3	Caio Duilio	1915		24715(3)-24279(4)t, 176.1x28.0x8.9m, 20b,4gt, 30000hp, 21kts, 1232p; 250belt, 44+30+24/40deck, 280turrets, 280CT; (3x3+2x2)-305/46, 16x1-152/45, 25x1-76/50, 2x1-40/39, 1seaplane (P.6), 3-450TT
		4	Andrea Doria	1916		

## AIRCRAFT CARRYING SHIPS

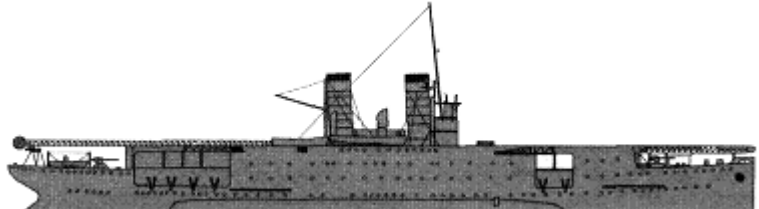
AV	Giuseppe Miraglia	1	Giuseppe Miraglia	1927		5913t, 121.2x15.0x5.2m, 8b,2gt, 12000hp, 21kts, 196p; 4x1-102/35, 20seaplanes (M.18, P.6)
----	-------------------	---	-------------------	------	--	---

## CRUISERS

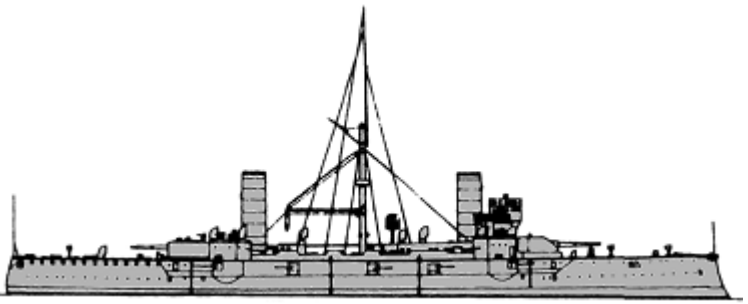
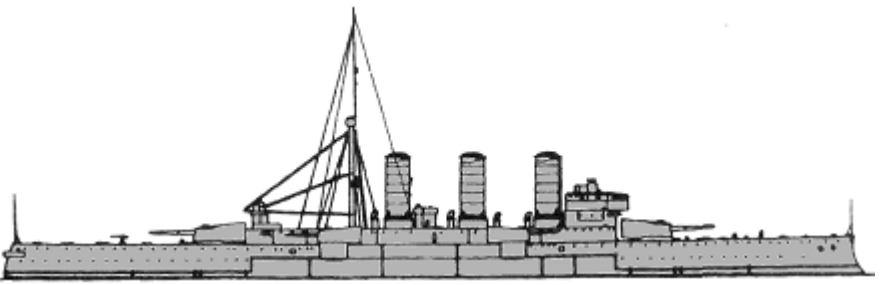
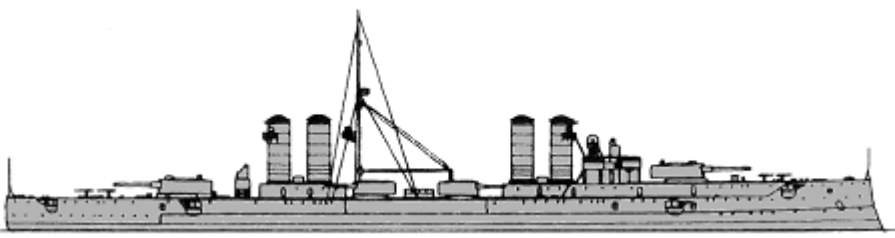
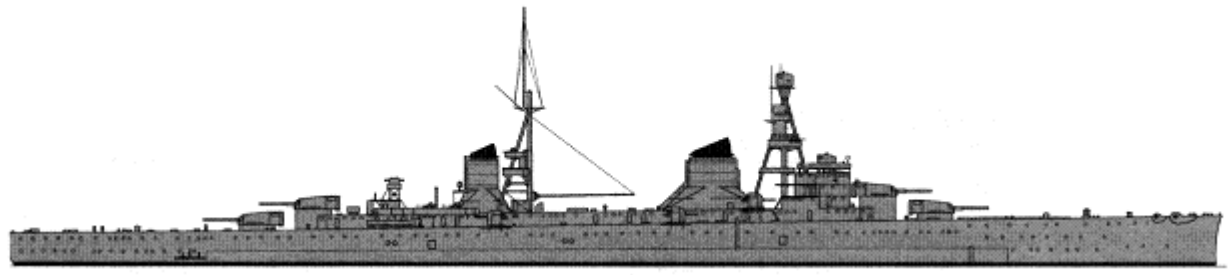
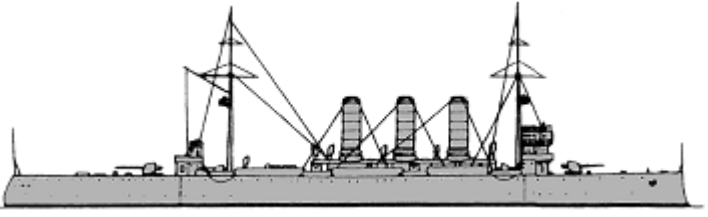

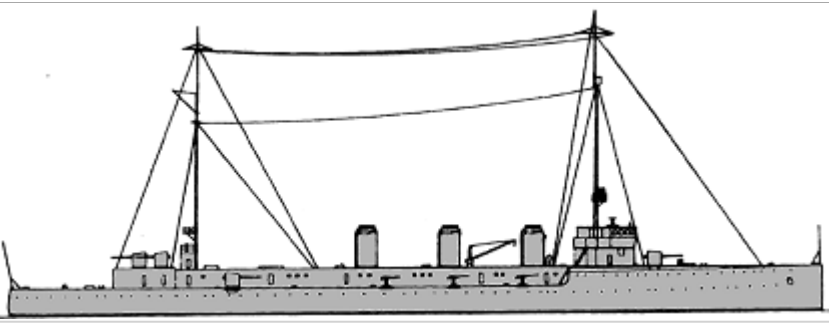
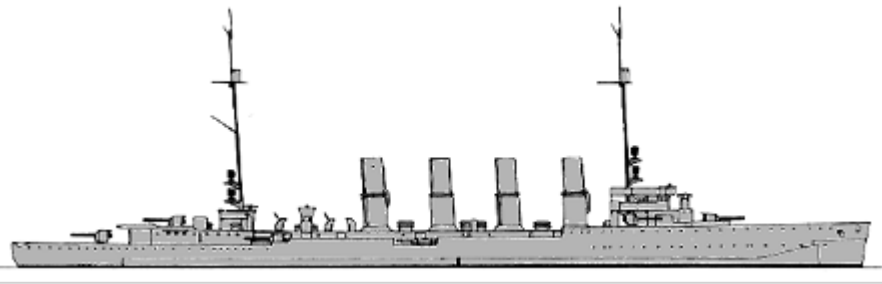
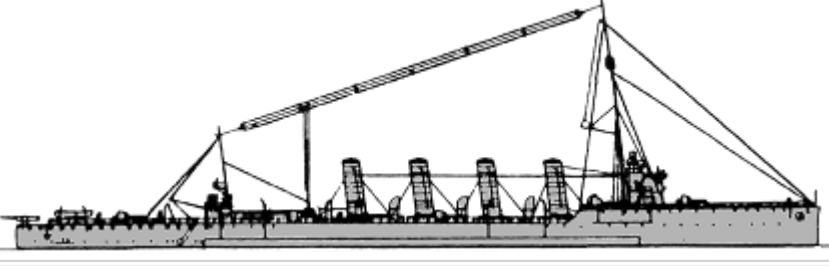
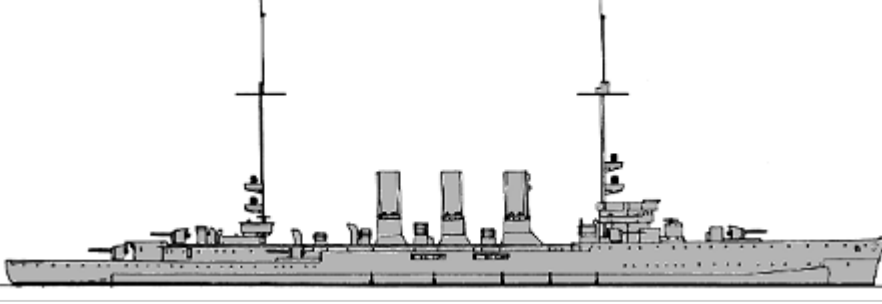
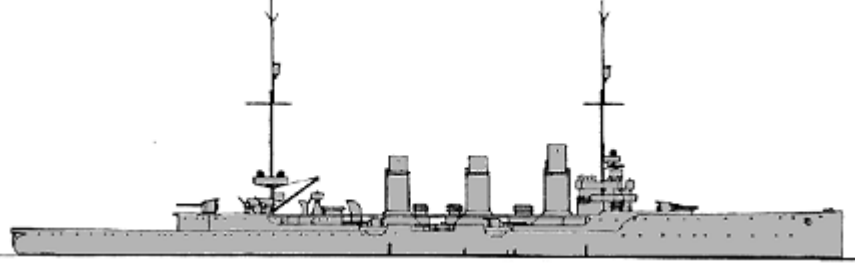

CA	Garibaldi	1	1	Francesco Ferruccio (TS)	1905		7972t, 111.8x18.3x7.1m, 24b,2vte, 13500hp, 19.3kts, 559p; 150belt, 38deck, 150turrets, 150CT; 1x1-254/40, 1x2-203/45, 14x1-152/40, 10x1-76/40, 4-450TT
	Pisa	1	2	Pisa	1909		10600t, 140.5x21.0x7.1m, 22b,2vte, 20000hp, 23kts, 687p; 200belt, 50/130deck, 160turrets, 180CT; 2x2-254/45, 4x2-190/45, 20x1-76/40, 3-450TT, 1seaplane (P.6)
	San Giorgio	2	3	San Giorgio	1910		11300(3)-11900(4)t, 140.8x21.0x7.3(3)-7.8(4)m, 14b, 2vte(3)-4t(4), 19500(3)-23000(4)hp, 23.2(3)-23.8(4)kts, 705p; 200belt, 50deck, 200turrets, 250CT; 2x2-254/45, 4x2-190/45, 16x1-76/40, 3-450TT
			4	San Marco	1911		
	Trento	2	5	Trento	1929		13334(5)-13326(6)t, 197.0x20.6x6.8m, 12b,4gt, 150000hp, 36kts, 781p; 70belt, 50deck, 80turrets, 100CT; 4x2-203/50, 8x2-100/47, 4x1-40/39, 4x1-12.7, 8-533TT, 3seaplanes (P.6)
			6	Trieste	1928		
Libia	1	1	Libia	1913		4466t, 111.8x14.5x5.5m, 16b,2vte, 11530hp, 22.9kts, 314p; 100deck, 76shields, 100CT; 8x1-120/45, 3x1-76/40, 2-450TT	
Quarto	1	2	Quarto	1913		3442t, 131.6x12.8x4.1m, 10b,4t, 25000hp, 28kts, 247p; 40deck, 100CT; 6x1-120/50, 6x1-76/50, 2-450TT, 200m, 1seplane (M.18)	

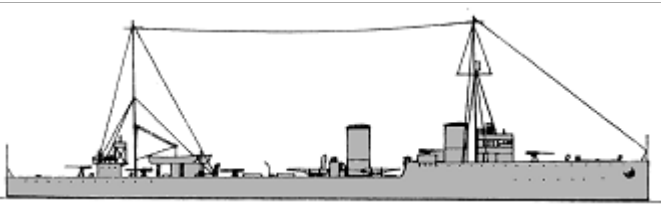
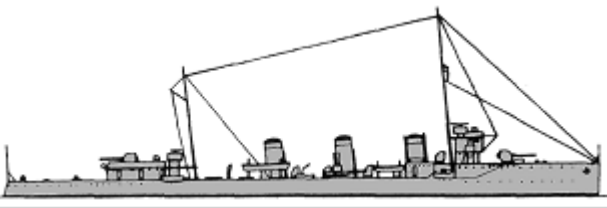
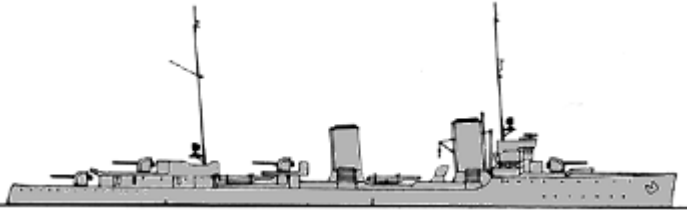
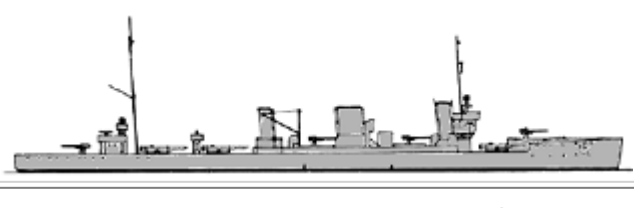
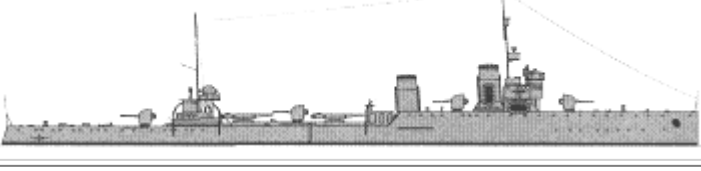
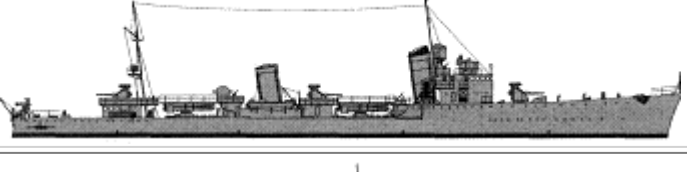
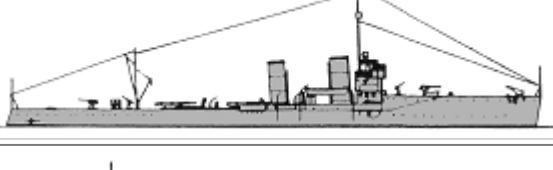
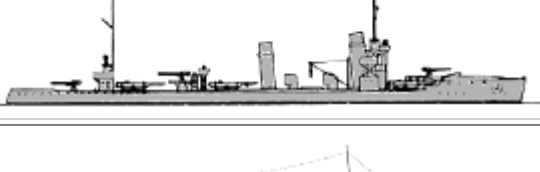
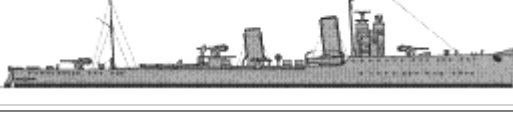

CL						
	Taranto	1 3	Taranto	1912		5281t, 138.7x13.5x5.1m, 16b,2t, 27000hp, 27.5kts, 486p; 60belt, 40/60deck, 50shields, 100CT; 7x1-150/43, 2x1-76/40, (2+2x1)-500TT, 120m, 1seaplane (M.7)
	Brindisi	1 4	Venezia	1914		4327t, 130.6x12.8x5.3m, 16b,2t, 25600hp, 27kts, 368p; 60belt, 20deck, 40shields, 50CT; 9x1-100/47, 1x1-37/43, 2x2- 533TT, 120m
	Ancona	1 5	Ancona	1914		6382t, 142.7x13.8x6.1m, 12b,2t, 26000hp, 27kts, 385p; 60belt, 40/60deck, 50shields, 100CT; 7x1-150/43, 3x1-76/40, 4x1-500TT, 120m, 1seaplane (M.7)
	Bari	1 6	Bari	1914		5305t, 135.3x13.6x6.0m, 10b,2t, 28000hp, 28kts, 440p; 80deck, 50shields, 75CT; 8x1-150/43, 3x1-76/40, 2x1-500TT, 120m

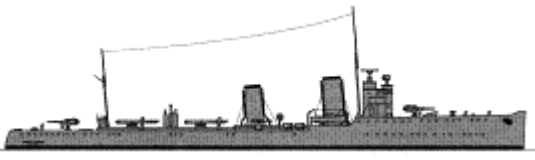
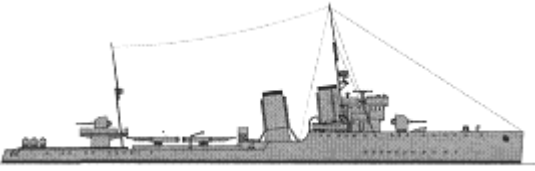
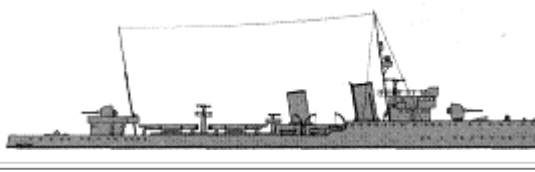
TORPEDO SHIPS

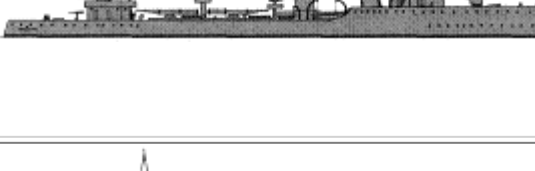
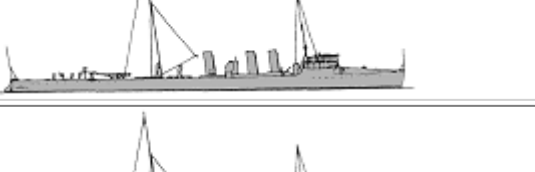
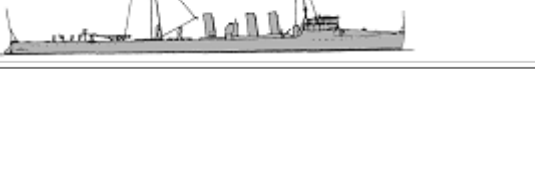



		1	Carlo Mirabello	1916	
Mirabello	2	2	Augusto Riboty	1917	1972t, 103.4x9.7x3.3m, 4b,2t, 44000hp, 35kts, 169p; 8x1-102/45, 2x1-40/39, 2x2-450TT, 100m(1), 120m(2)

DL							
	Aquila	2	3	Aquila	1917		1733(3)-1760(4)t, 94.7x9.5x3.6m, 5b,2t, 40000hp, 146p; 2x2-120/45, 2x1-76/40, 2x2-450TT, 44m(3), 38m(4)
			4	Falco	1920		
	Pemuda	1	5	Pemuda	1918		2555t, 107.5x10.4x3.8m, 4b,2t, 45000hp, 34.5kts, 162p; 4x1-150/42, 2x1-40/39, 2x2-600TT, 40m
	Rossarol	1	6	Cesare Rossarol	1915		1756t, 98.0x9.4x3.9m, 4b,2t, 40000hp, 36.5kts, 114p; (1x2+1x1)-120/45, 2x1-76/40, 2x2-500TT, 29m
	Leone	3	7	Leone	1924		2289t, 113.4x10.3x3.2m, 4b,2t, 42000hp, 34kts, 204p; 4x2-120/45, 2x1-76/40, 2x3-450TT, 60m
			8	Pantera	1924		
			9	Tigre	1924		
	Navigatori	4	10	Antonio da Noli	1929		2580t, 107.3x10.2x3.4m, 4b,2gt, 50000hp, 38kts, 224p; 3x2-120/50, 2x1-40/39, 2x2-13.2, 2x(2-533+1-450)TT, 2DCT, 56m
			11	Leone Pancaldo	1929		
			12	Luca Tarigo	1929		
			13	Antonio Usodimare	1929		
	Poerio	2	1	Alessandro Poerio	1915		1216t, 85.0x8.0x2.8m, 3b,2t, 20000hp, 31.5kts, 129p; 5x1-102/45(1), 6x1-102/45(2), 1x1-40/39(1), 2x1-40/39(2), 2x2-450TT, 42m
2			Guglielmo Pepe	1915			
Ardimentoso	1	3	Ardimentoso	1916		1130t, 83.1x8.4x3.6m, 3b,2t/1t(2), 24000hp, 34kts, 111p; 3x1-100/47, 2x1-40/39, 2x2-500TT, 24m	
Palestro	4	4	Palestro	1921		1076t, 81.9x8.0x2.7m, 4b,2t, 18000hp, 32kts, 118p; 4x1-102/45, 2x1-76/40, 2x2-450TT, 38m	
		5	Confienza	1923			
		6	San Martino	1922			
		7	Solferino	1921			

DD	Curtatone	4	8	Calatafimi	1924		1214t, 84.7x8.0x2.9m, 4b,2t, 22000hp, 32kts, 117p; 2x2-102/45, 2x1-76/30, 2x3-450TT, 16m														
			9	Castelfidardo	1924																
			10	Curtatone	1923																
			11	Monzambano	1924																
	Sella	4	12	Francesco Crispi	1927		1457t, 84.9x8.6x2.7m, 3b,2gt, 36000hp, 35kts, 152p; 2x2-120/45, 2x1-40/39, 2x1-13.2, 2x2-533TT, 2DCT, 32m														
			13	Quintino Sella	1926																
			14	Bettino Ricasoli	1926																
			15	Giovanni Nicotera	1927																
	Sauro	4	16	Cesare Battisti	1927		1575t, 90.2x9.2x2.9m, 3b,2gt, 36000hp, 35kts, 155p; 2x2-120/45, 2x1-40/39, 2x1-13.2, 2x3-533TT, 2DCT, 52m														
			17	Daniele Manin	1927																
			18	Francesco Nullo	1927																
			19	Nazario Sauro	1926																
	Turbine	8	20	Aquilone	1927		1670t, 93.2x9.2x3.0m, 3b,2gt, 40000hp, 36kts, 179p; 2x2-120/45, 2x1-40/39, 1x2-13.2, 2x3-533TT, 52m														
			21	Borea	1927																
			22	Espero	1928																
			23	Euro	1927																
			24	Nembo	1927																
			25	Ostro	1928																
			26	Turbine	1927																
			27	Zeffiro	1928																
	Soldati-2	1	1	Fuciliere	1910		424t, 65.0x6.1x2.1m, 3b,2vte, 6000hp, 28.5kts, 50p; 4x1-76/40, 3x1-450TT, 10m														
								Ascaro	1	2	Ascaro	1913		414t, 65.0x6.1x2.1m, 3b,2vte, 6000hp, 28.5kts, 55p; 4x1-76/40, 3x1-450TT, 10m							
															1PN	10	3	7PN	1912		143t, 42.5x4.6x1.5m, 2b,2vte, 3200hp, 27kts, 30p; 1x1-76/40, 1x1-76/30, 2x1-450TT, 10m(3,8)
																	4	9PN	1912		
																	5	12PN	1913		
																	6	15OS	1912		
																	7	19OS	1912		
8																	29AS	1913			
9																	33PN	1913			
10																	34PN	1913			
11	35PN	1913																			
12	38PN	1913																			
Indomito	4	13	Indomito	1913		900t, 73.0x7.3x2.4m, 4b,2t, 16000hp, 28kts, 79p; 5x1-102/35, 1x1-40/39, 2x2-450TT, 10m															
		14	Impavido	1913																	
		15	Insidioso	1914																	

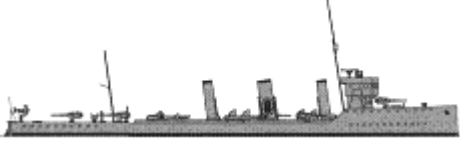
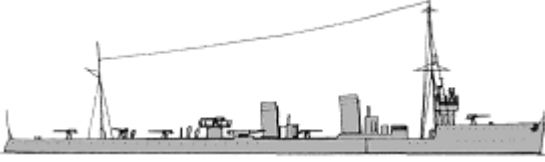
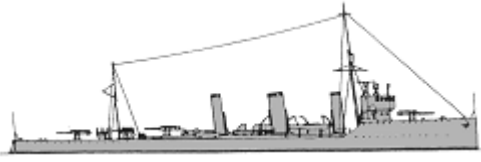



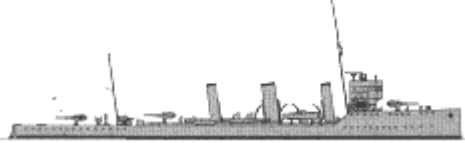



		16	Irrequeto	1913		
Ardito	2	17	Ardito	1913		900t, 73.0x7.3x2.4m, 4b,2t, 16000hp, 28kts, 69p; 5x1-102/35, 1x1-40/39, 2x2-450TT, 10m
		18	Ardente	1914		
Pilo	8	19	Rosolino Pilo	1915		912t, 73.0x7.3x2.3m, 4b,2t, 16000(9-12,14,16)-14800(13,15)hp, 30(9-12,14,16)-29(13,15)kts, 79p; 5x1-102/35, 2x1-40/39, 4x1-450TT, 10m
		20	Giuseppe Cesare Abba	1915		
		21	Giuseppe Dezza	1916		
		22	Giuseppe Missori	1916		
		23	Antonio Mosto	1915		
		24	Ippolito Nievo	1915		
		25	Fratelli Cairoli	1915		
		26	Simone Schiaffino	1915		
40PN	28	27	41PN	1916		168t, 42.5x4.6x1.6m, 2b,2vte, 2700hp, 27kts, 30p; 2x1-76/30, 1x1-37/43(32-38,40,44-46), 1x2-450TT, 10m
		28	42PN	1916		
		29	43PN	1916		
		30	44PN	1916		
		31	45PN	1916		
		32	46OS	1916		
		33	47OS	1916		
		34	48OS	1916		
		35	49OS	1916		
		36	50OS	1916		
		37	51OS	1916		
		38	52AS	1916		
		39	53AS	1916		
		40	54AS	1916		
		41	55AS	1916		
		42	56AS	1916		
		43	57AS	1916		
		44	58OL	1916		
		45	59OL	1916		
		46	60OL	1916		
		47	61OL	1916		
		48	62OL	1916		
		49	63OL	1916		
		50	64PN	1917		
		51	65PN	1918		
		52	70PN	1918		
		53	71PN	1918		



		54	69PN	1918		
Sirtori	4	55	Giuseppe Sirtori	1916		850t, 73.5x7.3x2.8m, 4b,2t, 15500hp, 30kts, 85p; 6x1-102/45, 2x1-40/39, 2x2-450TT, 10m
		56	Giovanni Acerbi	1917		
		57	Vincenzo Giordano Orsini	1917		
		58	Francesco Stocco	1917		
Audace	1	59	Audace	1917		1170t, 87.5x8.3x2.5m, 3b,2t, 22000hp, 30kts, 118p; 7x1-102/35, 2x1-40/39, 2x2-450TT
La Masa	7	60	Giuseppe La Masa	1919		851t, 73.5x7.3x2.8m, 4b,2t, 15500hp, 30kts, 78p; 4x1-102/45, 2x1-76/40, 2x2-450TT, 10m
		61	Angelo Bassini	1918		
		62	Enrico Cosenz	1919		
		63	Giacinto Carini	1917		
		64	Nicola Fabrizzi	1918		
		65	Giuseppe La Farina	1919		
66	Giacomo Medici	1918				
70OLT	2	67	74OLT	1918		195t, 45.7x4.6x1.8m, 2b,2t, 3500hp, 27kts, 31p; 2x1-76/30, 1x2-450TT, 7m
		68	75OLT	1918		
Fasana	1	69	Pola	1914		1000t, 83.5x7.8x2.4m, 6b,2t, 20640hp, 32.6kts, 105p; 2x1-100/47, 6x1-66/47, 2x2-450TT
Grado	3	70	Cortelazzo	1917		1045t, 85.4x7.8x2.4m, 6b,2t, 22360hp, 32.6kts, 114p; 2x1-100/47, 6x1-66/47, 2x2-450TT
		71	Grado	1917		
		72	Monfalcone	1918		
Generali	6	73	Generale Antonio Cantore	1921		870t, 73.5x7.3x2.7m, 4b,2t, 15500hp, 30kts, 118p; 3x1-102/45, 2x1-76/40, 2x2-450TT, 2DCT
		74	Generale Antonio Cascino	1922		
		75	Generale Antonio Chinotto	1921		
		76	Generale Carlo Montanari	1922		
		77	Generale Achille Papa	1922		
		78	Generale Marcello Prestinari	1922		

## SUBMARINES

		1	F1	1916
--	--	---	----	------

F	8	2	F6	1917		262/319t, 45.6x4.2x3.1m, 2d/em, 670/500hp, 12.5/8.2kts, 26p, 40m; 1x1-76/30, 2-450TT
		3	F10	1916		
		4	F13	1917		
		5	F18	1917		
		6	F19	1918		
		7	F20	1918		
		8	F21	1918		
		H	7	9		
10	H2			1916		
11	H3			1917		
12	H4			1917		
13	H6			1917		
14	H7			1917		
15	H8			1918		
Micca	5	16	Pietro Micca	1918		842/1244t, 63.2x6.2x4.3m, 2d/em, 2900/1800hp, 11/10.9kts, 40p, 50m; 1x1-76/40, 1x1-76/30, 6-450TT
		17	Angelo Emo	1919		
		18	Luigi Galvani	1918		
		19	Lazzaro Mocenigo	1920		
		20	Torricelli	1918		
SS	1	21	Giacomo Nani	1919		762/924t, 67.0x5.9x3.8m, 2d/em, 2600/1400hp, 16/9.8kts, 40p, 50m; 2x1-76/40, 6-450TT
N	4	22	N1	1918		277/363t, 45.8x4.3x3.2m, 2d/em, 650(22-24)-820(25)/450hp, 12.5(22-24)-13.5(25)/7.9kts, 23p, 40m; 1x1-76/30, 2-450TT
		23	N3	1918		
		24	N4	1919		
		25	N6	1919		
X2	2	26	X2	1918		403/468t, 42.6x5.5x3.2m, 2d/em, 650/325hp, 8.2/6.3kts, 25p, 40m; 1x1-76/30, 2-450TT, 18m
		27	X3	1918		
Balilla	4	28	Balilla	1928		1427/1874t, 86.5x7.8x4.7m, 2d+1dg/em, 4900+425/2200hp, 16/7kts, 77p, 90m; 1x1-120/27, 2x1-13.2, 6-533TT, 4m(28,29,31)
		29	Domenico Millelire	1928		
		30	Antonio Sciesa	1929		
		31	Enrico Toti	1928		
Mameli	4	32	Pier Capponi	1929		810/993t, 64.6x6.5x4.3m, 2d/em, 3000/1100hp, 17.2/7.7kts, 49p, 100m; 1x1-102/35, 2x1-13.2, 6-533TT
		33	Giovanni da Procida	1929		
		34	Goffredo Mameli	1929		
		35	Tito Speri	1929		
Pisani	4	36	Giovanni Bausan	1929		866/1040t, 68.2x6.1x4.9m, 2d/em, 3000/1100hp, 17.3/8.8kts, 48p, 90m; 1x1-102/35, 2x1-13.2, 6-533TT
		37	Marcantonio Colonna	1929		
		38	Des Geneys	1929		



## ESCORTS

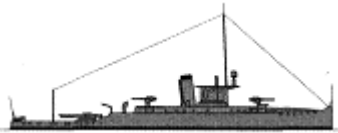



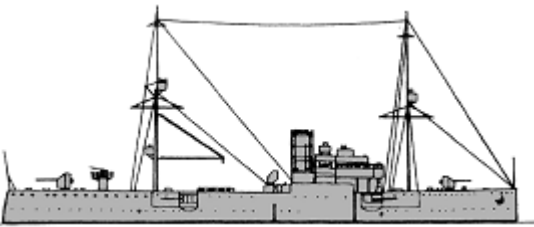

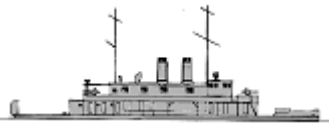



PC	Bafile	5	1	Andrea Bafile	1922		284t, 52.1x5.7x1.8m, 2b,2vte, 2400hp, 24kts, 53p; 2x1-102/35, 1x2-450TT, 12m
			2	Carlo del Greco	1922		
			3	Tolosetto Farinati	1922		
			4	Ernesto Giovannini	1922		
			5	Alessandro Vitturi	1922		
APC	-	21	1	Maggiore Toselli	1912		370t
			2	Cirene	1912		500t; 2x1-76/40
			3	Porto Corsini	1912		380t; 2x1-76/40
			4	Rimini	1912		420t; 2x1-76/40
			5	Alula	1912		430t; 1x1-76/40
			6	Gallipoli	1911		400t; 2x1-76/40
			7	Otranto	1911		385t; 2x1-76/40
			8	Augusta	1911		390t; 2x1-76/30
			9	Valoroso	1913		420t; 2x1-76/40
			10	Balena	1911		286t; 1x1-76/40
			11	Basiluzzo	1915		110t
			12	Burrasca	1912		280t; 1x1-76/40
			13	Gaeta	1916		250t; 1x1-76/40
			14	Lampedusa	1915		166t; 1x1-76/40
			15	Lilibeo	1915		124t
			16	Liscanera	1916		222t; 1x1-76/40
			17	Porto d'Anzio	1914		166t; 1x1-76/40
			18	Portofino	1915		270t; 1x1-76/40
			19	Talamone	1916		190t; 1x1-76/40
			20	Terracina	1916		230t; 1x1-76/40
			21	Vigilante	1906		316t; 1x1-76/40

## OTHER FIGHTING SHIPS



PG	Sebastiano Caboto	1	1	Sebastiano Caboto	1912	No picture	1050t, 63.4x9.7x3.0m, 2b,2vte, 1200hp, 13.2kts, 107p; 6x1-76/40
	Campania	1	2	Campania	1917		3187t, 83.0x12.7x5.2m, 4b,2vte, 5000hp, 15.7kts, 204p; 25deck, 50CT; 4x1-152/40, 5x1-76/40
			1	Abisso	1912		400t; 2x1-76/40
			2	Generale Arimondi	1910		580t; 1x1-76/40



APG	-	4	3	Boeo	1916		235t; 1x1-76/40
			4	Palmaiola	1902		562t; 1x1-76/40
PR	Carlotto	1	1	Ermanno Carlotto	1921		218t, 48.8x7.5x0.9m, 2b,2vte, 1100hp, 14kts, 44p; 2x1-76/40

## COASTAL FORCES

PT	12t A-1 SVAN	1	1	MAS15	1916		16t, 16.0x2.6x1.2m, 2pe/em, 450/10hp, 23/4kts, 8p; 2-450TT, 1DCR
	12t A-1 Orlando	3	2-4	MAS92, 94, 100	1917 - 1918		13t, 16.2x2.8x1.4m, 2pe/em, 500/10hp, 29.5/4kts, 8p; 2-450TT, 1DCR
	12t A-1 Baglietto	7	5 - 11	MAS204, 206, 208, 210, 212, 213, 216	1918		14t, 16.0x2.6x1.1m, 2pe, 700hp, 27kts, 7p; 2-450TT, 2DCR
	12t A-2 Orlando	6	12 - 17	MAS219, 222, 223, 228-230	1918		13t, 16.4x2.9x1.4m, 2pe/em(12,13,15)-2pe(14,16,17), 500/10(12,13,16)-500(14,16,17)hp, 26/4(12,14,16)-26(14,16,17)kts, 8p; 2-450TT, 1DCR
	12t mod. A-1 SVAN	1	18	MAS320	1919		14t, 16.0x2.9x1.2m, 2pe, 700hp, 28kts, 8p; 2-450TT, 1DCR
	D-1 Baglietto	4	19 - 22	MAS397-400	1920 - 1924		27t, 21.2x4.2x1.2m, 3pe/2em(3), 1900/10hp, 33/4kts, 12p; 2-450TT, 2DCR
	D-2 SVAN	2	23, 24	MAS418, 422	1922 - 1923		21t, 18.0x3.6x1.2m, 3pe/2em(3), 1200/16hp, 26.5/5kts, 10p; 2-450TT, 1DCR
	SVAN 1923	3	25 - 27	MAS427-429	1925 - 1927	No picture	31(25,26)-30(27)t, 24.0(25,26)-22.0(27)x4.0x1.3m, 3pe, 1200hp, 26(25,26)-28(27)kts, 11p; 1x1-76/30, 2-450TT, 2DCR
	13t SVAN	3	28 - 30	MAS423-425	1928 - 1929		13t, 16.0x3.0x1.0m, 2pe, 1500hp, 40kts, 9p; 2-450TT
	14t SVAN	1	31	MAS430	1929		14t, 16.0x3.3x1.0m, 2pe, 1500hp, 40kts, 9p; 2-450TT, 1DCR
PG	12t mod. A-1 SVAN	5	1 - 5	MAS178, 179, 188, 190, 200	1918 - 1919		12t, 16.0x2.6x1.1m, 2pe, 480hp, 25kts, 8p; 1x1-57/43, 1DCR
	12t A-mod. SVAN	2	6, 7	MAS141, 145	1918		12t, 16.0x2.6x1.1m, 2pe, 400(6)-480(7)hp, 24(6)-25(7)kts, 8p; 1x1-57/43, 1DCR

## MINE WARFARE SHIPS

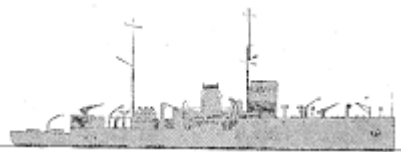
ML	Brondolo	2	1	Brondolo	1909		117t, 38.1x6.3x0.8m, 1b,2vte, 500hp, 13kts, 18p; 1x1-76/40, 20m	
			2	Marghera	1909			
	Fasana	4	3	Fasana	1925		590t, 66.3x9.8x1.7m, 2d, 700hp, 10kts, 66p; 1x1-76/40, 54m, MS	
			4	Durazzo	1926			
			5	Buccari	1927			
			6	Pelagosa	1927			
				7	Dardanelli	1926		
				8	Milazzo	1926		
				9	Ostia	1926		

MS	Ostia	6					850t, 62.2x8.7x2.6m, 2b,2vte, 1500hp, 15kts, 66p; 2x1-102/35, 1x1-76/40, 80m, MS
			10	Legnano	1927		
			11	Azio	1928		
			12	Lepanto	1928		
	RD1	39	1	RD4	1917		196-302t, 34.0-38.0x5.8-7.2x1.9-2.5m, 1b,1vte, 590-1150hp, 10-14kts, 22p; 1x1-76/40, MS
			2	RD6	1917		
			3	RD7	1917		
			4	RD9	1917		
			5	RD11	1917		
			6	RD12	1917		
			7	RD13	1918		
			8	RD16	1917		
			9	RD17	1917		
			10	RD18	1917		
11			RD20	1917			
12			RD21	1918			
13			RD22	1918			
14			RD23	1918			
15			RD24	1918			
16			RD25	1918			
17			RD26	1918			
18			RD27	1918			
19			RD28	1918			
20			RD29	1919			
21			RD30	1919			
22			RD31	1919			
23			RD32	1919			
24			RD33	1919			
25			RD34	1919			
26			RD35	1919			
27			RD36	1919			
28			RD37	1920			
29			RD38	1921			
30			RD39	1919			
31			RD40	1920			
32			RD41	1920			
33	RD42	1920					
34	RD43	1920					
35	RD44	1920					
36	RD49	1922					

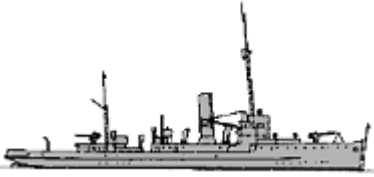
		37	RD55	1925		
		38	RD56	1925		
		39	RD57	1926		
RD58	3	40	Albona	1920		145t, 31.8x6.5x1.7m, 1b,2vce, 280hp, 11kts, 27p; 1x1-76/40, 34m, MS
		41	Laurana	1920		
		42	Rovigno	1920		
Meteo	2	43	Vieste	1918		560t, 59.6x7.3x2.2m, 2b,2vte, 1850hp, 16kts, 40p; 2x1-105/42, 30m, MS
		44	Crotone	1918		

NAVAL AVIATION (*approximately, maximal number of delivered planes signed*)

Seaplanes	F: 100 M.7ter, 29 M.7ter AR, 46 CR.20idro, 25 M.41bis; B: ~20 M.18, ~20 M.18 AR; R: 15 P.6ter
-----------	---



[home](#)

[World navies yesterday](#)

[1930](#)

# JAPAN 01 January 1930

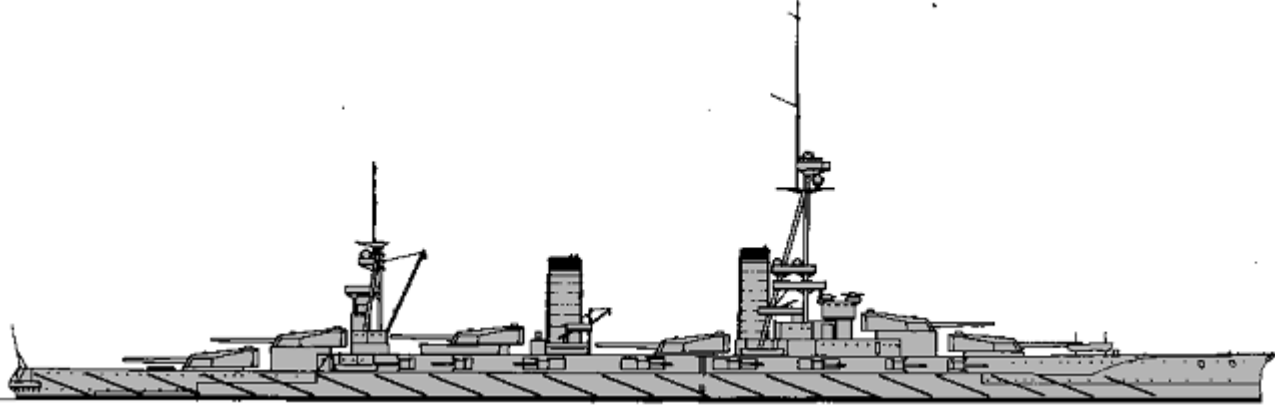
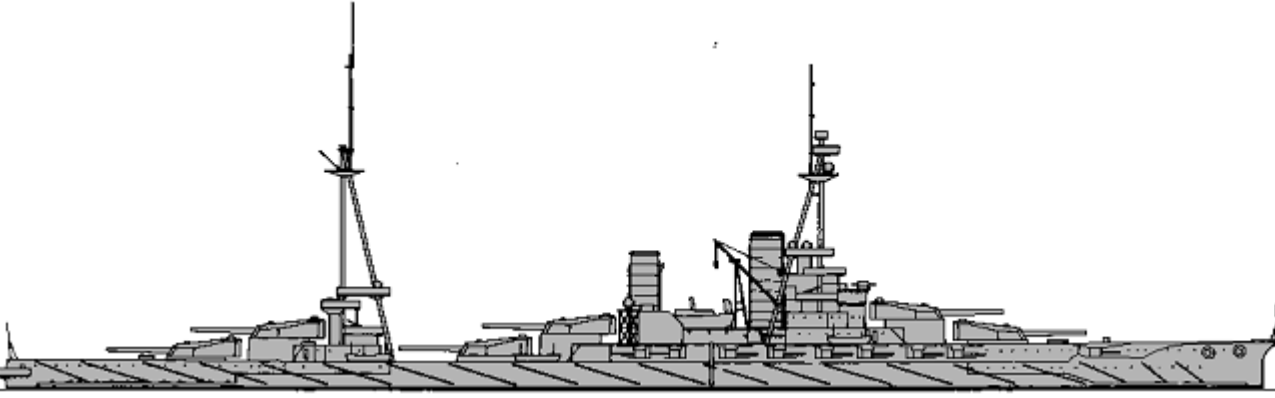
## CAPITAL SHIPS

		1	Fuso	1915		<p>35900(1)-39154(2)t, 205.1x28.7x8.7m, 24b, 4t, 40000hp, 22.5kts, 1193p; 305belt, 76deck, 305turrets, 350CT; 6x2-356/45, 16x1-152/50, 6x1-76/40, 6-533TT</p>
Fuso	2	2	Yamashiro	1917		
BB	Ise	3	Ise	1917		<p>36500t, 208.2x28.7x8.8m, 24b, 4t, 45000hp, 23kts, 1360p; 305belt, 51deck, 305turrets, 305CT; 6x2-356/45, 20x1-140/50, 4x1-76/40, 6-533TT</p>
		4	Hyuga	1918		
Nagato	2	5	Nagato	1920		<p>38500t, 215.8x29.0x9.1m, 21b, 4gt, 80000hp, 26.5kts, 1333p; 305b, 121deck, 356turrets, 356CT; 4x2-410/45, 20x1-140/50, 7x1-76/40(5), 4x1-76/40(6), 8-533TT</p>
		6	Mutsu	1921		

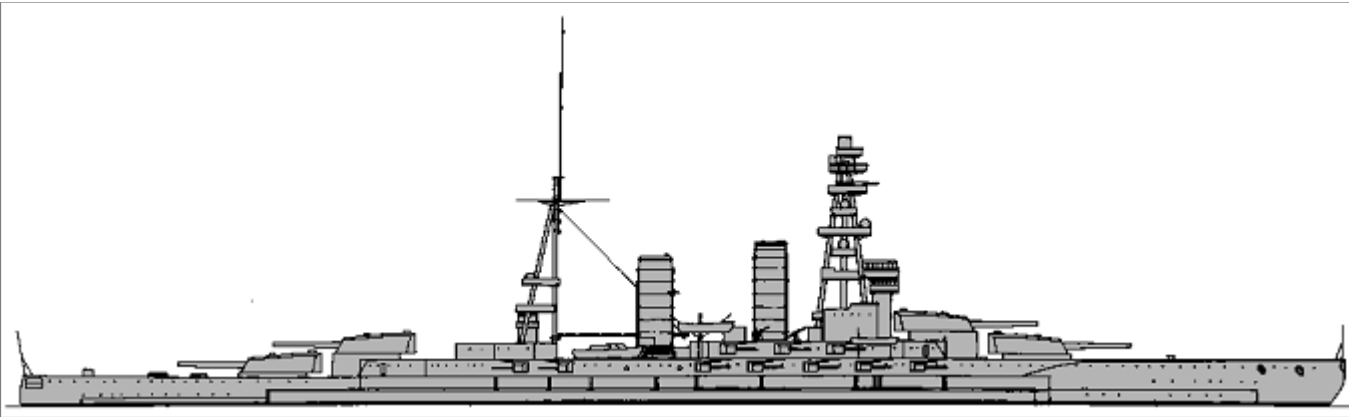
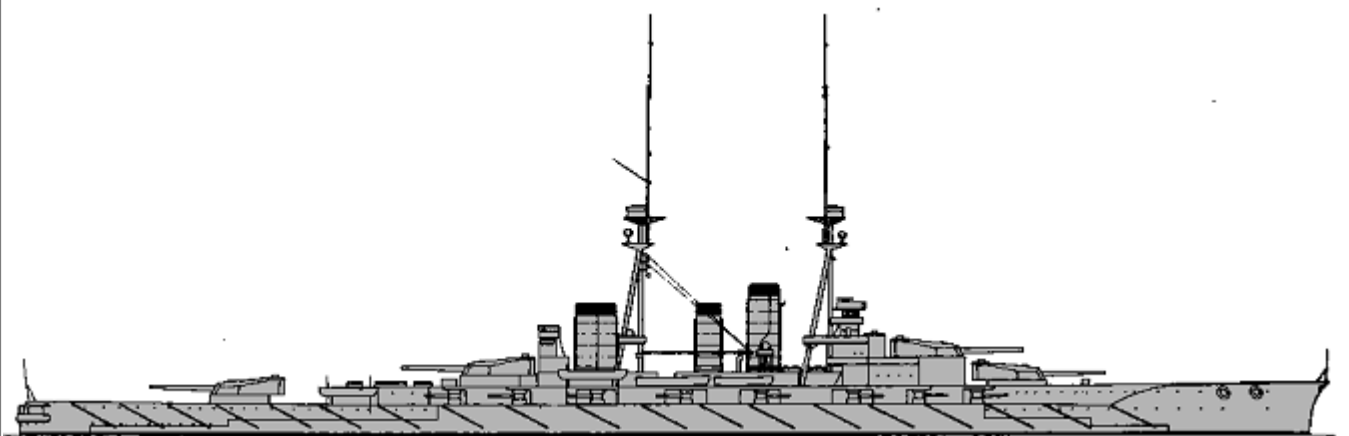
						
BC	Kongo	1	Kongo	1913		32200(1-3)-31475(4)t, 214.5(1-3)-215.2(4)x28.0(1-3)-29.3(4)x8.4(1-3)-8.6(4)m, 36b(1-3)-16b(4), 4t, 64000hp, 27.5(1-3)-25.9(4)kts, 1201-1221(1-3)-1118(4)p; 203belt, 57(1-3)-120(4)deck, 229turrets, 254CT; 4x2-356/45, 16x1-152/50, 7x1-76/40, 8-533TT(1-3), 4-533TT(4)
		2	Hiei	1914		
		3	Kirishima	1915		
		4	Haruna	1915		

### AIRCRAFT CARRYING SHIPS

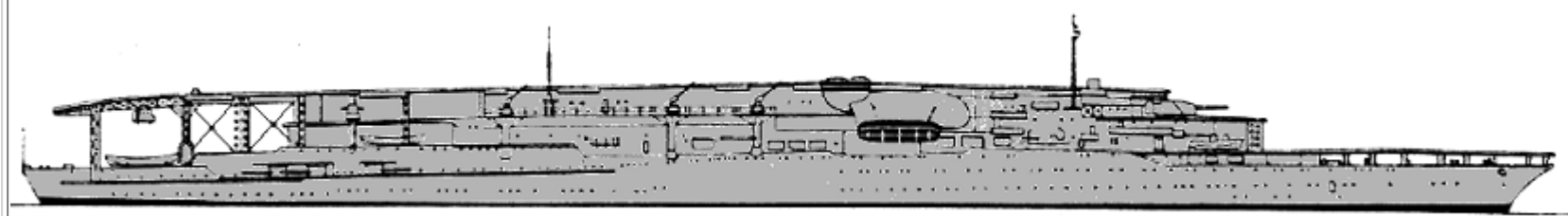
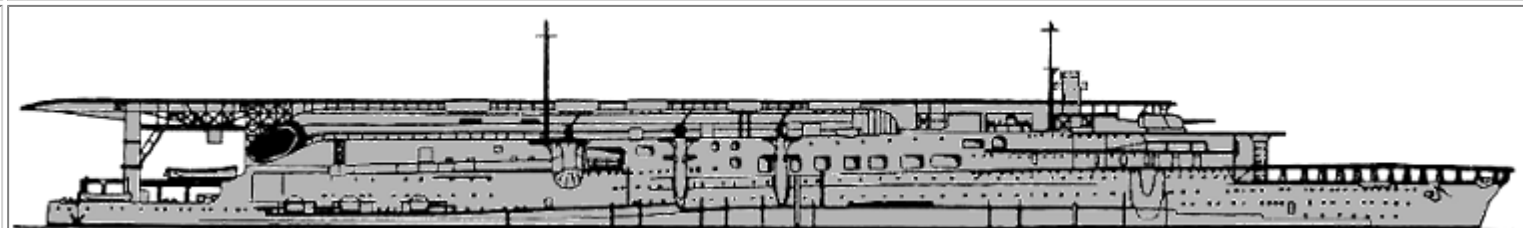
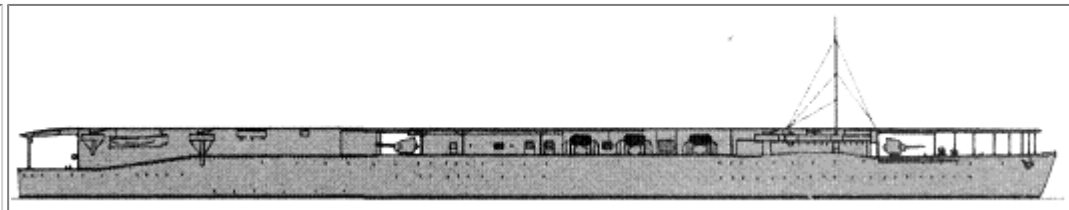

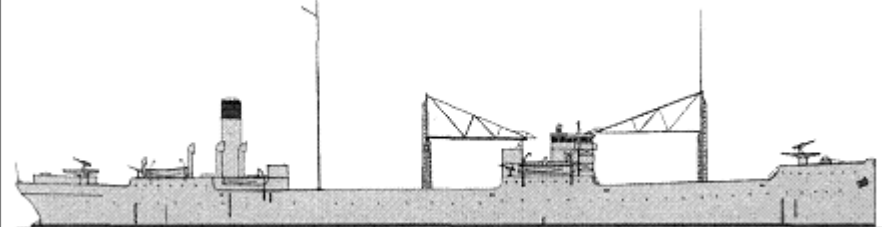
CV	Akagi	1	1	Akagi	1927		34364t, 260.7x29.0x8.1m, 19b, 4gt, 131200hp, 31kts, 1650p; 152belt, 51deck, 25turrets; (2x2+6x1)-200/50, 6x2-120/45, 60aircraft (16 A1N, 28 B1M, 16 C1M)
	Kaga	1	2	Kaga	1928		33693t, 238.5x29.6x7.9m, 12b, 4gt, 91000hp, 27.5kts, 1340p; 152belt, 55deck, 25turrets; (2x2+6x1)-200/50, 6x2-120/45, 60aircraft (15 A1N, 24 B1M, 8 C1M)
CVL	Hosho	1	1	Hosho	1922		9630t, 168.1x22.7x6.2m, 8b, 2t, 30000hp, 25kts, 550p; 4x1-140/50, 4x1-76/40, 26aircraft (9 A1N, 3 B1M, 3 C1M)
							7720t, 111.3x14.7x5.8m,

AV	Wakamiya	1	1	Wakamiya	1901		3b, 1vte, 1590hp, 10kts, 234p; 2x1-76/40, 2x1-47/40, 4seaplanes (really none)
	Notoro	2	3	Notoro	1920		14050t, 138.9x17.7x8.1m, 4b, 2vte, 5850hp, 12kts, 155p; 2x1-120/45, 2x1-76/40, 10seaplanes (E1Y, E2N and E3A)
				Tsurumi	1922		

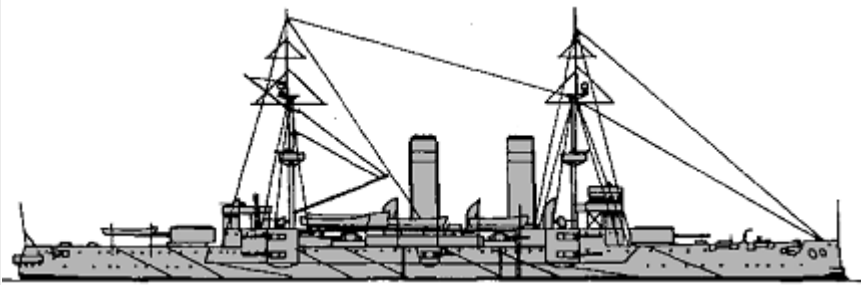
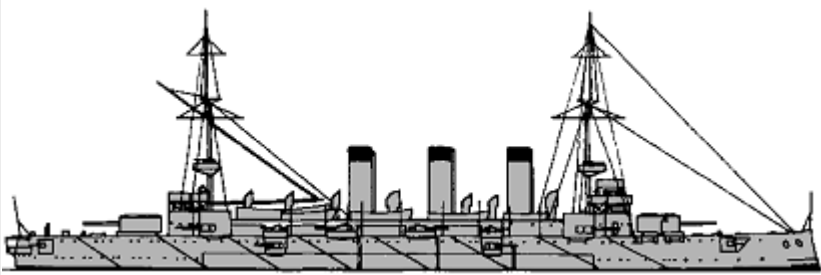
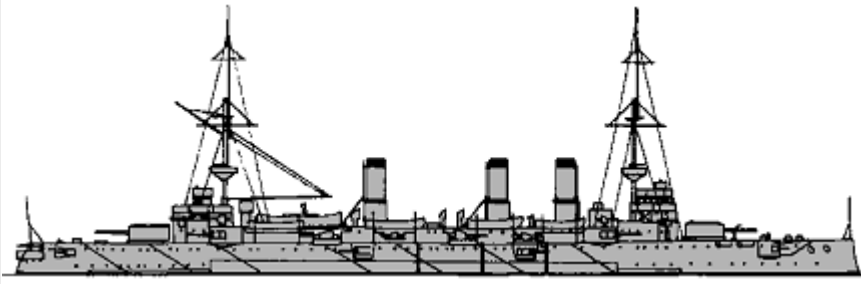
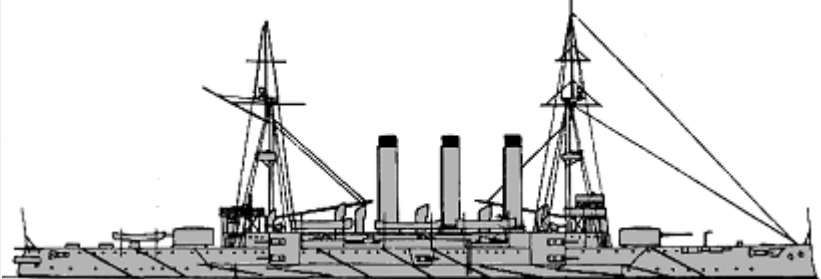
### CRUISERS

CA	Asama	1	1	Asama	1899		10500t, 134.7x20.5x7.4m, 16b, 2vte, 18000hp, 21.5kts, 726p; HN 178belt, 76deck, 152turrets, 356CT; 2x2-203/45, 14x1-152/40, 9x1-76/40, 3x1-47/30, 2-450TT
	Yakumo	1	2	Yakumo	1900		10300t, 132.3x19.6x7.2m, 6b, 2vte, 7000hp, 16kts, 700p; 178belt, 63deck, 152turrets, 356CT; 2x2-203/45, 8x1-152/40, 1x1-76/40
	Azuma	1	3	Azuma (TS)	1900		9953t, 137.9x20.9x7.2m, 24b, 2vte, 17000hp, 20kts, 650p; 178belt, 63deck, 152turrets, 356CT; 2x2-203/45, 12x1-152/40, 9x1-76/40, 8x1-47/40, 2-450TT
	Izumo	2	5	Izumo	1900		10300t, 132.3x20.9x7.4m, 24b, 2vte, 14500hp, 20.8kts, 672p; 178belt, 63deck, 152turrets, 356CT; 2x2-203/45, 14x1-152/40, 9x1-76/40, 4x1-47/30, 2-450TT
				Iwate	1901		

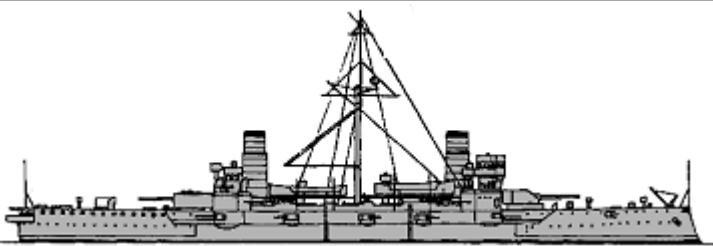
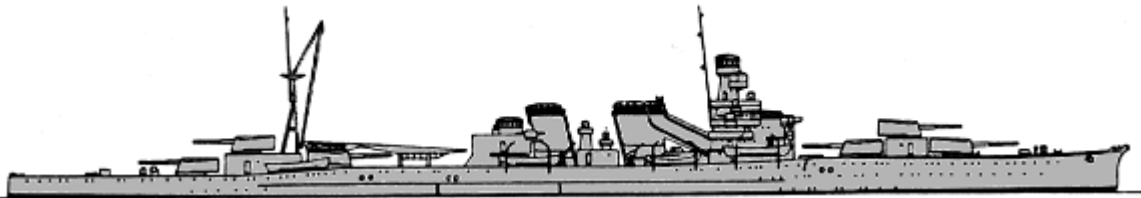
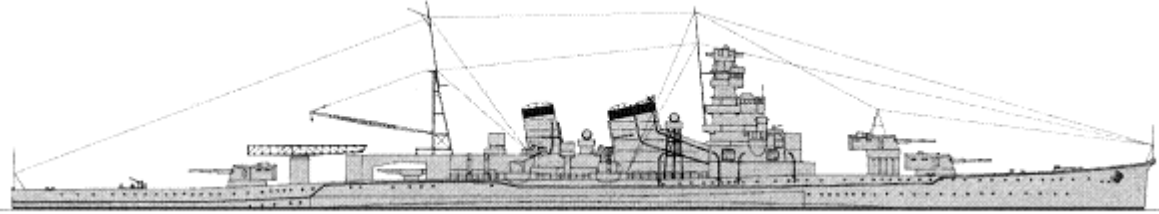
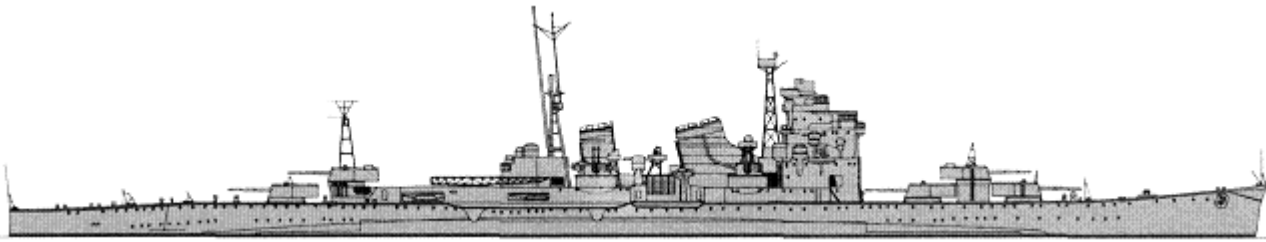
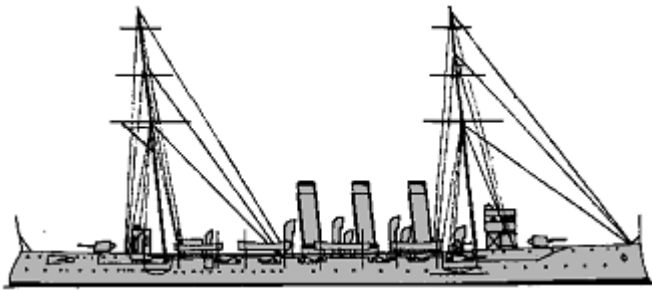
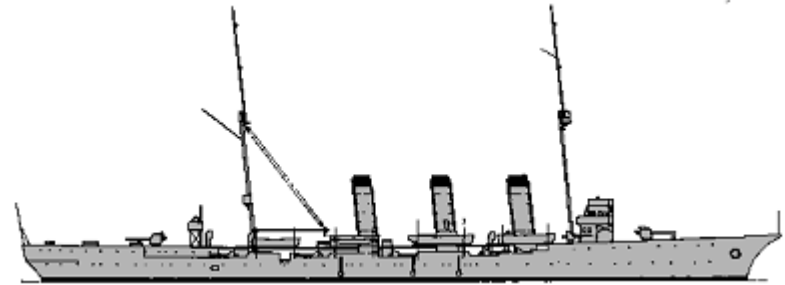





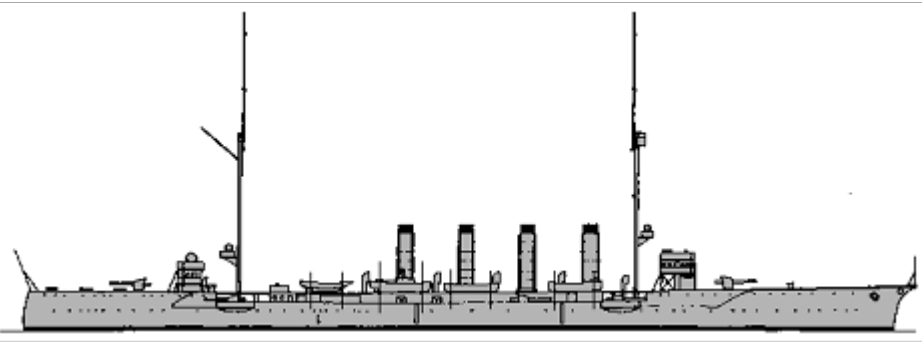
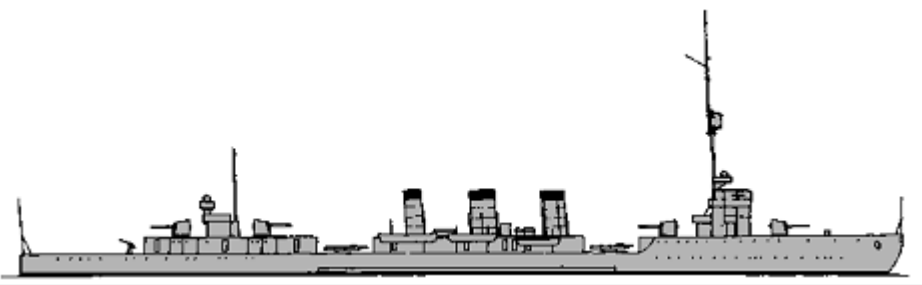
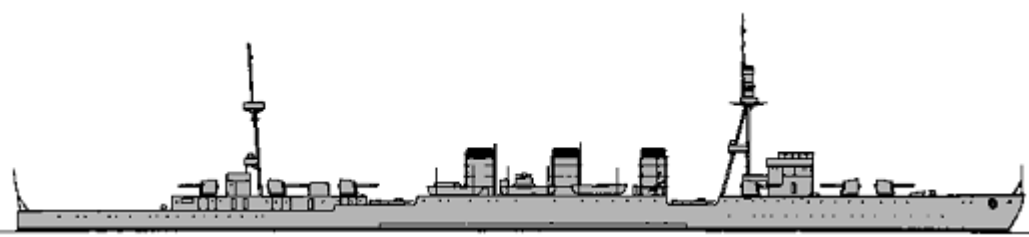
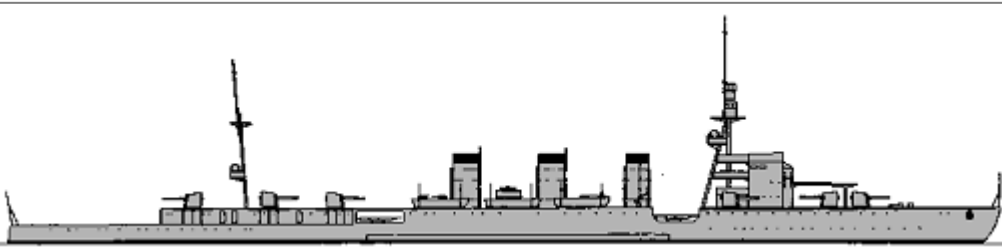
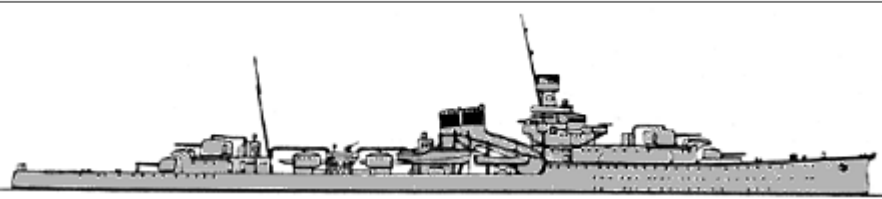
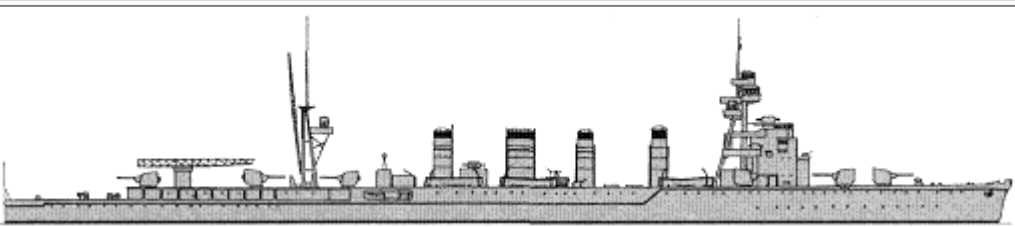

Kasuga	2	6	Kasuga	1904		8500t, 111.7x18.9x7.3m, 12b, 2vte, 13500hp, 20kts, 600p; 150belt, 38deck, 150turrets, 150CT; 1x1-254/40(5), 1x2-203/45(5), 2x2-203/45(6), 4x1-152/40, 5x1-76/40, 4-450TT
		7	Nisshin	1904		
Furutaka	2	8	Furutaka	1926		9544t, 185.2x15.8x5.6m, 12b, 4gt, 102000hp, 34.5kts, 625p; 76belt, 35deck, 25turrets; 6x1-200/50, 4x1-76/40, 12-610TT, 1seaplane (HD.25)
		9	Kako	1926		
Aoba	2	10	Aoba	1927		9820t, 185.2x15.8x5.7m, 12b, 4gt, 102000hp, 34.5kts, 625p; 76belt, 35deck, 25turrets; 3x2-200/50, 4x1-120/45, 12-610TT, 1seaplane (E2N)
		11	Kinugasa	1927		
Nachi	4	12	Nachi	1928		13280t, 203.8x17.3x5.9m, 12b, 4gt, 130000hp, 35.5kts, 773p; 102belt, 90deck, 25turrets; 5x2-200/50, 6x1-120/45, 12-610TT, 2seaplanes (E2N)
		13	Myoko	1929		
		14	Haguro	1929		
		15	Ashigara	1929		
Tsushima	1	1	Tsushima	1904		3716t, 104.1x13.4x4.9m, 16b, 2vte, 9500hp, 20kts, 320p; HN 64slopes, 25shields, 102CT; 6x1-152/40, 9x1-76/40
Tone	1	2	Tone	1910		4900t, 113.8x14.4x5.1m, 16b, 2vte, 15000hp, 23kts, 370p; 76deck, 25shields, 102CT; 2x1-152/45, 8x1-120/40, 6x1-76/40, 3-450TT
Chikuma	3	3	Chikuma	1912		5040t, 144.8x14.2x5.1m, 6b, 2t, 22500hp, 26kts, 414p; 89belt, 57deck, 25shields, 102CT; 8x1-152/45, 6x1-76/40,
		4	Hirado	1912		





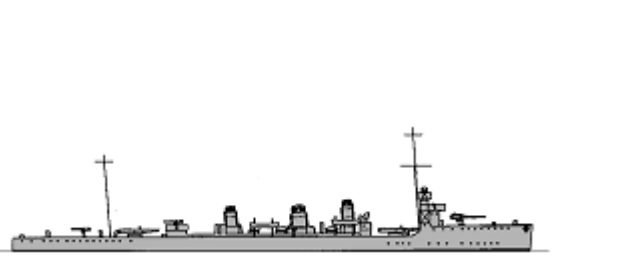

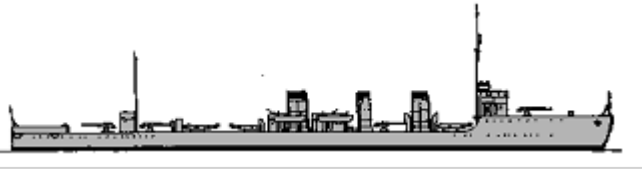
		5	Yahagi	1912		2x2-533TT
CL	Tenryu	6	Tenryu	1919		4350t, 142.9x12.3x4.0m, 10b, 3gt, 51000hp, 33kts, 327p; 63belt, 25deck, 20shields, 51CT; 4x1-140/50, 1x1-76/40, 2x3-533TT, 48mines
		7	Tatsuta	1919		
Kuma	5	8	Kuma	1920		5832t, 162.2x14.2x4.8m, 12b, 4gt, 90000hp, 36kts, 450p; 63belt, 45deck, 20shields, 51CT; 7x1-140/50, 2x1-76/40, 4x2-533TT, 48mines
		9	Tama	1921		
		10	Kitakami	1921		
		11	Oi	1921		
		12	Kiso	1921		
Nagara	6	13	Nagara	1922		7050t, 162.2x14.2x4.8m, 12b, 4gt, 90000hp, 36kts, 450p; 63belt, 20shields, 29deck, 51CT; 7x1-140/50, 2x1-76/40, 4x2-610TT, 48mines, 1seaplane (E2N)
		14	Natori	1922		
		15	Kinu	1922		
		16	Isuzu	1923		
		17	Yura	1923		
		18	Abukuma	1925		
Yubari	1	19	Yubari	1923		4400t, 138.9x12.0x3.6m, 8b, 3gt, 57750hp, 35.5kts, 328p; 57belt, 25deck, 25turrets; (2x2+2x1)-140/50, 1x1-76/40, 2x2-610TT, 48mines
Sendai	3	20	Sendai	1924		7100t, 163.0x14.2x4.9m, 12b, 4gt, 90000hp, 35.2kts, 450p; 64belt, 29deck; 7x1-140/50, 2x1-76/40, 4x2-610TT, 48mines, 1seaplane (E2N)
		21	Naka	1925		
		22	Jintsu	1925		

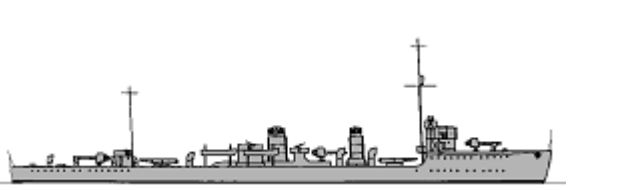
TORPEDO SHIPS

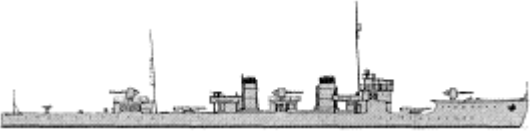
		1	Umikaze	1911		
--	--	---	---------	------	--	--



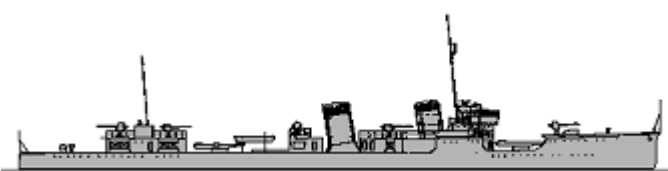

Umikaze	2	2	Yamakaze	1911		1150t, 98.5x8.5x2.7m, 8b, 3t, 20500hp, 33kts, 140p; 2x1-120/40, 5x1-76/40, 2x2-450TT(1), 3x1-450TT(2)
Sakura	2	3	Sakura	1912		830t, 83.6x7.3x2.2m, 5b, 3vte, 9500hp, 30kts, 92p; 1x1-120/40, 4x1-76/40, 2x2-450TT
		4	Tachibana	1912		
Urakaze	1	5	Urakaze	1915		1085t, 87.2x8.4x2.4m, 3b, 2t, 22000hp, 30kts, 120p; 1x1-120/40, 4x1-76/40, 2x2-533TT
Kaba	10	6	Kaba	1915		850t, 83.6x7.3x2.3m, 4b, 3vte, 9500hp, 30kts, 92p; 1x1-120/40, 4x1-76/40, 2x2-450TT
		7	Matsu	1915		
		8	Kashiwa	1915		
		9	Katsura	1915		
		10	Kaede	1915		
		11	Kiri	1915		
		12	Kusunoki	1915		
		13	Ume	1915		
		14	Sakaki	1915		
15	Sugi	1915				
Momo	4	16	Momo	1916		1080t, 85.6x7.7x2.3m, 4b, 2gt, 16000hp, 31.5kts, 110p; 3x1-120/40, 2x3-450TT
		17	Kashi	1917		
		18	Hinoki	1917		
		19	Yanagi	1917		
Amatsukaze	4	20	Amatsukaze	1917		1570t, 96.9x8.5x2.8m, 5b, 3t, 27000hp, 34kts, 128p; 4x1-120/40, 3x2-450TT
		21	Isokaze	1917		
		22	Tokitsukaze	1917		
		23	Hamakaze	1917		
Kawakaze	2	24	Kawakaze	1918		1580t, 103.6x8.8x2.8m, 4b, 2gt(24)-2t(25), 34000hp, 37.5kts, 128p; 3x1-120/45, 2x3-533TT
		25	Tanikaze	1919		
Enoki	6	26	Enoki	1918		1100t, 85.8x7.7x2.3m, 4b, 2gt, 17500hp, 31.5kts, 110p; 3x1-120/40, 2x3-450TT
		27	Nara	1918		
		28	Tsubaki	1918		
		29	Kuwa	1918		
		30	Keyaki	1918		
		31	Maki	1918		
		32	Momi	1919		

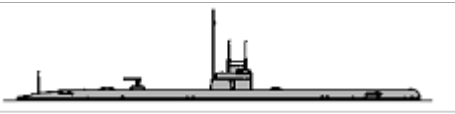
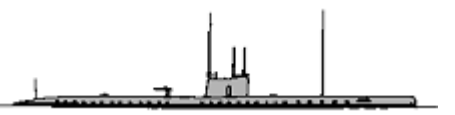
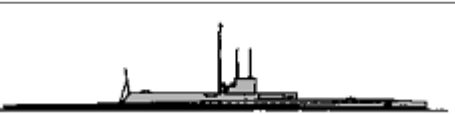
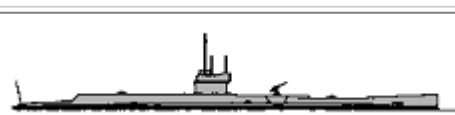

DD	Momi	20	33	Nashi	1919		1020t, 85.3x7.9x2.4m, 3b, 2gt, 21500hp, 36kts, 110p; 3x1-120/45, 2x2-533TT, 20mines, MS	
			34	Take	1919			
			35	Kaya	1920			
			36	Nire	1920			
			37	Kaki	1920			
			38	Kuri	1920			
			39	Tsuga	1920			
			40	Kiku	1920			
			41	Aoi	1920			
			42	Fuji	1921			
			43	Hagi	1921			
			44	Susuki	1921			
			45	Ashi	1921			
			46	Tsuta	1921			
			47	Hasu	1922			
			48	Hishi	1922			
			49	Yomogi	1922			
			50	Tade	1922			
			51	Sumire	1923			
				Minekaze	15			52
	53	Sawakaze	1920					
	54	Okikaze	1920					
	55	Hakaze	1920					
	56	Yakaze	1920					
	57	Shimakaze	1920					
	58	Nadakaze	1921					
	59	Akikaze	1921					
	60	Shiokaze	1921					
	61	Yukaze	1921					
	62	Hokaze	1921					
	63	Tachikaze	1921					
	64	Nokaze	1922					
	65	Namikaze	1922					
	66	Numakaze	1922					
		Kamikaze	9	67	Kamikaze	1922		1720t, 102.6x9.1x2.9m, 4b, 2gt, 38500hp, 37.2kts, 148p; 4x1-120/45, 3x2-533TT, 20mines, sweeps
	68			Asakaze	1923			
	69			Harukaze	1923			
	70			Matsukaze	1924			
	71			Hatakaze	1924			
	72			Oite	1925			
	73			Hayate	1925			

		74	Asanagi	1925		
		75	Yunagi	1925		
Wakatake	8	76	Wakatake	1922		1100t, 85.3x7.9x2.5m, 3b, 2gt, 21500hp, 35.5kts, 110p; 3x1-120/45, 2x2-533TT, 20mines, MS
		77	Kuretake	1922		
		78	Sanae	1923		
		79	Asagao	1923		
		80	Fuyo	1923		
		81	Karukaya	1923		
		82	Sawarabi	1924		
		83	Yugao	1924		
Mutsuki	12	84	Kisaragi	1925		1772t, 102.7x9.2x3.0m, 4b, 2gt, 38500hp, 37.2kts, 150p; 4x1-120/45, 2x3-610TT, 2DCT, 16mines, MS
		85	Satsuki	1925		
		86	Mutsuki	1926		
		87	Yayoi	1926		
		88	Uzuki	1926		
		89	Fumizuki	1926		
		90	Kikuzuki	1926		
		91	Minazuki	1927		
		92	Nagatsuki	1927		
		93	Mikazuki	1927		
		94	Mochizuki	1927		
		95	Yuzuki	1927		
Fubuki	11	96	Fubuki	1928		2097t, 118.4x10.4x3.2m, 4b, 2gt, 50000hp, 38kts, 197p; 3x2-127/50, 3x3-610TT, 2DCT, 18mines
		97	Shinonome	1928		
		98	Usugumo	1928		
		99	Shirakumo	1928		
		100	Isonami	1928		
		101	Shirayuki	1928		
		102	Murakumo	1928		
		103	Hatsuyuki	1929		
		104	Miyuki	1929		
		105	Uranami	1929		
		106	Shikinami	1929		

## SUBMARINES

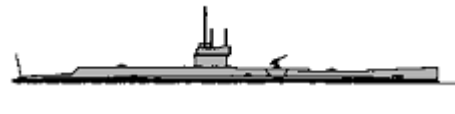
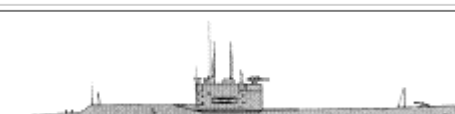
K1	2	1	RO11	1919		735/1030t, 69.2x6.4x3.4m, 2d/em, 2600/1200hp, 18/9kts, 44p, 30m; 1x1-76/23, 6-450TT
		2	RO12	1919		
F1	2	3	RO1	1920		689/1047t, 65.6x6.1x4.2m, 2d/em, 2800/1200hp, 13/8kts, 43p, 40m; 1x1-76/23, 5-450TT
		4	RO2	1920		

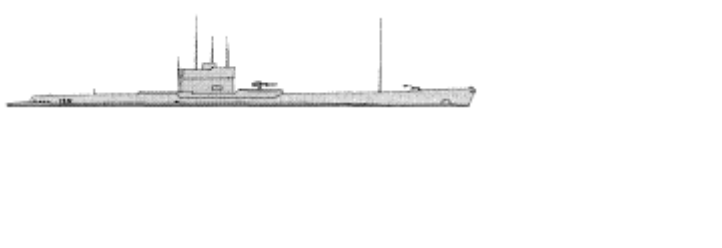
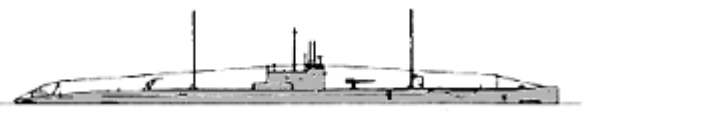
						
F2	3	5	RO3	1922		689/1047t, 65.6x6.1x4.1m, 2d/em, 2600/1200hp, 14/8kts, 43p, 40m; 1x1-76/23, 5-450TT
		6	RO4	1922		
		7	RO5	1922		
K2	3	8	RO13	1920		755/1050t, 70.1x6.1x3.7m, 2d/em, 2600/1200hp, 17/9kts, 45p, 45m; 1x1-76/23, 6-450TT
		9	RO14	1921		
		10	RO15	1921		
L1	2	11	RO51	1920		893/1195t, 70.6x7.2x3.9m, 2d/em, 2400/1600hp, 17/8kts, 48p, 60m; 1x1-76/23, 6-450TT
		12	RO52	1920		
K3	10	13	RO16	1922		755/1050t, 70.1x6.1x3.7m, 2d/em, 2600/1200hp, 17/9kts, 45p, 45m; 1x1-76/23, 6-450TT
		14	RO17	1921		
		15	RO18	1921		
		16	RO19	1922		
		17	RO20	1922		
		18	RO21	1922		
		19	RO22	1922		
		20	RO23	1923		
		21	RO24	1920		
		22	RO25	1921		
L2	4	23	RO53	1921		893/1195t, 70.6x7.1x3.9m, 2d/em, 2400/1600hp, 17/8kts, 48p, 60m; 1x1-76/23, 4-450TT
		24	RO54	1921		
		25	RO55	1921		
		26	RO56	1922		
L3	3	27	RO57	1922		897/1195t, 76.2x7.2x4.0m, 2d/em, 2400/1600hp, 17/8kts, 48p, 60m; 1x1-76/23, 4-533TT
		28	RO58	1922		
		29	RO59	1923		
K4	3	30	RO26	1923		770/1080t, 74.2x6.1x3.7m, 2d/em, 2600/1200hp, 17/9kts, 45p, 45m; 1x1-76/23, 4-533TT
		31	RO27	1924		
		32	RO28	1923		
SS KT	4	33	RO29	1923		665/1030t, 74.2x6.1x3.7m, 2d/em, 1200/1200hp, 13/8kts, 43p, 75m; 1x1-120/45, 4-533TT
		34	RO30	1924		
		35	RO31	1927		
		36	RO32	1924		
L4	9	37	RO60	1923		996/1322t, 76.2x7.4x3.8m, 2d/em, 2400/1600hp, 16.5/9kts, 47p, 60m; 1x1-76/40, 6-533TT
		38	RO61	1924		
		39	RO62	1924		
		40	RO63	1924		
		41	RO64	1925		

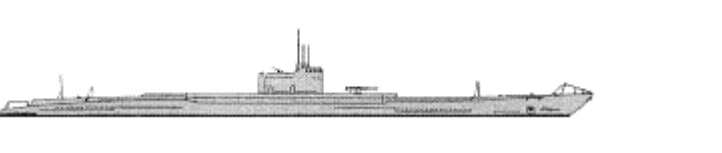
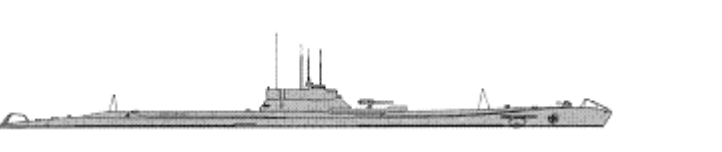
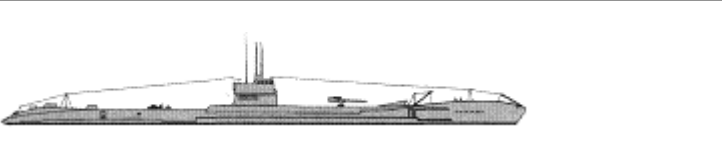
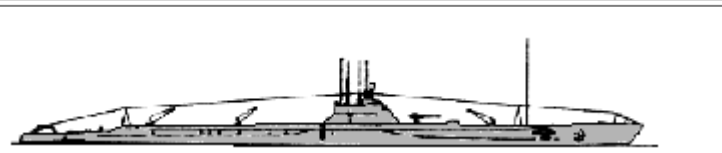
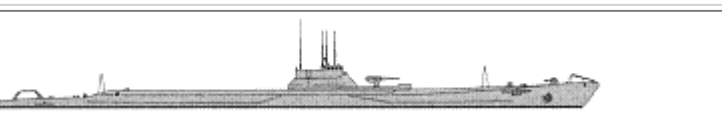
						
		42	RO65	1926		
		43	RO66	1927		
		44	RO67	1926		
		45	RO68	1925		
KD1	1	46	I51	1924		1500/2430t, 91.4x8.8x4.6m, 4d/em, 5200/2000hp, 20/10kts, 60p, 60m; 1x1-120/45, 1x1-76/40, 8-533TT
KD2	1	47	I52	1925		1500/2500t, 100.9x7.6x5.1m, 2d/em, 6800/2000hp, 22/10kts, 60p, 60m; 1x1-120/45, 1x1-76/40, 8-533TT
J1	4	48	I1	1926		2135/2791t, 97.5x9.2x5.0m, 2d/em, 6000/2600hp, 18/8kts, 92p, 80m; 2x1-140/40, 6-533TT
		49	I2	1926		
		50	I3	1926		
		51	I4	1929		
KD3a	4	52	I53	1927		1800/2300t, 100.6x8.0x4.8m, 2d/em, 6800/1800hp, 20/8kts, 64p, 60m; 1x1-120/45, 8-533TT
		53	I54	1927		
		54	I55	1927		
		55	I58	1928		
KRS	4	56	I21	1927		1383/1768t, 85.2x7.5x4.4m, 2d/em, 2400/1100hp, 14.5/7kts, 51p, 75m; 1x1-140/40, 4-533TT, 42mines
		57	I22	1927		
		58	I23	1928		
		59	I24	1928		
KD3b	4	60	I56	1929		1800/2300t, 101.0x7.9x4.9m, 2d/em, 6800/1800hp, 20/8kts, 79p, 60m; 1x1-120/45, 8-533TT
		61	I57	1929		
		62	I60	1929		
		63	I63	1928		
KD4	1	64	I61	1929		1720/2300t, 97.7x7.8x4.8m, 2d/em, 6000/1800hp, 20/8.5kts, 58p, 60m; 1x1-120/45, 6-533TT

OTHER FIGHTING SHIPS

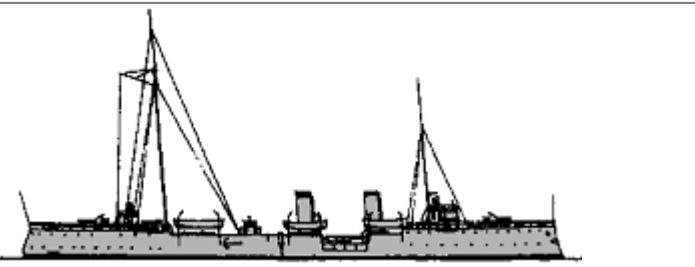
						
Chihaya	1	1	Chihaya (TS)	1901		1464t, 87.7x9.6x2.8m, 4b,2vte, 6000hp, 21kts, 125p; 2x1-120/40, 4x1-76/40, 2x1-450TT

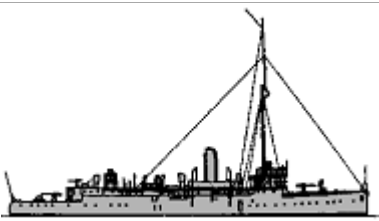
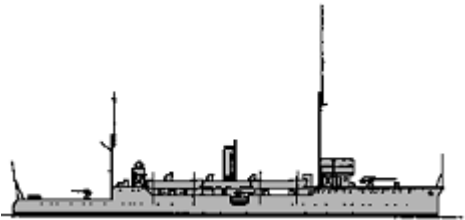
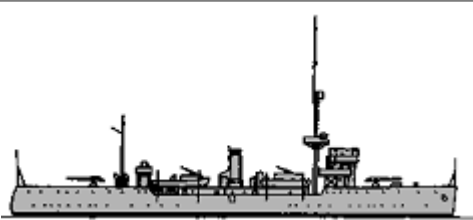
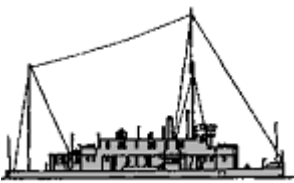
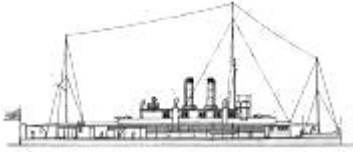
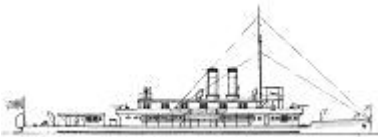
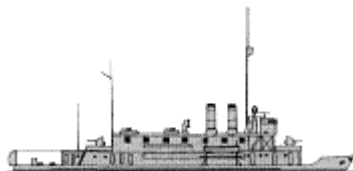
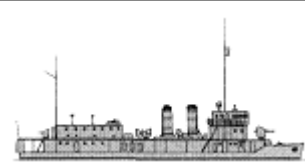

PG	Uji	1	2	Uji	1903		620t, 57.8x8.4x2.1m, 2b, 2vte, 1000hp, 13kts, 88p; 4x1-76/40
	Saga	1	3	Saga	1912		885t, 69.0x9.0x2.2m, 2b, 2vte, 1600hp, 15kts, 98p; 1x1-120/45, 3x1-76/40
	Ataka	1	4	Ataka	1923		1133t, 71.7x9.0x2.3m, 2b, 2vte, 1700hp, 16kts, 118p; 2x1-120/45, 2x1-76/40
PR	Sumida	1	1	Sumida	1906		126t, 44.2x7.2x0.6m, 2b, 3vte, 550hp, 13kts, 40p; 2x1-47/40
	Fushimi	1	2	Fushimi	1906		180t, 48.7x7.4x0.7m, 2b, 3vte, 900hp, 14kts, 45p; 2x1-57/40
	Toba	1	3	Toba	1911		291t, 55.9x8.2x0.8m, 2b, 3vte, 1400hp, 15kts, 59p; 2x1-76/23
	Seta	4	4	Seta	1923		400t, 56.1x8.2x1.0m, 2b, 2vce, 2100hp, 16kts, 62p; 2x1-76/40
			5	Kataka	1923		
6			Hira	1923			
7			Hozu	1923			
Atami	1	8	Atami	1929		249t, 46.3x6.3x0.9m, 2b, 2vce, 1300hp, 16.7kts, 77p; 1x1-76/23, 1x1-13.2/76	

## COASTAL FORCES

PT	CMB-55	4	1 - 4	No615, 1149 and 2 others	1920		14t, 16.8x3.4x1.0m, 2pe, 1000hp, 40kts, 5p; 2-450TT, 1DCR
----	--------	---	-------	--------------------------	------	---	---

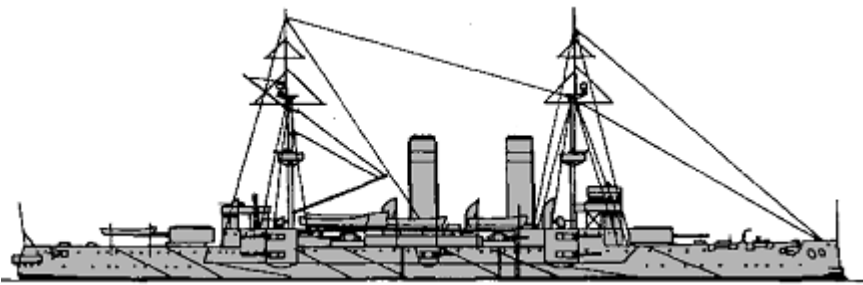
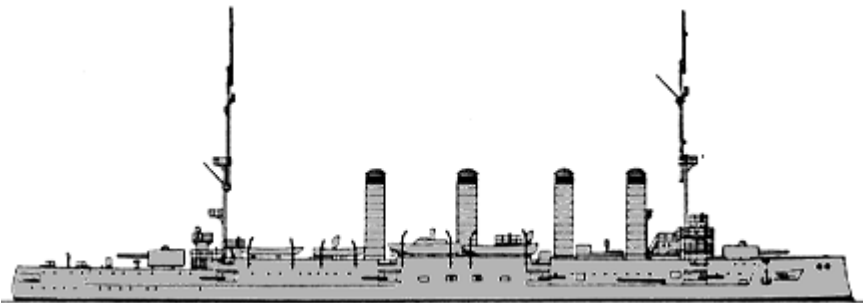

MINE WARFARE

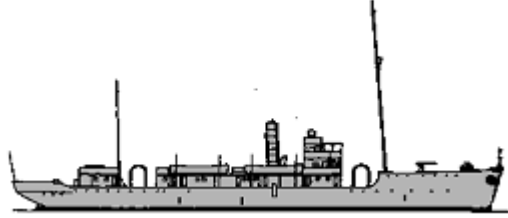
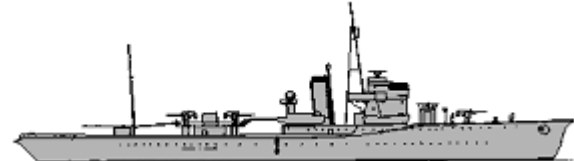
ML	Tokiwa	1	1	Tokiwa	1899		10500t, 134.7x20.5x7.4m, 16b, 2vte, 18000hp, 21.5kts, 726p; HN 178belt, 76deck, 152turrets, 356CT; 1x2-203/45, 8x1-152/40, 3x1-76/40, 300mines
	Aso	1	2	Aso	1903		7800t, 137.0x17.5x6.5m, 26b, 2vte, 16500hp, 21kts, 593p; H 200belt, 50decl, 60casemates, 160CT; 2x1-152/50, 8x1-152/45, 16x1-76/40, 420mines
	Natsushima	13	3	Natsushima	1912		435t, 45.7x7.6x2.3m, 1b, 1vte, 600hp, 12.8kts, 40p; 2x1-76/40, 60mines, MS
			4	Sokuten	1913		
			5	Toshima	1915		
			6	Kuroshima	1915		
7			Ashizaki	1916			
8			Katoku	1916			
9			Kurokami	1917			
10			Katashima	1917			
11			Ento	1917			
12			Enoshima	1919			
13	Kurosaki	1921					
14	Ninoshima	1920					
15	Washizaki	1921					
Katsuriki	1	16	Katsuriki	1917		2000t, 73.1x11.9x4.3m, 2b, 2vte, 1800hp, 13kts, 3x1-76/40, 150mines	
Shirataka	1	17	Shirataka	1929		1692t, 84.0x11.6x3.0m, 2b, 2vte, 2000hp, 16kts, 3x1-120/45, 100mines	



	Itsukushima	1	18	Itsukushima	1929		2408t, 107.5x11.8x3.2m, 3d, 3000hp, 17kts, 235p; 3x1-140/50, 2x1-76/40, 300mines, 2DCT
	Kamome	2	19	Kamome	1929		557t, 68.8x7.2x2.1m, 2b, 2vte, 2500hp, 19kts, 56p; 1x1-76/40, 1x1-13.2/76, 120mines
			20	Tsubame	1929		
MS	W1	4	1	W1	1923		702t, 76.3x8.0x2.3m, 3b, 2vte, 4000hp, 20kts, 92p; 2x1-120/45, 1x1-76/40, MS
			2	W2	1923		
			3	W3	1923		
			4	W4	1925		
	W5	2	5	W5	1929		717t, 77.0x8.2x2.2m, 3b, 2vte, 4000hp, 21kts, 87p; 2x1-120/45, 1x1-76/40, 1x1-13.2/76, MS
			6	W6	1929		
	Asakaze	6	7	W7	1909		450t, 72.0x6.6x1.8m, 4b, 2vte, 6000hp, 29kts, 70p; 2x1-120/40, 2x1-76/40, MS
			8	W8	1908		
			9	W9	1909		
			10	W10	1907		
			11	W11	1907		
			12	W12	1907		

NAVAL AVIATION *(approximately, maximal number of delivered planes signed)*

Deck planes	F: 50 A1N1;TB: 196 B1M1, 116 B1M2, 128 B1M3 (delivery till 1932);R: 159 C1M1, C1M2 and C1M3
Seaplanes	R: 10 W.33, 90 E1Y1, 128 E1Y2 (delivery till 1931), 32 HD.25, 77 E2N1 (delivery till 1930), 12 E3A1 (delivery till 1932)

[home](#)[World navies yesterday](#)[1930](#)

## Latvia 01 January 1930

### SUBMARINES

SS	Ronis	2	1	Ronis	1927		390/514t, 55.0x4.8x3.6m, 2d/em, 1300/700hp, 14/9kts, 27p, 50m; 1x1-75/35, (2+2x2)-450TT
			2	Spidola	1927		

### ESCORTS

PC	Virsaitis	1	1	Virsaitis	1917		539t, 59.3x7.4x2.2m, 2b,2vte, 1850hp, 16kts, 51p; 2x1-88/45, 30m, MS
----	-----------	---	---	-----------	------	---	--

### MINE WARFARE SHIPS

MS	Viesturs	2	1	Viesturs	1926		310t, 48.9x6.5x1.5m, 2b,2vte, 750hp, 14kts, 39p; 1x1-75/35, 30m, MS
			2	Imanta	1926		

© Ivan Gogin, 2011-15

[home](#)

[World navies yesterday](#)

[1930](#)

## Lithuania 01 January 1930

### ESCORTS

PC	Prezidentas Smetona	1	1	Prezidentas Smetona	1917		535t, 59.3x7.3x2.2m, 2b,2vte, 1750hp, 16kts, 70p; 2x1-105/45, 30m, MS
----	---------------------	---	---	---------------------	------	--	---

© Ivan Gogin, 2011-15

[home](#)

[World navies yesterday](#)

[1930](#)

## Mexico 01 January 1930

### CAPTAL SHIPS

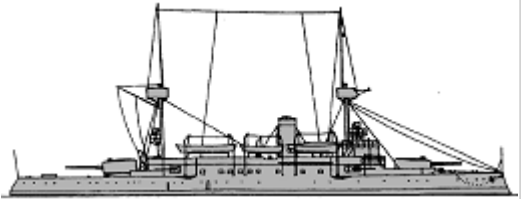
BC	Anahuac	1	1	Anahuac	1900		3162t, 81.5x14.4x4.2m, 8b,2vte, 3400hp, 15kts, 200p; Harvey steel; 350belt, 45deck, 220turrets, 125CT; 2x1-234/45, 4x1-120/50, 6x1-57/40, 2-450TT
----	---------	---	---	---------	------	--	---

### CRUISERS

CLP	Progreso	1	1	Progreso	1907		1700t, 70.1x10.3x3.0m, 1vte, 1400hp, 13kts, 140p; 4x1-57/40, troops
-----	----------	---	---	----------	------	--	---

### ESCORTS

TL	Salinas	4	1	Salinas	1917	No picture	486t, 40.5x7.1x4.1m, 1b,1vte, 557hp, 7kts, 26p; 1x1-57/40(2,3), 2x1-40/39(2,3), 1x1-25/60(1,4), 1x1-13.2(1,4)
			2	Mazatlan	1917		
			3	Tampico	1917		
			4	Vera Cruz	1917		

### OTHER FIGHTING SHIPS

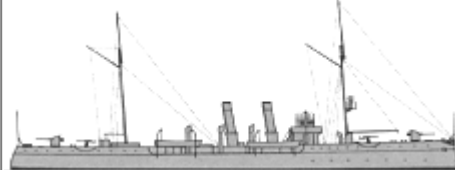
PG	Nicholas Bravo	1	1	Nicholas Bravo	1904		1493t, 73.8x10.4x3.0m, 2vte, 2565hp, 17kts, 116p; 2x1-102/40, 6x1-57/40, 1-356TT
----	----------------	---	---	----------------	------	--	--

	Agua Prieta	1	2	Agua Prieta	1893		1318t, 62.2x9.8x3.7m, 2b,2vte, 1900hp, 15.5kts, 157p; 8x1-102/40, 2x1-57/40
--	-------------	---	---	-------------	------	---	---

© Ivan Gogin, 2011-15

[home](#)[World navies yesterday](#)[1930](#)

# NETHERLANDS 01 January 1930



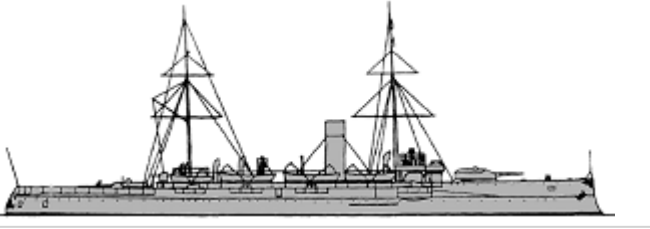
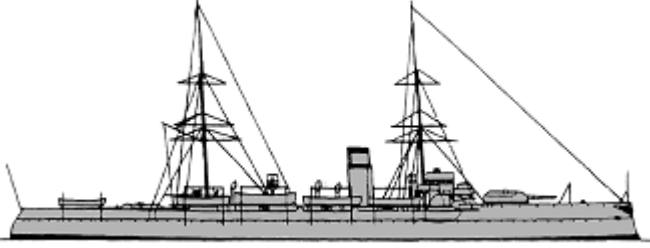
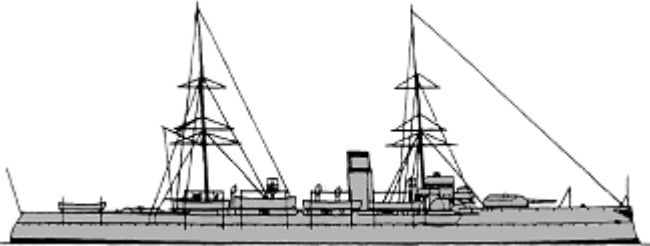
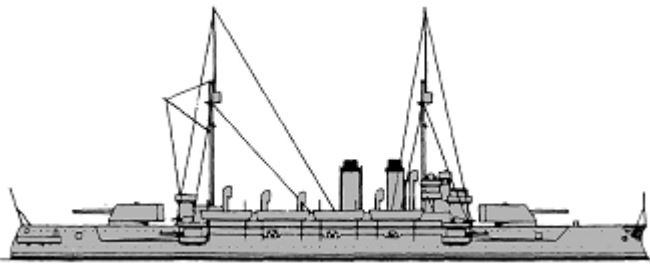

## CAPITAL SHIPS

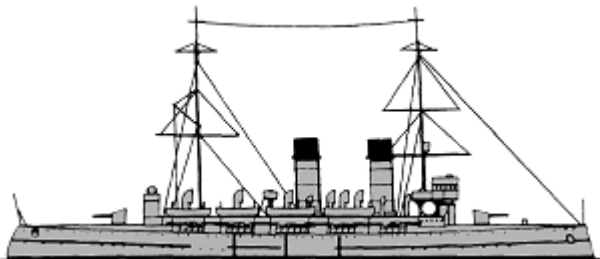
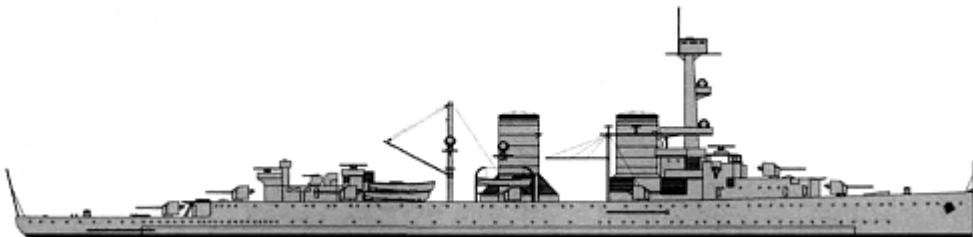
						5084t, 96.6x15.2x6.8m, 6b,2vte, 6500hp, 16.5kts, 340p; 152belt, 51deck, 102turrets, 246CT; 1x1-240/40, 4x1-150/40, 4x1-75/55, 3-450TT, 2seaplanes (Fairey IIIIF)
						5295t, 100.8x15.2x5.7m, 8b,2vte, 6400hp, 16.5kts, 340p; 152belt, 51deck, 102turrets, 194CT; 2x1-240/40, 4x1-150/40, 8x1-75/55, 3-450TT
BC						4920t, 98.0x15.2x5.7m, 8b,2vte, 6400hp, 16.5kts, 340p; 152belt, 51deck, 102turrets, 194CT; 2x1-240/40, 4x1-150/40, 6x1-75/55, 2-450TT
						6510t, 103.5x17.1x6.2m, 8b,2vte, 8000hp, 16kts, 448p; 150belt, 50deck, 250turrets, 200CT; 2x1-283/43, 4x1-150/40, 10x1-75/55

## CRUISERS



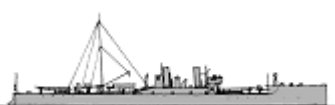
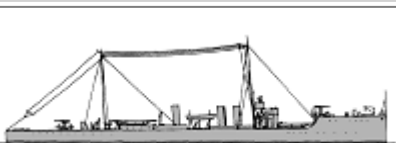







CL	Holland	1	1	Gelderland	1900		3970t, 94.7x14.8x5.4m, 10b,2vte, 10000hp, 20kts, 371p; Harvey; 57deck, 152shields, 102CT; 8x1-120/40, 4x1-75/55
	Java	2	3	Sumatra	1925 1926		8208t, 155.3x16.0x5.5m, 8b,3gt, 65000(2)-82000(3)hp, 30kts, 480p; 75belt, 25deck, 100turrets, 125CT; 10x1-150/50, 4x1-75/55, 36m, 2seaplanes (C.VIIW)

### TORPEDO SHIPS

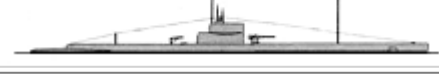
DD	De Ruyter	4	1	De Ruyter	1928		1640t, 98.2x9.5x3.0m, 3b,2gt, 31000hp, 36kts, 129p; 4x1-120/50, 2x1-75/55, 4x1-12.7, 2x3-533TT, 4DCT, 32m, 1seaplane (C.VIIW)
			2	Evertsen	1928		
			3	Kortenaer	1928		
			4	Piet Hein	1928		
	Van Galen	1	5	Van Galen	1929		1650t, 98.2x9.5x3.0m, 3b,2gt, 31000hp, 36kts, 120p; 4x1-120/50, 1x1-75/55, 4x1-40/39, 4x1-12.7, 2x3-533TT, 4DCT, 1seaplane (C.VIIW)
TB	G13	3	1	G13	1914		230t, 49.5ppx5.3x1.5m, 2b,2vte, 2600hp, 25kts, 27p; 2x1-75/30, 3x1-450TT
			2	G15	1914		
			3	G16	1914		
	Z5	4	4	Z5	1917		310t, 58.5ppx6.1x1.7m, 3b,2vte, 5500hp, 27kts, 46p; 2x1-75/30, 2x1-12.7, (1x2+2x1)-450TT
			5	Z6	1917		
			6	Z7	1916		
			7	Z8	1916		
	Z1	4	8	Z1	1919		322t, 62.6x6.2x1.9m, 3b,2t, 5500hp, 27kts, 46p; 2x1-75/30, 2x1-12.7, (1x2+2x1)-450TT
			9	Z2	1921		
			10	Z3	1920		
			11	Z4	1920		

### SUBMARINES

O2	4	1	O2	1911	130/150t, 32.1x3.3x2.7m, 1d/em, 350/200hp, 11/8.6kts, 10p, 25m; 2-450TT
		2	O3	1913	

SS		3	O4	1914			
		4	O5	1914			
	O6	1	5	O6	1916		189/229t, 35.7x4.1x3.1m, 1d/em, 375/185hp, 12/8.5kts, 15p, 40m; 3-450TT
	O7	1	6	O7	1916		176/206t, 34.7x3.9x2.9m, 1d/em, 350/185hp, 11.5/8.5kts, 15p, 40m; 3-450TT
	M1	1	7	M1	1915		168/183t, 34.0x3.2x3.0m, 1d/em, 90/175hp, 6.2/5.2kts, 14p, 50m; 12m
	O8	1	8	O8	1915		364/434t, 45.8x4.7x3.8m, 2d/em, 480/620hp, 13/11kts, 22p, 50m; 1x1-37/45, 4-450TT
	K III	2	9	K III	1920		583/721t, 64.4x5.6x3.6m, 2d/em, 1800(10)-1200(11)/630hp, 16.5(10)-15(11)/8.5kts, 29p, 40m; 1x1-75/55, 1x1-12.7, (4+1x2)-450TT
			10	K IV	1921		
	K V	3	11	K V	1920		569/649t, 57.3x5.6x3.8m, 2d/em, 1200/400hp, 13.5/8kts, 31p, 40m; 1x1-75/55, 1x1-12.7, (4+1x2)-450TT
			12	K VI	1921		
			13	K VII	1922		
	K II	1	14	K II	1922		569/649t, 57.3x5.3x3.8m, 2d/em, 1800/500hp, 15.5/8.5kts, 29p, 40m; 1x1-75/55, 1x1-12.7, (4+1x2)-450TT
	K VIII	3	15	K VIII	1922		583/810t, 64.4x5.6x3.6m, 2d/em, 1800(16)-1550(17,18)/400hp, 16(16)-15(17,18)/8kts, 31p, 50m; 1x1-88/45, 1x1-12.7, 4-450TT
			16	K IX	1923		
			17	K X	1923		
	K XI	3	18	K XI	1925		688/828t, 66.7x6.2x3.8m, 2d/em, 2400/654hp, 17/8kts, 31p, 60m; 1x1-88/45, 1x1-12.7, 2-533TT, 4-450TT
			19	K XII	1925		
			20	K XIII	1926		
	O9	3	21	O9	1926		526/656t, 54.7x5.7x3.5m, 2d/em, 900/500hp, 12/8kts, 29p, 60m; 1x1-88/45, 1x1-12.7, 2-533TT, 3-450TT
			22	O10	1926		
			23	O11	1926		



## ESCORTS

PC	Albatros	1	1	Albatros	1912	No picture	892t, 50.0ppx9.4x3.3m, 1vte, 1140hp, 12kts, 47p; 2x1-37/45
	Orion	1	2	Orion	1912	No picture	1062t, 55.9ppx9.0x3.7m, 1vte, 1380hp, 14kts, 71p; 2x1-75/55
	Aldebaran	1	3	Aldebaran	1913	No picture	892t, 53.3ppx8.2x3.5m, 1vte, 800hp, 12kts, 45p; 2x1-37/45
	Bellatrix	3	4	Bellatrix	1914	No picture	773t, 53.3ppx9.0x3.0m, 1vte, 800hp, 12kts, 45p; 1x1-75/55(4), 2x1-37/45(5,6)
			5	Canopus	1915		
			6	Deneb	1915		
	Eridanus	1	7	Eridanus	1918	No picture	996t, 56.5ppx9.0x3.2m, 1vte, 800hp, 12kts, 44p; 1x1-75/55
	Gemma	1	8	Gemma	1918	No picture	845t, 53.3ppx9.0x3.2m, 1vte, 800hp, 12kts, 44p; 1x1-75/55
	Sirius	2	9	Sirius	1922	No picture	1015t, 55.6ppx9.5x3.3m, 1vte, 900hp, 12.5kts, 50p; 1x1-75/55
			10	Wega	1922		

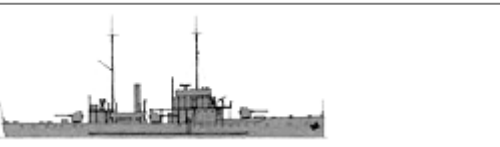
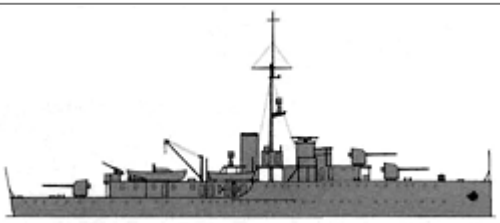
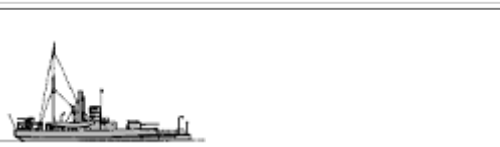

	Fomalhaut	1	11	Fomalhaut	1923	No picture	1001t, 56.9ppx9.5x3.4m, 1vte, 855hp, 12.5kts, 55p; 2x1-37/45
	Merel	1	12	Merel	1928	No picture	592t, 46.4ppx8.4x2.8m, 2b,1vte, 525hp, 12kts, 40p; 1x1-75/55
	Arend	2	13	Arend	1929	No picture	1011t, 71.9x9.0x2.8m, 2b,2vte, 3350hp, 18kts, 61p; 2x1-75/55, 1seaplane (C.VIIW)
			14	Valk	1929		

## OTHER FIGHTING SHIPS



	Koetei	1	1	Koetei	1898		788t, 53.7x9.4x3.7m, 2vte, 1380hp, 13.7kts, 97p; 2x1-105/35, 4x1-37/23, 2x5-37/20
PG	Brinio	3	2	Brinio	1914		634(2)-573(3)-581(4)t, 52.7x8.5x2.8m, 2d, 1200(2)-1500(3,4)hp, 14kts, 52p; 55belt, 17deck, 50shields, 50CT; 4x1-105/50, 2x1-12.7
			3	Friso	1915		
			4	Gruno	1915		
	Flores	2	5	Flores	1926		1793t, 76.4x11.5x3.6m, 4b,2vte, 2000hp, 15kts, 132p; 50slopes, 25deck, 80shields, 50CT; 3x1-150/50, 1x1-75/55, 2x2-12.7, 1seaplane (C.VIIW)
6			Soemba	1926			
	K1	1	1	K2 Christiaan Cornelis	1905	No picture	47t, 30.0x3.6x1.7m, 1b,1vte, 560hp, 18.7kts, 12p; 1x1-37/23
PR	Wodan	4	3	Braga	1879		280t, 27.8x8.2x2.3m, 2b,1vce, 171hp, 8.3kts, 34p; 1x1-120/40(3,6), 1x1-75/55(4), 2x1-37/23, 1x5-37/20
			4	Freyr	1877		
			5	Tyr	1878		
			6	Hefring (TS)	1880		
DV	Fret	1	1	Panter	1914		510t, 70.4x6.6x2.0m, 4b,2t, 8500hp, 30kts, 83p; 4x1-75/40

## COASTAL FORCES

PT	TM I	4	1 - 4	TM I - IV	1927 - 1928		11t, 16.8x3.4x0.9m, 2pe, 375hp, 37kts, 5p; 2-450TT, 1DCR
----	------	---	-------	-----------	-------------	--	--

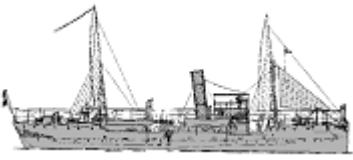
## MINE WARFARE SHIPS

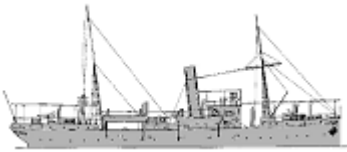
	Serdang	1	1	Serdang	1897		820t, 53.9x9.4x3.7m, 2vte, 1300hp, 12.9kts, 97p; 1x1-105/35, 4x1-37/23, 2x5-37/20, ~50m
			2	Siboga	1898		

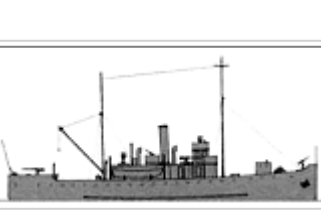
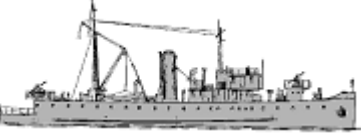
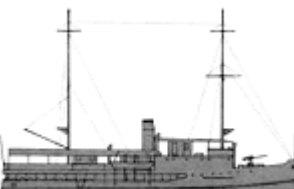
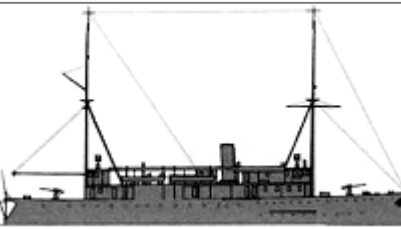
ML	Koetei	2	3	Assahan	1900		788t, 53.7x9.4x3.7m, 2vte, 1380hp, 13.7kts, 97p; 1x1-105/35, 4x1-37/23, 2x5-37/20, ~50m
	Hydra	1	4	Havik	1874		218t, 25.9x8.2x2.3m, 2b,1vce, 146hp, 8kts, 34p; 2x1-37/23, 1x5-37/20, ~20m
	Wodan	5	5	Balder	1879		280t, 27.8x8.2x2.3m, 2b,1vce, 171hp, 8.3kts, 34p; 1x1-150/40(6), 2x1-37/23, 1x5-37/20, ~20m
			6	Thor	1877		
			7	Vidar	1879		
			8	Hadda	1880		
	Hydra	2	9	Bulgia	1884		670t, 49.7x9.0x2.8m, 2b,2vte, 900hp, 11kts, 59p; 3x1-75/55, 2x1-12.7, 70m
			10	Hydra	1912		
Van Meerlant	2	11	Medusa	1911		748t, 54.8ppx8.7x3.2m, 2b,2vte, 1000hp, 13kts, 60p; 3x1-75/55, 2x1-12.7, 60m	
		12	Van Meerlant	1922			
Pro Patria	1	13	Douwe Aukes	1922		612t, 47.0ppx8.6x2.3m, 2b,1vte, 650hp, 10kts, 61p; 1x1-75/40, 2x1-12.7, 60m	
		14	Pro Patria	1923			
Krakatau	1	15	Krakatau	1924		1160t, 65.0ppx10.0x3.2m, 2b,1vte, 2500hp, 15.5kts, 105p; 2x1-75/40, 4x1-12.7, 150m	
AML	-	1	1	Hercules	1910		234t; 20m
MS	Nr.1	4	1	M1	1918	No picture	238(1)-205(2)-230(3,4)t, 30.5(1)-29.7(2)-29.8(3,4)x 7.0(1)-6.7(2)-6.4(3,4)x 2.8(1)-3.1(2)-2.5(3,4)m, 1b,1vte, 500(1,2)-450(3,4)hp, 9.5(1)-10(2-4)kts, 16p; 1x1-12.7, MS
			2	M2	1918		
			3	M3	1918		
			4	M4	1918		

## NAVAL AVIATION (approximately, maximal number of delivered planes signed)

Seaplanes

R: 41 WA, 30 C.VIIW (delivery till 1932)

© Ivan Gogin, 2011-14

[home](#)

[World navies yesterday](#)

[1930](#)

## NEW ZEALAND 01 January 1930

### CRUISERS

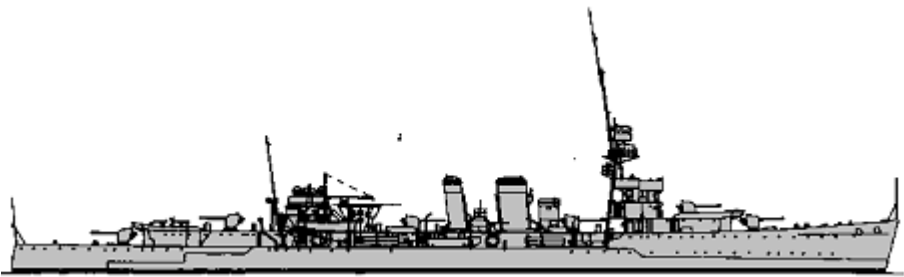
		1	Dunedin	1919		5870t, 143.6x13.9x5.0m, 6b, 2gt, 40000hp, 29kts, 450p; 76belt, 25shields, 25deck, 76CT; 6x1-152/45, 3x1-102/45, 2x1-40/39, 4x3-533TT
CL	Delhi	2	Diomedé	1922		

© Ivan Gogin, 2010-15



[home](#)[World navies yesterday](#)[1930](#)



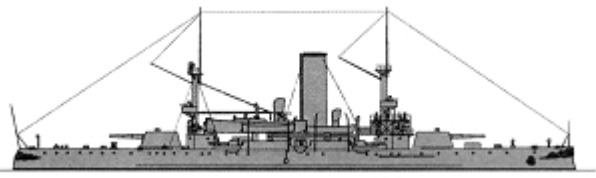
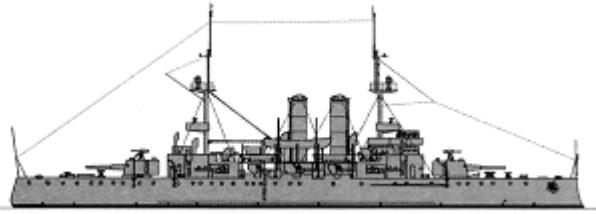



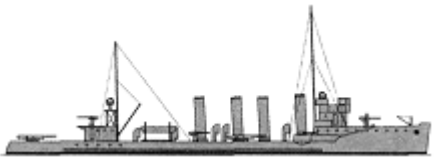

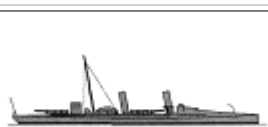
# NORWAY 01 January 1930

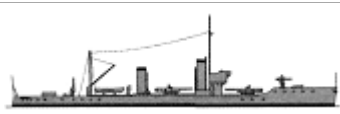
## CAPITAL SHIPS



BC	Harald Haarfagre	1	Harald Haarfagre	1898		3858t, 92.7x14.8x5.4m, 3b, 2vte, 4000hp, 16.9kts, 245p; h: 178belt, n: 51deck, 203turrets, 152CT; 2x1-209/44, 6x1-120/44, 6x1-76/40, 2x1-47/46, 6x1-37/45, 2-450TT
		2	Tordenskjold	1898		
	Norge	3	Norge	1901		4166t, 94.6x15.4x5.4m, 6b, 2vte, 4500hp, 16.5kts, 266p; 152belt, n: 51deck, 203turrets, 152CT; 2x1-209/44, 6x1-149/46, 8x1-76/40, 6x1-47/46, 2-450TT
		4	Eidsvold	1901		

## TORPEDO SHIPS

DD	Draug	3	1	Draug	1907		578(1, 2)-597(3)t, 69.2x7.3x2.9m, 4b, 2vte(1, 2)-2t(3), 7500(1, 2)-8000(3)hp, 26.5(1)-27(2)-27.4(3)kts, 76p; 6x1-76/40, 3x1-450TT
			2	Troll	1912		
			3	Garm	1914		
	Hval	1	1	Hval	1896		102t, 39.9x4.8x2.2m, 2b, 1vte, 1100hp, 21kts, 23p; 2x1-37/45, 2x1-450TT
	Storm	3	2	Storm	1898		107t, 39.9x4.8x2.2m, 2b, 1vte, 1100hp, 21kts, 23p; 2x1-37/45, 2x1-450TT
			3	Brand	1898		
			4	Trods	1898		
	Laks	4	5	Laks	1900		107t, 38.5x4.8x2.2m, 2b, 1vte, 1150hp, 21kts, 23p; 2x1-37/45, 2x1-450TT
			6	Sild	1900		
			7	Sæl	1901		
			8	Skrei	1901		

TB	Trygg	3	9	Trygg	1920		256t, 53.0x5.5x2.0m, 2b, 2vte, 3500hp, 25(9, 10)-24(11)kts, 33p; 2x1-76/28, 2x2-450TT, mines	
			10	Snøgg	1921			
			11	Stegg	1923			
		Lyn	2	12, 13	Lyn, Blink	1896		64t, 34.5x3.8x1.8m, 2b, 1vte, 650hp, 19kts, 21p; 1x1-37/45, (1+1x1)-450TT
		Djerv	2	14	Kvikk	1898		66t, 34.5x3.8x1.7m, 2b, 1vte, 650hp, 19kts, 21p; 2x1-37/45, (1+1x1)-450TT
		Hvass	2	15, 16	Hvass, Kjæk	1901		74t, 34.1x4.4x1.6m, 2b, 2vte, 650hp, 19kts, 16p; 2x1-37/45, (1+1x1)-450TT
		Hauk	2	17, 18	Hauk, Falk	1904		73t, 34.9x4.4x1.6m, 2b, 2vte, 750hp, 20kts, 16p; 2x1-37/45, (1+1x1)-450TT
		Ørn	2	19, 20	Ørn, Ravn	1905		73t, 34.5x4.4x1.6m, 2b, 1vte, 850hp, 23kts, 16p; 2x1-37/45, (1+1x1)-450TT
		Grib	3	21-22	Grib, Jo, Lom	1906		74t, 36.2x4.5x1.9m, 2b, 1vte, 1000hp, 23kts, 16p; 2x1-37/45, (1+1x1)-450TT
	Teist	3	23	Teist	1908		103(1, 2)-108(3)t, 41.1x4.7x2.3(1, 2)-2.4(3), 2b, 1vte, 1700hp, 25kts, 21p; 1x1-76/28(3), 2x1-47/46(1, 2), (1+2x1)-450TT(1, 2), (1+1x1)-450TT(3)	
			24	Skarv	1908			
			25	Kjell	1913			

## SUBMARINES

SS	A1	1	1	A1	1909	No picture	206/259t, 39.3x3.7x3.0m, 2d/em, 440/250hp, 11.9/8.9kts, 14p, 30m; 3-450TT
	A2	3	2	A2	1914		268/342t, 46.5x4.8x2.7m, 2d/em, 700/380hp, 14.5/9kts, 17p, 50m; 3-450TT
			3	A3	1914		
			4	A4	1914		
	B1	5	5	B1	1923		/545t, 51.0x5.3x3.5m, 2d/em, 900/700hp, 14.5/10.5kts, 23p, 60m; 1x1-76/28, 4-450TT
			6	B2	1924		
			7	B3	1926		
			8	B4	1927		
			9	B5	1929		

## ESCORTS





PC	Djerv	2	1, 2	Djerv, Dristig	1897-1898		66t, 34.5x3.8x1.7m, 2b, 1vte, 650hp, 19kts, 21p; 2x1-37/45, MS
----	-------	---	------	----------------	-----------	--	--

## OTHER FIGHTING SHIPS

PG	Æger	1	1	Æger	1894		413t, 33.2x8.8x2.4m, 2b, 2vte, 350hp, 9kts, 43p; 38deck; 1x1-209/35, 1x1-75/55, 2x1-47/50
----	------	---	---	------	------	---	---

## MINE WARFARE

--	--	--	--	--	--	--	--

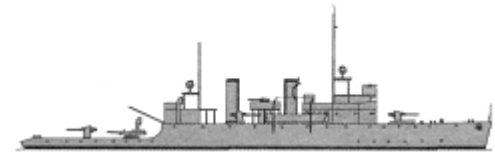
ML	Vale	2	1	Vale	1874		250t, 27.3x7.9x2.2m, 2b, 2vte, 200hp, 8kts, 38p; 1x1-120/44, 1x1-37/45, 50mines
			2	Uller	1877		
	Brage	2	3	Brage	1879		270t, 28.9x7.9x2.2m, 2b, 2vte, 220hp, 8.5kts, 38p; 1x1-149/46, 1x1-47/46, 1x1-37/45, 50mines
			4	Nor	1879		
	Vidar	1	5	Vidar	1882		270t, 28.9x7.9x2.2m, 2b, 2vte, 330hp, 9.5kts, 38p; 1x1-149/46, 1x1-47/46, 1x1-37/45, 50mines
	Gor	2	6	Gor	1885		290(6)-278(7)t, 31.3x8.0x2.2m, 420hp, 10.5kts; 1x1-120/44, 1x1-76/28(1), 1x1-47/46(2), 55mines
			7	Tyr	1887		
	Frøya	1	8	Frøya	1917		755t, 75.6x8.2x2.8m, 2b, 2vte, 7000hp, 21.8kts, 78p; 4x1-102/40, 1x2-450TT, 180mines
	Glommen	2	9	Glommen	1917	No picture	380t, 42.0x8.5x2.1m, 1b, 1vte, 170hp, 9.9kts, 35p; 2x1-76/28, 120mines
			10	Laugen	1918		

[home](#)

[World navies yesterday](#)

[1930](#)

## Paraguay 01 January 1930

### ESCORTS

APC	-	2	1	Capitán Cabral	1907	206t; 1x1-76/40
			2	Tacuari	1910	150t; 2x1-76/50, 2x1-76/40

© Ivan Gogin, 2011-15



[home](#)[World navies yesterday](#)[1930](#)

## Persia 01 January 1930

### OTHER FIGHTING SHIPS

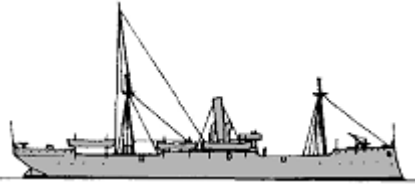
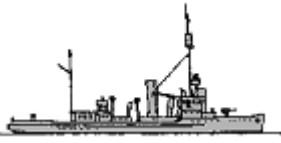
PG	Persepolis	1	1	Persepolis	1885		1200t, 63.1x10.0x5.9m, 1vte, 450hp, 10kts; 1x1-102/40, 2x1-87/25, 2x1-37/32
	Muzaffer	1	2	Muzaffer	1899	No picture	379t, 41.1x7.9x4.0m
	Fathiya	1	3	Pahlavi	1919		193t, 43.0x6.0x1.4m, 1b,2vte, 600hp, 14kts, 35p; 1x1-76/40

© Ivan Gogin, 2011-15

[home](#)[World navies yesterday](#)[1930](#)

## Peru 01 January 1930

### CRUISERS

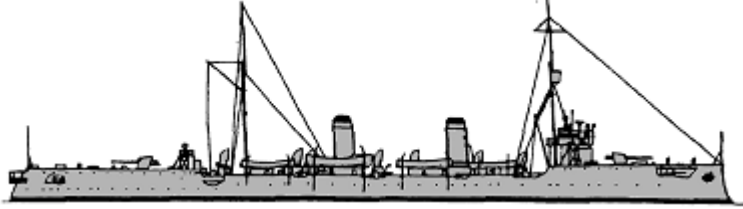
CL	Almirante Grau	1	Almirante Grau	1907		4877t, 115.8x12.3x4.3m, 10b,2vte, 14000hp, 24kts, 320p; 38belt, 38deck, 76shields, 76CT; 2x1-152/50, 6x1-76/40, 6x1-57/40, 2x1-37/23, 2-450TT
		2	Coronel Bolgnesi	1907		

### TORPEDO SHIPS

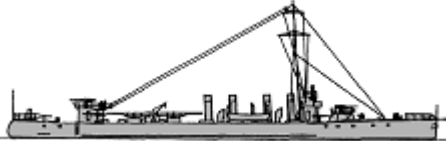
DD	Teniente Rodríguez	1	1	Teniente Rodríguez	1911		520t, 64.6ppx6.5x3.1m, 4b,3t, 8600hp, 28kts, 79p; 6x1-65/50, (1+2x1)-450TT
----	--------------------	---	---	--------------------	------	--	--

### SUBMARINES

SS	R1	4	1	R1	1926		576/755t, 56.8x5.3x4.6m, 2d/em, 800/1000hp, 14.5/9.5kts, 30p, 60m; 1x1-76/50, 4-533TT
			2	R2	1926		
			3	R3	1928		
			4	R4	1928		

### OTHER FIGHTING SHIPS



PGR	Iquitos	1	1	Iquitos	1875	No picture	50t, 23.4x3.7x1.2m, 7.5kts; 1x1-47/40
	América	1	2	América	1904	No picture	240t, 40.5x5.9x1.4m, 2b,2vte, 350hp, 14kts, 26p; 4x1-47/40
	Napo	1	3	Napo	1920	No picture	98t, 30.9x5.5x0.9m, 1b,1vte, 250hp, 12kts, 22p; 4x1-47/40, 2x1-37/23

© Ivan Gogin, 2012-15

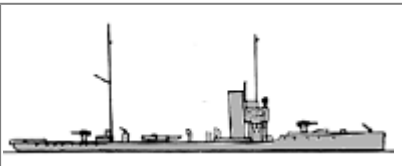

[home](#)[World navies yesterday](#)[1930](#)

# POLAND 01 January 1930

## TORPEDO SHIPS

TB	Ślązak	4	1	Ślązak	1917		381(1,2,4)-392(3)t, 61.1(1,2)-60.0(3)-60.4(4) x6.4x2.2(1,2)-2.3(3)-2.1(4)m, 2b,2t, 6000(1-3)-5700(4)hp, 28(1-3)-26(4)kts, 50(1-3)-55(4)p; 2x1-75/34, 2x1-450TT
			2	Krakowiak	1918		
			3	Kujawiak	1917		
			4	Góral	1917		
	Mazur	1	5	Mazur	1915		421t, 62.6x6.2x2.5m, 4b,2t, 5500hp, 28kts, 60p; 2x1-75/34, 2x1-450TT

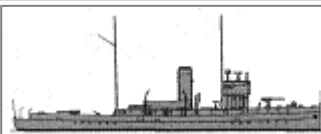
## OTHER FIGHTING SHIPS

PG	Generał Haller	2	1	Generał Haller	1921		441t, 50.1x6.8x2.3m, 2b,2vte, 1150hp, 15kts, 49p; 2x1-75/34, 2x1-47/43
			2	komendant Piłsudski	1921		
RMON	Warszawa	4	1	Horodyszczce	1920		126t, 34.7x5.1x0.8m, 3d, 180hp, 10kts, 49p; 6belt, 10deck, 10turrets; 1x1-100/19, 1x2-75/36
			2	Pińsk	1920		
			3	Toruń	1920		
			4	Warszawa	1920		
	Kraków	2	5, 6	Kraków, Wilno	1926		90t, 35.0x6.1x0.4m, 2d, 140hp, 7.3kts, 29p; 6belt, 5deck, 8turrets, 8CT; 1x1-100/19, 1x2-75/36

## MINE WARFARE SHIPS

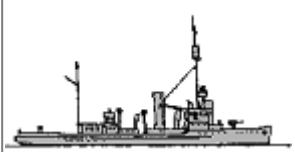
MS	Czajka	4	1	Czajka	1918		193t, 43.0x6.0x1.4m, 1b,2vte, 600hp, 14kts, 35p; 1x1-47/43, 20m, MS
			2	Jaskółka	1918		
			3	Mewa	1918		
			4	Rybitwa	1918		

© Ivan Gogin, 2011-15

[home](#)[World navies yesterday](#)[1930](#)

## PORTUGAL 01 January 1930

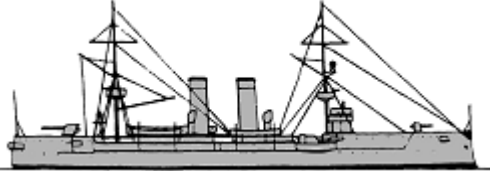

### CAPITAL SHIPS

BC	Vasco da Gama	1	1	Vasco da Gama	1876		3200t, 70.9ppx12.2x6.3m, 4b,2vte, 6000hp, 15.5kts, 260p; steel: 250belt, 75deck, 200shields; 1x1-203/40, 1x1-152/45, 1x1-102/40, 6x1-47/40
----	---------------	---	---	---------------	------	--	--

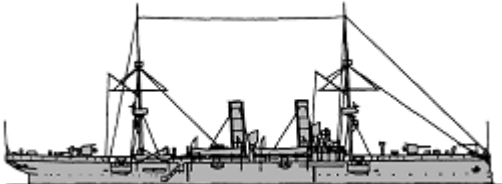
### CRUISERS

CL	Adamastor	1	1	Adamastor	1897		1757t, 74.0ppx10.7x4.7m, 4b,2vte, 4000hp, 18kts, 237p; 30deck, 65CT; 2x1-120/40, 4x1-105/40, 4x1-67/40, 2x1-37/20, 3-356TT
----	-----------	---	---	-----------	------	--	--

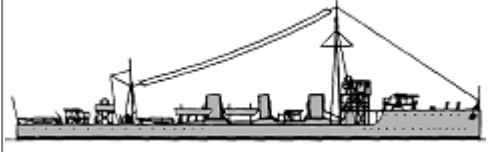
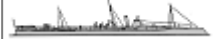

### TORPEDO SHIPS

DD	Guadiana	4	1	Douro	1913		660t, 73.2x7.2x2.3m, 3b,2t, 11000hp, 27kts, 80p; 1x1-100/41, 2x1-76/40, 2x2-450TT
			2	Guadiana	1914		
			3	Vouga	1920		
			4	Tâmega	1923		
TB	N°2	1	1	N°2	1886		65t, 36.5ppx3.9x1.0m, 1b,1vc, 700hp, 19kts, 85p; 2x5-37/20, 2-356TT
	82F	4	2	Ave	1916		330t, 58.8x5.8x1.5m, 2b,2t, 5000hp, 28kts, 38p; 1x1-66/30, 1x1-57/40, 2x2-450TT
			3	Sado	1916		
			4	Liz	1916		
			5	Mondego	1916		



### SUBMARINES

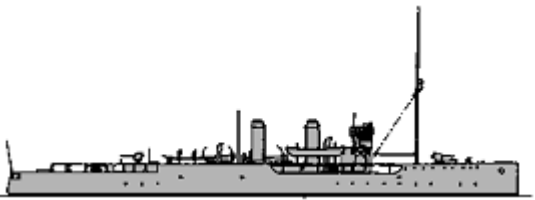
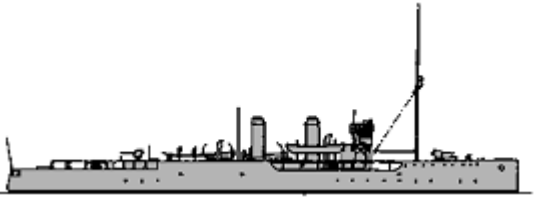

SS	Espadarte	1	1	Espadarte	1913	No picture	245/300t, 45.1x4.2x2.9m, 2d/em, 550/300hp, 13.8/8kts, 21p; 2-450TT
	Foca	3	2	Foca	1917		262/382t, 45.6x4.2x3.1m, 2d/em, 550/400hp, 14.2/8.2kts, 21p, 40m; 2-450TT
			3	Golginho	1917		
			4	Hidra	1917		

## ESCORTS

SL	República	1	1	República	1915		1350t, 81.7x10.2x3.4m, 2b,1vte, 2000hp, 16kts, 137p; 2x1-102/40, 2x1-76/40, 4x1-47/40
	Carvalho Araujo	1	2	Carvalho Araujo	1915		1275t, 80.0x10.1x3.4m, 2b,1vte, 1800hp, 16.5kts, 137p; 2x1-102/40, 2x1-76/40, 4x1-47/40, 2DCT
PC	Dili	1	1	Dili	1910s	No picture	495t, 42.7ppx7.6x3.1m, 1vce, 500hp, 11kts, 72p
	Lince	1	2	Lince	1911	No picture	77t, 27.0ppx4.3x1.8m, 2sd, 300hp, 12kts, 20p
	Torres Garcia	1	3	Torres Garcia	1928	No picture	250t, 28.0xxm, 1b,1vte,
FPV	Faro	1	1	Faro	1928		300t, 39.8x6.7x3.2m, 1b,1vte, 650hp, 13kts, 52p; 2x1-47/40

## OTHER FIGHTING SHIPS

PG	Limpopo	1	1	Limpopo	1890	No picture	288t, 37.8x6.4x2.0m, 1b,1vc, 520hp, 11.3kts, 54p; 3x1-57/40
	Pátria	1	2	Pátria	1905		626t, 60.0ppx8.3x2.5m, 4b,2vte, 1800hp, 16.7kts, 95p; 12deck; 4x1-100/41, 6x1-47/40
	Lúrio	2	3	Lúrio	1907		305t, 42.8x7.2x1.8m, 2b,2vte, 500hp, 12.5kts, 51p; 2x1-47/40
			4	Save	1908		
	Beira	5	5	Beira	1910		
			6	Ibo	1911		
			7	Mandovi	1917		
			8	Bengo	1917		
			9	Quanza	1917		
	Zaire	3	10	Zaire	1925		492t, 45.0x8.3x2.1m, 2b,2vte, 700hp, 13kts, 67p; 2x1-76/40, 2x1-47/40
			11	Damao	1927		

						
		12	Diu	1929		
APG	-	-	1	Açor	1874	330t
PR	Rio Minho	1	1	Rio Minho	1904	No picture 38t, 24.6x4.0x0.6m, 1b,vte(sw), 64hp, 7.5kts, 8p; 1x1-37/20
	Flecha	1	2	Flecha	1909	No picture 44t, 21.0x4.0x0.7m, 1b,vte(sw), 45hp, 10kts, 7p; 1x1-37/20
	Macau	1	3	Macau	1910	 133t, 36.5x6.0x0.7m, 1b,1vte, 250hp, 11.8kts, 24p; 2x1-57/40
	Tête	1	4	Tête	1920	No picture 130t, 23.4x6.1x0.7m, 1b,1vt2(sw), 70hp, 8kts, 20p; 2x1-47/40

## COASTAL FORCES

YP	Nº2	2	1, 2	Nº2, 3	1918		37t, 24.4x3.7x1.2m, 2pe, 440hp, 19kts, 8p; 1x1-47/40, 2DCR, MS
----	-----	---	------	--------	------	---	--

## MINE WARFARE SHIPS

ML	Vulcano	1	1	Vulcano	1910		151t, 33.5x5.9x1.3m, 1b,2vte, 412hp, 12kts, 24p; 50m
----	---------	---	---	---------	------	--	--





© Ivan Gogin, 2011-14

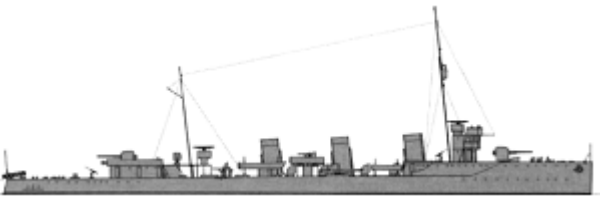

[home](#)[World navies yesterday](#)[1930](#)

## Romania 01 January 1930

### TORPEDO SHIPS



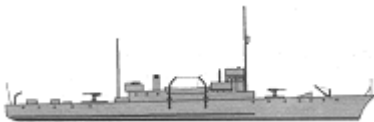

DD	Mărăști	1	Mărăști	1917		1723t, 94.7x9.5x3.5m, 5b,2t, 45000hp, 34kts, 139p; (2x2+1x1)-120/45, 2x1-76/40, 2x2-450TT, 50m
		2	Mărășești	1918		
TB	Viforul	1	Viforul	1914		320t, 58.2x5.7x1.5m, 2b,2t, 5000hp, 28kts, 41p; 2x1-66/30, 2x2-450TT
		2	Vartejul	1914		
		3	Vijelia	1914		
		4	Sborul	1914		
	Naluca	5	Naluca	1916		330t, 58.8x5.8x1.5m, 2b,2t, 5000hp, 28kts, 41p; 2x1-66/30, 2x2-450TT
		6	Smeul	1916		
TBR	Căpitan Nicolae Lascăr Bogdan	1 - 7	Major Ene Constantin, Căpitan Nicolae Lascăr Bogdan, Căpitan Romani Michail, Major Giurascu Dimitrie, Major Sontu Gheorge, Major Grigore Ioan, Locotenent Calinescu Dimitrie	1906 - 1907		51t, 30.4x4.0x0.8m, 2b,2vce, 550hp, 18kts, 20p; 1x1-47/44, 2spar torpedoes

### ESCORTS

FS	Căpitan Dumitrescu	1	Căpitan Dumitrescu	1917		443t, 60.2x7.0x2.6m, 2d, 900hp, 14.5kts, 50p; 2x1-100/45, 2DCT
		2	Locotenent-Comandor Stihl Eugen	1917		
		3	Locotenent Lepri Remus	1918		
		4	Sublocotenent Ghiculescu	1918		

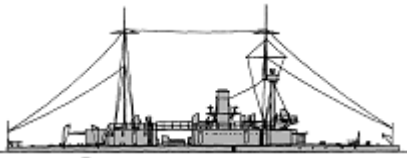
### OTHER FIGHTING SHIPS

		1	Ion C. Brătianu	1907		
		2	Lascar Catargiu	1907		

MONR	Ion C. Brătianu	4	3	Alexandru Lachovari	1908		750t, 62.0-63.5x10.5x1.8m, 2b,2vte, 1800hp, 13kts, 110p; 70belt, 70deck, 75turrets, 75CT; 3x1-120/35, 2x1-120/10, 4x1-47/44
			4	Mihail Kogălniceanu	1907		
	Ardeal	1	5	Ardeal	1905		650t, 60.3x9.5x1.6m, 2b,2vte, 1400hp, 13kts, 89p; 40belt, 25deck, 75turrets, 40CT; 2x1-120/50, 2x1-90/45
	Bucovina	1	6	Bucovina	1915		~700t, 62.2x10.3x1.3m, 2b,2vte, 1750hp, 13.5kts, 91p; 40belt, 25deck, 50turrets, 50CT; 1x2-120/40, 2x1-120/10, 2x1-66/50, 2x1-47/44
Basarabia	1	7	Basarabia	1915		770t, 62.0x10.5x1.8m, 2b,2vte, 1600hp, 12.2kts, 133p; 40belt, 35deck, 50turrets, 40CT; 1x2-120/40, 3x1-120/10, 2x1-66/50	
FBR	MR491	6	1	MR491	1916		255t, 54.7x7.1x1.2m, 2sd, 100hp, 5.5kts; 1x1-152/45(4-6), 2x1-120/45(1-3)
			2	MR492	1916		
			3	MR493	1916		
			4	MR494	1916		
			5	MR495	1916		
			6	MR496	1916		



## COASTAL FORCES

PS	M1	2	1, 2	VAS1, 2	1918		44t, 24.4x3.7x1.2m, 2pe, 460hp, 17kts, 15p; 1x1-76/40, 2DCR
	M3	5	3-5	VAS3-7	1920		45t, 24.4x3.7x1.3m, 2pe, 460hp, 19kts, 15p; 1x1-76/40, 2DCR

[home](#)[World navies yesterday](#)[1930](#)

# Siam 01 January 1930

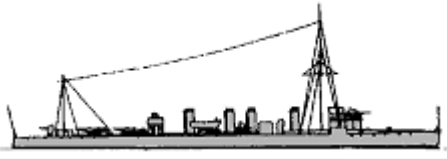
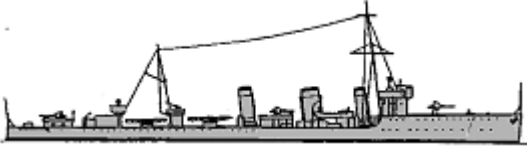
## TORPEDO SHIPS



DD	Sua Tayanchon	1	Sua Tayanchon	1908		385t, 69.2ppx6.6x1.8m, 4b,2vte, 6000hp, 27kts, 75p; 1x1-76/40, 5x1-57/40, 2x1-450TT
		2	Sua Khamronsin	1912		
	Phra Ruang	1	Phra Ruang	1917		1208t, 83.6x8.3x2.7m, 3b,2gt, 27000hp, 36kts, 82p; 3x1-102/40, 1x1-76/40, 1x1-40/39, 2x2-533TT
TB	No1	1	No1	1908		100t, 41.1x4.9x2.1m, 2b,1vte, 1200hp, 23kts, 29p; 1x1-57/40, 1x1-47/43, 2x1-450TT
		2	No2	1908		
		3	No3	1908		
		4	No4	1913		

## ESCORTS

SL	Chow Phraya	1	Chow Phraya	1919		840t, 70.4x8.7x2.2m, 2b,2vte, 2200hp, 16kts, 65p; 1x1-102/40, 1x1-76/40
----	-------------	---	-------------	------	--	---

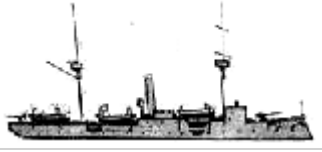
## OTHER FIGHTING SHIPS

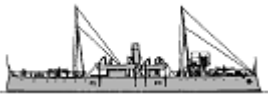
PG	Mongkut Rajakumarn	1	Mongkut Rajakumarn	1887	No picture	700t, 53.3x7.2x3.4m, 2b,2vte, 800hp, 14kts, 100p; 2x1-120/40, 4x1-57/40, 3x1-37/23, 1-356TT
	Muratha	2	Bali	1900		580t, 49.4x7.0x3.1m, 2b,2vte, 500hp, 11.4kts, 83p; 1x1-120/40, 5x1-57/40, 4x1-37/23
		3	Sugrib	1901		

	Sri Monthon	1	4	Sri Monthon	1908		225t, 41.8x5.5x2.0m, 1b,2vte, 750hp, 14.5kts, 34p; 2x1-57/40
	Ratanakosindra	1	5	Ratanakosindra	1925		1000t, 53.0x11.3x3.3m, 2b,2vte, 850hp, 12kts, 102p; 57belt, 50deck, 38turrets, 120CT; 2x1-152/50, 4x1-76/40

## COASTAL FORCES

PT	No1	5	1-5	No1-5	1922		14t, 16.8x3.4x1.1m, 2pe, 750hp, 37kts, 5p; 2-450TT
----	-----	---	-----	-------	------	---	--

© Ivan Gogin, 2011-15

[home](#)

[World navies yesterday](#)

[1930](#)

## SOUTH AFRICA 01 January 1930

### MINE WARFARE

TR	Mersey	2	1	Sonneblom	1918		665t, 45.1x7.2x2.8m, 1b, 1vte, 600hp, 11kts, ?p; 1x1-76/40, MS
			2	Immortelle	1918		

© Ivan Gogin, 2010-15

[home](#)[World navies yesterday](#)[1930](#)

## SOVIET UNION 01 January 1930

*IN SERVICE: 3 battleships, 1 river seaplane tender, 2 protected cruisers, 2 light cruisers, 17 destroyers, 14 submarines, 12 gunboats, 7 dispatch vessels, 8 auxiliary dispatch vessels, 5 river monitors, 5 river gunboats, 2 auxiliary river gunboats, 25 motor torpedo boats, 8 patrol motor launches, 14 armoured river motor gunboats, 4 minelayers, 1 auxiliary minelayer, 1 river minelayer, 8 minesweepers, 6 auxiliary minesweepers, 5 Board Guard ships, 2 auxiliary Board Guard ships, 8 Board Guard launches*

### CAPITAL SHIPS

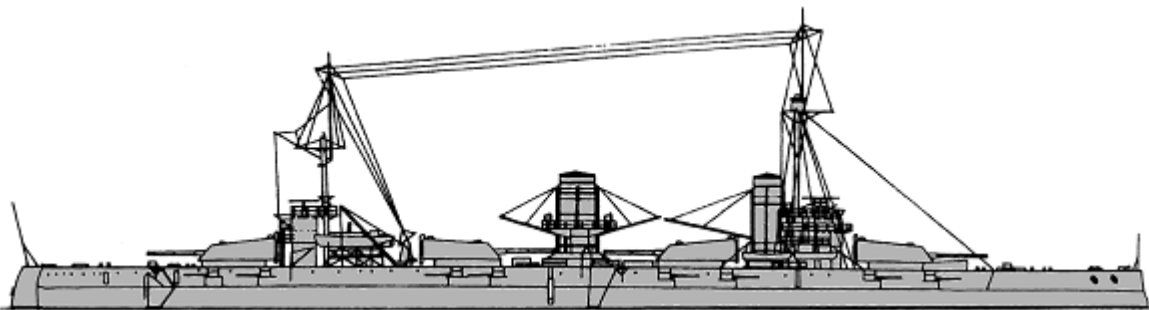
BB	Sevastopol	1	Oktyabrskaya Revolyutsiya	1914		26900t, 181.2(1,3)-184.9(2)x26.9x8.4m, 25b,4t, 42000hp, 23kts, 1140p; 225belt, 75deck, 305turrets, 250CT; 4x3-305/52, 16x1-120/50, 6x1-76/30, 4-450TT
		2	Parizhskaya Kommuna	1914		
		3	Marat	1915		

### AIRCRAFT CARRYING SHIPS

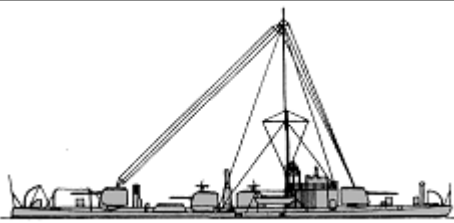
AVR	Tayfun	1	1	Amur	1910		1000t, 70.9x12.8x1.4m, 4d, 1000hp, 10kts, 117p; 76belt, 19deck, 76turrets, 51CT; 4seaplanes
-----	--------	---	---	------	------	--	---

### CRUISERS

	Pallada	1	1	Avrora	1903		6897t, 126.8x16.8x6.4m, 24b,3vte, 11610hp, 19.2kts, 570p; nickel steel: 38/63deck, 25shields, 152CT; 10x1-130/55, 4x1-76/30, 126m
--	---------	---	---	--------	------	--	---

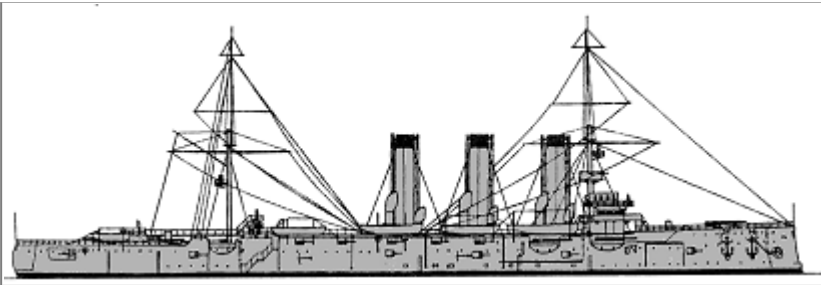
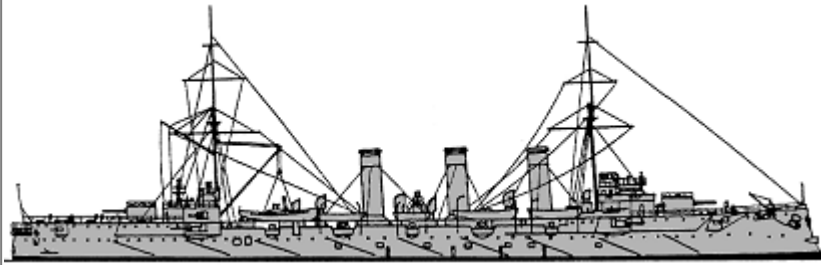
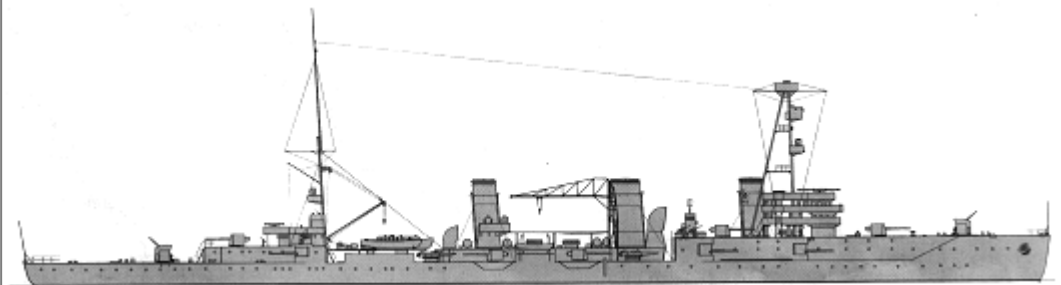
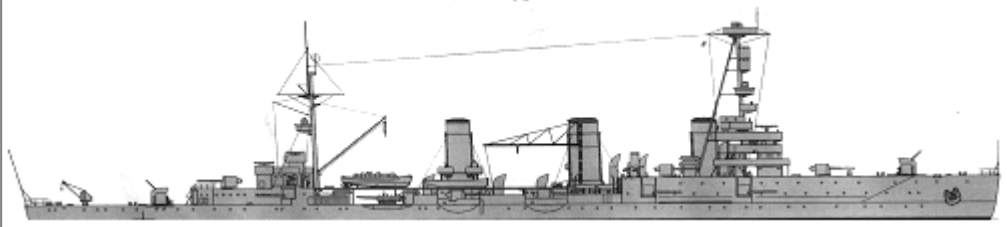
CL						
	Bogatyr	1 2	Komintern	1905		7790t, 134.0x16.6x6.3m, 16b,2vte, 19500hp, 23kts, 581p; 35/70deck, 127turrets, 80casemates, 140CT; 16x1-130/55, 2x1-47/43, 2-450TT, 290m
	Admiral Nakhimov	1 3	Chervona Ukraina	1927		8268t, 166.8x15.7x6.2m, 14b,4t, 55000hp, 29kts, 830p; 75belt, 40deck, 25shields, 75CT; 15x1-130/55, 4x1-75/50, 2-450TT, 90m, 1seaplane (MU-2)
	Svetlana	1 4	Profintern	1928		8041t, 158.4x15.4x6.7m, 13b,4t, 46300hp, 29kts, 830p; 75belt, 40deck, 25shields, 75CT; 15x1-130/55, 4x1-75/55, 3x3-450TT, 90m, 1seaplane (MU-2)

## TORPEDO SHIPS

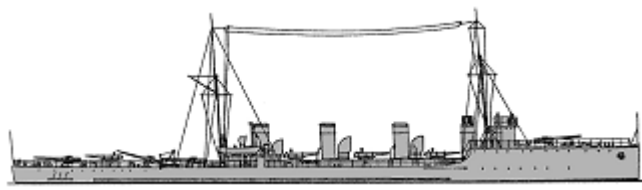
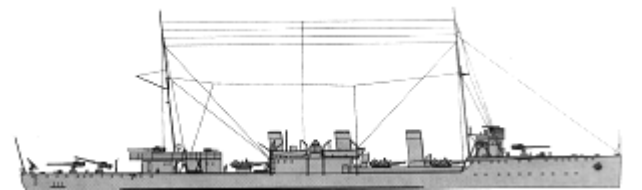
	Novik	1 1	Yakov Sverdlov	1913		1595t, 102.4x9.5x3.5m, 6b,3t, 35100hp, 36kts, 113p; 4x1-102/60, 1x1-76/30, 3x3-450TT, 2DCR, 58m
	Schastlivy	1 2	Frunze	1915		1450t, 98.0x9.3x3.4m, 5b,2t, 23000hp, 34kts, 112p; 4x1-102/60, 1x1-76/30, 3x3-450TT, 2DCR, 40m
	Pobeditel	3	Volodarskiy	1915		1450t, 98.0x9.3x3.2m, 4b,2t, 30000hp, 35kts, 112p; 4x1-102/60, 1x1-76/30(3,4), 1x1-40/39(5-7), 3x3-450TT, 2DCR(3,4), 58m(3,4), 80m(5-7)
		4	Uritskiy	1915		
		5	Engels	1916		

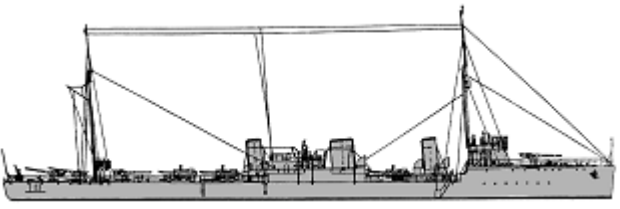
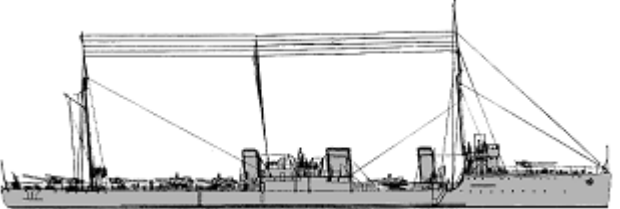
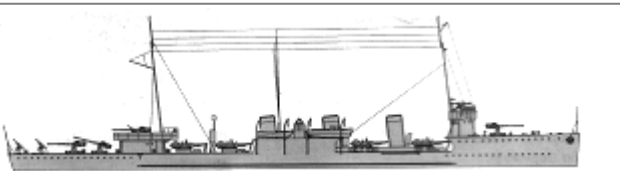
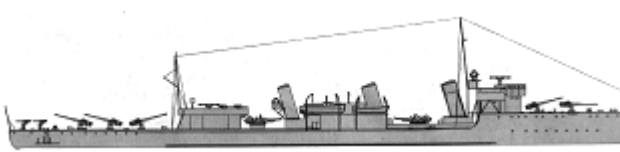

DD		6	Artyom	1916			
		7	Stalin	1916			
		8	Lenin	1916			
	Kapitan Izlymetyev	4	9	Voykov	1916		1450(8,9)-2020(10,11)t, 98.0x9.3x3.9(8,9)-4.0(10,11)m, 4b,2t, 31500hp, 34kts, 150p; 4x1-102/60, 1x1-76/30, 3x3-450TT, 2DCT(10,11), 2DCR(8,10,11), 58(8)-80(9)-50(10,11)m
			10	Rykov	1927		
			11	Karl Libknekht	1928		
	12		Dzerzhinskiy	1917			
	Fidonisi	4	13	Nezamozhnik	1923		1760t, 92.5x9.1x3.8m, 5b,2t, 29000hp, 33kts, 136p; 4x1-102/60, 2x1-76/30, 4x3-450TT, 2DCR, 60m
			14	Petrovskiy	1925		
			15	Shaumyan	1925		
	16		Karl Marx	1917			
	Izyaslav	2	17	Kalinin	1927		1570t, 107.0x9.5x4.1m, 5b,2t, 32700hp, 35kts, 150p; 5x1-102/60, 1x1-76/30, 3x3-450TT, 80m

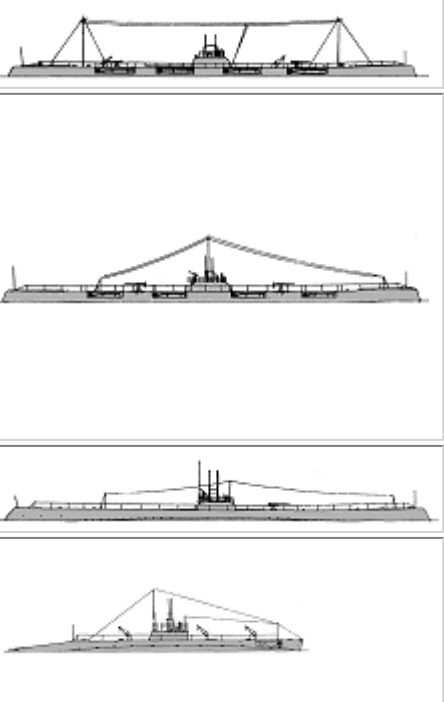

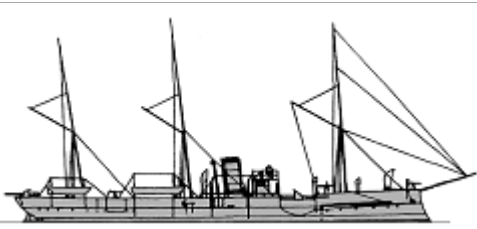
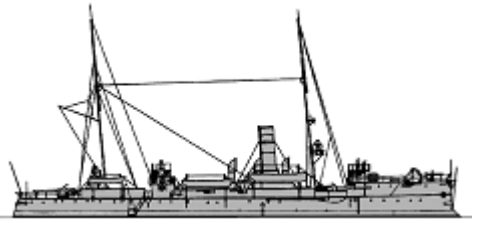
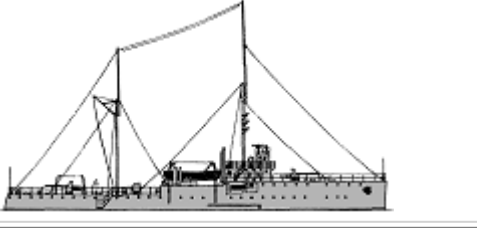
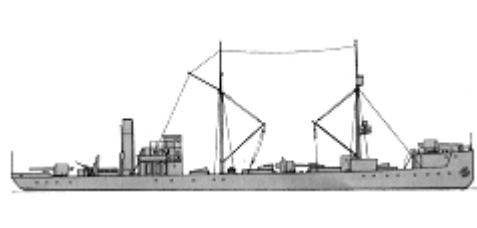
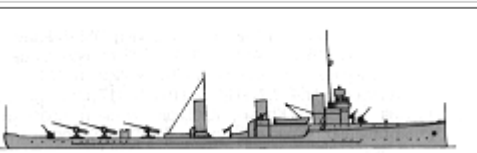
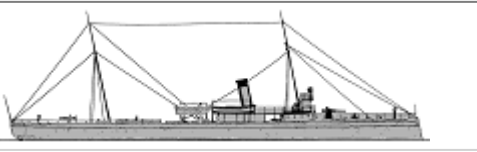
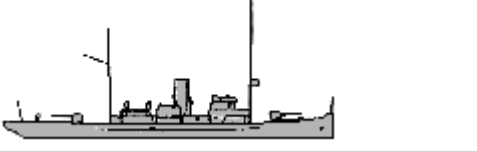

## SUBMARINES

SS	Morzh	1	1	Politrak	1915		642/773t, 67.4x4.4x4.0m, 2d/em, 500/800hp, 10.8/8kts, 47p, 50m; 1x1-57/40, 1x1-47/43, 12-450TT
	Bars	8	2	Kommunar	1916		
			3	Batrak	1916		
			4	Komissar	1916		
			5	Bolshevik	1916		
			6	Krasnoarmeets	1917		
			7	Proletariy	1917		
			8	Tovarishch	1917		
	Yorsh	1	10	Rabochiy	1917		
				11	Shakhtyor		
	AG	4	12	Kommunist	1921		
			13	Marxist	1922		
			14	Politrabotnik	1923		

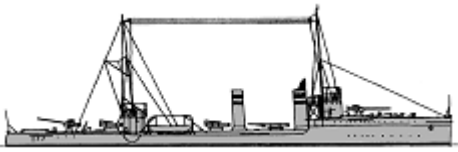

## OTHER FIGHTING SHIPS

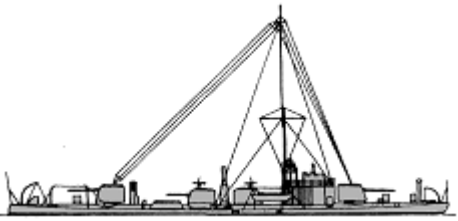

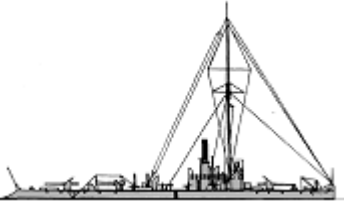
PG	Kubanets	1	1	Znamya Sotsializma	1887		1505t, 67.2x12.2x3.6m, 6b,2hc, 1500hp, 14kts, 180p; 3x1-130/55, 2x1-76/30, 2x1-47/43, 2-381TT
	Khrabry	1	2	Krasnoye Znamya	1897		2100t, 72.3x12.7x3.4m, 8b,2vte, 2100hp, 14kts, 188p; Harvey steel: 127belt, 38deck, 38shields, 25CT; 5x1-130/55, 11x1-47/43, 1-450TT, 20m
	Kars	2	3	Lenin	1910		635t, 61.6x8.5x2.6m, 2d, 1000hp, 14kts, 128p; 2x1-102/60, 1x1-102/60, 2x1-76/30
			4	Krasny Azerbaydzhan	1910		
	Elpidifor	4	5	Krasnaya Abkhaziya	1920		1300t, 74.7x10.4x1.8m, 2b,2vte, 750hp, 8.5kts, 169p; 3x1-130/55, 2x1-76/30, 180m, MS; 2000troops or 6 light tanks
			7	Krasny Adzharistan	1921		
			8	Krasny Krym	1924		
			9	Krasnaya Gruziya	1923		
	Ukrayna	3	10	Bakinskiy Rabochiy	1905		880t, 73.2x7.2x3.4m, 4b,2vte, 7000hp, 26kts, 88p; 3x1-102/60, 1x1-76/30(11,12), 1x1-40/39(10), 1x1-37/23(10), 2x1-450TT(10)
			11	Markin	1905		
12			Altfater	1905			
DV	Abrek	1	1	Abrek	1897		675t, 65.5x7.8x3.4m, 4b,2vte, 4500hp, 21.2kts, 88p; 4x1-75/50, 1x1-37/23
	Kopchik	1	2	Pioner	1916		550t, 51.2x7.3x2.9m, 3b,2vte, 1500hp, 15kts, 57p; 2x1-102/60, 1x1-76/30, 30m
	Inzhener-Mekhanik Zverev	2	3	Zhemchuzhin	1906		540t, 63.6x7.0x2.7m, 4b,2vte, 6000hp, 27kts, 65p; 2x1-75/50
			4	Artemyev	1906		
Vsadnik	1	5	Zheleznyakov	1907		930t, 71.9x7.2x2.4m, 4b,2vte, 6500hp, 99p; 2x1-102/60, 1x1-37/23	

							
	Dozorny	1	6	Razvedchik	1905		100t, 30.8x5.0x1.7m, 2b,1vte, 660hp, 16kts, 31p; 1x1-37/23
	Berezina	1	7	Yauza	1918	No picture	450t, 50.7x16.7x2.0m, 2d(sw), 600hp, 7.5kts, 47p; 2x1-75/50
ADV		8	1	Polyarnaya Zvezda	1891		3949t; 106.5x13.8x5.2m, 6000hp, 17kts; 4x1-47/43
			2	Shtandard	1896		5557t, 112.8x15.4x6.6m, 12000hp, 20kts; 8x1-47/43
			3	Izhora	1913		210t
			4	Minyor	1914		150t
			5	Yakobinets	1905		140t
			6	Kingisepp	1900		212t
			7	Krasny Adzharets	1900		100t
			8	Krasny Vympel	1911		700t; 4x1-75/50
RMON	Tayfun	5	1	Tayfun	1910		1000t, 70.9x12.8x1.4m, 4d, 1000hp, 10kts, 117p; 76belt, 19deck, 76turrets, 51CT; 2x1-152/50(1), 4x1-152/50(3,4), 2x2-120/50(1), 4x2-120/50(2,5), 2x1-76/30(2-5)
			2	Lenin	1910		
			3	Krasny Vostok	1910		
			4	Sverdlov	1910		
			5	Sun-Yat-Sen	1910		
PGR	Buryat	2	1	Buryat	1907		288t, 54.5x8.2x0.9m, 2b,2vte, 480hp, 11.5kts, 40p; 12belt, 5deck, 8CT; 2x1-76/40(1), 2x1-75/50(2), 2x1-47/43(2)
			2	Mongol	1907		
	Vogul	3	3	Bednota	1909		349t, 54.5x8.2x1.2m, 2b,2vte, 480hp, 10.5kts, 63p; 13belt, 9deck, 13CT; 2x1-120/45(5), 2x1-102/60(3,4), 1x1-76/30
			4	Proletariy	1909		
			5	Krasnoye Znamya	1909		
APR		2	1	Verny	1898		350t; 2x1-102/60, 1x1-76/30
			2	Peredovoy	1891		328t; 2x1-102/60, 1x1-76/30







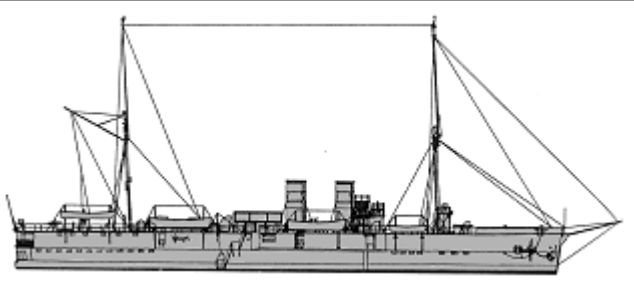
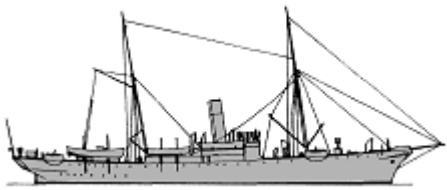
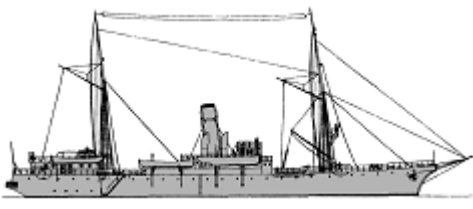

## COASTAL FORCES

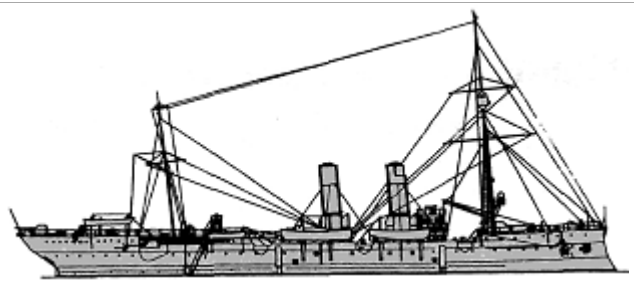
PT	No1	5	1 - 5	No1, 2, Pilot, 6, No7, 9	1906		35t, 27.4x3.7x1.5m, 2pe, 600hp, 20kts, 11p; 1x1-47/43, 1x1-450TT
	CMB-40	5	6 - 10	No1,3-6	1916 - 1918		5t, 13.7x2.6x0.9m, 1pe, 275hp, 37.8kts, 4p; 1-450TT
	ANT-3	1	11	Pervenets	1927		9t, 17.3x3.3x0.9m, 2pe, 1200hp, 54kts, 3p; 1-450TT, 2m
							10t, 16.8x3.3x0.8m, 2pe, 1200hp, 50.5kts, 5p; 2-

	ANT-4	1	12	No14 Tupolev	1928		450TT, 2m
	Sh-4	13	13 - 25	No11 Revolyutsionny Metallist, No21 Osoaviakhimovets, No24, No31 Sibiryak, No34, No41 Proletariy Ukrainy, No44, 51, 54, 61, 64, 71, 81	1928 - 1929		10t, 16.8x3.3x1.0m, 2pe, 1200hp, 45kts, 5p; 2-450TT
YP	Greenport-1	1	1	Pronzitelny	1916		15t, 18.3x3.1x0.9m, 3pe, 525hp, 21kts, 8p; 1x1-47/43, 1x1-37/23
	Greenport-3	2	2, 3	Pylkiy, Prochny	1916 - 1917		15t, 18.3x3.1x0.9m, 3pe, 525hp, 21kts, 8p; 1x1-47/43, 1x1-37/23
	Greenport-4	2	4, 5	No1, 3	1916 - 1917		24t, 22.0x3.4x0.6m, 3pe, 1080hp, 30kts, 8p; 1x1-47/43, 1x1-37/23
	Zolotov/SPOPiT	2	5, 6	Lyogkiy, Lovkiy	1916 - 1917		16t, 16.8x2.8x1.1m, 2pe, 250hp, 20kts, 15p; 1x1-47/43
	MI-8	2	7, 8	MI-12, 13	1919	No picture	39t, 21.0x3.2x2.0m, 2pe, 160hp, 12kts, 12p; 1x1-47/43
PGRA	Kopyo	2	1, 2	Kopyo, Pika	1910		25t, 22.2x3.1x0.5m, 2pe, 200hp, 14.5kts, 12p; 8belt, 8deck, 8CT: 1x1-76/16
	K	4	3 - 6	K-1, 3-5	1917		25t, 20.4x3.2x0.6m, 2pe, 150hp, 12.5kts, 12p; 5belt, 4deck, 6shields, 6CT; 2x1-76/16
	N	4	7 - 10	N-1-4	1916 - 1917		18t, 15.2x3.1x0.7m, 2pe, 100hp, 11.5kts, 8p; 7belt, 5deck, 7turret, 7CT; 1x1-76/16
	D	4	11 - 14	D-1-4	1916 - 1917		7t, 9.2x2.4x0.7m, 1pe, 80hp, 10.5kts, 7p; 5belt, 6turret, 6CT

## MINE WARFARE SHIPS

ML	General-Admiral	1	1	25 Oktyabrya	1875		5031t, 91.0x14.6x7.0m, 6b,1vc, 4470hp, 12.3kts, 490p; iron: 152belt, 25deck; 2x1-75/50, 2x1-47/43, 8x1-37/20, 1-381TT, 500m
	Bug	1	2	1 Maya	1893		1490t, 62.2x10.4x4.6m, 4b,2vte, 13kts, 226p; 1x1-76/30, 350m
	Volga	1	3	9 Yanvarya (TS)	1909		1711t, 70.3x11.9x4.4m, 4b,2vte, 1600hp, 13.5kts, 219p; 4x1-47/43, 230m

	Amur	1	4	Amur	1909		2926t, 98.9x14.0x4.4m, 12b,2vte, 5000hp, 16kts, 312p; 5x1-120/45, 2x1-75/50, 320m
AML	-	1	1	Mina	1913		180t; 80m
MLR	Silny	1	1	Silny	1910		300t, 55.7x16.6x1.5m, 1b,1vc, 450hp, 10kts, 71p; 1x1-76/30, 100m
MS	Inzhener-Mekhanik Zverev	1	1	Martynov (TS)	1906		540t, 63.6x7.0x2.7m, 4b,2vte, 6000hp, 27kts, 65p; 2x1-75/50, MS, 16m
	Dozorny	1	2	Dozorny (TS)	1905		100t, 30.8x5.0x1.7m, 2b,1vte, 660hp, 16kts, 31p; 1x1-37/23, MS
	Minrep	1	3	Zapal	1912		150t, 45.0x6.1x1.9m, 2b,2vde, 280hp, 11kts, 30p; 1x1-57/50, MS, 50m
	Kapsyul	2	4	Kapsyul	1916		271t, 53.0x6.6x1.2m, 2b,2vte, 650hp, 9kts, 38p; 1x1-75/50, MS
			5	Gruz	1916		
	Udarnik	2	6	Udarnik	1917		220t, 43.6x6.1x1.7m, 2b,2vte, 400hp, 11kts, 35p; 1x1-75/50, 1x1-47/43, MS
7			Klyuz	1917			
Dzhalita	1	8	No11	1926		470t, 40.5x6.2x2.9m, 2b,2vte, 300hp, 8kts, 39p; 1x1-45/46, MS	
AMS	-	6	1	Zmey	1914		200t
			2	Nevod	1915		310t; 1x1-75/50
			3	Piksha	1880		128t
			4	Yakor	1915		310t; 2x1-75/50
			5	No24	1924		500t
			6	Sofiya	1883		420t

## BOARD GUARD SHIPS

	Barsuk	2	1	Atarbekov	1916		202t, 30.5x5.8x2.7m, 1b,1vte, 350hp, 11kts, 46p; 2x1-75/50, 1x1-37/23
--	--------	---	---	-----------	------	--	---

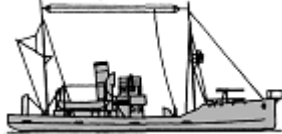
PC			2	Mogilevskiy	1916		
	T.13	1	5	PS-1	1916		580t, 43.2x7.2x3.5m, 1b,1vte, 500hp, 11kts, 35p; 1x1-57/50, MS, 30m
APC	-	2	1	Sovetskiy Azerbaydzhan	1893		1091t, 74.8x9.6x4.0m, 640hp, 14kts; 2x1-130/55
			2	Vorovskiy	1901		3315t, 96.6x12.2x5.5m, 6000hp, 18kts; 2x1-120/45
YP	K-105	3	1 - 3	K-105, 108, 240	1928	No picture	29t, 22.6x3.8x1.5m, 300hp, 12kts, 13p; 1x1-45/46
	K-1	5	4 - 8	K-391 - 395	1928	No picture	15t, 12.9x2.9x1.4m, 100hp, 8kts, 9p

[home](#)

[World navies yesterday](#)

[1930](#)

# Spain 01 January 1930

## CAPITAL SHIPS

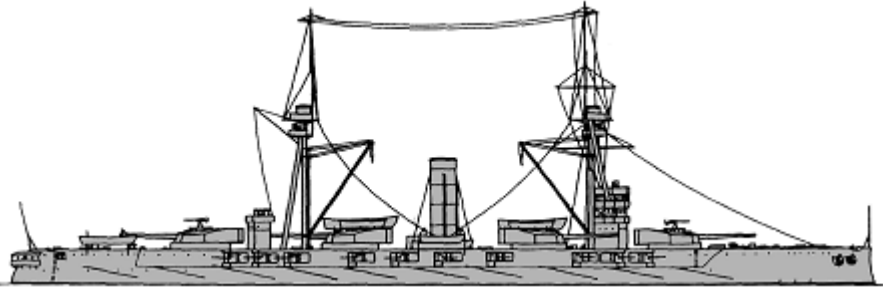
BB	España	1	Alfonso XIII	1915		<p>15700t, 139.9x24.0x7.8m, 12b,4t, 15500hp, 19.5kts, 854p; 230belt, 90deck, 234turrets, 250CT; 4x2-305/50, 20x1-102/50, 2x1-76/34</p>
		2	Jaime I	1921		

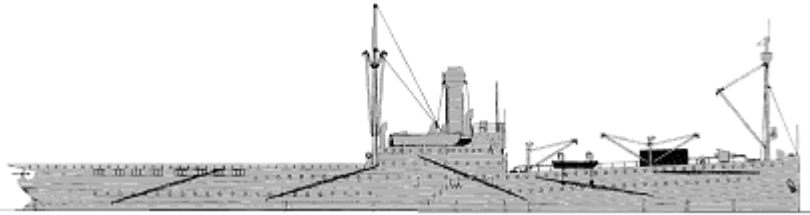

## AIRCRAFT CARRYING SHIPS

AV	Dédalo	1	1	Dédalo	1901		<p>9900t, 128.0x16.8x7.4m, 3b,1vte, 2200hp, 10kts, 398p; 2x1-105/35, 2x1-57/42, 20seaplanes (M.18), 1airship (SCA), 2balloons</p>
----	--------	---	---	--------	------	--	---

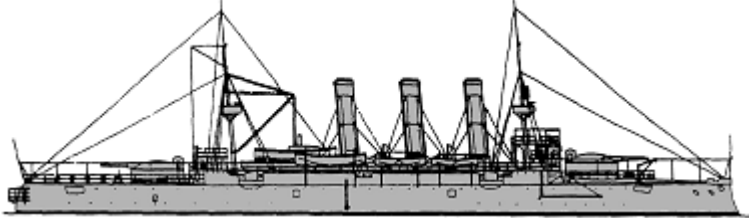

## CRUISERS

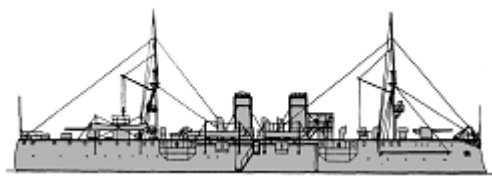
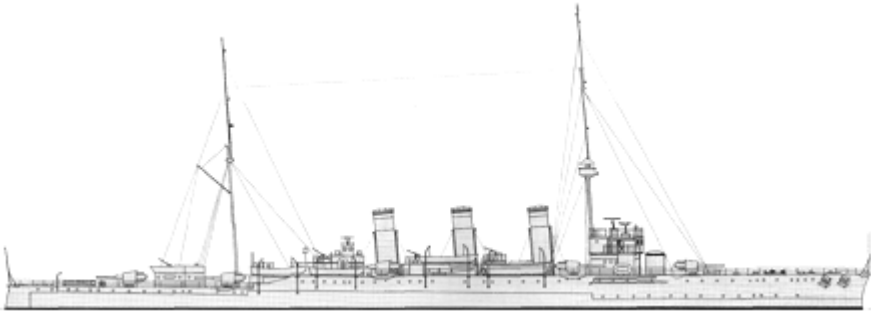
CA	Carlos V	1	1	Carlos V	1897		<p>10100t, 115.8x20.4x7.6m, 12b,2vte, 18500hp, 20kts, 583p; 50belt, 165deck, 100turrets, 300CT; 2x1-280/35, 4x1-105/32, 8x1-12.7, 2-356TT</p>
	Río de La Plata	1	1	Río de La Plata	1900		<p>1950t, 76.3x10.8x4.4m, 4b,2vte, 7100hp, 20kts, 213p; steel; 20slopes, 15deck, 120CT; 6x1-105/32, 20m</p>

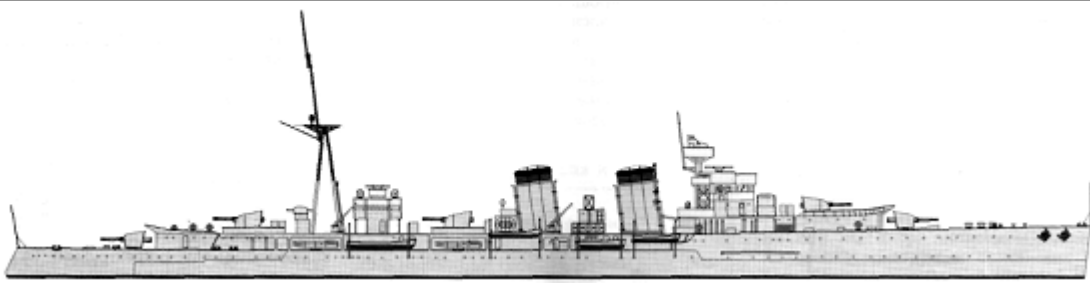

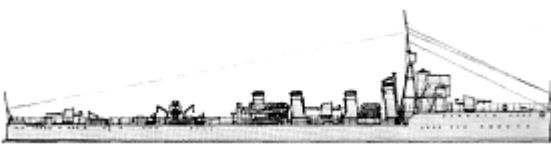

CL							
	Reina Victoria Eugenia	1	2	Reina Victoria Eugenia	1923		6450t, 140.8x15.2x4.8m, 12b,2t, 25500hp, 25kts, 404p; 50belt, 38deck, 152shields, 152CT; 9x1-152/50, 1x1-76/19, 4x1-47/50, 2x2-533TT
	Méndez Núñez	2	3	Méndez Núñez	1924		6045t, 140.8x14.1x4.4m, 12b,4gt, 45000hp, 29kts, 343p; 76belt, 25deck, 150CT; 6x1-152/50, 1x1-76/19, 4x1-47/50, 4x3-533TT
			4	Blas de Lezo	1925		
Príncipe Alfonso	2	5	Príncipe Alfonso	1925		9237t, 176.6x16.5x5.0m, 8b,4gt, 80000hp, 33kts, 564p; 76belt, 50deck, 13shields, 150CT; (3x2+2x1)-152/50, 4x1-102/45, 2x1-47/50, 4x3-533TT	
6		Almirante Cervera	1927				

### TORPEDO SHIPS

DD	Audaz	1	1	Proserpina	1898		457t, 69.8x6.9x1.8m, 4b,2vte, 7500hp, 30kts, 67p; 2x1-75/43, 2x1-57/42, 2x1-37/27, 2x1-356TT, 20m
	Bustamante	3	2	Bustamante	1914		530t, 67.4x6.7x1.7m, 3b,3t, 6250hp, 28kts, 70p; 5x1-57/40, 2x2-450TT(2,3), 2x2-381TT(4), 20m
			3	Villaamil	1916		
			4	Cadarso	1917		
	Alsedo	3	5	Alsedo	1924		1337t, 86.8x8.2x4.5m, 4b,2gt, 33000hp, 34kts, 86p; 3x1-102/45, 2x1-47/50, 2x2-450TT, 1DCR, 60m
			6	Velasco	1924		
			7	Lazaga	1925		
	Churucca	3	8	Sánchez Barcáiztegui	1928		2087t, 102.0x9.7x3.2m, 4b,2gt, 42000hp, 36kts, 190p; 5x1-120/45, 1x1-76/45, 2x3-533TT, 2DCR
			9	Almirante Ferrándiz	1929		

							
		10	José Luis Díez	1929			
TB	T-1	22	1	T-1	1912		190t, 52.3x5.0x1.5m, 2b,3(1-7)-2(8-22)t, 3750hp, 26kts, 31p; 3x1-47/50, (1x2+1x1)-450TT
			2	T-2	1912		
			3	T-3	1912		
			4	T-4	1913		
			5	T-5	1914		
			6	T-6	1915		
			7	T-7	1915		
			8	T-8	1915		
			9	T-9	1915		
			10	T-10	1915		
			11	T-11	1916		
			12	T-12	1916		
			13	T-13	1916		
			14	T-14	1916		
			15	T-15	1917		
			16	T-16	1917		
			17	T-17	1917		
			18	T-18	1918		
			19	T-19	1920		
			20	T-20	1920		
			21	T-21	1921		
			22	T-22	1921		



### SUBMARINES

	Isaac Peral	1	1	Isaac Peral	1917		488/750t, 60.1x5.8x3.4m, 2d/em, 1200/680hp, 15/10kts, 28p, 50m; 1x1-76/23, 4-450TT
A1		3	2	A1 Narciso Monturiol	1917		262/319t, 45.6x4.2x3.1m, 2d/em, 700/500hp, 12.8/8kts, 17p, 45m; 2-450TT
			3	A2 Cosme García	1917		
			4	A3	1917		
SS	B1	6	5	B1	1922		556/740t, 64.2x5.6x3.4m, 2d/em, 1400/420hp, 16.2/10.5kts, 28p, 60m; 1x1-76/45, 4-450TT
			6	B2	1922		
			7	B3	1922		
			8	B4	1923		
			9	B5	1925		
			10	B6	1926		

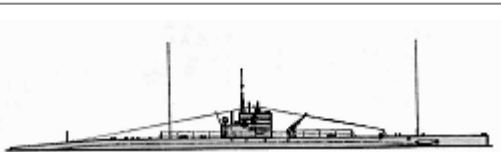

C1	4	11	C1	1928		915/1143t, 75.3x6.3x4.1m, 2d/em, 2000/750hp, 16.5/8.5kts, 40p, 90m; 1x1-76/45(11,12), 1x1-76/50(13,14), 6-533TT
		12	C2	1928		
		13	C3	1929		
		14	C4	1929		

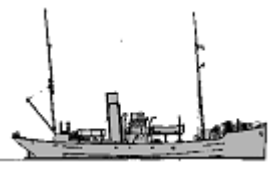
## ESCORTS

PC	Delfin	1	1	Gaviota	1911	No picture	158t, 11kts; 1x1-57/42
	Uad Lucus	5	2	Uad Lucus	1917		547t, 40.8x7.2x2.8m, 1b,1vte, 480hp, 10.5kts, 39p; 1x1-76/50
			3	Uad Martin	1917		
			4	Uad Muluya	1917		
			5	Uad Ras	1918		
			6	Uad Targa	1918		
	Uad Kert	3	7	Uad Kert	1917		665t, 45.1x7.2x2.8m, 1b,1vte, 600hp, 11kts, 45p; 1x1-76/50(7,9), 2x1-76/50(8), 1x1-47/50(9)
			8	Arcila	1918		
			9	Xauen	1918		
	Alcázar	3	10	Alcázar	1919		440t, 41.0x7.3x3.2m, 1b,1vte, 425hp, 11kts, 41p; 1x1-76/50, 1x1-57/42(12), 2x1-47/50(10)
			11	Larache	1919		
			12	Tetuán	1919		
FPV	Condestable Zaragoza	8	1	Condestable Zaragoza	1919	No picture	150t, 24.5x6.0x2.7m, 1b,1vte, 300hp, 11kts, 11p; 1x1-42/42
			2	Cabo de Infantería Marina Garcíolo	1919		
			3	Contramaestre Castelló	1919		
			4	Maquinista Macías	1919		
			5	Torpedista Hernández	1919		
			6	Marinero Cante	1919		
			7	Fogonero Bañobre	1919		
			8	Marinero Jarana	1919		

## OTHER FIGHTING SHIPS

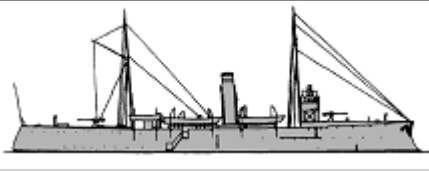
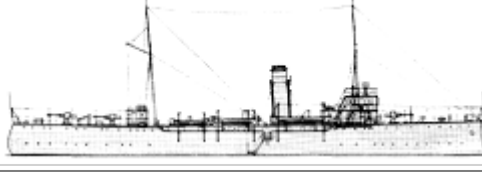
PG	Mac-Mahón	1	1	Mac-Mahón	1888	No picture	115t, 27.6x4.9x1.8m, 2b,2vte, 150hp, 9kts, 15p; 2x1-42/42, 1x5-37/20
	Recalde	4	2	Recalde	1911		811t, 65.5x9.1x3.0m, 2b,2vte, 1200hp, 13.5kts, 130p; 4x1-76/50
			3	Laya	1911		
			4	Bonifaz	1911		
			5	Lauria	1912		
	Antonio Cánovas del Castillo	3	6	Antonio Cánovas del Castillo	1923		1335t, 77.3x10.2x3.4m, 2b,2vte, 1700hp, 15kts, 132p; 4x1-102/45, 2x1-47/50
			7	José Canalejas	1924		
			8	Eduardo Dato	1925		
PR	Cabo Fradera	1	1	Cabo Fradera	1928		45t, 22.8x4.4x1.2m, 2pe, 121hp, 10.7kts, 16p; 1x1-42/42



### COASTAL FORCES

YP	M1	4	1-4	M1, 3, 5, 6	1918		37t, 24.4x3.7x1.2m, 2pe, 440hp, 19kts, 8p; 1x1-47/50, 2DCR, MS
YP(Ta)	C.I	21	1-21	C.I-XXI	1922-1925	No picture	36t, 22.8x4.0x1.4m, 2d, 180hp, 12kts, 6p
	I1	6	22	I1	1923	No picture	128t, 33.5x2.6x1.8m, 2d, 600hp, 13kts
			23	I2	1923		
			24	I3	1923		
			25	I4	1923		
			26	I5	1923		
			27	I6	1923		

### AMPHIBIOUS SHIPS AND CRAFTS

LCT	K1	22	1	K2	1915		160t, 32.2x6.4x1.5m, 1sd, 60hp, 8kts, 15p; 300troops or 150t cargo
			2	K3	1915		
			3	K4	1915		
			4	K5	1915		
			5	K6	1915		
			6	K7	1915		
			7	K8	1915		
			8	K9	1915		
			9	K10	1915		
			10	K12	1915		
			11	K13	1915		
			12	K14	1915		
			13	K15	1915		
			14	K28	1915		
			15	K17			
			16	K18			
			17	K19			
			18	K20			
			19	K23			
			20	K24			
			21	K25			
			22	K26			

### MINE WARFARE SHIPS AND CRAFTS

ML	Anteo	1	1	Anteo	1903	No picture	342t, 40.0x6.6x2.1m, 1b,1vte, 650hp, 11kts; 40m, MS
----	-------	---	---	-------	------	------------	---

© Ivan Gogin, 2011-14

[home](#)[World navies yesterday](#)[1930](#)

# SWEDEN 01 January 1930

## CAPITAL SHIPS

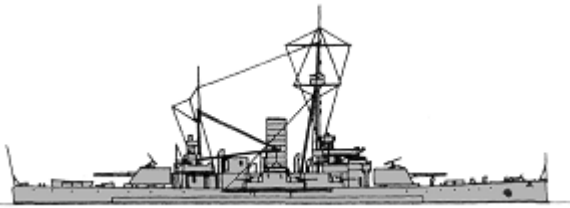
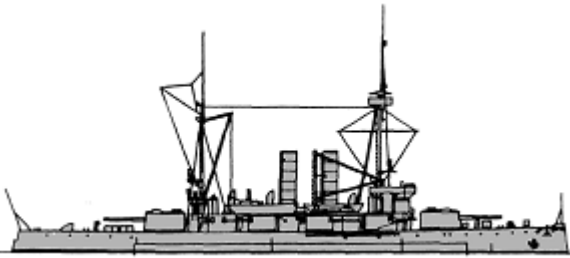
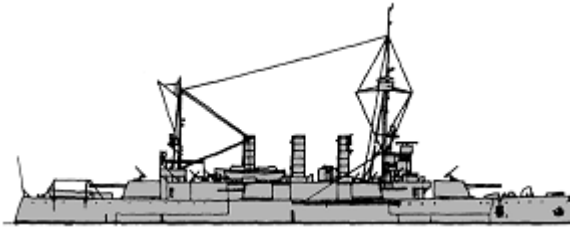
BC	Oden	1	Oden	1897		3715(1)-3720(2)t, 86.3x14.8x5.3m, 6b, 2vte, 5350hp, 16.5kts, 254p; s(1)-h(2): 243(1)-240(2)belt, 49deck, 200(1)-190(2)turrets, 247(1)-190(2)CT; 2x1-254/42, 4x1-120/45(1), 6x1-120/45(2), 10x1-57/55	
		2	Thor	1899			
	Äran	4	3	Äran	1902		3735t, 89.7x15.0x5.0m, 8b, 2vte, 6500hp, 17kts, 275p; 175belt, 48deck, 190turrets, 200CT; 2x1-210/44, 6x1-152/44, 10x1-57/55, 2x1-37/35, 2-450TT
			4	Wasa	1902		
			5	Tapperheten	1903		
			6	Manligheten	1904		
	Oscar II	1	7	Oscar II	1907		4584t, 95.6x15.4x5.5m, 10b, 2vte, 9400hp, 18kts, 331p; 150belt, 50deck, 190turrets, 157CT; 2x1-210/44, 4x2-152/50, 10x1-57/55, 3x1-37/35, 2-450TT
	9	Drottning Victoria	1921				
	10	Gustaf V	1922				





## AIRCRAFT CARRYING SHIPS

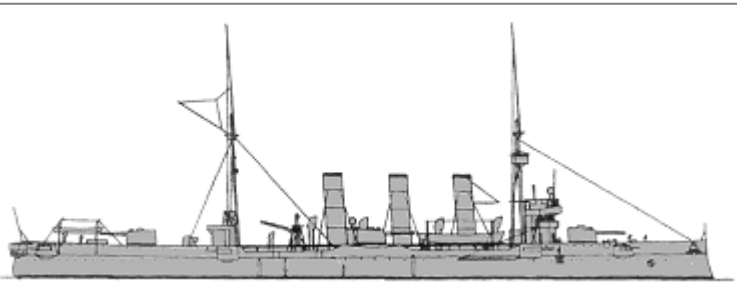
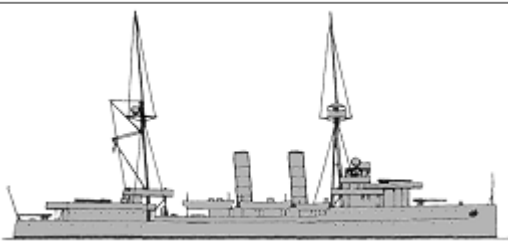

AV	Dristigheten	1	1	Dristigheten	1901		3600t, 89.0x14.8x5.2m, 8b, 2vte, 5600hp, 16.8kts, 275p; h: 200belt, 50deck, 247CT; 4x1-75/50, 3seaplanes (3 Fairey IIID)
----	--------------	---	---	--------------	------	--	--

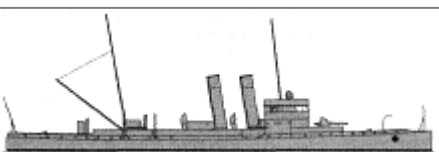
## CRUISERS

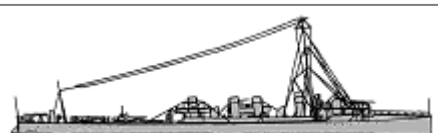



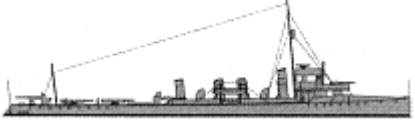

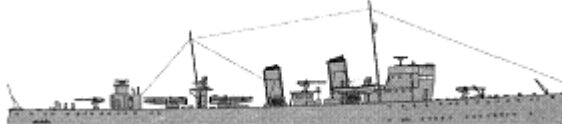

CA	Fylgia	1	1	Fylgia	1907		4734t, 115.1x14.8x6.3m, 12b, 2vte, 12000hp, 21.5kts, 320p; 100belt, 35deck, 125turrets, 100CT; 4x2-152/50, 14x1-57/55, 2-450TT
CM	Clas Fleming	1	1	Clas Fleming	1914		1800t, 80.2x10.4x4.3m, 8b, 2t, 6500hp, 20kts, 160p; 25deck, 75CT; 4x1-120/50, 100mines

## TORPEDO SHIPS

PGT	Örnen	1	Örnen	1897		814-844t, 67.7(1, 2)-70.7(3)x8.2(1, 2)-8.3(3)x3.1(1, 2)-3.0(3)m, 8b, 2vte, 4000(1, 2)-4500(3)hp, 20kts, 113p; 19deck; 2x1-120/45, 4x1-57/55, 1-380TT, 1seaplane(2) (1 Fairey IIID)	
		2	Jacob Bagge	1898			
		3	Psilander	1900			
DD	Magne	1	1	Magne	1905		460t, 65.8x6.3x2.5m, 4b, 2vte, 7200hp, 30kts, 67p; 6x1-57/55, 2x1-450TT
	Wale	1	2	Wale	1908		461t, 66.1x6.3x2.8m, 4b, 2vte, 7665hp, 30kts, 54p; 2x1-75/50, 4x1-57/55, 2x2-450TT
	Ragnar	3	3	Vidar	1910		460t, 66.1x6.3x2.7m, 4b, 2vte, 7200hp, 30kts, 54p; 4x1-75/50, 2x2-450TT
			4	Ragnar	1909		
			5	Sigurd	1909		
		6	Hugin	1911			



	2	7	Munin	1913		500t, 66.3x6.5x3.5m, 4b, 2t, 10000hp, 33kts, 72p; 4x1-75/50, 2x2-450TT
		8	Wrangel	1918		498t, 72.0x6.9x2.8m, 4b, 2gt, 13000hp, 34kts, 81p; 4x1-75/50, (2x2+2x1)-450TT
			9	Wachtmeister		
Ehrensköld	2	10	Ehrensköld	1927		1160t, 91.4x8.9x3.8m, 3b, 2gt, 24000hp, 36kts, 120p; 3x1-120/45, 2x1-40/39, 2x3-533TT, 2DCT, 2DCR, 20mines
		11	Nordenskjöld	1927		

## SUBMARINES

SS	Motala	1	1	N:r3	1909		138/230t, 26.8x3.6x3.0m, 1d/em, 420/200hp, 8.8/6.6kts, 12p, 30m; 1-450TT
	Svärdfisken	2	2	Svärdfisken	1915		252/370t, 45.5x4.2x3.0m, 2d/em, 1000/300hp, 14.2/8.5kts, 21p, 30m; 1x1-57/55, 2-450TT
			3	Tumlaren	1915		
	Delfinen	1	4	Delfinen	1915		260/370t, 42.5x4.3x3.0m, 2d/em, 1000/300hp, 13.6/9.4kts, 21p, 30m; 1x1-37/39, 2-450TT
	Laxen	2	5	Laxen	1915		140/170t, 26.8x3.6x3.0m, 2d/em, 700/200hp, 8.8/6.6kts, 10p, 30m; 1-450TT
			6	Gäddan	1915		
	Abborren	2	7	Abborren	1917		174/310t, 31.0x3.6x3.1m, 2d/em, 920/280hp, 9.5/7.4kts, 14p, 30m; 2-450TT
			8	Braxen	1917		
	Hajen	3	9	Hajen	1920		422/600t, 54.0x5.2x3.5m, 2d/em, 2000/700hp, 15.5/9kts, 30p, 30m; 1x1-75/50, 4-450TT
			10	Sälen	1920		
			11	Valrossen	1920		
	Bävern	3	12	Bävern	1921		472/650t, 57.0x5.8x3.0m, 2d/em, 2100/520hp, 15.2/8.2kts, 28p, 30m; 1x1-57/55, 4-450TT
			13	Illern	1921		
			14	Uttern	1921		
	Valen	1	15	Valen	1925		548/730t, 57.1x7.1x3.1m, 2d/em, 1340/700hp, 14.8/7.4kts, 31p, 60m; 1x1-75/50, 4-450TT, 20mines
	Draken	2	16	Draken	1929		750/850t, 66.2x6.4x3.3m, 2d/em, 1920/1000hp, 13.8/8.3kts, 35p, 60m; 1x1-105/41, 4-533TT
			17	Gripen	1929		

## ESCORTS

	Komet	11	1	V27	1898		120t, 39.8x4.8x2.5m, 1b, 1vc, 1300hp, 23kts, 18p; 2x1-37/39, MS
			2	V28	1899		
			3	V29	1899		
			4	V30	1900		
			5	V31	1900		
			6	V32	1900		

PC							106t, 40.2x4.4x2.6m, 2b, 1vte, 2000hp, 26kts, 25p; 2x1-57/55, MS
			7	V33	1902		
			8	V34	1902		
			9	V35	1903		
			10	V36	1903		
	11	V37	1904				
	Plejad	17	12	V38	1905		
			13	V39	1908		
			14	V40	1908		
			15	V41	1908		
			16	V42	1908		
			17	V43	1909		
			18	V44	1909		
			19	V45	1909		
			20	V46	1909		
			21	V47	1909		
			22	V48	1910		
			23	V49	1910		
			24	V50	1910		
			25	V51	1909		
			26	V52	1909		
			27	V53	1910		
			28	V54	1910		

## COASTAL FORCES

PT	Mtb3	2	1, 2	Mtb3, 4	1925		12.5t, 16.2x3.4x1.1m, 2pe, 750hp, 40kts, 7p; 2-450TT, 4DC
----	------	---	---------	---------	------	---	---

## MINE WARFARE

ML	Mul3	1	1	Mul3	1879	No picture	190t, 6.5kts; mines
	Mul5	4	2	Mul5	1904	No picture	120t, 7.5kts; mines
			3	Mul6	1904		
			4	Mul7	1904		
			5	Mul8	1905		
Mul9	1	6	Mul9	1912	No picture	120t, 9.1kts; mines	
MS	Sökaren	3	1	Sökaren	1918	No picture	266t, 27.8x6.8x3.0m, 1b, 1vte, 465hp, 10kts, 17p; 1x1-57/21, mines, MS
			2	Sveparen	1918		
			3	Sprängaren	1918		

© Ivan Gogin, 2010-14



[home](#)[World navies yesterday](#)[1930](#)

## Turkey 01 January 1930

### CAPITAL SHIPS

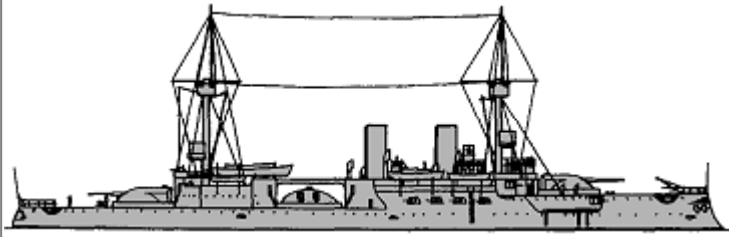
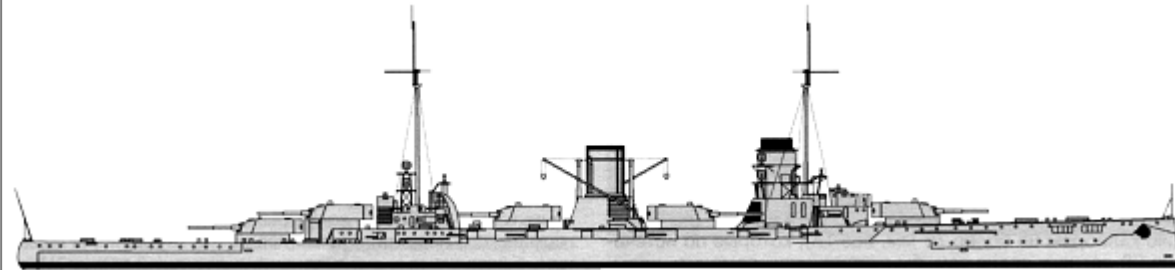

BB	Torgud Reis	1	1	Torgud Reis (TS)	1894		10670t, 115.7x19.5x7.6m, 12b,2vte, 10200hp, 16.5kts, 600p; Harvey- 400belt, 60deck, 300barbettes, 300CT; 2x2-280/40, 1x2-280/35, 2x1-88/30, 2-450TT
CB	Yavuz Sultan Selim	1	1	Yavuz Sultan Selim	1912		25400t, 186.6x29.5x8.7m, 24b,4t, 52000hp, 25.5kts, 1053p; 270belt, 50deck, 230turrets, 350CT; 5x2-283/47, 10x1-150/45, 16x1-88/45, 4-500TT

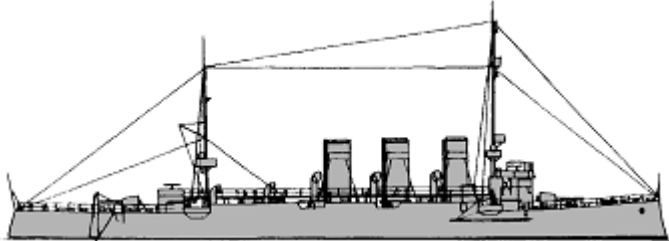
### CRUISERS

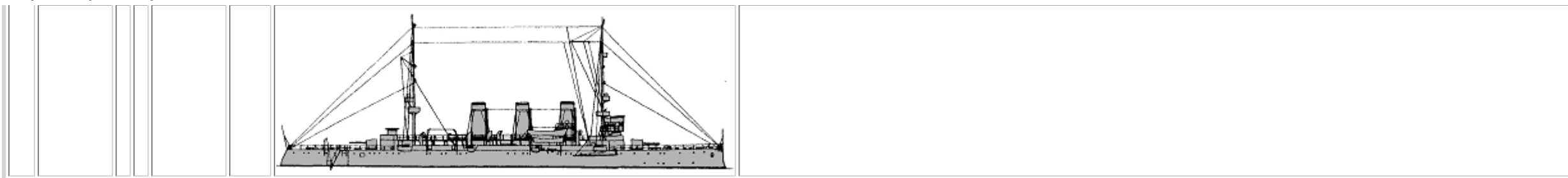
CL	Mecidiye	1	1	Mecidiye	1903		3967t, 102.4x12.8x4.8m, 16b,2vqe, 12500hp, 22kts, 312p; 38deck, 102slopes; 4x1-130/55, 4x1-76/50, 2-450TT
	Hamidiye	1	2	Hamidiye	1904		

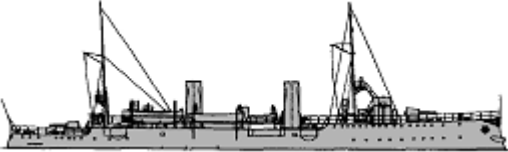

## TORPEDO SHIPS

PGT	Peyk-i Şevket	2	1	Peyk	1907		775t, 80.1ppx8.4x4.6m, 4b,2vte, 5100hp, 21kts, 105p; 2x1-105/40, 6x1-57/40, 2x1-37/50, (1+2x1)-450TT
			2	Berk	1907		
DD	Samsun	3	1	Samsun	1907		284t, 58.2x6.3x2.8m, 2b,2vte, 5950hp, 28kts, 23p; 1x1-65/50, 6x1-47/50, 2x1-450TT
			2	Taşoz	1907		
			3	Basra	1907		
TB	Akhisar	1	1	Akhisar	1904		165t, 51.0x5.7x1.4m, 2b,2vte, 2400hp, 24kts, 30p; 1x1-47/45, 2x1-37/23, 1x1-450TT

## SUBMARINES

SS	İnönü	2	1	Birinci İnönü	1928		519/674t, 58.7x5.8x3.8m, 2d/em, 1100/700hp, 13.5/8.5kts, 44p, 50m; 1x1-75/55, 6-450TT
			2	İkinci İnönü	1928		

## OTHER FIGHTING SHIPS

PG	Aydın Reis	2	1	Sakiz	1914		503t, 54.5x8.2x2.4m, 3b,2vte, 1025hp, 14kts, 75p; 2x1-47/50
			2	Bürak Reis	1914		
PG	İsa Reis	3	3	İsa Reis	1914		413t, 47.0x7.9x1.3m, 3b,2vte, 850hp, 14kts, 60p; 2x1-75/50, 2x1-47/50
			4	Kemal Reis	1914		
			5	Hizir Reis	1914		
ADV	-	1	1	Galata	1896		120t

## COASTAL FORCES

YP	No1	9	1-9	No11, 14, 15, 17, 18, 20-23	1914		20t, 18.3ppx3.3x1.6m, 2pe(1), 70hp, 11.9kts, 6p; 1x1-37/37
----	-----	---	-----	-----------------------------	------	---	--

## MINE WARFARE SHIPS

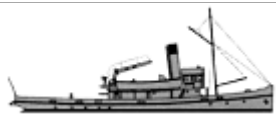
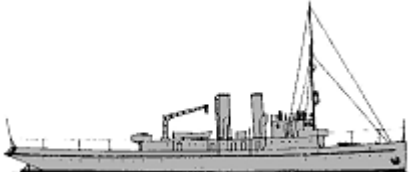
ML	Nusret	1	1	Nusret	1913		365t, 40.2ppx7.6x3.4m, 2b,2vte, 1200hp, 15kts; 2x1-57/40, 40m
AML	-	1	1	Uyanik	1886		616brt; 1x1-75/35, 50m

© Ivan Gogin, 2011-15

[home](#)



[World navies yesterday](#)

[1930](#)

# UNITED KINGDOM 01 January 1930

*IN SERVICE: 16 battleships, 4 battlecruisers, 4 monitors, 4 fleet aircraft carriers, 2 light aircraft carriers, 2 seaplane tenders, 13 heavy cruisers, 1 protected cruiser, 35 light cruisers, 1 cruiser-minelayer, 21 destroyer leaders, 127 destroyers, 55 submarines, 28 sloops, 5 patrol ships, 1 patrol craft, 19 river gunboats, 9 motor torpedo boats, 6 small landing ships, 2 small landing barges, 2 landing crafts, 4 minelayers, 2 auxiliary minelayers, 28 minesweepers, 15 minesweeping trawlers, 29 minesweeping drifters*

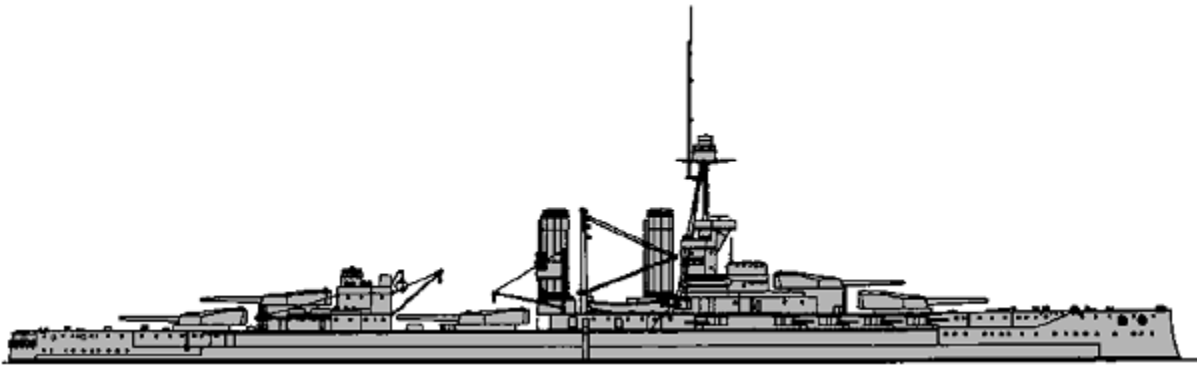
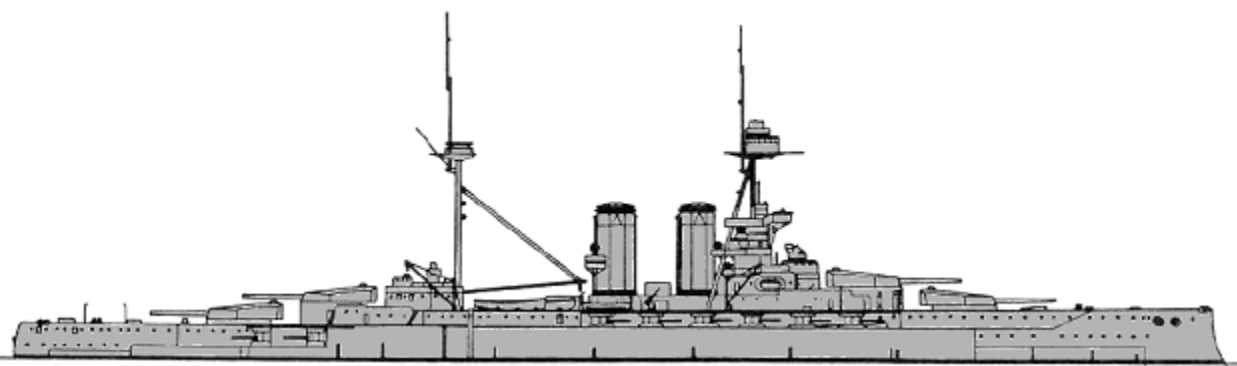
## CAPITAL SHIPS AND MONITORS

BB	Iron Duke	1	Iron Duke	1914		30380t, 189.8x27.4x9.0m, 18, 4t, 29000hp, 21.3kts, 1022p; 305belt, 280turrets, 89deck, 305CT; 5x2-343/45, 12x1-152/45, 2x1-76/45, 4x1-47/40, 4-533TT
		2	Marlborough	1914		
		3	Benbow	1914		
		4	Emperor of India	1914		
	Queen Elizabeth	5	Queen Elizabeth	1915		35710(5, 6, 9)-31500(7, 8)t, 196.8x31.7(5, 6, 9)-27.6(7, 8)x8.8m, 24boilers, 4turbines, 56000hp, 23.5(5, 6, 9)-24(7, 8)kts, 951p; 330belt, 330turrets, 102deck, 280CT; 4x2-381/42, 12x1-152/45, 4x1-102/45, 4x1-47/40, 4-533TT
		6	Warspite	1915		
		7	Barham	1915		
		8	Valiant	1916		
		9	Malaya	1916		
	Revenge	10	Revenge	1916		32526(10, 13)-32474(11)-32100(12)-33500(14)t, 190.3x30.9(10, 13)-31.0(11)-31.1(12, 14)x8.3(10, 13)-8.7(11, 12)-8.4(14)m, 18b, 4gt, 40000hp, 22(10-13)-21.5(14)kts, 997p; 330belt, 330turrets, 102deck, 280CT; 4x2-
		11	Royal Sovereign	1916		
		12	Royal Oak	1916		
		13	Resolution	1916		

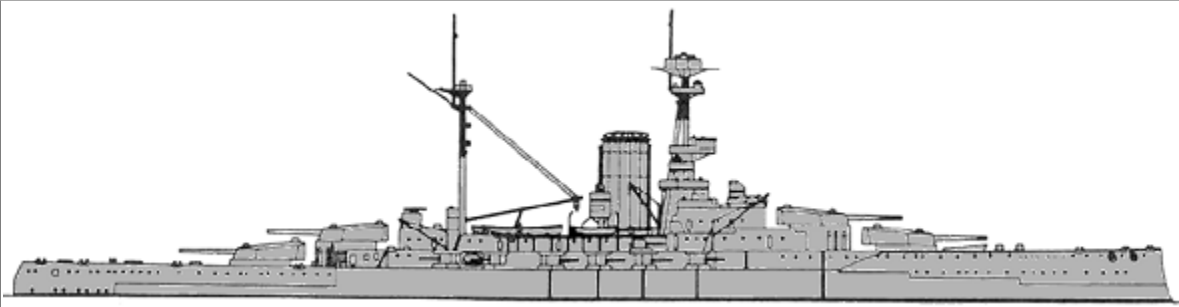
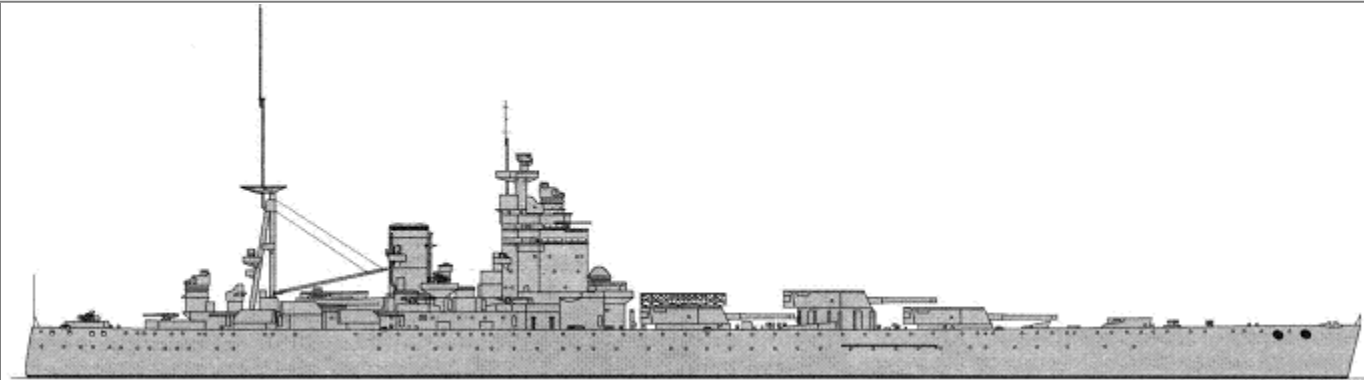
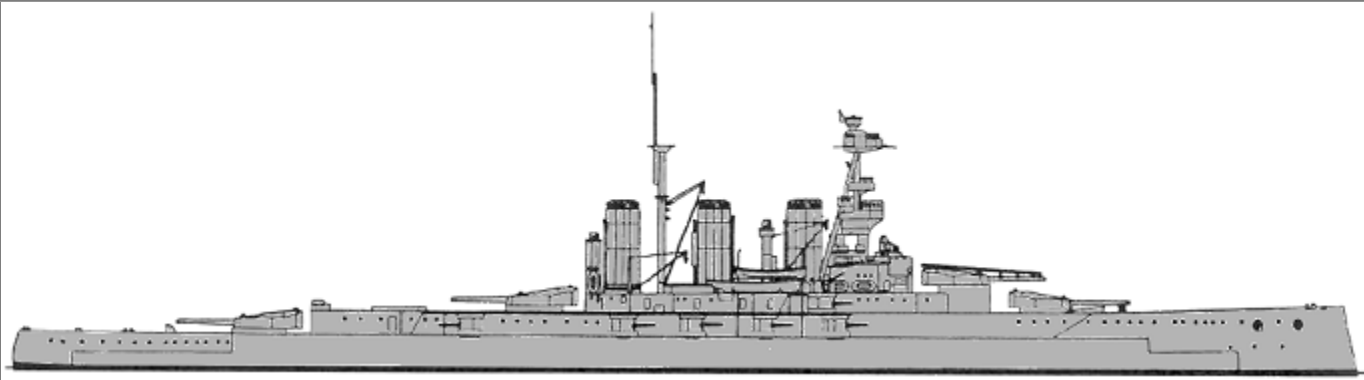
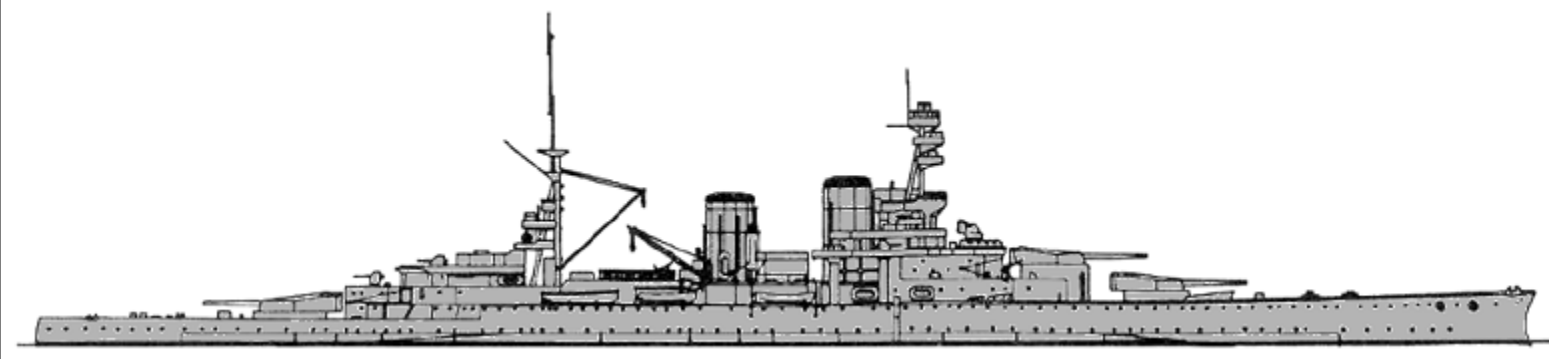
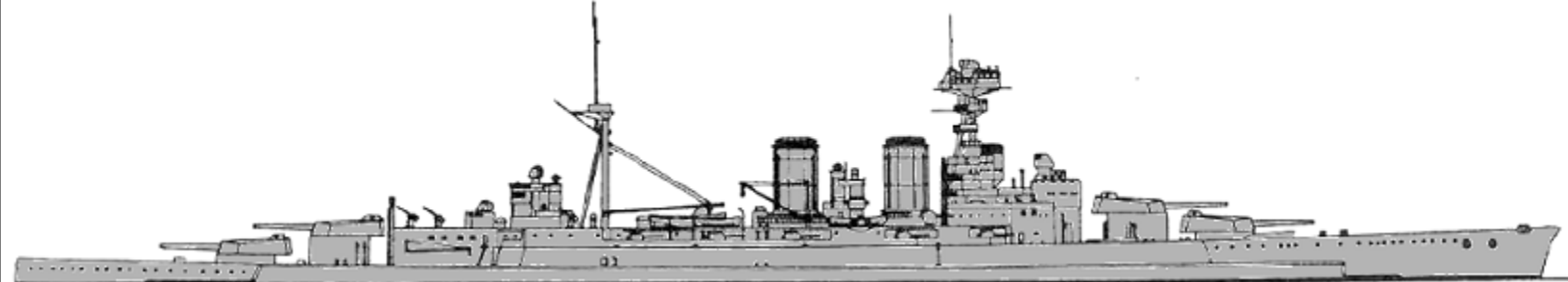
							
		14	Ramillies	1917		381/42, 12x1-152/45, 4x1-102/45, 4x1-47/40, 4-533TT	
Nelson	2	15	Nelson	1927		41250t, 216.4x32.3x10.2m, 8b, 2gt, 45000hp, 23kts, 1314p; 356belt, 406turrets, 159deck, 356CT; 3x3-406/45, 6x2-152/50, 6x1-120/40, 8x1-40/39, 4x1-47/40, 2-622TT	
		16	Rodney	1927			
BC	Tiger	1	1	Tiger	1914		35710t, 214.6x27.6x8.7m, 39b, 4gt, 85000hp, 28kts, 1121p; 229belt, 229turrets, 76deck, 254CT; 4x2-343/45, 12x1-152/45, 4x1-102/45, 4x1-47/40, 4-533TT
		2	2	Renown	1916		37150(2)-37490(3)t, 242.0x31.2(2)-30.8(3)x9.5(2)-9.6(3)m, 42b, 4t, 112000hp, 30kts, 967p; 229belt, 229turrets, 102(2)-76(3)deck, 254CT; 3x2-381/42, (5x3+4x1)-102/45, (4x2+2)-533TT(3)
			3	Repulse	1916		
	Hood	1	4	Hood	1920		46680t, 262.1x31.7x8.7m, 24b, 4gt, 144000hp, 31kts, 1477p; 305belt, 381turrets, 76deck, 280CT; 4x2-381/42, 12x1-140/50, 4x1-102/45, 4x1-47/40, 6-533TT

MON	Abercrombie	1	1	Roberts	1915		6150t, 102.0x27.4x3.1m, 2b, 2vte, 1800hp, 6kts, 198p; 102belt, 254turret, 51deck; 1x2-356/45, 1x1-152/40, 2x1-76/50, 1x1-76/45, 1x1-47/50, 2x1-40/39
	Marshal Ney	1	2	Marshal Sout	1915		6900t, 108.4x27.5x3.2m, 2diesels, 1500hp, 6kts, 187p; 102belt, 330turret, 102deck, 152CT; 1x2-381/42, 8x1-102/45, 2x1-76/50, 1x1-76/45, 1x1-47/50, 2x1-40/39
	Erebus	2	3	Erebus	1916		8450t, 123.4x26.9x3.6m, 4b, 2vte, 6000hp, 12kts, 204p; 102belt, 330turret, 102deck; 1x2-381/42, 8x1-102/45, 2x1-76/45, 2x1-76/40, 2x1-40/39
4			Terror	1916			

### AIRCRAFT CARRYING SHIPS

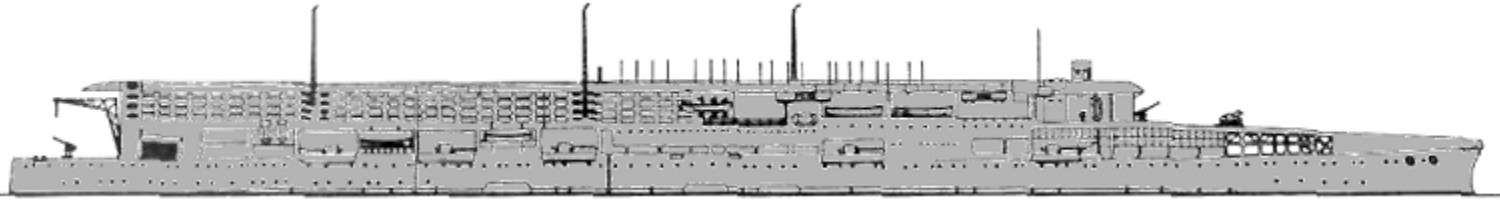
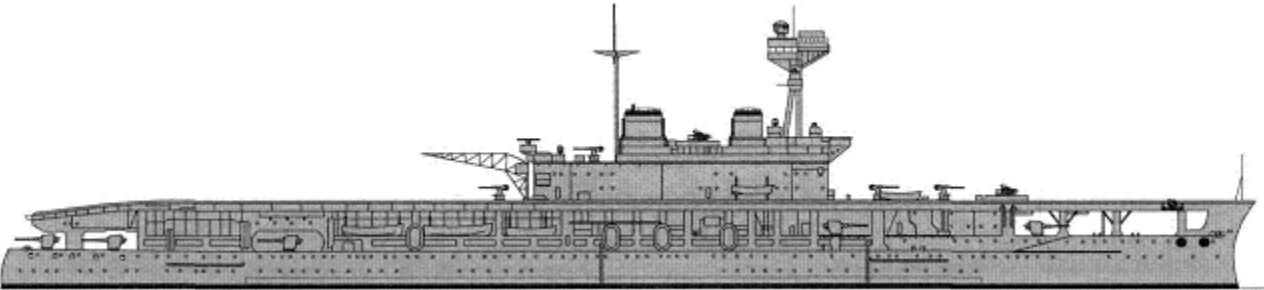
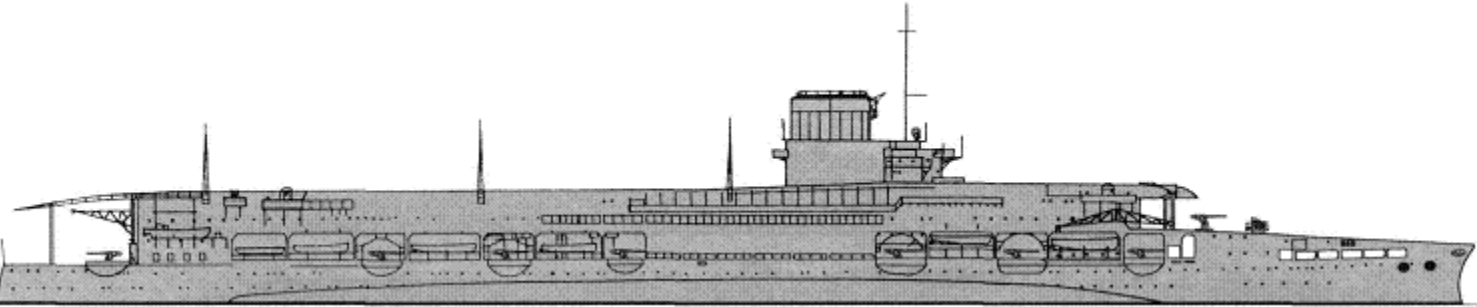

CV	Furious	1	1	Furious	1917		27165t, 239.7x27.9x8.6m, 18b, 4gt, 90000hp, 30kts, 1218p; 76belt, 76deck; 10x1-140/50, 2x1-102/45, 4x1-47/40, 4x1-40/39, 36aircraft (6 Flycatcher, 12 Dart, 18 Fairey III F)
	Eagle	1	2	Eagle	1923		26800t, 203.5x32.0x8.1m, 32b, 4gt, 50000hp, 22.5kts, 950p; 114belt, 76shields, 38deck; 9x1-152/50, 5x1-102/45, 2x1-40/39, 25aircraft (9 Flycatcher, 12 Fairey III F)
	Courageous	2	3	Courageous	1917		27560(3)-27400(4)t, 239.8x27.9x8.5m, 18b, 4gt, 90000hp, 1216p; 76belt, 76deck; 16x1-120/40, 4x1-47/40, 4x1-40/39, 48 aircraft (12 Flycatcher, 12 Ripon or Dart, 12 Fairey III F)
4			Glorious	1917			
							15750t, 172.5x24.2x6.4m, 12b, 4gt, 20000hp,

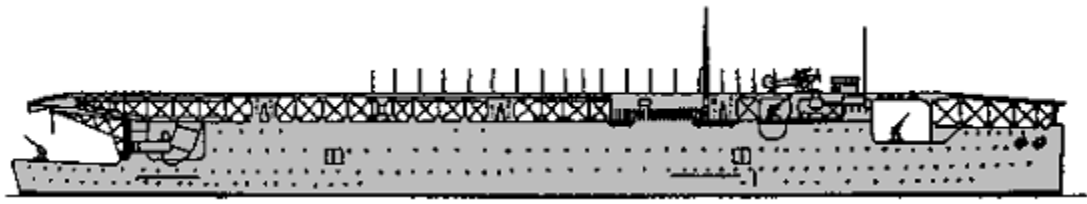
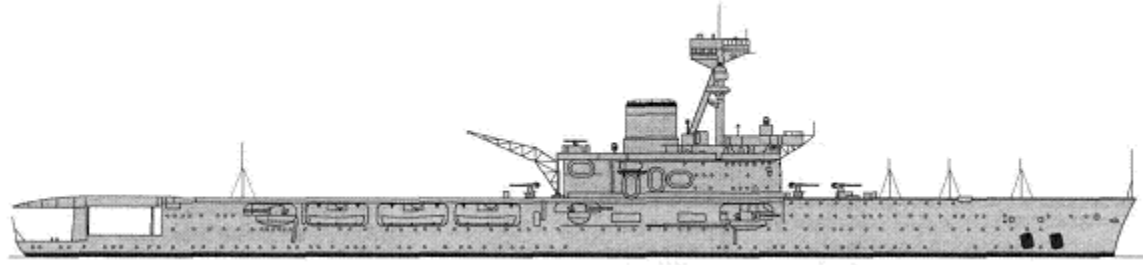
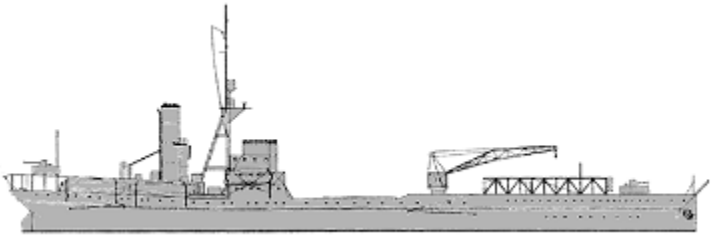

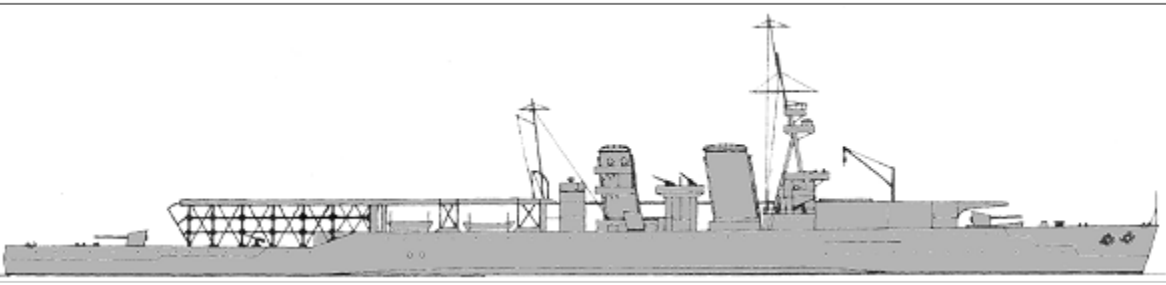
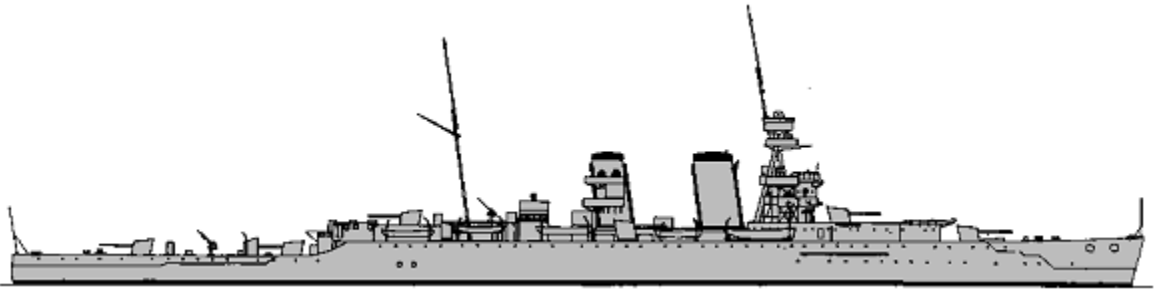

CVL	Argus	1	1	Argus	1918		20kts, 401p; 51magazines; 6x1-102/45, 20aircraft (4 Flycatcher, 12 Fairey IIIF)
	Hermes	1	2	Hermes	1924		13700t, 182.3x21.4x5.7m, 6b, 2gt, 40000hp, 25kts, 664p; 76belt, 25deck; 6x1-140/50, 2x1-102/45, 2x1-40/39, 20aircraft (6 Flycatcher, 9 Dart)
AV	Ark Royal	1	1	Ark Royal	1914		7400t, 111.6x15.5x5.5m, 2b, 1vte., 3000hp, 11kts, 180p; 4x1-76/50, 7aircraft (really none)
	Pegasus	1	2	Pegasus	1917	No picture	3300t, 101.2x13.1x4.6m, 6b, 2gt, 9500hp, 20kts, 280p; 2x1-76/45, 2x1-76/40, 9aircraft (really none)

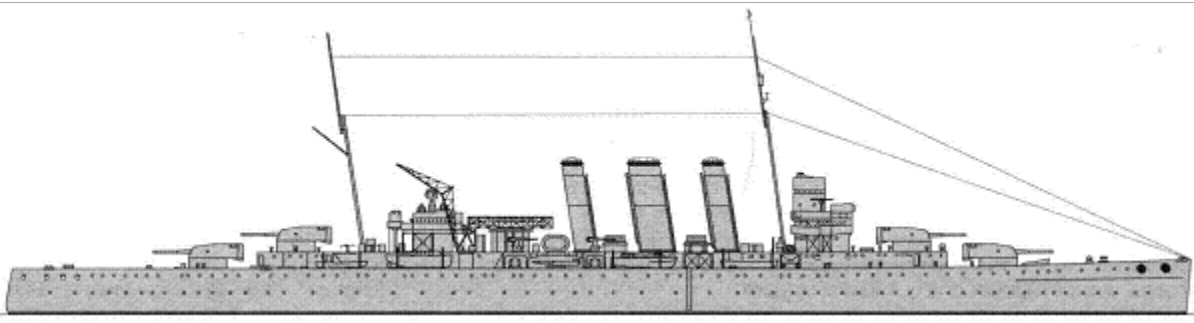
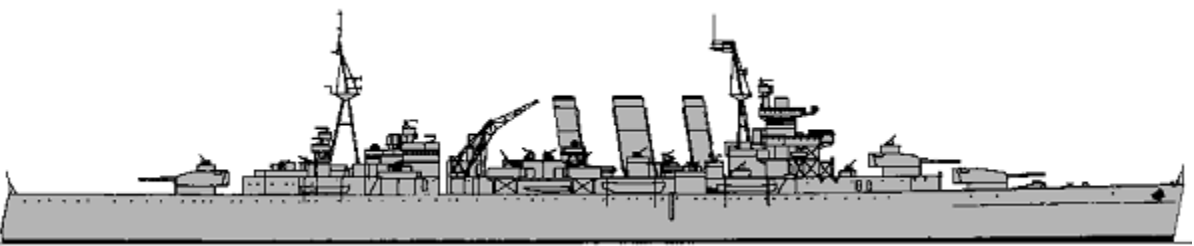
### CRUISERS

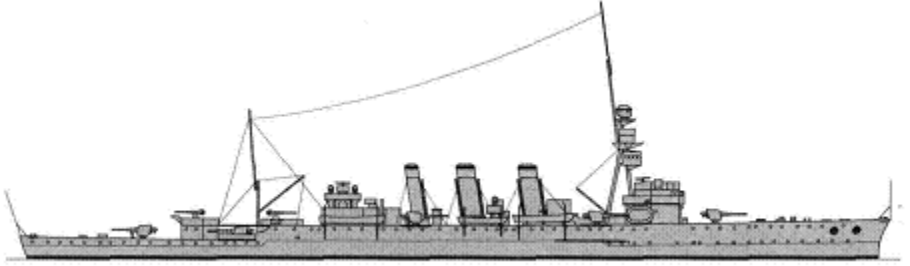
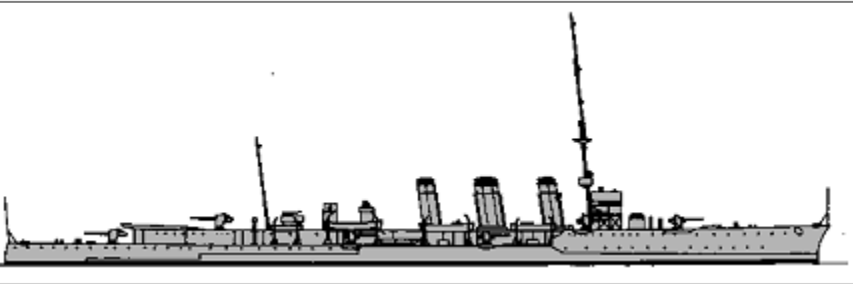
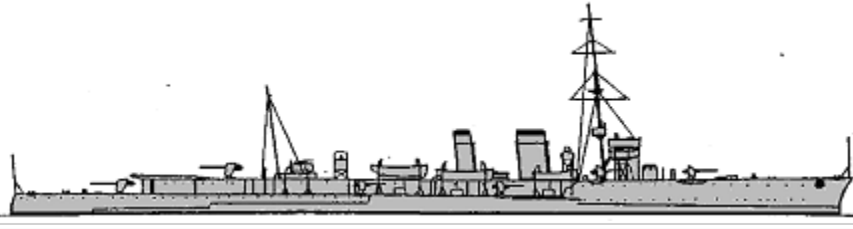
CA	Vindictive	1	1	Vindictive	1918		12000t, 184.4x19.8x5.9m, 12b, 4gt, 60000hp, 30kts, 560p; 76belt, 38deck, 76CT; 6x1-190/45, 3x1-102/45, 4x1-47/40, 1x1-40/39, 6-533TT
	Hawkins	2		Hawkins	1919		12300t, 184.4x19.8x5.9m, 8(2)-10(3, 4)b, 4gt, 55000(2)-65000(3, 4)hp, 29.5(2)-30.5(3, 4)kts, 712p; 76belt, 51gunhouses, 38deck, 76CT; 7x1-190/45, 4x1-102/45(2, 3), 3x1-102/45(4), 4x1-47/40(2), 2x1-40/39, 6-533TT, 1seaplane(3) (1 Fairey IIIF)
		3		Frobisher	1924		
		4		Effingham	1925		
	Kent	5		Cumberland	1928		
6			Berwick	1928			
7			Cornwall	1928			
8			Suffolk	1928			
13400-13540t, 192.0-192.9x20.8x6.3m, 8b, 4gt, 80000hp, 31.5kts, 710p; 25belt, 111magazines, 38deck, 25turrets; 4x2-203/50, 4x1-102/45, 4x1-							

						47/40, 4x1-40/39, 2x4-533TT
London	4	9	Kent	1928		13315t, 192.0-192.9x20.1x6.3m, 8b, 4gt, 80000hp, 32.3kts, 700p; 25belt, 102magazines, 25turrets, 38deck; 4x2-203/50, 4x1-102/45, 4x1-47/40, 4x1-40/39, 2x4-533TT
		10	London	1929		
		11	Devonshire	1929		
		12	Sussex	1929		
		13	Shropshire	1929		
Weymouth	1	1	Dartmouth	1911		5800t, 138.1x14.6x4.7m, 12b, 4t, 22000hp, 25kts, 475p; 102shields, 51deck; 8x1-152/50, 2x1-76/45, 4x1-47/40, 2-533TT
Birmingham	2	2	Birmingham	1914		6100t, 139.0x14.6x4.7m, 12b, 4t, 25000hp, 25.5kts, 480p; 51belt, 102shields, 38deck, 102CT; 9x1-152/45, 1x1-76/45, 4x1-47/40, 2-533TT
		3	Lowestoft	1914		
Caroline	4	4	Carysfort	1915		4733t, 135.9x12.6x4.9m, 8b, 4t, 40000hp, 28.5kts, 301p; 76belt, 102shields, 25deck; 4x1-152/45(4-6), 3x1-152/45(7), 2x1-102/45(5), 2x1-76/45(4, 6, 7), 4x1-47/40, 2x1-40/39, 4x2-533TT
		5	Cleopatra	1915		
		6	Comus	1915		
		7	Conquest	1915		
Calliope	2	8	Calliope	1915		4695t, 135.9x12.6x4.5m, 6b, 4(8)-2(9)gt, 37500(8)-40000(9)hp, 29.5(8)-29(9)kts, 368p; 102belt, 102shields, 25deck, 152CT; 4x1-152/45, 2x1-76/45, 4x1-47/40, 2x1-40/39, 2-533TT
		9	Champion	1915		
		10	Castor	1915		

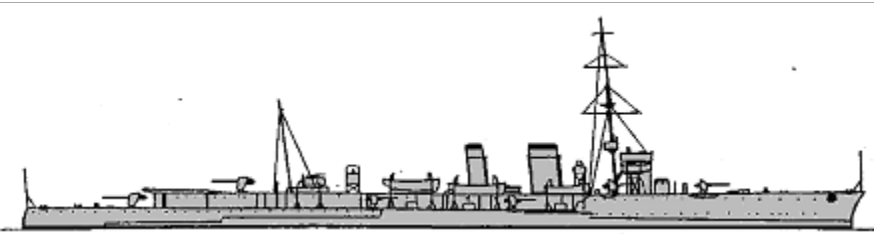
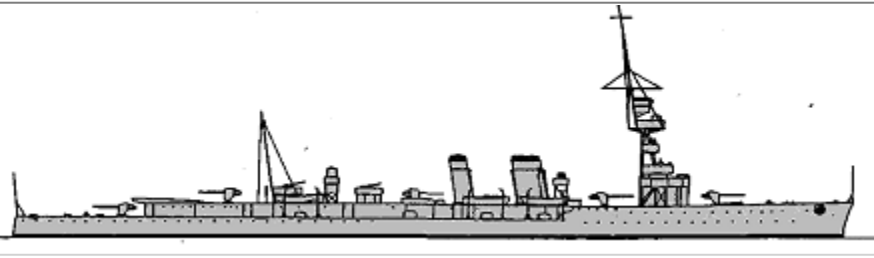
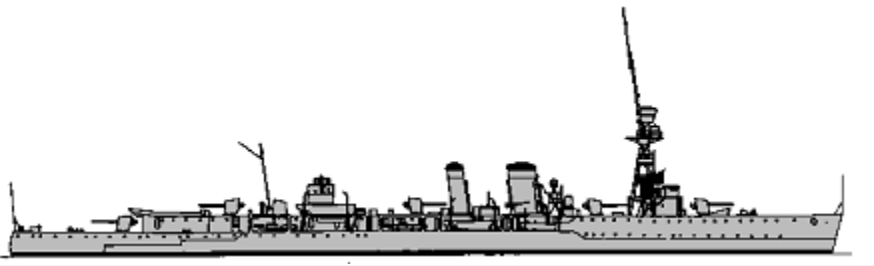
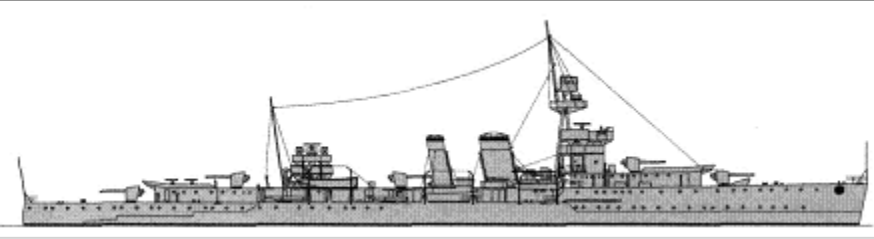
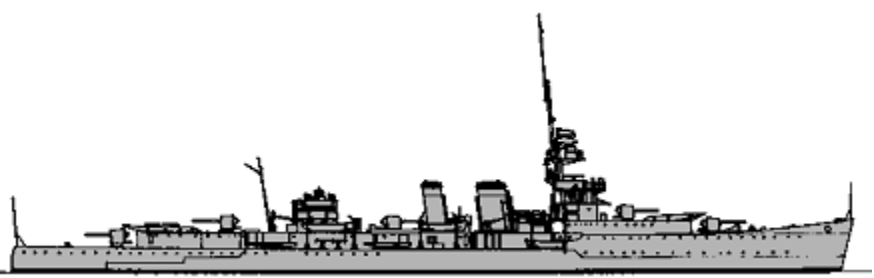
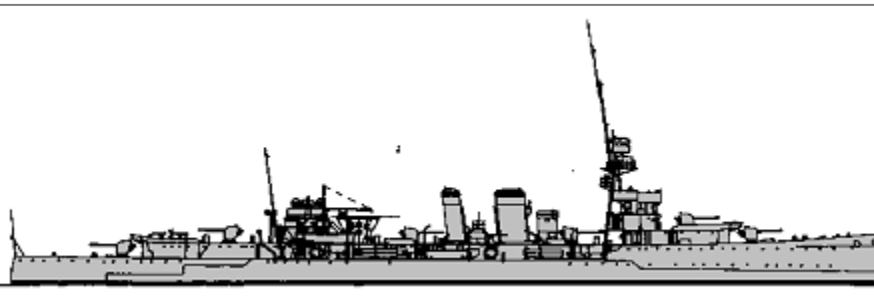



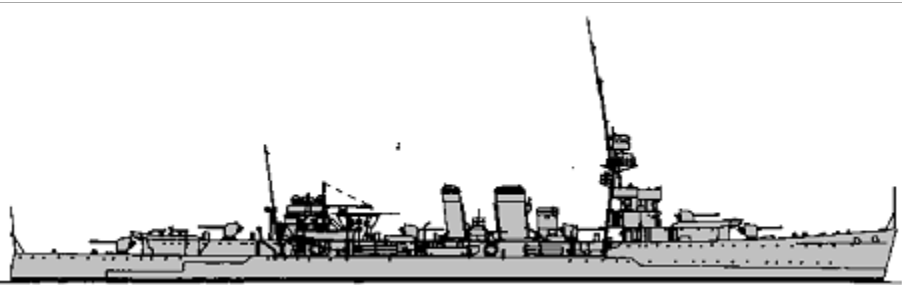
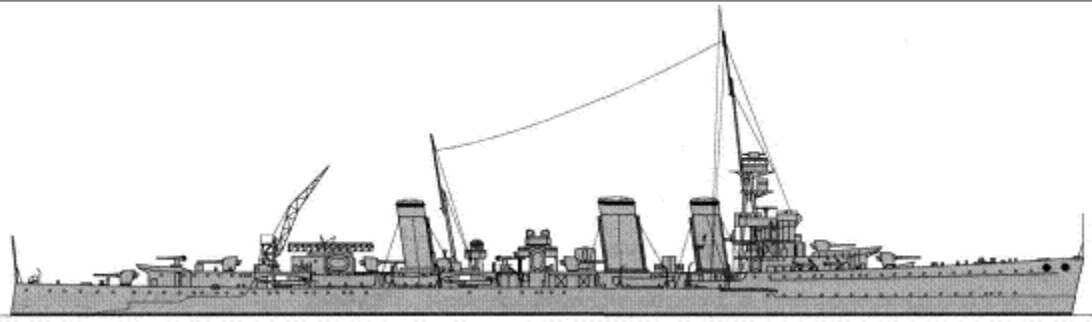
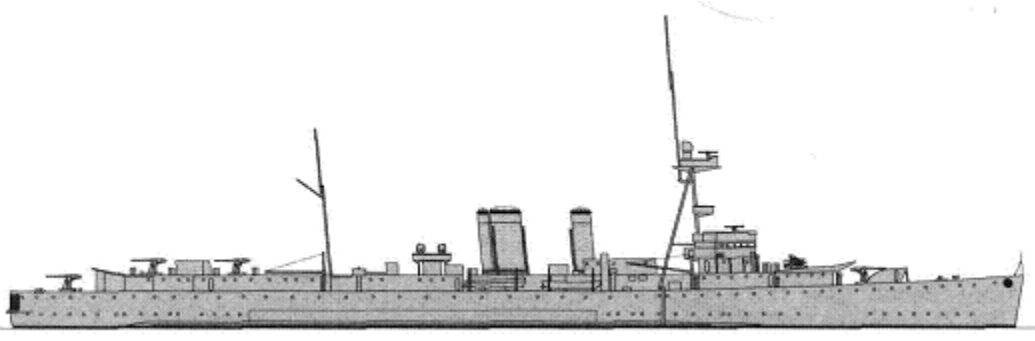

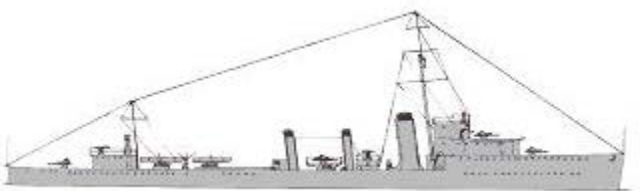
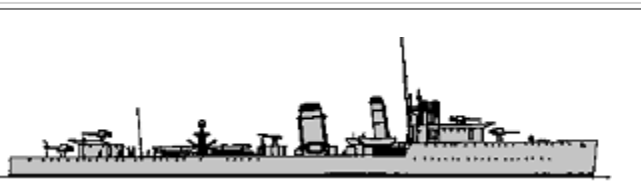

CL	Cambrian	4	11	Cambrian	1916		4799t, 135.9x12.6x4.5m, 6b, 4gt, 40000hp, 28.5kts, 368p; 76belt, 102shields, 25deck, 152CT; 4x1-152/45, 2x1-76/45, 4x1-47/40, 2x1-40/39(10, 11), 2-533TT
			12	Canterbury	1916		
			13	Constance	1916		
	Centaur	2	14	Centaur	1916		4870t, 135.9x12.8x4.1m, 6b, 4gt, 40000hp, 29kts, 437p; 76belt, 102shields, 25deck, 152CT; 4x1-152/45(14), 3x1-152/45(15), 2x1-76/45, 2x1-40/39, 2-533TT
			15	Concord	1916		
	Caledon	3	16	Caledon	1917		4950t, 137.2x13.0x5.0m, 6b, 2gt, 40000hp, 29kts, 400p; 76belt, 25shields, 25deck; 5x1-152/45, 2x1-76/45, 4x1-47/40, 2x1-40/39, 4x2-533TT
			17	Calypso	1917		
			18	Caradoc	1917		
	Ceres	5	19	Cardiff	1917		5020t, 137.2x13.3x4.5m, 6b, 2gt, 40000hp, 29kts, 460p; 76belt, 25shields, 25deck; 5x1-152/45, 2x1-76/45, 4x1-47/40, 2x1-40/39, 4x2-533TT
			20	Ceres	1917		
			21	Curlew	1917		
			22	Coventry	1918		
23			Curacoa	1918			
Carlisle	5	24	Carlisle	1918		5250t, 137.6x13.3x4.7m, 6b, 2gt, 40000hp, 29kts, 432p; 76belt, 25shields, 25deck; 5x1-152/45, 2x1-76/45, 4x1-47/40, 2x1-40/39, 4x2-533TT	
		25	Cairo	1919			
		26	Calcutta	1919			
		27	Colombo	1919			
		28	Capetown	1922			
Danae	3	29	Danae	1918		5870t, 143.6x13.9x5.0m, 6b, 2gt, 40000hp, 29kts, 450p; 76belt, 25shields, 25deck, 76CT; 6x1-152/45, 3x1-102/45, 2x1-40/39, 4x3-533TT	
		30	Dauntless	1918			
		31	Dragon	1918			
Delhi	3	32	Delhi	1919		5870t, 143.6x13.9x5.0m, 6b, 2gt, 40000hp, 29kts, 450p; 76belt, 25shields, 25deck, 76CT; 6x1-152/45, 3x1-102/45, 2x1-40/39, 4x3-533TT	
		33	Durban	1921			

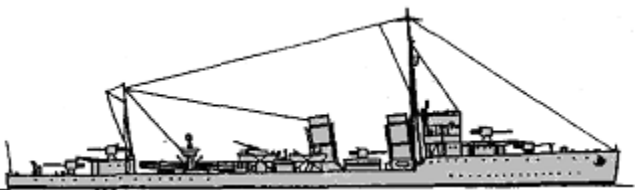
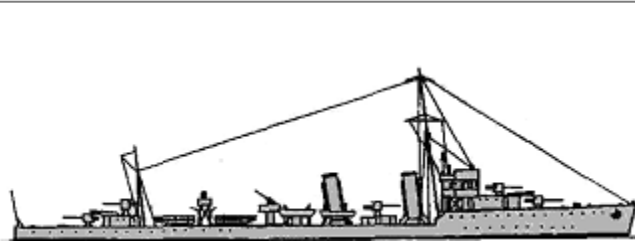
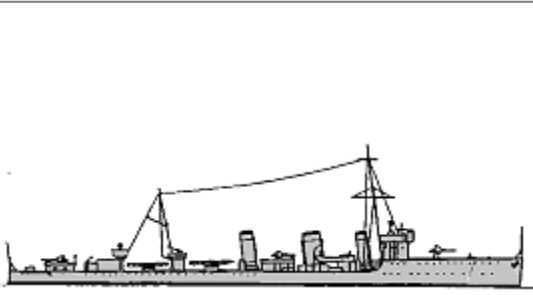
			34	Despatch	1922		
Emerald	2	35	Emerald	1926		9450t, 173.7x16.6x5.6m, 8b, 4gt, 80000hp, 33kts, 450p; 76belt, 25turret/shields, 25deck, 76CT; 7x1-152/45(35), (1x2+5x1)-152/45(36), 3x1-102/45, 4x1-47/40, 2x1-40/39, 4x4-533TT	
		36	Enterprise	1926			
CM	Adventure	1	1	Adventure	1927		8370t, 158.5x18.0x5.2m, 6b, 2gt/4dg, 4em(2), 40000/8000hp, 28kts, 395p; 25belt, 25deck; 4x1-120/40, 4x1-47/40, 4x1-40/39, 280mines

TORPEDO SHIPS

	Lightfoot	1	1	Abdiel	1916		1700t, 99.0x9.7x3.7m, 4b, 3t, 36000hp, 34.5kts, 104p; 2x1-102/40, 2x1-40/39, 80mines
Parker	3	2	Grenville	1916		1912t, 99.0x9.7x3.7m, 4b, 3t, 36000hp, 34kts, 116p; 4x1-102/40(2, 3), 2x1-102/40(4), 2x1-40/39, 2x2-533TT(2, 3), 80mines(4)	
		3	Saumarez	1916			
		4	Seymour	1916			
DL	V	5	5	Vampire	1917		1400t, 95.1x9.0x3.2m, 3b, 2gt, 27000hp, 34kts, 115p; 4x1-102/45, 2x1-40/39, 2x3-533TT, 1DCR
			6	Valentine	1917		
			7	Valhalla	1917		
			8	Valorous	1917		
			9	Valkyrie	1917		
			10	Shakespeare	1917		

Shakespeare	5	11	Spencer	1917		2000t, 100.3x9.6x3.8m, 4b, 2gt, 40000hp, 36kts, 183p; 5x1-120/45, 1x1-76/45, 2x1-40/39, 2x3-533TT, 2DCT, 1DCR
		12	Wallace	1919		
		13	Keppel	1924		
		14	Broke	1925		
Scott	7	15	Bruce	1918		2050t, 101.3x9.7x3.8m, 4b, 2gt, 40000hp, 36kts, 164p; 5x1-120/45, 1x1-76/45, 2x1-40/39, 2x3-533TT, 2DCT, 1DCR
		16	Douglas	1918		
		17	Campbell	1918		
		18	Stuart	1918		
		19	Montrose	1918		
		20	Malcolm	1919		
		21	Mackay	1919		
R-Admiralty	10	1	Romola	1916		1200-1244t, 84.1x8.1x2.7m, 3b, 2gt, 27000hp, 36kts, 82p; 3x1-102/40, 1x1-40/39, 2x2-533TT
		2	Rowena	1916		
		3	Restless	1916		
		4	Salmon	1916		
		5	Skate	1917		
		6	Tempest	1917		
		7	Tetrarch	1917		
		8	Thisbe	1917		
		9	Thruster	1917		
		10	Torrid	1917		
R-Thornycroft	2	11	Taurus	1917		1208t, 83.6x8.2-8.3x2.7m, 3b, 2gt, 27000hp, 36kts, 82p; 3x1-102/40, 1x1-40/39, 2x2-533TT
		12	Teazer	1917		
R-Yarrow	1	13	Tyrant	1917		1051t, 83.4x7.8x2.7m, 3b, 2t, 27000hp, 36kts, 82p; 3x1-102/40, 1x1-40/39, 2x2-533TT
Modified R	2	14	Umpire	1917		1225-1242t, 84.1x8.1x2.7m, 3b, 2gt, 27000hp, 36kts, 82p; 3x1-102/45, 1x1-40/39, 2x2-533TT
		15	Urchin	1917		
		16	Vanquisher	1917		
		17	Vanoc	1917		
		18	Vega	1917		
		19	Venturous	1917		
		20	Vendetta	1917		
		21	Venetia	1917		
		22	Verdun	1917		
23	Violent	1917				

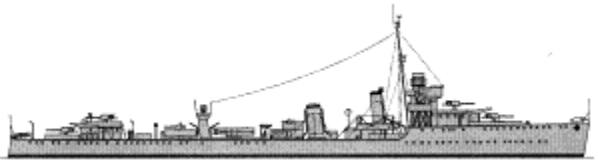
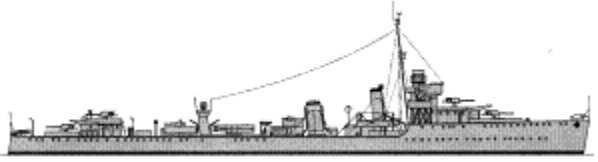
V-Admiralty	20	24	Vimiera	1917		1480-1523t, 95.1x9.0x3.2m, 3b, 2gt, 27000hp, 34kts, 134p; 4x1-102/45 (can be 3x1-102/45 on 16, 17, 19, 24, 30, 31, 35), 1x1-40/39, 2x3-533TT(18, 20-23, 25-29, 32-34), (1x3+1x2)-533TT(16, 17, 19, 24, 30, 31, 35) (can be 1x2-533TT on 16, 17, 19, 24, 30, 31, 35), 2DCT (or can be not on 16, 17, 19, 24, 30, 31, 35), 1DCR, MS, (can be 60mines on 16, 17, 19, 24, 30, 31, 35)
		25	Vivacious	1917		
		26	Vectis	1917		
		27	Vimy	1918		
		28	Vanessa	1918		
		29	Vanity	1918		
		30	Velox	1918		
		31	Versatile	1918		
		32	Vesper	1918		
		33	Vidette	1918		
		34	Vivien	1918		
		35	Vortigern	1918		
V-Thornycroft	2	36	Viceroy	1918		1512t, 95.1x9.4x2.9m, 3b, 2gt, 27000hp, 34kts, 134p; 4x1-102/45, 1x1-40/39, 2x3-533TT, 2DCT, 1DCR, MS
		37	Viscount	1918		
W-Admiralty	19	38	Wakeful	1917		1490t, 95.1x9.0x3.2m, 3b, 2gt, 27000hp, 34kts, 134p; 4x1-102/45 (can be 3x1-102/45 on 39, 42, 44, 46, 49), 1x1-40/39, 2x3-533TT (can be 1x3-533TT on 39, 42, 44, 46, 49), 2DCT, 1DCR, MS, (can be 60mines on 39, 42, 44, 46, 49)
		39	Watchman	1918		
		40	Walpole	1918		
		41	Whitley	1918		
		42	Walker	1918		
		43	Westcott	1918		
		44	Walrus	1918		
		45	Wolfhound	1918		
		46	Warwick	1918		
		47	Wessex	1918		
		48	Voyager	1918		
		49	Whirlwind	1918		
		50	Wrestler	1918		
		51	Winchelsea	1918		
		52	Winchester	1918		
		53	Westminster	1918		
		54	Windsor	1918		
		55	Wryneck	1918		
		56	Waterhen	1918		
W-Thornycroft	2	57	Woolsey	1918		1512t, 95.1x9.4x2.9m, 3b, 2gt, 27000hp, 34kts, 134p; 4x1-102/45, 1x1-40/39, 2x3-533TT, 2DCT, 1DCR, MS
		58	Woolston	1918		
		59	Simoom	1918		
		60	Scimitar	1918		





DD

61	Scotsman	1918
62	Scout	1918
63	Shark	1918
64	Sparrowhawk	1918
65	Splendid	1918
66	Sabre	1918
67	Sirdar	1918
68	Somme	1918
69	Senator	1918
70	Sepoy	1918
71	Seraph	1918
72	Swallow	1918
73	Tribune	1918
74	Trinidad	1918
75	Tactician	1918
76	Tara	1918
77	Scythe	1918
78	Seabear	1918
79	Seafire	1918
80	Searcher	1918
81	Sportive	1918
82	Tilbury	1918
83	Tintagel	1918
84	Trojan	1918
85	Saladin	1919
86	Shamrock	1919
87	Steadfast	1919
88	Sterling	1919
89	Seawolf	1919
90	Sardonyx	1919
91	Stormcloud	1919
92	Spindrift	1919
93	Serapis	1919
94	Serene	1919
95	Sesame	1919
96	Strenuous	1919
97	Stronghold	1919
98	Sturdy	1919
99	Truant	1919
100	Trusty	1919

S-Admiralty 47

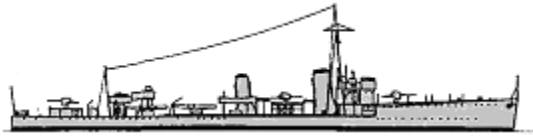









1225t, 84.1x8.1x2.7m, 3b, 2gt, 27000hp, 36kts, 90p; 3x1-102/40, 1x1-40/39, 2x2-533TT, 2DCT, 1DCR

		101	Turbulent	1919		
		102	Tenedos	1919		
		103	Thanet	1919		
		104	Thracian	1922		
		105	Shikari	1924		
S-Yarrow	3	106	Turquoise	1919		1060t, 83.4x7.8x3.0m, 3b, 2gt, 27000hp, 36kts, 90p; 3x1-102/40, 1x1-40/39, 2x2-533TT, 2DCT, 1DCR
		107	Tuscan	1919		
		108	Tyrian	1919		
S-Thornycroft	1	109	Tourmaline	1919		1240t, 84.1x8.3x3.2m, 3b, 2gt, 27000hp, 36kts, 90p; 3x1-102/40, 1x1-40/39, 2x2-533TT, 2x1-450TT, 2DCT, 1DCR
Modified W-Admiralty	14	110	Vansittart	1919		1508t, 95.1x9.0x3.2m, 3b, 2gt, 27000hp, 34kts, 127p; 4x1-120/45, 2x1-40/39, 2x3-533TT, 2DCT, 1DCR
		111	Volunteer	1919		
		112	Venomous	1919		
		113	Verity	1919		
		114	Wanderer	1919		
		115	Veteran	1919		
		116	Whitshed	1919		
		117	Wild Swan	1919		
		118	Witherington	1919		
		119	Wivern	1919		
		120	Wolverine	1920		
121	Worcester	1922				
122	Wren	1923				
123	Whitehall	1924				
Modified W-Thornycroft	2	124	Wishart	1920		1530t, 95.1x9.4x2.9m, 3b, 2gt, 30000hp, 35kts, 127p; 4x1-120/45, 2x1-40/39, 2x3-533TT, 2DCT, 1DCR
		125	Witch	1924		
Amazon	1	126	Amazon	1926		1812t, 98.5x9.6x3.8m, 3b, 2gt, 39500hp, 37kts, 138p; 4x1-120/45, 2x1-40/39, 2x3-533TT
Ambuscade	1	127	Ambuscade	1927		1585t, 98.1x9.5x3.5m, 3b, 2gt, 33000hp, 37kts, 138p; 4x1-120/45, 2x1-40/39, 2x3-533TT

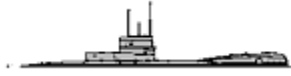

## SUBMARINES

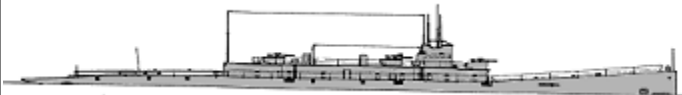
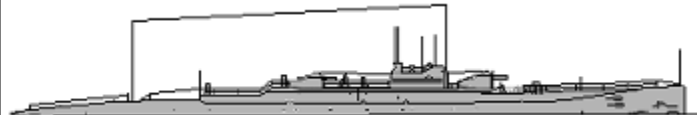

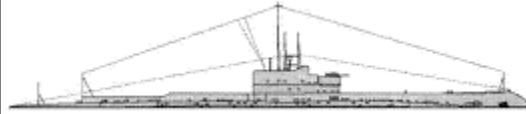





SS	E-II	1	1	E51	1917		667/807t, 55.6x4.6x3.8m, 2d/em, 1600/840hp, 15/9kts, 30p, 30m; 1x1-76/50, 3-450TT, 20mines
	L-I	8	2	L1	1917		891/1074t, 70.4x7.2x4.0m, 2d/em, 2400/1600hp, 17/10.5kts, 35p, 50m; 1x1-102/40, 6-450TT
			3	L2	1917		
			4	L7	1917		
			5	L3	1918		
			6	L4	1918		
			7	L5	1918		
			8	L6	1918		
			9	L8	1918		
	M	2	10	M2	1920		1788(10)-1745(11)/1946t, 90.2(10)-93.2(11)x7.5x4.9(10)-4.8(11)m, 2d/em, 2400/1600hp, 15/9kts, 65p, 30m; 1x1-76/45, 4-450TT(10), 4-533TT(11), 100mines(11), 1seaplane(10) (1 Peto)
			11	M3	1920		
	H-II	14	12	H23	1918		423/510t, 52.4x4.8x4.0m, 2d/em, 480/620hp, 11.5/10.5kts, 22p, 30m; 4-533TT
			13	H24	1918		
			14	H27	1918		
			15	H28	1918		
			16	H30	1918		
			17	H31	1919		
			18	H32	1919		
			19	H33	1919		
			20	H34	1919		
			21	H43	1919		
			22	H48	1919		
			23	H49	1919		
			24	H44	1920		
			25	H50	1920		
	R	1	26	R4	1919		410/503t, 49.9x4.6x3.5m, 1d/2em(1), 240/1200hp, 9.5/15kts, 22p, 75m; 6-450TT
	L-II	16	27	L11	1918		890/1080t, 72.7x7.2x4.0m, 2d/em, 2400/1600hp, 17/10.5kts, 38p, 50m; 1x1-102/40, 4-533TT, 2-450TT(30, 31, 33-37, 39-42), 16mines(27-29, 32), 14mines(38)
			28	L12	1918		
			29	L14	1918		
			30	L15	1918		
			31	L16	1918		
			32	L17	1918		
			33	L18	1919		
			34	L19	1919		
			35	L20	1919		
			36	L33	1919		
			37	L21	1920		

			38	L25	1920		
			39	L22	1921		
			40	L23	1924		
			41	L26	1926		
			42	L27	1926		
L-III	6		43	L56	1919		960/1150t, 71.6x7.2x4.0m, 2d/em, 2400/1600hp, 17/10.5kts, 44p, 50m; 2x1-102/40(45), 1x1-102/40(43, 44, 46-48), 6-533TT
			44	L71	1920		
			45	L52	1921		
			46	L69	1923		
			47	L54	1924		
			48	L53	1925		
K-II	1	49	K26		1923		2140/2530t, 107.0x8.5x4.9m, 2b, 2gt/4em(2), 10500/1440hp, 23.5/9.5kts, 59p, 50m; 3x1-102/40, 6-533TT
X	1	50	X1		1925		2780/3600t, 110.8x9.1x4.8m, 2d+2dg/2em, 7000/2400hp, 19.5/8kts, 110p, 60m; 2x2-132/42, 6-533TT
Oberon	1	51	Oberon		1927		1598/1831t, 82.2x8.5x4.7m, 2d/em, 2950/1350hp, 13.7/7.5kts, 54p, 60m; 1x1-102/40, 8-533TT
Odin	4		52	Odin	1929		1781/2038t, 86.4x9.1x4.9m, 2d/em, 4520/1390hp, 17.5/8kts, 53p, 95m; 1x1-102/40, 8-533TT
			53	Osiris	1929		
			54	Oswald	1929		
			55	Otus	1929		

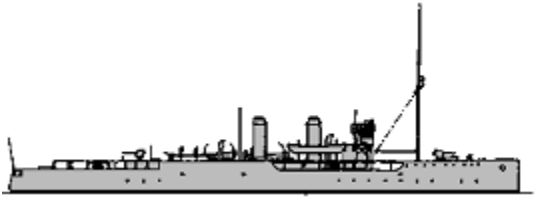
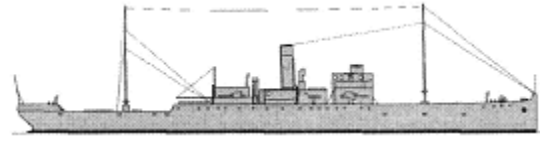

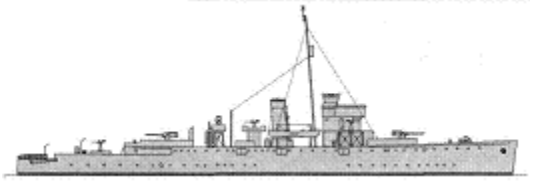
## ESCORTS

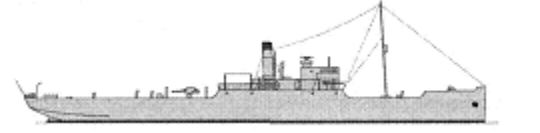
Acacia	9	1	Bluebell	1915		1275t, 80.0x10.1x3.4m, 2b, 1vte, 1800hp, 16.5kts, 90p; 2x1-102/40, 2x1-40/39, 2DCT, 1DCR, MS
		2	Daffodil	1915		
		3	Dahlia	1915		
		4	Foxglove	1915		
		5	Hollyhock	1915		
		6	Laburnum	1915		
		7	Lily	1915		
		8	Magnolia	1915		
		9	Veronica	1915		
Azalea	2	10	Clematis	1915		1275t, 80.0x10.1x3.4m, 2b, 1vte, 1800hp, 16.5kts, 90p; 2x1-102/40, 2x1-47/50, 2DCT, 1DCR, MS
		11	Heliotrope	1915		





SL	Arabia	11	12	Rosemary	1915		1350t, 81.7x10.2x3.4m, 2b, 1vte, 2000hp, 16kts, 104p; 2x1-102/40 or 2x1-120/40, 2x1-47/50, 2DCT, 1DCR, MS
			13	Cornflower	1916		
			14	Crocus	1916		
			15	Cyclamen	1916		
			16	Delphinium	1916		
			17	Godetia	1916		
			18	Lupin	1916		
			19	Snapdragon	1916		
			20	Verbena	1916		
			21	Wallflower	1916		
			22	Wisteria	1916		
	Aubretia	1	23	Heather	1916		1450t, 81.7x10.2x3.4m, 2b, 1vte, 2500hp, 17.5kts, 92p; 2x1-102/40, 1x1-47/50, 2DCT, 1DCR
	Anchusa	3	24	Bryony	1917		1493t, 80.0x10.7x3.5m, 2b, 1vte, 2500hp, 17.5kts, 119p; 2x1-102/40, 2x1-76/40, 2DCT, 1DCR
25			Chrysanthemum	1918			
26			Harebell	1918			
	Bridgewater	2	27	Bridgewater	1929		1600t, 81.2x10.4x3.7m, 2b, 2gt, 2000hp, 16.5kts, 100p; 2x1-102/45, 2x1-47/40, 1DCR, MS
28			Sandwich	1929			
FS	P-boat	3	1	P40	1916		613t, 74.5x7.2x2.4m, 2b, 2t, 3500hp, 20kts, 54p; 1x1-102/40, 1x1-40/39, 3x1-356TT, 2DCR
			2	Spey	1917		
			3	P59	1917		
	PC-boat	4	4	Dart	1918		780t, 75.3x8.2x2.4m, 2b, 2t, 3500hp, 20kts, 55p; 1x1-102/40, 2x1-76/40, 2x1-356TT, 2DCR
			5	PC74	1918		
PC	Z-whaler	1	1	Cachalot	1915		346t, 40.5x7.6x2.6m, 2b, 1vte, 1200hp, 13kts, 26p; 1x1-76/50, 2DCT

## OTHER FIGHTING SHIPS

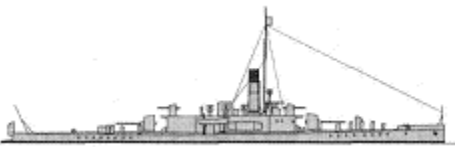

	Woodcock	1	1	Woodlark	1898	No picture	150t, 44.2x7.3x0.6m, 1b, 1vte, 550hp, 13kts, 25p; 2x1-57/40
	Moorhen	2	2	Moorhen	1901		180t, 48.7x7.5x0.8m, 1b, 1vte, 670hp, 13kts, 35p; 2x1-57/40
			3	Teal	1901		
	Widgeon	1	4	Widgeon	1904		195t, 48.7x7.5x1.0m, 1b, 1vte, 800hp, 12.5kts, 35p; 2x1-57/40

PR	Insect	11	5	Aphis	1915		750t, 72.4x11.0x1.2m, 2b, 2vte, 2000hp, 14kts, 54-65p; 2x1-152/40(5-8, 10-15), 1x1-152/40(9), 1x1-76/40				
			6	Gnat	1915						
			7	Mantis	1915						
			8	Scarab	1915						
			9	Bee	1916						
			10	Cicala	1916						
			11	Cockchafer	1916						
			12	Cricket	1916						
			13	Ladybird	1916						
			14	Moth	1916						
			15	Tarantula	1916						
			Peterel	2	16			Peterel	1927	No picture	400t, 56.4x8.8x1.3m, 2b, 2gt, 2250hp, 16kts, 55p; 2x1-76/45
					17			Gannet	1928		
			Tern	2	18			Seamew	1928	No picture	330t, 51.2x8.2x1.3m, 2b, 2gt, 1370hp, 14kts, 55p; 2x1-76/45
					19			Tern	1928		

### COASTAL FORCES

PT	CMB-40	1	1	CMB12	1916		5t, 13.7x2.6x0.9m, 1pe, 250hp, 25kts, 3p; 1-450TT
	CMB-55	6	2 - 7	CMB14A ... 120F	1917 - 1922		11t, 18.3x3.4x0.9m, 2pe, 500-900hp, 35-41kts, 5p; (1-2)-450TT, 1DCR
	CMB-70	2	8, 9	CMB103MT, 104MT	1922		24t, 22.1x4.3x1.1m, 2pe, 1400hp, 36.6kts, 5p; 1DCR, 7mines





### AMPHIBIOUS

LCU	X1	12	1	X21	1915		160t, 32.2x6.4x1.1m, 1sd, 60hp, 8kts, ?p; 500troops
			2	X23	1915		
			3	X31	1915		
			4	X36	1915		
			5	X45	1915		
			6	X64	1915		
			7	X95	1915		
			8	X103	1915		
			9	X131	1915		
			10	X134	1915		
			11	X140	1915		
			12	X149	1915		
	X201	6	13	X201	1916		137t, 29.6x6.1x1.1m, 1sd, 60hp, 8kts, ?p; 500troops
			14	X206	1916		
			15	X209	1916		
			16	X213	1916		

			17	X217	1916		
			18	X225	1916		
LCU(x)	DX1	2	1	DX1	1916		137t, 29.6x6.1x1.1m, ?p; 500troops
			2	DX2	1916		
LC	MLC1	1	1	MLC1	1926	No picture	26t, 12.2x3.5x0.4m, 2pe, 68hp, 4.7kts, 3p; 100troops
	MLC10	1	2	MLC10	1929	No picture	32t, 13.0x3.6x0.5m, 2pe, 68hp, 5kts, 3p; 1 12t tank or 100 troops

### MINE WARFARE

ML	M15	1	1	Medea	1915		650t, 54.0x9.4x2.0m, 2b, 2vte, 650hp, 9kts, 69p; 50mines
	M29	3	2	Medusa	1915		580t, 54.0x9.4x1.8m, 2b, 2vte, 400hp, 9kts, 72p; 50mines
			3	Melpomene	1915		
4			Minerva	1915			
AML	-	2	1	Kate Lewis	1916		207t, 24 mines
			2	Strathcoe	1916		215t, 24 mines
MS	Hunt-II	28	1	Aberdare	1918		930t, 70.4x8.7x2.3m, 2b, 2vte, 2200hp, 16kts, 74p; 1x1-102/40, 1x1-76/40, MS
			2	Abingdon	1918		
			3	Derby	1918		
			4	Fareham	1918		
			5	Harrow	1918		
			6	Pangbourne	1918		
			7	Saltash	1918		
			8	Stoke	1918		
			9	Sutton	1918		
			10	Tiverton	1918		
			11	Widnes	1918		
			12	Albury	1919		
			13	Alresford	1919		
			14	Bagshot	1919		
			15	Carstairs	1919		
			16	Caterham	1919		
			17	Dundalk	1919		
			18	Dunoon	1919		
			19	Elgin	1919		
			20	Fermoy	1919		
			21	Forres	1919		
			22	Huntley	1919		
			23	Lydd	1919		

			24	Marazion	1919			
			25	Petersfield	1919			
			26	Ross	1919			
			27	Saltburn	1919			
			28	Selkirk	1919			
TL	Mersey	9	1	Moy	1917		665t, 45.1x7.2x2.8m, 1b, 1vte, 600hp, 11kts, ?p; 1x1-76/40, MS	
			2	Ouse	1917			
			3	Doon	1917			
			4	Excellent	1918			
			5	Colne	1918			
			6	Cherwell	1918			
			7	Blackwater	1918			
			8	Boyne	1918			
			9	James Ludford	1919			
	Castle	2	10	Madras	1919		547t, 40.8x7.2x2.8m, 1b, 1vte, 480hp, 10.5kts, ?p; 1x1-76/40, MS	
			11	Sealdah	1919			
	Axe		4	12	Dee	1916		520t, 42.3x7.2x3.7m, 1b, 1vte, 490hp, 10.5kts, 20p; 1x1-75/50, MS
				13	Garry	1916		
				14	Kennet	1916		
				15	Liffey	1916		
DF	Admiralty steel	22	1	Billow	1918		200t, 28.4x5.7x2.3m, 1b, 1vte, 270hp, 9kts, ?p; 1x1-57/40, MS	
			2	Cascade	1918			
			3	Cloud	1918			
			4	Coldsnap	1918			
			5	Crescent Moon	1918			
			6	Eddy	1918			
			7	Flicker	1918			
			8	Glitter	1918			
			9	Halo	1918			
			10	Harmattan	1918			
			11	Horizon	1918			
			12	Indian Summer	1918			
			13	Landfall	1918			
			14	Leeward	1918			
			15	Lunar Bow	1918			
			16	Mist	1918			
			17	Noontide	1918			
			18	Sheen	1918			
			19	Shower	1918			

		20	Seabreeze	1919			
		21	Sundown	1919			
		22	Whirlpool	1920			
	Admiralty wooden	7	23	Antyclone	1918		175t, 28.7x6.1x2.2m, 1b, 1vte, 270hp, 9kts, ?p; 1x1-57/40, MS
			24	Avalanche	1918		
			25	Fiery Cross	1918		
			26	Flat Calm	1918		
			27	Full Moon	1918		
			28	Midnight Sun	1918		
			29	Fumarole	1919		
ATL	-	1	Vernon	1916		215brt	

NAVAL AVIATION *(approximately, maximal number of delivered planes signed)*

Deck planes	F: 193 Flycatcher I; TB: 117 Dart II; B: 20 Ripon II; R: 207 Fairey IIID
Seaplanes	R: 90 Fairey IIIF I, 33 Fairey IIIF II

[home](#)[World navies yesterday](#)[1930](#)

# UNITED STATES OF AMERICA 01 January 1930

*IN SERVICE: 18 battleships, 2 fleet aircraft carriers, 1 light aircraft carrier, 1 seaplane tender, 9 armoured cruisers, 1 heavy cruiser, 3 protected cruisers, 2 scout cruisers, 10 light cruisers, 270 destroyers, 121 submarines, 52 patrol ships, 5 armed yachts, 5 gunboats, 8 river gunboats, 23 submarine chasers, 18 minelayers, 37 minesweepers, 25 Coast Guard destroyers, 25 Coast Guard patrol ships, 53 Coast Guard patrol boats, 203 Coast Guard launches*

## CAPITAL SHIPS

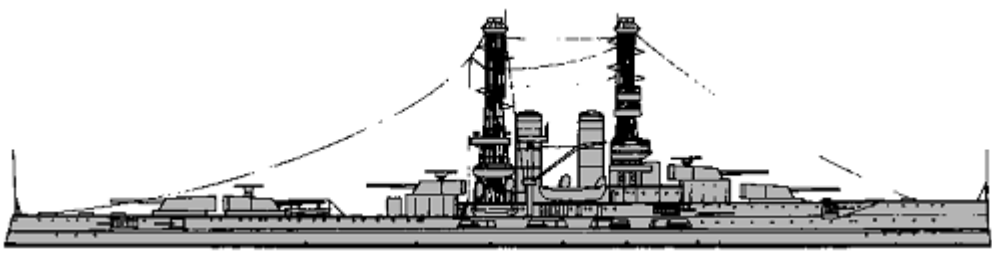
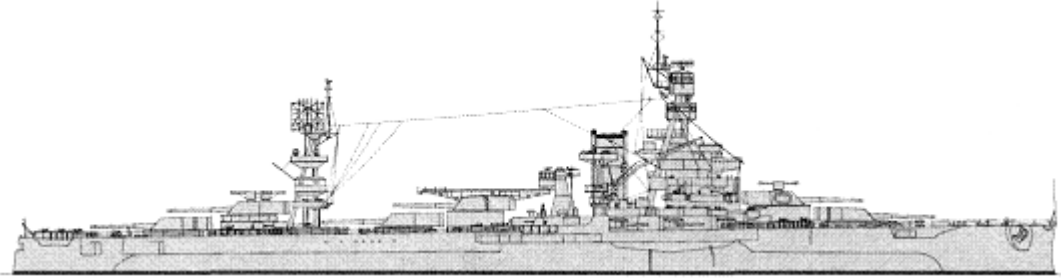
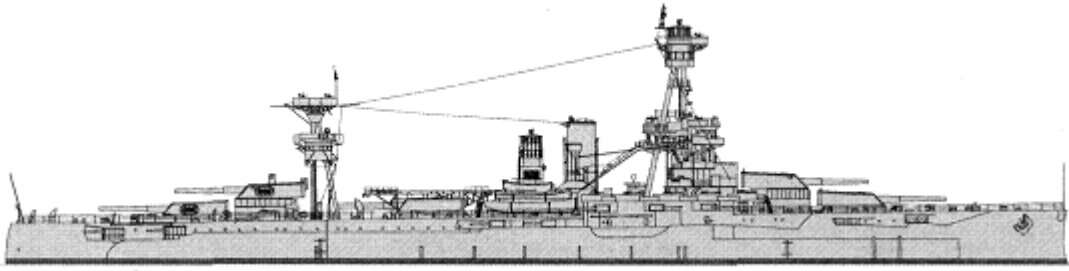
Florida	1	BB30	Florida	1911		22726t, 159.0x32.3x9.7m, 12b, 4t, 28000hp, 21kts, 1171p; 280belt, 305turrets, 127deck, 292CT; 5x2-305/45, 12x1-127/51, 8x1-76/50, 3seaplanes (3 OL or O2U)
	2	BB31	Utah	1911		
Wyoming	3	BB32	Wyoming	1912		30610t, 171.3x32.3x9.1m, 4b, 4t, 28000hp, 21kts, 1242p; 280belt, 305turrets, 119deck, 292CT; 6x2-305/50, 16x1-127/51, 8x1-76/50, 3seaplanes (3 OL or O2U)
	4	BB33	Arkansas	1912		
New York	5	BB34	New York	1914		31924t, 174.7x32.3x9.2m, 6b, 2vte, 28100hp, 21kts, 1290p; 305belt, 356turrets, 114deck, 305CT; 5x2-356/45, 16x1-127/51, 8x1-76/50, 8x1-12.7/90, 3seaplanes (3 OL or O2U)
	6	BB35	Texas	1914		
	7	BB36	Nevada	1916		28400(36)-31706(37)t, 177.7x29.1(36)-32.9(37)x8.7(36)-9.0(37)m, 12b(36)-6b(37), 2t(36)-2vte(37), 26500(36)-25000(37)hp, 20.5kts, 864(36)-1374(37)p;

BB	Nevada	2	8	BB37	Oklahoma	1916		343belt, 457-406turrets, 127(36)-178(37)deck, 406CT; 2x3-356/45, 2x2-356/45, 21x1-127/51(36), 12x1-127/51(37), 8x1-127/25(37), 8x1-76/50(36), 2-533TT(36), 1seaplane(36) (1 O2U), 3seaplanes(37) (3 OL or O2U)
	Pennsylvania	2	9	BB38	Pennsylvania	1916		32567t, 185.4x29.6x8.8m, 12b, 4t, 31500hp, 21kts, 915p; 343belt, 76deck, 457turrets, 406CT; 4x3-356/45, 22x1-127/51, 4x1-76/50, 2-533TT
			10	BB39	Arizona	1916		
	New Mexico	3	11	BB40	New Mexico	1918		33000t, 190.2x29.7x9.1m, 9b, 2tg(40), 2 em(40), 2t(41, 42), 27500(40)-32000(41, 42)hp, 21kts, 1084p; 343belt, 89deck, 457turrets, 406CT; 4x3-356/50, 20x1-127/51(40), 12x1-127/51(41, 42), 8x1-76/50, 2-533TT, 1seaplane(40, 42) (1 O2U), 3seaplanes(41) (3 OL or O2U)
			12	BB41	Mississippi	1917		
			13	BB42	Idaho	1919		
Tennessee	2	14	BB43	Tennessee	1920		33190t, 190.2x29.7x9.2m, 8b, 2tg, 4em, 26800hp, 21kts, 1083p; 343belt, 127deck, 457turrets, 406CT; 4x3-356/50, 12x1-127/51, 8x1-127/25, 8x1-12.7/90, 2-533TT, 3seaplanes (3 OL or O2U)	
		15	BB44	California	1921			
Colorado	3	16	BB45	Colorado	1923		33590t, 190.2x29.7x9.2m, 8b, 2tg, 4em, 28900hp, 21kts, 1080p; 343belt, 127deck, 457turrets, 406CT; 4x2-406/45, 12x1-127/51, 8x1-127/25, 8x1-12.7/90, 2-533TT, 3seaplanes (3 OL or O2U)	
		17	BB46	Maryland	1921			
		18	BB48	West Virginia	1923			

## AIRCRAFT CARRYING SHIPS

15150t,

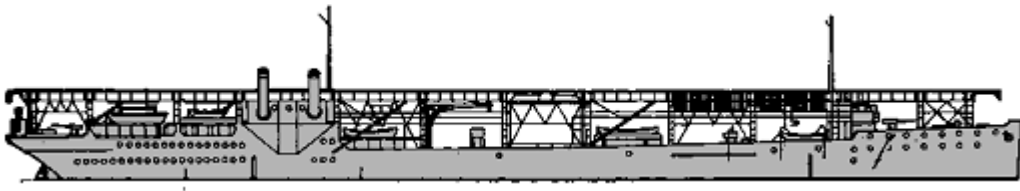
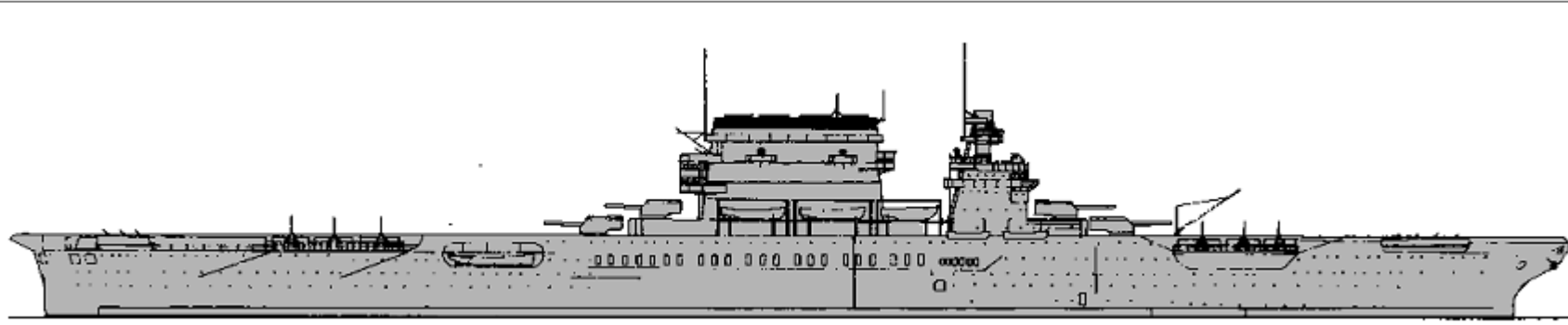

CV	Langley	1	1	CV1	Langley	1913		165.3x19.9x6.3m, 3b, 2tg, 2em, 6500hp, 15.5kts, 468p; 4x1-127/51, 34aircraft (15 F4B, 15 O2U)
	Lexington	2	CV2	Lexington	1927		43055t, 270.7x32.1x10.2m, 16b, 4tg, 4em, 180000hp, 33.2kts, 2327p; 178belt, 32deck, 51CT; 4X2-203/55, 12X1-127/25, 48X1-12.7/90, 63aircraft (36 F2B, F3B and F4B, 43 F8C, OL and O2U)	
			CV3	Saratoga	1927			
AV	Wright	1	1	AV1	Wright			1921

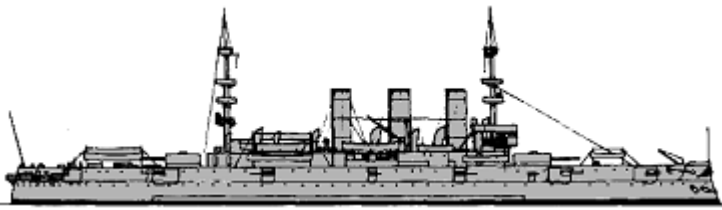
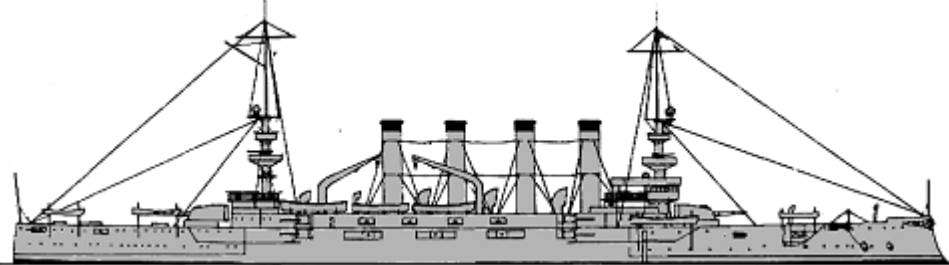

### CRUISERS

CA	New York	1	1	CA2	Rochester	1893		9021t, 117.0x19.8x7.3m, 4b, 4vte(2), 5300hp, 12kts, 566p; NS102belt, 152deck, KS165turrets, 190CT; 2x2-203/45, 8x1-127/50, 2x1-76/50
	Pennsylvania	3	2	CA4	Pittsburgh	1905		15138t, 153.6x21.2x7.3m, 16b, 2vte, 23000hp, 22kts, 829-928p; KS/HS152belt, 102deck, 165turrets, 229CT; 2x2-203/45, 8x1-152/50(4), 4x1-152/50(5, 7), 12x1-76/50, 2-450TT
			3	CA5	Huntington	1905		
			4	CA7	Pueblo	1905		
	Tennessee	3	5	CA11	Seattle	1906		
			6	CA12	Charlotte	1908		
			7	CA13	Missoula	1908		

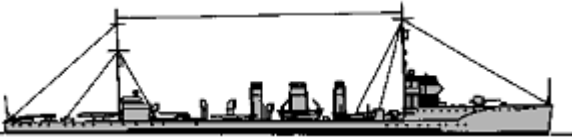

St. Louis	2	8	CA18	St. Louis	1906		10839t, 129.9x20.1x6.9m, 16b, 2vte, 21000hp, 22kts, 673-767p; HS102belt, 76deck, 102casemate, 127CT; 12x1-152/50, 6x1-76/50
		9	CA19	Charleston	1905		
Pensacola	1	10	CL25	Salt Lake City	1929		11512t, 178.5x19.9x5.9m, 8b, 4gt, 107000hp, 32.5kts, 631p; 102belt, 45deck, 64turrets, 32CT; (2x3+2x2)-203/55, 4x1-127/25, 2x3-533TT, 4seaplanes (4 O2U)
Chester	2	1	CL1	York	1908		4687t, 129.0x14.3x5.1m, 12b, 4t(1), 2vte(2), 16000hp, 24(1)-22.4(2)kts, 359p; 51belt, 25deck; 4x1-127/51, 3x1-76/50, 2-533TT
		2	CL2	Birmingham	1908		
Omaha	10	3	CL4	Omaha	1923		9508t, 169.4x16.9x4.1m, 12b, 4gt, 90000hp, 34kts, 458p; 76belt, 38deck, 32CT; (2x2+8x1)-152/53, 4x1-76/50, 2x3-533TT, 2seaplanes (2 O2U)
		4	CL5	Milwaukee	1923		
		5	CL6	Cincinnati	1924		
		6	CL7	Raleigh	1924		
		7	CL8	Detroit	1923		
		8	CL9	Richmond	1923		
		9	CL10	Concord	1923		
		10	CL11	Trenton	1924		
		11	CL12	Marblehead	1924		
		12	CL13	Memphis	1925		
Olympia	1	13	CL15	Olympia	1895		6558t, 104.9x16.2x6.6m, 6b, 2vte, 13500hp, 20kts, 447p; HS/NS51/121deck, 114barbettes, 127CT; 10x1-127/51
Denver	2	14	CL16	Denver	1904		3514t, 94.1x13.4x4.8m, 6b, 2vte, 4500hp, 16.5kts, 339p; 8/64deck, 44casemates; 8x1-127/50
		15	CL19	Galveston	1905		

## TORPEDO SHIPS

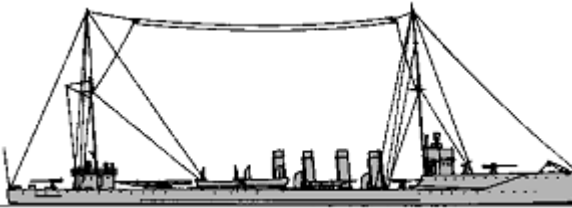
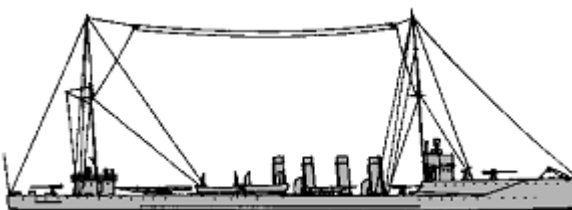
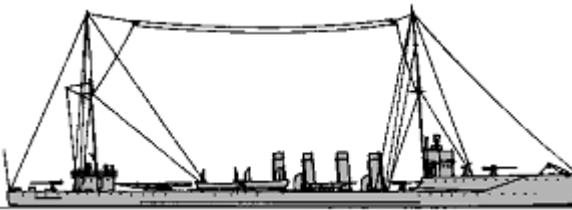
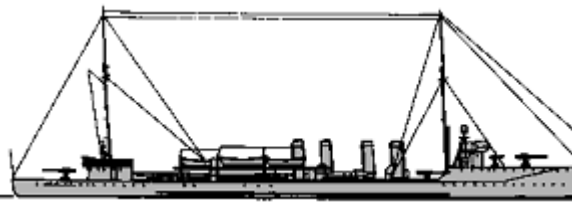
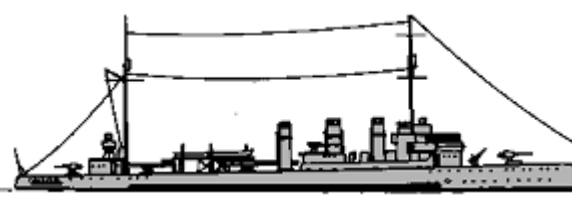
Paulding	5	1	DD23	Drayton	1910		887t, 89.6x8.0x2.4m, 4b, 3t(23)-2t(26, 27, 30, 31), 12000(23)-10000(26, 27, 30)-13000(31)hp, 29.5(23)-28(26, 27, 30)-30(31)kts, 86p; 5x1-76/50, 3x2-450TT, 1DCT, 2DCR
		2	DD26	Perkins	1910		
		3	DD27	Sterett	1910		
		4	DD30	Warrington	1911		
		5	DD31	Mayrant	1911		
Monaghan	3	6	DD34	Walke	1911		883t, 89.5x8.2x2.5m, 4b, 2t(34)-3t(38, 42), 10000(34)-12000(38, 42)hp, 28(34)-29.5(38, 42)kts, 89p; 5x1-76/50, 3x2-450TT, 1DCT, 2DCR
		7	DD38	Jarvis	1912		
		8	DD42	Jenins	1912		
Cassin	5	9	DD46	Duncan	1913		1235t, 93.1x9.2x3.0m, 4b, 2t/vte, 16000hp, 29kts, 98p; 4x1-102/50, 4x2-450TT, 1DCT, 2DCR
		10	DD47	Aylwin	1914		
		11	DD48	Parker	1913		
		12	DD49	Benham	1914		
		13	DD50	Balch	1914		
O'Brien	4	14	DD51	O'Brien	1915		1171t, 93.1x9.5x2.9m, 4b, 2t/vte(51-53)-2t/t(55), 17000hp, 29kts, 101p; 4x1-102/50, 4x2-533TT, 1DCT, 2DCR
		15	DD52	Nicholson	1915		
		16	DD53	Winslow	1915		
		17	DD55	Cushing	1915		
Tucker	1	18	DD60	Wadsworth	1915		1205t, 96.1x9.1x2.8m, 4b, 2gt, 17500hp, 29.5kts, 99p; 4x1-102/50, 4x2-533TT, 2DCR
Sampson	3	19	DD63	Sampson	1916		1225t, 96.1x9.1x2.9m, 4b, 2t/1t(2)(63, 64)-2t/t(66), 17500hp, 29.5kts, 99p; 4x1-102/50, 4x3-533TT, 1DCT, 2DCR
		20	DD64	Rowan	1916		
		21	DD66	Allen	1917		
Caldwell	6	22	DD69	Caldwell	1917		1187t, 96.2x9.3x2.7m, 4b, 2gt(69-71, 74)-3t/1gt(3)(72, 73), 18500hp, 30kts, 100p; 4x1-102/50, 2x1-76/23, 4x3-533TT, 1DCT, 2DCR
		23	DD70	Craven	1918		
		24	DD71	Gwin	1920		
		25	DD72	Conner	1918		
		26	DD73	Stockton	1917		
		27	DD74	Manley	1917		
		28	DD75	Wickes	1918		
		29	DD76	Philip	1918		
		30	DD78	Evans	1918		

31	DD79	Little	1918
32	DD80	Kimberly	1918
33	DD81	Sigourney	1918
34	DD82	Gregory	1918
35	DD83	Stringham	1918
36	DD84	Dyer	1918
37	DD85	Colhoun	1918
38	DD86	Stevens	1918
39	DD87	McKee	1918
40	DD88	Robinson	1918
41	DD89	Ringgold	1918
42	DD90	McKean	1919
43	DD91	Harding	1919
44	DD92	Gridley	1919
45	DD93	Fairfax	1918
46	DD94	Taylor	1918
47	DD95	Bell	1918
48	DD103	Schley	1918
49	DD104	Champlin	1918
50	DD105	Mugford	1918
51	DD106	Chew	1918
52	DD107	Hazelwood	1919
53	DD108	Williams	1919
54	DD109	Crane	1919
55	DD113	Rathburne	1918
56	DD114	Talbot	1918
57	DD115	Waters	1918
58	DD116	Dent	1918
59	DD117	Dorsey	1918
60	DD118	Lea	1918
61	DD119	Lamberton	1918
62	DD120	Radford	1918
63	DD121	Montgomery	1918
64	DD122	Breese	1918
65	DD123	Gamble	1918
66	DD124	Ramsay	1919
67	DD125	Tattnall	1919
68	DD126	Badger	1919
69	DD127	Twiggs	1919
70	DD128	Babbitt	1919

Wickes

95

71	DD130	Jacob Jones	1919
72	DD131	Buchanan	1919
73	DD132	Aaron Ward	1919
74	DD133	Hale	1919
75	DD134	Crowninshield	1919
76	DD135	Tillman	1920
77	DD136	Boggs	1918
78	DD137	Kilty	1918
79	DD138	Kennison	1919
80	DD139	Ward	1919
81	DD140	Claxton	1919
82	DD141	Hamilton	1919
83	DD142	Tarbell	1918
84	DD143	Yarnall	1918
85	DD144	Upshur	1918
86	DD145	Greer	1918
87	DD146	Elliot	1919
88	DD147	Roper	1919
89	DD148	Breckinridge	1919
90	DD149	Barney	1919
91	DD150	Blakeley	1919
92	DD151	Biddle	1919
93	DD152	Du Pont	1919
94	DD153	Bernadou	1919
95	DD154	Ellis	1919
96	DD155	Cole	1919
97	DD156	J. Fred Talbot	1919
98	DD157	Dickerson	1919
99	DD158	Leary	1919
100	DD159	Schenk	1919
101	DD160	Herbert	1919
102	DD161	Palmer	1918
103	DD162	Thatcher	1919
104	DD163	Walker	1919
105	DD164	Crosby	1919
106	DD165	Meredith	1919
107	DD166	Bush	1919
108	DD167	Cowell	1919
109	DD168	Maddox	1919
110	DD169	Foote	1919

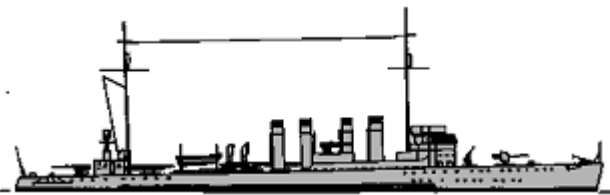

1247t, 95.8x9.4x2.8m, 4b, 2t/1t(2), 27000(75, 76, 78-95, 103-109, 113-124, 131-156, 161-170, 175-185)-24900(125-128, 130)-26000(157-160)hp, 35kts, 114p; 4x1-102/50, 2x1-76/23, 4x3-533TT, 1DCT, 2DCR

111	DD170	Kalk	1919
112	DD175	Mackenzie	1919
113	DD176	Renshaw	1919
114	DD177	O`Bannon	1919
115	DD178	Hogan	1919
116	DD179	Howard	1920
117	DD180	Stansbury	1920
118	DD181	Hopewell	1919
119	DD182	Thomas	1919
120	DD183	Haraden	1919
121	DD184	Abbot	1919
122	DD185	Bagley	1919
123	DD186	Clemson	1919
124	DD187	Dahlgren	1920
125	DD188	Goldsborough	1920
126	DD189	Semmes	1920
127	DD190	Satterlee	1920
128	DD191	Mason	1920
129	DD193	Abel P. Upshur	1920
130	DD194	Hunt	1920
131	DD195	Welborn C. Wood	1921
132	DD196	George E. Badger	1920
133	DD197	Branch	1920
134	DD198	Herndon	1920
135	DD199	Dallas	1920
136	DD206	Chandler	1919
137	DD207	Southard	1919
138	DD208	Hovey	1919
139	DD209	Long	1919
140	DD210	Broome	1919
141	DD211	Alden	1919
142	DD212	Smith Thompson	1919
143	DD213	Barker	1919
144	DD214	Tracy	1920
145	DD215	Borie	1920
146	DD216	John D. Edwards	1920
147	DD217	Whipple	1920

DD

148	DD218	Parrott	1920
149	DD219	Edsall	1920
150	DD220	MacLeish	1920
151	DD221	Simpson	1920
152	DD222	Bulmer	1920
153	DD223	McCormick	1920
154	DD224	Stewart	1920
155	DD225	Pope	1920
156	DD226	Peary	1920
157	DD227	Pillsbury	1920
158	DD228	John D. Ford	1920
159	DD229	Truxtun	1921
160	DD230	Paul Jones	1921
161	DD231	Hatfield	1920
162	DD232	Brooks	1920
163	DD233	Gilmer	1920
164	DD234	Fox	1920
165	DD235	Kane	1920
166	DD236	Humphreys	1920
167	DD237	McFarland	1920
168	DD238	James K. Paulding	1920
169	DD239	Overton	1920
170	DD240	Sturtevant	1920
171	DD241	Childs	1920
172	DD242	King	1920
173	DD243	Sands	1920
174	DD244	Williamson	1920
175	DD245	Reuben James	1920
176	DD246	Bainbridge	1921
177	DD247	Goff	1921
178	DD248	Barry	1920
179	DD249	Hopkins	1921
180	DD250	Lawrence	1921
181	DD251	Belknap	1919
182	DD252	McCook	1919
183	DD253	McCalla	1919
184	DD254	Rodgers	1919
185	DD255	Osmond Ingram	1919

Clemson 149

186	DD256	Bancroft	1919
187	DD257	Welles	1919
188	DD258	Aulick	1919
189	DD259	Turner	1919
190	DD260	Gillis	1919
191	DD262	McDermut	1919
192	DD263	Laub	1919
193	DD264	McLanahan	1919
194	DD265	Edwards	1919
195	DD266	Greene	1919
196	DD267	Ballard	1919
197	DD268	Shubrick	1919
198	DD269	Bailey	1919
199	DD270	Thornton	1919
200	DD271	Morris	1919
201	DD272	Tingey	1919
202	DD273	Swasey	1919
203	DD274	Meade	1919
204	DD275	Sinclair	1919
205	DD276	McCawley	1919
206	DD277	Moody	1919
207	DD278	Henshaw	1919
208	DD279	Meyer	1919
209	DD280	Doyen	1919
210	DD281	Sharkey	1919
211	DD282	Toucey	1919
212	DD283	Breck	1919
213	DD284	Isherwood	1919
214	DD285	Case	1919
215	DD286	Lardner	1919
216	DD287	Putnam	1919
217	DD288	Worden	1920
218	DD289	Flusser	1920
219	DD290	Dale	1920
220	DD291	Converse	1920
221	DD292	Reid	1919
222	DD293	Billingsley	1920
223	DD294	Charles Ausburn	1920
224	DD295	Osborne	1920
225	DD298	Percival	1920

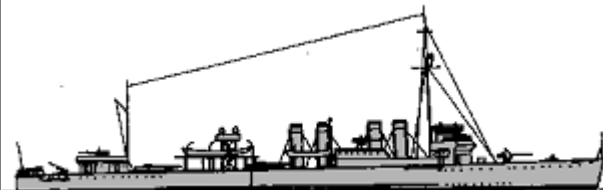





1308t, 95.8x9.4x3.0m, 4b, 2gt, 27000hp, 35kts, 114p; 4x1-102/50(186-191, 193-199, 206, 207, 210-230, 236-260, 262-295, 298-308, 313-347), 4x2-102/50(208, 209), 4x1-127/51(231-235), 2x1-76/23, 4x3-533TT, 1DCT, 2DCR

226	DD299	John Francis Burnes	1920
227	DD300	Farragut	1920
228	DD301	Somers	1920
229	DD302	Stoddert	1920
230	DD303	Reno	1920
231	DD304	Farquhar	1920
232	DD305	Thompson	1920
233	DD306	Kennedy	1920
234	DD307	Paul Hamilton	1920
235	DD308	William Jones	1920
236	DD313	Zeilin	1920
237	DD314	Yarborough	1920
238	DD315	La Vallette	1920
239	DD316	Sloat	1920
240	DD317	Wood	1921
241	DD318	Shirk	1921
242	DD319	Kidder	1921
243	DD320	Selfridge	1921
244	DD321	Marcus	1921
245	DD322	Mervine	1921
246	DD323	Chase	1921
247	DD324	Robert Smith	1921
248	DD325	Mullany	1921
249	DD326	Coghlan	1921
250	DD327	Preston	1921
251	DD328	Lamson	1921
252	DD329	Bruce	1921
253	DD330	Hull	1921
254	DD331	MacDonough	1921
255	DD332	Farenholt	1921
256	DD333	Sumner	1921
257	DD334	Corry	1921
258	DD335	Melvin	1921
259	DD336	Litchfield	1920
260	DD337	Zane	1921
261	DD338	Wasmuth	1921
262	DD339	Trever	1922
263	DD340	Perry	1922
264	DD341	Decatur	1922
265	DD342	Hulbert	1920











266	DD343	Noa	1921
267	DD344	William B. Preston	1920
268	DD345	Preble	1920
269	DD346	Sicard	1920
270	DD347	Pruitt	1920

## SUBMARINES

H	8	1	SS29	H2	1913		358/467t, 45.8x4.8x3.8m, 2d/em, 950/600hp, 14/10.5kts, 25p, 60m; 4-450TT
		2	SS30	H3	1914		
		3	SS147	H4	1918		
		4	SS148	H5	1918		
		5	SS149	H6	1918		
		6	SS150	H7	1918		
		7	SS151	H8	1918		
		8	SS152	H9	1918		
K	8	9	SS32	K1	1914		392/521t, 46.9x5.1x4.0m, 2d/em, 950/680hp, 14/10.5kts, 28p, 60m; 4-450TT
		10	SS33	K2	1914		
		11	SS34	K3	1914		
		12	SS35	K4	1914		
		13	SS36	K5	1914		
		14	SS37	K6	1914		
		15	SS38	K7	1914		
		16	SS39	K8	1914		
L	4	17	SS41	L2	1916		450/548t, 51.0x5.3x4.1m, 2d/em, 1200/800hp, 14/10.5kts, 28p, 60m; 4-450TT
		18	SS42	L3	1916		
		19	SS49	L9	1916		
		20	SS51	L11	1916		
N	3	21	SS53	N1	1917		348/414t, 44.9x4.8x3.8m, 2d/em, 600/300hp, 13/11kts, 25p, 60m; 4-450TT
		22	SS54	N2	1917		
		23	SS55	N3	1917		
O	15	24	SS62	O1	1918		521/629(62-65, 67-71)-491/566(72-77)t, 52.5(62-65, 67-71)-52.4(72-77)x5.5(62-65, 67-71)-5.1(72-77)x4.4(62-65, 67-71)-4.2(72-77)m, 2d/em, 600/550(62-65, 67-71)-880/740(72-77)hp, 13/11(62-65, 67-71)-14/10.5(72-77)kts, 25(62-65, 67-71)-29(72-77)p, 60m; 1x1-76/23, 4-450TT
		25	SS63	O2	1918		
		26	SS64	O3	1918		
		27	SS65	O4	1918		
		28	SS67	O6	1918		
		29	SS68	O7	1918		
		30	SS69	O8	1918		
		31	SS70	O9	1918		
32	SS71	O10	1918				

		33	SS72	O11	1918		
		34	SS73	O12	1918		
		35	SS74	O13	1918		
		36	SS75	O14	1918		
		37	SS76	O15	1918		
		38	SS77	O16	1918		
		39	SS78	R1	1918		
		40	SS79	R2	1919		
		41	SS80	R3	1919		
		42	SS81	R4	1919		
		43	SS82	R5	1919		
		44	SS83	R6	1919		
		45	SS84	R7	1919		
		46	SS85	R8	1919		
		47	SS86	R9	1919		
		48	SS87	R10	1919		
		49	SS88	R11	1919		
		50	SS89	R12	1919		
		51	SS90	R13	1919		
R	27	52	SS91	R14	1919		569/680(78-97)-510/583(98-104)t, 56.8(78-97)-53.3(98-104)x5.5(78-97)-5.1(98-104)x4.4m, 2d/em, 1200/940(78-97)-1000/800(98-104)hp, 13.5/11(78-97)-14/11(98-104)kts, 29p, 60m; 1x1-76/50, 4-533TT(78-97), 4-450TT(98-104)
		53	SS92	R15	1918		
		54	SS93	R16	1918		
		55	SS94	R17	1918		
		56	SS95	R18	1918		
		57	SS96	R19	1918		
		58	SS97	R20	1918		
		59	SS98	R21	1919		
		60	SS99	R22	1919		
		61	SS100	R23	1919		
		62	SS101	R24	1919		
SS		63	SS102	R25	1919		
		64	SS103	R26	1919		
		65	SS104	R27	1919		
		66	SS105	S1	1920		
		67	SS123	S18	1924		
		68	SS124	S19	1921		
		69	SS125	S20	1922		
		70	SS126	S21	1921		
		71	SS127	S22	1924		
		72	SS128	S23	1923		
		73	SS129	S24	1923		

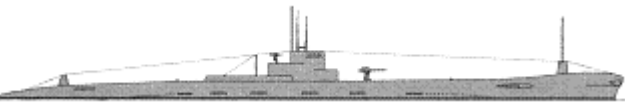
SI	25	74	SS130	S25	1923		854/1062t, 66.9x6.3x4.8m, 2d/em, 1200/1500hp, 14/11kts, 38p, 60m; 1x1-102/50, 4-533TT
		75	SS131	S26	1923		
		76	SS132	S27	1924		
		77	SS133	S28	1923		
		78	SS134	S29	1924		
		79	SS135	S30	1920		
		80	SS136	S31	1922		
		81	SS137	S32	1922		
		82	SS138	S33	1922		
		83	SS139	S34	1922		
		84	SS140	S35	1922		
		85	SS141	S36	1923		
		86	SS142	S37	1923		
		87	SS143	S38	1923		
SII	1	91	SS106	S2	1920		800/977t, 63.1x6.0x4.9m, 2d/em, 1800/1200hp, 15/11kts, 38p, 60m; 1x1-102/50, 4-533TT
		92	SS107	S3	1919		875/1088(107)-876/1092(109, 111-122)t, 70.4x6.7x4.0m, 2d/em, 1400/1200(107)-2000/1200(109, 111-122)hp, 15/11kts, 38p, 60m; 1x1-102/50, 5-533TT(107, 109, 111-118), 4-533TT(119-122)
93	SS109	S4	1919				
94	SS111	S6	1920				
95	SS112	S7	1920				
96	SS113	S8	1920				
97	SS114	S9	1921				
98	SS115	S10	1922				
99	SS116	S11	1923				
100	SS117	S12	1923				
101	SS118	S13	1923				
102	SS119	S14	1921				
103	SS120	S15	1921				
104	SS121	S16	1920				
105	SS122	S17	1921				
SIV	6	106	SS153	S42	1924		906/1126t, 68.7x6.3x4.9m, 2d/em, 1200/1200hp, 14.5/11kts, 38p, 60m; 1x1-102/50, 4-533TT
		107	SS154	S43	1924		
		108	SS155	S44	1925		
		109	SS156	S45	1925		
		110	SS157	S46	1925		
		111	SS158	S47	1925		
		112	SS159	S48	1922		

SV	3	113	SS160	S49	1922		903/1230t, 73.2x6.6x4.1m, 2d/em, 1800/1500hp, 14.5/11kts, 38p, 60m; 1x1-102/50, 5-533TT
		114	SS161	S50	1922		
T	3	115	SF1	T1	1920		1107/1482t, 82.0x7.0x4.3m, 2d/em, 4000/1350hp, 20/10.5kts, 38p, 45m; 2x1-76/23, 6-533TT
		116	SF2	T2	1922		
		117	SF3	T3	1920		
V1	3	118	SF4	V1	1924		2119/2506t, 102.0x8.4x4.6m, 2d+2dg/em(2), 6200/2400hp, 18.7/9kts, 85p, 60m; 1x1-76/50, 6-533TT
		119	SF5	V2	1925		
		120	SF6	V3	1926		
V4	1	121	SF7	V4	1928		2878/4045t, 116.1x10.3x4.9m, 2d+2dg/em(2), 3175/2200hp, 13.6/7.4kts, 86p, 95m; 2x1-152/53, 4-533TT, 60mines

## ESCORTS

PC	Eagle	52	1	PE1	Eagle-1	1918		615t, 61.2x10.1x2.6m, 2b, 1gt, 2500hp, 18.3kts, 61p; 2x1-102/50, 1x1-76/50, 1DCT
			2	PE2	Eagle-2	1918		
			3	PE3	Eagle-3	1918		
			4	PE4	Eagle-4	1918		
			5	PE5	Eagle-5	1918		
			6	PE6	Eagle-6	1918		
			7	PE7	Eagle-7	1918		
			8	PE8	Eagle-8	1919		
			9	PE9	Eagle-9	1919		
			10	PE10	Eagle-10	1919		
			11	PE11	Eagle-11	1919		
			12	PE12	Eagle-12	1919		
			13	PE13	Eagle-13	1919		
			14	PE14	Eagle-14	1919		
			15	PE15	Eagle-15	1919		
			16	PE18	Eagle-18	1919		
			17	PE19	Eagle-19	1919		
			18	PE23	Eagle-23	1919		
			19	PE24	Eagle-24	1919		
			20	PE26	Eagle-26	1919		
			21	PE27	Eagle-27	1919		
			22	PE28	Eagle-28	1919		
			23	PE29	Eagle-29	1919		
			24	PE32	Eagle-32	1919		
			25	PE33	Eagle-33	1919		
			26	PE34	Eagle-34	1919		

27	PE35	Eagle-35	1919
28	PE36	Eagle-36	1919
29	PE37	Eagle-37	1919
30	PE38	Eagle-38	1919
31	PE39	Eagle-39	1919
32	PE40	Eagle-40	1919
33	PE41	Eagle-41	1919
34	PE42	Eagle-42	1919
35	PE43	Eagle-43	1919
36	PE44	Eagle-44	1919
37	PE45	Eagle-45	1919
38	PE46	Eagle-46	1919
39	PE47	Eagle-47	1919
40	PE48	Eagle-48	1919
41	PE49	Eagle-49	1919
42	PE50	Eagle-50	1919
43	PE51	Eagle-51	1919
44	PE52	Eagle-52	1919
45	PE53	Eagle-53	1919
46	PE54	Eagle-54	1919
47	PE55	Eagle-55	1919
48	PE56	Eagle-56	1919
49	PE57	Eagle-57	1919
50	PE58	Eagle-58	1919
51	PE59	Eagle-59	1919
52	PE60	Eagle-60	1919



PY	-	5	1	PY1	Mayflower	1896		2690t, 83.2x11.0xm, 2vte, 17kts; 6x1-57/40
			2	PY6	Nokomis	1914		1265t, 74.1x9.7xm, 16kts; 4x1-76/50
			3	PY7	Aramis	1916		375t
			4	PY9	Niagara	1898		2690t, 86.0x13.1xm, 12kts; 4x1-102/40, 1DCT
			5	PY10	Isabel	1917		710t

OTHER FIGHTING SHIPS

Wilmington	2	1	PG8	Wilmington	1897		1689t, 76.4x12.5x2.7m, 6b, 2vte, 15kts, 183-199p; 25belt, 38deck; 8x1-102/40
		2	PG9	Helena	1897		

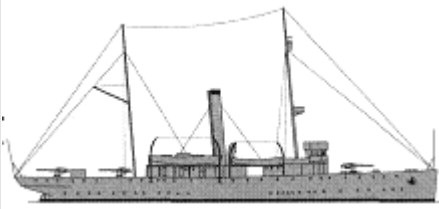
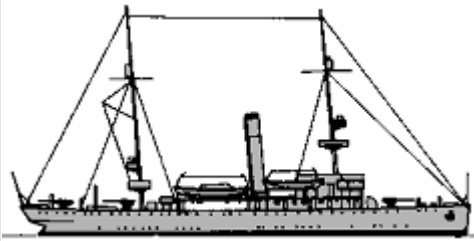
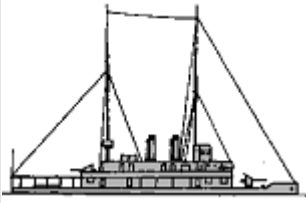
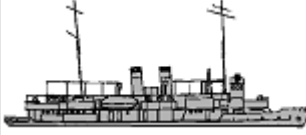
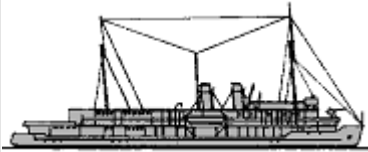
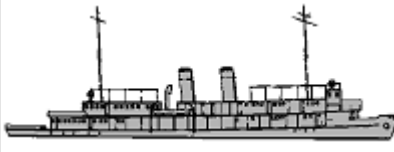
PG	Sacramento	1	3	PG19	Sacramento	1914		1592t, 69.0x12.5x3.5m, 2b, 1vte, 12.5kts, 163p; 3x1-102/50
	Asheville	2	5	PG22	Tulsa	1923		1760t, 73.5x12.6x3.4m, 3b, 1gt, 850hp, 12kts, 159p; 3x1-102/50
PR	Palos	2	1	PR1	Palos	1914		204t, 48.8x7.5x0.7m, 2b, 2vte, 800hp, 13.3kts, 47p; 2x1-57/40
			2	PR2	Monocacy	1914		
	Guam	2	3	PR3	Guam	1927		395t, 48.6x8.3x1.6m, 2b, 2vte, 1950hp, 14.5kts, 70p; 2x1-76/50
			4	PR4	Tutuila	1928		
	Panay	2	5	PR5	Panay	1928		474t, 58.2x8.6x1.6m, 2b, 2vte, 2250hp, 15kts, 70p; 2x1-76/50
			6	PR6	Oahu	1928		
Luzon	2	7	PR7	Luzon	1928		620t, 64.2x9.5x1.7m, 2b, 2vte, 3150hp, 16kts, 70p; 2x1-76/50	
		8	PR8	Mindanao	1928			

COASTAL FORCES

PS	SC1	23	1 - 23	SC2, 57, 63, 64, 102, 143, 185, 192, 210, 224, 252, 271, 306, 326, 328, 330, 353, 412, 431 - 433, 437, 440	1917 - 1919		85t, 33.5x4.5x1.7m, 3pe, 660hp, 18kts, 27p; 1x1-76/23, 1DCT
----	-----	----	--------	--	-------------	---	---

MINE WARFARE

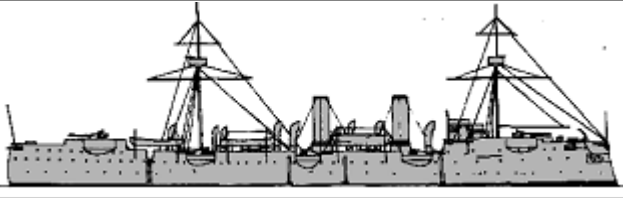
	Baltimore	1	1	CM1	Baltimore	1890		5436t, 102.1x14.8x5.9m, 8b, 2hte, 10750hp, 19kts, 386p; S64/102deck, 76CT; 4x1-127/51, 2x1-76/50, 180mines
--	-----------	---	---	-----	-----------	------	--	--

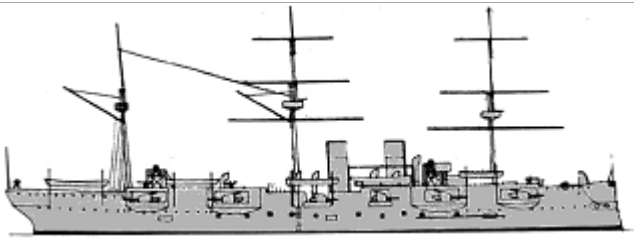
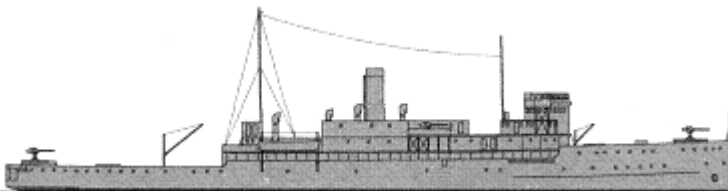
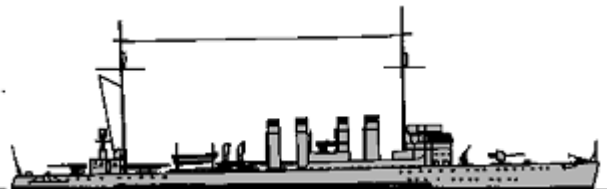

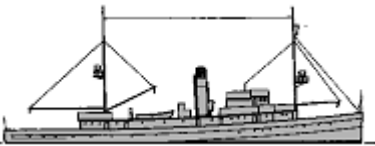
ML	San Francisco	1	2	CM2	Tahoe	1890		4583t, 98.9x15.0x5.7m, 8b, 2hte, 10500hp, 19kts, 384p; S51/76deck, 76CT; 4x1-127/51, 180mines
	Aroostook	2	3	CM3	Aroostook	1907		4200t, 120.4x15.9x4.9m, 8b, 2vte, 7000hp, 20kts, 314p; 1x1-127/51, 2x1-76/50, 300mines
			4	CM4	Oglala	1907		
	Stribling	14	5	DM1	Stribling	1918		1247t, 95.8x9.4x2.8m, 4b, 2t/1t(2), 27000hp, 35kts, 114p; 4x1-102/50, 2DCR, 80mines
			6	DM2	Murray	1918		
			7	DM3	Israel	1918		
			8	DM4	Luce	1918		
			9	DM5	Maury	1918		
			10	DM6	Lansdale	1918		
			11	DM7	Mahan	1918		
			12	DM8	Hart	1919		
			13	DM9	Ingraham	1919		
			14	DM10	Ludlow	1918		
			15	DM11	Burns	1919		
16			DM12	Anthony	1919			
17			DM13	Sproston	1919			
18			DM14	Rizal	1919			
			1	AM1	Lapwing	1918		
			2	AM2	Owl	1918		
			3	AM3	Robin	1918		
			4	AM4	Swallow	1918		
			5	AM5	Tanager	1918		
			6	AM7	Oriole	1918		
			7	AM9	Finch	1918		
			8	AM10	Heron	1918		
			9	AM13	Turkey	1918		
			10	AM14	Woodcock	1919		
			11	AM15	Quail	1919		
			12	AM16	Partridge	1919		
			13	AM17	Eider	1919		
			14	AM18	Thrush	1919		
			15	AM19	Avocet	1919		
			16	AM20	Bobolink	1919		

MS	Bird	37	17	AM21	Lark	1919		1400t, 57.6x10.8x3.8m, 2b, 1vte, 1400hp, 13.5kts, 85p; 2x1-76/50, mines, MS
			18	AM23	Teal	1918		
			19	AM24	Brant	1918		
			20	AM25	Kingfisher	1918		
			21	AM26	Rail	1918		
			22	AM27	Pelican	1918		
			23	AM30	Seagull	1919		
			24	AM31	Tern	1919		
			25	AM33	Penguin	1919		
			26	AM34	Swan	1919		
			27	AM35	Whippoorwill	1919		
			28	AM36	Bittern	1919		
			29	AM37	Sanderling	1918		
			30	AM40	Cormorant	1919		
			31	AM41	Gannet	1919		
			32	AM43	Grebe	1919		
			33	AM46	Peacock	1919		
34	AM51	Sandpiper	1919					
35	AM52	Vireo	1919					
36	AM53	Warbler	1919					
37	AM54	Willet	1920					

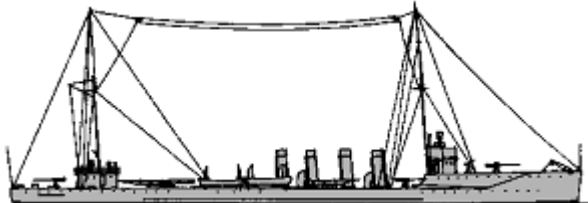
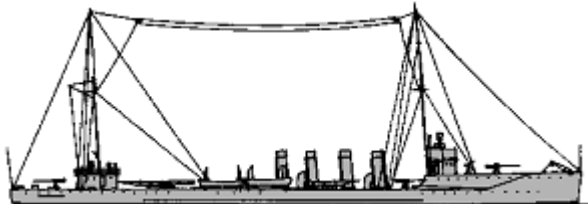
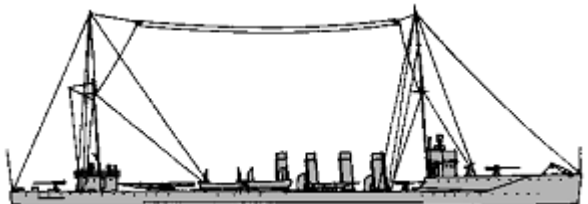

COAST GUARD

WDD	Cassin	3	1	CG1	Cassin	1913		1235t, 93.1x9.2x3.0m, 4b, 2t/1vte(2)(1, 3)-2t/vte(4), 16000hp, 29kts, 98p; 3x1-102/50(1, 3), 4x1-102/50(4), 4x2-450TT, 1DCT, 2DCR	
			2	CG3	Cummings	1913			
			3	CG4	Downes	1915			
	Tucker	4	4	CG2	Conyngham	1916		1205t, 96.1x9.3(2, 7)-9.1(23, 24)x2.9m, 4b, 2t/1t(2), 18000(2, 7)-17000(23, 24)hp, 29.5kts, 99p; 4x1-102/50, 4x2-533TT, 2DCR	
			5	CG7	Porter	1916			
			6	CG23	Tucker	1916			
	O'Brien	2	7	CG24	Wainwright	1916		1171t, 93.1x9.5x2.9m, 4b, 2t/1vte(2), 17000hp, 29kts, 101p; 4x1-102/50, 4x2-533TT, 1DCT, 2DCR	
			8	CG5	Ericsson	1915			
				9	CG6	McDougal	1914		
				10	CG8	Ammen	1911		

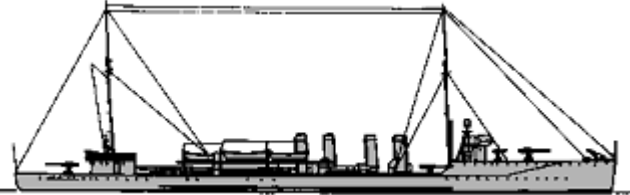

WPS	Monaghan	8	11	CG9	Beale	1912		883t, 89.5x8.2x2.5m, 4b, 3t, 12000(8, 9, 11, 13, 15, 16, 20)-13000(12)hp, 29.5(8, 9, 11, 13, 15, 16, 20)-30(12)kts, 89p; 5x1-76/50(8, 11-13, 15, 16, 20), 4x1-76/50(9), 3x2-450TT, 1DCT, 2DCR	
			12	CG11	Fanning	1912			
			13	CG12	Henley	1912			
			14	CG13	Jouett	1912			
			15	CG15	Monaghan	1911			
			16	CG16	Patterson	1911			
			17	CG20	Trippe	1911			
			18	CG10	Burrows	1911			
	Paulding	5	19	CG14	McCall	1911		887t, 89.6x8.0x2.4m, 4b, 3t, 12000hp, 29.5kts, 86p; 5x1-76/50, 3x2-450TT, 1DCT, 2DCR	
			20	CG17	Paulding	1910			
			21	CG18	Roe	1910			
			22	CG19	Terry	1910			
			23	CG21	Davis	1916			
	Sampson	3	24	CG22	Shaw	1917		1225t, 96.1x9.1x2.9m, 4b, 2t/1t(2)(21)-2t/t(22, 25), 17500hp, 29.5kts, 99p; 4x1-102/50, 4x3-533TT, 1DCT, 2DCR	
			25	CG25	Wilkes	1916			
		Galveston	1	1	-	Apache	1891	No picture	708t, 57.9x8.8x2.8m, 2b, 1vte, 1200hp, 12kts, 41p; 3x1-76/50
		William Windom	1	2	-	Comanche	1896	No picture	670t, 52.0x8.2x2.9m, 2b, 2vte, 800hp, 15kts, 49p; 1x1-76/50, 2x1-57/40
		Gresham	3	3	WPG1	Gresham	1897	No picture	1190t, 62.6x9.8x3.4m, 4b(1)-2b(2, 4), 1vte, 2500hp, 17kts, 73p; 4x1-76/50(1, 4), 4x1-102/50(2)
	4			WPG2	Manning	1898			
	5			WPG4	Algonquin	1898			
		Seminole	1	6	WPG6	Seminole	1900	No picture	860t, 57.3x8.8x3.4m, 2b, 1vte, 14.7kts, 67p; 4x1-76/50
		Tuscarora	1	7	WPG7	Tuscarora	1902	No picture	739t, 54.3x9.1x3.4m, 2b, 1vte, 14.2kts, 65p; 1x1-76/50, 2x1-57/40
		Pamlico	1	8	WPG15	Pamlico	1907	No picture	455t, 48.2x9.1x1.7m, 1b, 2vte, 600hp, 9.8kts, 33p; 2x1-57/40
		Snohomish	2	9	WPG16	Snohomish	1908	No picture	879t, 46.3x8.8x4.2m, 2b, 1vte, 1200hp, 12kts, 53p; 1x1-76/50, 2x1-57/40
	10			WPG18	Acushnet	1908			
	Seneca	1	11	WPG17	Seneca	1908	No picture	1445t, 62.2x10.4x5.2m, 2b, 1vte, 1500hp, 12.5kts, 74p; 4x1-102/50	
	Tahoma	1	12	WPG21	Yamacraw	1909	No picture	1082t, 58.2x9.8x4.3m, 1vte, 14.1kts, 69p; 2x1-76/50	
	Ossipee	2	13	WPG26	Ossipee	1915	No picture	997t, 50.5x9.8x3.6m, 2b, 1vte, 1000hp, 12.7kts, 72p; 2x1-57/40, 1DCT	
			14	WPG27	Tallapoosa	1915			
	Haida	4	15	WPG45	Haida	1921	No picture	1955t, 73.2x11.9x5.0m, 2b, 1tg, 1em, 2600hp, 15kts, 122p; 2x1-127/51, 1x1-76/50(46), 2x1-57/40(45, 47, 48), 2x1-57/40(46), 1x1-37/40(45, 47, 48)	
			16	WPG46	Modoc	1922			
			17	WPG47	Mojave	1921			
			18	WPG48	Tampa	1921			
	Lake	5	19	WPG45	Chelan	1928		2075t, 76.2x12.8x3.9m, 2b, 1tg, 1em, 3350hp, 17kts, 97p; 1x1-127/51, 1x1-76/50, 2x1-57/40	
			20	WPG46	Pontchartrain	1928			
			21	WPG47	Tahoe	1928			

		22	WPG48	Champlain	1929				
		23	WPG49	Mendota	1929				
	Northland	1	24	WPG49	Northland	1927		2150t, 66.0x11.9x4.2m, 2dg, 1em, 1000hp, 11.5kts, 107p; 2x1-57/40, 1x1-37/40, 1seaplane (1 O2U)	
	Miami	1	25	WPG53	Unalga	1912	No picture	1181t, 57.9x9.9x4.3m, 1vte, 1300hp, 13kts; 2x1-102/50, 2x1-76/50, 2DCR	
WPC	Corwin	13	1		Corwin	1925	No picture	210t, 30.4x7.0x1.4m, 2d, 300hp, 12kts, 15p; 1x1-76/23	
			2		Dallas	1925			
			3		Dexter	1925			
			4		Eagle	1925			
			5		Forward	1925			
			6		Gallatin	1926			
			7		Mahoning	1926			
			8		Nansemond	1926			
			9		Naugatuck	1926			
			10		Patriot	1926			
			11		Perry	1926			
			12		Petrel	1926			
			13		Wolcott	1926			
		Active	32	14	WPC125	Active	1927	No picture	289t, 38.1x7.1x2.1m, 2d, 600hp, 13.3kts, 38p; 1x1-76/23
	15			WPC126	Agassiz	1927			
	16			WPC127	Alert	1927			
	17			WPV128	Antietam	1927			
	18			WPC129	Bonham	1927			
	19			WPC130	Boutwell	1927			
	20			WPC131	Cahoone	1927			
	21			WPC132	Cartigan	1927			
	22			WPC133	Montgomery	1927			
	23			WPC134	Crawford	1927			
	24			WPC135	Diligence	1927			
	25			WPC136	Dix	1927			
	26			WPC137	Ewing	1927			
	27			WPC138	Faunce	1927			
	28			WPC139	Frederick Lee	1927			
	29			WPC140	General Greene	1927			
	30			WPC141	Harriet Lane	1927			

			31	WPC142	Jackson	1927		
			32	WPC143	Kimball	1927		
			33	WPC144	Legare	1927		
			34	WPC145	Marion	1927		
			35	WPC146	McLane	1927		
			36	WPC147	Morris	1927		
			37	WPC148	Nemaha	1927		
			38	WPC149	Pulaski	1927		
			39	WPC150	Reliance	1927		
			40	WPC151	Rush	1927		
			41	WPC152	Tiger	1927		
			42	WPC153	Travis	1927		
			43	WPC154	Vigilant	1927		
			44	WPC155	Woodbury	1927		
			45	WPC156	Yeaton	1927		
	SC1	8	46 - 53	WSC155, 183, 229, 231, 238, 258, 335, 438	Smith, Tingard, Boone, Blaze, Bowstring, Belleville, Cygan, Cook	1917 - 1919		85t, 33.5x4.5x1.7m, 3pe, 660hp, 18kts, 27p; 1x1-76/23, 1DCT
WYP	CG100	203	1 - 203	CG100 - 302	-	1924 - 1926	No picture	37t, 22.9x4.2x1.2m, 1pe, 400hp, 13kts; 1x1-37/43

NAVAL AVIATION (approximately, maximal number of delivered planes signed)

Deck planes	F: 10 FB-1, 27 FB-5, 35 F6C-3 Hawk, 31 F6C-4 Hawk, 74 F3B-1, 33 F2B-1, 27 F4B-1 (delivery till 1930); FB: 21 F8C-3 Falcon; TB: 24 T3M-1, 100 T3M-2, 102 T4M-1 (delivery till 12/1931), 50 TG-1 and TG-2 (delivery till 12/1931), 12 T2D-1 (delivery till 6/1932); R: 17 VE-9, 20 OL-8A, some O2U-1, some O2U-2, some O2U-3, some O2U-4 (delivery till 2/1930)
Seaplanes	R: 28 OL-6, 20 OL-8 (delivery till 1930), 130 O2U-1 (inc deck planes), 37 O2U-2 (inc deck planes), 80 O2U-3 (inc deck planes), 42 O2U-4 (inc deck planes, delivery till 2/1930)

[home](#)

[World navies yesterday](#)

[1930](#)

## Uruguay 01 January 1930

### CRUISERS

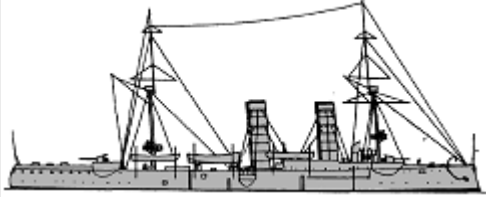
CL	Montevideo	1	1	Montevideo	1887		2050t, 76.2x11.3x4.4m, 4b,2vte, 5012hp, 17.7kts, 250p; compound: 51deck, 114shields, 51CT; 6x1-152/40, 9x1-57/40, 4-450TT
----	------------	---	---	------------	------	--	---

### TORPEDO SHIPS

PGT	Uruguay	1	1	Uruguay	1910		1400t, 85.0ppx9.4x3.6m, 4b,2vte, 5700hp, 23kts, 125p; steel: 17deck; 2x1-120/45, 4x1-76/40, 6x1-37/43, 2x1-450TT
-----	---------	---	---	---------	------	--	--

© Ivan Gogin, 2011-15

[home](#)[World navies yesterday](#)[1930](#)

## Venezuela 01 January 1930

### OTHER FIGHTING SHIPS

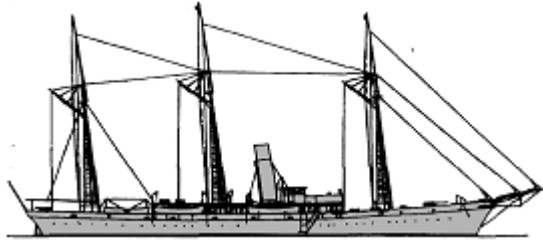
PG	Miranda	1	1	Miranda	1895	No picture	200t, 41.5x5.8x2.5m, 1b,1vte, 315hp, 10kts, 55p; 4x1-57/43
APG	-	3	1	General Salóm	1884		750t; 1x1-76/40
			2	Jose Felix Ribas	1894		300t
			3	Aragua			154t

© Ivan Gogin, 2011-15

[home](#)[World navies yesterday](#)[1930](#)

# Yugoslavia 01 January 1930

*IN SERVICE: 1 protected cruiser, 8 torpedo boats, 4 submarines, 4 river monitors, 2 motor torpedo boats, 7 minesweepers*



*IN CONSTRUCTION: 1 seaplane tender, 2 river patrol launches*

*IN SERVICE*

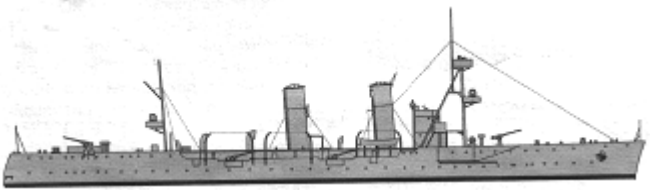
## CRUISERS

CL	Dalmacija	1	1	Dalmacija	1900		2953t, 105.0x12.2x5.2m, 8b,2vte, 8110hp, 16kts, 300p; 25deck, 50slopes, 80CT; 6x1-83/55, 4x1-47/44, 2x1-15
----	-----------	---	---	-----------	------	---	--

## TORPEDO SHIPS



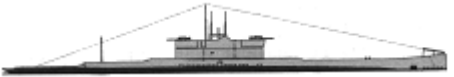

TB	T1	4	1	T1	1914		320t, 58.2x5.7x1.5m, 2b,2t, 5000hp, 28kts, 52p; 2x1-66/50, 2x2-450TT		
			2	T2	1914				
			3	T3	1914				
			4	T4	1914				
	T5	4	5	T5	1915				330t, 58.8x5.8x1.5m, 2b,2t, 5000hp, 28kts, 52p; 2x1-66/50, 2x2-450TT
			6	T6	1916				
			7	T7	1916				
			8	T8	1916				

## SUBMARINES

SS	Hrabri	2	1	Hrabri	1928		975/1164t, 72.1x7.3x4.0m, 2d/em, 2400/1600hp, 15.7/10kts, 47p, 50m; 2x1-102/40, 6-533TT
			2	Nebojša	1928		
			3	Smeli	1929		

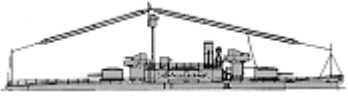
	Smeli	2	4	Osvetnik	1929		655/822t, 69.1x5.4x3.8m, 2d/em, 1480/1100hp, 14.5/9.2kts, 45p, 80m; 1x1-100/40, 6-550TT
--	-------	---	---	----------	------	---	---

## OTHER FIGHTING SHIPS

RMON	Morava	1	1	Morava	1892		448t, 54.0x9.0x1.2m, 2b,2vte, 1200hp, 10kts, 84p; 50belt, 19deck, 75CT; 2x1-120/35, 1x1-66/42, 1x1-15
	Sava	1	2	Sava	1904		470t, 57.7x9.5x1.2m, 2b,2vte, 1400hp, 13kts, 86p; 40belt, 25deck, 75CT; 2x1-120/35, 1x1-120/10, 1x1-66/50
	Drava	1	3	Drava	1914		540t, 57.9x10.3x1.3m, 2b,2vte, 1500hp, 13kts, 95p; 50belt, 19deck, 75CT; 1x2-120/40, 3x1-120/10, 2x1-66/50
	Vardar	1	4	Vardar	1915		580t, 62.0x10.3x1.3m, 2b,2vte, 1750hp, 13.5kts, 91p; 40belt, 25deck, 50CT; 1x2-120/40, 2x1-120/10, 2x1-66/50, 2x1-47/44

## COASTAL FORCES

PT	Uskok	2	1, 2	Uskok, Četnik	1928		15t, 16.8x3.4x1.2m, 2pe, 750hp, 40kts, 5p; 2-450TT
----	-------	---	------	---------------	------	---	--

## MINE WARFARE SHIPS

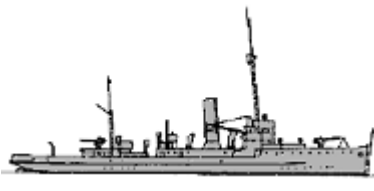
MS	D1	1	1	D2	1888		88t, 39.9x4.8x1.9m, 1b,1vte, 1000hp, 19kts, 16p; 2x1-37/23, MS
	Orao	6	2	Orao	1918		590t, 59.6x7.3x2.2m, 2b,2vte, 1840-1850hp, 16kts, 51p; 2x1-90/45, 24m, MS
			3	Galeb	1918		
			4	Gavran	1919		
			5	Jastreb	1919		
			6	Kobac	1918		
			7	Sokol	1919		

## IN CONSTRUCTION

## AIRCRAFT CARRYING SHIPS

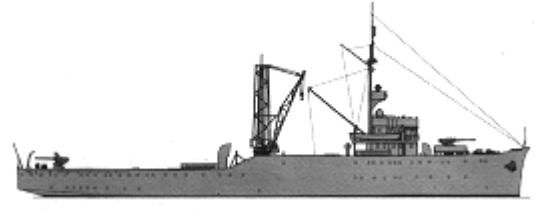
AV	Zmaj	1	1	Zmaj	1930		2084t, 83.0x12.7x3.5m, 2d, 3260hp, 15kts, 145p; 2x1-84/55, 2x2-40/6, 2seaplanes (DH.60)
----	------	---	---	------	------	--	---

## COASTAL FORCES

YPR	Graničar	2	1, 2	Graničar, Stražar	1930	No picture	36t, 18.2x3.0x1.0m, 1d, 120hp, 10.7kts
-----	----------	---	------	-------------------	------	------------	--

© Ivan Gogin, 2011