

[home](#)

# THE NAVAL BALANCE 1925

## Navies of the world

01/01/1925

1. United Kingdom - 1617 tt; 2. USA - 1488 tt; 3. Japan - 760 tt; 4. France - 533 tt; 5. Italy - 321 tt; 6. Soviet Union - 202 tt; 7. Germany - 142 tt; 8. Argentina - 122 tt; 9. Spain - 111 tt

tt - thousand ton



[ARGENTINA](#)

[AUSTRALIA](#)

[AUSTRIA](#)

[BELGIUM](#)

[BRAZIL](#)

[BULGARIA](#)

[CANADA](#)

[CHILE](#)

[CHINA](#)

[COLOMBIA](#)

[CUBA](#)

[CZECHOSLOVAKIA](#)



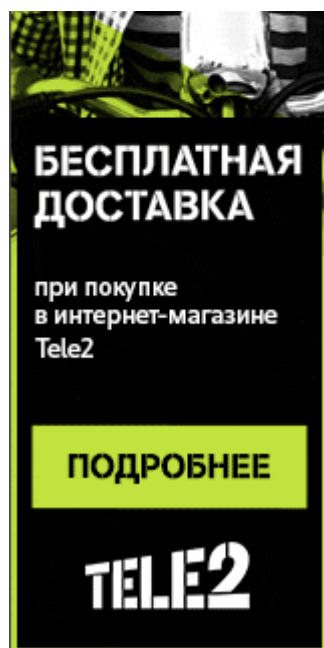

**БЕСПЛАТНАЯ  
ДОСТАВКА**

при покупке  
в интернет-магазине  
Tele2

**ПОДРОБНЕЕ**

**TELE2**

[DENMARK](#)

[ECUADOR](#)

[EGYPT](#)

[ESTONIA](#)

[FINLAND](#)

[FRANCE](#)

[GERMANY](#)

[GREECE](#)

[HUNGARY](#)

[INDIA](#)

[IRELAND](#)

[ITALY](#)

[JAPAN](#)

[LATVIA](#)

[MEXICO](#)

[NETHERLANDS](#)

[NEW ZEALAND](#)

[NORWAY](#)

[PARAGUAY](#)

[PERSIA](#)

[PERU](#)

[POLAND](#)

[PORTUGAL](#)

[ROMANIA](#)

[SIAM](#)

[SOUTH AFRICA](#)

[SOVIET UNION](#)

[SPAIN](#)

[SWEDEN](#)

[TURKEY](#)

[UNITED KINGDOM](#)

[UNITED STATES OF AMERICA](#)

[URUGUAY](#)

[VENEZUELA](#)

[YUGOSLAVIA](#)

**1576482**



[Website Hit Counter](#)

© Ivan Gogin, 2010-15

[home](#)[World navies yesterday](#)[1925](#)

# Argentina 01 January 1925

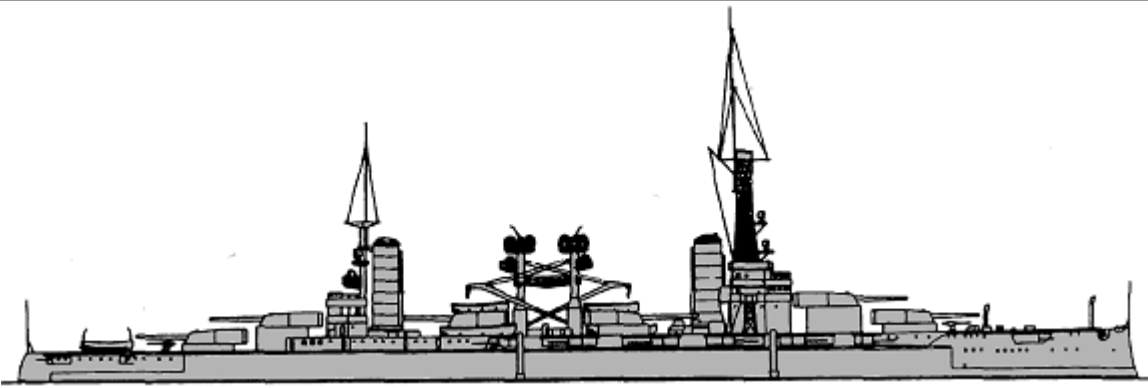
## BATTLESHIPS

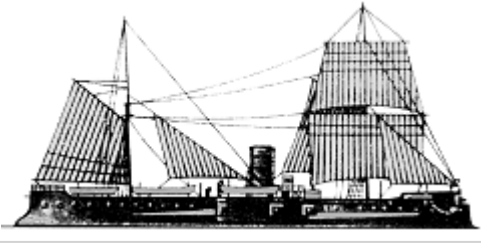
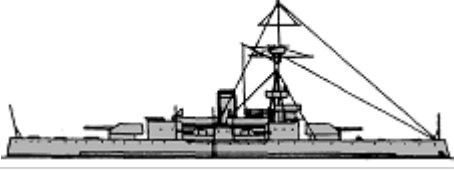

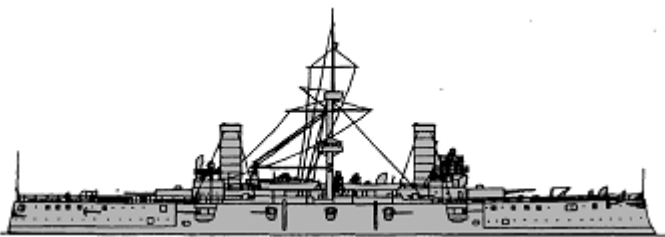
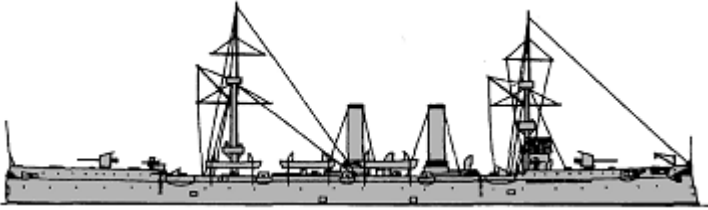

BB	Rivadavia	1	Rivadavia	1914		30600t, 181.3x30.0x8.5m, 18b,3gt, 39500hp, 22.5kts, 1130p;280belt (76+38)deck, 305turrets, 305CT; 6x2-305/50, 12x1-152/50, 16x1-102/50, 2-533TT
		2	Moreno	1915		
El Plata	El Plata	1	El Plata	1875		1500t, 56.7wlx13.4x3.2m, 4b,2vc, 750hp, 9.5kts, 126p; iron: 152belt, 30deck, 229turrets; 1x2-203/23, 2x1-120/40, 2x1-57/40, 4x1-25/40
		2	Los Andes	1875		
BC	Almirante Brown	1	Almirante Brown	1882		4200t, 73.2ppx15.2x6.2m, 8b,2vc, 5400hp, 14kts, 520p; compound: 229belt, 203battery, 203CT; 10x1-150/50, 6x1-120/50, 2x1-47/40, 2-450TT
		3				
Nueve de Julio	Nueve de Julio	4	Libertad	1892		2595t, 70.1ppx13.1x4.0m, 4b,2vte, 2780hp, 14.2kts, 230p; steel: 203belt, 37deck, 127turrets, 102CT; 2x1-240/35, 4x1-120/40, 4x1-47/40, 2-450TT
		5	Independencia			

## CRUISERS

		1	Garibaldi	1896
--	--	---	-----------	------

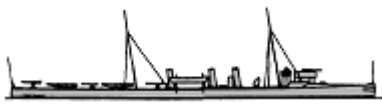
CA	Garibaldi	4	2	San Martin	1898		6775t, 111.7x18.2x7.1m, 8b(1-3)-16b(4),2vte, 13000hp, 20kts, 500-540hp; Harvey(1-3): 150belt, 37deck, 150turrets, 150CT; 2x1-254/40(1,3,4), 2x2-203/45(2), 10x1-152/40(1,2), 14x1-152/40(3,4), 6x1-120/40(1,2), 2x1-76/40(1,2,4), 4x1-76/40(3), 2x1-57/40(1), 4x1-57/40(2-4)
			3	General Belgrano	1898		
			4	Pueyrredon	1898		
CL	Nueva de Julio	1	1	Nueva de Julio	1893		3600t, 113.5x13.4x5.0m, 8b,2vte, 14500hp, 22.2kts, 327p; steel: 114slopes, 89deck, 51shields, 102CT; 4x1-152/40, 8x1-120/40, 12x1-47/40, 5-450TT
			1	Buenos Aires	1896		

### TORPEDO SHIPS

DD	Corrientes	3	1	Corrientes	1898		280t, 57.9x5.9x2.2m, 6b,2vte, 4200hp, 27kts, 54p; steel: 20belt; 1x1-75/55, 3x1-57/40, (1+2x1)-450TT			
			2	Entre Rios	1896					
			3	Misiones	1897					
DD	Catamarca	2	4	Catamarca	1912		1357t, 88.1x8.3x2.6m, 2b,2t, 25675hp, 27kts, 150p; 4x1-102/50, 4x1-533TT			
			5	Jujuy	1912					
DD	La Plata	2	6	Córdoba	1912		1368t, 90.0x9.0x2.8m, 5b,2t, 28000hp, 35kts, 150p; 4x1-102/50, 4x1-533TT			
			7	La Plata	1912					
TB	Bouchard	4	1-4	Bouchard, Bathurst, Jorge, Thorne	1890-1892		90t, 39.6ppx4.3x1.8m, 2b,1vte(1,3,4)-1vqe(2), 1110(1,3,4)-1230(2)hp, 23.5(1,3,4)-24.4(2)kts, 15p; 2x1-47/43, 1x4-25/40, (1+1x2)-450TT			
			2	5	Comodoro Py			1892	No picture	110t, 45.7x4.4x1.1m, 2b,1vte, 1800hp, 25kts, 27p; 2x1-47/43, 1x4-25/40, (1+1x2+1x1)-450TT
				6	Comodoro Murature			1892		

### OTHER FIGHTING SHIPS

PGR	Rosario	2	1	Rosario	1909		1055t, 76.4x9.8x2.1m, 2b,2vte, 1300hp, 14.5kts, 145p; 76belt, 25deck, 76CT; 2x1-152/13, 6x1-76/40



[home](#)

[World navies yesterday](#)



[1925](#)

# AUSTRALIA 01 January 1925

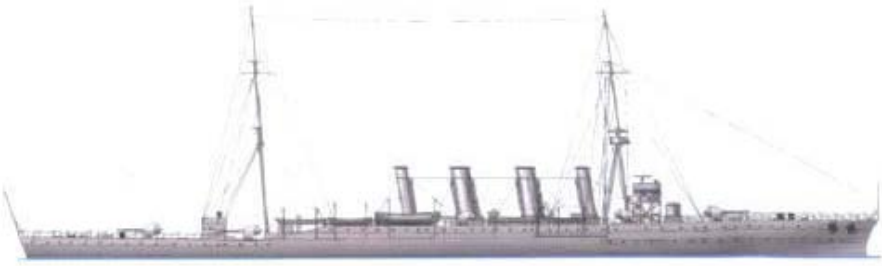
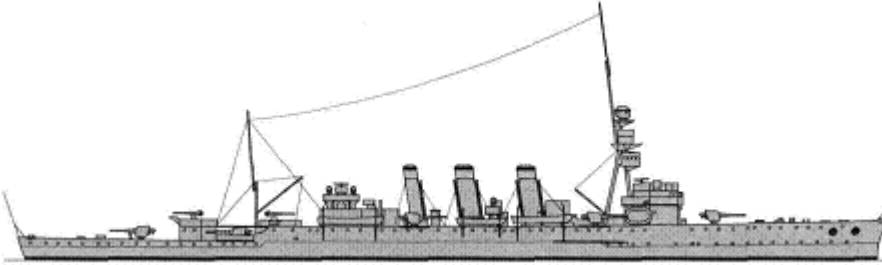
## CRUISERS

CL	Chatham	3	1	Melbourne	1913		6000t, 139.6x14.9x4.9m, 12b,4t, 25000hp, 25.5kts, 475p; 51belt, 38deck, 102shields, 102CT(3); 8x1-152/45, 1x1-76/45, 4x1-47/40, 2-533TT
			2	Sydney	1913		
			3	Brisbane	1916		
	Birmingham	1	4	Adelaide	1922		6160t, 141.0x15.2x4.9m, 12b,2gt, 25500hp, 25.5kts, 480p; 51belt, 38deck, 102shields, 102CT; 9x1-152/45, 1x1-76/50, 1x1-76/45, 4x1-47/40, 2-533TT

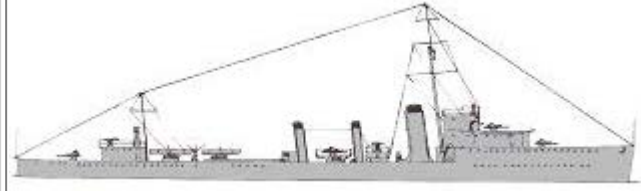
## TORPEDO SHIPS



DL	Parker	1	1	Anzac	1917		1912t, 99.0x9.7x3.7m, 4b,3t, 36000hp, 34kts, 116p; 4x1-102/40, 2x1-40/39, 2x2-533TT
	I-Australian	6	1	Parramatta	1910		990t, 75.0x7.8x2.7m, 3b,3t, 13500hp, 27kts, 70p; 1x1-102/40, 3x1-76/40, 3x1-450TT
			2	Yarra	1910		
			3	Warrego	1912		
			4	Huon	1915		
			5	Torrens	1916		

DD	S-Admiralty	5	6	Swan	1916		1225t, 84.1x8.1x2.7m, 3b,2gt, 27000hp, 36kts, 90p; 3x1-102/40, 1x1-40/39, 2x2-533TT, 2DCT, 1DCR
			7	Stalwart	1918		
			8	Success	1919		
			9	Swordsman	1919		
			10	Tasmania	1919		
			11	Tattoo	1919		

## SUBMARINES

SS	J	2	1	J4	1916		1204(1)-1212(2)/1820t, 84.0(1)-83.7(2)x7.0x4.3m, 3d/em, 3600/1350hp, 19.5/9.5kts, 44p, 50m; 1x1-102/40, 1x1-40/39, 6-450TT
			2	J7	1917		

## ESCORTS

SL	Acacia	1	1	Mallow	1915		1275t, 80.0x10.1x3.4m, 2b,1vte, 1800hp, 16.5kts, 90p; 2x1-102/40, 2x1-40/39, 2DCT, 1DCR, MS
	Arabis	2	2	Geranium	1916		1350t, 81.7x10.2x3.4m, 2b,1vte, 2000hp, 16kts, 104p; 2x1-102/40, 2x1-47/50, 2DCT, 1DCR, MS
			3	Marguerite	1916		
24		1	4	Silvio	1918		1493t, 81.5x10.7x3.2m, 2b,1vte, 2500hp, 17kts, 82p; 2x1-102/40, 2DCT, 2DCR, MS

© Ivan Gogin, 2010-15



[home](#)[World navies yesterday](#)[1925](#)

## Austria 01 January 1925

### RIVER BOATS

PGR	Fogas	1	1	Fogas	1916		60t, 36.0x4.6x0.9m, 2b,2vte, 800hp, 12kts, 27p; 5belt, 4deck, 5turret, 5CT; 1x1-66/30
	Barsch	2	2	Barsch	1916		133t, 44.0x6.0x1.0m, 2b,2gt, 1200hp, 15kts, 40p; 8belt, 6deck, 10turrets, 10CT; 2x1-77/30(2), 2x2-66/30(3)
			3	Compo	1916		
Stör	1	4	Stör	1918		160t, 45.5x6.0x1.0m, 2b,2gt, 1400hp, 16kts, 42p; 10belt, 6deck, 22turrets, 10CT; 2x1-77/30	

© Ivan Gogin, 2011-15

[home](#)[World navies yesterday](#)[1925](#)

## Belgium 01 January 1925

### TORPEDO SHIPS

TB	A1 PC	9	1	A1 PC	1915		137t, 41.6x4.6x1.2m, 1b,1vte, 1093hp, 19kts, 28p; 1x1-50/40, 2x1-450TT, 4m, MS
			2	A2 PC	1915		
			3	A3 PC	1915		
			4	A4 PC	1915		
			5	A5 PC	1915		
			6	A6 PC	1915		
			7	A7 PC	1915		
			8	A8 PC	1915		
			9	A9 PC	1915		
	A22 PC	5	10	A22 PC	1916		250t, 50.0x5.3x2.1m, 1b,1gt, 3250hp, 25kts, 29p; 2x1-88/30, 1x1-450TT, MS
			11	A23 PC	1917		
			12	A24 PC	1917		
			13	A25 PC	1917		
			14	A29 PC	1916		

### ESCORTS

SL	Zinnia	1	1	Zinnia	1915		1275t, 80.0x10.1x3.4m, 2b,1vte, 1800hp, 16.5kts, 90p; 2x1-120/40, 2x1-47/50, 2DCT, 1DCR, MS
----	--------	---	---	--------	------	--	---

### MINE WARFARE SHIPS

MSB	V1 Roi Albert	12	1 - 12	V1 Roi Albert, V2 Reine Elisabeth, V3 Prince Leopold, V4, V5 Chevalier Casaert, V6 Roi Leopold I, V7 Roi Leopold II, V8 Princesse Marie-José, V9 Dinant, V10 - 12	1917 - 1918		21t, 17.5x4.0x1.1m, 2pe, 120hp, 10kts, 7p; 1x5-37/23, MS
-----	---------------	----	--------	---	-------------	--	--



[home](#)[World navies yesterday](#)[1925](#)

## Brazil 01 January 1925

### BATTLESHIPS

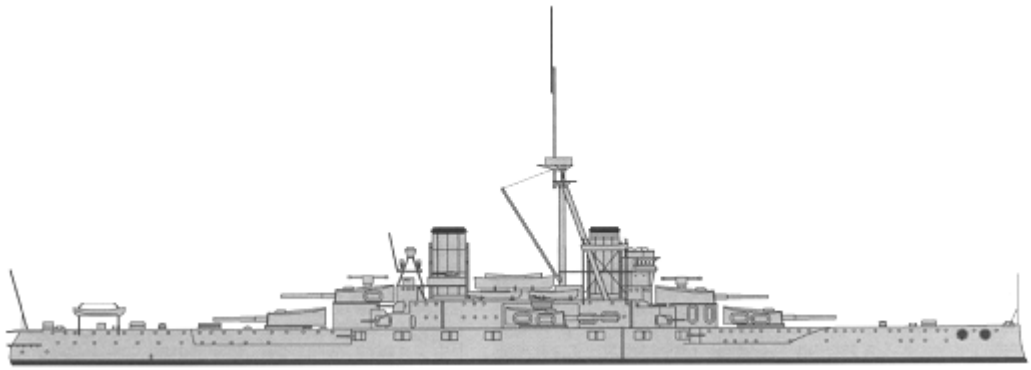
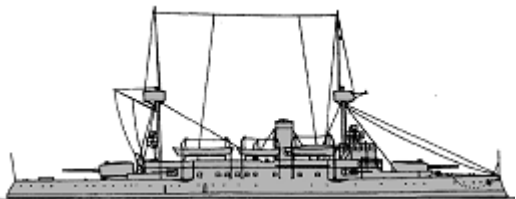

BB	Minas Gerais	1	Minas Gerais	1910		<p>21200t, 165.5x25.33x7.6m, 18b,2vte, 23500hp, 21kts, 900p; 229belt, 51deck, 229turrets, 305CT; 6x2-305/45, 12x1-120/50, 2x1-76/50, 8x1-37/32</p>
		2	São Paulo	1910		
BC	Marshal Deodoro	1	Marshal Floriano	1901		<p>3162t, 81.5x14.4x4.2m, 8b,2vte, 3400hp, 15kts, 200p; Harvey: 350belt, 45deck, 220turrets, 125CT; 2x1-234/45, 4x1-120/50, 6x1-57/40, 2-450TT</p>

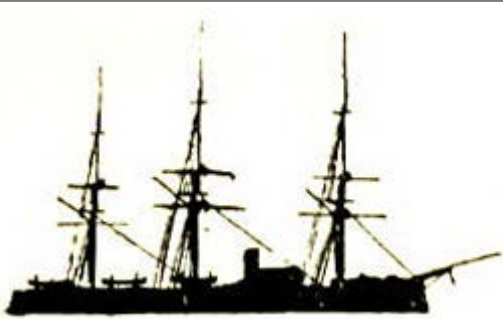
### CRUISERS

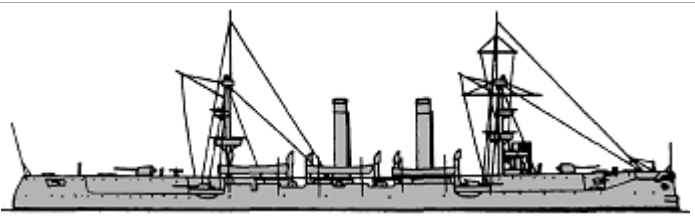
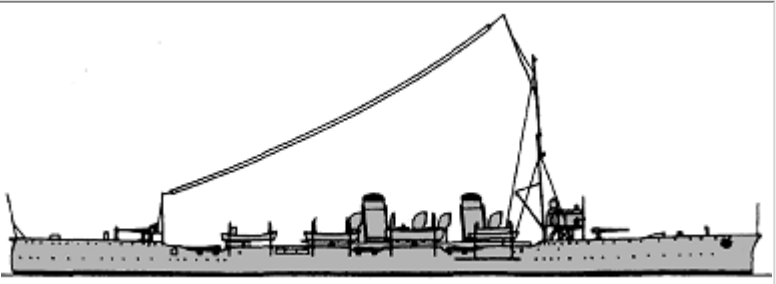
	Benjamin Constant	1	Benjamin Constant	1892		<p>2820t, 72.1x13.6x5.6m, 2vte, 4000hp, 15kts, 216p; steel: 51deck, 95CT; 4x1-152/40, 8x1-120/40, 2x1-76/40, 2x1-37/23, 2x5-37/20, 4-450TT</p>

CL	Almirante Barroso	1	2	Almirante Barroso	1897		3437t, 108.0x13.3x5.2m, 4b,2vte, 7500hp, 20.2kts, 366p; Harvey: 88slopes, 31deck, 102CT; 6x1-152/50, 4x1-120/50, 10x1-57/40, 4x1-37/23, 3-450TT
	Bahia	2	4	Rio Grande do Sul	1910		3185t, 122.4x11.9x4.4m, 10b,3t, 18000hp, 26.5kts, 350p; 31slopes, 19deck, 76CT; 10x1-120/50, 6x1-47/40, 2x1-450TT

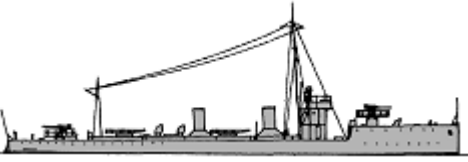
### TORPEDO SHIPS

PGT	Tiradentes	1	1	Tiradentes	1893		795t, 50.3ppx9.1x3.3m, 2vte, 1646hp, 14.5kts, 110p; steel: 25CT; 4x1-120/40, 3x1-57/40, 2x1-356TT
DD	Pará	10	1	Amazonas	1909		560t, 73.2ppx7.2x2.4m, 2b,2vte, 8000hp, 27kts, 130p; 2x1-102/40, 4x1-47/40, 2x1-450TT
			2	Pará	1909		
			3	Piaui	1909		
			4	Rio Grande do Norte	1909		
			5	Paraíba	1909		
			6	Alagoas	1910		
			7	Sergipe	1910		
			8	Paraná	1910		
			9	Santa Catharina	1910		
			10	Mato Grosso	1909		
	Alexandrino Dealenca	1	11	Maranhão	1914		1300t, 81.5x8.2x2.9m, 4b,2t, 24500hp, 29kts, 73p; 3x1-102/40, 2x1-47/50, 2x2-450TT
TB	Goíás	1	1	Goíás	1907	No picture	150t, 46.3ppx4.7x1.3m, 2vte,1t(3), 950hp, 26kts, 30p; 2x1-47/40, 2x1-450TT

### SUBMARINES

SS	F1	3	1	F1	1913		250/305t, 46.0ppx4.4x3.7m, 2d/em, 700/500hp, 13.5/8kts, 20p, 40m; 2-450TT
			2	F2	1914		
			3	F3	1914		

## OTHER FIGHTING SHIPS



RMON	Pernambuco	1	1	Pernambuco	1910		470t, 44.5x7.3x1.6m, 2b,2vte, 800hp, 11kts, 60p; 168belt, 102deck, 152turret, 89CT; 1x2-120/45, 2x1-57/43, 2x1-37/32
PGR	Yutohy	1	1	Teffé	1892	No picture	33t, 27.4ppx4.6x1.5m, 11kts; 1x1-47/40
	Acre	1	2	Missões	1906	No picture	200t, 36.6x6.1x0.6m, 1b,1vte, 300hp, 11kts; 1x1-87/13, 1x1-57/43
APGR	-	4	1	Oyapock	1908		295t
			2	Teniente Mário Alves	1913		280t
			3	Amapá	1912		320t
			4	Ajuricaba	1923		120t

© Ivan Gogin, 2011-15



[home](#)[World navies yesterday](#)[1925](#)

## Bulgaria 01 January 1925

### TORPEDO SHIPS

TB	Druzki	4	1	Druzki	1908		98t, 38.0x4.4x1.3m, 2b,1vte, 1950hp, 26kts, 32p; 2x1-47/50, MS
			2	Smeli	1908		
			3	Khrabri	1908		
			4	Strogi	1909		
	Vasil Levski	2	5, 6	Vasil Levski, Khristo Botev	1877-1878		20t, 18.3x2.3x1.1m, 1b,1vc, 220hp, 13kts, 9p

### COASTAL FORCES

PS	Belomorets	2	1, 2	Belomorets, Chernomorets	1917		87t, 33.5x4.5x1.7m, 3pe, 660hp, 18kts, 27p; 1x1-47/50
YP	Minyor	4	1-4	Minyor, Vzriv, Konduktor Dokuzanov, Kapitan-Leytenant K. Minkov	1918		41t, 23.4x3.7x1.5m, 2pe, 440hp, 14kts, 16p; 1x1-75/35, 1DCT

© Ivan Gogin, 2011-15

[home](#)

[World navies yesterday](#)

[1925](#)

# CANADA 01 January 1925

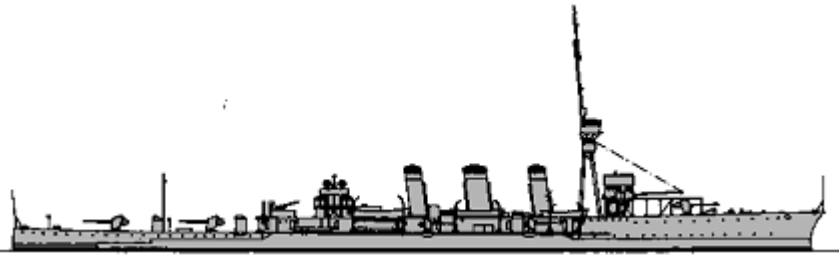

## CRUISERS

CL	Arethusa	1	1	Aurora	1914		4400t, 132.9x11.9x4.1m, 8b,4t, 40000hp, 28.5kts, 276p; 76belt, 25deck, 102shields, 76CT; 2x1-152/45, 6x1-102/40, 2x1-76/45, 4x2-533TT, 70m
----	----------	---	---	--------	------	--	--

## TORPEDO SHIPS

DD	M-Thornycroft	2	1	Patrician	1916		1130t, 83.7x8.4x2.6m, 3b,3t, 26500hp, 35kts, 80p; 3x1-102/40, 1x1-40/39, 2x2-533TT
			2	Patriot	1916		

## SUBMARINES

SS	CC	2	1	CC1	1914		313/373t, 44.0(1)-48.0(2)x4.6(1)-4.3(2)x3.4m, 1pe/em, 600/240(1)-260(2)hp, 13/10.2kts, 18p, 30m; 5-450TT(1), 3-450TT(2)
			2	CC2	1914		
	H-I	2	3	CH14	1915		364/434t, 45.8x4.7x3.8m, 2d/em, 480/620hp, 13/11kts, 22p, 30m; 4-450TT
			4	CH15	1915		

## MINE WARFARE

TL	Ypres	6	1	Festubert	1917	No picture	440t, 39.6x7.1x4.1m, 1vte, 10.5kts; 1x1-76/40, MS
			2	Ypres	1917		
			3	Armentieres	1918		
			4	Arras	1918		



			5	Givenchy	1918		
			6	Thiepval	1918		
DF	Admiralty wooden	4	1	Ebbtide	1917		175t, 28.7x6.1x2.2m, 1b,1vte, 270hp, 9kts; 1x1-57/40, MS
			2	CD17	1917		
			3	Eventide	1917		
			4	Floodtide	1917		

© Ivan Gogin, 2010-15

[home](#)[World navies yesterday](#)[1925](#)

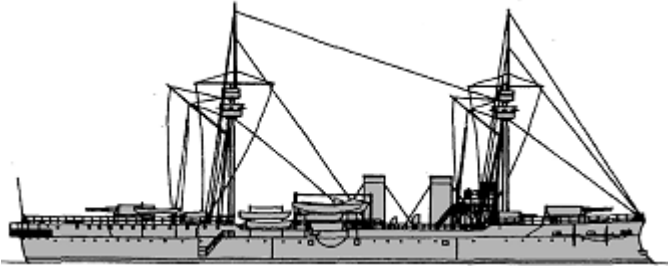
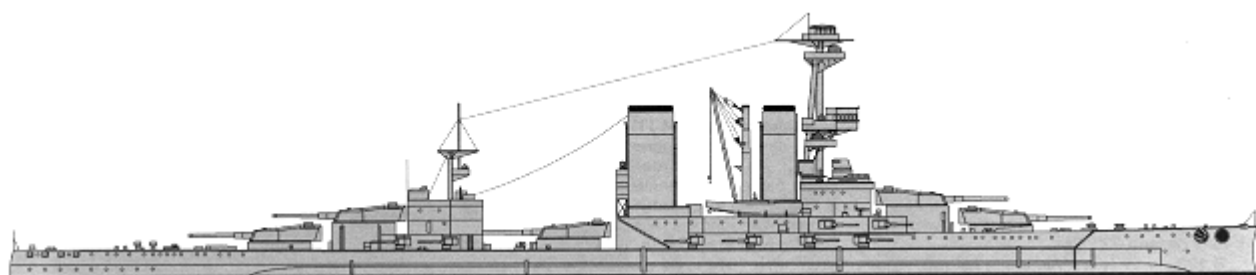

## Chile 01 January 1925

### CAPITAL SHIPS

BB	Capitán Prat	1	1	Capitán Prat	1893		6901t, 100.0ppx18.5x7.0m, 12b,2hte, 12000hp, 19kts, 480p; Creusot steel; 300belt, 50deck, 275barbettes, 265CT; 4x1-240/36, 4x2-120/45, 10x1-57/40, 2-450TT
	Almirante Latorre	1	2	Almirante Latorre	1915		32300t, 201.5x28.0x8.7m, 21b,4t, 37000hp, 22.7kts, 1167p; 229belt, (25+37)deck, 254turrets, 279CT; 5x2-356/45, 14x1-152/50, 2x1-76/45, 4-533TT

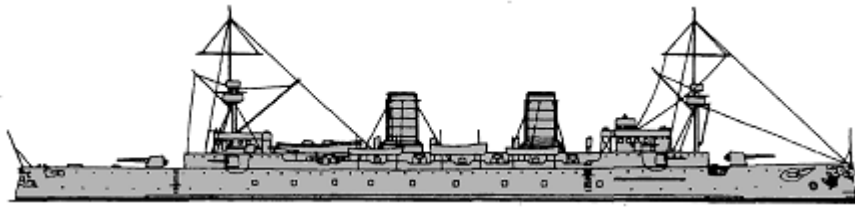
### CRUISERS

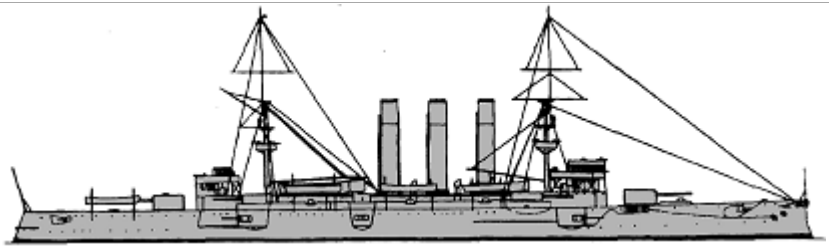
CA	Esmeralda	1	1	Esmeralda	1896		7000t, 132.9ppx16.2x6.2m, 12b,2vte, 16000hp, 22.2kts, 500p; Harvey; 152belt, 51deck, 114shields, 203CT; 2x1-203/40, 12x1-152/40, 8x1-76/40, 3-450TT
	O'Higgins	1	2	O'Higgins	1898		8500t, 135.2x19.1x6.7m, 30b,2vte, 16000hp, 21kts, 500p; Harvey; 178belt, 51deck, 178turrets, 229CT; 4x1-203/40, 10x1-152/40, 13x1-76/40, 3-450TT

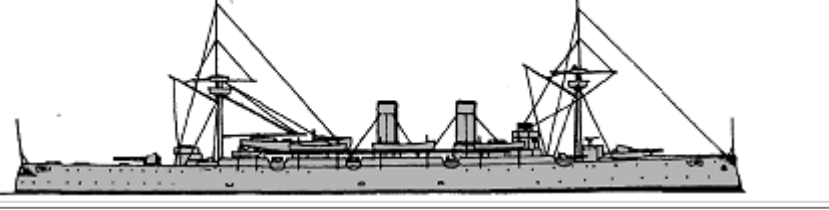
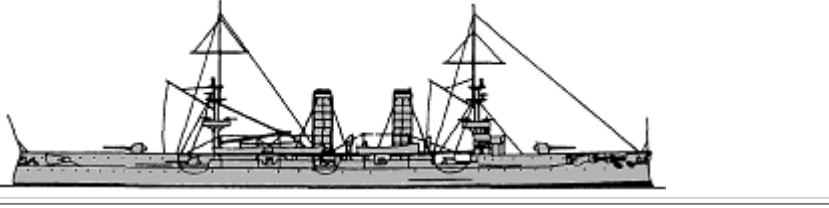
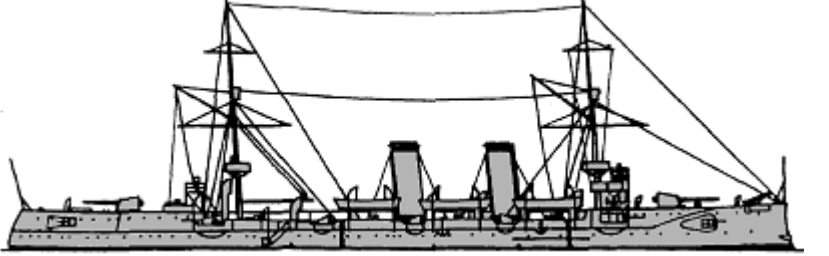
						
	Presidente Errázuriz	1 1	Presidente Errázuriz	1892		2047t, 81.8ppx10.9x4.4m, 4b,2hte, 5400hp, 18.3kts, 170p; Steel; 60slopes, 35deck, 90shields, 50CT; 4x1-150/45, 2x1-120/45, 4x1-57/40, 3-356TT
	Blanco Encalada	1 2	Blanco Encalada	1894		4568t, 112.8ppx14.2x5.6m, 8b,2vte, 14600hp, 22.8kts, 427p; Steel; 102slopes, 44deck, 152shields, 152CT; 2x1-203/40, 10x1-152/40, 5x1-76/40, 1x1-40/39
CL	Ministro Zenteno	1 3	Ministro Zenteno	1898		3437t, 100.6ppx13.3x5.1m, 8b,2vte, 7500hp, 20.2kts, 317p; Steel; 89slopes, 32deck, 102CT; 8x1-152/40, 10x1-57/40, 4x1-37/23, 3-450TT
	Chacabuco	1 4	Chacabuco	1902		4877t, 127.5x14.2x5.2m, 8b,2vte, 15700hp, 23kts, 400p; Harvey; 114slopes, 44deck, 114shields, 76CT; 2x1-203/45, 10x1-120/40, 12x1-76/40, 6x1-47/40, 3-450TT

TORPEDO SHIPS

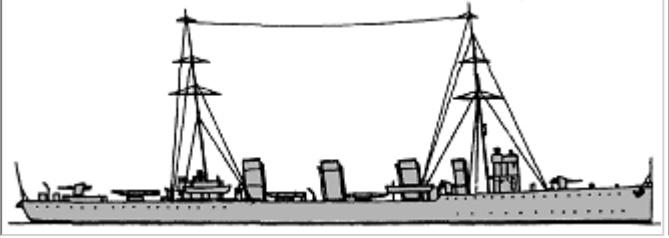
		1	Almirante Lynch	1913		1850t, 100.8x9.9x3.4m, 6b,3t, 30000hp, 31kts, 160p; 6x1-102/40, 4x1-450TT
	Almirante Lynch	2	Almirante Condell	1914		
DD	Almirante Williams	3	Almirante Williams	1915		1829t, 101.0x9.9x3.5m, 6b,3t, 30000hp, 31kts, 205p; 2x1-120/45, 2x1-102/45, 2x1-40/39, 2x2-533TT(3), 4x1-533TT(4,5)
		3	Almirante Uribe	1914		
			Almirante			

			5	Riveros	1914		

## SUBMARINES

SS	H1	6	1	H1	1915		364/434t, 45.8x4.7x3.8m, 2d/em, 480/620hp, 13/11kts, 22p, 30m; 4-450TT
			2	H2	1915		
			3	H3	1915		
			4	H4	1916		
			5	H5	1916		
			6	H6	1916		

## ESCORTS

PC	Yelcho	1	1	Yelcho	1908	No picture	467t, 39.0x7.0x2.9m, 1vte, 350hp, 12kts; 1x1-37/23
	Piloto Sibbald	1	2	Piloto Sibbald	1916	No picture	1100t, 43.1x8.7x3.4m, 2b,2vte, 1200hp, 11.5kts, 18p; 1x1-37/23

## MINE WARFARE SHIPS

ML	Elicura	4	1	Elicura	1920		545t, 52.6x7.5x3.4m, 3b,2vte, 1400hp, 14.5kts, 42p; 2x1-76/40, 50m
			2	Leucoton	1920		
			3	Orompello	1920		
			4	Colocolo	1920		

[home](#)[World navies yesterday](#)[1925](#)



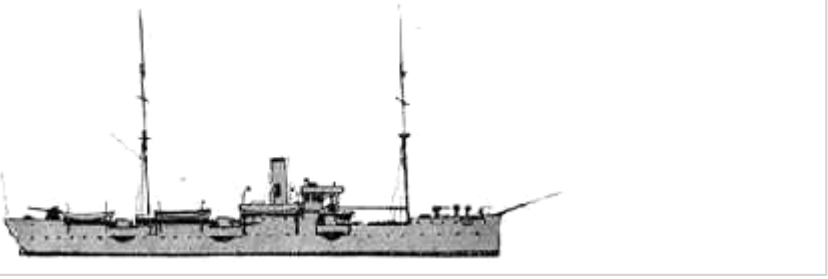
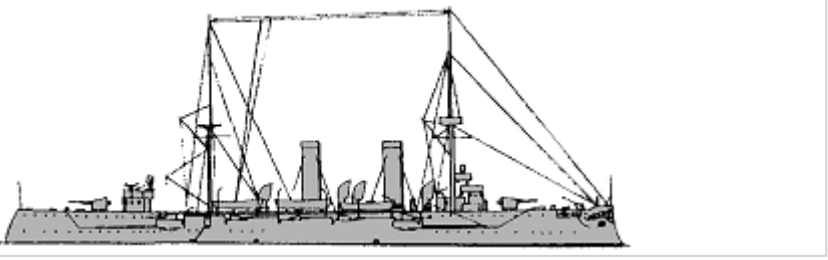
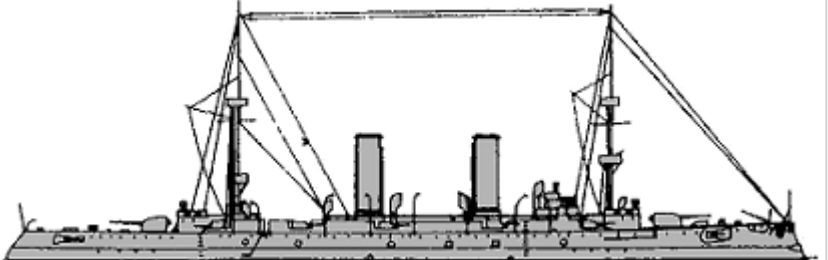
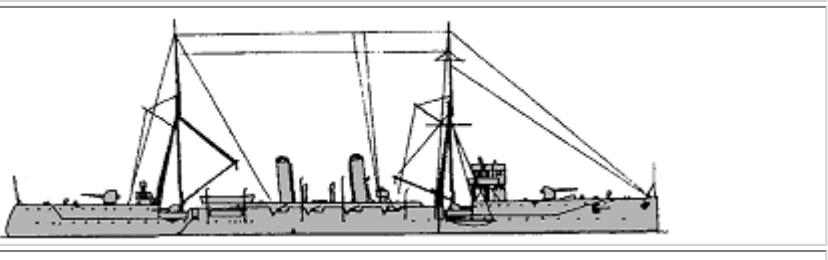

# China 01 January 1925

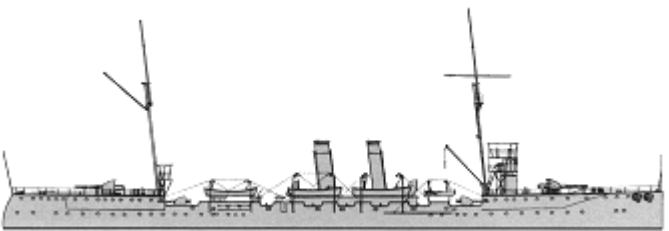
## CRUISERS

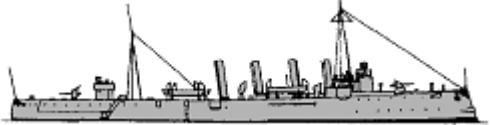
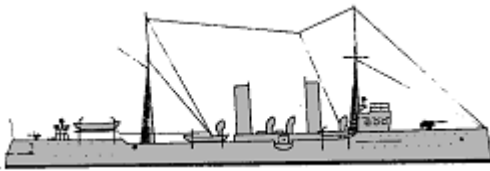

						1900t, 77.0ppx10.4x4.9m, 4b,1vc, 1600hp, 11.6kts, 335p; 2x1-152/50, 5x1-120/45, 3x1-57/40, 8x1-37/23
						2950t, 100.0x12.4x5.8m, 8b,2vte, 7500hp, 19.5kts, 244p; 32deck, 70slopes, 51shields, 37CT; 3x1-150/40, 8x1-105/40, 6x1-47/40, 3-356TT
CL						4515t, 129.2x14.2x5.5m, 12b,4vte(2), 17000hp, 24kts, 350p; 37deck, 127slopes, 114gunhouses, 152CT; 2x1-203/45, 10x1-120/45, 12x1-47/40, 4x1-37/32, 5-450TT
						2500t, 105.0x11.9x4.0m, 6b,3t, 6000hp, 20kts, 270p; 25deck, 37slopes, 76CT; 2x1-152/50, 4x1-102/50, 4x1-76/50, 6x1-47/40, 2x1-37/32, 2x1-450TT



	Chao Ho	1	7	Chao Ho	1912		2750t, 105.5x12.8x4.5m, 8b,3t, 6000hp, 20kts, 283p; 25deck, 51slopes, 76CT; 2x1-152/50, 4x1-102/50, 4x1-76/50, 6x1-47/40, 2x1-37/32, 2x1-450TT
--	---------	---	---	---------	------	---	--

## TORPEDO SHIPS



PGT	Fei Ying	1	1	Fei Ying	1896		850t, 75.0x8.6x4.0m, 8b,2vte, 5430hp, 22kts, 90p; 25deck, 50shields; 2x1-105/40, 6x1-57/40, 4x1-37/23, (1+2x1)-356TT
	Chien Wei	2	2	Chien Wei	1903		900t, 79.2x8.1x3.5m, 4b,2vte, 6500hp, 20.5kts, 140p; 25belt, 25deck; 1x1-100/45, 3x1-65/60, 6x1-37/32, 2x1-356TT
		3	3	Chien An	1903		
DD	Fu Po	1	1	Yu Chang	1911		390t, 60.4x6.5x1.8m, 4b,2vte, 6500hp, 32kts, 69p; 2x1-76/50, 2x1-47/40, 2x1-450TT
		2	2	Chien Kang	1912		
		3	3	Tung An	1912		
TB	Lei Fu	2	1, 2	Lei Fu, Lei Lung	1884	No picture	64t, 35.0x4.0x1.7m, 2b,1vte, 700hp, 19.8kts, 20p; 2x5-37/20, 2-356TT
	Lei Chen	9	3 - 11	Lei Chen, Lei Chung, Lei Kong, Lei Kwong, Lei Kung, Lei Li, Lei Sun, Lei Tsen, Lei Tui	1885	No picture	27t, 26.0x3.6xm, 1b,1vc, 420hp, 19.5kts; 1-356TT
	Chang Tze	2	12, 13	No1 Chang Tze, No3 Lieh Tze	1895	No picture	89t, 39.0x4.8x1.5m, 1b,1vc, 600hp, 18kts, 31p; 2x5-37/20, (2+1x1)-356TT
	Chen Tse	2	14	No2 Chen Tse	1896		126t, 43.9x5.2x2.4m, 2b,1vte, 1000hp, 18kts, 31p; 2x5-37/20, (2+1x1)-450TT
			15	No4 Su Tse	1896		
	Hu Peng	4	16	No7 Hu Peng	1906		120t, 41.1x4.9x2.1m, 2b,1vte, 1200hp, 23kts, 34p; 2x1-47/40, (1+2x1)-450TT
			17	No8 Hu Oah	1906		
18			No9 Hu Ying	1907			
19			No10 Hu Chen	1907			



## ESCORTS

PC	Yi Sheng	1	1	Yi Sheng	1911		350t, 36.7x6.3x3.4m, 1b,1vte, 500hp, 10kts, 37p; 1x1-65/60, 1x1-57/40
	Hai Yen	1	2	Hai Yen	1917	No picture	60t, 19.8x3.7x0.7m, 1b,2vte, 60hp, 10kts; 1x1-37/32
	Hai Ku	2	3	Hai Ku	1917		200t, 34.1x5.5x2.6m, 1b,2vte, 300hp, 10.5kts, 22p; 2x1-37/32
			4	Hai Hung	1917		
			5	Hai Fu	1917		

Hai Fu	2	6	Hai Ou	1917		166t, 33.2x5.2x2.4m, 1b,1vte, 220hp, 10.5kts, 22p; 1x1-37/32
		7	Hai Hao	1917		
Hai Hao	2	8	Hai Peng	1920		230t, 32.3x5.5x2.0m, 1b,1vte, 200hp, 12kts, 22p; 4x1-37/32

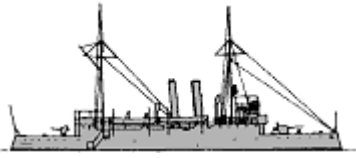
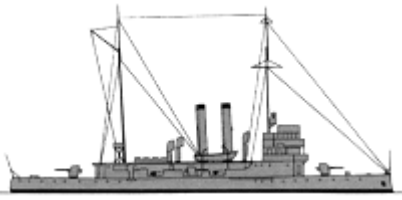
## OTHER FIGHTING SHIPS

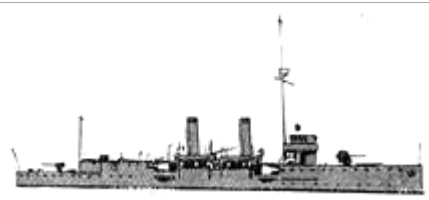
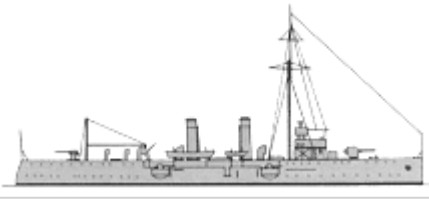
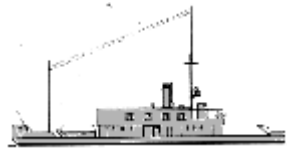
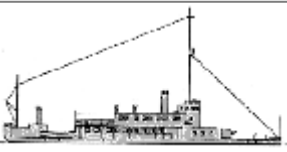
Kwang Tung	2	1	An Lan	1868	No picture	440t, 42.7x7.2x2.7m, 3b,1hr, 255hp, 9.3kts, 60p; 1x1-178/12, 2x1-120/22
		2	Chen T'ao	1868		
Fei Ting	2	3	Fei Ting	1876		420t, 36.6x9.1x2.4m, 1b,2hcr, 270kts, 9.5kts, 30p; 13shield, 13CT; 1x1-318/16, 2x1-70/25, 1x4-25/40
		4	Tse Tien	1876		
Hai Ch`ang Ch`ing	1	5	Hai Ch`ang Ch`ing	1877		430t, 38.1x9.1x2.4m, 1b,2hrc, 70kts, 7.5kts; 1x1-254/14, 2x1-70/25
Kuang Yuan	4	6	Kuang Yuan	1886	No picture	300t, 33.8x5.5x2.3m, 2hr, 78hp, 10kts; 1x1-150/35, 1x1-88/35, 3x1-37/40
		7	Kuang Heng	1886		
		8	Kuang Li	1886		
		9	Kuang Chien	1886		
Kuang Keng	4	10	Kuang Keng	1887	No picture	560t, 43.0x7.3x3.7m, 1vr, 400hp, 11kts; 2x1-120/22, 1x1-100/22, 2x1-47/40
		11	Kuang Hsing	1887		
		12	Kuang Jen	1887		
		13	Kuang Kuei	1887		
Kiang Yuan	4	14	Kiang Yuan	1905		565t, 54.1x8.5x2.1m, 2b,2vte, 950hp, 13kts, 85p; 1x1-120/40, 1x1-76/40, 4x1-47/40
		15	Kiang Heng	1907		
		16	Kiang Li	1907		
		17	Kiang Chen	1907		
Chu Tung	6	18	Chu Tung	1906		752t, 61.0x9.0x2.4m, 2b,2vte, 1350hp, 13kts, 117p; 2x1-120/40, 2x1-76/40
		19	Chu Chien	1906		
		20	Chu Tai	1906		
		21	Chu Yu	1907		
		22	Chu Yiu	1907		
		23	Chu Kuan	1907		
Kuan Chuan	1	24	Kuan Chuan	1908	No picture	305t, 36.3x6.1x2.3m, 1b,1vc, 300hp, 7.9kts, 26p; 2x1-37/32
An Feng	1	25	An Feng	1908	No picture	169t, 37.2x5.6x1.7m, 1b,1vc, 350hp, 12.1kts
Lien Ching	1	26	Lien Ching	1911	No picture	500t, 53.3x7.6x2.9m, 2b,2vte, 925hp, 13.5kts, 60p; 4x1-47/40
Wu Feng	1	27	Wu feng	1912	No picture	200t, 37.8x6.1x2.1m, 1b,1vte, 300hp, 10kts, 46p; 2x1-65/60
		28	Yung Feng	1913		

	Yung Feng	2	29	Yung Hsiang	1913		1020t, 65.8x9.0x2.4m, 2b,2vte, 1350hp, 13kts, 108p; 25deck; 1x1-105/40, 1x1-76/50, 4x1-47/40, 2x1-37/32
	Yung Chien	2	30	Yung Chien	1915		1039t, 65.7x9.0x3.5m, 2b,2vte, 1350hp, 13kts, 105p; 25deck; 1x1-102/40, 1x1-76/40, 4x1-47/40, 2x1-37/32
			31	Yung Chi	1916		
PR	Chiang Kung	4	1	Chiang Kung	1909		200t, 44.0x6.0x1.6m, 1b,2vte, 500hp, 14kts, 62p; 1x1-76/40
			2	Chiang Chi	1909		
			3	Chiang Ku	1909		
			4	Chiang Tai	1909		
	Chiang Hsi	2	5	Chiang Hsi	1912		140t, 43.9(5)-44.5(6)x7.5(5)-7.3(6)x0.6m, 2b,2vte, 450(5)-500(6)hp, 12kts, 49p; 1x1-88/22
			6	Chiang Kun	1912		
	Chien Chung	3	7 - 9	Chien Chung, Yung An, Kung Chen	1915 - 1916	No picture	90t, 35.5x5.6x0.6m, 1b,2vte, 450hp, 11kts, 42p; 1x1-88/22
Li Sui	1	10	Li Sui	1904		280t, 50.1x8.0x0.9m, 2b,2vte, 1300hp, 13kts, 58p; 1x1-88/30, 1x1-50/40	
Li Chieh	1	11	Li Chieh	1910		314t, 54.1x8.7x0.8m, 2b,2vte, 1300hp, 13kts, 58p; 2x1-52/55	

## COASTAL FORCES

PT	Kuai 1	2	1, 2	Kuai 1, 2	1918		13t, 16.4x2.9x1.4m, 2pe, 500hp, 26kts, 8p; 2-450TT, 1DCR
----	--------	---	------	-----------	------	--	--



[home](#)[World navies yesterday](#)[1925](#)

## Colombia 01 January 1925

### CRUISERS

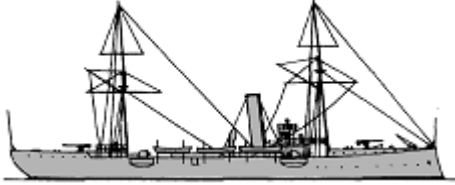
CL	Almirante Lezo	1	1	Almirante Lezo	1892		1200t, 70.0x10.0x2.6m, 1vte, 2500hp, 18kts, 150p; 2x1-120/40, 4x1-37/40, 4-356TT
----	----------------	---	---	----------------	------	--	--

### OTHER FIGHTING SHIPS

PGR	General Pinzon	1	1	General Pinzon	1881	No picture	740t, sw, 13kts; 3x1-37/23
	Esperanza	2	2	Esperanza	1897	No picture	400t, 42.4ppx5.8x0.9m, sw, 430hp, 15kts; 3x1-37/23
			3	General Nerino	1895		
	Chercinto	1	4	Chercinto	1896	No picture	643t, 56.4x9.4x3.7m, 400hp, 12kts; 3x1-37/23

### COASTAL FORCES

YPR	No1	4	1-4	No1-4	1913	No picture	20t, 24.0x3.8x1.2m, pe, 160hp, 12kts, 6p; 1x1-37/32
-----	-----	---	-----	-------	------	------------	---

© Ivan Gogin, 2011-15

[home](#)[World navies yesterday](#)[1925](#)

# Cuba 01 January 1925

## OTHER FIGHTING SHIPS

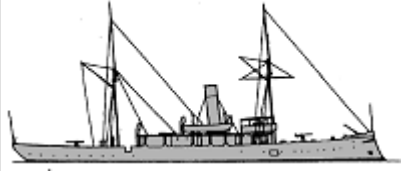
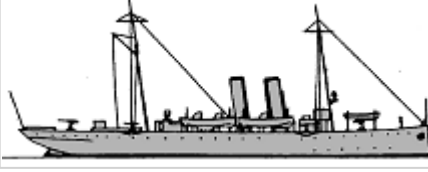
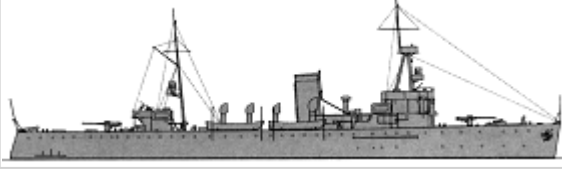
PG	Baire	1	1	Baire	1906		510t, 59.7x7.0x2.7m, 1vte, 1200hp, 14kts, 76p; 4x1-76/50, 2x1-37/40
	Santa Clara	1	2	Santa Clara	1911	No picture	52t, 32.0x1.8m, 12kts, 17p; 1x1-37/40
	Diez de Octubre	2	3	Diez de Octubre	1911	No picture	218t, 33.6x6.1x2.4m, 1vte, 12kts, 39p; 3x1-47/40
			4	Veinte y Cuatro de Febrero	1911		
	Patria	1	5	Patria	1911		1200t, 61.0ppx11.0x4.0m, 2vte, 4000hp, 16kts, 115p; 4x1-57/40, 4x1-47/40
	Cuba	1	6	Cuba	1911		2055t, 79.2x11.9x4.3m, 2vte, 6000hp, 18kts, 145p; 2x1-102/50, 4x1-57/40, 4x1-47/40, 4x1-37/40
	Habana	2	7,8	Habana, Pinar del Río	1912	No picture	80t, 30.5x5.5x1.3m, 1vte, 200hp, 12kts, 20p; 1x1-37/40
General Juan Bruno Zayas	1	9	General Juan Bruno Zayas	1914	No picture	300t, 50.0x3.4m, 11kts, 51p; 2x1-37/40	

## COASTAL FORCES

SC	CS1	4	1-4	CS1-4	1918		85t, 33.5x4.5x1.7m, 3pe, 660hp, 18kts, 27p; 1x1-76/23, 1DCT
----	-----	---	-----	-------	------	---	---

## COAST GUARD SHIPS

CGS	Veinte de Mayo	1	1	Veynte de Mayo	1895	No picture	203t, 45.7x5.6x3.2m, 500hp, 12kts, 43p; 2x1-47/40, 2x1-37/40
	Yara	1	2	Yara	1895	No picture	449t, 47.2x7.9x4.0m, 600hp, 12kts, 53p; 2x1-57/40, 2x1-47/40
	Alfredo	1	3	Alfredo	1896	No picture	40t, 18.3x3.7x1.8m, 11kts; 1x1-37/40
	Maceo	3	4-6	Maceo, Cespedes, Argamonte	1896	No picture	35t, 22.9x3.1x1.7m, 10kts; 1x1-37/40
	Enrique Villuendas	1	7	Enrique Villuendas	1899	No picture	178t, 40.2x6.1x2.7m, 600hp, 16kts; 2x1-47/40
	Matanzas	2	8,9	Matanzas, Las Villas	1912	No pictures	80t, 30.5x5.5x1.3m, 1vte, 200hp, 12kts, 20p; 1x1-37/40

© Ivan Gogin, 2012-15

[home](#)[World navies yesterday](#)[1925](#)

## Czechoslovakia 01 January 1925

### RIVER BOATS

PGR	Md-1	2	1, 2	OMd1, 2	1920		35t, 21.0x4.0x1.6m, 1d, 225hp, 10.8kts, 43p; 2x1-75/15, 10m
YPR	OMh3	3	1-3	OMh3-5	1924		24t, 16.9x2.8x0.8m, 1pe, 100hp, 10.8kts, 9p

### MINE WARFARE BOATS

MLBR	Ms-5	2	1, 2	OMm33, 34	1920		24t, 16.9x2.8x0.8m, 1d, 100hp, 10.8kts, 6p; 7m
------	------	---	------	-----------	------	---	--

© Ivan Gogin, 2011-15

[home](#)[World navies yesterday](#)[1925](#)

## Denmark 01 January 1925



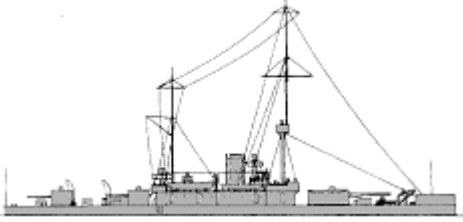
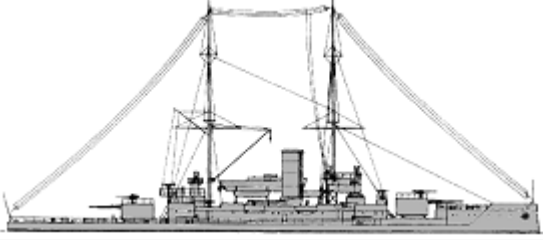
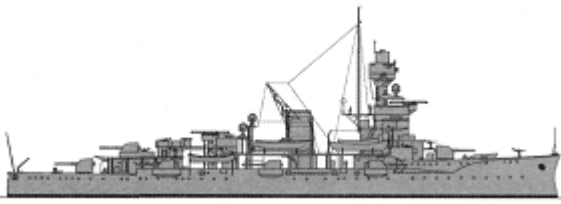

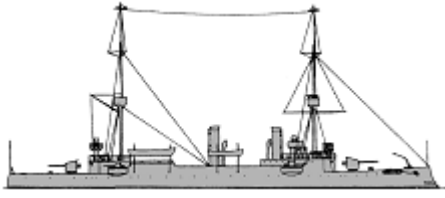

## CAPITAL SHIPS

	Skjold	1	1	Skjold	1897		2195t, 69.4x11.6x4.2m, 4b,2vte, 2400hp, 14kts, 138p; h: 229belt, 50deck, 250turret; 1x1-240/40, 3x1-120/40, 3x1-47/44
BC	Herluf Trolle	3	2	Herluf Trolle	1901		3650(2)-3700(3)-3785(4)t, 86.5(2,3)-87.4(4)x 15.1(2)-15.4(3)-15.7(4)x 4.9(2)-5.0(3,4)m, 6b,2vte, 4200(2,3)-5400(4)hp, 15.5(2,3)-16(4)kts, 258p; s(2)-k(3,4): 195belt, 65deck, 175(2)-190(3,4)turrets, 190CT; 2x1-240/40(2), 2x1-240/43(3,4), 4x1-150/43(2,3), 4x1-150/50(4), 6x1-75/55(2,3), 10x1-75/55(4), 2x1-57/44(2,3), 8x1-37/23(2), 2x1-37/23(3,4), 3-450TT(2,3), 4-450TT(4)
			3	Olfert Fischer	1905		
			4	Peder Skram	1908		
	Niels luel	1	5	Niels luel	1923		4100t, 90.0x16.3x5.0m, 4b,2vte, 5800hp, 16kts, 369p; 195belt, 55deck, 45shields, 170CT; 10x1-150/45, 4x1-57/55, 2-450TT

## CRUISERS



CL	Gejser	2	1	Gejser	1893		1282-1342t, 72.3x10.4x3.5(1)-3.6(2)m, 8b,2vte, 3000hp, 17kts, 156p; s: 50(1)-45(2)deck; 2x1-120/40, 4x1-87/40, 4x1-57/44, 1-450TT, 3-381TT
			2	Hejmdal	1895		
CLL	Ingolf	1	1	Ingolf	1878	No picture	1012t, 63.9x8.5x4.2m, 1vte, 630hp, 10.2kts, 156p; 2x1-120/40, 2x1-57/44, 3x1-37/23, 2x5-37/20

## TORPEDO SHIPS

TB	Hajen	1	1	Hajen	1896		141t, 42.9x4.6x2.5m, 2b,2vte, 2000hp, 22kts, 25p; 1x1-47/44, 1x5-37/23, 2-450TT, 1x2-381TT
	Havørnen	2	2	Havørnen	1897		142t, 44.4x4.7x2.4m, 2b,2vte, 2100hp, 22kts, 25p; 1x1-47/44, 1x5-37/20, (2+1x2)-450TT
			3	Søbjørnen	1898		
	Ormen	1	4	Ormen	1907		105t, 38.0x4.3x2.6m, 2b,1vte, 2100hp, 26.2kts, 21p; 2x1-37/20, (1+1x2)-450TT
	Tumleren	3	5	Tumleren	1911		271t, 56.4x5.8x2.2m, 2b,1t, 5000hp, 27.5kts, 33p; 2x1-75/55, (1+4x1)-450TT
			6	Vindhunden	1912		
			7	Spækhuggeren	1912		
	Søridderen	3	8	Søridderen	1911		295t, 55.4x5.5x2.0m, 2b,1t, 5000hp, 27.5kts, 33p; 2x1-75/55, (1+4x1)-450TT
			9	Flyvefisken	1911		
			10	Søulven	1911		
	Hvalrossen	3	11	Hvalrossen	1913		182t, 45.2x5.2x2.1m, 2b,2vte, 3500hp, 26.3kts, 30p; 1x1-75/55, (1+1x2+1x1)-450TT
			12	Delfinen	1914		
			13	Sværdfisken	1914		
	Springeren	10	14	Springeren	1917		109t, 38.5x4.3x2.7m, 2b,1vte, 2000hp, 24.6kts, 24p; 2x1-57/44, (1+1x1)-450TT
			15	Støren	1917		
			16	Søløven	1917		
			17	Søhunden	1917		
			18	Havhesten	1917		
			19	Narhvalen	1917		
			20	Makrelen	1918		
			21	Nordkaperen	1918		
			22	Havkatten	1920		
			23	Sælen	1920		
Nr.4	4	24-27	P4-7	1889-1890	No picture	20t, 20.0m	
Nr.8	2	28, 29	P8, 9	1894-1895	No picture	48t, 25.6x3.8x1.8m, 330hp, 25p; 1x1-47/44, 1x5-37/30, 1x1-356TT	

## SUBMARINES

SS	Havmanden	6	1	Havmanden	1912		164/204t, 38.8x3.6x2.3m, 1d/2em(1), 430(1,3,4)-450(2,5,6)/270(1,3,4)-275(2,5,6)hp, 13/10kts, 10p; 2-450TT
			2	Havfruen	1913		
			3	Thetis	1912		
			4	2den April	1913		
			5	Najaden	1913		
			6	Nymfen	1914		
	7	Ægir	1915				
	8	Ran	1915				

Ægir	5	9	Triton	1916		185/235t, 40.6x3.7x2.4m, 2d/2em(1), 450/340hp, 13.5/9.8kts, 11p; 1x1-57/44, 3-450TT
		10	Neptun	1916		
		11	Galathea	1917		
Rota	3	12	Rota	1920		301/369t, 47.5x4.8x2.7m, 2d/em, 900/640hp, 14.5/10.5kts, 17p; 1x1-57/44, 4-450TT
		13	Bellona	1921		
		14	Flora	1922		

## ESCORTS

FPV	Beskytteren	1	1	Beskytteren	1900		415t, 43.4x7.6x3.8m, 2b,1vte, 625hp, 11kts, 47p; 1x1-47/44, 2x1-37/23
	Islands Falk	1	2	Islands Falk	1906	No picture	760t, 56.0x8.9x5.2m, 2b,1vte, 1100hp, 13kts, 63p; 2x1-75/55, 2x1-47/44
	Diana	1	3	Diana	1917	No picture	288t, 35.5x6.6x3.0m, 400hp, 10.5kts, 27p; 2x1-47/44
AFPV	-	1	1	Fenris	1915		148t

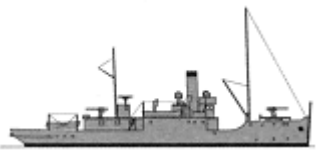

## MINE WARFARE SHIPS

ML	Lossen	1	1	Lossen	1911		640t, 48.6x8.5x3.1m, 2b,2vte, 900hp, 13kts, 53p; 2x1-57/44, 180m
	Minekran Nr.V	2	2	Minekran Nr.V	1917	No picture	186t, 27.0x6.3x2.0m, 2dg, 2em, 290hp, 26p; 2x1-37/38, 60m
			3	Minekran Nr.VI	1919		

[home](#)[World navies yesterday](#)[1925](#)

## Ecuador 01 January 1925

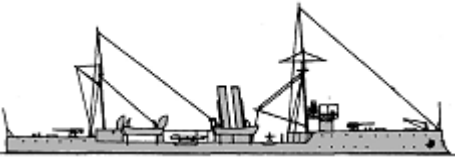
### TORPEDO SHIPS

PGT	Libertador Bolívar	1	1	Libertador Bolívar	1896		800t, 73.2x8.4x4.3m, 4b,2vte, 4500hp, 21.5kts; steel; 25side, 25deck, 25CT; 2x1-120/40, 4x1-47/40, (1+2x1)-450TT
TB	Tarqui	1	1	Tarqui	1890s		56t

### OTHER FIGHTING SHIPS

APG		-	1	1	Cotopaxi	1884	300t; 4x1-76/40
-----	--	---	---	---	----------	------	-----------------



© Ivan Gogin, 2012-15



[home](#)[World navies yesterday](#)[1925](#)

## Egypt 01 January 1925

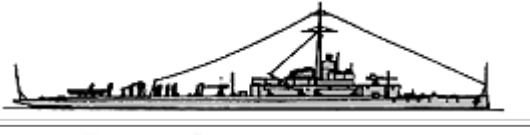
### ESCORTS

SL	Sollum	1	1	Sollum	1917		1493t, 80.0x10.7x3.5m, 2b,1vte, 2500hp, 17.5kts, 77p; 1x1-76/40
FS	Raqib	1	1	Raqib	1917		613t, 74.5x7.2x2.4m, 2b,2t, 3500hp, 20kts, 54p; 1x1-102/40, 1x1-40/39, 2x1-356TT, 2DCR
PC	Noor El Bahr	1	1	Noor El Bahr	1884		450t

### OTHER FIGHTING SHIPS



PGR	Tamai	3	1-3	Hafir, Metemmeh, Abu Klea	1884-1885	No picture	74t, sw; 1x1-76/40
	El Zafir	3	4	El Zafir	1896/97	No picture	128t, sw; 1x1-76/40
			5	El Fateh	1896/97		
			6	El Nasir	1896/97		
	Sheik	2	7	Sultan	1896/97	No picture	140t, 1vte; 1x1-76/40
			8	Melik	1896/97		



[home](#)[World navies yesterday](#)[1925](#)

## Estonia 01 January 1925

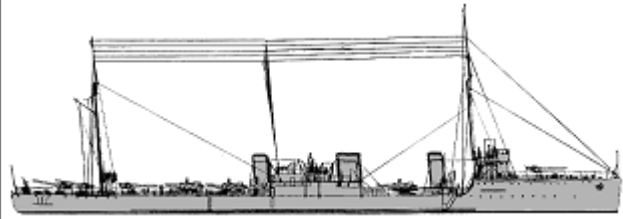
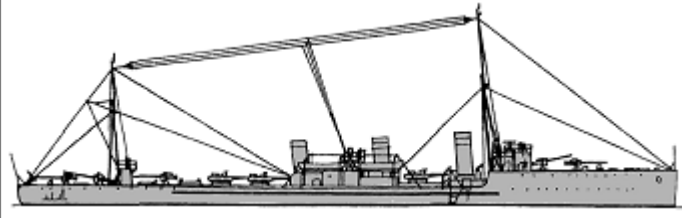
### TORPEDO SHIPS



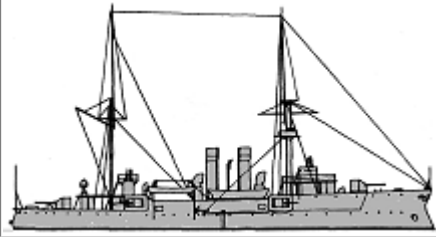
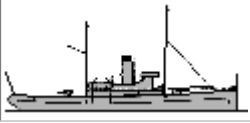

DD	Wambola	1	1	Wambola	1917		1450t, 98.0x9.3x3.9m, 4b,2t, 31500hp, 34kts, 150p; 4x1-102/60, 1x1-40/39, 3x3-450TT, 80m
	Lennuk	1	2	Lennuk	1917		1570t, 107.0x9.5x4.1m, 5b,2t, 32700hp, 35kts, 150p; 5x1-102/60, 1x1-76/30, 3x3-450TT, 80m
TB	Sulev	1	1	Sulev	1916		286t, 50.0x5.3x2.3m, 1b,1gt, 3250hp, 24kts, 35p; 2x1-75/50, 1x2-450TT, 10m

### OTHER FIGHTING SHIPS

PG	Lembit	1	1	Lembit	1907		1200t, 66.5x11.0x2.2m, 4b,2vte, 800hp, 12kts, 148p; 2x1-120/45, 4x1-75/50, 40m
	Laine	1	2	Laine	1913		211t, 37.0x6.1x1.8m, 1b,1vte, 500hp, 12kts, 20p; 2x1-76/30
			1	Ahti	1908		115t

APGR	-	3	2	Mardus	1911		150t; 2x1-75/50
			3	Tartu	1897		110t

## MINE WARFARE SHIPS

AML	-	2	1	Ristna	1906		600t; 175m
			2	Suurop	1906		600t; 175m
MSB	Kalev	2	1, 2	Kalev, Tahkona	1914		34t, 20.7x5.0x1.2m, 2sd, 60hp, 7.2kts, 8p; 25m, MS
	Olev	2	3, 4	Olev, Lehtma	1916 - 1917		46t, 23.2x5.0x1.1m, 2sd, 60hp, 7.2kts, 8p; 40m, MS

## BOARD GUARD SHIPS

ABGS	-	1	1	Kou	1909		100t
------	---	---	---	-----	------	--	------

[home](#)[World navies yesterday](#)[1925](#)

## Finland 01 January 1925

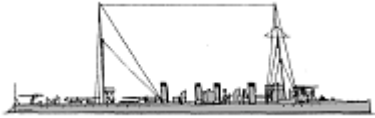

### TORPEDO SHIPS

DD	S1	3	1	S1	1902		305t, 58.5(1)-57.9(2,3)x5.7x2.3m, 4b(1,2)-8b(3),2vte, 3800hp, 27kts, 58p; 2x1-75/50, 10m, MS
			2	S2	1902		
			3	S5	1902		

### ESCORTS

PC	Klas Horn	2	1	Klas Horn	1892		432t, 60.2x7.4x3.3m, 2b,1vte, 3500hp, 22kts, 65p; 2x1-102/60(1), 2x1-75/50(2)
			2	Matti Kurki	1892		

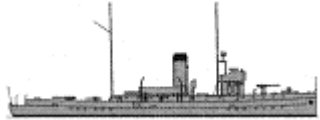
### OTHER FIGHTING SHIPS





PG	Karjala	2	1	Karjala	1918		342t, 50.1x6.8x2.3m, 2b,2vte, 1150hp, 15kts, 48p; 2x1-75/50, 1x1-40/39, 30m
			2	Turunmaa	1918		
	Hämeenmaa	2	3	Hämeenmaa	1918		530t, 52.0x7.5x3.4m, 3b,2vte, 1400hp, 15kts, 55p; 2x1-102/60, 1x1-40/39
			4	Uusimaa	1918		

### COASTAL FORCES

PT	MTV1	2	1, 2	MTV1, 2	1918		13t, 16.4x2.8x1.4m, 2pe/em, 500/10hp, 26.5kts, 8p; 2-450TT
----	------	---	------	---------	------	---	--

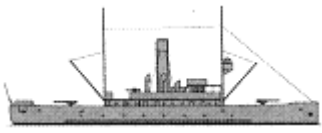
### MINE WARFARE SHIPS AND CRAFTS

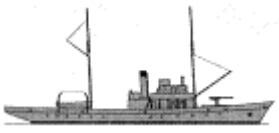
--	--	--	--	--	--	--	--

ML	M1	1	1	M1	1916		776t, 50.0x8.0x2.7m, 3b,1vte, 800hp, 12kts, 46p; 2x1-75/50, 150m
MLB	T15	3	1-3	T15, 16, 21	1914		60t, 20.7x5.0x1.2m, 2sd, 60hp, 7.2kts, 8p; 30m
	T17	2	4, 5	T17, 22	1916		80t, 23.2x5.0x1.1m, 2sd, 60hp, 7.2kts, 8p; 45m
MS	T1	2	1	T1	1918		220t, 43.6x6.1x1.7m, 2b,2vte, 400hp, 11kts, 35p; 1x1-75/50, 1x1-47/43, MS
			2	T2	1917		
MSB	A8	27	1-27	A8, 9, 11-21, 24, 35-45, MP1, 5	1916 - 1917	No picture	20t, 19.8x3.6x1.2m, 1pe, 10kts; MS
	AF1	5	28-32	AF1-5	1917 - 1918		25t, 15.3x3.5xm, 1pe, 50hp, 9kts, 8p; MS
	BVA	4	33-36	BVA, BVB, BVC, BVD	1910		25t, 22.2x3.1x0.5m, 2pe, 200hp, 14.5kts, 12p; 8belt, 8deck, 8CT; 1x1-76/16, MS

[home](#)[World navies yesterday](#)[1925](#)

## France 01 January 1925

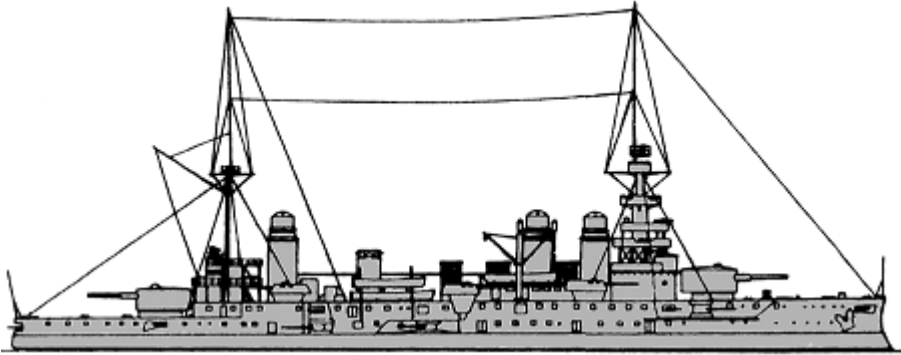
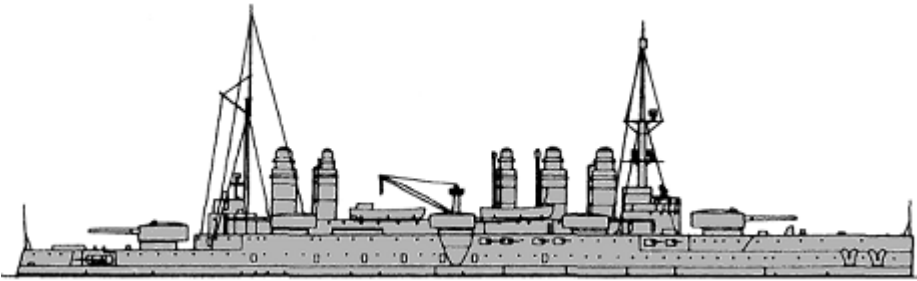
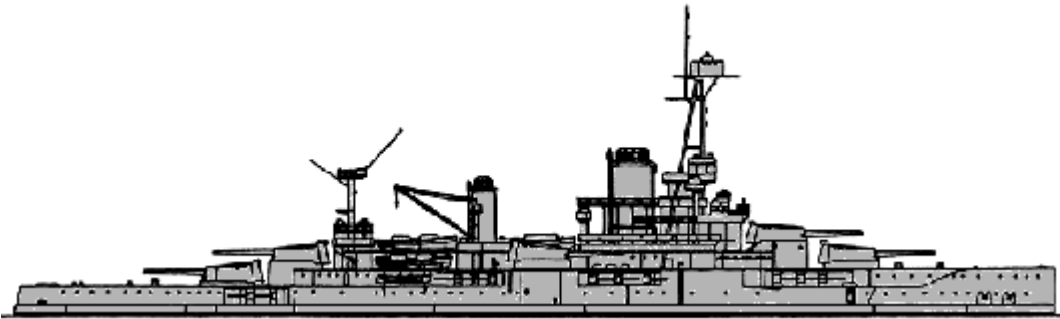

*IN SERVICE: 4 battleships-predreadnoughts, 6 battleships, 12 armoured cruisers, 1 protected cruiser, 4 light cruisers, 57 destroyers, 15 torpedo boats, 46 submarines, 8 sloops, 71 escort gunboats, 31 submarine chasers, 48 patrols, 4 river gunboats, 9 minesweepers, 1 minesweeping trawler*

### CAPITAL SHIPS

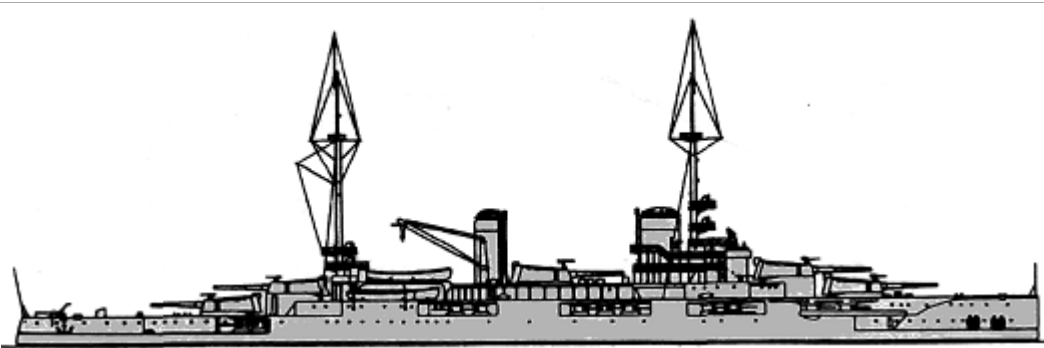

	République	1	1	Patrie (TS)	1906		14900t, 140.0x24.3x8.4m, 24b,3vte, 18000hp, 19kts, 825p; 280belt, 55deck, 360turrets, 300CT; 2x2-305/40, 6x2-164/45, 25x1-47/50, 2-450TT
	Danton	2		Condorcet	1911		19763t, 146.6x25.8x9.2m, 26b,4t, 22500hp, 19.2kts, 921p; 270belt, (48+45)deck, 300turrets, 300CT; 2x2-305/45, 6x2-240/50, 28x1-75/65, 10x1-47/50, 2-450TT
		3		Diderot	1911		
		4		Voltaire	1911		
BB	Courbet	5		Courbet	1913		26000t, 168.0x27.9x9.0m, 26b,4t, 28000hp, 20kts, 1108p; 270belt, (70+40)deck, 320turrets, 300CT; 6x2-305/45, 22x1-139/55, 4x1-47/50, 4-450TT
		6		Jean Bart	1913		
		7		Paris	1914		
		8		Bretagne	1915		

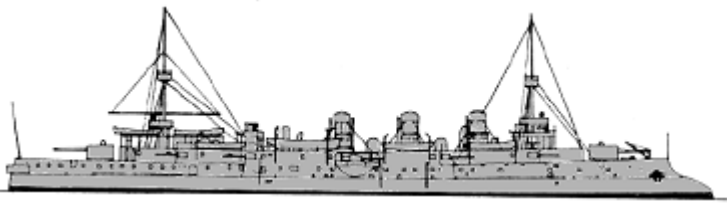
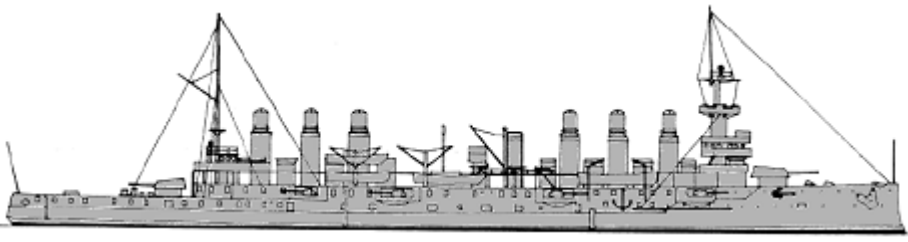
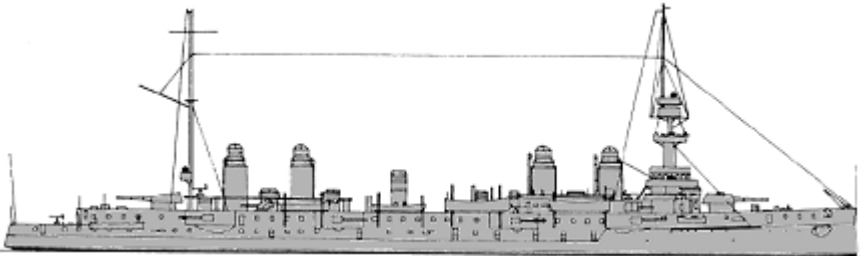
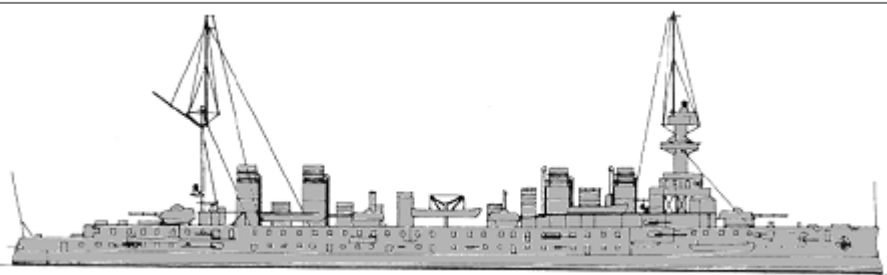
Bretagne	3	9	Provence	1915		<p>25000t, 166.0x26.9x9.8m, 24b(8,10)-18b(9),4t, 29000hp, 20kts, 1133p; 250belt, (45+40)deck, 400-250turrets, 300CT; 5x2-340/45, 18x1-139/55, 4x1-75/65, 4x1-47/50, 4-450TT, 30m</p>
		10	Lorraine	1916		

## CRUISERS

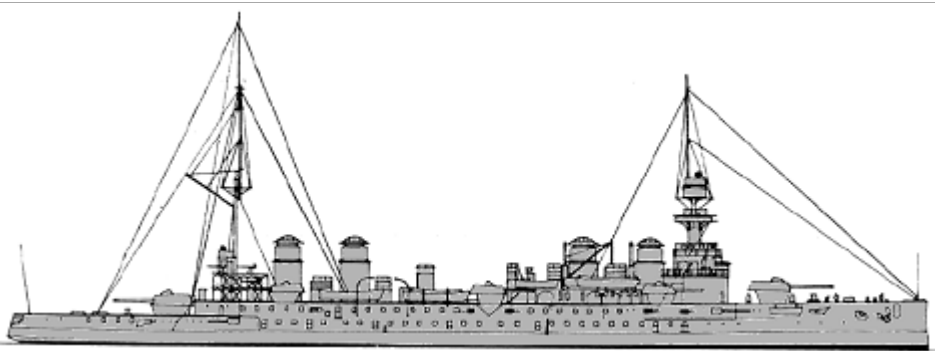
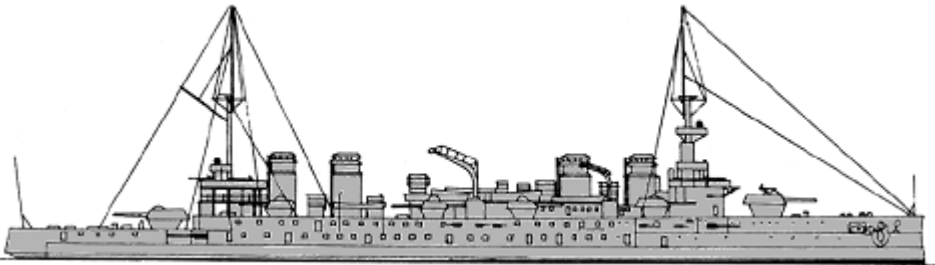
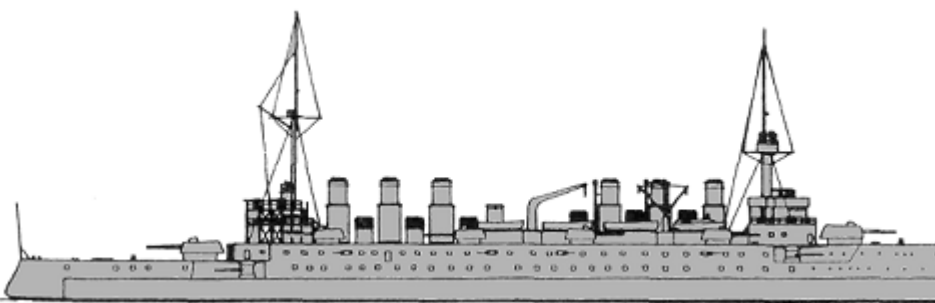
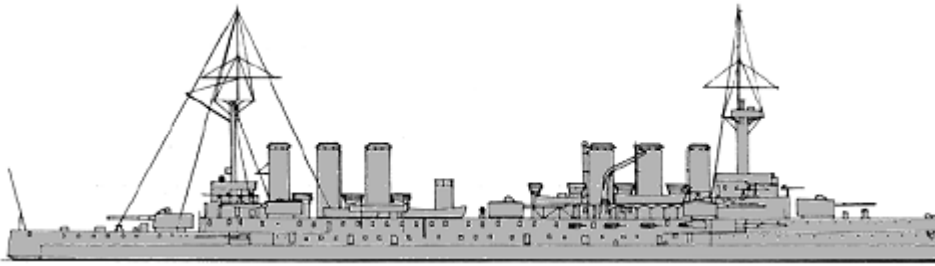
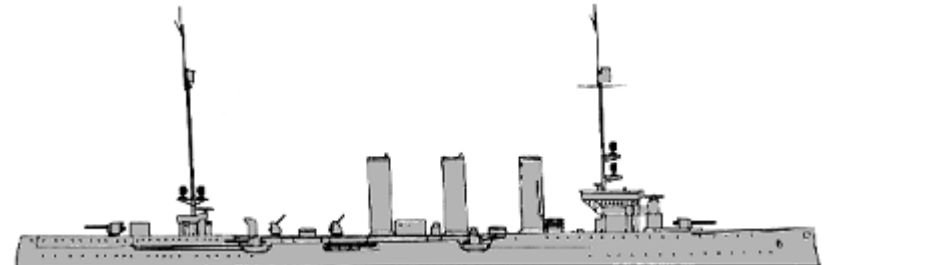

CA	Pothuau	1	1	Pothuau (TS)	1897		<p>5374t, 113.0x15.3x6.5m, 18b,2vte, 10000hp, 19kts, 459p; NS- 60belt, 85deck, 170turrets, 230CT; 2x1-194/40, 8x1-139/45, 2x1-75/55, 10x1-47/40, 8x1-37/23, 4-450TT</p>
	Jeanne d'Arc	1	2	Jeanne d'Arc	1903		<p>11092t, 145.4x19.4x8.1m, 36b,3vte, 33000hp, 21.8kts, 651p; h: 150belt, 65deck, 160turrets, 150CT; 2x1-194/40, 14x1-139/45, 16x1-47/40, 6x1-37/23, 2-450TT</p>
	Gueydon	2	3	Montcalm	1902		<p>9177(3)-9548(4)t, 138.0x19.4x7.7m, 20b(3)-28b(4),3vte, 19600hp, 21kts, 566p; h: 150belt, 55deck, 200turrets, 160CT; 2x1-194/40, 8x1-164/45, 4x1-100/45, 16x1-47/40, 4x1-37/23, 2-450TT</p>
			4	Gueydon	1903		
	Gloire	2	5	Marseillaise	1903		<p>9458(5)-10212(6)t, 139.8x20.2x7.7m, 24b(5)-28b(6),3vte, 21800hp, 21.5kts, 615p; h: 150belt, (46+36)deck, 173turrets, 150CT; 2x1-194/40, 8x1-164/45, 6x1-100/45, 18x1-47/40, 2-450TT</p>
6			Condé	1904			
Léon Gambetta	2	7	Jules Ferry	1905		<p>12379(7)-13108(8)t, 146.5x21.4x8.4m, 20b(7)-28b(8),3vte, 28500hp, 22.5kts, 728p; 150belt, (65+35)deck, 200turrets, 200CT; 2x2-194/40, (6x2+4x1)-164/45, 18x1-47/40(7), 4x1-47/50(7), 22x1-47/50(8), 2x1-37/23, 2-450TT</p>	
8	Victor Hugo	1907					



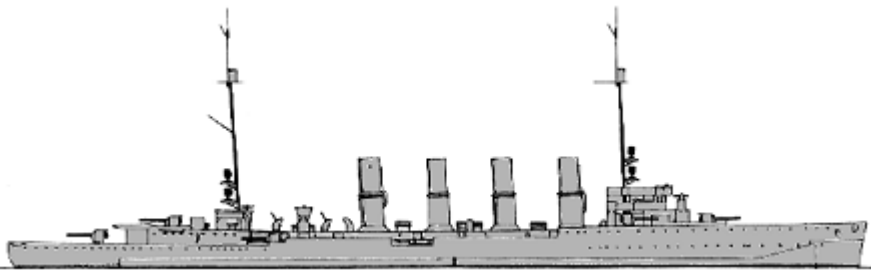
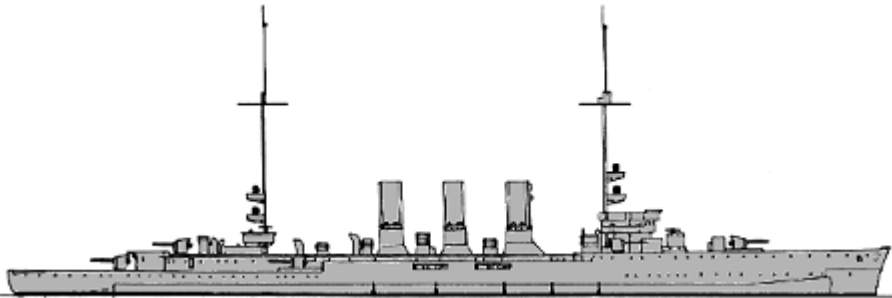
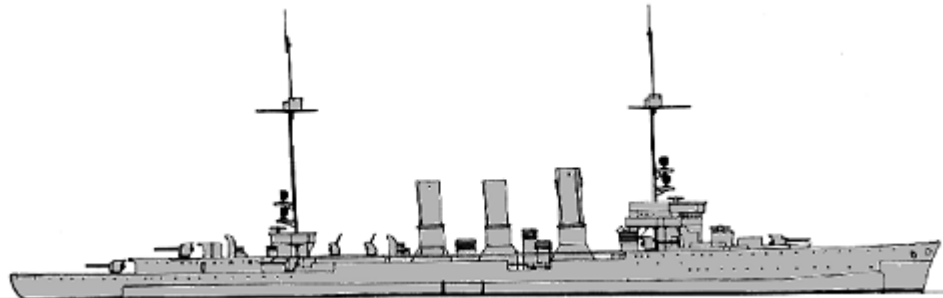
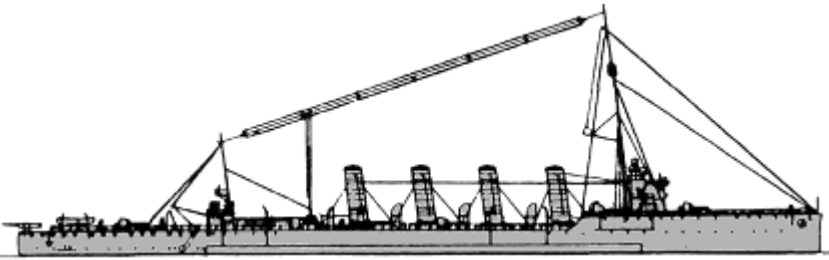







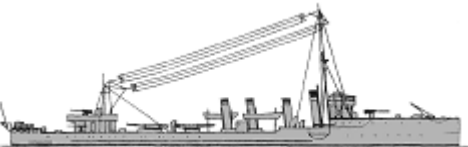
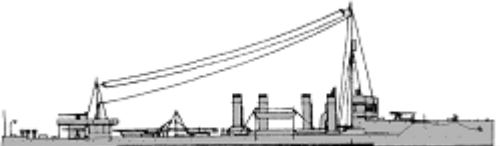

						
Jules Michelet	1	9	Jules Michelet	1908		13105t, 146.5x21.4x8.4m, 28b,3vte, 30000hp, 22.5kts, 770p; 150belt, (65+35)deck, 200turrets, 200CT; 2x2-194/50, 12x1-164/45, 16x1-47/50, 2-450TT
Ernest Renan	1	10	Ernest Renan	1909		13504t, 159.0x21.3x8.4m, 42b,3vte, 36000hp, 23kts, 824p; 150belt, (65+35)deck, 200turrets, 200CT; 2x2-194/50, 12x1-164/45, 18x1-65/50, 8x1-47/50, 2x1-37/23, 2-450TT, kite balloon
Edgar Quinet	2	11	Edgar Quinet	1911		13847(11)-13995(12)t, 158.9x221.5x8.4m, 40b(11)-42b(12),3vte, 36000hp, 23kts, 892p; 150belt, (65+35)deck, 200turrets, 200CT; (2x2+10x1)-194/50, 22x1-65/50, 4x1-47/50, 2-450TT
		12	Waldeck-Rousseau	1911		
Colmar	1	1	Colmar	1910		4915t, 130.5x14.0x5.4m, 15b,4t, 30400hp, 26.3kts, 367p; 40deck, 50shields, 100CT; 6x1-150/45, 2x1-88/45, 2x1-500TT, 2-450TT, 100m
Mulhouse	1	2	Mulhouse	1912		5587t, 138.7x13.5x4.5m, 16b,2t, 25000hp, 27kts, 354p; 60belt, 40deck, 50shields, 100CT; 7x1-150/45, 2x1-88/45, 2x1-500TT, 120m

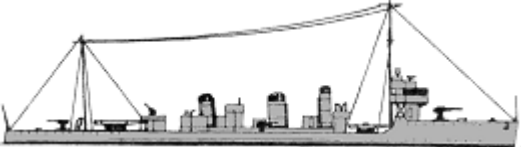
						
CL	Strasbourg	1 3	Strasbourg	1915		6382t, 142.7x13.8x5.8m, 12b,2t, 29000hp, 28kts, 385p; 60belt, 40deck, 50shields, 100CT; 7x1-150/45, 2x1-88/45, 4x1-500TT, 120m
	Metz	1 4	Metz	1916		7125t, 151.4x14.2x6.0m, 12b,2t, 45900hp, 27.8kts, 475p; 60belt, 40deck, 50shields, 100CT; 8x1-150/45, 2x1-88/45, (2+2x1)-500TT, 200m
	Thionville	1 5	Thionville	1915		4010t, 130.6x12.8x5.3m, 16b,2t, 30178hp, 27kts, 340p; 60belt, 20deck, 40shields, 50CT; 9x1-100/50, 1x1-66/50, 1x1-47/44, 3x2-533TT

TORPEDO SHIPS

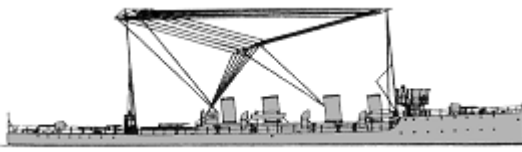
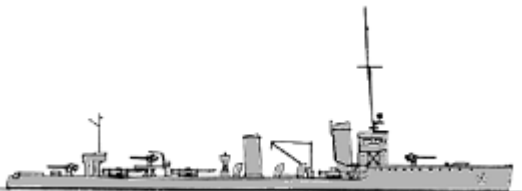
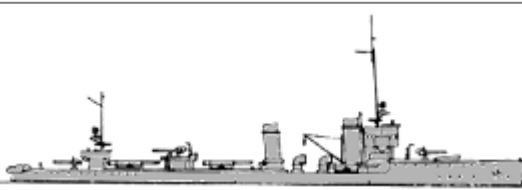

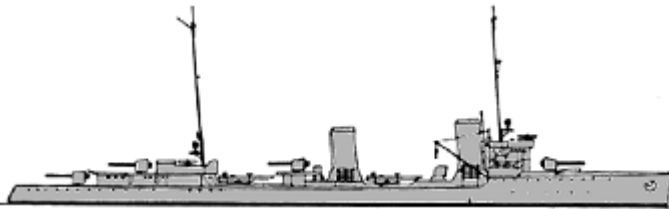
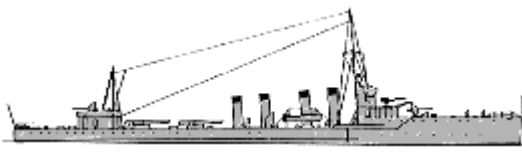



Claymore	5	2	Claymore	1906		356t, 58.0x6.5x3.0m, 2b,2vte, 6800hp, 28kts, 60p; 1x1-65/50, 6x1-47/50, 2x1-450TT
		1	Mortier	1908		
		3	Carquois	1908		
		4	Trident	1909		
		5	Massue	1909		
Branlebas	4	6	Sape	1908		344t, 57.9x6.7x2.4m, 2b,2vte, 6800hp, 27.5kts, 60p; 20belt; 1x1-65/50, 6x1-47/50, 2x1-450TT
		7	Fanfare	1908		
		8	Glaive	1910		
		9	Poignard	1910		
		10	Spahi	1910		



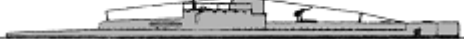

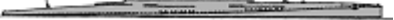

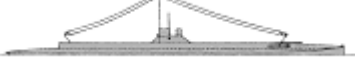
DD	Spahi	5	11	Lansquenet	1910		550t, 64.6(10)-64.0(11,13,14)-65.8(12)x6.1(10)-6.6(11-14)x2.3(10,11,13,14)-2.4(12)m, 4b,2vte, 9000(10)-7500(11-14)hp, 28kts, 79p; 6x1-65/50, (1+2x1)-450TT
			12	Mameluk	1911		
			13	Enseigne Henry	1912		
			14	Aspirant Herber	1912		
	Chasseur	1	15	Cavalier (TS)	1911		520t, 64.2ppx6.6x3.1m, 4b,3t, 7200hp, 28kts, 79p; 6x1-65/50, 2x1-450TT
	Bouclier	8	16	Bouclier	1911		820t, (72.3-78.3)x(7.6-8.0)x(2.8-3.3)m, 4b,3t(16,17)-2t(18-23), 13000hp, 30kts, 83p; 2x1-100/45, 1x1-75/35, 4x1-65/50, 2x2-450TT, 2DCR
			17	Casque	1911		
			18	Cimeterre	1912		
			19	Capitaine Mehl	1912		
			20	Commandant Bory	1913		
			21	Commandant Rivière	1913		
			22	Dehorter	1913		
	Bisson	5	24	Bisson	1913		855t, 78.1x8.6x3.1m, 4b,2t, 15000hp, 30kts, 83p; 2x1-100/45, 1x1-75/35, 4x1-65/50, 2x2-450TT, 2DCR
			25	Commandant Lucas	1914		
26			Protet (TS)	1914			
27			Mangini	1914			
28			Magon	1914			
Aventurier	4	29	Opiniâtre	1914		1250t, 88.5x8.8x3.1m, 4b(29,31)-5b(30,32),2t, 12000(29,31)-18000(30,32)hp, 22(29,31)-32(30,32)kts, 140p; 4x1-100/45, 1x1-47/50, 4x1-450TT	
		30	Aventurier	1914			
		31	Téméraire	1914			
		32	Intrépide	1914			
Enseigne Roux	2	33	Enseigne Roux	1916		1075t, 82.6x8.6x3.0m, 4b,2t, 17000hp, 30kts, 81p; 2x1-100/45, 1x1-75/35, 4x1-65/50, 2x2-450TT, 2DCR	
		34	Mécanicien Principal Lestin	1916			
Arabe	12	35	Algérien	1917		750t, 83.0x7.3x2.4m, 4b,2vte, 10000hp, 29kts, 86p; 1x1-120/40, 4x1-76/40, 2x2-450TT	
		36	Annamite	1917			
		37	Arabe	1917			
		38	Bambara	1917			
		39	Hova	1917			
		40	Kabyle	1917			
		41	Marocain	1917			
		42	Sakalave	1917			
		43	Sénégalais	1917			
44	Somali	1917					

		45	Tonkinois	1917		
		46	Touareg	1917		
Pierre Durand	1	47	Pierre Durand	1916		1188t, 82.0x8.3x3.4m, 3b,2t, 23500hp, 34kts, 85p; 3x1-105/45, (2x2+2x1)-500TT, 24m
Matelot Leblanc	1	48	Matelot Leblanc	1917		1045t, 85.4x7.8x2.4m, 6b,2t, 22360hp, 32.6kts, 114p; 2x1-100/50, 6x1-66/50, 2x2-450TT
Buino	1	49	Buino	1918		1188t, 82.0x8.3x3.5m, 3b,2t, 23500hp, 34kts, 105p; 3x1-105/45, (2x2+2x1)-500TT, 24m
Chastang	4	50	Chastang	1918		1170t, 83.1x8.3x3.6m, 3b,2t, 24000hp, 32kts, 105p; 3x1-105/45, (2x2+2x1)-500TT, 24m
		51	Vesco	1918		
		52	Mazaré	1918		
		53	Deligny	1918		
Rageot de la Touche	2	54	Rageot de la Touche	1918		1147t, 84.5x8.4x3.4m, 3b,2t/1t(2), 24500hp, 32kts, 105p; 3x1-105/45, (2x2+2x1)-500TT, 24m
		55	Marcel Delage	1920		
Amiral Sénès	1	56	Amiral Sénès	1919		2415t, 106.0x10.2x3.4m, 4b,2t, 45000hp, 36kts, 188p; 4x1-150/45, 2x2-600TT, 40m
Enseigne Gabolde	1	57	Enseigne Gabolde	1923		950t, 83.6x8.2x3.1m, 4b,2gt, 20000hp, 31kts, 80p; 3x1-100/45, 1x1-75/35, 2x2-500TT, 2DCR
Coureur	1	1	Grondeur	1892		131t, 45.1x4.4x1.4m, 2b,2vte, 1750hp, 23.5kts; 2x1-47/40, 2-350TT
Mistral	5	2	Mistral	1901		183t, 45.0x5.2x1.6m, 2b,2vte, 4200hp, 26kts, 30p; 24belt, 9deck; 2x1-47/40, 2x1-380TT
		3	Siroco	1901		
		4	Simoun	1901		
		5	Trombe	1902		
		6	Typhon	1903		

TB	No295	7	No310	1906		101t, 38.0x4.4x1.9m, 2b,1vte, 2000hp, 26kts, 23p; 1x1-75/35, 2x5-37/20, 1-450TT
		8	No328	1907		
		9	No330	1908		
		10	No332	1907		
		11	No337	1908		
		12	No339	1906		
		13	No349	1906		
		14	No368	1907		
		15	No369	1908		

## SUBMARINES

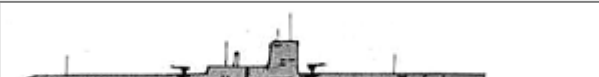
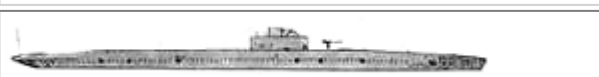

Brumaire	4	1	Brumaire	1913		397/551t, 52.1x5.1x3.1m, 2d/em, 840/660hp, 13/8.8kts, 29p; 1x1-88/30(2), 1x1-47/50(1,3,4), 7-450TT
		2	Curie	1914		
		3	Le Verrier	1914		
		4	Newton	1914		
Gustave Zédé	2	5	Gustave Zédé	1914		849(5)-820(6)/1098(5)-1047(6)t, 74.0x6.0x3.7m, 2d/em, 2400/1640hp, 15(5)-17.3(6)/11.4(5)-10.5(6)kts, 47p; 1x1-75/35, 1x1-47/50, 8-450TT(5), (8+1x2)-450TT(6)
		6	Néréide	1916		
Amphitrite	7	7	Amphitrite	1915		414(7-11)-440(12,13)/609(7-11)-610(12,13)t, 53.9x5.4x3.3m, 2d/em, 800/700hp, (12-13)/9.5kts, 29p; 1x1-75/35, 8-450TT, 12m(12,13)
		8	Artémis	1915		
		9	Atalante	1915		
		10	Andromaque	1916		
		11	Aréthuse	1916		
		12	Amarante	1918		
		13	Astrée	1918		
Clorinde	2	14	Clorinde	1916		413/567t, 53.9x5.1x3.4m, 2d/em, 800/700hp, 13/9kts, 29p; 1x1-75/35, 8-450TT
		15	Cornélie	1917		
Bellone	3	16	Bellone	1916		523/788t, 60.6x5.4x3.5m, 2d/em, 1640/800hp, 14.7/9.5kts, 38p; 1x1-75/35, 8-450TT
		17	Gorgone	1916		
		18	Hermione	1917		
Dupuy de Lôme	2	19	Dupuy de Lôme	1916		833/1287t, 75.0x6.4x3.6m, 2d/em, 2400/1640hp, 15/11kts, 43p; 1x1-75/35, 1x1-47/50, 8-450TT
		20	Sané	1916		
Diane	1	21	Daphné	1916		633/891t, 68.0x5.5x3.7m, 2d/em, 1800/1400hp, 17/11.5kts, 43p; 1x1-75/35, 10-450TT
Armide	3	22	Armide	1916		457/670t, 56.2x5.2x3.0m, 2d/em, 2200/900hp, 17.5/11kts, 31p; 1x1-75/35(23), 1x1-47/50(22,24), 6-450TT(22), 4-450TT(23,24)
		23	Amazone	1917		
		24	Antigone	1917		
Roland Morillot	1	25	Roland Morillot	1916		265/291t, 36.1x4.4x3.7m, 2d/2em(1), 270/280hp, 8.9/5.7kts, 23p, 50m; 1x1-50/40, 2-500TT
		26	Lagrange	1918		

SS	Lagrange	4	27	Romazotti	1918		920/1318t, 75.2x6.3x3.6m, 2d/em, 2600/1640hp, 16.5/11kts, 47p; 2x1-75/35, 8-450TT
			28	Laplace	1921		
			29	Regnault	1924		
	Victor Réveille	1	30	Victor Réveille	1916		755/832t, 56.8x5.9x4.9m, 2d/em, 900/800hp, 9.9/7.8kts, 32p, 50m; 1x1-105/45, 2-500TT, 38m
	Jean Autric	2	31	Jean Autric	1917		798/1000t, 71.6x6.3x3.9m, 2d/em, 2400/1200hp, 16.4/8.4kts, 36p, 50m; 1x1-105/45, 1x1-88/30, 6-500TT
			32	Léon Mignot	1917		
	René Audry	1	33	René Audry	1918		1164/1512t, 81.5x7.4x4.2m, 2d/em, 2400/1200hp, 14.7/7kts, 40p, 75m; 1x1-150/45, 4-500TT, 72m
	Halbronn	1	34	Halbronn	1918		1930/2483t, 92.0x9.1x5.3m, 2d+1dg/2em(2), (3500+450)/1780hp, 15.8/7.6kts, 62p, 75m; 60CT; 2x1-150/45, 6-500TT
	Pierre Marrast	2	35	Pierre Marrast	1918		821/1002t, 71.6x6.3x3.9m, 2d/em, 2400/1230hp, 16.2/8.2kts, 39p, 50m; 1x1-105/45, 6-500TT
			36	Jean Roulier	1919		
	Trinité-Schillemans	2	37	Trinité-Schillemans	1918		510/640t, 55.5x5.8x3.7m, 2d/em, 1100/788hp, 13/7.4kts, 34p, 75m; 1x1-105/45, 5-500TT
			38	Carrisan	1918		
	Jean Corre	1	39	Jean Corre	1919		539/656t, 55.5x5.8x3.9m, 2d/em, 1060/788hp, 13.5/7.5kts, 34p, 75m; 1x1-105/45, 5-500TT
Fulton	2	40	Fulton	1920		870/1247t, 74.0x6.4x3.6m, 2d/em, 2700/1640hp, 16.5/11kts, 47p; 2x1-75/35, 8-450TT	
		41	Joessel	1920			
O'Byrne	3	42	O'Byrne	1921		342/513t, 52.4x4.7x2.7m, 2d/em, 1020/400hp, 14/8kts, 25p; 1x1-47/50, 4-450TT	
		43	Henry Fournier	1921			
		44	Louis Dupetit-Thouars	1921			
Maurice Callot	1	45	Maurice Callot	1922		931/1298t, 75.5x6.7x3.5m, 2d/em, 2900/1640hp, 16.5/10.5kts, 48p; 1x1-75/35, 6-450TT, 27m	
Pierre Chailley	1	46	Pierre Chailley	1922		884/1191t, 70.0x7.5x4.0m, 2d/em, 1800/1400hp, 13.7/8.5kts, 44p; 1x1-100/45, 4-450TT, 40m	

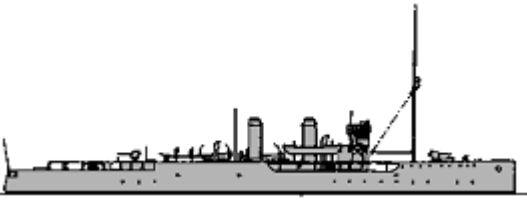
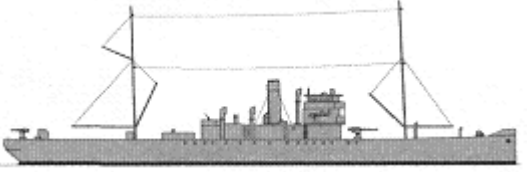
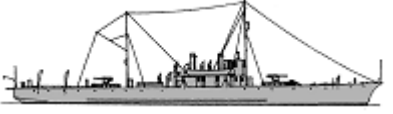
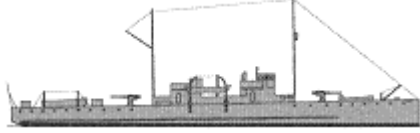
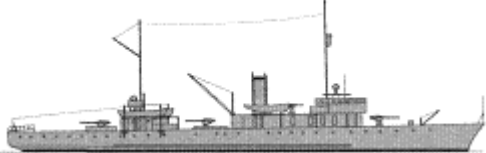

## ESCORTS

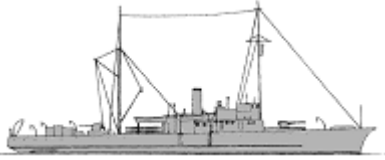
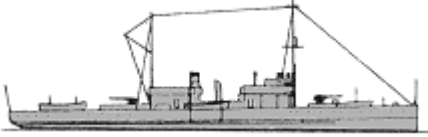
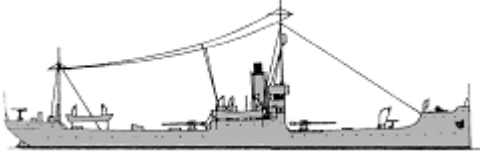
Aldébaran	7	1	Aldébaran	1916		1470t, 81.5x10.5x4.2m, 2b,1vte, 2800hp, 17.5kts, 103p; 2x1-139/45, 2x1-75/35, 2DCT, 1DCR
		2	Algol	1916		
		3	Altair	1916		
		4	Antarès	1916		
		5	Bellatrix	1916		

SL						
		6	Cassiopée	1917		
		7	Régulus	1917		
Andromédé	1	8	Ville d'Ys	1917		 1250t, 83.5x12.0x5.0m, 2b,1vte, 2675hp, 17kts, 103p; 1x1-100/45, 3x1-75/35, 2x1-47/40
Ardent	18	1	Agile	1916		400(1,3,7,9,11,15,16)-410(2,4-6,8,10,12-14,17,18)t, 60.2x7.2x2.9m, 2b,1vte(1,3,7,9,11,15,16)-2vte(2,4-6,8,10,12-14,17,18), 1200-2200hp, 14-17kts, 55-60p; 2x1-145/45(3,11,15), 2x1-100/45(1,2,4-10,12-14,16-18), 2DCT, MS
		2	Alerte	1916		
		3	Ardent	1916		
		4	Belliqueuse	1916		
		5	Capricieuse	1916		
		6	Curieuse	1916		
		7	Emporté	1916		
		8	Gracieuse	1916		
		9	Inconstant	1916		
		10	Malicieuse	1916		
		11	Sans Souci	1916		
		12	Audacieuse	1917		
		13	Batailleuse	1917		
		14	Dédaigneuse	1917		
		15	Étourdi	1917		
		16	Éveillé	1917		
		17	Impétueuse	1917		
		18	Tapageuse	1917		
Friponne	4	19	Bouffonne	1917		315t, 66.4x7.0x2.8m, 2d, 900hp, 14.5kts, 54p; 2x1-100/45, 2DCT
		20	Diligente	1918		
		21	Engageante	1918		
		22	Surveillante	1918		
Marne	6	23	Marne	1917		601(23)-566(24-28)t, 78.0x8.9x3.4m, 2b,2gt, 5000(23)-4000(24-28)hp, 21(23)-20(24-28)kts, 113p; 4x1-100/45, 1x1-75/35(25), 2x1-65/50(23,24,26-28), 1DCR
		24	Oise	1917		
		25	Somme	1917		
		26	Yser	1917		
		27	Aisne	1918		
		28	Meuse	1918		
Luronne	1	29	Luronne	1917		400t, 60.2x7.2x2.9m, 2d, 630hp, 13.7kts, 54p; 2x1-100/45, 2DCT

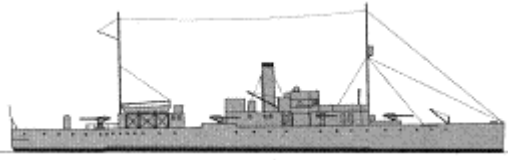
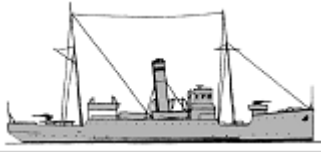
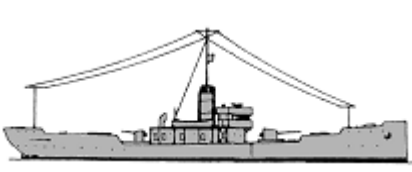

						
Conquérante	2	30	Conquérante	1917		457t, 66.4x7.9x2.8m, 2d, 1800hp, 17kts, 54p; 2x1-100/45, 2DCT
		31	Valliante	1917		
FS  Amiens	29	32	Arras	1918		850t, 74.9x8.7x3.2m, 2b,2gt, 5000hp, 20kts, 103p; 2x1-139/55, 1x1-75/35, 2DCT, 1seaplane (F.B.A.17(37))
		33	Dunkerque	1918		
		34	Reims	1918		
		35	Amiens	1920		
		36	Bapaume	1920		
		37	Belfort	1920		
		38	Calais	1920		
		39	Coucy	1920		
		40	Épernay	1920		
		41	Épinal	1920		
		42	Lassigny	1920		
		43	Les Éparges	1920		
		44	Nancy	1920		
		45	Tahure	1920		
		46	Toul	1920		
		47	Vauquois	1920		
		48	Verdun	1920		
		49	Vimy	1920		
		50	Craonne	1921		
		51	Liévin	1921		
52	Lunéville	1921				
53	Montmiral	1921				
54	Péronne	1921				
55	Remiremont	1921				
56	Révigny	1921				
57	Vitry-le-François	1921				
58	Baccarat	1922				
59	Béthune	1922				
60	Montdement	1922				
Ailette	2	61	Ailette	1918		492t, 70.0x8.3x3.1m, 2b,2gt, 4000hp, 20kts, 107p; 4x1-100/45, 2x1-65/50
		62	Escaut	1918		
		63	Ancre	1918		



	Scarpe	3	64	Scarpe	1918		604t, 76.2x8.7x3.3m, 2b,2gt, 5000hp, 20kts, 107p; 4x1-100/45, 1x1-65/50, 2DCT
			65	Suippe	1918		
	Flamant	1	66	Quentin Roosevelt	1918		585t, 50.0x8.4x5.8m, 2b,1vte, 1200hp, 14.5kts, 53p; 1x1-75/35, 1x1-47/50
	Dubordieu	5	67	Du Chaffault	1918		453t, 64.9x8.2x3.1m, 2b,2gt, 2000hp, 16.5kts, 74p; 1x1-139/45, 1x1-100/45, 2DCT
			68	Dubordieu	1918		
69			Dumont D`Urville	1919			
70			Du Couëdic	1920			
			71	Duperré	1920		
SC	C1	15	1 -	C25, 26, 31, 51, 56, 58, 67, 72, 74, 81, 91, 92, 95, 96, 98	1917		85t, 33.5x4.7x2.3m, 3pe, 660hp, 16.5kts, 27p; 1x1-75/35, 1DCT
			15		1918		
	C101	16	16	Ch102	1919		150t, 43.4x5.2x2.4m, 2b,2vte, 1300hp, 16.5kts, 31p; 1x1-75/35, 1DCT
			17	Ch103	1919		
			18	Ch104	1919		
			19	Ch105	1919		
			20	Ch106	1919		
			21	Ch107	1919		
			22	Ch108	1919		
			23	Ch109	1919		
			24	Ch110	1919		
			25	Ch111	1920		
			26	Ch112	1920		
			27	Ch113	1920		
			28	Ch114	1920		
			29	Ch115	1920		
			30	Ch116	1920		
31	Ch117	1920					
Loup	3	1	Loup	1917	No picture	285t, 1b,1vte, 600hp, 10kts; 1x1-75/35	
		2	Marcassin	1917			
		3	Sanglier	1917			
Hippopotame	4	4	Mammoth	1917	No picture	970t, 2b,1vte, 1800hp, 12kts; 2x1-75/35	
		5	Hippopotame	1918			
		6	Rhinocéros	1918			
		7	Mastodonte	1919			
Aurochs	4	8	Zébu	1917	No picture	290t, 1b,1vte, 650hp, 10kts; 1x1-90/24, 1x1-47/40	
		9	Aurochs	1918			

PC		10	Renne	1918			
		11	Élan	1919			
	Clameur	6	12	Fracas	1917	No picture	370t, 2b,1vte, 720hp, 12kts; 1x1-90/24
			13	Clameur	1918		
			14	Tapage	1918		
			15	Tintamarre	1918		
			16	Tumulte	1918		
			17	Vacarme	1918		
	Athlete	2	18	Athlete	1917	No picture	585t, 1b,2vte, 500hp, 12kts; 2x1-120/40
			19	Lutteur	1919		
	Navarin	6	20	Lutzen	1918	No picture	640t, 1vte, 500hp, 11kts, 31p; 1x1-100/45
			21	Malakoff	1918		
			22	Navarin	1918		
			23	Sebastopol	1918		
			24	Seneff	1918		
			25	St-Georges	1918		
	Mauviette	1	26	Passereau II	1918		460t, 43.5x7.3x4.2m, 1b,1vte, 10kts; 1x1-90/24, 1x1-47/40, MS
	Pluvier	9	27	Faisan	1918	No picture	(680-780)t, 1vte, 750hp, 11kts
			28	Gelinotte	1918		
29			Heron II	1918			
30			Paon	1918			
31			Pigeon	1918			
32			Pingouin II	1918			
33			Pintade	1918			
34			Ramier	1918			
35			Tourterelle	1918			
Crabe	11	36	Cèdre	1918	No picture	(360-370)t, 1b,1vte, 400hp, (9-10)kts; 1x1-90/24	
		37	Chêne	1918			
		38	Crabe	1918			
		39	Erable	1918			
		40	Orme	1918			
		41	Tourteau	1918			
		42	Frêne	1919			
		43	Hêtre	1919			
		44	Peuplier	1919			
		45	Calmar	1920			
		46	Homard	1920			
Bouvines	2	47	Fleurus	1919	No picture	684t, 45.0x7.8xm, 1vte, 500hp, 9.5kts; 2x1-100/45	

## OTHER FIGHTING SHIPS

PR	Doudart de la Grée	1	1	Doudart de la Grée	1909		183t, 54.4x6.7x1.0m, 2b,2vte, 900hp, 14kts, 66p; 1x1-75/35, 2x1-37/23
	Balny	1	2	Balny	1920		226t, 54.4x6.7x1.0m, 2b,2vte, 900hp, 14kts, 59p; 1x1-75/35, 2x1-37/23
	Vigilante	2	3	Vigilante	1923		218t, 51.8x7.7x1.2m, 2b,2vte, 600hp, 12kts, 42p; 2x1-75/35, 2x1-37/23
	4		Argus	1923			

## MINE WARFARE SHIPS

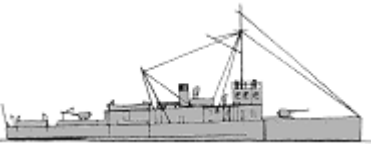
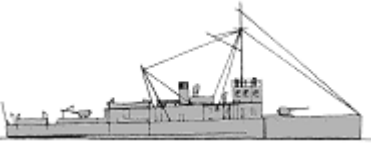
MS	No295	3	1	No315	1905		101t, 38.0x4.4x1.9m, 2b,1vte, 2000hp, 26kts, 23p; 2x5-37/20, 1-450TT, MS
			2	No321	1907		
			3	No327	1907		
	Granit	3	4	Granit	1918		360t, 57.6x7.9x2.3m, 1b,1vte, 600hp, 12.5kts, 63p; 2x1-65/50, MS
			5	Mica	1918		
			6	Porphyre	1918		
	Albâtre	3	7	Meulière	1919		380t, 57.6x7.9x2.3m, 1b,1vte, 500hp, 10.5kts, 63p; 1x1-65/50, MS
			8	Pyrite	1919		
			9	Quartz	1919		
TL	Campanule	1	1	Perce-Neige	1919	No picture	80t, 1pe, 325hp, 13kts; MS

## NAVAL AVIATION (approximately, maximal number of delivered planes signed)

Deck planes	F: 30 D.1ter (delivery till 1925);R: 30 G.L.22 ET.1
Seaplanes	F: 10 Ni-D.32RN, 125 H.D.12; B: 33 F.B.A.17 HMB.2; R: 141 F.B.A.17 HE.2 (delivery till 1931)

[home](#)

[World navies yesterday](#)

[1925](#)

# Germany 01 January 1925

*IN SERVICE: 5 battleships-predreadnoughts, 8 protected cruisers, 32 large torpedo boats, 2 gunboats, 1 fishery protection vessel, 7 motor torpedo boats, 5 motor anti-submarine boats, 34 minesweepers*

## CAPITAL SHIPS

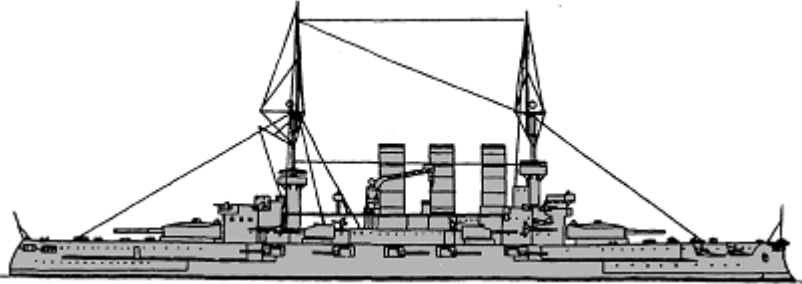
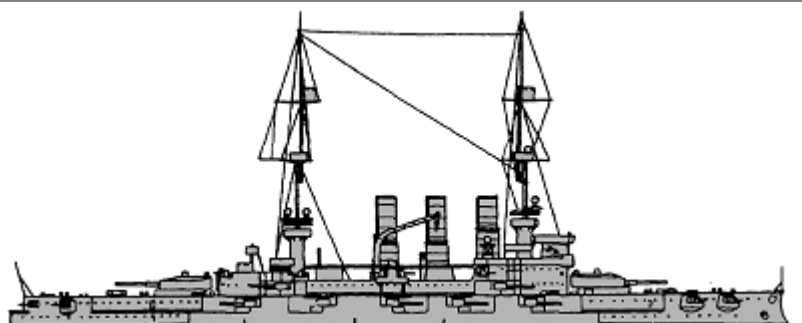



	Braunschweig	1	Braunschweig	1904		14394t, 127.7x25.6x8.1m, 14b,3vte, 17700hp, 18.7kts, 743p; 225belt, 40deck, 250turrets, 300CT; 2x2-283/40, 12x1-173/40(1), 10x1-173/40(2), 8x1-88/45, 2x1-500TT(1), 4x1-500TT(2)
		2	Elsass	1904		
BB	Deutschland	3	Hannover	1907		13994t, 127.6x22.2x8.3m, 12b,3vte, 20540hp, 18.6kts, 743p; 240belt, 40deck, 280turrets, 300CT; 2x2-283/40(3,4), 14x1-173/40(3,4), 6x1-105/45(5), 4x1-88/45(3), 20x1-88/35(4), 4x1-88/35(5), 6-450TT(4)
			Schlesien	1908		
		4	Schleswig-Holstein	1908		
		5				

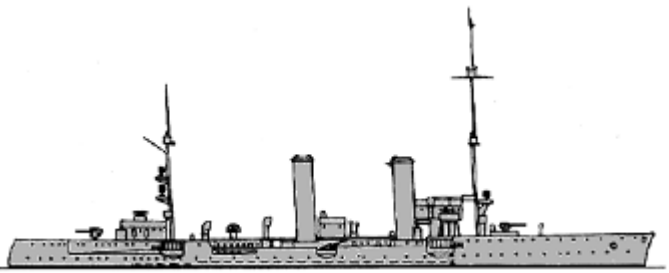
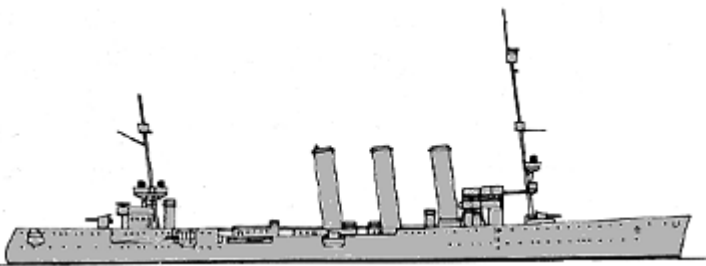

## CRUISERS

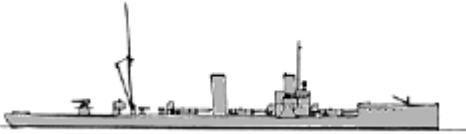
	Gazelle	1	Niobe	1900		2963(1)-3082(2-5)-3180(6)t, 105.0(1,6)-108.7(2,4)-105.1(3,5)x12.2(1-5)-12.4(6)x5.5(1,6)-5.4(2-5)m, 8b(1)-10b(2)-9b(3-6),2vte, 8110(1)-9020(2-5)-8580(6)hp, 22.1(1)-21.8(2-5)-21.5(6)kts, 249(1-5)-259(6)p; 50slopes, 25deck, 50shields, 80CT; 10x1-105/45(1-4), 10x1-105/40(5,6), 2x1-500TT(1,2,4-6), 200m(5,6)
		2	Nymphe	1900		
		3	Thetis	1901		
		4	Amazone	1901		
		5	Medusa	1901		
		6	Arcona	1903		

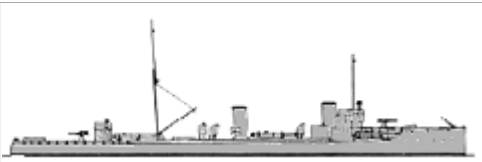

CL						
	Bremen 2	7 Hamburg	1904	8 Berlin	1905	

### TORPEDO SHIPS

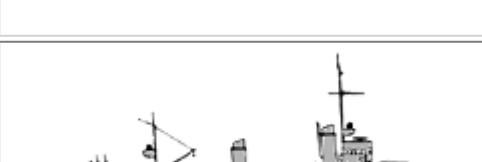
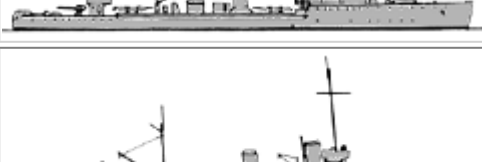
S138	7	1	T139	1907		684t, 70.7x7.8x2.8m, 4b,2vte, 11000hp, 30.3kts, 80p; 2x1-88/45, 3x1-450TT	
		2	T141	1907			
		3	T143	1907			
		4	T144	1907			
		5	T146	1907			
		6	T148	1908			
		7	T149	1908			
V150	8	8	T151	1908		691t, 72.5x7.8x3.0m, 4b,2vte, 10900hp, 30kts, 84p; 2x1-88/45(10-15), 2x1-88/35(9), 1x2-500TT(8,10,12), 3x1-450TT(9,11,13-15)	
		9	T152	1908			
		10	T153	1908			
		11	T154	1908			
		12	T155	1908			
		13	T156	1908			
		14	T157	1908			
		15	T158	1908			
G169	1	16	T175	1910		824t, 74.0x7.9x3.0m, 4b,2t, 15000hp, 32kts, 84p; 2x1-88/45, 4x1-500TT	
TB	V180	2	17	T185	1910		783(17)-775(18)t, 73.9x7.9x3.1m, 4b,2t, 18000hp, 32kts, 84p; 2x1-105/45, 2x2-500TT
			18	T190	1911		
G192	1	19	T196	1911		810t, 74.0x7.9x3.0m, 4b,2t, 18200hp, 32kts, 76p; 2x1-105/45, 2x2-500TT	



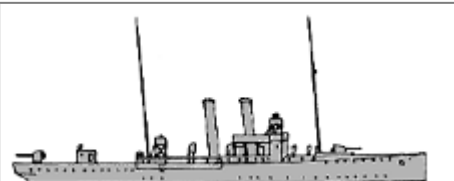
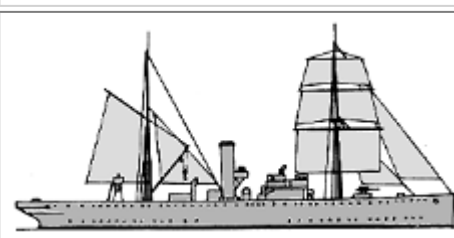

						
S165	1	20	T168	1911		765t, 74.2x7.9x3.0m, 4b,2t, 17500hp, 32kts, 84p; 2x1-88/45, 1x1-88/30, 3x1-450TT
V1	5	21	V1	1912		753t, 71.1x7.6x3.1m, 3b,2t, 17000hp, 32kts, 74p; 2x1-105/45, 2x1-500TT, 18m
		22	V2	1912		
		23	V3	1912		
		24	V5	1913		
		25	V6	1913		
G7	4	26	G7	1912		775t, 71.5x7.6x3.0m, 3b,2t, 16000hp, 31.5kts, 74p; 2x1-105/45, 2x1-500TT, 18m
		27	G8	1912		
		28	G10	1912		
		29	G11	1912		
S13	3	30	S18	1913		749t, 71.5x7.4x2.8m, 3b,2t, 15700hp, 32.5kts, 74p; 2x1-105/45(30,32), 2x1-88/45(31), 2x1-500TT, 18m
		31	S19	1913		
		32	S23	1913		

OTHER FIGHTING SHIPS

PG	Illtis	1	1	Panther	1902		1193t, 66.9x9.7x3.1m, 4b,2vte, 1300hp, 14kts, 130p; 2x1-105/40 (can be fitted)
	Meteor	1	2	Meteor	1924		1504t, 71.1x10.2x4.0m, 2b,2vte, 885hp, 11.5kts, 124p; 1x1-88/45 (can be fitted)
FPV	M57	1	1	Zieten	1919		507(1)-503(2)t, 58.4(1)-58.2(2)x7.3x2.3m, 2b,2vte, 1800(1)-1890(2)hp, 16.5kts, 40p; 3x1-88/45

COASTAL FORCES

--	--	--	--	--	--	--	--

PT	L14	3	1 - 3	LM16, 27, 28	1918 - 1919		7t, 16.5x2.4x0.6m, 3pe, 720hp, 31.6kts, 7p; 1-450TT
	LM17	1	4	LM20	1917		8t, 17.0x2.4x0.6m, 3pe, 720hp, 30.8kts, 7p; 1x1-20/60, 1-450TT
	L21	3	5 - 7	LM21 - 23	1917 - 1919		7t, 16.0x2.4x0.7m, 3pe, 720hp, 31.8kts, 7p; 1x1-20/60(5), 1-450TT
PS	UZ23	5	1 - 5	UZ27 - 29, 34, 35	1918		60t, 31.0x4.4x1.3m, 2pe, 570hp, 16kts, 14p; 1x1-52/55(4), DCR

### MINE WARFARE SHIPS

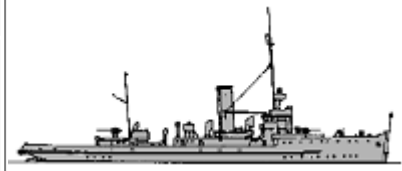
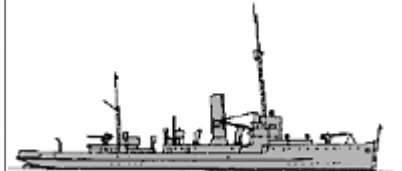
MS	M27	2	1	M28	1916		507(1)-503(2)t, 58.4(1)-58.2(2)x7.3x2.3m, 2b,2vte, 1800(1)-1890(2)hp, 16.5kts, 40p; 2x1-105/45(1), 3x1-88/45(2), 30m, MS
			2	M50	1916		
	M57	32	3	M60	1918		535(3,4)-539(5)-553(6,8-11,) -548(13,16-20)-564(14,22,23) -560(15,24,32,)-550(25-31,33,34) -590(21)t, 59.3(3-5,7-12,14,21-23)-58.2(6)-59.6(13,15-20,24-28,32-34)-59.5(29-30)x7.3(3,4,6,7,12,13,15-20,24-34)-7.4(5,8-11,14,21-23)x2.2(1-13,15-21,24-34)-2.3(14,22,23)m, 2b,2vte, 1750(3,4)-1850(5,8-11,15,21,24-28,32-34) -1790(6)-1870(7,12) -1840(13,16-20)-1600(29-31)hp, 16(1-6,8-11,13-28,32-34)-16.5(7,12)-15(29-31)kts, 40p; 2x1-105/45(3-5,8,9,13-34), 2x1-88/45(6,11,12), 3x1-88/45(7,10), 30m, MS
			4	M61	1918		
			5	M66	1917		
			6	M72	1918		
			7	M75	1917		
			8	M81	1919		
			9	M82	1919		
			10	M84	1917		
			11	M85	1918		
			12	M89	1918		
			13	M98	1918		
			14	M102	1918		
			15	M104	1918		
			16	M107	1918		
			17	M108	1918		
			18	M109	1918		
			19	M110	1918		
			20	M111	1918		
			21	M113	1920		
			22	M115	1918		
			23	M117	1919		
			24	M122	1919		
			25	M126	1919		
			26	M129	1919		
			27	M130	1919		
			28	M132	1919		
			29	M133	1919		
			30	M134	1920		

31	M136	1919
32	M145	1919
33	M146	1919
34	M157	1919

© Ivan Gogin, 2011-14



[home](#)

[World navies yesterday](#)

[1925](#)

## Greece 01 January 1925



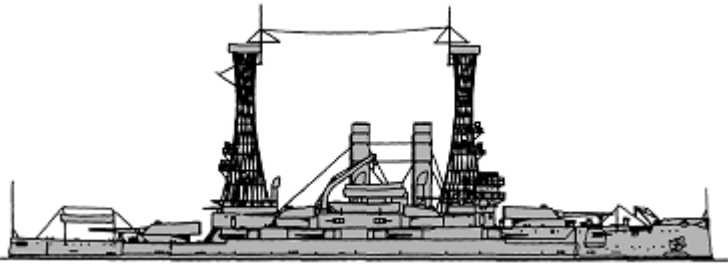

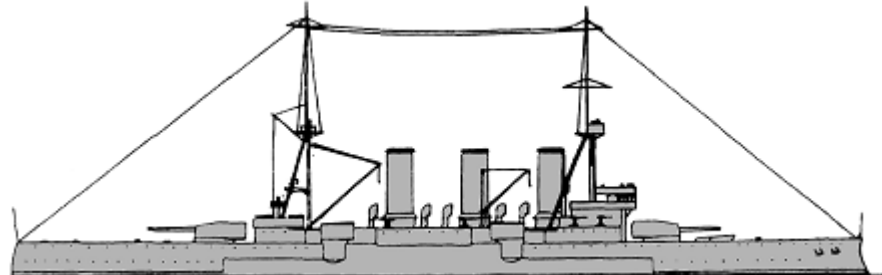
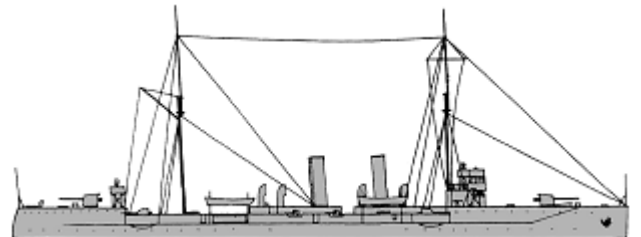

### CAPITAL SHIPS

		1	Kilkis	1908		14465t, 116.4x23.5x7.5m, 8b,2vte, 10000hp, 17kts, 744p; 229belt, 37deck, 305turrets, 229CT; 2x2-305/45, 4x2-203/45, 8x1-178/45, 12x1-76/50, 6x1-47/50, 2x1-37/50, 2-533TT
BB	Kilkis	2	Limnos	1908		

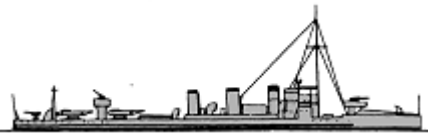
### CRUISERS

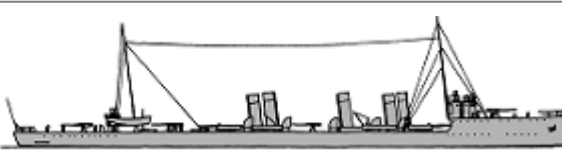
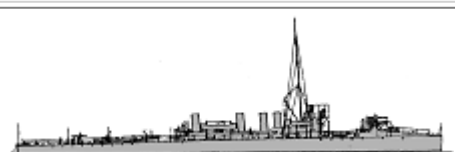
CA	Averof	1	1	Averof	1911		10200t, 140.8x21.0x7.5m, 22b,2vte, 19000hp, 22.5kts, 670p; 200belt, 50deck, 140turrets, 180CT; 2x2-234/45, 4x2-190/45, 17x1-76/40, 4x1-47/40, 3-450TT
	Navarchos Miaoulis	1	1	Navarchos Miaoulis (TS)	1879	No picture	1820t, 75.0ppx11.0x4.4m, 1vte, 2400hp, 13.5kts, 180p; 3x1-170/25, 1x1-170/20, 6x1-37/23, 3-356TT
CL	Elli	1	2	Elli	1913		2750t, 98.1x11.9x4.3m, 3b,3t, 7500hp, 20kts, 232p; 51slopes, 25deck, 50CT; 2x1-152/50, 4x1-102/50, 2x1-76/40, 1x1-57/40, 8x1-47/40, 2x1-37/37, 2x1-450TT

### TORPEDO SHIPS

DD	Niki	3	1	Niki	1906		350t, 67.0x6.6x2.7m, 4b,2vte, 6800hp, 30kts, 58p; 2x1-76/40, 4x1-57/40, 2x1-450TT
			2	Aspis	1906		
			3	Velos	1907		
	Thyella	3	4	Thyella	1907		380t, 67.1x6.2x1.8m, 4b,2vte, 6000hp, 30kts, 70p; 2x1-76/40, 4x1-57/40, 2x1-450TT
			5	Lonchi	1907		
			6	Sfendoni	1907		
	Aetos	4	7	Aetos	1912		1175t, 89.3x8.5x2.6m, 5b,2t, 22000hp, 32kts, 90p; 4x1-102/50, 1x1-57/40(7-9), 4x1-533TT
			8	Ierax	1912		
			9	Leon	1912		
			10	Panthir	1912		
Smyrni	1	11	Smyrni	1906		420t, 68.4x6.3x1.9m, 4b,2vte, 6000hp, 28.4kts, 65p; 6x1-76/40, 2x1-450TT	
TB	Aigli	6	1	Aigli	1912		125t, 45.0x5.0x1.2m, 2b,1vte, 2400hp, 24kts, 20p; 2x1-57/45, 3x1-450TT
			2	Alkyoni	1914		
			3	Arethousa	1913		
			4	Doris	1913		
			5	Dafni	1913		
			6	Thetis	1913		
	Panormos	3	7	Panormos	1916		330t, 58.8x5.8x1.5m, 2b,2t, 5000hp, 28kts, 38p; 2x1-66/30, 2x2-450TT, 12m
			8	Proussa	1916		
			9	Pergamos	1916		
	Kyzikos	3	10	Kyzikos	1915		330t, 60.5x5.6x1.6m, 2b,2t, 5000hp, 28.5kts, 38p; 2x1-66/30, 2x2-450TT, 12m
			11	Kios	1915		
			12	Kidoniai	1916		

## OTHER FIGHTING SHIPS

PG	Afroessa	1	1	Plixavra	1857	No picture	220t, 10kts; 6guns
	Hydra	1	2	Amvrakia	1881	No picture	470t, 39.0ppx7.9x2.2m, 2vc, 690hp, 12kts, 64p; 1x1-260/30, 1-356TT
	Achelaos	2	3	Achelaos	1884		400(3)-420(4)t, 42.0(3)-41.0(4) x7.4(3)-7.6(4) x3.5(3)-4.0(4)m, vc, 400hp, 9.8(3)-10.5(4)kts; 2x1-96/26, 2x1-37/35(3), 3x1-37/35(4)
			4	Eurotas	1884		
	Kichli	2	5, 6	Kichli, Kissa	1884	No picture	86t, 24.2x4.9x2.1m, 1vc, 162hp, 10kts

## COASTAL FORCES

YP	B1	1	1	B3	1918		37t, 24.4x3.7x1.2m, 2pe, 440hp, 19kts, 8p; 1x1-47/50, 2DCR, MS
----	----	---	---	----	------	---	--

## MINE WARFARE SHIPS





AML	-	2	1	Korgialenios	1916		380t; 50m
			2	Tenedos	1906		450t; 40m
AMS	-	2	1	Y1	1910		140t
			2	Y3	1910		140t

© Ivan Gogin, 2011-14

[home](#)[World navies yesterday](#)[1925](#)

# Hungary 01 January 1925

## RIVER BOATS



PGR	Compo	1	Szeged	1916		133t, 44.0x6.0x1.0m, 2b,2gt, 1200hp, 15kts, 40p; 8belt, 6deck, 10turrets, 10CT; 2x2-66/30	
		2	Kecskemét	1916			
	Komarom	1	3	Debreczen	1918		160t, 45.5x6.0x1.0m, 2b,2gt, 1400hp, 16kts, 42p; 10belt, 6deck, 22turrets, 10CT; 2x1-84/33
YPAR	Hüszar	3	1-3	Honved, Hüszar, Tüzér	1916		18(1)-15(2,3)t, 15.2(1)-16.0(2,3)x3.1(1)-2.8(2,3)x0.7(1)-0.6(2,3)m, 2pe, 100hp, 11.5kts, 9p; 7belt, 5deck, 7turret, 7CT
	Siofok	1	4	Siofok	1916		60t, 36.0x4.6x0.9m, 2b,2vte, 800hp, 12kts, 27p; 5belt, 4deck, 5turret, 5CT; 1x1-66/30

© Ivan Gogin, 2011-15

[home](#)[World navies yesterday](#)[1925](#)

# INDIA 01 January 1925

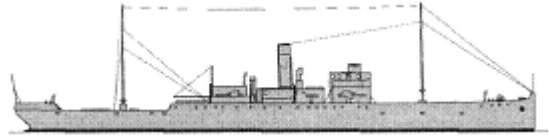
## ESCORTS

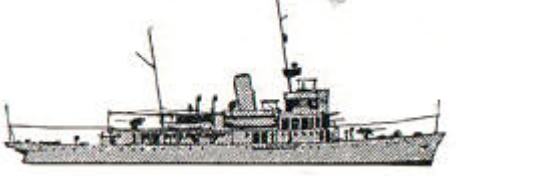
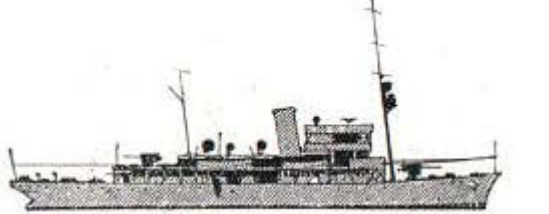
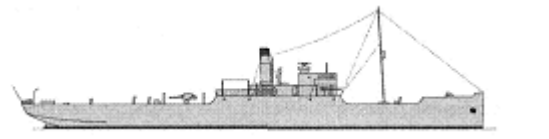
SL	Aubrietia	1	1	Cornwallis	1917		1450t, 81.7x10.2x3.4m, 2b, 1vte, 2500hp, 17.5kts, 92p; 2x1-102/40, 1x1-47/50, 2DCT, 1DCR
	Anchusa	1	2	Elphinstone	1917		1493t, 80.0x10.7x3.5m, 2b, 1vte, 2500hp, 17.5kts, 119p; 2x1-102/40, 2x1-76/40, 2DCT, 2DCR
	Lawrence	1	3	Lawrence	1919		1412t, 69.6x10.4x3.6m, 2b, 2t, 1900hp, 15kts, 119p; 2x1-102/40
	Clive	1	4	Clive	1920		2021t, 80.0x11.7x4.3m, 2b, 2t, 2000hp, 14.5kts, 123p; 2x1-102/40
FS	PC-boat	2	1 2	Baluchi Pathan	1917 1918		780t, 75.3x7.8(1)-8.2(2)x2.4m, 2b, 2t, 3500hp, 20kts, 55p; 1x1-102/40, 2x1-76/40, 2x1-356TT, 2DCR





[home](#)

[World navies yesterday](#)

[1925](#)

## Ireland 01 January 1925

### ESCORTS

APC	-	1	1	Muirchú	1908	323brt; 1x1-76/40
-----	---	---	---	---------	------	-------------------



© Ivan Gogin, 2011-15

[home](#)

[World navies yesterday](#)

[1925](#)

# ITALY 01 January 1925

## CAPITAL SHIPS

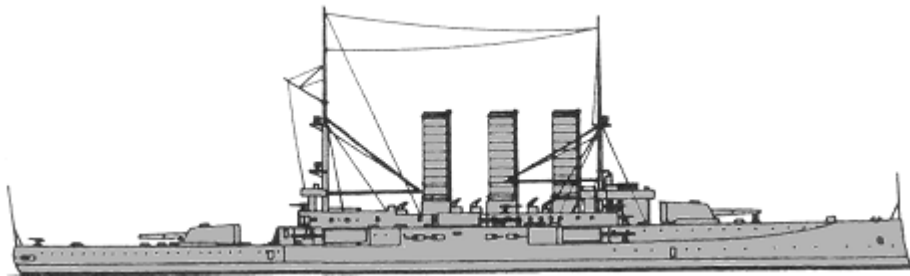
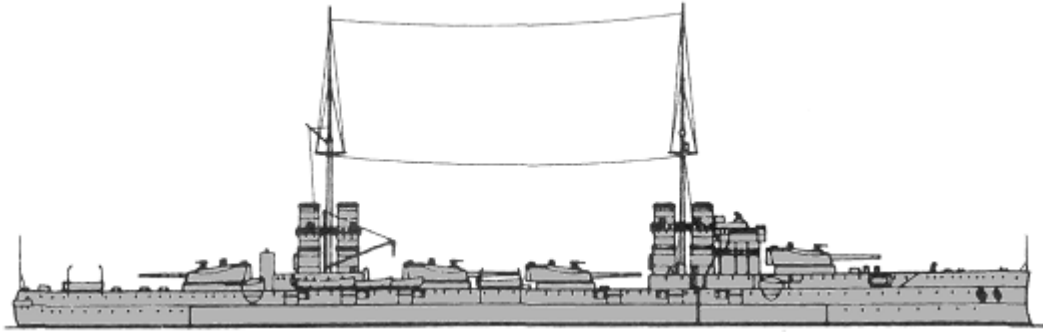
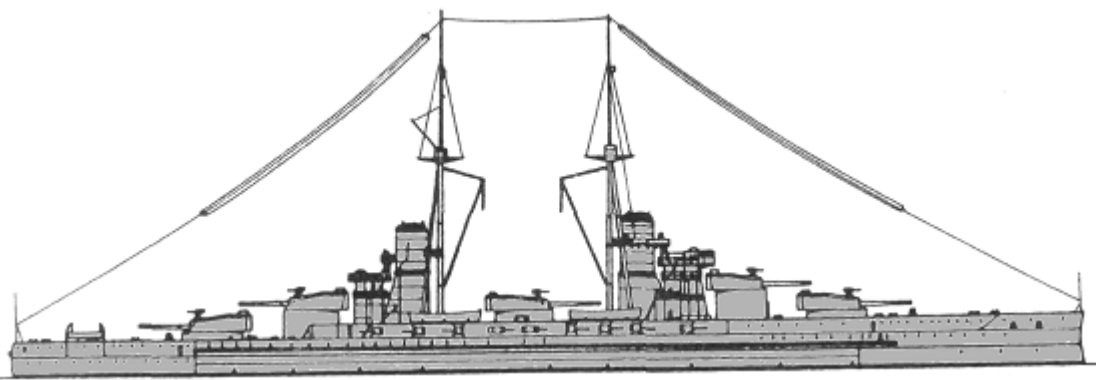
	Regina Elena	1	Roma	1908		13950(1)-14112(2)t, 144.6x22.4x7.9(1)-8.0(2)m, 18b(1)-22b(2),2vte, 21968(1)-19618(2)hp, 21.4(1)-22.2(2)kts, 764p; 250belt, 38/50deck, 250turrets, 250CT; 2x1-305/40, 6x2-203/45, 24x1-76/40, 2-450TT
		2	Napoli	1908		
	Dante Alighieri	1	Dante Alighieri	1913		21800t, 168.1x26.6x8.8m, 23b,4gt, 32190hp, 22.8kts, 981p; 250belt, 50deck, 250turrets, 280CT; 4x3-305/46, (4x2+12x1)-120/50, 12x1-76/50, 2x1-40/39, 3-450TT
BB	Giulio Cesare	4	Giulio Cesare	1914		24801(4)-24250(5)t, 176.1x28.0x8.7m, 24b(4)-20b(5),4gt, 30700(4)-31278(5)hp, 21.6(4)-22.2(5)kts, 1235p; 250belt, 30+30+24/40deck, 280turrets, 280CT; (3x3+2x2)-305/46, 18x1-120/50, 19x1-76/50(4), 20x1-76/50(5), 3-450TT
		5	Conte di Cavour	1915		
		6	Caio Duilio	1915		

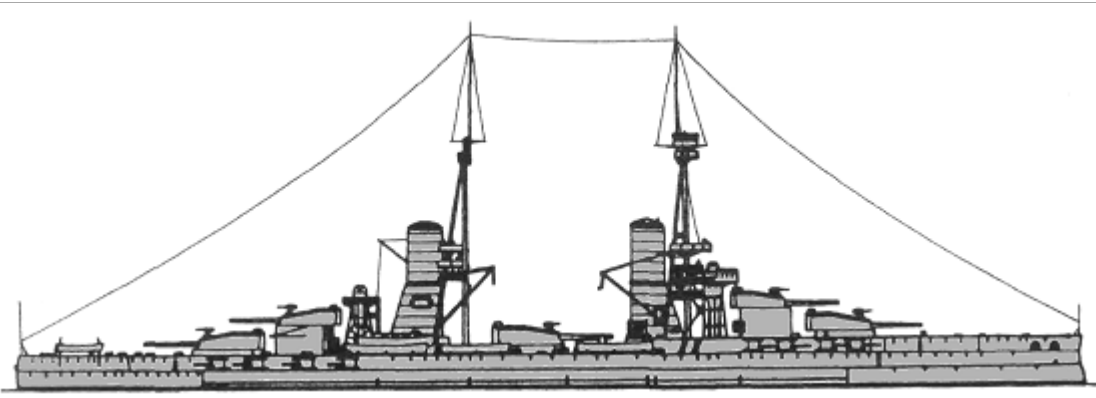

						
Duilio	2	7	Andrea Doria	1916		24715(6)-24279(7)t, 176.1x28.0x8.9m, 20b,4gt, 30000hp, 21kts, 1232p; 250belt, 44+30+24/40deck, 280turrets, 280CT; (3x3+2x2)-305/46, 16x1-152/45, 19x1-76/50, 3-450TT

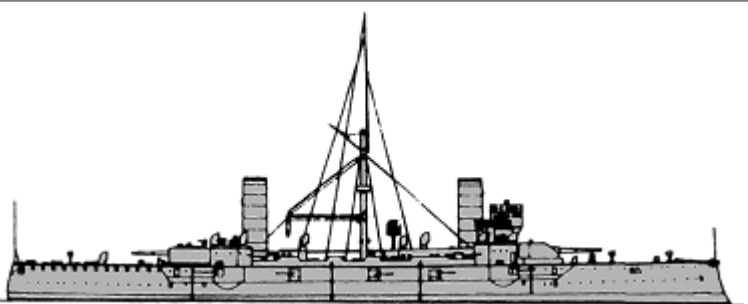
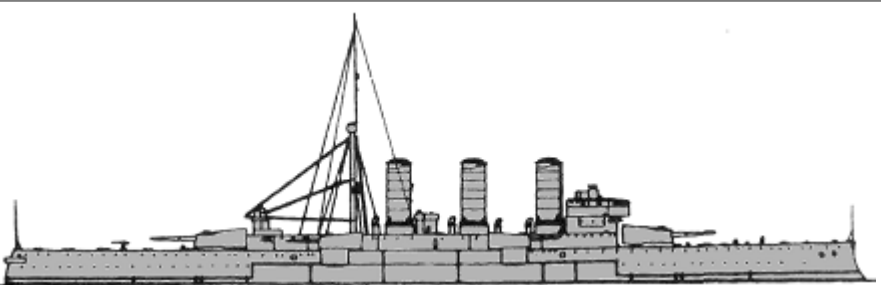
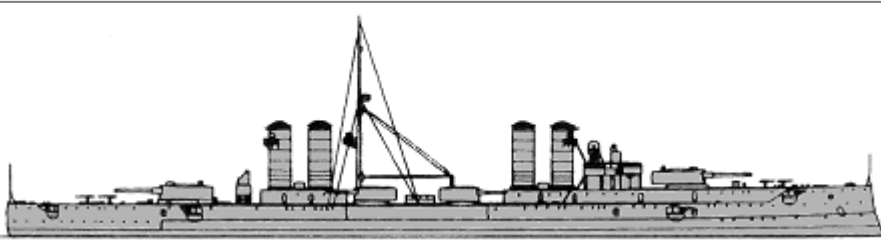
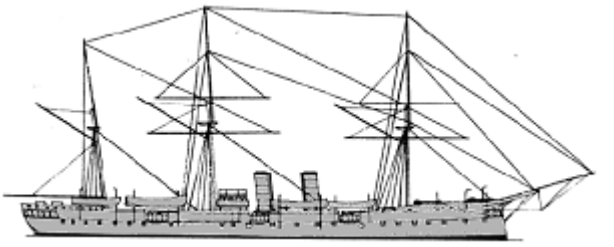

## CRUISERS

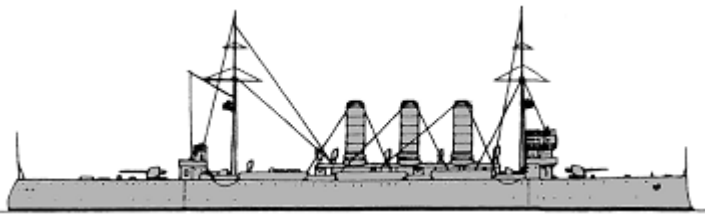
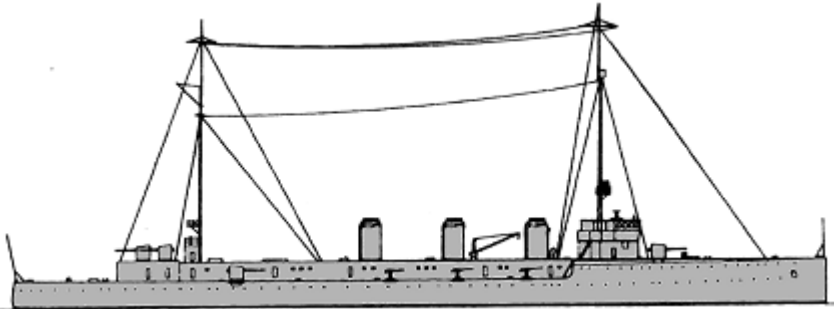
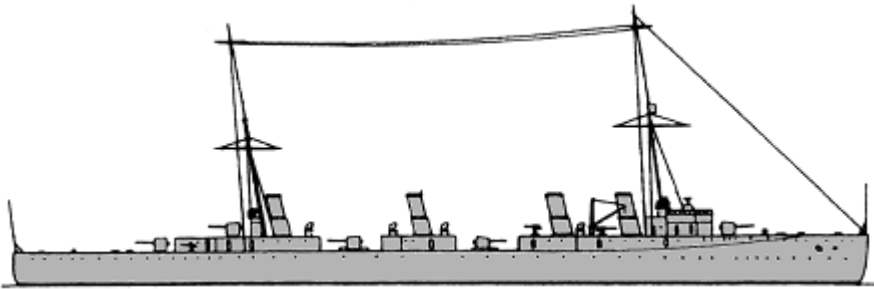
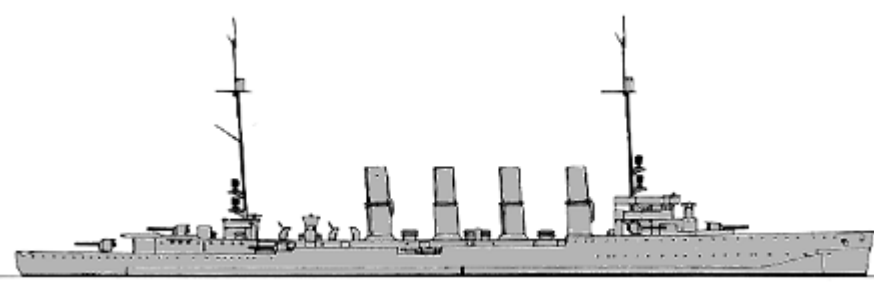
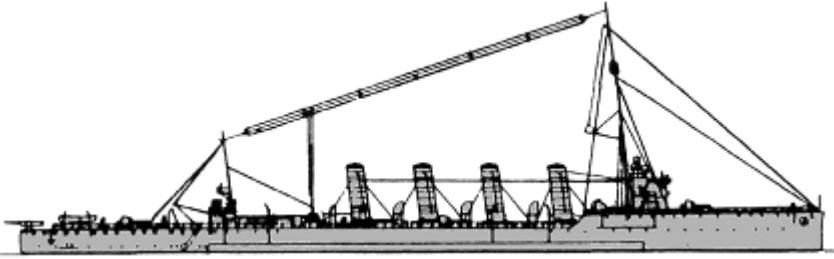
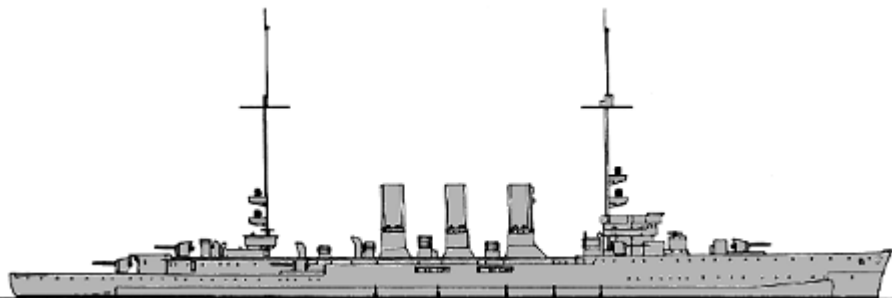

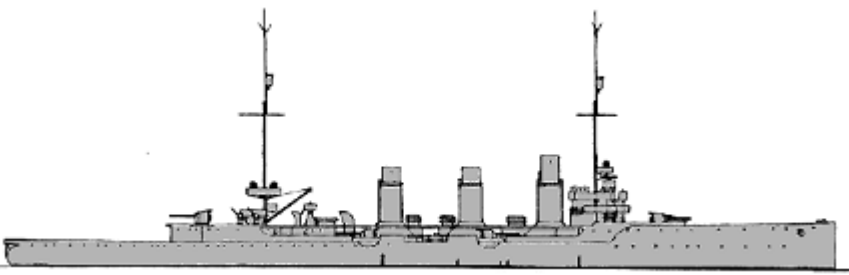

CA	Garibaldi	1	1	Francesco Ferruccio (TS)	1905		7972t, 111.8x18.3x7.1m, 24b,2vte, 13500hp, 19.3kts, 559p; 150belt, 38deck, 150turrets, 150CT; 1x1-254/40, 1x2-203/45, 14x1-152/40, 10x1-76/40, 4-450TT
	Pisa	1	2	Pisa	1909		10600t, 140.5x21.0x7.1m, 22b,2vte, 20000hp, 23kts, 687p; 200belt, 50/130deck, 160turrets, 180CT; 2x2-254/45, 4x2-190/45, 20x1-76/40, 3-450TT
	San Giorgio	2	4	San Marco	1911		11300(3)-11900(4)t, 140.8x21.0x7.3(3)-7.8(4)m, 14b, 2vte(3)-4t(4), 19500(3)-23000(4)hp, 23.2(3)-23.8(4)kts, 705p; 200belt, 50deck, 200turrets, 250CT; 2x2-254/45, 4x2-190/45, 16x1-76/40, 3-450TT
	Vespucci	1	1	Amerigo Vespucci (TS)	1884		2751t, 78.0ppx12.8x5.5m, 8b,1hre, 3000hp, 13kts, 268p; 4x1-76/40
							4466t, 111.8x14.5x5.5m, 16b,2vte, 11530hp, 22.9kts, 314p; 100deck, 76shields, 100CT;

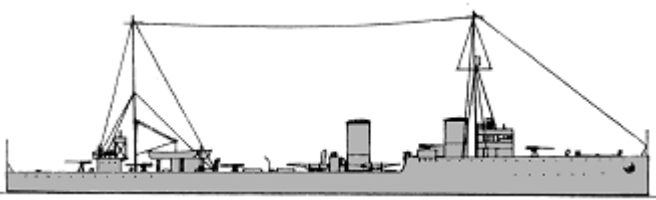
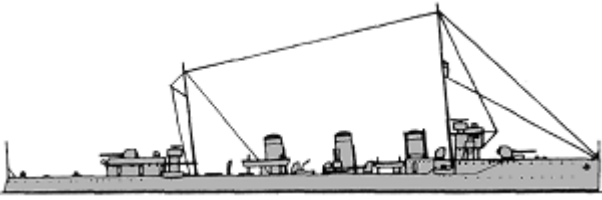
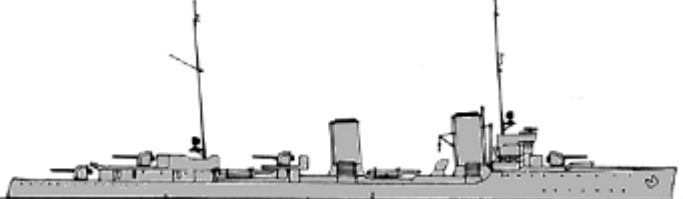
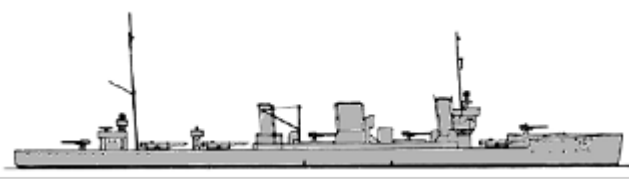
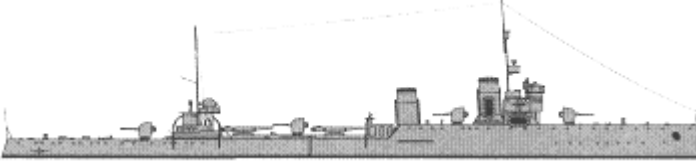



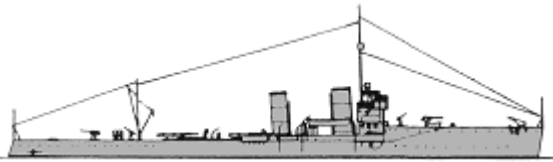

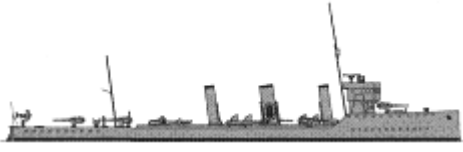
CL	Libia	1 2	Libia	1913		2x1-152/50, 8x1-120/45, 3x1-76/40, 2-450TT
	Quarto	1 3	Quarto	1913		3442t, 131.6x12.8x4.1m, 10b,4t, 25000hp, 28kts, 247p; 40deck, 100CT; 6x1-120/50, 6x1-76/50, 2-450TT, 200m
	Nino Bixio	4	Nino Bixio	1914		4141t, 140.3x13.0x4.1m, 14b,3t, 22500hp, 26.8(4)-27.5(5)kts, 296p; 40deck, 100CT; 6x1-120/50, 6x1-76/50, 2x1-40/39, 2-450TT, 200m
		5	Marsala	1914		
	Taranto	1 6	Taranto	1912		5281t, 138.7x13.5x5.1m, 16b,2t, 27000hp, 27.5kts, 486p; 60belt, 40/60deck, 50shields, 100CT; 7x1-150/43, 2x1-76/40, (2+2x1)-500TT, 120m
	Brindisi	7	Brindisi	1914		4375(7)-4327(8)t, 130.6x12.8x5.3m, 16b,2t, 25600hp, 27kts, 368p; 60belt, 20deck, 40shields, 50CT; 9x1-100/47, 1x1-37/43, 2x2-533TT, 120m
		8	Venezia	1914		
Ancona	1 9	Ancona	1914		6382t, 142.7x13.8x6.1m, 12b,2t, 26000hp, 27kts, 385p; 60belt, 40/60deck, 50shields, 100CT; 7x1-150/43, 3x1-76/40, 4x1-500TT, 120m	

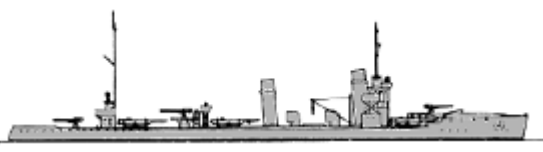
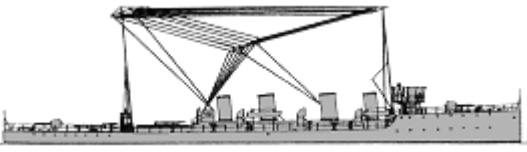
							5305t, 135.3x13.6x6.0m, 10b,2t, 28000hp, 28kts, 440p; 80deck, 50shields, 75CT; 8x1-150/43, 3x1-76/40, 2x1-500TT, 120m
	Bari	1	10	Bari	1914		

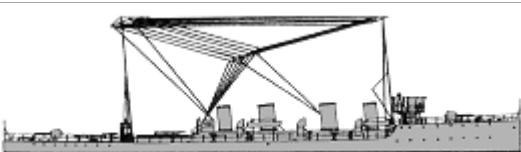
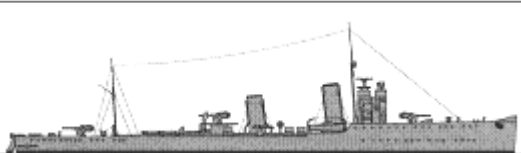
## TORPEDO SHIPS

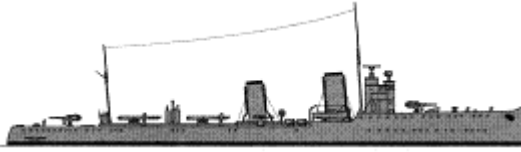
DL	Mirabello	2	1	Carlo Mirabello	1916		1972t, 103.4x9.7x3.3m, 4b,2t, 44000hp, 35kts, 169p; 8x1-102/45, 2x1-40/39, 2x2-450TT, 100m(1), 120m(2)
			2	Augusto Riboty	1917		
	Aquila	2	3	Aquila	1917		1733(3)-1760(4)t, 94.7x9.5x3.6m, 5b,2t, 40000hp, 146p; (2x2+1x1)-120/45, 2x1-76/40, 2x2-450TT, 44m(3), 38m(4)
			4	Falco	1920		
	Pemuda	1	5	Pemuda	1918		2555t, 107.5x10.4x3.8m, 4b,2t, 45000hp, 34.5kts, 162p; 4x1-150/42, 2x1-40/39, 2x2-600TT, 40m
	Rossarol	1	6	Cesare Rossarol	1915		1756t, 98.0x9.4x3.9m, 4b,2t, 40000hp, 36.5kts, 114p; (1x2+1x1)-120/45, 2x1-76/40, 2x2-500TT, 29m
	Leone	3	7	Leone	1924		2289t, 113.4x10.3x3.2m, 4b,2t, 42000hp, 34kts, 204p; 4x2-120/45, 2x1-76/40, 2x3-450TT, 60m
			8	Pantera	1924		
			9	Tigre	1924		
	Indomito	4	1	Indomito	1913		900t, 73.0x7.3x2.4m, 4b,2t, 16000hp, 28kts, 79p; 5x1-102/35, 1x1-40/39, 2x2-450TT, 10m
2			Impavido	1913			
3			Insidioso	1914			
4			Irrequeto	1913			
Ardito	2	5	Ardito	1913		900t, 73.0x7.3x2.4m, 4b,2t, 16000hp, 28kts, 69p; 5x1-102/35, 1x1-40/39, 2x2-450TT, 10m	
		6	Ardente	1914			

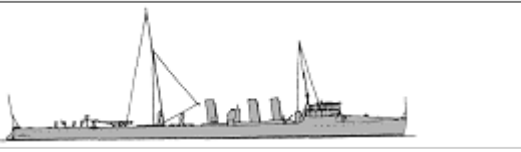
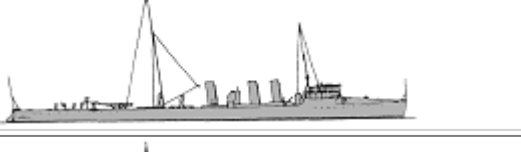

						
Poerio	2	7	Alessandro Poerio	1915		1216t, 85.0x8.0x2.8m, 3b,2t, 20000hp, 31.5kts, 129p; 5x1-102/45(7), 6x1-102/45(8), 2x1-40/39, 2x2-450TT, 42m
		8	Guglielmo Pepe	1915		
Pilo	8	9	Rosolino Pilo	1915		912t, 73.0x7.3x2.3m, 4b,2t, 16000(9-12,14,16)-14800(13,15)hp, 30(9-12,14,16)-29(13,15)kts, 79p; 5x1-102/35, 2x1-40/39, 4x1-450TT, 10m
		10	Giuseppe Cesare Abba	1915		
		11	Giuseppe Dezza	1916		
		12	Giuseppe Missori	1916		
		13	Antonio Mosto	1915		
		14	Ippolito Nievo	1915		
		15	Fratelli Cairoli	1915		
16	Simone Schiaffino	1915				
Sirtori	4	17	Giuseppe Sirtori	1916		850t, 73.5x7.3x2.8m, 4b,2t, 15500hp, 30kts, 85p; 6x1-102/45, 2x1-40/39, 2x2-450TT, 10m
		18	Giovanni Acerbi	1917		
		19	Vincenzo Giordano Orsini	1917		
		20	Francesco Stocco	1917		
Audace	1	21	Audace	1917		1170t, 87.5x8.3x2.5m, 3b,2t, 22000hp, 30kts, 118p; 7x1-102/35, 2x1-40/39, 2x2-450TT
DD La Masa	7	22	Giuseppe La Masa	1919		851t, 73.5x7.3x2.8m, 4b,2t, 15500hp, 30kts, 78p; 4x1-102/45, 2x1-76/40, 2x2-450TT, 10m
		23	Angelo Bassini	1918		
		24	Enrico Cosenz	1919		
		25	Giacinto Carini	1917		
		26	Nicola Fabrizzi	1918		
		27	Giuseppe La Farina	1919		
		28	Giacomo Medici	1918		
Ardimentoso	1	29	Ardimentoso	1916		1170t, 83.1x8.4x3.6m, 3b,2t/1t(2), 24000hp, 34kts, 85p; 3x1-105/42, (2x2+2x1)-500TT, 24m
Fasana	2	30	Muggia	1913		1000t, 83.5x7.8x2.4m, 6b,2t, 20640hp, 32.6kts, 105p; 2x1-100/47, 6x1-66/47, 2x2-450TT
		31	Pola	1914		

Grado	3	32	Cortelazzo	1917		1045t, 85.4x7.8x2.4m, 6b,2t, 22360hp, 32.6kts, 114p; 2x1-100/47, 6x1-66/47, 2x2-450TT
		33	Grado	1917		
		34	Monfalcone	1918		
Palestro	4	35	Palestro	1921		1076t, 81.9x8.0x2.7m, 4b,2t, 18000hp, 32kts, 118p; 4x1-102/45, 2x1-76/40, 2x2-450TT, 38m
		36	Confienza	1923		
		37	San Martino	1922		
		38	Solferino	1921		
Generali	6	39	Generale Antonio Cantore	1921		870t, 73.5x7.3x2.7m, 4b,2t, 15500hp, 30kts, 118p; 3x1-102/45, 2x1-76/40, 2x2-450TT, 2DCT
		40	Generale Antonio Cascino	1922		
		41	Generale Antonio Chinotto	1921		
		42	Generale Carlo Montanari	1922		
		43	Generale Achille Papa	1922		
		44	Generale Marcello Prestinari	1922		
Curtatone	4	45	Calatafimi	1924		1214t, 84.7x8.0x2.9m, 4b,2t, 22000hp, 32kts, 117p; 2x2-102/45, 2x1-76/30, 2x3-450TT, 16m
		46	Castelfidardo	1924		
		47	Curtatone	1923		
		48	Monzambano	1924		
Cigno	4	1	Calipso	1909		208(1)-217(2-4)t, 50.3x5.3x1.7m, 2b,2vte, 2900hp, 25kts, 35(1)-38(2-4)p; 2x1-76/40, 1x1-13.2, 4x1-450TT or (1x2+2x1)-450TT
		2	Cassiopea	1906		
		3	Climene	1909		
		4	Clio	1907		
Soldati-1	2	5	Corazziere	1910		412t, 65.0x6.1x2.1m, 3b,2vte, 6000hp, 28.5kts, 55p; 4x1-76/40, 3x1-450TT, 10m
		6	Granatiere	1907		
Soldati-2	3	7	Alpino	1910		424t, 65.0x6.1x2.1m, 3b,2vte, 6000hp, 28.5kts, 50p; 4x1-76/40, 3x1-450TT, 10m
		8	Fuciliere	1910		
		9	Pontiere	1910		
Ascaro	1	10	Ascaro	1913		414t, 65.0x6.1x2.1m, 3b,2vte, 6000hp, 28.5kts, 55p; 4x1-76/40, 3x1-450TT, 10m
		11	1PN	1911		
		12	2PN	1911		
		13	3PN	1911		
		14	4PN	1911		



TB	1PN	33	15	6PN	1912			
			16	7PN	1912			
			17	8PN	1912			
			18	9PN	1912			
			19	10PN	1912			
			20	11PN	1913			
			21	12PN	1913			
			22	13OS	1912			
			23	14OS	1912			
			24	15OS	1912			
			25	16OS	1912			
			26	18OS	1912			
			27	19OS	1912			
			28	20OS	1913			
			29	21OS	1913			
			30	22OS	1912			
			31	23OS	1913			
			32	24OS	1913			
			33	25AS	1912			
			34	26AS	1913			
			35	27AS	1913			
			36	28AS	1913			
			37	29AS	1913			
			38	30AS	1913			
			39	33PN	1913			
			40	34PN	1913			
			41	35PN	1913			
			42	37PN	1913			
			43	38PN	1913			
						44	40PN	1916
						45	41PN	1916
						46	42PN	1916
						47	43PN	1916
						48	44PN	1916
						49	45PN	1916
						50	46OS	1916
						51	47OS	1916
						52	48OS	1916
						53	49OS	1916
						54	50OS	1916
						55	51OS	1916







143t, 42.5x4.6x1.5m, 2b,2vte, 3200hp, 27kts, 30p; 1x1-76/40, 1x1-76/30, 2x1-450TT, 10m(11-14,16,17,34-38)

40PN	30	56	52AS	1916		168t, 42.5x4.6x1.6m, 2b,2vte, 2700hp, 27kts, 30p; 2x1-76/30, 1x1-37/43(50-55,56,58,62-64), 1x2-450TT, 10m
		57	53AS	1916		
		58	54AS	1916		
		59	55AS	1916		
		60	56AS	1916		
		61	57AS	1916		
		62	58OL	1916		
		63	59OL	1916		
		64	60OL	1916		
		65	61OL	1916		
		66	62OL	1916		
		67	63OL	1916		
		68	64PN	1917		
		69	65PN	1918		
70OLT	2	74	74OLT	1918		195t, 45.7x4.6x1.8m, 2b,2t, 3500hp, 27kts, 31p; 2x1-76/30, 1x2-450TT, 7m
		75	75OLT	1918		

## SUBMARINES

Argonauta	1	1	Argonauta	1915		255/306t, 45.2x4.2x3.1m, 2d/em, 700/450hp, 13.5/8.8kts, 24p, 40m; 1x1-76/30, 2-450TT
F	17	2	F1	1916		262/319t, 45.6x4.2x3.1m, 2d/em, 670/500hp, 12.5/8.2kts, 26p, 40m; 1x1-76/30, 2-450TT
		3	F2	1916		
		4	F5	1916		
		5	F6	1917		
		6	F7	1917		
		7	F9	1916		
		8	F10	1916		
		9	F12	1917		
		10	F13	1917		
		11	F14	1917		
		12	F15	1917		
13	F16	1917				
14	F17	1917				
15	F18	1917				
16	F19	1918				

SS	H	7	17	F20	1918		364/475t, 45.8x4.7x3.8m, 2d/em, 480/620hp, 12/11kts, 22p, 50m; 1x1-76/30, 4-450TT
			18	F21	1918		
			19	H1	1916		
			20	H2	1916		
			21	H3	1917		
			22	H4	1917		
			23	H6	1917		
			24	H7	1917		
	25	H8	1918				
	Micca	6	26	Pietro Micca	1918		842/1244t, 63.2x6.2x4.3m, 2d/em, 2900/1800hp, 11/10.9kts, 40p, 50m; 1x1-76/40, 1x1-76/30, 6-450TT
			27	Angelo Emo	1919		
			28	Luigi Galvani	1918		
			29	Lorenzo Marcello	1919		
			30	Lazzaro Mocenigo	1920		
	Provana	4	32	Andrea Provana	1918		762/924t, 67.0x5.9x3.8m, 2d/em, 2600/1400hp, 16/9.8kts, 40p, 50m; 2x1-76/40, 6-450TT
			33	Agostino Barbarigo	1918		
			34	Giacomo Nani	1919		
			35	Sebastiano Veniero	1919		
	N	6	36	N1	1918		277/363t, 45.8x4.3x3.2m, 2d/em, 650(36-39)-820(40,41)/450hp, 12.5(36-39)-13.5(40,41)/7.9kts, 23p, 40m; 1x1-76/30, 2-450TT
			37	N2	1918		
			38	N3	1918		
			39	N4	1919		
			40	N5	1919		
			41	N6	1919		
	X2	2	42	X2	1918		403/468t, 42.6x5.5x3.2m, 2d/em, 650/325hp, 8.2/6.3kts, 25p, 40m; 1x1-76/30, 2-450TT, 18m
43			X3	1918			

## ESCORTS

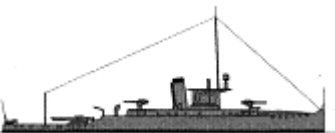
PC	Bafile	5	1	Andrea Bafile	1922		284t, 52.1x5.7x1.8m, 2b,2vte, 2400hp, 24kts, 53p; 2x1-102/35, 1x2-450TT, 12m
			2	Carlo del Greco	1922		
			3	Tolosso Farinati	1922		
			4	Ernesto Giovannini	1922		
			5	Alessandro Vitturi	1922		
			1	Berenice	1912		425t; 2x1-76/40
			2	Maggiore Toselli	1912		370t
			3	Cirene	1912		500t; 2x1-76/40
			4	Porto Corsini	1912		380t; 2x1-76/40
			5	Rimini	1912		420t; 2x1-76/40





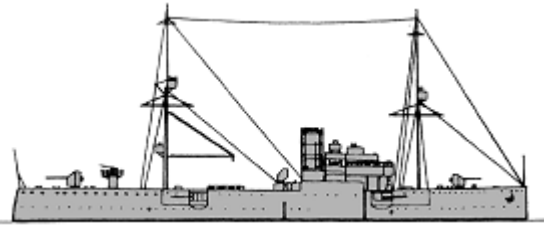
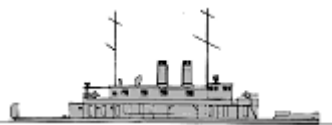

APC	-	24	6	Alula	1912		430t; 1x1-76/40			
			7	Mario Blanco	1911		385t; 2x1-76/40			
			8	Gallipoli	1911		400t; 2x1-76/40			
			9	Otranto	1911		385t; 2x1-76/40			
			10	Augusta	1911		390t; 2x1-76/30			
			11	Valoroso	1913		420t; 2x1-76/40			
			12	Balena	1911		286t; 1x1-76/40			
			13	Basiluzzo	1915		110t			
			14	Burrasca	1912		280t; 1x1-76/40			
			15	Gaeta	1916		250t; 1x1-76/40			
			16	Lampedusa	1915		166t; 1x1-76/40			
			17	Lilibeo	1915		124t			
			18	Liscanera	1916		222t; 1x1-76/40			
			19	Porto d'Anzio	1914		166t; 1x1-76/40			
			20	Portofino	1915		270t; 1x1-76/40			
			21	Scolta	1913		424t; 2x1-76/40			
			22	Talamone	1916		190t; 1x1-76/40			
			23	Terracina	1916		230t; 1x1-76/40			
			24	Vigilante	1906		316t; 1x1-76/40			
			AY	-	4	1	Giuliana	1893		1050t, 76.2x8.5x3.9m, 1vte, 11.9kts; 2x1-76/40
						2	Archimede	1892		900t; 4x1-57/43
						3	Capitano Verri	1887		705t; 3x1-102/40
						4	Galileo	1897		850t; 3x1-76/40

## OTHER FIGHTING SHIPS



PG	Sebastiano Caboto	1	1	Sebastiano Caboto	1912	No picture	1050t, 63.4x9.7x3.0m, 2b,2vte, 1200hp, 13.2kts, 107p; 6x1-76/40
	Campania	1	2	Campania	1917		3187t, 83.0x12.7x5.2m, 4b,2vte, 5000hp, 15.7kts, 204p; 25deck, 50CT; 4x1-152/40, 5x1-76/40
APG	-	4	1	Abisso	1912		400t; 2x1-76/40
			2	Generale Arimondi	1910		580t; 1x1-76/40
			3	Boeo	1916		235t; 1x1-76/40
			4	Palmaiola	1902		562t; 1x1-76/40
PR	Carlotto	1	1	Ermanno Carlotto	1921		218t, 48.8x7.5x0.9m, 2b,2vte, 1100hp, 14kts, 44p; 2x1-76/40

## COASTAL FORCES

PT	12t A SVAN	1	1	MAS1	1916		13t, 16.0x2.6x1.0m, 2pe/em, 450/10hp, 23/4kts, 8p; 2-450TT
	12t A-1 SVAN	9	2 - 10	MAS11-13, 15, 16, 18-21	1916 - 1917		16t, 16.0x2.6x1.2m, 2pe(7,9), 2pe/em(2-6,8,10), 450(7,9)-450/10(2-6,8,10)hp, 23(7,9)-23/4(2-6,8,10)kts, 8p; 2-450TT, 1DCR
	12t A-1 SVAN-Ansaldo	1	11	MAS45	1916		12t, 16.0x2.6x1.3m, 2pe, 400hp, 20kts, 8p; 1x1-37/20, 2-356TT
	12t A-2 SVAN	1	12	MAS53	1917		11t, 16.0x2.6x1.2m, 2pe, 450hp, 24kts, 8p; 2-450TT, 1DCR
	12t A-1 Orlando	9	13 - 21	MAS92, 94-98, 100-102	1917 - 1918		13t, 16.2x2.8x1.4m, 2pe(18)-2pe/em(13-17,19-21), 500(18)-500/10(13-17,19-21)hp, 29.5(18)-29.5/4(13-17,19-21)kts, 8p; 2-450TT, 1DCR
	12t mod. A-1 SVAN	3	22 - 24	MAS158-160	1918		12t, 16.0x2.6x1.1m, 2pe, 400(22, 23)-480(24)hp, 23(22,23)-25(24)kts, 8p; 2-450TT
	12t A-1 Baglietto	7	25 - 31	MAS204, 206, 208, 210, 212, 213, 216	1918		14t, 16.0x2.6x1.1m, 2pe/em, 480/10hp, 24/4kts, 7p; 2-450TT, 2DCR
	12t A-2 Orlando	9	32 - 40	MAS218, 219, 222-225, 228-230	1918		13t, 16.4x2.9x1.4m, 2pe/em(32-38)-2pe(39,40), 500/10(32-38)-500(39,40)hp, 26/4(32-38)-26(39,40)kts, 8p; 2-450TT, 1DCR
	12t A-2 SVAN	2	41, 42	MAS325, 326	1918		14t, 16.0x2.9x1.2m, 2pe, 440hp, 23kts, 8p; 2-450TT, 1DCR
	12t mod. A-1 SVAN	2	43, 44	MAS319, 320	1919		14t, 16.0x2.9x1.2m, 2pe, 700hp, 28kts, 8p; 2-450TT, 1DCR
	D-1 Baglietto	4	45 - 48	MAS397-400	1920 - 1924		27t, 21.2x4.2x1.2m, 3pe/2em(3), 1900/10hp, 33/4kts, 12p; 2-450TT, 2DCR
	D-1 SVAN	10	49 - 58	MAS401-410	1923 - 1924		29t, 22.0x4.0x1.2m, 4pe/2em(4), 1600/10hp, 28.6/4kts, 10p; 2-450TT, 2DCR
D-2 SVAN	8	59 - 66	MAS415 - 422	1922 - 1923		21t, 18.0x3.6x1.2m, 3pe/2em(3), 1200/16hp, 26.5/5kts, 10p; 2-450TT, 1DCR	
PG	12t A-1 SVAN-Ansaldo	19	1 - 19	MAS23, 24, 26, 29-31, 33, 34, 36, 38, 40, 41, 44, 46-48, 50-52	1916 - 1917		12t, 16.0x2.6x1.3m, 2pe, 400hp, 20kts, 8p; 1x1-47/43, 4DC
	12t A-2 SVAN	4	20 - 23	MAS54-57	1917		11t, 16.0x2.6x1.2m, 2pe, 400hp, 23kts, 8p; 1x1-47/43, 1DCR
	12t mod. SVAN	2	24, 25	MAS58, 62	1917		12t, 16.0x3.0x1.2m, 3pe(24)-2pe(25), 600(24)-400(25)hp, 25(24)-22.5(25)kts, 8p; 1x1-47/43, 1DCR
	12t mod. A-1 SVAN	33	26 - 58	MAS161-165, 170 - 175, 178 - 181, 183 - 200	1918 - 1919		12t, 16.0x2.6x1.1m, 2pe, 400(29)-480(26-28, 30-58)hp, 23(29)-25(26-28, 30-58)kts, 8p; 1x1-57/43, 1DCR
	MAS318	1	59	MAS318	1917		20t, 17.5x3.2x1.2m, 2pe, 500hp, 20kts, 10p; 1x1-57/43, 2DCR
	19t B-1 SVAN	14	60 - 73	MAS118, 123, 124, 126, 128-133, 136-139	1918		19t, 18.0x3.2x1.2m, 2pe, 500hp, 22kts, 12p; 1x1-76/30, 2DCR
	12t A-mod. SVAN	12	74 - 85	MAS141, 145-151, 154-157	1918 - 1919		12t, 16.0x2.6x1.1m, 2pe, 400(74, 78-85)-480(75-77)hp, 24(74, 78-85)-25(75-77)kts, 8p; 1x1-57/43, 1DCR
	19t B-2 SVAN	10	86 - 95	MAS236-238, 243-245, 247-252	1918 - 1919		19t, 18.0x3.3x1.2m, 2pe, 500hp, 20kts, 12p; 1x1-76/40, 2DCR
	44t C-1 ELCO	12	1 - 12	MAS63, 70, 71, 73, 75, 78, 82-84, 86, 89, 90	1917 - 1918		44t, 24.4x3.7x1.2m, 2pe, 460hp, 16kts, 15p; 1x1-76/40, 2DCR
	44t C-2 ELCO	7	13 - 19	MAS103-105, 107, 110, 113, 264	1918		44t, 24.4x3.7x1.2m, 2pe, 460hp, 16kts, 15p; 1x1-76/30, 2DCR

PS	44t C-3 ELCO	27	20 - 46	MAS256, 258, 260, 262, 263, 265-267, 269-271, 277, 279-284, 289, 291, 292, 294, 297-300, 302	1918		44t, 24.4x3.7x1.2m, 2pe, 460hp, 16kts, 15p; 1x1-76/40, 2DCR
	44t mod. C-1 ELCO	2	47, 48	MAS296, 312	1918 - 1919		45t, 24.4x3.8x1.3m, 2pe, 460hp, 18kts, 15p; 1x1-76/40, 2DCR
	44t mod. C-2 ELCO	16	49 - 64	MAS328-332, 334, 344, 346, 352-357, 372, 374	1918 - 1922		45t, 24.4x3.8x1.3m, 2pe, 460hp, 18kts, 15p; 1x1-76/40, 2DCR
	44t C-4 ELCO	12	65 - 76	MAS377, 381, 383, 385-387, 389-392, 395, 396	1918 - 1919		44t, 24.4x3.7x1.2m, 2pe, 460hp, 16kts, 15p; 1x1-76/40, 2DCR

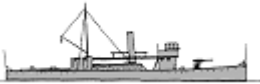
## MINE WARFARE SHIPS

ML	Brondolo	2	1	Brondolo	1909		117t, 38.1x6.3x0.8m, 1b,2vte, 500hp, 13kts, 18p; 1x1-76/40, 20m
			2	Marghera	1909		
MS	RD1	36	1	RD4	1917		196-302t, 34.0-38.0x5.8-7.2x1.9-2.5m, 1b,1vte, 590-1150hp, 10-14kts, 22p; 1x1-76/40, MS
			2	RD6	1917		
			3	RD7	1917		
			4	RD9	1917		
			5	RD11	1917		
			6	RD12	1917		
			7	RD13	1918		
			8	RD16	1917		
			9	RD17	1917		
			10	RD18	1917		
			11	RD20	1917		
			12	RD21	1918		
			13	RD22	1918		
			14	RD23	1918		
			15	RD24	1918		
			16	RD25	1918		
			17	RD26	1918		
			18	RD27	1918		
			19	RD28	1918		
			20	RD29	1919		
			21	RD30	1919		
			22	RD31	1919		
			23	RD32	1919		
			24	RD33	1919		
			25	RD34	1919		
			26	RD35	1919		
			27	RD36	1919		
			28	RD37	1920		

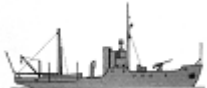
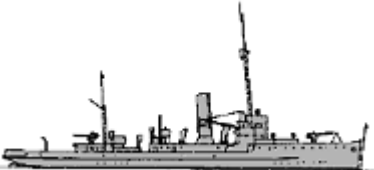
		29	RD38	1921		
		30	RD39	1919		
		31	RD40	1920		
		32	RD41	1920		
		33	RD42	1920		
		34	RD43	1920		
		35	RD44	1920		
		36	RD49	1922		
RD58	3	37	Albona	1920		145t, 31.8x6.5x1.7m, 1b,2vce, 280hp, 11kts, 27p; 1x1-76/40, 34m, MS
		38	Laurana	1920		
		39	Rovigno	1920		
Meteo	2	40	Meteo	1918		560t, 59.6x7.3x2.2m, 2b,2vte, 1850hp, 16kts, 40p; 2x1-105/42, 30m, MS
		41	Abastro	1918		

#### NAVAL AVIATION *(approximately, maximal number of delivered planes signed)*

Seaplanes	F: 144 M.5, 100 M.5 mod., 100 M.7ter <i>(delivery till 1927)</i> , 29 M.7ter AR <i>(delivery till 1927)</i> ; B: ~20 M.18, ~20 M.18 AR <i>(delivery till 1927)</i>
-----------	--



[home](#)

[World navies yesterday](#)

[1925](#)

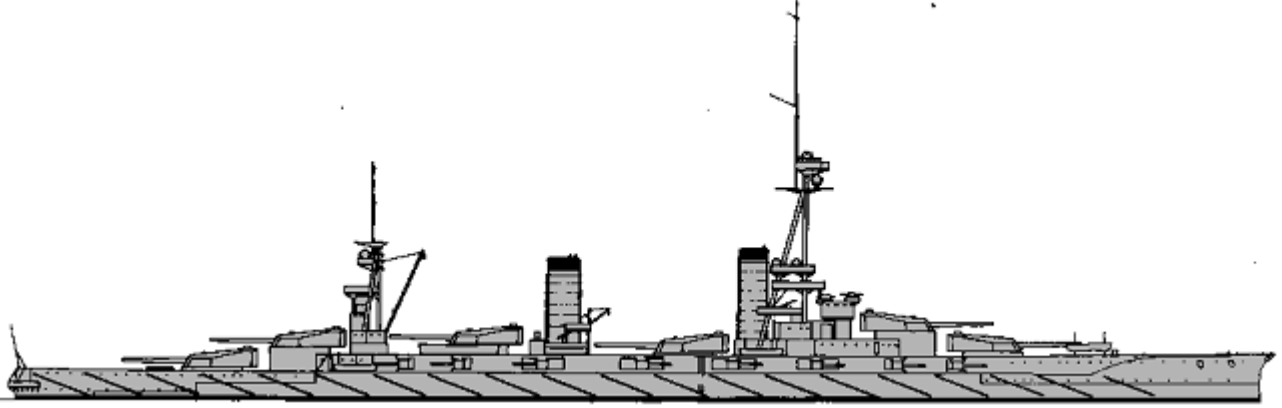
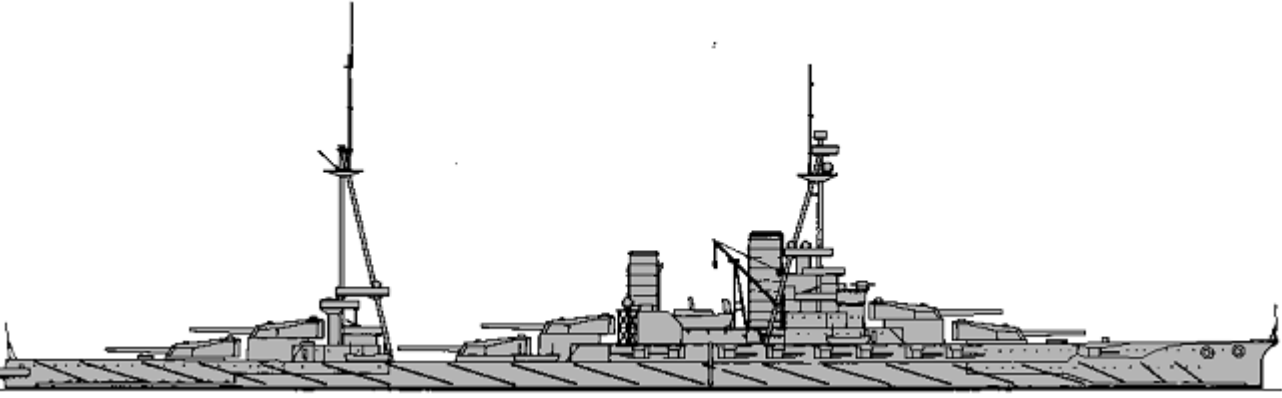

# Japan 01 January 1925

## CAPITAL SHIPS AND MONITORS

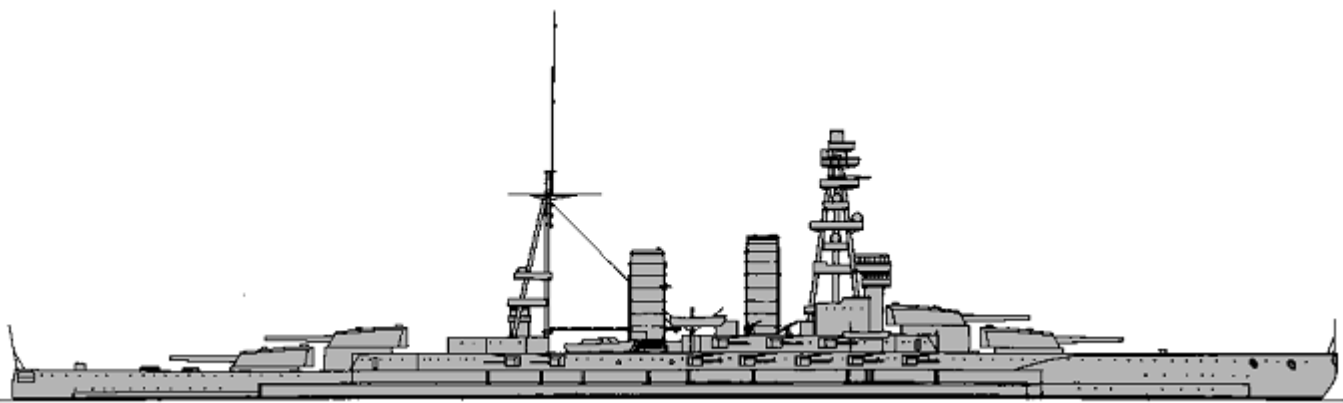
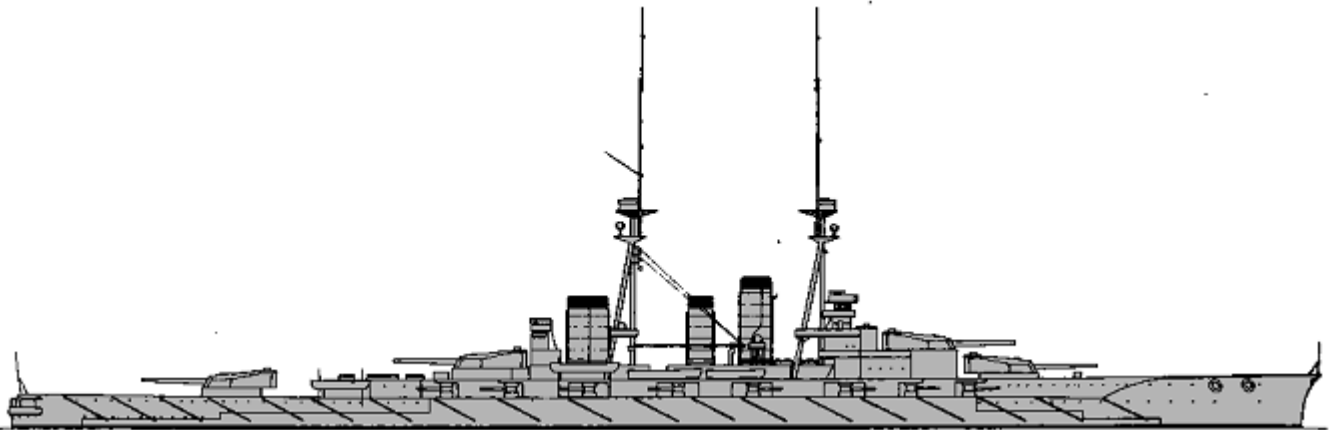
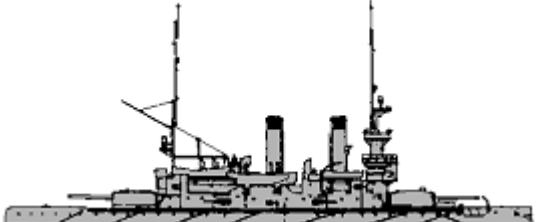
		1	Fuso	1915		<p>35900(1)-39154(2)t, 205.1x28.7x8.7m, 24b,4t, 40000hp, 22.5kts, 1193p; 305belt, 76deck, 305turrets, 350CT; 6x2-356/45, 16x1-152/50, 6x1-76/40, 6-533TT</p>
	Fuso	2	Yamashiro	1917		
		3	Ise	1917		<p>36500t, 208.2x28.7x8.8m, 24b,4t, 45000hp, 23kts, 1360p; 305belt, 51deck, 305turrets, 305CT; 6x2-356/45, 20x1-140/50, 4x1-76/40, 6-533TT</p>
BB	Ise	2	Hyuga	1918		
		5	Nagato	1920		<p>38500t, 215.8x29.0x9.1m, 21b,4gt, 80000hp, 26.5kts, 1333p; 305belt, 121deck, 356turrets, 356CT; 4x2-410/45, 20x1-140/50, 4x1-76/40, 8-533TT</p>
	Nagato	2	Mutsu	1921		

						
BC	Kongo	1	Kongo	1913		32200t, 214.5x28.0x8.4m, 36b,4t, 64000hp, 27.5kts, 1221p; 203belt, 57deck, 229turrets, 254CT; 4x2-356/45, 16x1-152/50, 7x1-76/40, 8-533TT
		2	Hiei	1914		
		3	Kirishima	1915		
		4	Haruna	1915		
BC	Mishima	1	Mishima	1897		5050t, 86.4x15.9x5.8m, 8b,2vte, 5750hp, 16kts, 404p; Harvey: 254belt, 76deck, 203turrets, 203CT; 2x2-254/45, 6x1-152/40

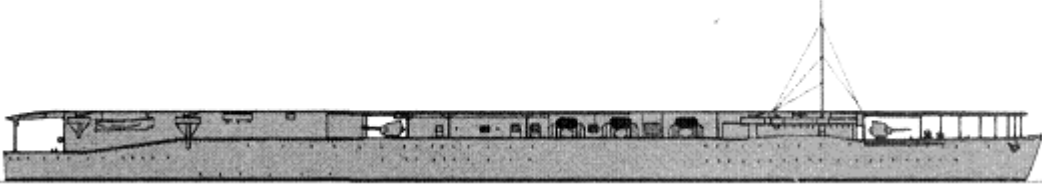
AIRCRAFT CARRYING SHIPS

CVL	Hosho	1	Hosho	1922		9630t, 168.1x22.7x6.2m, 8b,2t, 30000hp, 25kts, 550p; 4x1-140/50, 4x1-76/40, 26aircraft (7 1MF, 4 2MR, 6 1MT)
AV	Wakamiya	1	Wakamiya	1901		7720t, 111.3x14.7x5.8m, 3b,1vte, 1591hp, 10kts, 234p; 2x1-76/40, 2x1-47/40, 4seaplanes (really no)
		2	Notoro	1920		

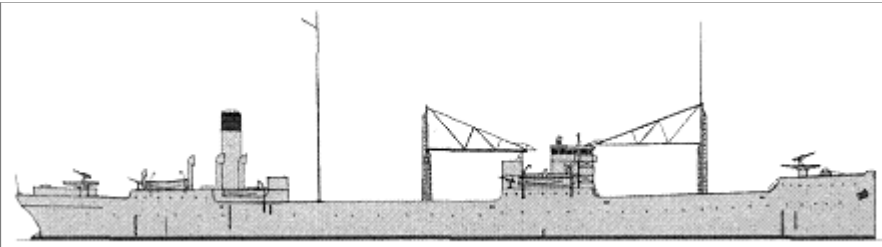
						
	Notoro	2				
			3	Tsurumi	1922	14050t, 138.9x17.7x8.1m, 4b,2vte, 5850hp, 12kts, 155p; 2x1-120/45, 2x1-76/40, 10seaplanes (W.33)

CRUISERS

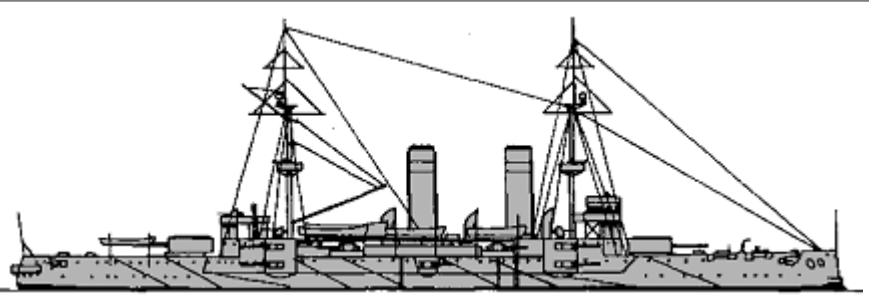
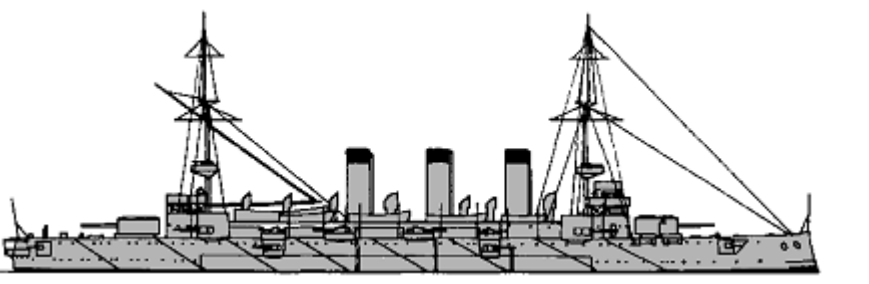
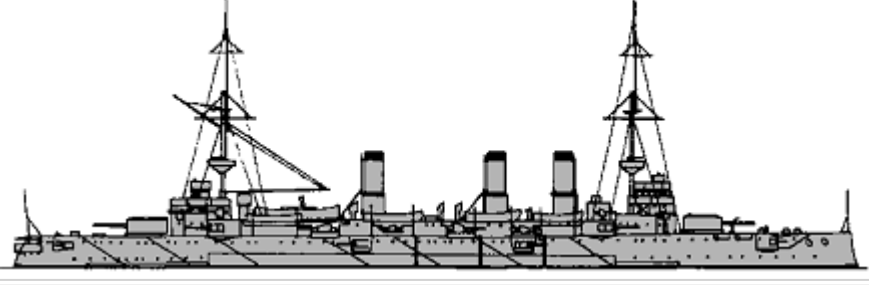
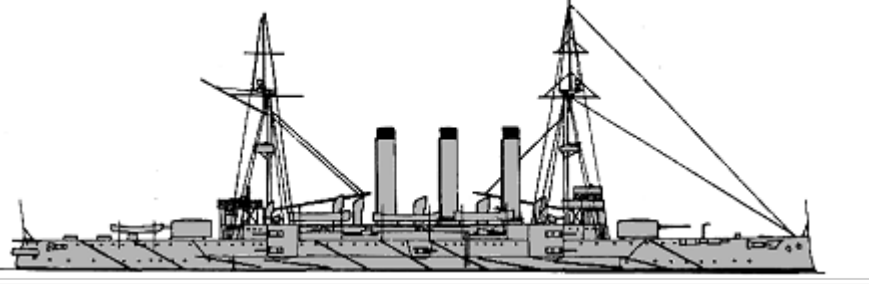
CA	Asama	1	1	Asama	1899		10500t, 134.7x20.5x7.4m, 16b,2vte, 18000hp, 21.5kts, 726p; Harvey: 178belt, 76deck, 152turrets, 356CT; 2x2-203/45, 14x1-152/40, 9x1-76/40, 3x1-47/30, 2-450TT
	Yakumo	1	2	Yakumo	1900		10300t, 132.3x19.6x7.2m, 24b,2vte, 15500hp, 20.5kts, 700p; 178belt, 63deck, 152turrets, 356CT; 2x2-203/45, 12x1-152/40, 9x1-76/40, 3x1-47/30, 2-450TT
	Azuma	1	3	Azuma (TS)	1900		9953t, 137.9x20.9x7.2m, 24b,2vte, 17000hp, 20kts, 650p; 178belt, 63deck, 152turrets, 356CT; 2x2-203/45, 12x1-152/40, 9x1-76/40, 8x1-47/40, 2-450TT
	Izumo	2	4	Izumo	1900		10300t, 132.3x20.9x7.4m, 24b,2vte, 14500hp, 20.8kts, 672p; 178belt, 63deck, 152turrets, 356CT; 2x2-203/45, 14x1-152/40, 9x1-76/40, 4x1-47/30, 2-450TT
			5	Iwate	1901		
	Kasuga	2	6	Kasuga	1904		8500t, 111.7x18.9x7.3m, 12b,2vte, 13500hp, 20kts, 600p; 150belt, 38deck, 150turrets, 150CT; 1x1-254/40(6), 1x2-203/45(6), 2x2-203/45(7), 4x1-152/40, 5x1-76/40, 4-450TT
			7	Nisshin	1904		

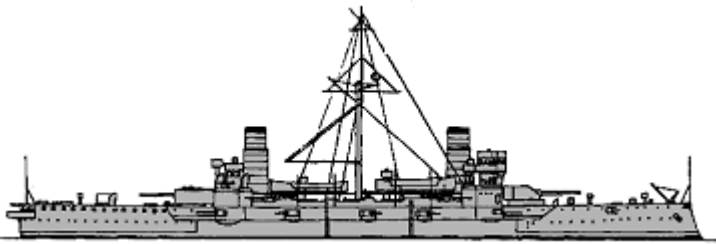
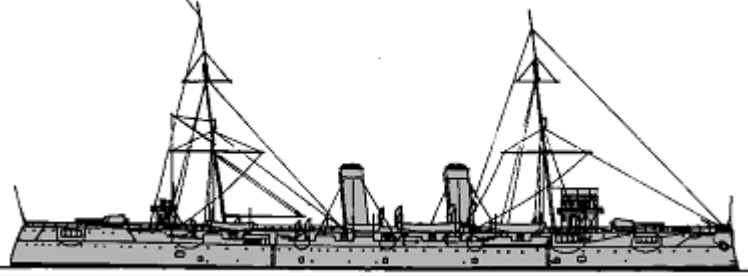
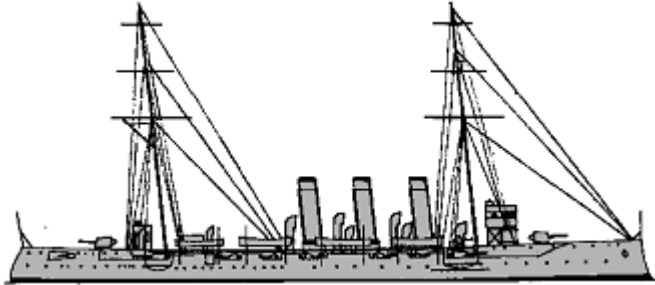
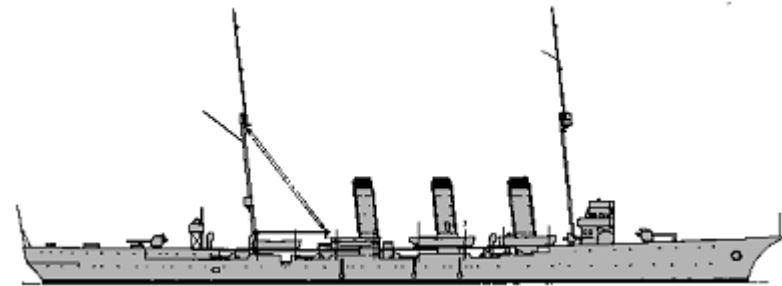
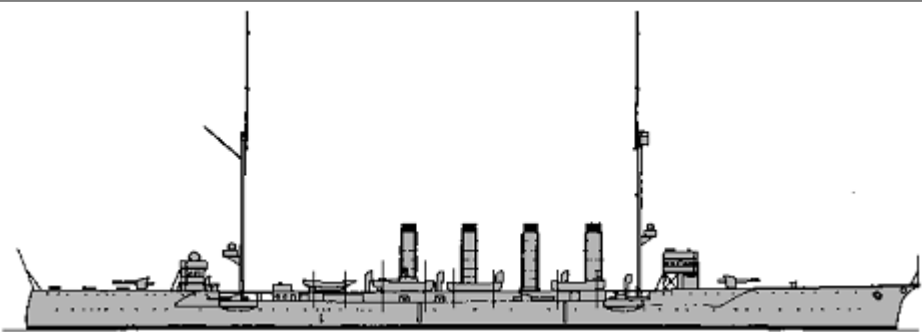
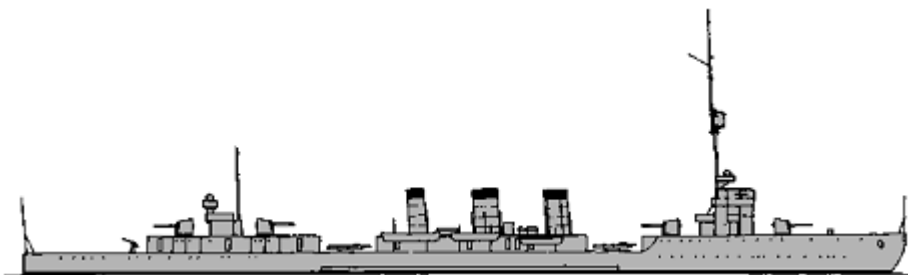

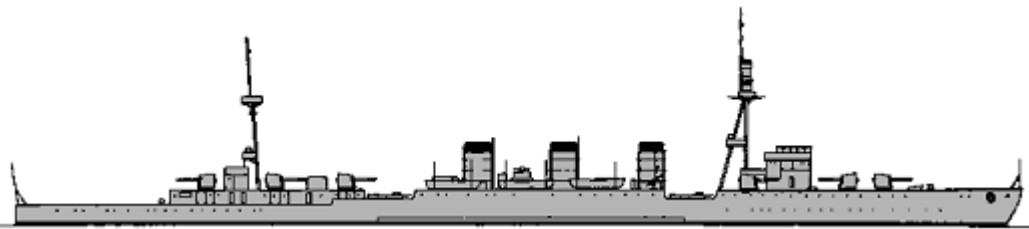
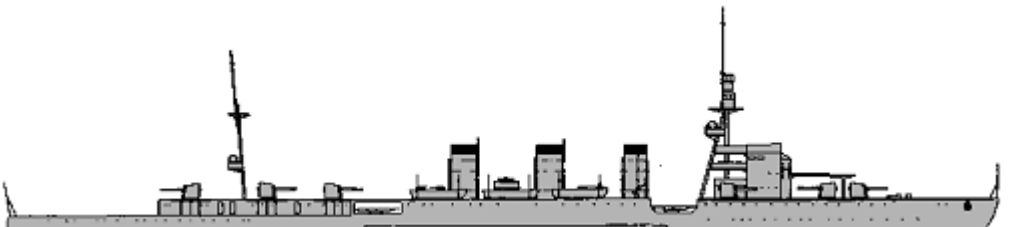
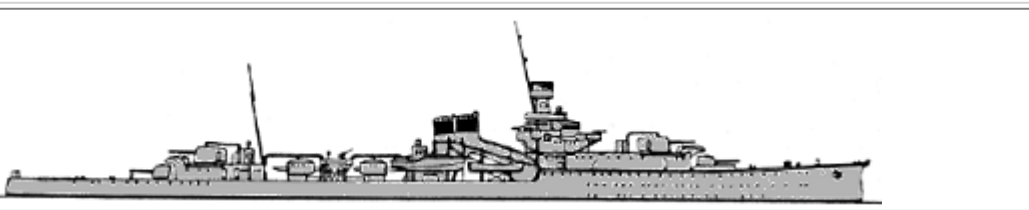
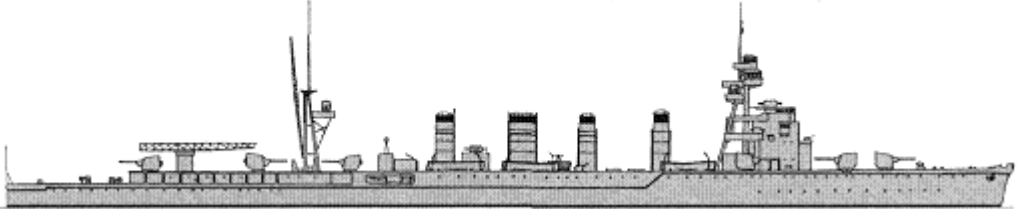

						
	Chitose	1 1	Chitose	1899		5598t, 120.4x15.0x5.4m, 8b,2vte, 15000hp, 22.5kts, 434p; Harvey: 114slopes, 45deck, 114shields, 114CT; 2x1-203/45, 10x1-120/40, 11x1-76/40, 6x1-47/30, 5-356TT
	Tsushima	1 2	Tsushima	1904		3716t, 104.1x13.4x4.9m, 16b,2vte, 9500hp, 20kts, 320p; Harvey: 64slopes, 25shields, 102CT; 6x1-152/40, 9x1-76/40
	Tone	1 3	Tone	1910		4900t, 123.2x14.4x5.1m, 16b,2vte, 15000hp, 23kts, 370p; 76deck, 25shields, 102CT; 2x1-152/45, 8x1-120/40, 6x1-76/40, 3-450TT
CL	Chikuma	4	Chikuma	1912		5040t, 144.8x14.2x5.1m, 6b,2t, 22500hp, 26kts, 414p; 89belt, 57deck, 25shields, 102CT; 8x1-152/45, 6x1-76/40, 2x2-533TT
		5	Hirado	1912		
		6	Yahagi	1912		
	Tenryu	2	Tenryu	1919		4350t, 142.9x12.3x4.0m, 10b,3gt, 51000hp, 33kts, 327p; 63belt, 25deck, 20shields, 51CT; 4x1-140/50, 1x1-76/40, 2x3-533TT, 48m
		8	Tatsuta	1919		



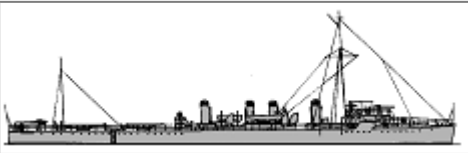
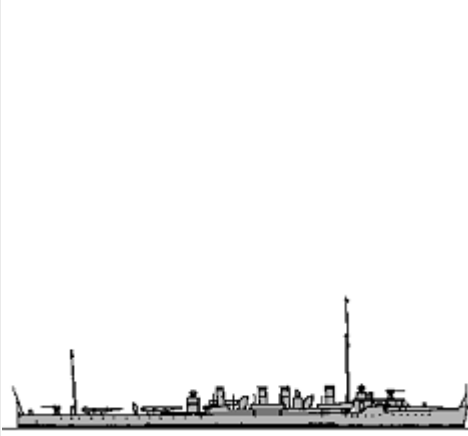

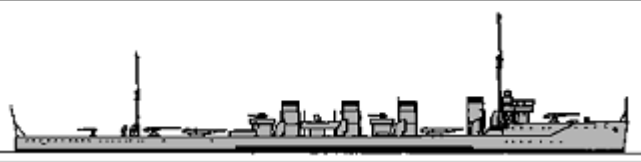
Kuma	5	9	Kuma	1920		5832t, 162.2x14.2x4.8m, 12b,4gt, 90000hp, 36kts, 450p; 63belt, 29deck, 20shields, 51CT: 7x1-140/50, 2x1-76/40, 4x2-533TT, 48m
		10	Tama	1921		
		11	Kitakami	1921		
		12	Oi	1921		
		13	Kiso	1921		
Nagara	5	14	Nagara	1922		7050t, 162.2x14.2x4.8m, 12b,4gt, 90000hp, 36kts, 450p; 63belt, 29deck, 20shields, 51CT; 7x1-140/50, 2x1-76/40, 4x2-610TT, 48m, 1seaplane (HD-26)
		15	Isuzu	1923		
		16	Natori	1922		
		17	Yura	1923		
		18	Kinu	1922		
Yubari	1	19	Yubari	1923		4400t, 138.9x12.0x3.6m, 8b,3gt, 57750hp, 35.5kts, 328p; 57belt, 25deck, 25turrets; (2x2+2x1)-140/50, 1x1-76/40, 2x2-610TT, 48m
Sendai	1	20	Sendai	1924		7100t, 163.0x14.2x4.9m, 12b,4gt, 90000hp, 35.2kts, 450p; 64belt, 29deck, 25shields; 7x1-140/50, 2x1-76/40, 4x2-610TT, 48m, 1seaplane (HD-26)

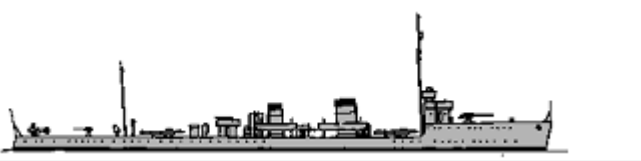
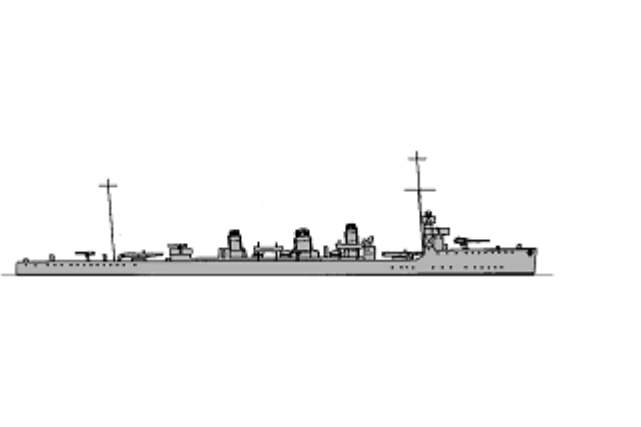
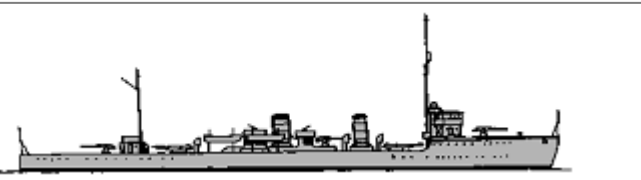
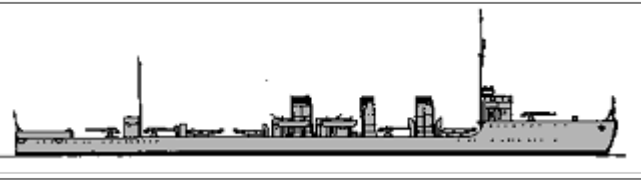
### TORPEDO SHIPS



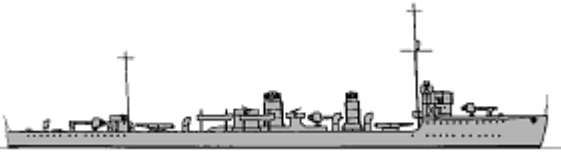
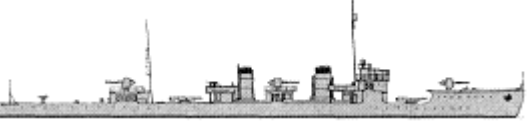



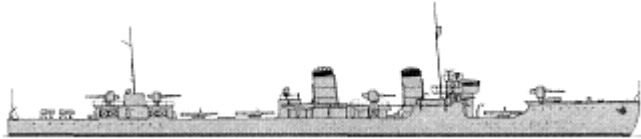
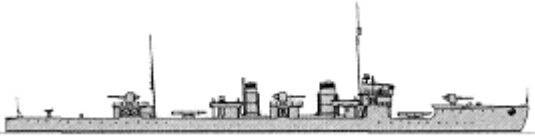

Harusame	2	1	Ariake	1905		435t, 71.4x6.6x1.8m, 4b,2vte, 6000hp, 29kts, 55p; 2x1-76/40, 4x1-57/40, 2x1-450TT
		2	Fubuki	1905		
Asakaze	17	3	Yayoi	1905		450t, 72.0x6.6x1.8m, 4b,2vte, 6000hp, 29kts, 70p; 2x1-76/40, 4x1-76/23, 2x1-450TT
		4	Oite	1906		
		5	Mikazuki	1906		
		6	Shigure	1906		
		7	Hatsuharu	1907		
		8	Shiratsuyu	1906		
		9	Shirayuki	1906		
		10	Matsukaze	1907		
		11	Nagatsuki	1907		
		12	Yunagi	1906		
		13	Uzuki	1907		
		14	Minazuki	1907		

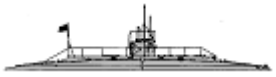

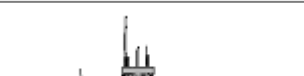



		15	Hayate	1907		
		16	Kikuzuki	1907		
		17	Uranami	1908		
		18	Isonami	1909		
		19	Ayanami	1909		
Umikaze	2	20	Umikaze	1911		1150t, 98.5x8.5x2.7m, 8b,3t, 20500hp, 33kts, 140p; 2x1-120/40, 5x1-76/40, 2x2-450TT(20), 3x1-450TT(21)
		21	Yamakaze	1911		
Sakura	2	22	Sakura	1912		830t, 83.6x7.3x2.2m, 5b,3vte, 9500hp, 30kts, 92p; 1x1-120/40, 4x1-76/40, 2x2-450TT
		23	Tachibana	1912		
Urakaze	1	24	Urakaze	1915		1085t, 87.2x8.4x2.4m, 3b,2t, 22000hp, 30kts, 120p; 1x1-120/40, 4x1-76/40, 2x2-533TT
Kaba	10	25	Kaba	1915		850t, 83.6x7.3x2.3m, 4b,3vte, 9500hp, 30kts, 92p; 1x1-120/40, 4x1-76/40, 2x2-450TT
		26	Matsu	1915		
		27	Kashiwa	1915		
		28	Katsura	1915		
		29	Kaede	1915		
		30	Kiri	1915		
		31	Kusunoki	1915		
		32	Ume	1915		
		33	Sakaki	1915		
		34	Sugi	1915		
Momo	4	35	Momo	1916		1080t, 85.6x7.7x2.3m, 4b,2gt, 16000hp, 31.5kts, 110p; 3x1-120/40, 2x3-450TT
		36	Kashi	1917		
		37	Hinoki	1917		
		38	Yanagi	1917		
Amatsukaze	4	39	Amatsukaze	1917		1570t, 96.9x8.5x2.8m, 5b,3t, 27000hp, 34kts, 128p; 4x1-120/40, 3x2-450TT
		40	Isokaze	1917		
		41	Tokitsukaze	1917		
		42	Hamakaze	1917		
Kawakaze	2	43	Kawakaze	1918		1580t, 103.6x8.8x2.8m, 4b,2gt(43)-2t(44), 34000hp, 37.5kts, 128p; 3x1-120/45, 2x3-533TT
		44	Tanikaze	1919		
DD		45	Enoki	1918		
		46	Nara	1918		

Enoki	6	47	Tsubaki	1918		1100t, 85.8x7.7x2.3m, 4b,2gt, 17500hp, 31.5kts, 110p; 3x1-120/40, 2x3-450TT
		48	Kuwa	1918		
		49	Keyaki	1918		
		50	Maki	1918		
Momi	21	51	Momi	1919		1020t, 85.3x7.9x2.4m, 3b,2gt, 21500hp, 36kts, 110p; 3x1-120/45, 2x2-533TT, 20m, MS
		52	Kaya	1920		
		53	Nire	1920		
		54	Nashi	1919		
		55	Take	1919		
		56	Kaki	1920		
		57	Kuri	1920		
		58	Tsuga	1920		
		59	Fuji	1921		
		60	Kiku	1920		
		61	Aoi	1920		
		62	Hagi	1921		
		63	Susuki	1921		
		64	Ashi	1921		
65	Tsuta	1921				
66	Warabi	1921				
67	Hasu	1922				
68	Hishi	1922				
69	Sumire	1923				
70	Yomogi	1922				
71	Tade	1922				
Minekaze	15	72	Minekaze	1920		1650t, 102.6x9.0x2.9m, 4b,2gt, 38500hp, 39kts, 148p; 4x1-120/45, 3x2-533TT, 20m
		73	Sawakaze	1920		
		74	Okikaze	1920		
		75	Hakaze	1920		
		76	Yakaze	1920		
		77	Nadakaze	1921		
		78	Shimakaze	1920		
		79	Akikaze	1921		
		80	Shiokaze	1921		
		81	Yukaze	1921		
82	Hokaze	1921				
83	Tachikaze	1921				
84	Nokaze	1922				
85	Namikaze	1922				
86	Numakaze	1922				

1-go	5	87	1-go	1922		1720t, 102.6x9.1x2.9m, 4b,2gt, 38500hp, 37.2kts, 148p; 4x1-120/45, 3x2-533TT, 20m, MS
		88	3-go	1923		
		89	5-go	1923		
		90	7-go	1924		
		91	9-go	1924		
2-go	8	92	2-go	1922		1100t, 85.3x7.9x2.5m, 3b,2gt, 21500hp, 35.5kts, 110p; 3x1-120/45, 2x2-533TT, 20m, MS
		93	4-go	1922		
		94	6-go	1923		
		95	8-go	1924		
		96	10-go	1923		
		97	12-go	1924		
		98	16-go	1923		
		99	18-go	1923		

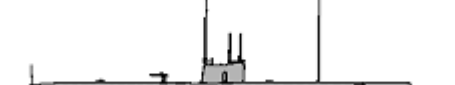
## SUBMARINES

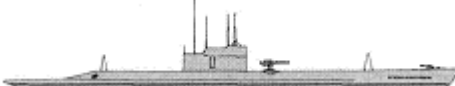
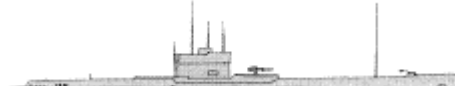
C-1	2	1	HA1	1909		286/321t, 43.3x4.1x3.4m, 1pe/em, 600/300hp, 12/8.5kts, 26p, 30m; 2-450TT
		2	HA2	1909		
C-2	3	3	HA3	1911		291/326t, 43.3x4.1x3.4m, 1pe/em, 600/300hp, 12/8.5kts, 25p, 30m; 2-450TT
		4	HA4	1911		
		5	HA5	1911		
VK	1	6	HA6	1912		304/340t, 38.6x3.8x3.1m, 1pe/em, 1000/300hp, 10.8/8kts, 26p, 30m; 2-450TT
C-3	2	7	HA7	1916		290/326t, 43.7x4.1x3.4m, 1pe/em, 600/300hp, 12/8.5kts, 26p, 30m; (2+2x1)-450TT
		8	HA8	1917		
S-2	1	9	HA9	1920		480/737t, 58.6x5.2x3.3m, 2d/em, 1800/850hp, 16.5/9.5kts, 30p, 30m; 1x1-76/40, 4-450TT, 2-450TR
S-1	1	10	HA10	1917		418/665t, 56.7x5.2x3.1m, 2d/em, 2000/850hp, 17/10kts, 30p, 30m; 1x1-76/40, 4-450TT, 4-450TR
K-1	2	11	RO11	1919		735/1030t, 69.2x6.4x3.4m, 2d/em, 2600/1200hp, 18/9kts, 44p, 30m; 1x1-76/23, 4-450TT, 2-450TR
		12	RO12	1919		
F-1	2	13	RO1	1920		689/1047t, 65.6x6.1x4.2m, 2d/em, 2800/1200hp, 13/8kts, 43p, 40m; 1x1-76/23, 5-450TT
		14	RO2	1920		
K-2	3	15	RO13	1920		755/1050t, 70.1x6.1x3.7m, 2d/em, 2600/1200hp, 17/9kts, 45p, 45m; 1x1-76/23, 4-450TT, 2-450TR
		16	RO14	1921		
		17	RO15	1921		
L-1	2	18	RO51	1920		893/1195t, 70.6x7.2x3.9m, 2d/em, 2400/1600hp, 17/8kts, 48p, 60m; 1x1-76/23, 6-450TT

SS	K-3	10	19	RO52	1920		
			20	RO16	1922		755/1050t, 70.1x6.1x3.7m, 2d/em, 2600/1200hp, 17/9kts, 45p, 45m; 1x1-76/23, 4-450TT, 2-450TR
			21	RO17	1921		
			22	RO18	1921		
			23	RO19	1922		
			24	RO20	1922		
			25	RO21	1922		
			26	RO22	1922		
			27	RO23	1923		
			28	RO24	1920		
	29	RO25	1921				
	L-2	4	30	RO53	1921		893/1195t, 70.6x7.1x3.9m, 2d/em, 2400/1600hp, 17/8kts, 48p, 60m; 1x1-76/23, 4-450TT
			31	RO54	1921		
			32	RO55	1921		
			33	RO56	1922		
	F-2	3	34	RO3	1922		689/1047t, 65.6x6.1x4.1m, 2d/em, 2600/1200hp, 14/8kts, 43p, 40m; 1x1-76/23, 5-450TT
			35	RO4	1922		
			36	RO5	1922		
	L-3	3	37	RO57	1922		897/1195t, 76.2x7.2x4.0m, 2d/em, 2400/1600hp, 17/8kts, 48p, 60m; 1x1-76/23, 4-533TT
			38	RO58	1922		
			39	RO59	1923		
	K-4	3	40	RO26	1923		770/1080t, 74.2x6.1x3.7m, 2d/em, 2600/1200hp, 17/9kts, 45p, 45m; 1x1-76/23, 4-533TT
			41	RO27	1924		
			42	RO28	1923		
	KT	3	43	RO29	1923		665/1030t, 74.2x6.1x3.7m, 2d/em, 1200/1200hp, 13/8kts, 43p, 75m; 1x1-120/45, 4-533TT
			44	RO30	1924		
			45	RO32	1924		
	L-4	4	46	RO60	1923		996/1322t, 76.2x7.4x3.8m, 2d/em, 2400/1600hp, 16.5/9kts, 60p, 60m; 1x1-76/40, 6-533TT
			47	RO61	1924		
48			RO62	1924			
49			RO63	1924			
KD-1	1	50	I51	1924		1500/2430t, 91.4x8.8x4.6m, 4d/em, 5200/2000hp, 20/10kts, 60p, 60m; 1x1-120/45, 1x1-76/40, 8-533TT	

OTHER FIGHTING SHIPS

--	--	--	--	--	--	--	--

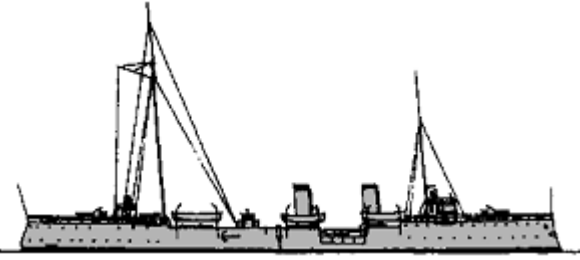
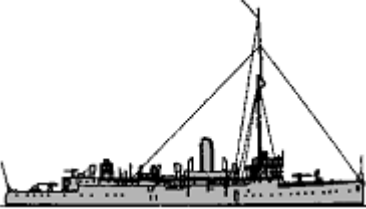
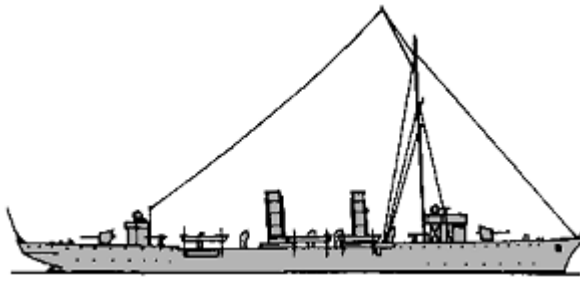
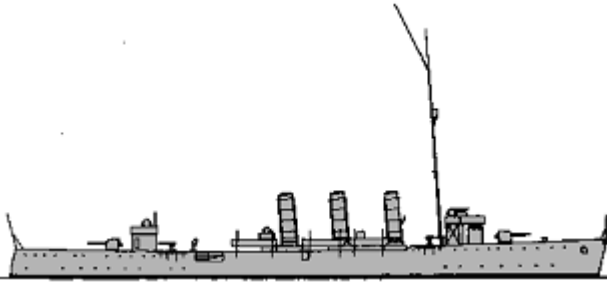
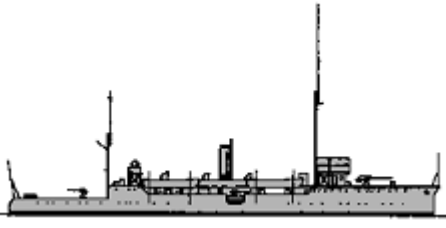
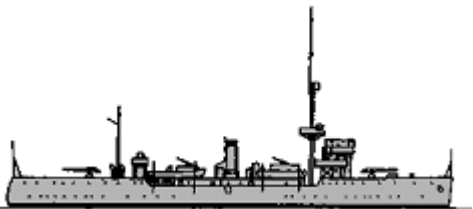
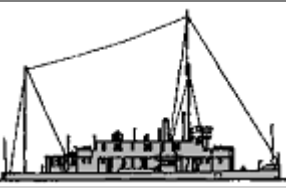

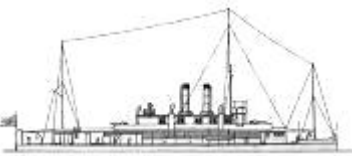
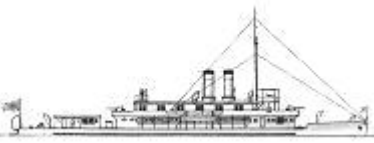
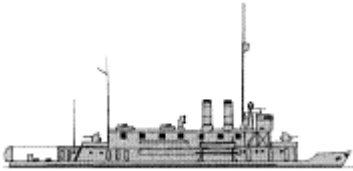
PG	Chihaya	1	1	Chihaya	1901		1464t, 87.7x9.6x2.8m, 4b,2vte, 6000hp, 21kts, 125p; 2x1-120/40, 4x1-76/40, 2x1-450TT
	Uji	1	2	Uji	1903		620t, 57.8x8.4x2.1m, 2b,2vte, 1000hp, 13kts, 86p; 4x1-76/40
	Yodo	1	3	Yodo	1908		1250t, 93.1x9.8x3.0m, 4b,2vce, 6500hp, 22kts, 180p; 63deck, 51CT; 2x1-120/40, 4x1-76/40, 2x1-450TT
	Mogami	1	4	Mogami	1908		1350t, 96.3x9.8x3.0m, 6b,3t, 8000hp, 23kts, 180p; 63deck, 51CT; 2x1-120/40, 4x1-76/40, 2x1-450TT
	Saga	1	5	Saga	1912		885t, 69.0x9.0x2.2m, 2b,2vte, 1600hp, 15kts, 98p; 1x1-120/45, 3x1-76/40
	Ataka	1	6	Ataka	1923		1133t, 71.7x9.0x2.3m, 2b,2vte, 1700hp, 16kts, 118p; 2x1-120/45, 2x1-76/40
	Sumida	1	1	Sumida	1906		126t, 44.2x7.2x0.6m, 2b,3vte, 550hp, 13kts, 40p; 2x1-47/40



PR	Fushimi	1	2	Fushimi	1906		180t, 48.7x7.4x0.7m, 2b,3vte, 900hp, 14kts, 45p; 2x1-57/40
	Toba	1	3	Toba	1911		291t, 55.9x8.2x0.8m, 2b,3vte, 1400hp, 15kts, 59p; 2x1-76/23
	Seta	4	4	Seta	1923		400t, 56.1x8.2x1.0m, 2b,2vce, 2100hp, 16kts, 62p; 2x1-76/40
5			Kataka	1923			
6			Hira	1923			
7			Hozu	1923			

### COASTAL FORCES

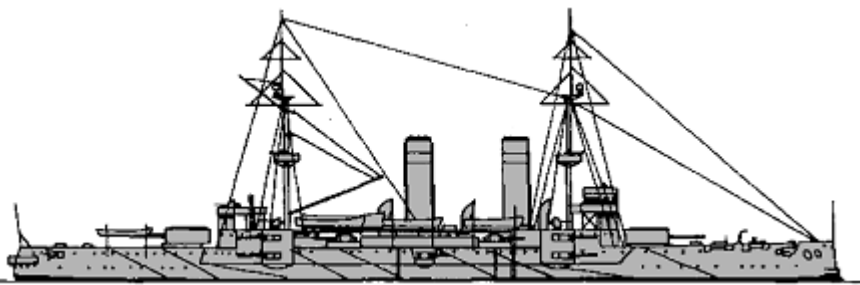
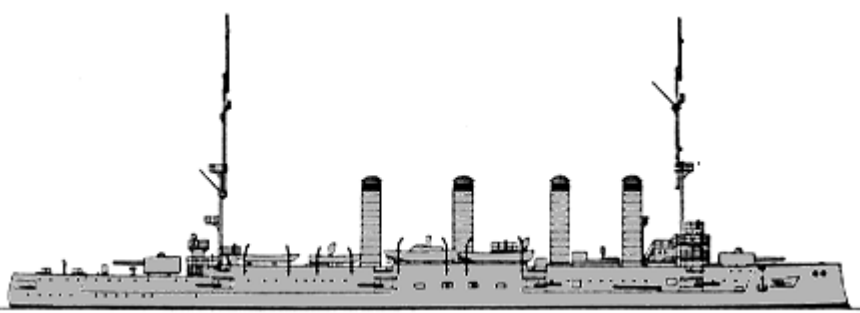
PT	CMB-55	4	1 - 4	No615, 1149 and 2 others	1920		14t, 16.8x3.4x1.0m, 2pe, 1000hp, 40kts, 5p; 2-450TR, 1DCR
----	--------	---	-------	--------------------------	------	---	---

### MINE WARFARE

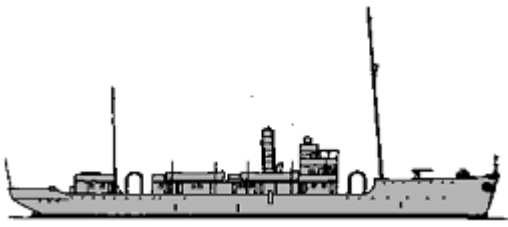
	Tokiwa	1	1	Tokiwa	1899		10500t, 134.7x20.5x7.4m, 16b,2vte, 18000hp, 21.5kts, 726p; Harvey: 178belt, 76deck, 152turrets, 356CT; 1x2-203/45, 8x1-152/40, 3x1-76/40, 300m
	Aso	1	2	Aso	1903		7800t, 137.0x17.5x6.5m, 26b,2vte, 16500hp, 21kts, 593p; Harvey: 200belt, 50deck, 60casemates, 160CT; 2x1-152/50, 8x1-152/45, 16x1-76/40, 420m
ML			3	Natsushima	1912		435t, 45.7x7.6x2.3m, 1b,1vte, 600hp, 12.8kts, 40p; 2x1-76/40, 60m, MS
			4	Sokuten	1913		
			5	Toshima	1915		
			6	Kuroshima	1915		
			7	Ashizaki	1916		
			8	KAtoku	1916		
	Natsushima	13	9	Kurokami	1917		

							
		10	Katashima	1917			
		11	Ento	1917			
		12	Enoshima	1919			
		13	Kurosaki	1921			
		14	Ninoshima	1920			
		15	Washizaki	1921			
	Katsuriki	1	16	Katsuriki	1917		2000t, 73.1x11.9x4.3m, 2b,2vte, 1800hp, 13kts; 3x1-76/40, 150m
MS	Asakaze	1	Asakaze	1906		450t, 72.0x6.6x1.8m, 4b,2vte, 6000hp, 29kts, 70p; 2x1-120/40, 2x1-76/40, MS	
		2	Wakaba	1906			
		3	Ushio	1905			
		4	Nenohi	1905			
		5	Kisaragi	1905			
		6	Kamikaze	1905			
		7	Hatsushimo	1906			
		8	Yugure	1906			
		9	Harukaze	1906			
		10	Hibiki	1906			
		11	Hatsuyuki	1906			
		12	Yudachi	1906			
		W1	3	13	W1	1923	
			14	W2	1923		
			15	W3	1923		

NAVAL AVIATION (approximately, maximal number of delivered planes signed)

Deck planes	F: 138 1MF1/3/4 (delivery till 1928); TB: 20 1MT1N, 196 2MT2/3 (delivery till 1929), 116 2MT5 (delivery till 1929); R: 159 2MR1/2/4 (delivery till 1929)
Seaplanes	R: 10 W.33, 90 E1Y1 (delivery till 1928)



© Ivan Gogin, 2011-14

[home](#)

[World navies yesterday](#)

[1925](#)

## Latvia 01 January 1925

### ESCORTS

PC	Virsaitis	1	1	Virsaitis	1917		539t, 59.3x7.4x2.2m, 2b,2vte, 1850hp, 16kts, 51p; 2x1-88/45, 30m, MS
----	-----------	---	---	-----------	------	--	--

© Ivan Gogin, 2011-15

[home](#)

[World navies yesterday](#)

[1925](#)

## Mexico 01 January 1925

### CAPTAL SHIPS

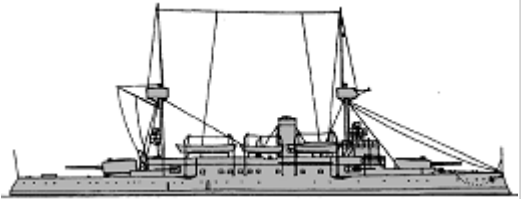
BC	Anahuac	1	1	Anahuac	1900		3162t, 81.5x14.4x4.2m, 8b,2vte, 3400hp, 15kts, 200p; Harvey steel; 350belt, 45deck, 220turrets, 125CT; 2x1-234/45, 4x1-120/50, 6x1-57/40, 2-450TT
----	---------	---	---	---------	------	--	---

### CRUISERS

CLP	Progreso	1	1	Progreso	1907		1700t, 70.1x10.3x3.0m, 1vte, 1400hp, 13kts, 140p; 4x1-57/40, troops
-----	----------	---	---	----------	------	--	---

### ESCORTS

TL	Salinas	4	1	Salinas	1917	No picture	486t, 40.5x7.1x4.1m, 1b,1vte, 557hp, 7kts, 26p; 1x1-57/40(2,3), 2x1-40/39(2,3), 1x1-25/60(1,4), 1x1-13.2(1,4)
			2	Mazatlan	1917		
			3	Tampico	1917		
			4	Vera Cruz	1917		

### OTHER FIGHTING SHIPS

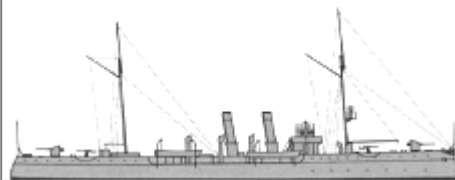
PG	Nicholas Bravo	1	1	Nicholas Bravo	1904		1493t, 73.8x10.4x3.0m, 2vte, 2565hp, 17kts, 116p; 2x1-102/40, 6x1-57/40, 1-356TT
----	----------------	---	---	----------------	------	--	--

	Agua Prieta	1	2	Agua Prieta	1893		1318t, 62.2x9.8x3.7m, 2b,2vte, 1900hp, 15.5kts, 157p; 8x1-102/40, 2x1-57/40
--	-------------	---	---	-------------	------	---	---

© Ivan Gogin, 2011-15

[home](#)[World navies yesterday](#)[1925](#)

# NETHERLANDS 01 January 1925



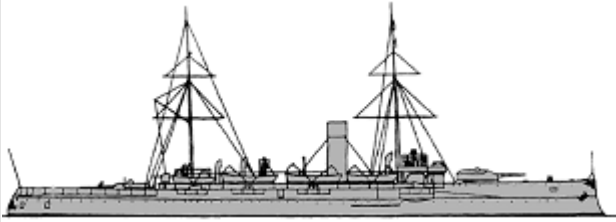
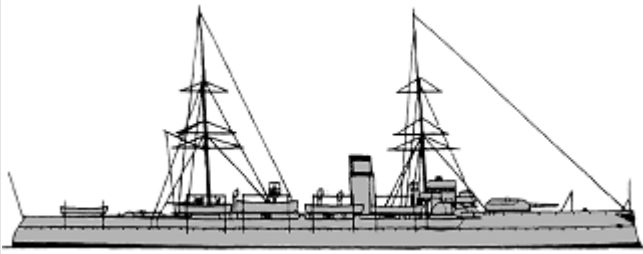
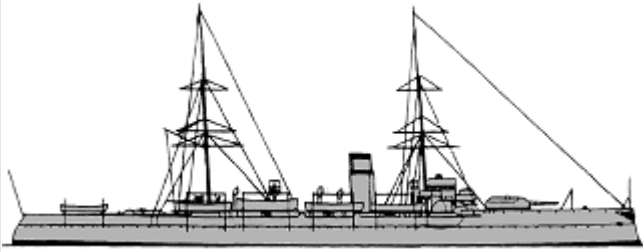
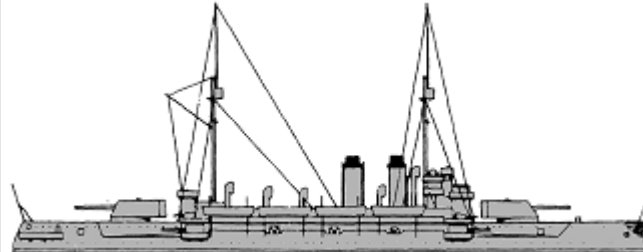

## CAPITAL SHIPS

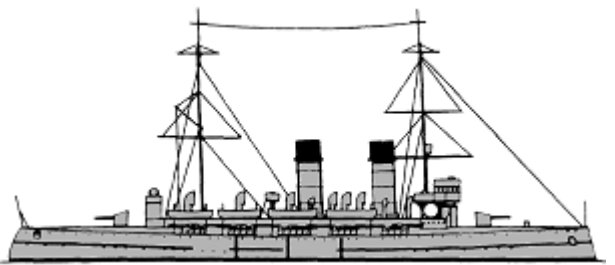
BC	Koningin Regentes	1	1	Hertog Hendrik	1904		5084t, 96.6x15.2x6.8m, 6b,2vte, 6500hp, 16.5kts, 340p; 152belt, 51deck, 102turrets, 246CT; 2x1-240/40, 4x1-150/40, 8x1-75/55, 3-450TT
	Marten Harpertzoon Tromp	1	2	Marten Harpertzoon Tromp	1905		5295t, 100.8x15.2x5.7m, 8b,2vte, 6400hp, 16.5kts, 340p; 152belt, 51deck, 102turrets, 194CT; 2x1-240/40, 4x1-150/40, 8x1-75/55, 3-450TT
	Jacob van Heemskerck	1	3	Jacob van Heemskerck	1908		4920t, 98.0x15.2x5.7m, 8b,2vte, 6400hp, 16.5kts, 340p; 152belt, 51deck, 102turrets, 194CT; 2x1-240/40, 6x1-150/40, 6x1-75/55, 2-450TT
	De Zeven Provinciën	1	4	De Zeven Provinciën	1910		6510t, 103.5x17.1x6.2m, 8b,2vte, 8000hp, 16kts, 448p; 150belt, 50deck, 250turrets, 200CT; 2x1-283/43, 4x1-150/40, 10x1-75/55



## CRUISERS





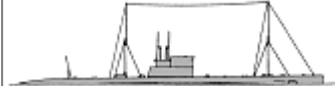

CL	Holland	1	1	Gelderland	1900		3970t, 94.7x14.8x5.4m, 10b,2vte, 10000hp, 20kts, 371p; Harvey; 57deck, 152shields, 102CT; 8x1-120/40, 4x1-75/55
----	---------	---	---	------------	------	---	---

### TORPEDO SHIPS

DD	Fret	6	1	Bulhond	1912		510t, 70.4x6.6x2.0m, 4b,2t, 8500hp, 30kts, 83p; 4x1-75/40, 2x1-450TT
			2	Jakhals	1912		
			3	Hermelijn	1913		
			4	Lynx	1913		
			5	Panter	1914		
			6	Vos	1914		
TB	G13	3	1	G13	1914		230t, 49.5ppx5.3x1.5m, 2b,2vte, 2600hp, 25kts, 27p; 2x1-75/30, 3x1-450TT
			2	G15	1914		
			3	G16	1914		
	Z5	4	4	Z5	1917		310t, 58.5ppx6.1x1.7m, 3b,2vte, 5500hp, 27kts, 46p; 2x1-75/30, 2x1-12.7, (1x2+2x1)-450TT
			5	Z6	1917		
			6	Z7	1916		
			7	Z8	1916		
	Z1	4	8	Z1	1919		322t, 62.6x6.2x1.9m, 3b,2t, 5500hp, 27kts, 46p; 2x1-75/30, 2x1-12.7, (1x2+2x1)-450TT
			9	Z2	1921		
			10	Z3	1920		
			11	Z4	1920		

### SUBMARINES

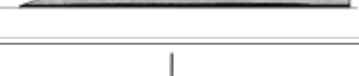
O2	4	1	O2	1911		130/150t, 32.1x3.3x2.7m, 1d/em, 350/200hp, 11/8.6kts, 10p, 25m; 2-450TT
		2	O3	1913		
		3	O4	1914		
		4	O5	1914		
K I	1	5	K I	1914		330/386t, 48.6x4.7x3.0m, 2d/em, 1800/500hp, 17/10.5kts, 17p, 40m; 3-450TT
O6	1	6	O6	1916		189/229t, 35.7x4.1x3.1m, 1d/em, 375/185hp, 12/8.5kts, 15p, 40m; 3-450TT
O7	1	7	O7	1916		176/206t, 34.7x3.9x2.9m, 1d/em, 350/185hp, 11.5/8.5kts, 15p, 40m; 3-450TT

SS	M1	1	8	M1	1915		168/183t, 34.0x3.2x3.0m, 1d/em, 90/175hp, 6.2/5.2kts, 14p, 50m; 12m
	O8	1	9	O8	1915		364/434t, 45.8x4.7x3.8m, 2d/em, 480/620hp, 13/11kts, 22p, 50m; 4-450TT
	K III	2	10	K III	1920		583/721t, 64.4x5.6x3.6m, 2d/em, 1800(10)-1200(11)/630hp, 16.5(10)-15(11)/8.5kts, 29p, 40m; 1x1-75/55, (4+1x2)-450TT
			11	K IV	1921		
	K V	3	12	K V	1920		569/649t, 57.3x5.6x3.8m, 2d/em, 1200/400hp, 13.5/8kts, 31p, 40m; 1x1-75/55, (4+1x2)-450TT
			13	K VI	1921		
			14	K VII	1922		
K II	1	15	K II	1922		569/649t, 57.3x5.3x3.8m, 2d/em, 1800/500hp, 15.5/8.5kts, 29p, 40m; 1x1-75/55, (4+1x2)-450TT	
K VIII	3	16	K VIII	1922		583/810t, 64.4x5.6x3.6m, 2d/em, 1800(16)-1550(17,18)/400hp, 16(16)-15(17,18)/8kts, 31p, 50m; 1x1-88/45, 4-450TT	
		17	K IX	1923			
		18	K X	1923			

## ESCORTS

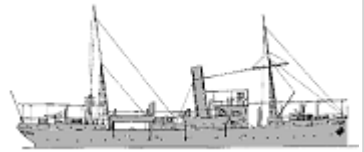
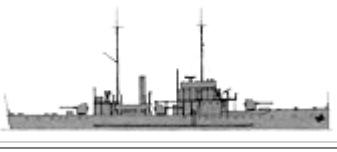

PC	Albatros	1	1	Albatros	1912	No picture	892t, 50.0ppx9.4x3.3m, 1vte, 1140hp, 12kts, 47p; 2x1-37/45
	Orion	1	2	Orion	1912	No picture	1062t, 55.9ppx9.0x3.7m, 1vte, 1380hp, 14kts, 71p; 2x1-75/55
	Aldebaran	1	3	Aldebaran	1913	No picture	892t, 53.3ppx8.2x3.5m, 1vte, 800hp, 12kts, 45p; 2x1-37/45
	Bellatrix	3	4	Bellatrix	1914	No picture	773t, 53.3ppx9.0x3.0m, 1vte, 800hp, 12kts, 45p; 1x1-75/55(4), 2x1-37/45(5,6)
			5	Canopus	1915		
			6	Deneb	1915		
	Eridanus	1	7	Eridanus	1918	No picture	996t, 56.5ppx9.0x3.2m, 1vte, 800hp, 12kts, 44p; 1x1-75/55
	Gemma	1	8	Gemma	1918	No picture	845t, 53.3ppx9.0x3.2m, 1vte, 800hp, 12kts, 44p; 1x1-75/55
	Sirius	2	9	Sirius	1922	No picture	1015t, 55.6ppx9.5x3.3m, 1vte, 900hp, 12.5kts, 50p; 1x1-75/55
10			Wega	1922			
Fomalhaut	1	11	Fomalhaut	1923	No picture	1001t, 56.9ppx9.5x3.4m, 1vte, 855hp, 12.5kts, 55p; 2x1-37/45	

## OTHER FIGHTING SHIPS

PG	Koetei	1	1	Koetei	1898		788t, 53.7x9.4x3.7m, 2vte, 1380hp, 13.7kts, 97p; 2x1-105/35, 4x1-37/23, 2x5-37/20
	Brinio	3	2	Brinio	1914		634(2)-573(3)-581(4)t, 52.7x8.5x2.8m, 2d, 1200(2,3)-1500(4)hp, 14kts, 52p; 55belt, 17deck, 50shields, 50CT; 4x1-105/50, 2x1-12.7
			3	Friso	1915		
			4	Gruno	1915		
K1	1	1	K2 Christiaan Cornelis	1905	No picture	47t, 30.0x3.6x1.7m, 1b,1vte, 560hp, 18.7kts, 12p; 2x1-37/23	
		2	Los	1875			

PR	Hydra	2	3	Sperwer (TS)	1875		218t, 25.9x8.2x2.3m, 2b,1vce, 146hp, 8kts, 34p; 1x1-210/35, 2x1-37/23, 1x5-37/20
			4	Braga	1879		280t, 27.8x8.2x2.3m, 2b,1vce, 171hp, 8.3kts, 34p; 1x1-280/22(4-7), 1x1-280/30(9), 1x1-120/40(8), 2x1-37/23, 1x5-37/20
	5	Freyr	1877				
	6	Njord	1878				
	7	Tyr	1878				
	8	Hefring (TS)	1880				
	9	Bulgia	1884				
	Wodan	6	4	Braga	1879		
			5	Freyr	1877		
6			Njord	1878			
7			Tyr	1878			
8			Hefring (TS)	1880			
9			Bulgia	1884			

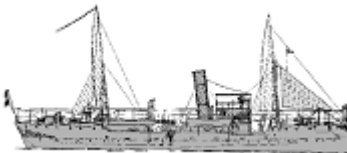
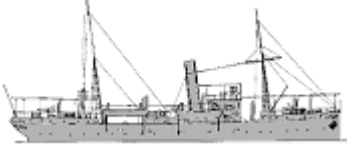
## MINE WARFARE SHIPS

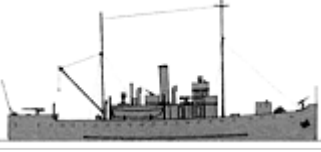
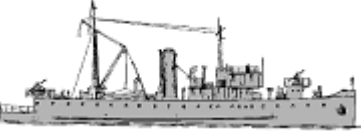
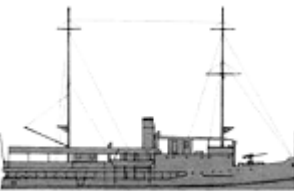
ML	Serdang	1	1	Serdang	1897		820t, 53.9x9.4x3.7m, 2vte, 1300hp, 12.9kts, 97p; 1x1-105/35, 4x1-37/23, 2x5-37/20, ~50m
	Koetei	2	2	Siboga	1898		788t, 53.7x9.4x3.7m, 2vte, 1380hp, 13.7kts, 97p; 1x1-105/35, 4x1-37/23, 2x5-37/20, ~50m
			3	Assahan	1900		
	Hydra	2	4	Das	1876		218t, 25.9x8.2x2.3m, 2b,1vce, 146hp, 8kts, 34p; 2x1-37/23, 1x5-37/20, ~20m
			5	Havik	1874		
	Wodan	4	6	Balder	1879		280t, 27.8x8.2x2.3m, 2b,1vce, 171hp, 8.3kts, 34p; 1x1-150/40(7), 2x1-37/23, 1x5-37/20, ~20m
			7	Thor	1877		
			8	Vidar	1879		
			9	Hadda	1880		
	Hydra	2	10	Hydra	1912		670t, 49.7x9.0x2.8m, 2b,2vte, 900hp, 11kts, 59p; 3x1-75/55, 2x1-12.7, 70m
			11	Medusa	1911		
	Van Meerlant	2	12	Van Meerlant	1922		748t, 54.8ppx8.7x3.2m, 2b,2vte, 1000hp, 13kts, 60p; 3x1-75/55, 2x1-12.7, 60m
			13	Douwe Aukes	1922		
	Pro Patria	1	14	Pro Patria	1923		612t, 47.0ppx8.6x2.3m, 2b,1vte, 650hp, 10kts, 61p; 1x1-75/40, 2x1-12.7, 60m

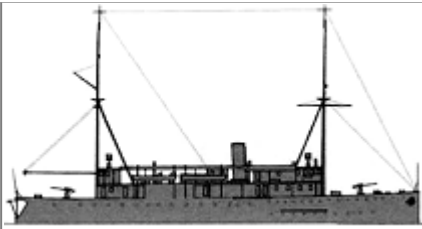

	Krakatau	1	15	Krakatau	1924		1160t, 65.0ppx10.0x3.2m, 2b,1vte, 2500hp, 15.5kts, 105p; 2x1-75/40, 4x1-12.7, 150m
AML	-	1	1	Hercules	1910		234t; 20m
MS	Nr.1	4	1	M1	1918	No picture	238(1)-205(2)-230(3,4)t, 30.5(1)-29.7(2)-29.8(3,4)x 7.0(1)-6.7(2)-6.4(3,4)x 2.8(1)-3.1(2)-2.5(3,4)m, 1b,1vte, 500(1,2)-450(3,4)hp, 9.5(1)-10(2-4)kts, 16p; 1x1-12.7, MS
			2	M2	1918		
			3	M3	1918		
			4	M4	1918		

NAVAL AVIATION (*approximately, maximal number of delivered planes signed*)

Seaplanes	R: 19 FF-33L, 41 WA
-----------	---------------------

[home](#)

[World navies yesterday](#)

[1925](#)

# NEW ZEALAND 01 January 1925

## CRUISERS

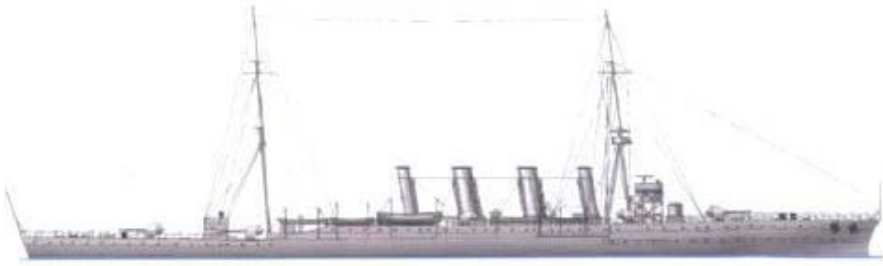
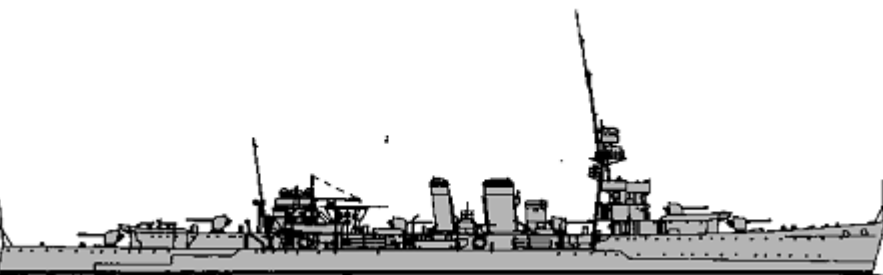
CL	Chatham	1	1	Chatham	1912		6000t, 139.6x14.9x4.9m, 12b,4t, 25000hp, 25.5kts, 475p; 51belt, 38deck, 102shields, 102CT; 8x1-152/45, 1x1-76/45, 4x1-47/40, 2-533TT
	Delhi	1	2	Dunedin	1919		5870t, 143.6x13.9x5.0m, 6b,2gt, 40000hp, 29kts, 460p; 76belt, 25deck, 25shields, 76CT; 6x1-152/45, 2x1-76/45, 2x1-40/39, 4x3-533TT

© Ivan Gogin, 2010-15

[home](#)[World navies yesterday](#)[1925](#)

## Norway 01 January 1925

### CAPITAL SHIPS

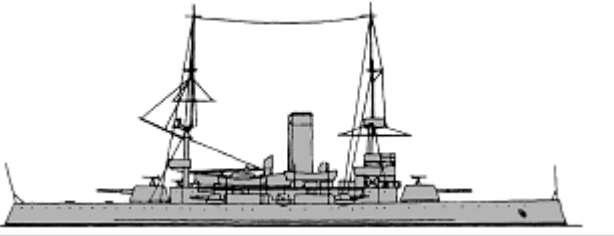
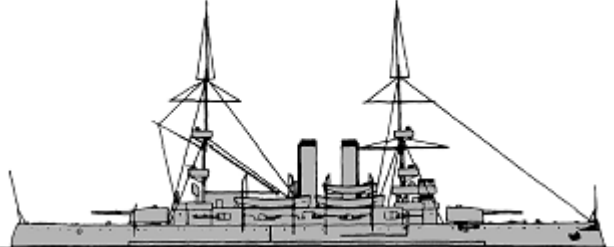



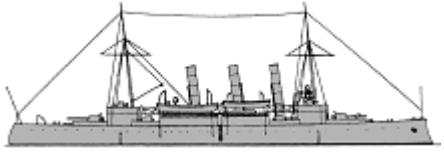



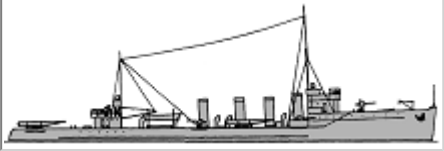

BC	Harald Haarfagre	1	Harald Haarfagre	1898		3858t, 92.7x14.8x5.4m, 3b,2vte, 4000hp, 16.9kts, 245p; h: 178belt, 51deck, 203turrets, 152CT; 2x1-209/44, 6x1-120/44, 6x1-76/40, 2x1-47/46, 6x1-37/45, 2-450TT		
		2	Tordenskjold	1898				
	Norge	3	Norge	1901				4166t, 94.6x15.4x5.4m, 6b,2vte, 4500hp, 16.5kts, 266p; 152belt, 51deck, 203turrets, 152CT; 2x1-209/44, 6x1-149/46, 8x1-76/40, 4x1-47/46, 2-450TT
		4	Eidsvold	1901				

### CRUISERS

CL	Frithjof	1	1	Frithjof (TS)	1896		1427t, 68.2x10.0x4.0m, 6b,2vte, 2800hp, 15kts, 154p; H- 32deck; 2x1-120/44, 4x1-76/40, 4x1-37/45, 1-450TT
----	----------	---	---	---------------	------	--	---

### TORPEDO SHIPS

DD	Draug	3	1	Draug	1909		578(1,2)-597(3)t, 69.2x7.3x2.9m, 4b, 2vte(1,2)-2t(3), 7500(1,2)-8000(3)hp, 26.5(1)-27(2)-27.4(3)kts, 76p; 6x1-76/40, 3x1-450TT
			2	Troll	1912		
			3	Garm	1914		
	Hval	2	1	Hval	1896		

TB		2	Delfin	1896			
	Storm	3	Storm	1898		107t, 39.9x4.8x2.2m, 2b,1vte, 1100hp, 21kts, 23p; 2x1-37/45, 2x1-450TT	
		4	Brand	1898			
		5	Trods	1898			
	Laks	6	Laks	1900		107t, 38.5x4.8x2.2m, 2b,1vte, 1150hp, 21kts, 23p; 2x1-37/45, 2x1-450TT	
		7	Sild	1900			
		8	Sæl	1901			
		9	Skrei	1901			
	Trygg	10	Trygg	1920		256t, 53.0x5.5x2.0m, 2b,2vte, 3500hp, 25(10,11)-24(12)kts, 33p; 2x1-76/28, 2x2-450TT, 10m	
		11	Snøgg	1921			
		12	Stegg	1923			
	Lyn	2	13, 14	Lyn, Blink	1896		64t, 34.5x3.8x1.8m, 2b,1vte, 650hp, 19kts, 21p; 1x1-37/45, (1+1x1)-450TT
	Djerv	3	15-17	Djerv, Kvikk, Dristig	1897-1898		66t, 34.5x3.8x1.7m, 2b,1vte, 650hp, 19kts, 21p; 2x1-37/45, (1+1x1)-450TT
	Hvass	2	18, 19	Hvass, Kjæk	1901		74t, 34.1x4.4x1.6m, 2b,2vte, 650hp, 19kts, 16p; 2x1-37/45, (1+1x1)-450TT
	Hauk	2	20, 21	Hauk, Falk	1904		73t, 34.9x4.4x1.6m, 2b,2vte, 750hp, 20kts, 16p; 2x1-37/45, (1+1x1)-450TT
	Ørn	2	22, 23	Ørn, Ravn	1905		73t, 34.5x4.4x1.6m, 2b,1vte, 850hp, 23kts, 16p; 2x1-37/45, (1+1x1)-450TT
	Grib	3	24-26	Grib, Jo, Lom	1906		74t, 36.2x4.5x1.9m, 2b,1vte, 1000hp, 23kts, 16p; 2x1-37/45, (1+1x1)-450TT
	Teist		27	Teist	1908		103(27,28)-108(29)t, 41.1x4.7x2.3(27,28)-2.4(29)m, 2b,1vte, 1700hp, 25kts, 21p; 1x1-76/28(29), 2x1-47/46(27,28), (1+2x1)-450TT(27,28), (1+1x1)-450TT(29)
			28	Skarv	1908		
		29	Kjell	1913			





## SUBMARINES

SS	Kobben	1	1	A1	1909	No picture	206/259t, 39.3x3.7x3.0m, 2d/em, 440/250hp, 11.9/8.9kts, 14p, 30m; 3-450TT
	A2	3	2	A2	1914		268/342t, 46.5x4.8x2.7m, 2d/em, 700/380hp, 14.5/9kts, 17p, 50m; 3-450TT
			3	A3	1914		
			4	A4	1914		
	B1	2	5	B1	1923		420/545t, 51.0x5.3x3.5m, 2d/em, 900/700hp, 14.5/10.5kts, 23p, 60m; 1x1-76/28, 4-450TT
			6	B2	1924		

## OTHER FIGHTING SHIPS

PG	Ellida	1	1	Ellida	1882	No picture	1045t, 58.0x9.9x4.4m, vte, 10.5kts, 130p; 2x1-76/40, 1x1-75/55, 2x1-65/55, 2x1-37/45
	Æger	1	2	Æger	1894		413t, 33.2x8.8x2.4m, 2b,2vte, 350hp, 9kts, 43p; 38deck; 1x1-209/35, 1x1-75/55, 2x1-47/50

## MINE WARFARE SHIPS

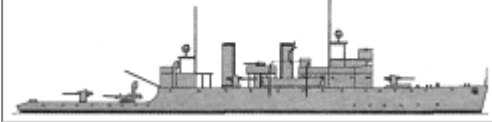
ML	Vale	2	1	Vale	1874		250t, 27.3x7.9x2.2m, 2b,2vte, 200hp, 8kts, 38p; 1x1-120/44, 1x1-37/45, 2x5-37/21, 50m
			2	Uller	1877		
	Brage	2	3	Brage	1879		270t, 28.9x7.9x2.2m, 2b,2vte, 220hp, 8.5kts, 38p; 1x1-149/46, 1x1-47/46, 2x5-37/21, 1-356TT(4), 50m
			4	Nor	1879		
	Vidar	1	5	Vidar	1882		270t, 28.9x7.9x2.2m, 2b,2vte, 330hp, 9.5kts, 38p; 1x1-149/46, 1x1-47/46, 2x5-37/21, 50m
	Gor	2	6	Gor	1885		290(6)-278(7)t, 31.3xx2.2m, 2b,2vte, 420hp, 10.5kts; 1x1-120/44, 1x1-76/28(6), 1x1-47/50(7), 2x5-37/21, 1-356TT, 55m
			7	Tyr	1887		
Frøya	1	8	Frøya	1917		755t, 75.6x8.2x2.8m, 2b,2vte, 7000hp, 21.8kts, 78p; 4x1-102/40, 1x2-450TT, 180m	
Glommen	2	9	Glommen	1917	No picture	380t, 42.0x8.5x2.1m, 1b,1vte, 170hp, 9.8kts, 35p; 2x1-76/28, 120m	
		10	Laugen	1918			

[home](#)

[World navies yesterday](#)

[1925](#)

## Paraguay 01 January 1925

### ESCORTS

APC	-	2	1	Capitán Cabral	1907	206t; 1x1-76/40
			2	Tacuari	1910	150t; 2x1-76/50, 2x1-76/40

© Ivan Gogin, 2011-15

[home](#)[World navies yesterday](#)[1925](#)

## Persia 01 January 1925

### OTHER FIGHTING SHIPS

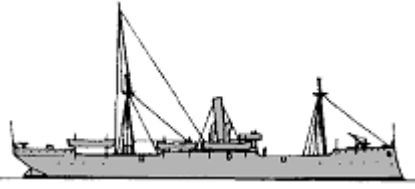
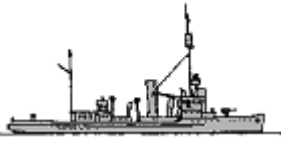
PG	Persepolis	1	1	Persepolis	1885		1200t, 63.1x10.0x5.9m, 1vte, 450hp, 10kts; 1x1-102/40, 2x1-87/25, 2x1-37/32
	Muzaffer	1	2	Muzaffer	1899	No picture	379t, 41.1x7.9x4.0m
	Fathiya	1	3	Fathiya	1919		193t, 43.0x6.0x1.4m, 1b,2vte, 600hp, 14kts, 35p; 1x1-76/40

© Ivan Gogin, 2011-15

[home](#)[World navies yesterday](#)[1925](#)

## Peru 01 January 1925

### CRUISERS

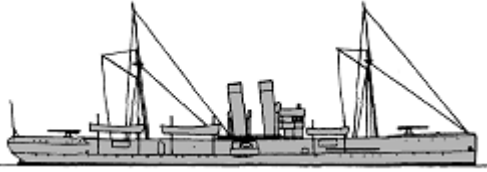
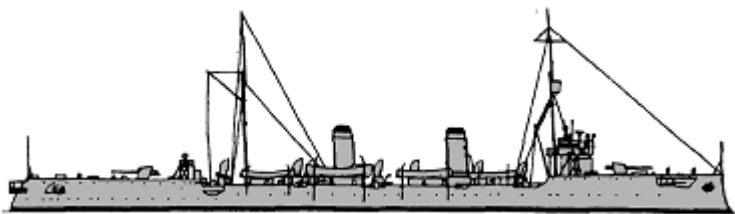
	Lima	1	1	Lima	1888		1790t, 76.2x10.7x4.6m, 4b,2hc, 1800hp, 16.2kts, 150p; 4x1-102/50, 3x1-47/40
CL	Almirante Grau	2	3	Almirante Grau	1907		4877t, 115.8x12.3x4.3m, 10b,2vte, 14000hp, 24kts, 320p; 38belt, 38deck, 76shields, 76CT; 2x1-152/50, 8x1-76/40, 6x1-57/40, 2x1-37/23, 2-450TT
				Coronel Bolgnesi	1907		

### TORPEDO SHIPS

DD	Teniente Rodríguez	1	1	Teniente Rodríguez	1911		520t, 64.6ppx6.5x3.1m, 4b,3t, 8600hp, 28kts, 79p; 6x1-65/50, (1+2x1)-450TT
----	--------------------	---	---	--------------------	------	--	--

### OTHER FIGHTING SHIPS

PGR	Iquitos	1	1	Iquitos	1875	No picture	50t, 23.4x3.7x1.2m, 7.5kts; 1x1-47/40
	América	1	2	América	1904	No picture	240t, 40.5x5.9x1.4m, 2b,2vte, 350hp, 14kts, 26p; 4x1-47/40
	Napo	1	3	Napo	1920	No picture	98t, 30.9x5.5x0.9m, 1b,1vte, 250hp, 12kts, 22p; 4x1-47/40, 2x1-37/23





© Ivan Gogin, 2012-15

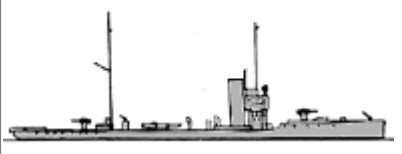

[home](#)[World navies yesterday](#)[1925](#)

## POLAND 01 January 1925

### TORPEDO SHIPS

TB	Ślązak	4	1	Ślązak	1917		381(1,2,4)-392(3)t, 61.1(1,2)-60.0(3)-60.4(4) x6.4x2.2(1,2)-2.3(3)-2.1(4)m, 2b,2t, 6000(1-3)-5700(4)hp, 28(1-3)-26(4)kts, 50(1-3)-55(4)p; 2x1-75/34, 2x1-450TT
			2	Krakowiak	1918		
			3	Kujawiak	1917		
			4	Góral	1917		
	Mazur	2	5	Mazur	1915		421t, 62.6x6.2x2.5m, 4b,2t, 5500hp, 28kts, 60p; 2x1-75/34, 2x1-450TT
			6	Kaszub	1915		

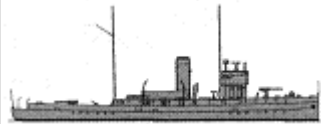
### OTHER FIGHTING SHIPS

PG	Generał Haller	2	1	Generał Haller	1921		441t, 50.1x6.8x2.3m, 2b,2vte, 1150hp, 15kts, 49p; 6x1-47/43
			2	komendant Piłsudski	1921		
RMON	Warszawa	4	1	Horodyszcze	1920		126t, 34.7x5.1x0.8m, 3d, 180hp, 10kts, 49p; 6belt, 10deck, 10turrets; 2x1-105/45
			2	Pińsk	1920		
			3	Toruń	1920		
			4	Warszawa	1920		

### MINE WARFARE SHIPS

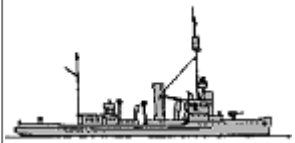
MS	Czajka	4	1	Czajka	1918		193t, 43.0x6.0x1.4m, 1b,2vte, 600hp, 14kts, 35p; 1x1-47/43, 20m, MS
			2	Jaskółka	1918		
			3	Mewa	1918		
			4	Rybitwa	1918		

© Ivan Gogin, 2011-15

[home](#)[World navies yesterday](#)[1925](#)

## PORTUGAL 01 January 1925

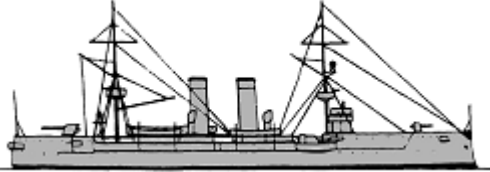

### CAPITAL SHIPS

BC	Vasco da Gama	1	1	Vasco da Gama	1876		3200t, 70.9ppx12.2x6.3m, 4b,2vte, 6000hp, 15.5kts, 260p; steel: 250belt, 75deck, 200shields; 1x1-203/40, 1x1-152/45, 1x1-102/40, 6x1-47/40
----	---------------	---	---	---------------	------	--	--

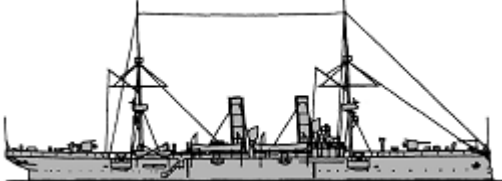
### CRUISERS

CL	Adamastor	1	1	Adamastor	1897		1757t, 74.0ppx10.7x4.7m, 4b,2vte, 4000hp, 18kts, 237p; 30deck, 65CT; 2x1-120/40, 4x1-105/40, 4x1-67/40, 2x1-37/20, 3-356TT
----	-----------	---	---	-----------	------	--	--

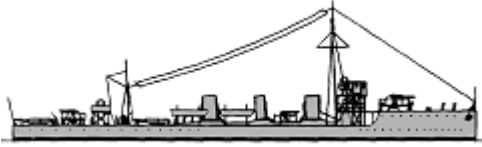
### TORPEDO SHIPS



DD	Tejo	1	1	Tejo	1901		522t, 70.0x7.0x2.5m, 4b,2vte, 7000hp, 25kts, 85p; 1x1-100/41, 1x1-76/40, 2x1-47/40, 2x1-356TT
	Guadiana	4	2	Douro	1913		660t, 73.2x7.2x2.3m, 3b,2t, 11000hp, 27kts, 80p; 1x1-100/41, 2x1-76/40, 2x2-450TT
3			Guadiana	1914			
4			Vouga	1920			
5			Tâmega	1923			
TB	Nº2	1	1	Nº2	1886		65t, 36.5ppx3.9x1.0m, 1b,1vc, 700hp, 19kts, 85p; 2x5-37/20, 2-356TT
	82F	4	2	Ave	1916		330t, 58.8x5.8x1.5m, 2b,2t, 5000hp, 28kts, 38p; 1x1-66/30, 1x1-57/40, 2x2-450TT
			3	Sado	1916		

		4	Liz	1916		
		5	Mondego	1916		

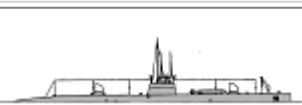

## SUBMARINES

SS	Espadarte	1	1	Espadarte	1913	No picture	245/300t, 45.1x4.2x2.9m, 2d/em, 550/300hp, 13.8/8kts, 21p; 2-450TT
	Foca	3	2	Foca	1917		262/382t, 45.6x4.2x3.1m, 2d/em, 550/400hp, 14.2/8.2kts, 21p, 40m; 2-450TT
			3	Golginho	1917		
			4	Hidra	1917		

## ESCORTS

SL	República	1	1	República	1915		1350t, 81.7x10.2x3.4m, 2b,1vte, 2000hp, 16kts, 137p; 2x1-102/40, 2x1-76/40, 4x1-47/40
	Carvalho Araujo	1	2	Carvalho Araujo	1915		1275t, 80.0x10.1x3.4m, 2b,1vte, 1800hp, 16.5kts, 137p; 2x1-102/40, 2x1-76/40, 4x1-47/40, 2DCT
PC	Dili	1	1	Dili	1910s	No picture	495t, 42.7ppx7.6x3.1m, 1vce, 500hp, 11kts, 72p
	Lince	1	2	Lince	1911	No picture	77t, 27.0ppx4.3x1.8m, 2sd, 300hp, 12kts, 20p

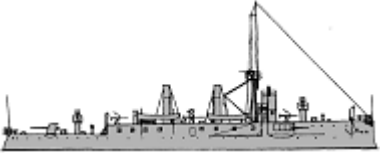
## OTHER FIGHTING SHIPS

PG	Limpopo	1	1	Limpopo	1890	No picture	288t, 37.8x6.4x2.0m, 1b,1vc, 520hp, 11.3kts, 54p; 3x1-57/40
	Pátria	1	2	Pátria	1905		626t, 60.0ppx8.3x2.5m, 4b,2vte, 1800hp, 16.7kts, 95p; 12deck; 4x1-100/41, 6x1-47/40
			3	Lúrio	1907		
	4	Save	1908		305t, 42.8x7.2x1.8m, 2b,2vte, 500hp, 12.5kts, 51p; 2x1-47/40		
	Beira	5	5	Beira	1910		492t, 45.0x8.3x2.1m, 2b,2vte, 700hp, 13kts, 51p; 1x1-87/17(5,8), 1x1-76/40(6,7), 2x1-76/40(9), 1x1-65/50(5), 2x1-57/40(6,7), 2x1-47/40(5-7), 4x1-47/40(8)
			6	Ibo	1911		
			7	Mandovi	1917		
			8	Bengo	1917		
	9	Quanza	1917				
APG	-	-	1	Açor	1874		330t

PR	Rio Minho	1	1	Rio Minho	1904	No picture	38t, 24.6x4.0x0.6m, 1b,vte(sw), 64hp, 7.5kts, 8p; 1x1-37/20
	Flecha	1	2	Flecha	1909	No picture	44t, 21.0x4.0x0.7m, 1b,vte(sw), 45hp, 10kts, 7p; 1x1-37/20
	Macau	1	3	Macau	1910		133t, 36.5x6.0x0.7m, 1b,1vte, 250hp, 11.8kts, 24p; 2x1-57/40
	Téte	1	4	Téte	1920	No picture	130t, 23.4x6.1x0.7m, 1b,1vt2(sw), 70hp, 8kts, 20p; 2x1-47/40

## COASTAL FORCES

YP	N°2	2	1, 2	N°2, 3	1918		37t, 24.4x3.7x1.2m, 2pe, 440hp, 19kts, 8p; 1x1-47/40, 2DCR, MS
----	-----	---	------	--------	------	---	--

## MINE WARFARE SHIPS





ML	Vulcano	1	1	Vulcano	1910		151t, 33.5x5.9x1.3m, 1b,2vte, 412hp, 12kts, 24p; 50m
----	---------	---	---	---------	------	--	--

© Ivan Gogin, 2011-14

[home](#)[World navies yesterday](#)[1925](#)

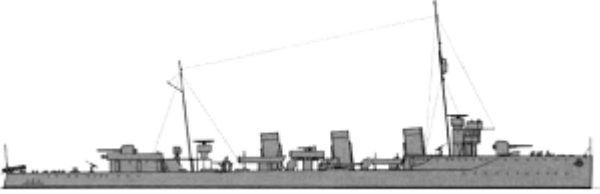
# Romania 01 January 1925

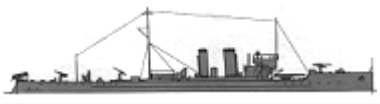
## TORPEDO SHIPS



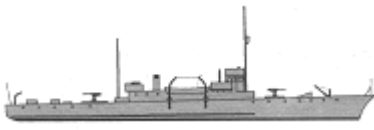

DD	Mărăști	1	Mărăști	1917		1723t, 94.7x9.5x3.5m, 5b,2t, 45000hp, 34kts, 139p; (2x2+1x1)-120/45, 2x1-76/40, 2x2-450TT, 50m
		2	Mărășești	1918		
TB	Viforul	1	Viforul	1914		320t, 58.2x5.7x1.5m, 2b,2t, 5000hp, 28kts, 41p; 2x1-66/30, 2x2-450TT
		2	Vartejul	1914		
		3	Vijelia	1914		
		4	Sborul	1914		
	Naluca	5	Naluca	1916		330t, 58.8x5.8x1.5m, 2b,2t, 5000hp, 28kts, 41p; 2x1-66/30, 2x2-450TT
		6	Smeul	1916		
TBR	Căpitan Nicolae Lascăr Bogdan	7	Major Ene Constantin, Căpitan Nicolae Lascăr Bogdan, Căpitan Romani Michail, Major Giurascu Dimitrie, Major Sontu Gheorge, Major Grigore Ioan, Locotenent Calinescu Dimitrie	1906 - 1907		51t, 30.4x4.0x0.8m, 2b,2vce, 550hp, 18kts, 20p; 1x1-47/44, 2spar torpedoes

## ESCORTS

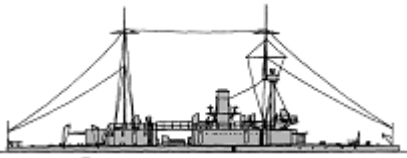
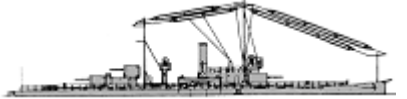

FS	Căpitan Dumitrescu	1	Căpitan Dumitrescu	1917		443t, 60.2x7.0x2.6m, 2d, 900hp, 14.5kts, 50p; 2x1-100/45, 2DCT
		2	Locotenent-Comandor Stihl Eugen	1917		
		3	Locotenent Lepri Remus	1918		
		4	Sublocotenent Ghiculescu	1918		

## OTHER FIGHTING SHIPS

		1	Ion C. Brătianu	1907		
		2	Lascar Catargiu	1907		

MONR	Ion C. Brătianu	4	3	Alexandru Lachovari	1908		750t, 62.0-63.5x10.5x1.8m, 2b,2vte, 1800hp, 13kts, 110p; 70belt, 70deck, 75turrets, 75CT; 3x1-120/35, 2x1-120/10, 4x1-47/44
			4	Mihail Kogălniceanu	1907		
	Ardeal	1	5	Ardeal	1905		650t, 60.3x9.5x1.6m, 2b,2vte, 1400hp, 13kts, 89p; 40belt, 25deck, 75turrets, 40CT; 2x1-120/35, 2x1-90/45
	Bucovina	1	6	Bucovina	1915		~700t, 62.2x10.3x1.3m, 2b,2vte, 1750hp, 13.5kts, 91p; 40belt, 25deck, 50turrets, 50CT; 1x2-120/40, 2x1-120/10, 2x1-66/50, 2x1-47/44
Basarabia	1	7	Basarabia	1915		770t, 62.0x10.5x1.8m, 2b,2vte, 1600hp, 12.2kts, 133p; 40belt, 35deck, 50turrets, 40CT; 1x2-120/40, 3x1-120/10, 2x1-66/50	
FBR	MR491	6	1	MR491	1916		255t, 54.7x7.1x1.2m, 2sd, 100hp, 5.5kts; 1x1-152/45(4-6), 2x1-120/45(1-3)
			2	MR492	1916		
			3	MR493	1916		
			4	MR494	1916		
			5	MR495	1916		
			6	MR496	1916		

## COASTAL FORCES



PS	M1	2	1, 2	M1, 2	1918		44t, 24.4x3.7x1.2m, 2pe, 460hp, 17kts, 15p; 1x1-76/40, 2DCR
	M3	5	3-5	M3-7	1920		45t, 24.4x3.7x1.3m, 2pe, 460hp, 19kts, 15p; 1x1-76/40, 2DCR



[home](#)[World navies yesterday](#)[1925](#)

# Siam 01 January 1925

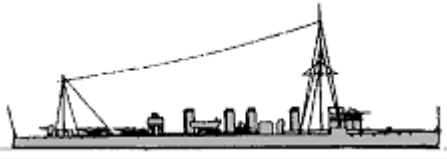
## TORPEDO SHIPS

DD	Sua Tayanchon	1	Sua Tayanchon	1908		385t, 69.2ppx6.6x1.8m, 4b,2vte, 6000hp, 27kts, 75p; 1x1-76/40, 5x1-57/40, 2x1-450TT
		2	Sua Khamronsin	1912		
	Phra Ruang	1	Phra Ruang	1917		1208t, 83.6x8.3x2.7m, 3b,2gt, 27000hp, 36kts, 82p; 3x1-102/40, 1x1-76/40, 1x1-40/39, 2x2-533TT
TB	No1	1	No1	1908		100t, 41.1x4.9x2.1m, 2b,1vte, 1200hp, 23kts, 29p; 1x1-57/40, 1x1-47/43, 2x1-450TT
		2	No2	1908		
		3	No3	1908		
		4	No4	1913		

## ESCORTS

SL	Chow Phraya	1	Chow Phraya	1919		840t, 70.4x8.7x2.2m, 2b,2vte, 2200hp, 16kts, 65p; 1x1-102/40, 1x1-76/40
----	-------------	---	-------------	------	--	---

## OTHER FIGHTING SHIPS

	Mongkut Rajakumarn	1	Mongkut Rajakumarn	1887	No picture	700t, 53.3x7.2x3.4m, 2b,2vte, 800hp, 14kts, 100p; 2x1-120/40, 4x1-57/40, 3x1-37/23, 1-356TT
PG	Muratha	2	Muratha	1898		530(2)-580(3,4)t, 44.2(2)-49.4(3,4)x7.0x3.1m, 2b,2vte, 500hp, 11.4kts, 83p; 1x1-120/40, 5x1-57/40, 4x1-37/23
		3	Bali	1900		
		4	Sugrib	1901		

	Sri Monthon	1	5	Sri Monthon	1908		225t, 41.8x5.5x2.0m, 1b,2vte, 750hp, 14.5kts, 34p; 2x1-57/40
DV	Prap Porapak	1	1	Prap Porapak	1898	No picture	210t

## COASTAL FORCES

PT	No1	5	1-5	No1-5	1922		14t, 16.8x3.4x1.1m, 2pe, 750hp, 37kts, 5p; 2-450TT
----	-----	---	-----	-------	------	---	--

© Ivan Gogin, 2011-15

[home](#)

[World navies yesterday](#)

[1925](#)

## SOUTH AFRICA 01 January 1925

### MINE WARFARE

TR	Mersey	2	1	Sonneblom	1918		665t, 45.1x7.2x2.8m, 1b, 1vte, 600hp, 11kts, ?p; 1x1-76/40, MS
			2	Immortelle	1918		

© Ivan Gogin, 2010-15

[home](#)[World navies yesterday](#)[1925](#)

## SOVIET UNION 01 January 1925

*IN SERVICE: 1 battleship-predreadnought, 3 battleships, 2 protected cruisers, 32 destroyers, 5 torpedo boats, 19 submarines, 7 gunboats, 1 auxiliary gunboat, 5 dispatch vessels, 15 auxiliary dispatch vessels, 6 river gunboats, 1 armed river steamer, 13 motor torpedo boats, 31 patrol motor launches, 17 armoured river motor gunboats, 4 minelayers, 2 auxiliary minelayers, 2 netlayers, 18 minesweepers, 17 auxiliary minesweepers, 1 auxiliary river minesweeper, 1 minesweeping boat, 5 Board Guard ships, 2 auxiliary Board Guard ships*

### CAPITAL SHIPS

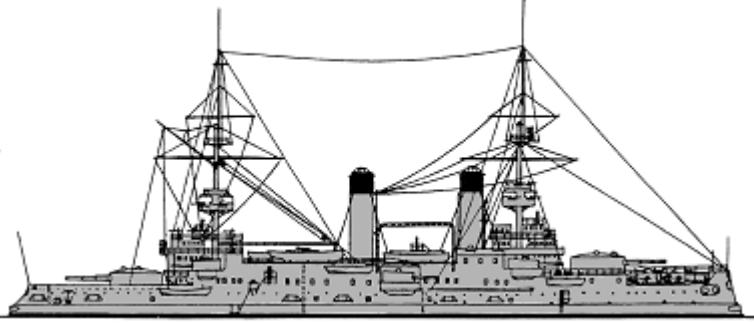
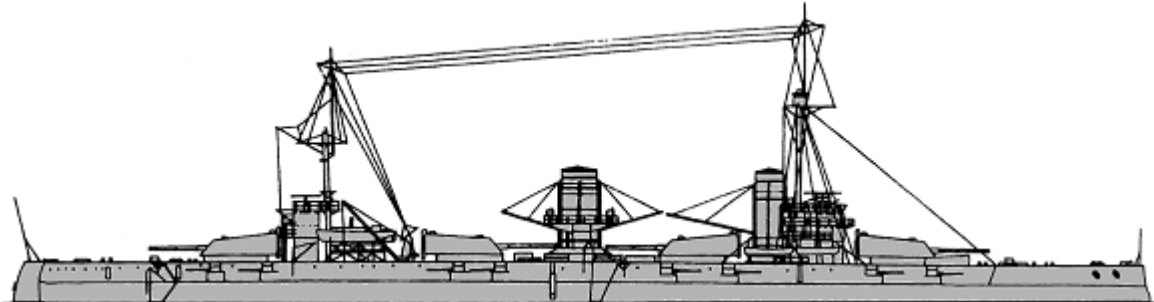

BB	Tsesarevich	1	1	Grazhdanin	1903		13110t, 118.5x23.3x7.9m, 20b,2vte, 16300hp, 18kts, 779p; 250belt, 50deck, 250turrets, 254CT; 2x2-305/40, 6x2-152/45, 10x1-75/50, 4x1-47/43, 2x1-37/30, 4-381TT
	Sevastopol	2		Gangut	1914		26900t, 181.2x26.9x8.4m, 25b,4t, 42000hp, 23kts, 1140p; 225belt, 75deck, 305turrets, 250CT; 4x3-305/52, 16x1-120/50, 6x1-76/30, 4-450TT
3			Parizhskaya Kommuna	1914			
4			Marat	1915			



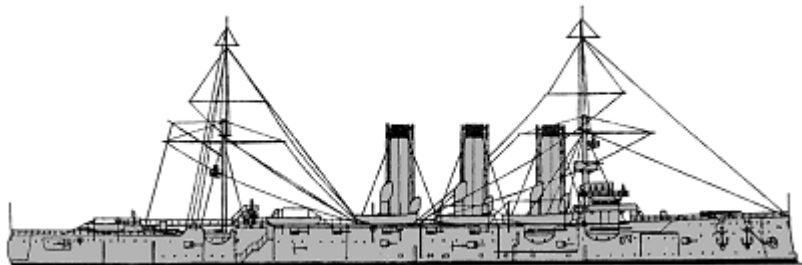
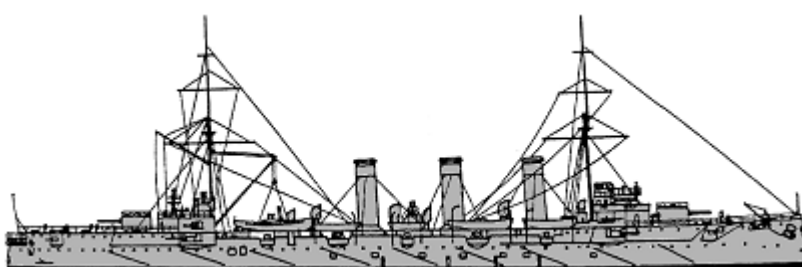

### CRUISERS

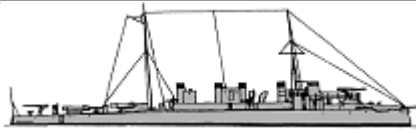
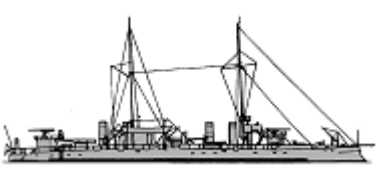
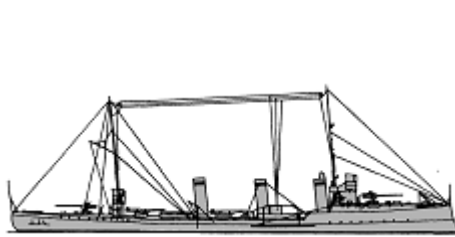
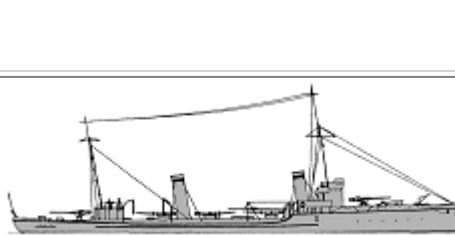
	Pallada	1	1	Avrora	1903		6897t, 126.8x16.8x6.4m, 24b,3vte, 11610hp, 19.2kts, 570p; nickel steel: 38/63deck, 25shields, 152CT; 10x1-130/55, 4x1-76/30, 126m
--	---------	---	---	--------	------	--	---

CL						
Bogatyr	1	2	Komintern	1905		7790t, 134.0x16.6x6.3m, 16b,2vte, 19500hp, 23kts, 581p; 35/70deck, 127turrets, 80casemates, 140CT; 16x1-130/55, 2x1-47/43, 2-450TT, 290m

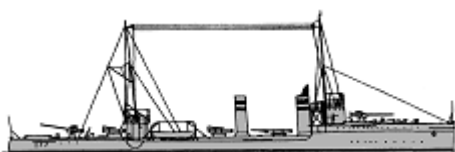

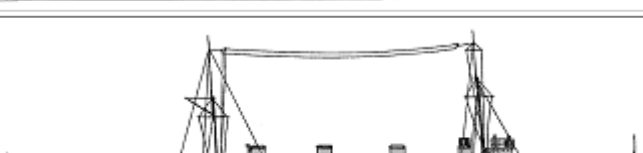
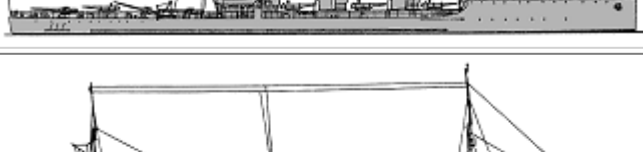
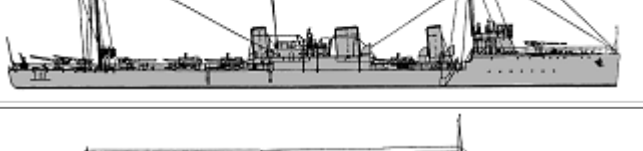
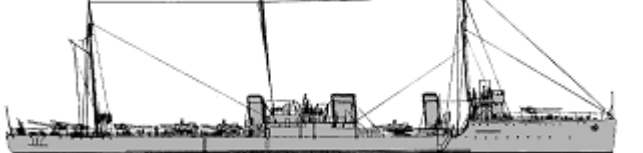
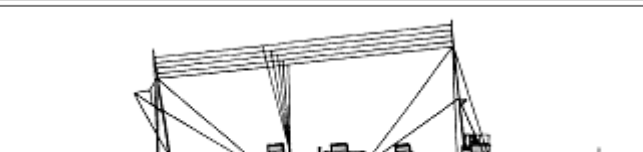



## TORPEDO SHIPS

Boykiy	1	1	Anisimov	1902		530t, 64.0x6.4x2.5m, 4b,2vte, 5700hp, 26kts, 69p; 2x1-75/50, 2x1-450TT, 18m
Leytenant Burakov	2	2	Moshchny	1905		492t, 56.5x6.4x3.5m, 4b,2vte, 5700hp, 27kts, 67p; 2x1-75/50, 2x1-450TT, 10m
	3	Lovkiy	1906			
Ukrayna	7	4	Bakinskiy Rabochiy	1905		880t, 73.2x7.2x3.4m, 4b,2vte, 7000hp, 26kts, 88p; 3x1-102/60, 1x1-40/39(4-7,9), 1x1-37/23, 2x1-450TT, 16m
		5	Markin	1905		
		6	Altfater	1905		
		7	Steregushchiy	1906		
		8	Strashny	1906		
		9	Donskoy Kazak	1906		
		10	Zabaykalets	1907		
Emir Bukharskiy	2	11	Yakov Sverdlov	1905		720t, 71.9x7.2x2.7m, 4b,2vte, 6500hp, 25kts, 99p; 2x1-102/60, 1x1-40/39, 20m
		12	Karl Libknekht	1906		
Inzhener-Mekhanik Dmitriev	1	13	Burny	1906		540t, 63.6x7.0x2.7m, 4b,2vte, 6000hp, 27kts, 65p; 2x1-75/50, 3x1-450TT, 16m
		14	Sladkov	1906		
		15	Gaydamak	1906		

DD	Vsadnik	4					930t, 71.9x7.2x2.4m, 4b,2vte, 6500hp, 25kts, 99p; 2x1-102/60, 1x1-37/23, 3x1-450TT, 25m
		16	Zheleznyakov	1907			
		17	Roshal	1907			
	General Kondratenko	1	18	Sibirskiy Strelok	1906		840t, 75.2x8.2x2.4m, 4b,2vte, 7300hp, 25.5kts, 102p; 3x1-102/60, 3x1-450TT, 25m
			Storozhevoy	19	Storozhevoy	1907	
	20	Rastoropny		1908			
	21	Deyatelny		1907			
	22	Dostoyny		1907			
	Novik	1	23	Novik	1913		1595t, 102.4x9.5x3.5m, 6b,3t, 35100hp, 36kts, 113p; 4x1-102/60, 4x2-450TT, 80m
	Pobeditel	5	24	Volodarskiy	1915		1450t, 98.0x9.3x3.2m, 4b,2t, 30000hp, 35kts, 112p; 4x1-102/60, 1x1-76/30(24,25), 1x1-40/39(26-28), 3x3-450TT, 2DCR(24), 58m(24), 80m(25-28)
25			Uritskiy	1915			
26			Engels	1916			
27			Zinovyev	1916			
28			Stalin	1916			
Kapitan Izylmetyev	2	29	Lenin	1916		1450t, 98.0x9.3x3.9m, 4b,2t, 31500hp, 34kts, 150p; 4x1-102/60, 1x1-76/30(30), 1x1-40/39(29), 3x3-450TT, 50m	
		30	Trotsky	1916			
Fidonisi	1	31	Nezamozhny	1923		1760t, 92.5x9.1x3.8m, 5b,2t, 29000hp, 33kts, 136p; 4x1-102/60, 2x1-76/30, 4x3-450TT, 2DCR, 60m	
Izyaslav	1	32	Karl Marx	1917		1570t, 107.0x9.5x4.1m, 5b,2t, 32700hp, 35kts, 150p; 5x1-102/60, 1x1-76/30, 3x3-450TT, 80m	
Krechet	3	1	Porazhayushchiy	1902		305t, 57.9(1)-58.1(2,3)x5.7x2.3m, 8b(1)-4b(2,3),2vte, 3800hp, 27kts, 58p; 2x1-75/50, 2x1-450TT, 10m	
		2	Marti	1902			
		3	Leytenant	1902			



TB			Shmidt			
		4	Potapenko	1906		385t, 58.4x5.6x2.2m, 4b,2vte, 3800hp, 26kts, 60p; 2x1-75/50, 2x1-450TT, 10m
Tochny	2	5	Lazo	1907		

## SUBMARINES

Kasatka	3	1	Kasatka	1905		140/177t, 33.5x3.7x3.3m, 1d/em, 120/100hp, 9/5kts, 24p, 50m; 4-450TT
		2	Makrel	1908		
		3	Okun	1908		
Minoga	1	4	Minoga	1909		123/144t, 32.6x2.8x2.7m, 2d/1e(1), 240/70hp, 10.5/5kts, 22p, 30m; 1x1-37/23, 2-450TT
Morzh	1	5	Politruk	1915		642/773t, 67.4x4.4x4.0m, 2d/em, 500/800hp, 10.8/8kts, 47p, 50m; 1x1-57/40, 1x1-47/43, 12-450TT
SS Bars	9	6	Vepr	1915		670/810t, 68.0x4.5x4.3m, 2d/em, 500/900(6-11,13,14)-2640/900(12)hp, 12/8(6-11,13,14)-17/8.7(12)kts, 44p, 50m; 1x1-75/50(6,7,10,13,14), 2x1-75/50(8,9), 1x1-63/38(6,7,10-14), 1x1-37/30, 4-450TT(6), 12-450TT(7-14)
		7	Kommunar	1916		
		8	Batrak	1916		
		9	Komissar	1916		
		10	Bolshevik	1916		
		11	Krasnoarmeets	1917		
		12	Proletariy	1917		
		13	Tovarishch	1917		
14	Krasnoflotets	1917				
Yorsh	1	15	Rabochiy	1917		655/750t, 68.0x4.5x4.3m, 2d/em, 840/900hp, 10.7/7.5kts, 44p, 50m; 1x1-63/38, 2-450TT, 42m
AG	4	16	Shakhtyor	1920		355/434t, 46.0x4.9x3.8m, 2d/em, 960/640hp, 13/10.5kts, 24p, 50m; 4-450TT
		17	Kommunist	1921		
		18	Marxist	1922		
		19	Politrabotnik	1923		

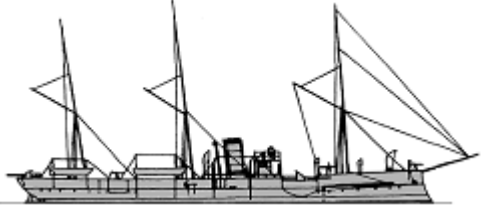
## OTHER FIGHTING SHIPS

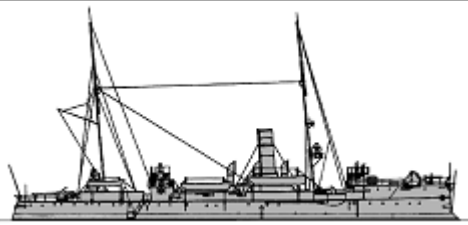
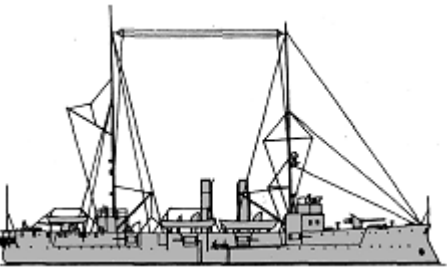
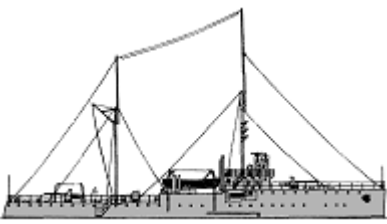
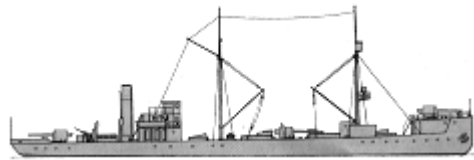
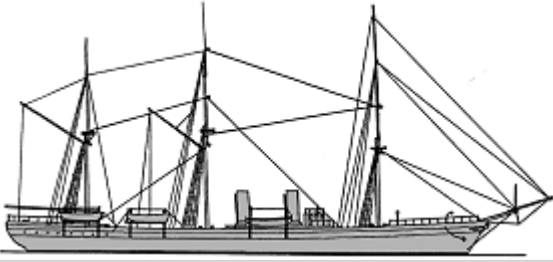

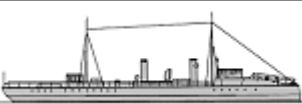
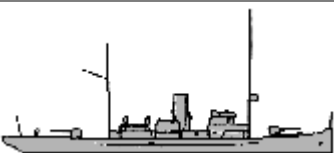

Kubanets	1	1	Znamya Sotsializma	1887		1505t, 67.2x12.2x3.6m, 6b,2hc, 1500hp, 14kts, 180p; 3x1-130/55, 2x1-76/30, 2x1-47/43, 2-381TT
Khrabry	1	2	Krasnoye Znamya	1897		2100t, 72.3x12.7x3.4m, 8b,2vte, 2100hp, 14kts, 188p; Harvey steel: 127belt, 38deck, 38shields, 25CT; 5x1-130/55, 11x1-47/43, 1-450TT, 20m

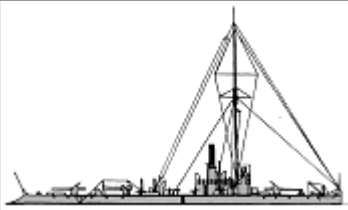
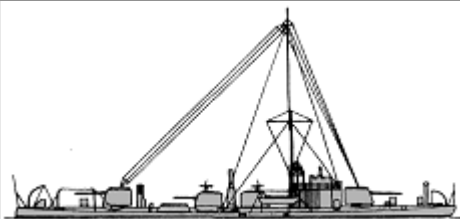

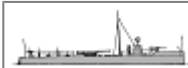

							
PG	Khivinets	1	3	Krasnaya Zvezda	1906		1360t, 70.5x11.3x3.3m, 8b,2vte, 1400hp, 13.5kts, 161p; steel: 45CT; 4x1-130/55, 2x1-47/43
	Kars	2	4	Lenin	1910		635t, 61.6x8.5x2.6m, 2d, 1000hp, 14kts, 128p; 2x1-102/60, 1x1-76/30, 4x1-75/50, 1x1-37/23
			5	Trotsky	1910		
	Elpidifor	2	6	Krasnaya Abkhaziya	1920		1300t, 74.7x10.4x1.8m, 2b,2vte, 750hp, 8.5kts, 169p; 3x1-130/55, 2x1-76/30, 180m, MS; 2000troops or 6 light tanks
			7	Krasny Adzharistan	1921		
APG	-	1	1	No2	1920		170t; 2x1-76/30
	Vityaz	1	1	Osvoboditel	1886		3537t, 79.4x13.7x5.3m, 10b,1hc, 3000hp, 11.5kts, 396p; steel: 38deck; 4x1-75/50, 4x1-47/43
DV	Kazarskiy	1	2	Kazarskiy	1890		432t, 60.2x7.4x3.3m, 2b,1vte, 21kts, 65p; 3x1-75/50
	Abo	1	3	Ilim	1886		76t, 38.5x4.5x1.9m, 1b,1vc, 640hp, 20kts, 21p; 2x1-57/50
	Lastochka	1	4	Lastochka	1905		140t, 46.5x4.7x1.5m, 2b,2t+1vte, 2250hp, 26.4kts, 23p; 2x1-47/43, 3x1-381TT
	Kopchik	1	5	Korshun	1916		550t, 51.2x7.3x2.9m, 3b,2vte, 1500hp, 15kts, 57p; 2x1-105/45, 1x1-40/39, 70m

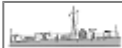
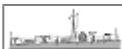



ADV	-	15	1	Krechet	1889		2844t, 85.8x11.6x3.7m, 3600hp, 13.5kts
			2	Polyarnaya Zvezda	1891		3949t; 106.5x13.8x5.2m, 6000hp, 17kts; 4x1-47/43
			3	Shtandard	1896		5557t, 112.8x15.4x6.6m, 12000hp, 20kts; 8x1-47/43
			4	Krasny Moryak	1866		1162t, 66.1x8.0x2.4m, 1000hp, 14kts
			5	Izhora	1913		210t
			6	Inzhener	1890		240t
			7	Kopanets	1913		180t
			8	Minyor	1914		150t
			9	Nevka	1905		140t
			10	Strela	1891		290t
			11	Tosmar	1900		212t
			12	Posylny			103t
			13	Krasny Adzharets	1900		100t
			14	Gryzoza	1896		350t
						15	Krasny Vympel
PGR	Vogul	2	1	Bednota	1909		349t, 54.5x8.2x1.2m, 2b,2vte, 480hp, 10.5kts, 63p; 13belt, 9deck, 13CT; 2x1-120/45, 1x1-76/30
			2	Krasnoye Znamya	1909		
	Tayfun	4	3	Tayfun	1910		1000t, 70.9x12.8x1.4m, 4d, 1000hp, 10kts, 117p; 76belt, 19deck, 76turrets, 51CT; 2x1-152/50(3), 4x1-152/50(5,6), 2x2-120/50(3,4), 2x1-76/30(5,6)
			4	Lenin	1910		
			5	Trotsky	1910		
			6	Sverdlov	1910		
ARS	-	1	1	No14	1883		243t







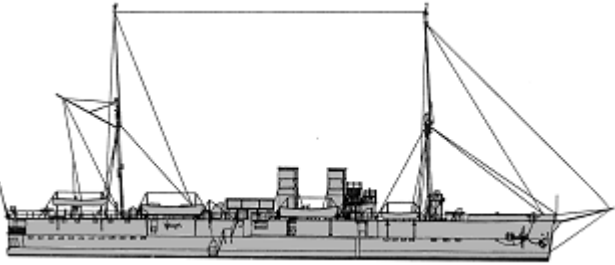

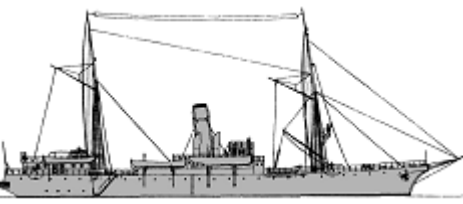
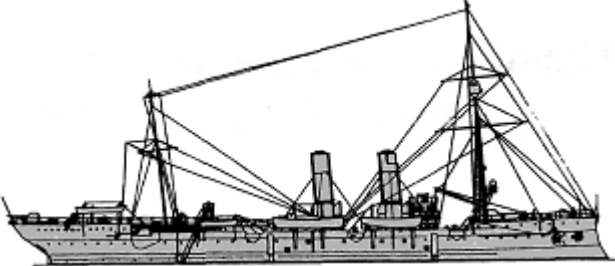
## COASTAL FORCES

PT	No1	6	1 - 6	No1, 2, 4-7, 9	1906		35t, 27.4x3.7x1.5m, 2pe, 600hp, 20kts, 11p; 1x1-47/43, 1x1-450TT
	CMB-40	7	7 - 13	No1-7	1916 - 1918		5t, 13.7x2.6x0.9m, 1pe, 275hp, 37.8kts, 4p; 1-450TT
YP	Greenport-1	3	1 - 3	Zhivuchiy, Pronzitelny, Zharkiy	1915 - 1916		15t, 18.3x3.1x0.9m, 3pe, 525hp, 21kts, 8p; 1x1-47/43, 1x1-37/23
	Greenport-2	2	4, 5	Zavidny, Dostoyny	1916		15t, 18.3x3.1x0.9m, 3pe, 525hp, 21kts, 8p; 1x1-47/43, 1x1-37/23
	Greenport-3	6	6 - 11	Schastlivy, Prytkiy, Pylkiy, Prochny, Smely, Silny	1916 - 1917		15t, 18.3x3.1x0.9m, 3pe, 525hp, 21kts, 8p; 1x1-47/43, 1x1-37/23
	Greenport-4	3	12 - 14	Besstrashny, Besshumny, Besposhchadny	1916 - 1917		24t, 22.0x3.4x0.6m, 3pe, 1080hp, 30kts, 8p; 1x1-47/43, 1x1-37/23
	Zolotov/SPOPIT	4	15 - 18	Lyogkiy, Lovkiy, Letuchiy, Likhoy	1916 - 1917		16t, 16.8x2.8x1.1m, 2pe, 250hp, 20kts, 15p; 1x1-47/43

	Chrichton/Vega	10	19 - 28	SK-43 - 45, 47, 48, 50, 54 - 56, 58	1916 - 1917		16t, 17.2x2.8x1.1m, 2pe, 240hp, 15kts; 1x1-47/43
	Mi-8	3	29 - 31	Bezuprechny, MI-12, MI-13	1919	No picture	39t, 21.0x3.2x2.0m, 2pe, 160hp, 12kts, 12p; 1x1-47/43
PGRA	Kopyo	2	1, 2	Kopyo, Pika	1910		25t, 22.2x3.1x0.5m, 2pe, 200hp, 14.5kts, 12p; 8belt, 8deck, 8CT: 1x1-76/16
	K	6	3 - 8	No1, 5, 308-311	1917		25t, 20.4x3.2x0.6m, 2pe, 150hp, 12.5kts, 12p; 5belt, 4deck, 6shields, 6CT; 2x1-76/16
	N	5	9 - 13	No1-4, SK-13	1916 - 1917		18t, 15.2x3.1x0.7m, 2pe, 100hp, 11.5kts, 8p; 7belt, 5deck, 7turret, 7CT; 1x1-76/16
	D	4	14 - 17	No1, SK-2-4	1916 - 1917		7t, 9.2x2.4x0.7m, 1pe, 80hp, 10.5kts, 7p; 5belt, 6turret, 6CT

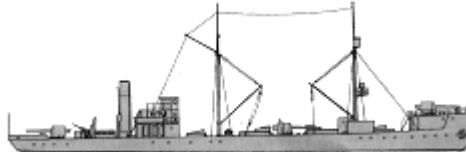
## MINE WARFARE SHIPS

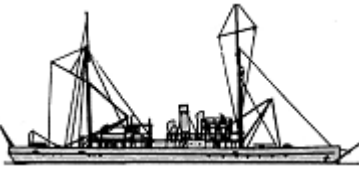
ML	General-Admiral	1	1	25 Oktyabrya	1875		5031t, 91.0x14.6x7.0m, 6b,1vc, 4470hp, 12.3kts, 490p; iron: 152belt, 25deck; 4x1-75/50, 8x1-37/20, 1-381TT, 600m
	Zagraditel	1	2	Zagraditel	1906		459t, 46.3x7.3x3.1m, 2b,1vte, 480hp, 9.5kts, 33p; 20?m
	Volga	1	3	9 Yanvarya	1909		1711t, 70.3x11.9x4.4m, 4b,2vte, 1600hp, 13.5kts, 219p; 4x1-47/43, 230m
	Amur	1	4	Amur	1909		2926t, 98.9x14.0x4.4m, 12b,2vte, 5000hp, 16kts, 312p; 5x1-120/45, 2x1-75/50, 320m
AML	-	2	1	Trud	1883		1100t, 72.7x17.0x2.5m, 1100hp, 14kts; 2x1-63/35, 2x1-47/43, 2x1-37/23, 150m
			2	Sheksna	1904		450t; 80m
NL	Berezina	2	1	Berezina	1918	No picture	450t, 50.7x16.7x2.0m, 2d(sw), 600hp, 7.5kts, 47p; 2x1-75/50, 120m, nets
			2	Yauza	1919		
	Inzhener-Mekhanik Zverev	5	1	Inzhener-Mekhanik Zverev	1906		540t, 63.6x7.0x2.7m, 4b,2vte, 6000hp, 27kts, 65p; 2x1-75/50, MS, 16m
2			Inzhener-Mekhanik Dmitriev	1906			
3			Vnimatelny	1906			

MS							
			4	Vnushitelny	1906		
			5	Vynoslivy	1906		
	No119	1	6	No142	1897		120t, 42.0x4.5x2.1m, 2b,2vte, 2000hp, 20kts, 21p; 2x5-37/20, MS
	No131	1	7	Tral	1897		100t, 38.7x5.2x2.0m, 2b,2vte, 1000hp, 21kts, 18p; 2x5-37/20, MS
	Dozorny	2	8	Dozorny	1905		100t, 30.8x5.0x1.7m, 2b,1vte, 660hp, 16kts, 31p; 1x1-37/23, MS
			9	Razvedchik	1905		
	Elpidifor	3	10	Elpidifor No416	1924		1300t, 74.7x10.4x1.8m, 2b,2vte, 750hp, 8.5kts, 169p; 3x1-130/55, 2x1-76/30, 180m, MS; 2000troops or 6 light tanks
			11	No23	1923		
			12	No24	1924		
Minrep	1	13	Zapal	1912		150t, 45.0x6.1x1.9m, 2b,2vde, 280hp, 11kts, 30p; 1x1-57/50, MS, 50m	
Kapsyul	3	14	1 Maya	1916		248(14)-271(15,16)t, 53.0x6.6x1.0(14)-1.2(15,16)m, 2b,2vte, 650hp, 9kts, 38p; 1x1-75/50, MS	
		15	Kapsyul	1916			
		16	Gruz	1916			
Udarnik	2	17	Udarnik	1917		220m, 43.6x6.1x1.7m, 2b,2vte, 400hp, 11kts, 35p; 1x1-75/50, 1x1-47/43, MS	
		18	Klyuz	1917			
AMS	-	17	1	Garpun	1912		310t; 2x1-75/50
			2	Zmey	1914		200t
			3	Nevod	1915		310t; 1x1-75/50
			4	Piksha	1880		128t
			5	Yakor	1915		310t; 2x1-75/50
			6	Buy	1899		186t
			7	Fugas	1895		140t; 1x1-75/50
			8	Provodnik	1895		140t
			9	Shchit	1900		150t; 1x1-75/50
			10	No13	1883		173t
			11	No17	1915		100t
			12	Tovarishch Saenko	1908		203t
			13	Samson	1871		240t
			14	No24	1924		500t

			15	No16	1912		225t
			16	No18	1910		250t
			17	Sofiya	1883		420t
AMSR	-	1	1	Bednota	1894		230t
MSB	Chayka	1	1	Chayka	1911		24t, 15.5x3.7x1.2m, 1pe, 100hp, 9.5kts; 1x1-37/23, MS

## BOARD GUARD SHIPS

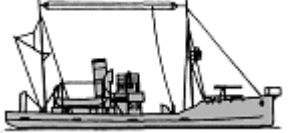
PC	Barsuk	4	1	Atarbekov	1916		202t, 30.5x5.8x2.7m, 1b,1vte, 350hp, 11kts, 46p; 2x1-75/50, 1x1-37/23
			2	Laska	1916		
			3	Mogilevskiy	1916		
			4	Vydra	1916		
	T.13	1	5	PS-1	1916		580t, 43.2x7.2x3.5m, 1b,1vte, 500hp, 11kts, 35p; 1x1-57/50, MS, 30m
APC	-	2	1	Sovetskiy Azerbaydzhan	1893		1091t, 74.8x9.6x4.0m, 640hp, 14kts; 2x1-130/55
			2	Vorovskiy	1901		3315t, 96.6x12.2x5.5m, 6000hp, 18kts; 2x1-120/45

[home](#)

[World navies yesterday](#)

[1925](#)

# Spain 01 January 1925

## CAPITAL SHIPS

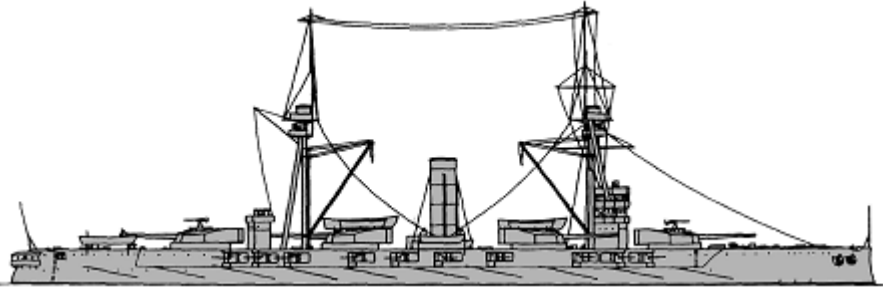
BB	España	1	Alfonso XIII	1915		15700t, 139.9x24.0x7.8m, 12b,4t, 15500hp, 19.5kts, 854p; 230belt, 90deck, 234turrets, 250CT; 4x2-305/50, 20x1-102/50, 4x1-47/40
		2	Jaime I	1921		

## AIRCRAFT CARRYING SHIPS

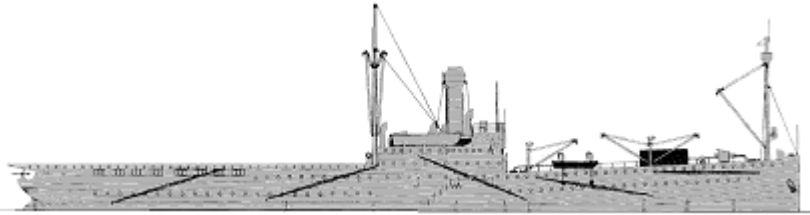

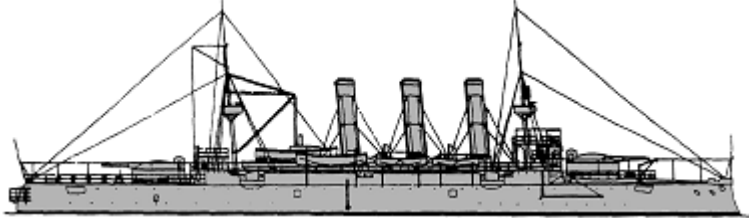

AV	Dédalo	1	1	Dédalo	1901		9900t, 128.0x16.8x7.4m, 3b,1vte, 2200hp, 10kts, 398p; 2x1-105/35, 2x1-57/42, 20seaplanes (M.18), 1airship (SCA), 2balloons
----	--------	---	---	--------	------	--	--

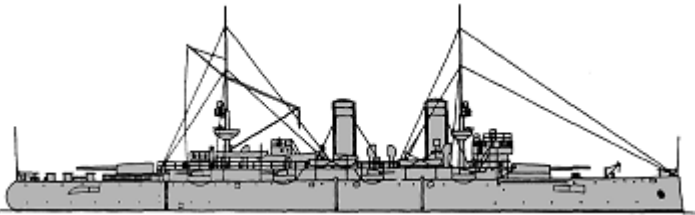
## CRUISERS

CA	Carlos V	1	1	Carlos V	1897		10100t, 115.8x20.4x7.6m, 12b,2vte, 18500hp, 20kts, 583p; 50belt, 165deck, 100turrets, 300CT; 2x1-280/35, 4x1-105/32, 8x1-12.7, 2-356TT
	Princesa de Asturias	2		Princesa de Asturias	1903		
	Princesa de Asturias	2					7549t, 111.0x18.6x6.6m, 6b,2hte, 14800hp, 20kts, 542p; Harvey; 300belt, 57deck,

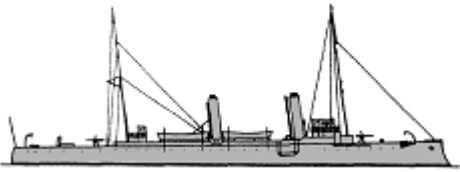
						100turrets, 200CT; 2x1-240/42, 8x1-140/35, 8x1-57/42, 10x1-37/27, 5-450TT
		3	Cataluña	1904		
		1	1	Infanta Isabel	1888	1152t, 67.4x9.8x3.9m, 4b,1hc, 1500hp, 13kts, 173p; 1x1-70/38, 10x1-57/42
		1	2	Río de La Plata	1900	1950t, 76.3x10.8x4.4m, 4b,2vte, 7100hp, 20kts, 213p; steel; 20slopes, 15deck, 120CT; 2x1-140/35, 4x1-105/32, 20m
		1	3	Extremadura	1902	2180t, 88.4x11.0x4.3m, 4b,2vte, 7000hp, 20kts, 246p; 50deck, 30CT; 8x1-102/50, 2x1-75/12, 4x1-57/42, 2x1-37/23
CL		1	4	Reina Regente	1910	5871t, 110.9x16.1x5.0m, 12b,2vte, 11000hp, 19.5kts, 497p; 120slopes, 90deck, 75shields, 90CT; (2x2+6x1)-150/45, 12x1-57/42, 8x1-37/37
		1	5	Reina Victoria Eugenia	1923	6450t, 140.8x15.2x4.8m, 12b,2t, 25500hp, 25kts, 404p; 50belt, 38deck, 152shields, 152CT; 9x1-152/50, 1x1-76/19, 4x1-47/50, 2x2-533TT
		1	6	Méndez Núñez	1924	6045t, 140.8x14.1x4.4m, 12b,4gt, 45000hp, 29kts, 343p; 76belt, 25deck, 150CT; 6x1-152/50, 1x1-76/19, 4x1-47/50, 4x3-533TT

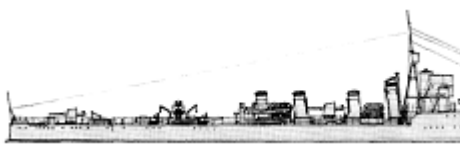

## TORPEDO SHIPS

PGT	María de Molina	3	1	María de Molina	1898		830t, 71.6x8.0x2.7m, 4b,2vte, 3500hp, 19.5kts, 91p; 152CT; 8x1-57/42(1,2), 6x1-57/42(3), 2x1-47/42(3), (1+2x1)-356TT
			2	Marqués de la Victoria	1900		
			3	Álvaro de Bazán	1900		
DD	Audaz	2	1	Osado	1898		430(1)-457(2)t, 69.8x6.9x1.8m, 4b,2vte, 7500hp, 30kts, 67p; 2x1-75/43, 2x1-57/42, 2x1-37/27, 2x1-356TT, 20m
			2	Proserpina	1898		
	Bustamante	3	3	Bustamante	1914		530t, 67.4x6.7x1.7m, 3b,3t, 6250hp, 28kts, 70p; 5x1-57/40, 2x2-450TT(3,4), 2x2-381TT(5), 20m
			4	Villaamil	1916		
			5	Cadarso	1917		
	Alsedo	2	6	Alsedo	1924		1337t, 86.8x8.2x4.5m, 4b,2gt, 33000hp, 34kts, 86p; 3x1-102/45, 2x1-47/50, 2x2-450TT, 1DCR, 60m
			7	Velasco	1924		
TB	T-1	22	1	T-1	1912		190t, 52.3x5.0x1.5m, 2b,3(1-7)-2(8-22)t, 3750hp, 26kts, 31p; 3x1-47/50, (1x2+1x1)-450TT
			2	T-2	1912		
			3	T-3	1912		
			4	T-4	1913		
			5	T-5	1914		
			6	T-6	1915		
			7	T-7	1915		
			8	T-8	1915		
			9	T-9	1915		
			10	T-10	1915		
			11	T-11	1916		
			12	T-12	1916		
			13	T-13	1916		
			14	T-14	1916		
			15	T-15	1917		
			16	T-16	1917		
			17	T-17	1917		
			18	T-18	1918		
			19	T-19	1920		
			20	T-20	1920		
			21	T-21	1921		
			22	T-22	1921		

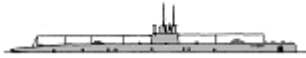
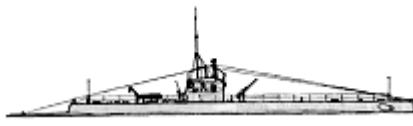
## SUBMARINES

SS	Isaac Peral	1	1	Isaac Peral	1917		488/750t, 60.1x5.8x3.4m, 2d/em, 1200/680hp, 15/10kts, 28p, 50m; 1x1-76/23, 4-450TT
	A1	3	2	A1 Narciso Monturiol	1917		262/319t, 45.6x4.2x3.1m, 2d/em, 700/500hp, 12.8/8kts, 17p, 45m; 2-450TT
			3	A2 Cosme García	1917		
			4	A3	1917		
	B1	4	5	B1	1922		556/740t, 64.2x5.6x3.4m, 2d/em, 1400/420hp, 16.2/10.5kts, 28p, 60m; 4-450TT
			6	B2	1922		
			7	B3	1922		
			8	B4	1923		



## ESCORTS

PC	Delfin	3	1	Delfin	1911	No picture	158t, 11kts; 1x1-57/42
			2	Dorado	1911		
			3	Gaviota	1911		
	Uad Lucas	5	4	Uad Lucas	1917		547t, 40.8x7.2x2.8m, 1b,1vte, 480hp, 10.5kts, 39p; 1x1-76/50
			5	Uad Martin	1917		
			6	Uad Muluya	1917		
			7	Uad Ras	1918		
			8	Uad Targa	1918		
	Uad Kert	3	9	Uad Kert	1917		665t, 45.1x7.2x2.8m, 1b,1vte, 600hp, 11kts, 45p; 1x1-76/50(9,11), 2x1-76/50(10), 1x1-47/50(11)
			10	Arcila	1918		
			11	Xauen	1918		
	Alcázar	3	12	Alcázar	1919		440t, 41.0x7.3x3.2m, 1b,1vte, 425hp, 11kts, 41p; 1x1-76/50, 1x1-57/42(14), 2x1-47/50(12)
			13	Larache	1919		
			14	Tetuán	1919		
FPV	Condestable Zaragoza	8	1	Condestable Zaragoza	1919	No picture	150t, 24.5x6.0x2.7m, 1b,1vte, 300hp, 11kts, 11p; 1x1-42/42
			2	Cabo de Infantería Marina Garciolo	1919		
			3	Contramaestre Castelló	1919		
			4	Maquinista Macías	1919		
			5	Torpedista Hernández	1919		
			6	Marinero Cante	1919		
			7	Fogonero Bañobre	1919		
			8	Marinero Jarana	1919		

## OTHER FIGHTING SHIPS

	Mac-Mahón	1	1	Mac-Mahón	1888	No picture	115t, 27.6x4.9x1.8m, 2b,2vte, 150hp, 9kts, 15p; 2x1-42/42, 1x5-37/20
			2	Hernan Cortés	1895		

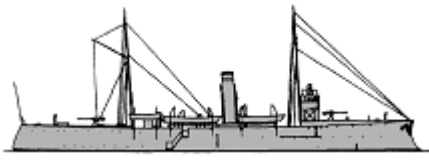
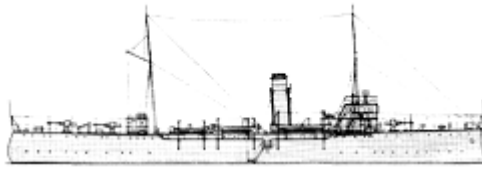

PG	Hernan Cortés	2	3	Pizarro	1895	No picture	295t, 47.4x6.6x1.9m, 1b,1vte, 352hp, 13kts, 53p; 2x1-75/43, 2x1-57/42	
	Recalde	4	4	Recalde	1911		811t, 65.5x9.1x3.0m, 2b,2vte, 1200hp, 13.5kts, 130p; 4x1-76/50	
			5	Laya	1911			
			6	Bonifaz	1911			
			7	Lauria	1912			
	Antonio Cánovas del Castillo	2	8	Antonio Cánovas del Castillo	1923		1335t, 77.3x10.2x3.4m, 2b,2vte, 1700hp, 15kts, 132p; 4x1-102/45, 2x1-47/50	
			9	José Canalejas	1924			
	PR	Perla	1	1	Perla	1887	No picture	42t
		Cartagenera	1	2	Cartagenera	1908		27t, 16.3x3.6x1.2m, 1b,1vc, 120hp, 12kts; 1x1-42/42

### COASTAL FORCES

YP	M1	6	1-6	M1-6	1918		37t, 24.4x3.7x1.2m, 2pe, 440hp, 19kts, 8p; 1x1-47/50, 2DCR, MS		
YP(Ta)	I1	6	C.I	18	1-18	C.I-XVIII	1922-1924	No picture	36t, 22.8x4.0x1.4m, 2d, 180hp, 12kts, 6p
			19	I1	1923	No picture	128t, 33.5x2.6x1.8m, 2d, 600hp, 13kts		
			20	I2	1923				
			21	I3	1923				
			22	I4	1923				
			23	I5	1923				
24	I6	1923							

### AMPHIBIOUS SHIPS AND CRAFTS

LCT	K1	16	1	K1	1915		160t, 32.2x6.4x1.5m, 1sd, 60hp, 8kts, 15p; 300troops or 150t cargo
			2	K2	1915		
			3	K3	1915		
			4	K4	1915		
			5	K5	1915		
			6	K6	1915		
			7	K7	1915		
			8	K8	1915		
			9	K9	1915		
			10	K10	1915		
			11	K11	1915		
			12	K12	1915		
			13	K13	1915		
			14	K14	1915		

			15	K15	1915
			16	K16	1915

## MINE WARFARE SHIPS AND CRAFTS

ML	Anteo	1	1	Anteo	1903	No picture	342t, 40.0x6.6x2.1m, 1b,1vte, 650hp, 11kts; 40m, MS
----	-------	---	---	-------	------	------------	---

© Ivan Gogin, 2011-14

[home](#)[World navies yesterday](#)[1925](#)

# Sweden 01 January 1925

## CAPITAL SHIPS

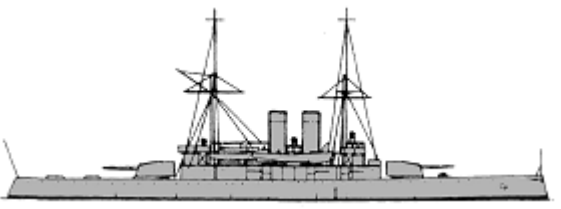
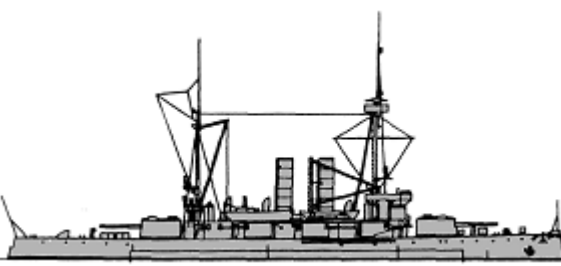
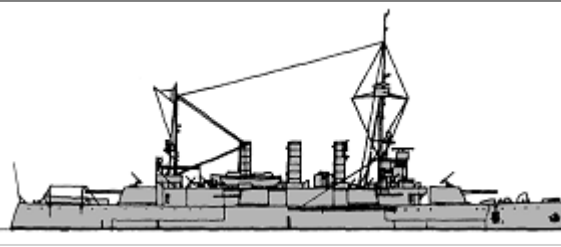

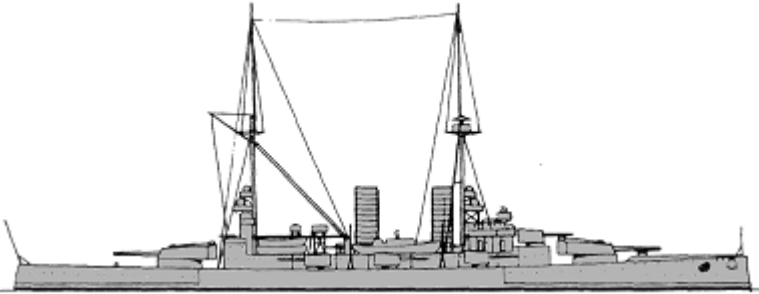
Oden	3	1	Oden	1897		3715(1)-3720(2,3)t, 86.3x14.8x5.3m, 6b,2vte, 5350hp, 16.5kts, 254p; 243(s,1)-240(h,2,3)belt, 49(s,1)-49(h,2,3)deck, 200(s,1)-190(n,2,3)turrets, 247(s,1)-190(h,2,3)CT; 2x1-254/42, 4x1-120/45(1), 6x1-120/45(2,3), 10x1-57/55
		2	Thor	1899		
		3	Njord	1899		
Dristigheten	1	4	Dristigheten	1901		3600t, 89.0x14.8x4.9m, 8b,2vte, 5400hp, 16.5kts, 275p; h: 200belt, 50deck, 200turrets, 247CT; 2x1-210/44, 6x1-152/44, 10x1-57/55, 2-450TT
Äran	4	5	Äran	1902		3735t, 89.7x15.0x5.0m, 8b,2vte, 6500hp, 17kts, 275p; 175belt, 48deck, 190turrets, 200CT; 2x1-210/44, 6x1-152/44, 10x1-57/55, 2x1-37/35, 2-450TT
		6	Wasa	1902		
		7	Tapperheten	1903		
		8	Manligheten	1904		
Oscar II	1	9	Oscar II	1907		4584t, 95.6x15.4x5.5m, 10b,2vte, 9400hp, 18kts, 331p; 150belt, 50deck, 190turrets, 157CT; 2x1-210/44, 4x2-152/50, 10x1-57/55, 3x1-37/35, 2-450TT
		10	Sverige	1917		7516(10)-7633(11,12)t, 120.0(10)-121.6(11,12)x18.6x6.3(10)-6.2(11,12)m, 12b, 4t(10)-2gt(11,12),
		11	Drottning Victoria	1921		

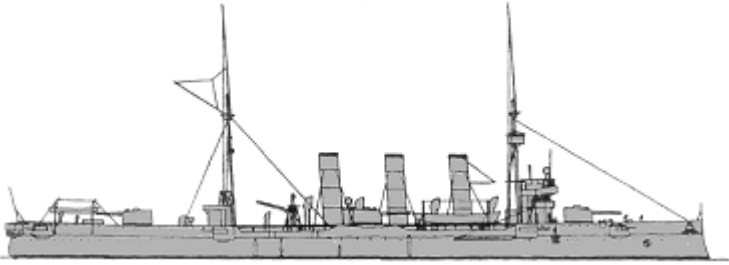
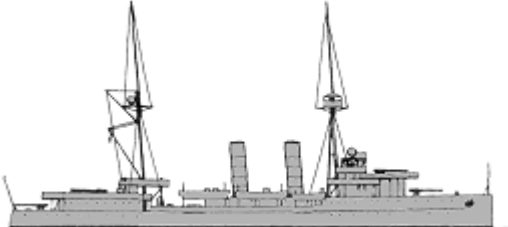

	Sverige	3					25400(10)-23910(11,12)hp, 22.5kts, 427p; 200belt, 45deck, 200turrets, 175CT; 2x2-283/45, (1x2+6x1)-152/50, 6x1-75/50, 2x1-57/55, 2-533TT
			12	Gustaf V	1922		

## CRUISERS

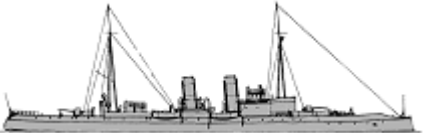

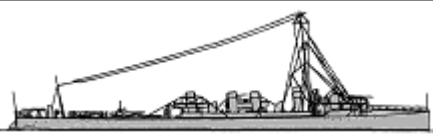
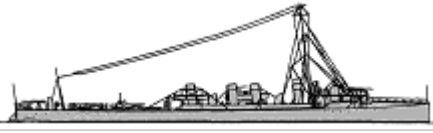

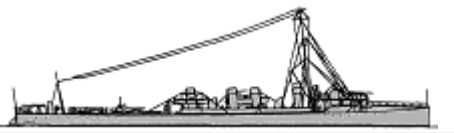
CA	Fylgia	1	1	Fylgia	1907		4734t, 115.1x14.8x6.3m, 12b,2vte, 12000hp, 21.5kts, 320p; 100belt, 35deck, 125turrets, 100CT; 4x2-152/50, 14x1-57/55, 2-450TT
CM	Clas Fleming	1	1	Clas Fleming	1914		1800t, 80.2x10.4x4.3m, 8b,2t, 6500hp, 20kts, 160p; 25deck, 75CT; 4x1-120/50, 100m

## TORPEDO SHIPS

PGT	Örnen	3	1	Örnen	1897		844(1)-835(2)-814(3)t, 67.7(1,2)-70.7(3)x8.2(1,2)-8.3(3)x3.1(1,2)-3.0(3)m, 8b,2vte, 4000(1,2)-4500(3)hp, 20kts, 113p; 19deck; 2x1-120/45, 4x1-57/55, 1-380TT	
			2	Jacob Bagge	1898			
			3	Psilander	1900			
DD	Mode	1	1	Mode	1902		453t, 67.1x6.2x2.7m, 4b,2vte, 6000hp, 30kts, 62p; 6x1-57/55, 2x1-450TT	
			2	Magne	1905			
	Wale	1	3	3	Wale	1908		461t, 66.1x6.3x2.8m, 4b,2vte, 7665hp, 30kts, 54p; 2x1-75/50, 4x1-57/55, 2x2-450TT
				4	Vidar	1910		
	Ragnar	3	6	5	Ragnar	1909		460t, 66.1x6.3x2.7m, 4b,2vte, 7200hp, 30kts, 54p; 4x1-75/50, 2x2-450TT
				6	Sigurd	1909		

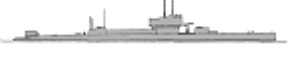

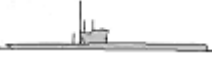



	Hugin	2	7	Hugin	1911		500t, 66.3x6.5x3.5m, 4b,2t, 10000hp, 33kts, 72p; 4x1-75/50, 2x2-450TT
			8	Munin	1913		
	Wrangel	2	9	Wrangel	1918		498t, 72.0x6.9x2.8m, 4b,2gt, 13000hp, 34kts, 81p; 4x1-75/50, (2x2+2x1)-450TT
			10	Wachtmeister	1918		
TB	Plejad	17	1	Plejad	1905		106t, 40.2x4.4x2.6m, 1b,`vte, 2000hp, 26kts, 25p; 2x1-37/39, (1+1x1)-450TT
			2	Iris	1908		
			3	Thetis	1908		
			4	Spica	1908		
			5	Astrea	1908		
			6	Antares	1909		
			7	Arcturus	1909		
			8	Altair	1909		
			9	Argo	1909		
			10	Polaris	1909		
			11	Perseus	1910		
			12	Regulus	1910		
			13	Rigel	1910		
			14	Castor	1909		
			15	Pollux	1909		
			16	Vega	1910		
			17	Vesta	1910		

## SUBMARINES

SS	No2	3	1	No2	1909		138/230t, 26.8x3.6x3.0m, 1d/em, 420/200hp, 8.8/6.6kts, 12p, 30m; 1-450TT
			2	No3	1909		
			3	No4	1910		
	Svärdfisken	2	4	Svärdfisken	1915		252/370t, 45.5x4.2x3.0m, 2d/em, 1000/300hp, 14.2/8.5kts, 21p, 30m; 1x1-57/55, 2-450TT
			5	Tumlaren	1915		
	Delfinen	1	6	Delfinen	1915		260/370t, 42.5x4.3x3.0m, 2d/em, 1000/300hp, 13.6/9.4kts, 21p, 30m; 1x1-37/39, 2-450TT
	Laxen	2	7	Laxen	1915		140/170t, 26.8x3.6x3.0m, 2d/em, 700/200hp, 8.8/6.6kts, 10p, 30m; 1-450TT
			8	Gäddan	1915		
	Abborren	2	9	Abborren	1917		174/310t, 31.0x3.6x3.1m, 2d/em, 920/280hp, 9.5/7.4kts, 14p, 30m; 2-450TT
			10	Braxen	1917		
	Hajen	3	11	Hajen	1920		422/600t, 54.0x5.2x3.5m, 2d/em, 2000/700hp, 15.5/9kts, 30p, 30m; 1x1-75/50, 4-450TT
			12	Sälen	1920		
			13	Valrossen	1920		
				14	Bävern	1921	

Bävern	3	15	Illern	1921		472/650t, 57.0x5.8x3.0m, 2d/em, 2100/520hp, 15.2/8.2kts, 28p, 30m; 1x1-57/55, 4-450TT
		16	Uttern	1921		

## ESCORTS

PC	Blixt	2	1, 2	V7, 8	1883 - 1885		43t, 30.5xxm, 1b, 1vce, 420hp, 19kts; 1x1-25/35, MS
	Narf	2	3, 4	V9, 10	1886		45t, 30.7x3.6x1.9m, 1b,1vce, 440hp, 19.5kts; 1x1-25/35, MS
	Gondul	2	5, 6	V21, 22	1894		86t, 38.6x4.3x2.1m, 1b,1vce, 850hp, 19.5kts, 18p; 2x1-25/60
	Komet	12	7	V20	1896		120t, 39.8x4.8x2.5m, 1b,1vce, 1300hp, 23kts, 18p; 2x1-37/39, MS
			8	V27	1898		
			9	V28	1899		
			10	V29	1899		
			11	V30	1900		
			12	V31	1900		
			13	V32	1900		
14			V33	1902			
15			V34	1902			
16	V35	1903					
17	V36	1903					
18	V37	1904					
No83	2	19, 20	V23, 24	1903		56t, 32.4x3.6x1.9m, 1b,1vce, 635hp, 20.8kts; 1x1-37/39, MS	
No79	2	21, 22	V25, 26	1903		55t, 31.7x3.6x1.9m, 1b,1vce, 700hp, 20.5kts; 1x1-37/39, MS	

## COASTAL FORCES

PT	Mtb1	2	1, 2	Mtb1, 2	1918		13t, 16.4x2.8x1.4m, 2pe, 500hp, 28kts, 8p; 2-450TT, 4DC
----	------	---	------	---------	------	---	---

## MINE WARFARE

ML	Blenda	1	1	Disa	1877	No picture	550t, 51.1x8.1x3.0m, 2b, 2hce, 590hp, 11.5kts, 71p; h: 51CT; 1x1-152/26, 2x1-57/55, 20m
	Urd	1	2	Rota	1878	No picture	550t, 53.6x8.1x2.8m, 2b, 2hce, 780hp, 13.4kts, 72p; 1x1-57/21, 20m
	Mul 3	1	3	Mul 3	1879	No picture	190t, 6.5kts; 20m
	Mul 5	4	4	Mul 5	1904	No picture	120t, 7.5kts; 20m
			5	Mul 6	1904		
			6	Mul 7	1904		
7			Mul 8	1905			
Mul 9	1	8	Mul 9	1912	No picture	120t, 9.1kts; 20m	
MS	Sökaren	3	1	Sökaren	1918	No picture	266t, 27.8x6.8x3.0m, 1b,1vte, 465hp, 10kts, 17p; 1x1-57/21, 10m, MS
			2	Sveparen	1918		

© Ivan Gogin, 2011-14

[home](#)[World navies yesterday](#)[1925](#)

## Turkey 01 January 1925

### CAPITAL SHIPS

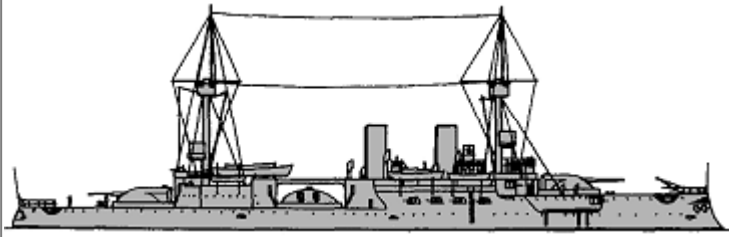
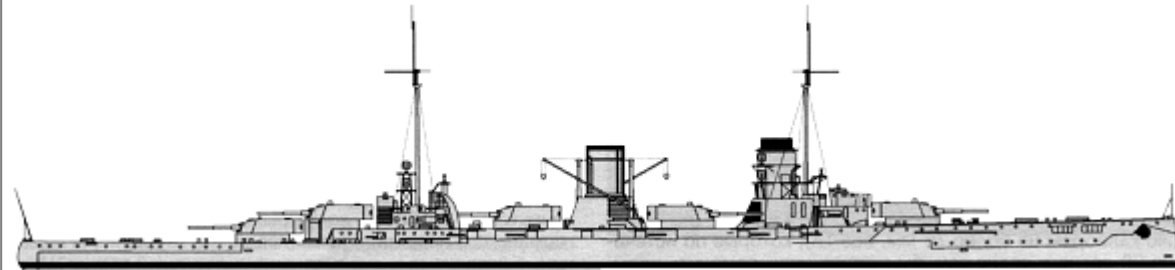
BB	Torgud Reis	1	1	Torgud Reis	1894		10670t, 115.7x19.5x7.6m, 12b,2vte, 10200hp, 16.5kts, 600p; Harvey- 400belt, 60deck, 300barbettes, 300CT; 2x2-280/40, 1x2-280/35, 6x1-88/30, 3-450TT
CB	Yavuz Sultan Selim	1	1	Yavuz Sultan Selim	1912		25400t, 186.6x29.5x8.7m, 24b,4t, 52000hp, 25.5kts, 1053p; 270belt, 50deck, 230turrets, 350CT; 5x2-283/47, 10x1-150/45, 16x1-88/45, 4-500TT



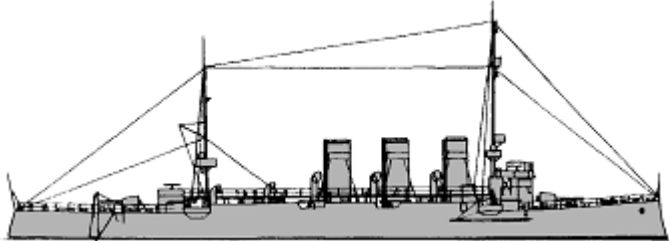

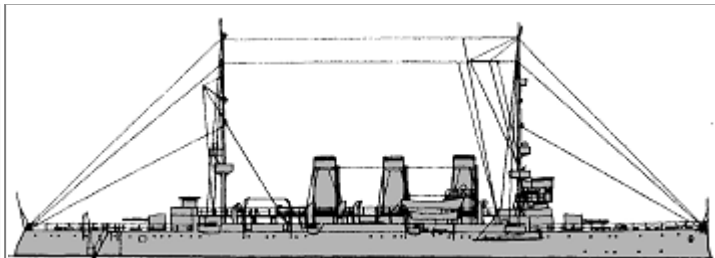

### CRUISERS

CL	Mecidiye	1	1	Mecidiye	1903		3967t, 102.4x12.8x4.8m, 16b,2vqe, 12500hp, 22kts, 312p; 38deck, 102slopes; 2x1-152/45, 2x1-120/45, 2-450TT
	Hamidiye	1	2	Hamidiye	1904		3904t, 112.0x14.5x4.88m, 6b,2vte, 12000hp, 22kts, 302p; 38deck, 102slopes; 2x1-152/45, 6x1-120/50, 2x1-47/50, 2x1-37/50, 2x1-450TT

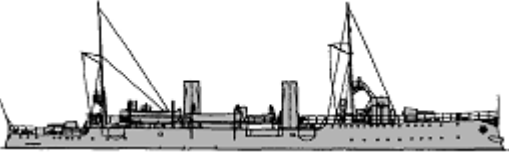





## TORPEDO SHIPS

PGT	Peyk-i Şevket	1	Peyk	1907		775t, 80.1ppx8.4x4.6m, 4b,2vte, 5100hp, 21kts, 105p; 2x1-105/40, 6x1-57/40, 2x1-37/50, (1+2x1)-450TT
		2	Berk	1907		
DD	Samsun	1	Samsun	1907		284t, 58.2x6.3x2.8m, 2b,2vte, 5950hp, 28kts, 23p; 1x1-65/50, 6x1-47/50, 2x1-450TT
		2	Taşoz	1907		
		3	Basra	1907		
TB	Hamidiye	1	Yunus	1902		145t, 50.6x5.6x1.2m, 3b,2vte, 2400hp, 26kts, 30p; 1x1-47/45
	Akhisar	1	Akhisar	1904		165t, 51.0x5.7x1.4m, 2b,2vte, 2400hp, 24kts, 30p; 1x1-47/45, 2x1-37/23, 1x1-450TT
	Antalya	1	Musul	1907		165t, 51.0x5.7x1.4m, 2b,2vte, 2700hp, 26kts, 30p; 1x1-47/45, 2x1-37/23, 2x1-450TT
	Demirhisar	2	4 Sultanhisar	1907		101t, 40.2x4.4x1.9m, 2b,1vte, 2200hp, 26kts, 23p; 2x1-37/23, (1+1x2)-450TT
	5 Sivrihisar	1907				

## ESCORTS

PC	-	1	1	Rüsumet No1	1901	143t
----	---	---	---	-------------	------	------

## OTHER FIGHTING SHIPS

PG	Aydin Reis	1	Aydin Reis	1914		503t, 54.5x8.2x2.4m, 3b,2vte, 1025hp, 14kts, 75p; 2x1-75/55(1,2), 2x1-47/50(3,4)
		2	Preveze	1914		
		3	Sakiz	1914		
		4	Bürak Reis	1914		
	İsa Reis	5	İsa Reis	1914		413t, 47.0x7.9x1.3m, 3b,2vte, 850hp, 14kts, 60p; 3x1-75/50, 2x1-47/50
		6	Kemal Reis	1914		
		7	Hizir Reis	1914		
ADV	-	1	1	Galata	1896	120t

## COASTAL FORCES

YP	No1	10	1-10	No11, 13-15, 17, 18, 20-23	1914		20t, 18.3ppx3.3x1.6m, 2pe(1), 70hp, 11.9kts, 6p; 1x1-37/37
----	-----	----	------	----------------------------	------	---	--

## MINE WARFARE SHIPS

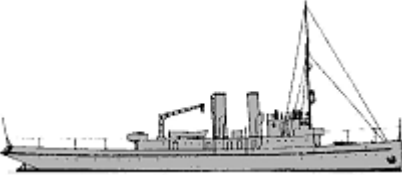
ML	Nusret	1	1	Nusret	1913		365t, 40.2ppx7.6x3.4m, 2b,2vte, 1200hp, 15kts; 2x1-47/45, 40m
AML	-	2	1	Selanik	1900s		270brt; 25m
			2	Uyanik	1886		616brt; 1x1-75/35, 50m

© Ivan Gogin, 2011-15

[home](#)



[World navies yesterday](#)

[1925](#)





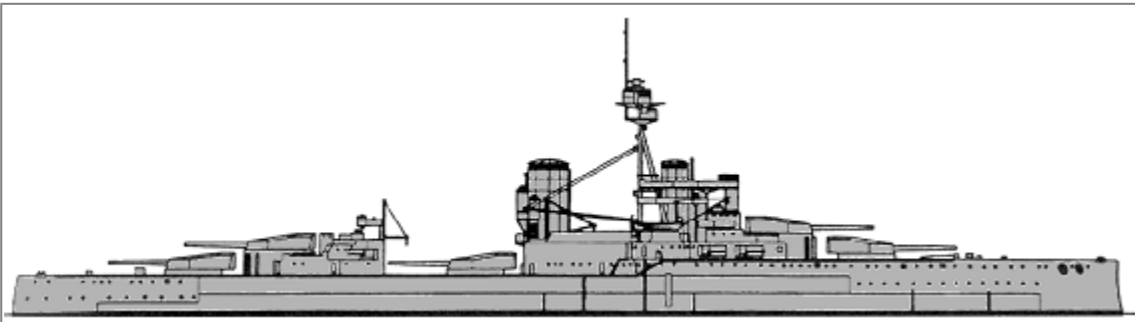
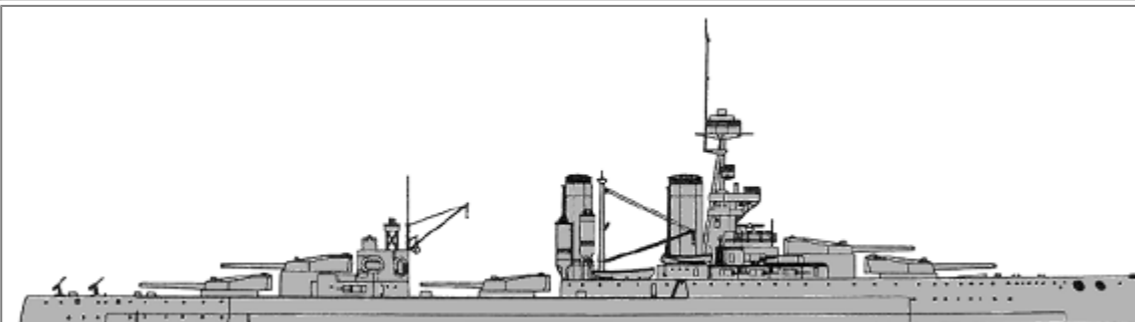

## United Kingdom 01 January 1925

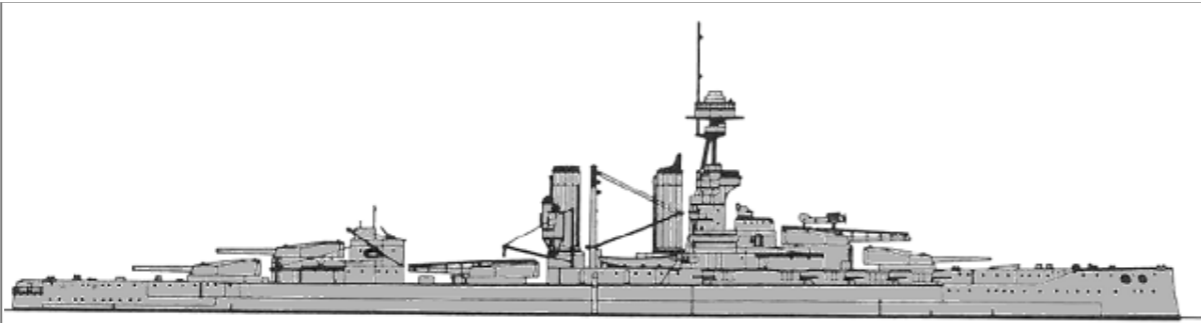
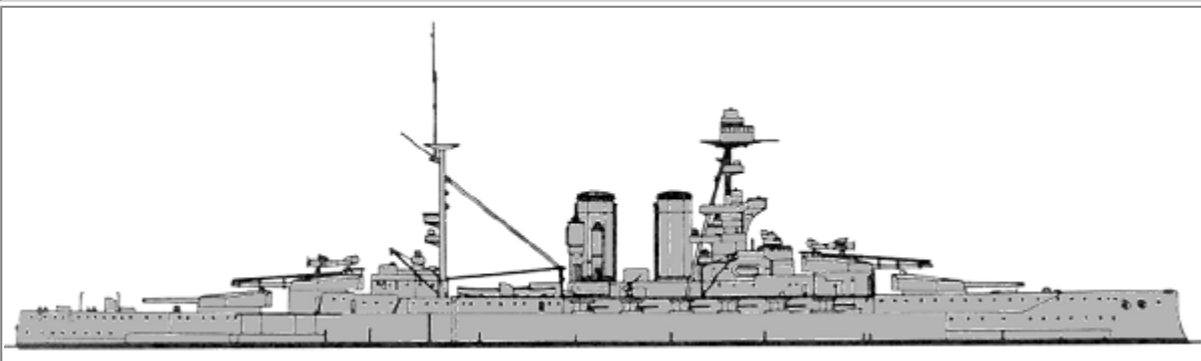
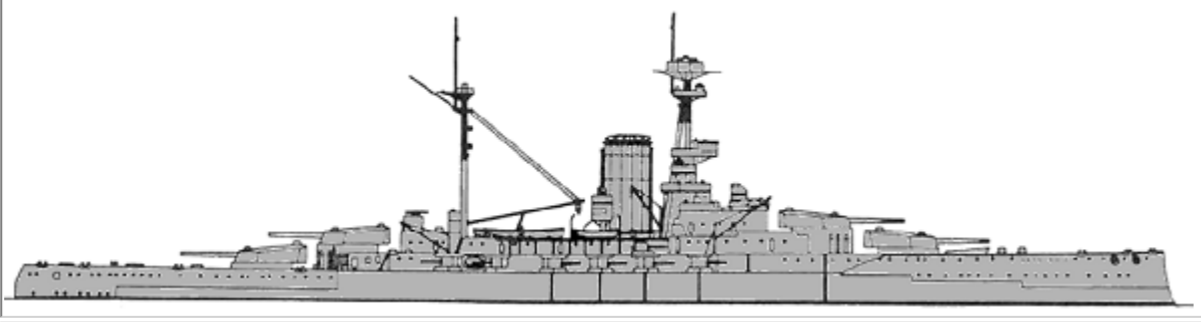
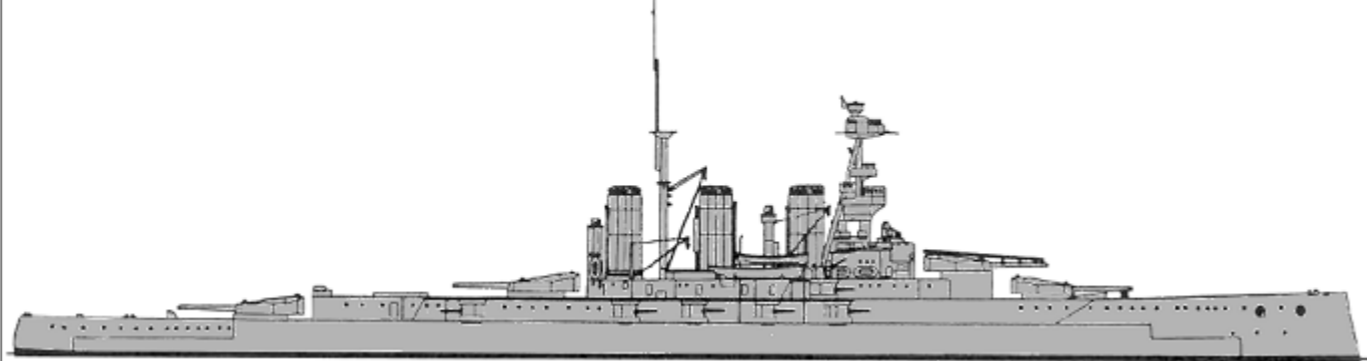
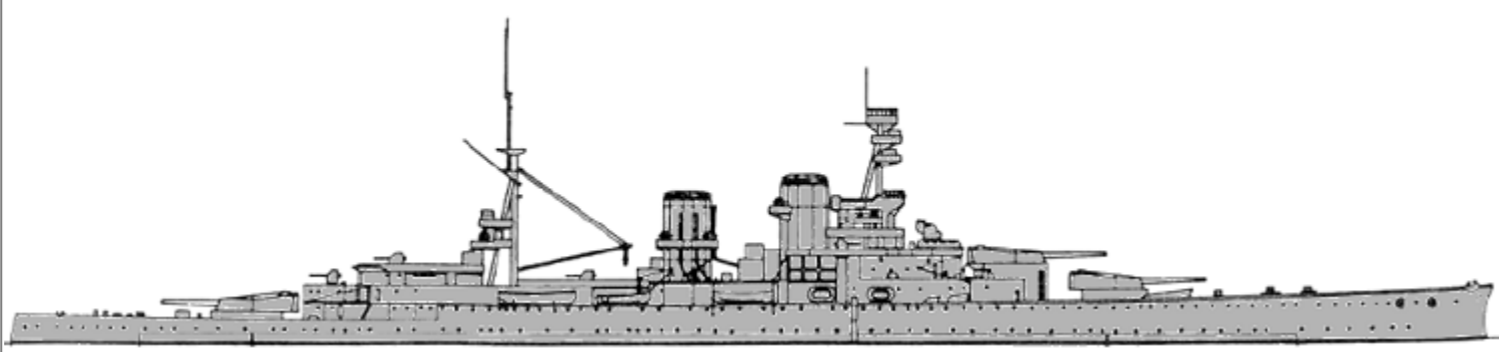
*IN SERVICE: 18 battleships, 4 battlecruisers, 2 light battlecruisers, 7 monitors, 2 small monitors, 2 fleet aircraft carriers, 3 light aircraft carriers, 1 seaplane tender, 2 heavy cruisers, 4 protected cruisers, 36 light cruisers, 1 masted sloop, 21 destroyer leaders, 171 destroyers, 64 submarines, 29 sloops, 11 patrol ships, 1 patrol craft, 2 gunboats, 17 river gunboats, 31 motor torpedo boats, 8 patrol launches, 23 small landing ships, 2 non-self-propelled landing ships, 1 auxiliary minelayer, 61 minesweepers, 34 armed trawlers, 37 armed drifters*

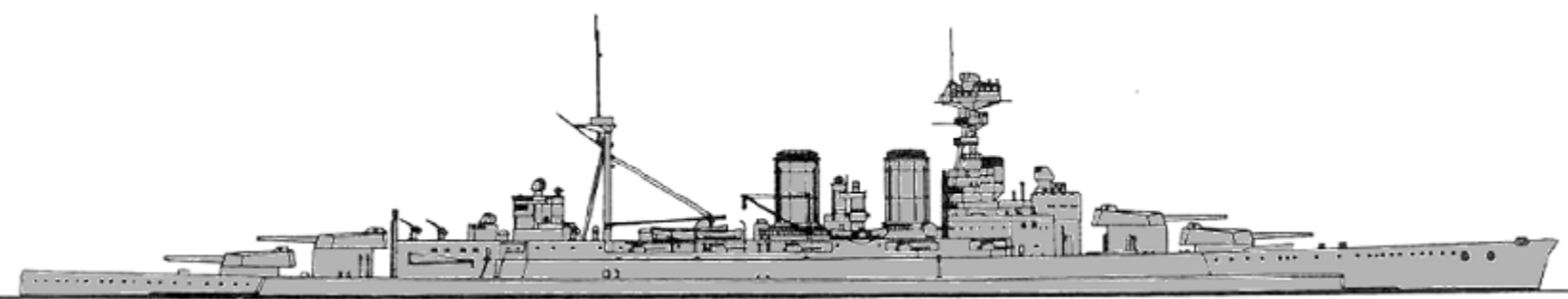
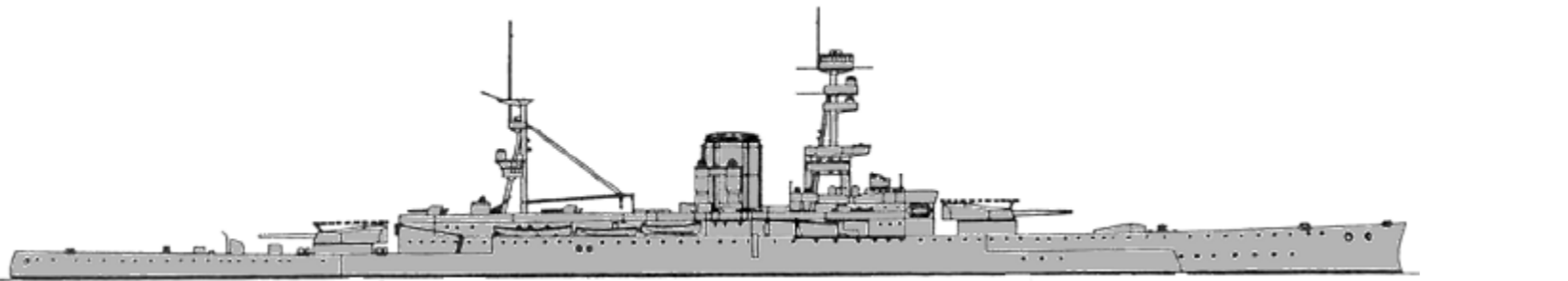
### CAPITAL SHIPS AND MONITORS

	Orion	1	1	Thunderer	1912		25870t, 177.1x27.0x7.6m, 18b,4t, 27000hp, 21kts, 752p; 305belt, 102deck, 280turrets, 254CT; 5x2-343/45, 8x1-102/50, 1x1-76/45, 4x1-47/40, 3-533TT
	King George V	2		King George V	1912		25700t, 182.1x27.1x8.7m, 18b,4t, 31000hp, 21kts, 782p; 305belt, 102deck, 280turrets, 280CT; 5x2-343, 14x1-102/50, 4x1-47/40, 3-533TT
		3		Ajax	1913		
		4		Centurion	1913		
BB	Iron Duke	5		Iron Duke	1914		30380t, 189.8x27.4x9.0m, 18b,4t, 29000hp, 21.2kts, 1022p; 305beltd, 114deck, 280turrets, 305CT; 5x2-343/45, 12x1-152/45, 2x1-76/45, 4x1-47/40, 4-533TT
		6		Marlborough	1914		
		7		Benbow	1914		
		8		Emperor of India	1914		

						
Queen Elizabeth	5	9	Queen Elizabeth	1915		31500t, 196.8x27.6x8.8m, 24b,4t, 56000hp, 23-24kts, 925-951p; 330belt, 127deck, 330turrets, 280CT; 4x2-381/42, 12x1-152/45, 4x1-76/45, 4x1-47/40, 4-533TT
		10	Warspite	1915		
		11	Barham	1915		
		12	Valiant	1916		
		13	Malaya	1916		
Revenge	5	14	Revenge	1916		32526(14,17)-32100(15)-32474(16)-33500(18)t, 190.3x30.9(14,17)-31.1(15)-31.0(16)-31.3(18)x8.3(14,17)-8.7(15,16)-8.4(18)m, 18b,4gt, 40000hp, 22(14-17)-21.5(18)kts, 908-997p; 330belt, 140deck, 330turrets, 280CT; 4x2-381/42, 14x1-152/45, 2x1-76/45, 4x1-47/40, 4-533TT
		15	Royal Oak	1916		
		16	Royal Sovereign	1916		
		17	Resolution	1916		
		18	Ramillies	1917		
CB	2	1	Tiger	1914		35710t, 214.6x27.6x8.7m, 39b,4gt, 85000hp, 28kts, 1121p; 229belt, 76deck, 229turrets, 254CT; 4x2-343/45, 12x1-152/45, 2x1-102/45, 4x1-47/40, 4-533TT
		3	Repulse	1916		30835(2)-37490(3)t, 242.0x27.4(2)-30.8(3)x7.8(2)-9.6(3)m, 42b,4t, 112000hp, 30kts, 967p; 152(2)-229(3)belt, 102deck, 229turrets, 254CT; 3x2-381/42, (4x3+2x1)-102/45(2), (5x3+4x1)-102/45(3), 2x1-76/45(2), 4x1-47/40, 2-533TT(2), (2+4x2)-533TT(3)

	Hood	1	4	Hood	1920		46680t, 262.1x31.7x8.7m, 24b,4gt, 144000hp, 31kts, 1477p; 305belt, 178deck, 381turrets, 280CT; 4x2-381/42, 12x1-140/50, 4x1-102/45, 4x1-47/40, 6-533TT	
CBL	Courageous	1		Courageous	1917		22690t, 239.7x24.7x7.1m, 18b,4gt, 90000hp, 32kts, 828p; 76belt, 63deck, 229turrets, 254CT; 2x2-381/42, 6x3-102/45, 2x1-76/45, 2x1-47/40, (2+6x2)-533TT, 222m(2)	
		2		Glorious	1917			
MON	Abercrombie	1		Abercrombie	1915		6150t, 102.4x27.4x3.1m, 2b,2vqe(1,2)-2b,2vte(3), 2000(1,2)-1800(3)hp, 6-6.5kts, 198p; 102belt, 51deck, 254turret; 1x2-356/45, 1x1-152/40(3), 2x1-76/50, 2x1-76/45(2), 1x1-76/45(1,3), 1x1-47/50(1,3), 1x1-40/39(1), 2x1-40/39(3)	
		2		Havelock	1915			
		3		Roberts	1915			
	M29	2	4		M29	1915		580t, 54.0x9.4x1.8m, 2b,2vte, 400hp, 9kts, 72p; 152shields; 2x1-152/45, 1x1-76/45(5), 1x1-57/40(4)
			5		M33	1915		
	Lord Clive	1	6	Lord Clive	1915		6150t, 102.3x26.6x2.9m, 2b,2vte, 2310hp, 6.5kts, 194p; 152belt, 51deck, 267turret; 1x3-381/42, 1x2-305/35, 4x1-102/45, 2x1-76/45, 3x1-40/39	
	Marshal Soult	1	7	Marshal Soult	1915		6900t, 108.4x27.5x3.2m, 2d, 1500hp, 6kts, 187p; 102belt, 102deck, 330turret, 152CT; 1x2-381/42, 8x1-102/45, 2x1-76/50, 1x1-76/45, 1x1-47/50, 2x1-40/39	
	Erebus	2	8		Erebus	1916		8450t, 123.4x26.9x3.6m, 4b,2vte, 6000hp, 12kts, 204p; 102belt, 51deck, 330turret; 1x2-381/42, 8x1-102/45, 2x1-76/45, 2x1-76/40, 2x1-40/39
			9		Terror	1916		



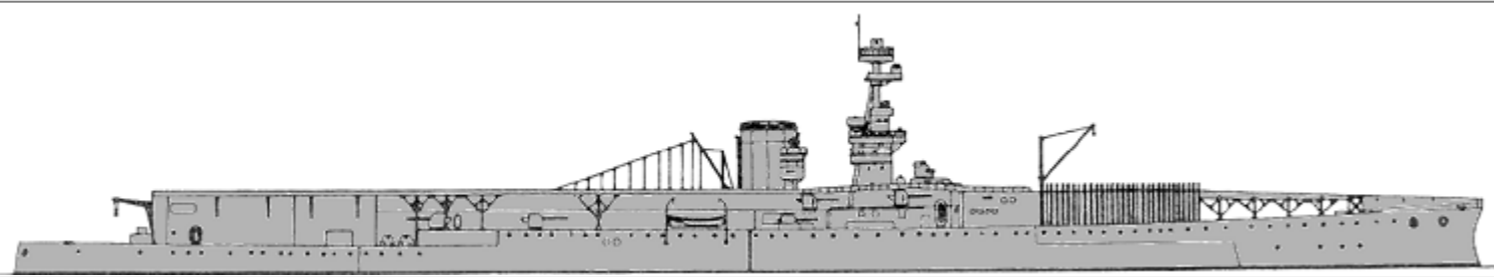
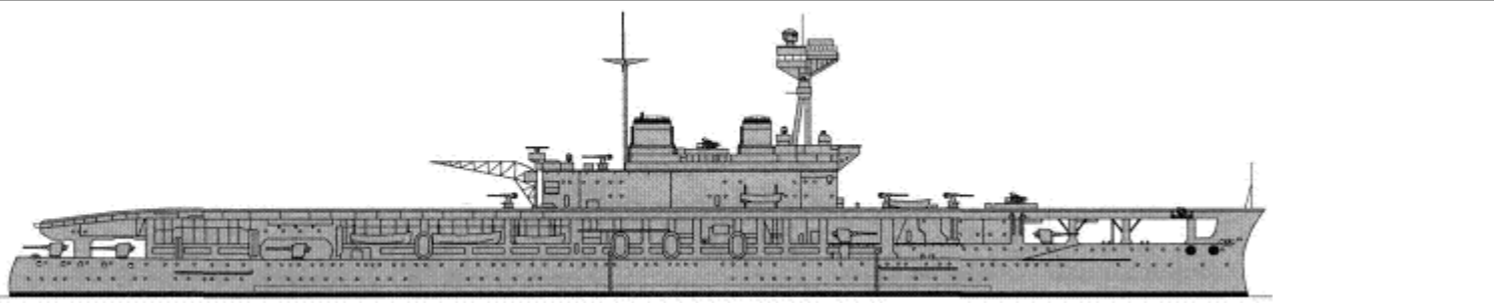
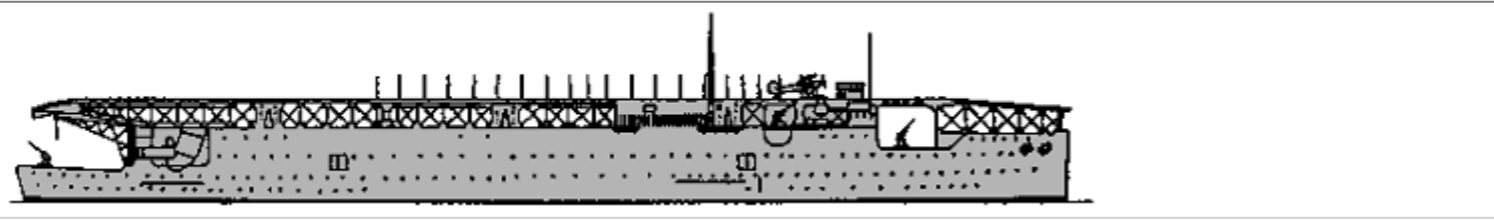
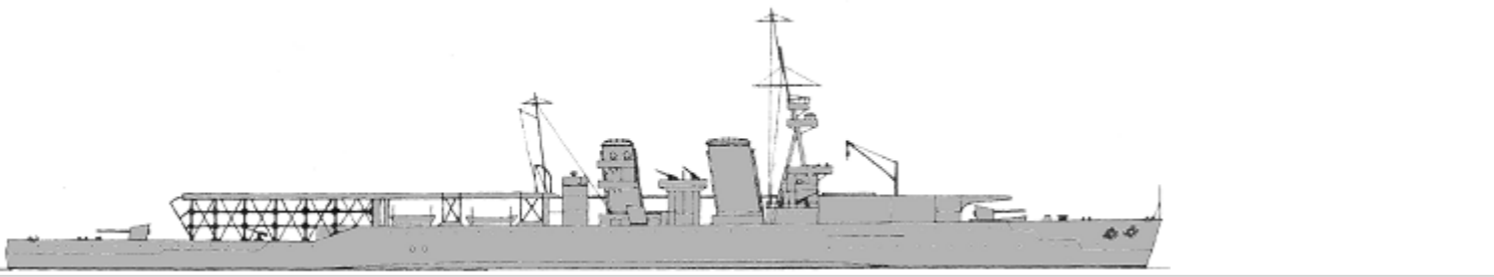
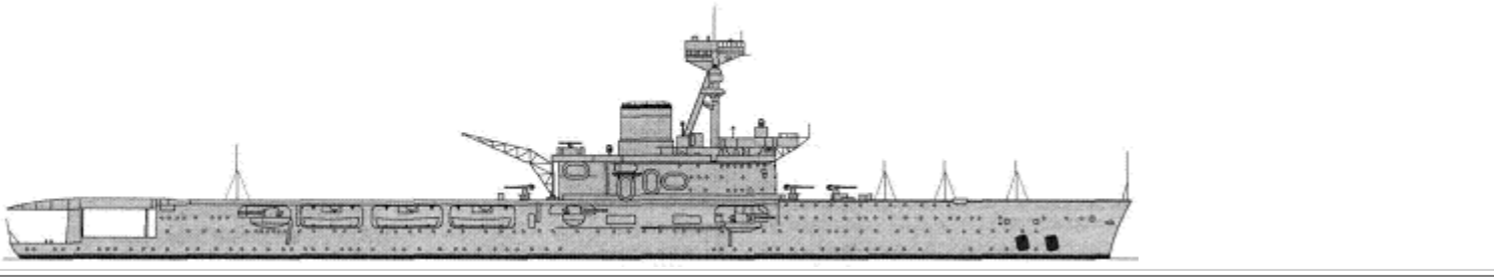

### AIRCRAFT CARRYING SHIPS

CV	Furious	1	1	Furious	1917		22890t, 239.7x26.8x6.4m, 18b,4gt, 90000hp, 31.5kts, 880p; 76belt, 76deck, 254CT; 10x1-140/50, 6x1-76/45, (2+4x3)-533TT, 20aircraft(4 Flycatcher I, 8 Dart II, 8 Fairey IIID)
	Eagle	1	2	Eagle	1923		26800t, 203.5x32.0x8.1m, 32b,4gt, 50000hp, 22.5kts, 950p; 114belt, 38deck, 76shields; 9x1-152/50, 4x1-102/45, 25aircraft (9 Flycatcher I, 12 Fairey IIID)
CVL	Argus	1	1	Argus	1918		15750t, 172.5x20.7x6.4m, 12b,4gt, 20000hp, 20kts, 401p; 51magazines; 6x1-102/45, 20aircraft(4 Flycatcher I, 10 Fairey IIID, 2 Walrus I)
	Vindictive	1	2	Vindictive	1918		12400t, 184.4x19.8x5.9m, 12b,4gt, 60000hp, 30kts, 560p; 76belt, 38deck, 76CT; 4x1-190/45, 4x1-76/50, 4x1-76/45, 6-533TT, 6aircraft (2 Flycatcher I, 4 Fairey IIID)
	Hermes	1	3	Hermes	1924		13700t, 182.3x21.4x5.7m, 6b,2gt, 40000hp, 25kts, 664p; 76belt, 25deck; 6x1-140/50, 3x1-102/45, 20aircraft (6 Flycatcher I, 9 Fairey IIID)
AV	Pegasus	1	1	Pegasus	1917	No picture	3300t, 101.2x13.1x4.6m, 6b,2gt, 9500hp, 20kts, 280p; 2x1-76/45, 2x1-76/40, 9aircraft (9 Fairey IIID)

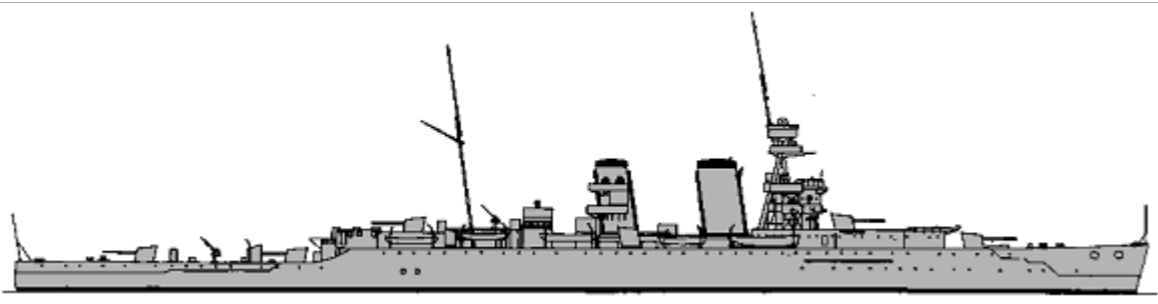
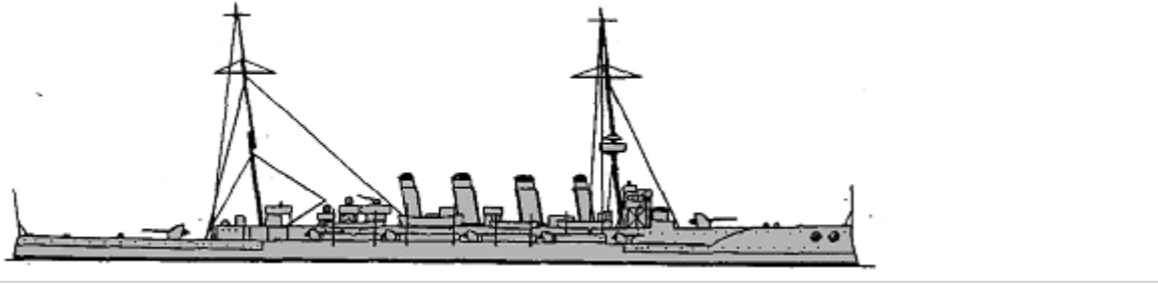
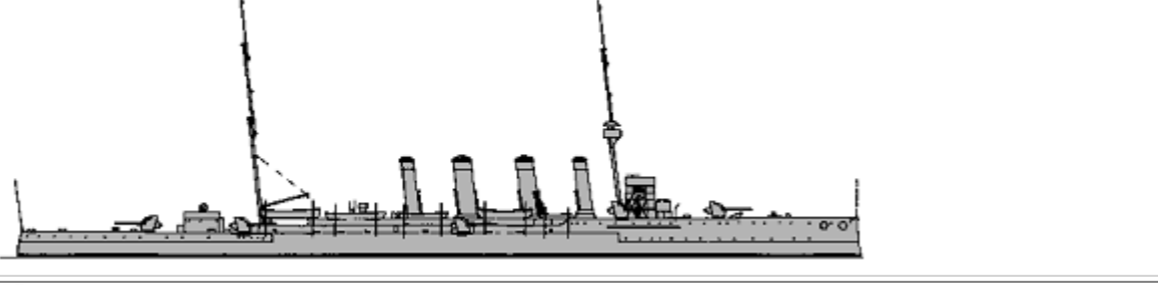
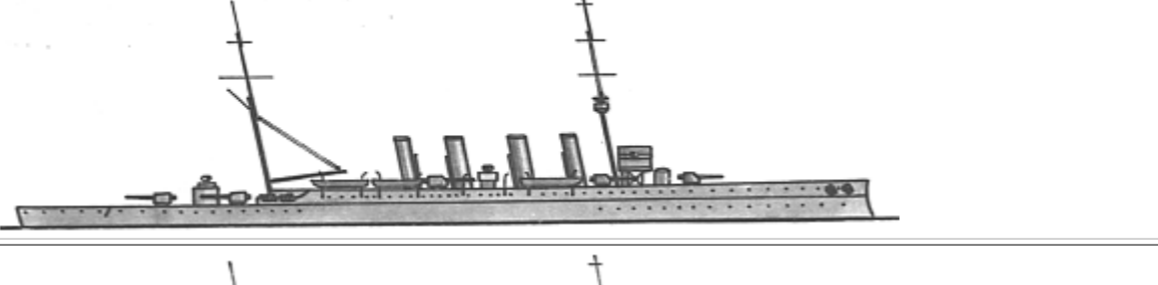
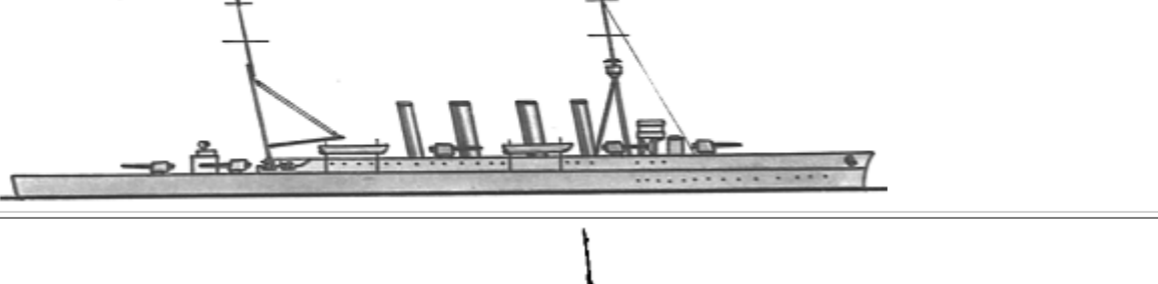
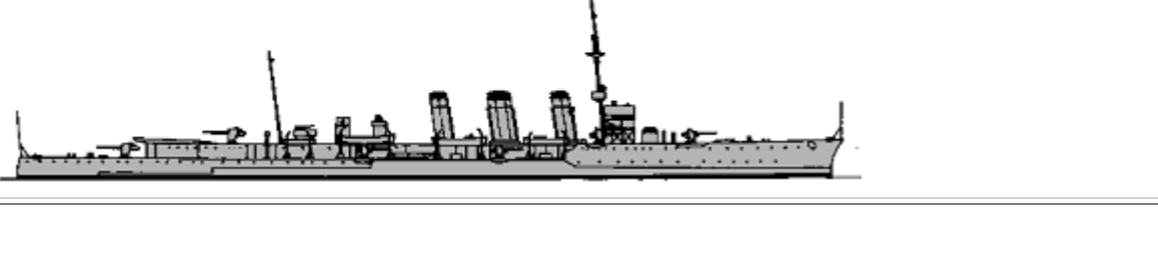

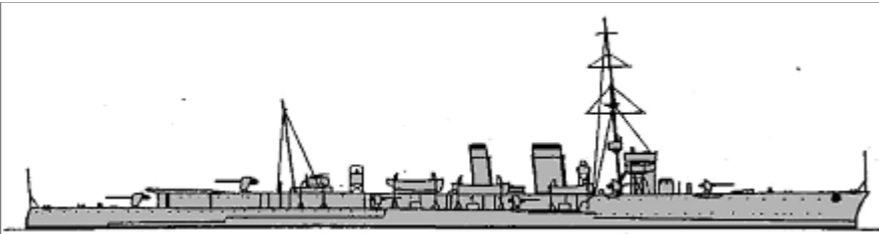
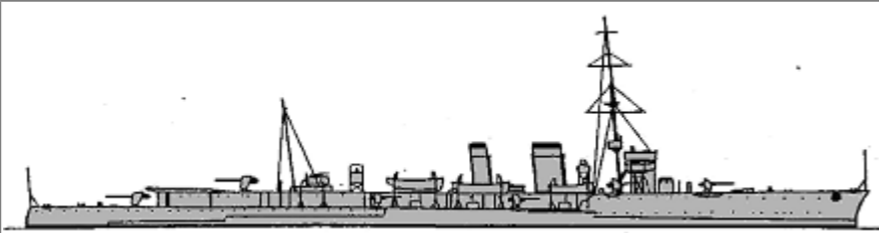
### CRUISERS

		1	Hawkins	1919		
--	--	---	---------	------	--	--

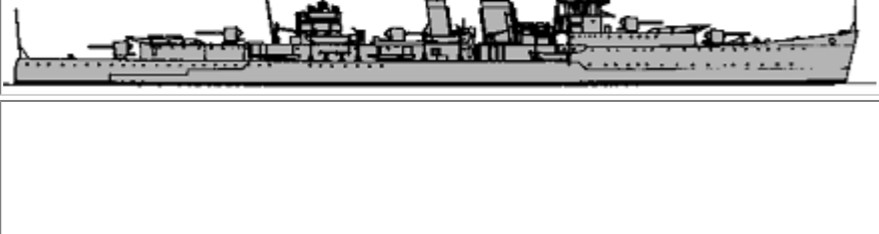

CA	Hawkins	2	2	Frobisher	1924		12300t, 184.4x19.8x5.9m, 12b(1)-10b(2),4gt, 60000(1)-65000(2)hp, 30(1)-30.5(2)kts, 712p; 76belt, 38deck, 51turrets, 76CT; 7x1-190/45, 2x1-102/45(1), 3x1-102/45(2), 4x1-47/40(1), 2x1-40/39, 6-533TT
	Bristol	1	1	Glasgow	1910		5300t, 138.1x14.3x4.7m, 12b,4t, 22000hp, 25kts, 480p; 51deck, 102shields, 51CT; 2x1-152/50, 10x1-102/40, 1x1-76/45, 4x1-47/40, 2-450TT
	Weymouth	2		Weymouth	1911		5800t, 138.1x14.6x4.7m, 12b, 4(2,3)-2(4)t, 22000hp, 25kts, 475p; 51deck, 102shields, 102CT(2,4); 8x1-152/50, 2x1-76/45(2,3), 1x1-76/45(4), 4x1-47/40, 2-533TT
		3		Dartmouth	1911		
		4		Yarmouth	1912		
	Chatham	5		Southampton	1912		6000t, 139.6x14.9x4.9m, 12b,2(5)-4(6)t, 25000hp, 25.5kts, 475p; 51belt, 38deck, 102shields; 8x1-152/45, 1x1-76/45, 4x1-47/40, 2-533TT
		6		Dublin	1913		
	Birmingham	7		Birmingham	1914		6100t, 139.3x15.2x4.9m, 12b,4t, 25000hp, 25.5kts, 480p; 51belt, 38deck, 102shields, 102CT; 9x1-152/45, 1x1-76/45, 4x1-47/40, 2-533TT
		8		Lowestoft	1914		
	Caroline	9		Carysfort	1915		4733t, 135.9x12.6x4.9m, 8b,4t, 40000hp, 28.5kts, 301p; 76belt, 25deck, 102shields; 4x1-152/45(9-11), 3x1-152/45(12), 2x1-102/45(10), 2x1-76/45(9,11,12), 4x1-47/40, 2x1-40/39, 4x2-533TT
		10		Cleopatra	1915		
		11		Comus	1915		
		12		Conquest	1915		
			13	Calliope	1915		

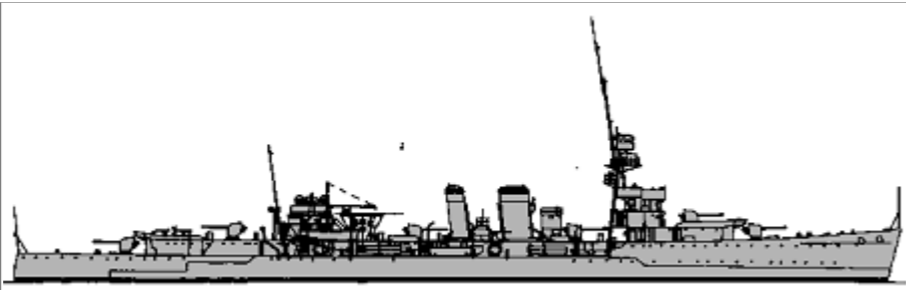
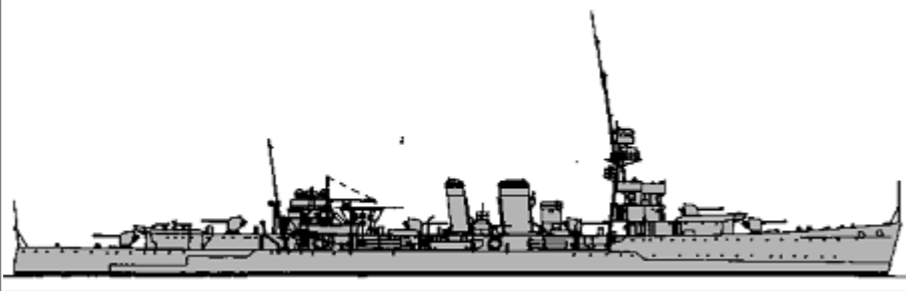



CL	Calliope	2	14	Champion	1915		4695t, 135.9x12.6x4.5m, 6b,4(13)-2(14)gt, 37500(13)-40000(14)hp, 29.5(13)-29(14)kts, 368p; 102belt, 25deck, 102shields, 152CT; 4x1-152/45, 2x1-76/45, 4x1-47/40, 2x1-40/39, 2-533TT
	Cambrian	4	15	Castor	1915		4799t, 135.9x12.6x4.5m, 6b,4gt, 40000hp, 28.5kts, 368p; 76belt, 25deck, 102shields, 152CT; 4x1-152/45, 2x1-76/45, 4x1-47/40, 2x1-40/39(15,17), 2-533TT
			16	Constance	1916		
			17	Cambrian	1916		
	Centaur	2	18	Canterbury	1916		4870t, 135.9x12.8x4.1m, 6b,4gt, 40000hp, 29kts, 437p; 76belt, 25deck, 102shields, 152CT; 5x1-152/45, 2x1-76/45, 2x1-40/39, 2-533TT
			19	Centaur	1916		
	Caledon	3	20	Concord	1916		4950t, 137.2x13.0x5.0m, 6b,2gt, 40000hp, 29kts, 400p; 76belt, 25deck, 25shields, 25CT; 5x1-152/45, 2x1-76/45, 4x1-47/40, 2x1-40/39, 4x2-533TT
			21	Caledon	1917		
			22	Calypso	1917		
	Ceres	5	23	Caradoc	1917		5020t, 137.2x13.3x4.5m, 6b,2gt, 40000hp, 29kts, 460p; 76belt, 25deck, 25shields, 25CT; 5x1-152/45, 2x1-76/45, 4x1-47/40, 2x1-40/39, 4x2-533TT
24			Ceres	1917			
25			Cardiff	1917			
26			Curlew	1917			
Carlisle	5	27	Curacoa	1918		5250t, 137.6x13.3x4.7m, 6b,2gt, 40000hp, 29kts, 432p; 76belt, 25deck, 25shields; 5x1-152/45, 2x1-76/45, 4x1-47/40, 2x1-40/39, 4x2-533TT	
		28	Coventry	1918			
		29	Carlisle	1918			
		30	Colombo	1919			
		31	Calcutta	1919			
Danae	3	32	Cairo	1919		5870t, 143.6x13.9x5.0m, 6b,2gt, 40000hp, 29kts, 460p; 76belt, 25deck, 25shields, 76CT; 6x1-152/45, 2x1-76/45, 2x1-40/39, 4x3-533TT	
		33	Capetown	1922			
		34	Danae	1918			
			35	Dragon	1918		
			36	Dauntless	1918		

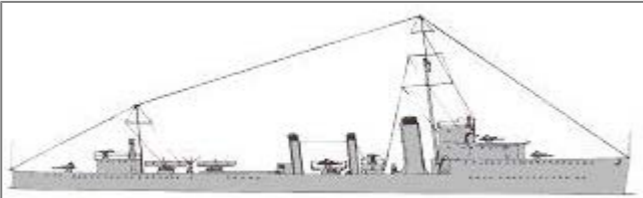
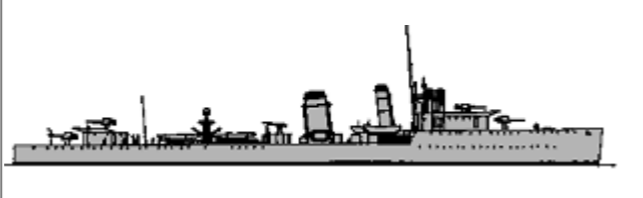



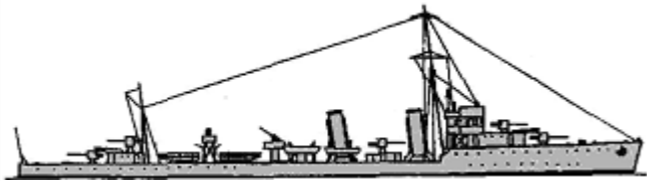

						
Delhi	4	37	Delhi	1919		5870t, 143.6x13.9x5.0m, 6b,2gt, 40000hp, 29kts, 460p; 76belt, 25deck, 25shields, 76CT; 6x1-152/45, 2x1-76/45, 2x1-40/39, 4x3-533TT
		38	Durban	1921		
		39	Despatch	1922		
		40	Diomedes	1922		
SL	Alert	1	Alert	1895		960t, 54.9x9.9x3.5m, b,1vte, 1400hp, 13.3kts, 106p; 6x1-102/40, 4x1-76/40, 2x1-11.4

TORPEDO SHIPS

DL	Lightfoot	2	1	Nimrod	1915		1700t, 99.0x9.7x3.7m, 4b,3t, 36000hp, 34.5kts, 104p; 4x1-102/40(1), 2x1-102/40(2), 2x1-40/39, 2x2-533TT(1), 2x1-450TT(1), 80m(2)
			2	Abdiel	1916		
	Parker	3	3	Grenville	1916		1912t, 99.0x9.7x3.7m, 4b,3t, 36000hp, 34kts, 116p; 4x1-102/40(3,5), 2x1-102/40(4), 2x1-40/39, 2x2-533TT(3,5), 80m(4)
			4	Seymour	1916		
			5	Saumarez	1916		
	V	5	6	Vampire	1917		1400t, 95.1x9.0x3.2m, 3b,2gt, 27000hp, 34kts, 115p; 4x1-102/45, 2x1-40/39, 2x3-533TT, 1DCR
			7	Valentine	1917		
			8	Valhalla	1917		
			9	Valorous	1917		
			10	Valkyrie	1917		
	Shakespeare	4	11	Shakespeare	1917		2000t, 100.3x9.6x3.8m, 4b,2gt, 40000hp, 36kts, 183p; 5x1-120/45, 1x1-76/45, 2x1-40/39, 2x3-533TT, 2DCT, 1DCR
			12	Spencer	1917		
			13	Wallace	1919		
			14	Keppel	1924		
				15	Bruce	1918	

Scott	7	16	Douglas	1918		2050t, 101.3x9.7x3.8m, 4b,2gt, 40000hp, 36kts, 164p; 5x1-120/45, 1x1-76/45, 2x1-40/39, 2x3-533TT, 2DCT, 1DCR
		17	Campbell	1918		
		18	Stuart	1918		
		19	Montrose	1918		
		20	Malcolm	1919		
		21	Mackay	1919		
M-Thornycroft	2	1	Rapid	1916		1130t, 83.7x8.4x2.6m, 3b,3t, 26500hp, 35kts, 80p; 3x1-102/40, 1x1-40/39, 2x2-533TT
		2	Ready	1916		
M-Yarrow	2	3	Relentless	1916		1008t, 82.2x7.9x2.6m, 3b,2t, 23000hp, 35kts, 80p; 3x1-102/40, 1x1-40/39, 2x2-533TT
		4	Rival	1916		
R-Admiralty	34	5	Radstock	1916		1244t, 84.1x8.1x2.7m, 3b,2gt, 27000hp, 36kts, 82p; 3x1-102/40, 1x1-40/39, 2x2-533TT, 2-356TT(some)
		6	Raider	1916		
		7	Romola	1916		
		8	Rowena	1916		
		9	Restless	1916		
		10	Rigorous	1916		
		11	Rocket	1916		
		12	Rob Roy	1916		
		13	Salmon	1916		
		14	Sarpedon	1916		
		15	Sable	1916		
		16	Sorceress	1916		
		17	Starfish	1916		
		18	Redgauntlet	1917		
		19	Redoubt	1917		
		20	Sturgeon	1917		
		21	Sceptre	1917		
		22	Sylph	1917		
23	Satyr	1917				
24	Sharpshooter	1917				
25	Skate	1917				
26	Stork	1917				
27	Skilful	1917				
28	Springbok	1917				
29	Tancred	1917				
30	Tarpon	1917				
31	Telemachus	1917				

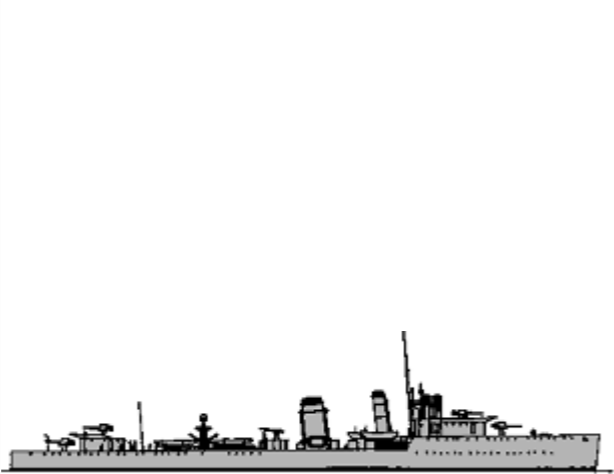
		32	Tempest	1917		
		33	Tetrarch	1917		
		34	Tenacious	1917		
		35	Thisbe	1917		
		36	Thruster	1917		
		37	Tormentor	1917		
		38	Torrid	1917		
R-Thornycroft	4	39	Rosalind	1916		1208t, 83.6x8.3x2.7m, 3b,2gt, 27000hp, 36kts, 82p; 3x1-102/40, 1x1-40/39, 2x2-533TT, 2-356TT(some)
		40	Retriever	1917		
		41	Taurus	1917		
		42	Teazer	1917		
R-Yarrow	4	43	Sabrina	1916		1051t, 83.4x7.8x2.7m, 3b,2t, 27000hp, 36kts, 82p; 3x1-102/40, 1x1-40/39, 2x2-533TT, 2-356TT(some)
		44	Sybille	1917		
		45	Truculent	1917		
		46	Tyrant	1917		
R-modified	8	47	Ulster	1917		1242t, 84.1x8.1x2.7m, 3b,2gt, 27000hp, 36kts, 82p; 3x1-102/45, 1x1-40/39, 2x2-533TT, 2-356TT(some)
		48	Undine	1917		
		49	Tower	1917		
		50	Trenchant	1917		
		51	Ursula	1917		
		52	Umpire	1917		
		53	Urchin	1917		
		54	Ursa	1917		
V-Admiralty	20	55	Vanquisher	1917		1523t, 95.1x9.0x3.2m, 3b,2gt, 27000hp, 34kts, 134p; 4x1-102/45 (can be 3x1-102/45 on 55,56,58,63,69,70,74), 1x1-40/39, 2x3-533TT(57,59-62,64-68,71-73), (1x3+1x2)-533TT(55,56,58,63,69,70,74) (can be 1x2-533TT on 55,56,58,63,69,70,74), 2DCT (or can be not on 55,56,58,63,69,70,74), 1DCR, MS, (can be 60m on 55,56,58,63,69,70,74)
		56	Vanoc	1917		
		57	Vega	1917		
		58	Venturous	1917		
		59	Vendetta	1917		
		60	Venetia	1917		
		61	Verdun	1917		
		62	Violent	1917		
		63	Vimiera	1917		
		64	Vivacious	1917		
		65	Vectis	1917		
		66	Vancouver	1918		
		67	Vanessa	1918		
		68	Vanity	1918		
		69	Velox	1918		
		70	Versatile	1918		
		71	Vesper	1918		

		72	Vidette	1918		
		73	Vivien	1918		
		74	Vortigern	1918		
V-Thornycroft	2	75	Viceroy	1918		1512t, 95.1x9.4x2.9m, 3b,2gt, 27000hp, 34kts, 134p; 4x1-102/45, 1x1-40/39, 2x3-533TT, 2DCT, 1DCR, MS
		76	Viscount	1918		
DD W-Admiralty	19	77	Wakeful	1917		1490t, 95.1x9.0x3.2m, 3b,2gt, 27000hp, 34kts, 134p; 4x1-102/45 (can be 3x1-102/45 on 78,81,83,85,88), 1x1-40/39, 2x3-533TT, (can be 1x3-533TT on 78,81,83,85,88), 2DCT (or can be not on 78,81,83,85,88), 1DCR, MS, (can be 60m on 78,81,83,85,88)
		78	Watchman	1918		
		79	Walpole	1918		
		80	Whitley	1918		
		81	Walker	1918		
		82	Westcott	1918		
		83	Walrus	1918		
		84	Wolfhound	1918		
		85	Warwick	1918		
		86	Wessex	1918		
		87	Voyager	1918		
		88	Whirlwind	1918		
		89	Wrestler	1918		
		90	Winchelsea	1918		
91	Winchester	1918				
92	Westminster	1918				
93	Windsor	1918				
94	Wryneck	1918				
95	Waterhen	1918				
W-Thornycroft	2	96	Wolsey	1918		1512t, 95.1x9.4x2.9m, 3b,2gt, 27000hp, 34kts, 134p; 4x1-102/45, 1x1-40/39, 2x3-533TT, 2DCT, 1DCR, MS
		97	Woolston	1918		
		98	Simoom	1918		
		99	Scimitar	1918		
		100	Scotsman	1918		
		101	Scout	1918		
		102	Shark	1918		
		103	Sparrowhawk	1918		
		104	Splendid	1918		
		105	Sabre	1918		
		106	Sikh	1918		
		107	Sirdar	1918		
		108	Somme	1918		





S-Admiralty	49	109	Senator	1918
		110	Sepoy	1918
		111	Seraph	1918
		112	Swallow	1918
		113	Tribune	1918
		114	Trinidad	1918
		115	Tactician	1918
		116	Tara	1918
		117	Scythe	1918
		118	Seabear	1918
		119	Seafire	1918
		120	Searcher	1918
		121	Sportive	1918
		122	Tilbury	1918
		123	Tintagel	1918
		124	Spear	1918
		125	Trojan	1918
		126	Saladin	1919
		127	Shamrock	1919
		128	Steadfast	1919
		129	Sterling	1919
		130	Seawolf	1919
		131	Sardonyx	1919
		132	Stormcloud	1919
		133	Spindrift	1919
		134	Serapis	1919
		135	Serene	1919
		136	Sesame	1919
		137	Strenuous	1919
		138	Stronghold	1919
		139	Sturdy	1919
		140	Truant	1919
		141	Trusty	1919
		142	Turbulent	1919
		143	Tenedos	1919
		144	Thanet	1919
		145	Thracian	1922
		146	Shikari	1924





1225t, 84.1x8.1x2.7m, 3b,2gt, 27000hp, 36kts, 90p; 3x1-102/40, 1x1-40/39, 2x2-533TT, 2DCT, 1DCR





S-Thornycroft	3	147	Torbay	1919
		148	Toreador	1919



1240t, 84.1x8.3x3.2m, 3b,2gt, 27000hp, 36kts, 90p; 3x1-102/40, 1x1-40/39, 2x2-533TT, 2x1-450TT, 2DCT, 1DCR

						
		149	Tourmaline	1919		
S-Yarrow	6	150	Torch	1918		1060t, 83.4x7.8x3.0m, 3b,2gt, 27000hp, 36kts, 90p; 3x1-102/40, 1x1-40/39, 2x2-533TT, 2DCT, 1DCR
		151	Tomahawk	1918		
		152	Tumult	1918		
		153	Turquoise	1919		
		154	Tuscan	1919		
		155	Tyrian	1919		
W-Modified	14	156	Vimy	1919		1508t, 95.1x9.0x3.2m, 3b,2gt, 27000hp, 34kts, 127p; 4x1-120/45, 2x1-40/39, 2x3-533TT, 2DCT, 1DCR
		157	Volunteer	1919		
		158	Venomous	1919		
		159	Verity	1919		
		160	Wanderer	1919		
		161	Veteran	1919		
		162	Whitshed	1919		
		163	Wild Swan	1919		
		164	Witherington	1919		
		165	Wivern	1919		
		166	Wolverine	1920		
		167	Worcester	1922		
		168	Wren	1923		
		169	Whitehall	1924		
W-Modified-Thornycroft	2	170	Wishart	1920		15030t, 95.1x9.4x2.9m, 3b,2gt, 30000hp, 35kts, 127p; 4x1-120/45, 2x1-40/39, 2x3-533TT, 2DCT, 1DCR
		171	Witch	1924		



SUBMARINES

E-II	2	1	E48	1917		667/807t, 55.6x4.6x3.8m, 2d/em, 1600/840hp, 15/9kts, 30p, 30m; 1x1-102/50(1), 1x1-76/50(2), 5-450TT(1), 3-450TT(2), 20m(2)
		2	E51	1917		
G	1	3	G4	1916		703/837t, 57.0x6.9x4.1m, 2d/em, 1600/840hp, 14.5/9kts, 30p, 30m; 1x1-76/45, 1-533TT, 4-450TT
K	6	4	K2	1917		1980/2566t, 100.6x8.1x5.2m, 2b,2gt/1dg/4em(2), 10500/700/1440hp, 24/9.5kts, 59p, 50m; 1x1-102/40, 1x1-76/45, 8-450TT
		5	K6	1917		
		6	K9	1917		
		7	K12	1917		
		8	K14	1917		
		9	K22	1917		



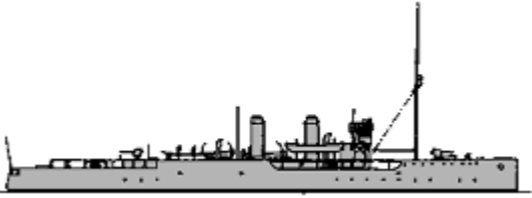

L-I	8	10	L1	1917		891/1074t, 70.4x7.2x4.0m, 2d/em, 2400/1600hp, 17/10.5kts, 35p, 50m; 1x1-102/40, 6-450TT
		11	L2	1917		
		12	L3	1918		
		13	L4	1918		
		14	L5	1918		
		15	L6	1918		
		16	L7	1917		
		17	L8	1918		
M	3	18	M1	1918		1594(18,19)-1633(20)/1946t, 90.2(18,19)-93.2(20)x7.5x4.9(18,19)-4.8(20)m, 2d/em, 2400/1600hp, 15/9kts, 65p, 30m; 1x1-305/40, 1x1-76/45, 4-533TT(3), 4-450TT(1,2)
		19	M2	1920		
		20	M3	1920		
H-II	21	21	H21	1918		423/510t, 52.4x4.8x4.0m, 2d/em, 480/620hp, 11.5/10.5kts, 22p, 30m; 4-533TT
		22	H22	1918		
		23	H23	1918		
		24	H24	1918		
		25	H25	1918		
		26	H26	1918		
		27	H27	1919		
		28	H28	1918		
		29	H29	1918		
		30	H30	1918		
		31	H31	1919		
		32	H32	1919		
		33	H33	1919		
		34	H34	1919		
		35	H43	1919		
		36	H44	1920		
		37	H47	1919		
		38	H48	1919		
		39	H49	1919		
		40	H50	1920		
		41	H52	1919		
R	2	42	R4	1919		410/503t, 49.9x4.6x3.5m, 1d/2em(1), 240/1200hp, 9.5/15kts, 22p, 75m; 6-450TT
		43	R10	1919		
L	6	44	L9	1918		
		45	L11	1918		
		46	L12	1918		
		47	L14	1918		
		48	L15	1918		
		49	L16	1918		

L-II	15	50	L17	1918		890/1080t, 72.7x7.2x4.0m, 2d/em, 2400/1600hp, 17/10.5kts, 38p, 50m; 1x1-102/40, 4-533TT, 2-450TT(44,48,49,51-56,58), 16m(45-47,50), 14m(57)
		51	L18	1919		
		52	L19	1919		
		53	L20	1919		
		54	L21	1920		
		55	L22	1921		
		56	L23	1924		
		57	L25	1920		
58	L33	1919				
L-III	5	59	L52	1921		960/1150t, 71.6x7.2x4.0m, 2d/em, 2400/1600hp, 17/10.5kts, 44p, 50m; 2x1-102/40, 6-533TT
		60	L54	1924		
		61	L56	1919		
		62	L69	1923		
		63	L71	1920		
K-II	1	64	K26	1923		2140/2530t, 107.0x8.5x4.9m, 2b,2gt/4em(2), 10500/1440hp, 23.5/9.5kts, 59p, 50m; 3x1-102/40, 6-533TT, 4-450TT

## ESCORTS

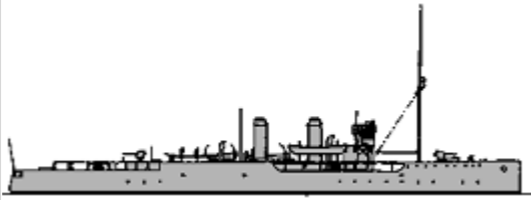
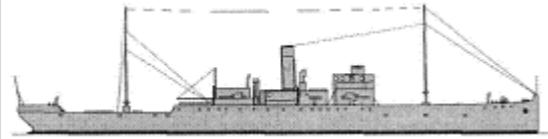
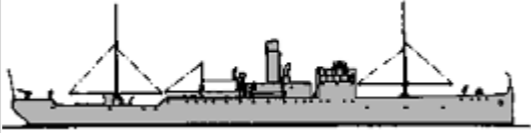

Acacia	9	1	Bluebell	1915		1275t, 80.0x10.1x3.4m, 2b,1vte, 1800hp, 16.5kts, 90p; 2x1-102/40, 2x1-40/39, 2DCT, 1DCR, MS	
		2	Daffodill	1915			
		3	Dahlia	1915			
		4	Foxglove	1915			
		5	Hollyhock	1915			
		6	Laburnum	1915			
		7	Lily	1915			
		8	Magnolia	1915			
		9	Veronica	1915			
Azalea	2	10	Clematis	1915		1275t, 80.0x10.1x3.4m, 2b,1vte, 1800hp, 16.5kts, 90p; 2x1-102/40, 2x1-47/50, 2DCT, 1DCR, MS	
		11	Heliotrope	1915			
SL	Arabis	12	12	Rosemary	1915		1350t, 81.7x10.2x3.4m, 2b,1vte, 2000hp, 16kts, 104p; 2x1-120/40 or 2x1-102/40, 2x1-47/50, 2DCT, 1DCR, MS
			13	Cornflower	1916		
			14	Crocus	1916		
			15	Cyclamen	1916		
			16	Delphinium	1916		
			17	Godetia	1916		
18	Lupin	1916					





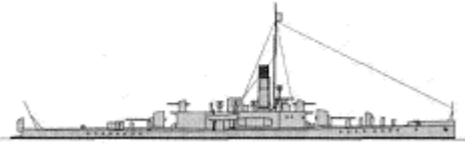

			19	Snapdragon	1916				
			20	Valerian	1916				
			21	Verbena	1916				
			22	Wallflower	1916				
			23	Wisteria	1916				
	Aubrietia	1	24	Heather	1916		1450t, 81.7x10.2x3.4m, 2b, 1vte, 2500hp, 17.5kts, 92p; 2x1-102/40, 1x1-47/50, 2DCT, 1DCR		
	Anchusa	5	25	Bryony	1917		1493t, 80.0x10.7x3.5m, 2b,1vte, 2500hp, 17.5kts, 119p; 2x1-102/40, 2x1-76/40, 2DCT, 2DCR		
				26	Sweetbriar			1917	
				27	Chrysanthemum			1918	
				28	Harebell			1918	
				29	Windflower			1918	
FS	P	6	1	P31	1916		613t, 74.5x7.2x2.4m, 2b,2t, 3500hp, 20kts, 54p; 1x1-102/40, 1x1-40/39, 3x1-356TT, 2DCR		
			2	P38	1917				
			3	P40	1916				
			4	P46	1917				
			5	P47	1917				
			6	P59	1917				
		PC	5	7	PC70	1918		780t, 75.3x8.2x2.4m, 2b,2t, 3500hp, 20kts, 55p; 1x1-102/40, 2x1-76/40, 2x1-356TT, 2DCR	
					8	PC71			1918
					9	PC72			1918
					10	PC73			1918
					11	PC74			1918
PC	Z	1	1	Cachalot	1915		346t, 40.5x7.6x2.6m, 2b,1vte, 1200hp, 13kts, 26p; 1x1-76/50, 2DCT		
AY	-	1	1	Alacrity	1900		1792brt		

OTHER FIGHTING SHIPS

PG	Bramble	2	1	Dwarf	1899		710t, 54.9x10.1x2.4m, 2b,2vte, 1300hp, 13kts, 85p; 2x1-102/40, 4x1-76/40
			2	Thistle	1900		
	Woodcock	2	1	Woodcock	1898	No picture	150t, 44.2x7.3x0.6m, 2b,1vte, 550hp, 13kts, 25p; 2x1-57/40
			2	Woodlark	1898		



PR	Moorhen	2	3	Moorhen	1901		180t, 48.7x7.5x0.8m, 2b,1vte, 670hp, 13kts, 35p; 2x1-57/40
			4	Teal	1901		
	Widgeon	1	5	Widgeon	1904		195t, 48.7x7.5x1.0m, 2b,1vte, 800hp, 12.5kts, 35p; 2x1-57/40
	Insect	12	6	Aphis	1915		750t, 72.4x11.0x1.2m, 2b,2vte, 2000hp, 14kts, 65p; 2x1-152/40(6-9,11-17), 1x1-152/40(10), 1x1-76/40
			7	Gnat	1915		
			8	Mantis	1915		
			9	Scarab	1915		
			10	Bee	1916		
			11	Cicala	1916		
			12	Cockchafer	1916		
			13	Cricket	1916		
			14	Glowworm	1916		
			15	Ladybird	1916		
	16	Moth	1916				
	17	Tarantula	1916				

### COASTAL FORCES





PT	CMB-40	8	1 - 8	CMB03 - 07, 09, 12, 13, 43, 44 - 46, 49, 51 - 61, 112, 121 - 123 (8 from)	1916 - 1920		5t, 13.7x2.6x0.8-0.9m, 1pe, 250-275hp, 24.8-37.8kts, 2-3p; 1-450TT
			9 - 28	CMB14A - 17A, 19A, 20A, 21B - 23B, 25BD, 26B, 27A - 29A, 30B, 31BD, 32A, 34A - 37A, 38B, 62BD - 64BD, 65A, 68B, 69A, 70A, 72A, 73B - 75B, 76A, 77A, 78E, 80C - 82C, 83CE, 84C, 85C, 86BD, 87B, 88BD - 92BD, 93E - 97E, 98ED, 113CK, 115DE, 116D, 117D, 120F (20 from)	1917 - 1922		11t, 18.3x3.4x0.9m, 2pe, 500-900hp, 35.1-41.2kts, 3-5p; 1-450TT or 2-450TT, 1DCR
			29 - 31	CMB102MT - 104MT	1919 - 1922		24t, 22.1x4.3x1.1m, 2pe, 1400hp, 36.6kts, 3-5p; 3-450TT or 7m, 1DCR
PS	ML	8	1 - 8	ML1 - 17, 20 - 37, 39, 41 - 51, 53, 54, 56 - 61, 63, 65 - 96, 99 - 109, 111 - 113, 118 - 120, 122 - 126, 128 - 148, 150, 151, 153 - 190, 192 - 195, 198 - 228, 231 - 246, 248 - 252, 256 - 277, 279 - 355, 357 - 389, 391, 393, 395, 397 - 399, 401, 405 - 420, 422, 423, 425 - 430, 432, 433, 435 - 441, 443, 445, 447, 455, 457, 461, 463, 465 - 468, 473, 475 - 488, 490, 494 - 520, 522 - 533, 535 - 539, 542, 545, 546, 549 - 560, 562 - 565, 567 - 580 (8 from)	1915 - 1918		34-37t, 22.9-24.4x3.7x1.2m, 2pe, 440hp, 19kts, 8p; 1x1-47/50 or 1x1-47/40, 2DCR, MS

### AMPHIBIOUS

			1	X21	1915		
			2	X23	1915		
			3	X31	1915		
			4	X36	1915		
			5	X38	1915		
			6	X45	1915		
			7	X64	1915		

LCU	X1	16	8	X69	1915		160t, 32.2x6.4x1.1m, 1sd, 60hp, 8kts; 500troops
			9	X95	1915		
			10	X103	1915		
			11	X111	1915		
			12	X131	1915		
			13	X134	1915		
			14	X140	1915		
			15	X149	1915		
	16	X178	1915				
	X201	7	17	X201	1916		137t, 29.6x6.1x1.1m, 1sd, 60hp, 8kts; 500troops
			18	X206	1916		
			19	X209	1916		
			20	X213	1916		
			21	X217	1916		
			22	X223	1916		
			23	X225	1916		
LCU(x)	DX	2	1	DX1	1916		137t, 29.6x6.1x1.1m; 500troops
			2	DX2	1916		

### MINE WARFARE

AML	-	3	1	Princess Margaret	1914		5934t, 120.5x16.5x5.1m, 2t, 15000hp, 22.5kts; 2x1-120/40, 2x1-76/40, 2x1-57/40, 500m
			2	Kate Lewis	1916		
			3	Strathcoe	1916		
Ascot		5	1	Atherstone	1916		810t, 74.9x17.7x2.1m, 2b,1dc, 1500hp, 14.5kts, 50p; 2x1-57/40, 2x1-40/39, MS
			2	Chelmsford	1916		
			3	Cheltenham	1916		
			4	Chepstow	1916		
			5	Melton	1916		
Hunt-I		1	6	Southdown	1917		870t, 70.4x8.5x2.1m, 2b,2vte, 1800hp, 16kts, 71p; 1x1-76/40, 1x1-57/40, MS
Banbury		1	7	Harpenden	1918		820t, 76.1x17.7x2.1m, 2b,1dc, 1500hp, 14.5kts, 52p; 2x1-57/40, 2x1-40/39, MS
			8	Aberdare	1918		
			9	Abingdon	1918		
			10	Badminton	1918		
			11	Burslem	1918		

MS



Hunt-II

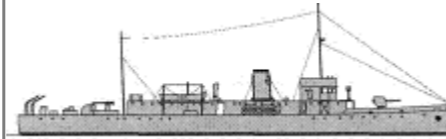

54

12	Derby	1918
13	Dorking	1918
14	Fareham	1918
15	Faversham	1918
16	Ford	1918
17	Gainsborough	1918
18	Gretna	1918
19	Harrow	1918
20	Kendal	1918
21	Leamington	1918
22	Mallaig	1918
23	Marlow	1918
24	Mistley	1918
25	Nailsea	1918
26	Newark	1918
27	Northolt	1918
28	Pangbourne	1918
29	Rugby	1918
30	Saltash	1918
31	Sherborne	1918
32	Shrewsbury	1918
33	Stoke	1918
34	Sutton	1918
35	Tiverton	1918
36	Tonbridge	1918
37	Tring	1918
38	Widnes	1918
39	Yeovil	1918
40	Albury	1919
41	Alresford	1919
42	Bagshot	1919
43	Carstairs	1919
44	Caterham	1919
45	Dundalk	1919
46	Dunoon	1919
47	Elgin	1919
48	Fermoy	1919
49	Forres	1919
50	Huntley	1919
51	Lydd	1919
52	Malvern	1919

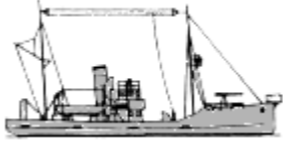

930t, 70.4x8.7x2.3m, 2b,2vte, 2200hp, 16kts, 74p; 1x1-102/40, 1x1-76/40, MS

			53	Marazion	1919		
			54	Petersfield	1919		
			55	Ross	1919		
			56	Saltburn	1919		
			57	Selkirk	1919		
			58	Stafford	1919		
			59	Tralee	1919		
			60	Truro	1919		
			61	Weybourne	1919		
TL	Mersey	11	1	Moy	1917		665t, 45.1x7.2x2.7m, 1b,1vte, 600hp, 11kts; 1x1-76/40, MS
			2	Ouse	1917		
			3	Doon	1917		
			4	Excellent	1918		
			5	Colne	1918		
			6	Cherwell	1918		
			7	Ettrick	1918		
			8	Exe	1918		
			9	Blackwater	1918		
			10	Boyne	1918		
			11	James Ludford	1919		
	Castle	18	12	TR1	1917		547t, 40.8x7.2x2.8m, 1b,1vte, 480hp, 10.5kts; 1x1-76/40, MS
			13	TR4	1918		
			14	TR7	1918		
			15	TR11	1918		
			16	TR13	1918		
			17	TR14	1918		
			18	TR19	1918		
			19	TR20	1918		
			20	TR23	1918		
			21	TR28	1918		
Strath	1	30	Itchen	1918	No picture	429t, 37.5x6.8x2.8m, 1b,1vte, 430hp, 10kts; 1x1-76/40, MS	
		31	Dee	1916			

	Axe	4	32	Garry	1916		520t, 42.3x7.2x3.7m, 1b,1vte, 490hp, 10.5kts, 20p; 1x1-76/40, MS
			33	Kennet	1916		
			34	Liffey	1916		
ATL	-	2	1	Flintshire	1916		
			2	Vernon	1916		215brt
DF	Admiralty steel	23	1	Billow	1918		200t, 28.4x5.7x2.2m, 1b,1vte, 270hp, 9kts; 1x1-57/40, MS
			2	Cascade	1918		
			3	Cloud	1918		
			4	Coldsnap	1918		
			5	Crescent Moon	1918		
			6	Eddy	1918		
			7	Flicker	1918		
			8	Glitter	1918		
			9	Halo	1918		
			10	Harmattan	1918		
			11	Horizon	1918		
			12	Indian Summer	1918		
			13	Landfall	1918		
			14	Leeward	1918		
			15	Levanter	1918		
			16	Lunar Bow	1918		
			17	Mist	1918		
			18	Noontide	1918		
			19	Sheen	1918		
			20	Shower	1918		
			21	Seabreeze	1919		
			22	Sundown	1919		
			23	Whirlpool	1920		
	Admiralty wooden	14	24	Iridescence	1917		175t, 28.7x6.1x2.2m, 1b,1vte, 270hp, 9kts; 1x1-57/40, MS
			25	Anticyclone	1918		
			26	Avalanche	1918		
			27	Black Frost	1918		
			28	Cirrus	1918		
			29	Fiery Cross	1918		
			30	Flat Calm	1918		
			31	Full Moon	1918		
			32	Midnight Sun	1918		
			33	Ray	1918		
			34	Shooting Star	1918		
			35	Silhouette	1918		

			36	Stormwrack	1918
			37	Fumarole	1919

### NAVAL AVIATION *(approximately, maximal number of delivered planes signed)*

Deck planes	F: 193 Flycatcher I <i>(delivery till 1930)</i> ; TB: 117 Dart II <i>(delivery till 1928)</i> ; R: 207 Fairey IIID <i>(mostly seaplanes, delivery till 1926)</i> , 36 Walrus I, 12 Bison IA, 30 Blackburn I
Seaplanes	R: 35 Fairey IIIC, 207 Fairey IIID <i>(partly wheeled, delivery till 1926)</i>

[home](#)[World navies yesterday](#)[1925](#)

## United States of America 01 January 1925

*IN SERVICE: 18 battleships, 1 aircraft carrier, 1 seaplane tender, 11 armoured cruisers, 8 protected cruisers, 3 scout cruisers, 9 light cruisers, 275 destroyers, 115 submarines, 52 patrol escorts, 9 armed patrol yachts, 8 gunboats, 2 river gunboats, 36 submarine chasers, 4 cruisers-minelayers, 14 destroyers-minelayers, 44 minesweepers, 20 Coast Guard destroyers, 6 Coast Guard submarine chasers, 22 Coast Guard cutters, 70 Coast Guard launches.*

### CAPITAL SHIPS AND MONITORS

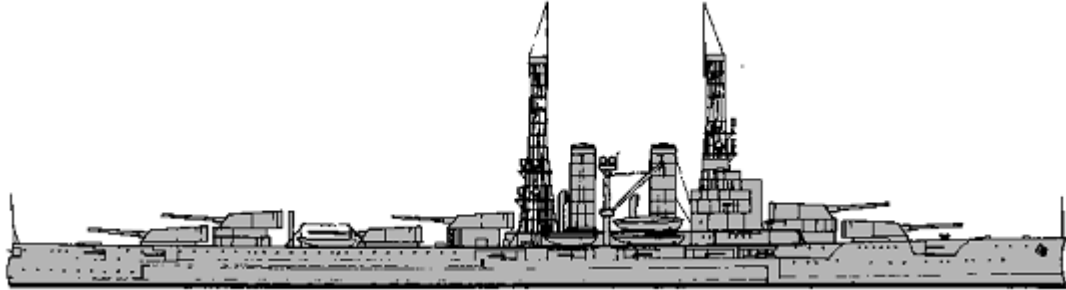
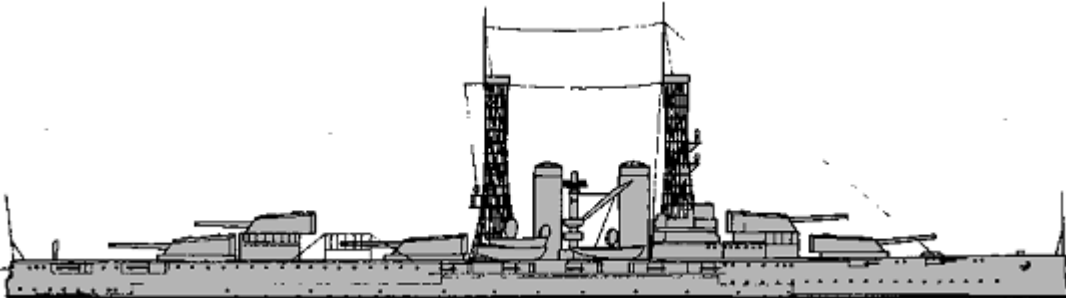
Florida	1	BB30	Florida	1911		23033t, 159.0x26.9x8.6m, 12b,4t, 28000hp, 20.8kts, 1001p; 280belt, 38deck, 305turrets, 292CT; 5x2-305/45, 16x1-127/51, 8x1-76/50, 2-533TT
	2	BB31	Utah	1911		
Wyoming	3	BB32	Wyoming	1912		27243t, 171.3x28.4x8.7m, 12b,4t, 28000hp, 20.5kts, 1063p; 280belt, 38deck, 305turrets, 292CT; 6x2-305/50, 16x1-127/51, 8x1-76/50, 2-533TT
	4	BB33	Arkansas	1912		
New York	5	BB34	New York	1914		28367t, 174.7x29.1x8.7m, 14b, 2vte, 28100hp, 21kts, 1042p; 305belt, 51deck, 356turrets, 305CT; 5x2-356/45, 16x1-127/51, 8x1-76/50, 4-533TT
	6	BB35	Texas	1914		
	7	BB36	Nevada	1916		



BB	Nevada	2	8	BB37	Oklahoma	1916		28400t, 177.7x29.1x8.7m, 12b, 2t(BB36)-2vte(BB37), 26500(BB36)-24800(BB37)hp, 20.5kts, 864p; 343belt, 76deck, 457-406turrets, 406CT; (2x3+2x2)-356/45, 21x1-127/51, 8x1-76/50, 2-533TT, 1seaplane(UO)
	Pennsylvania	2	9	BB38	Pennsylvania	1916		32567t, 185.4x29.6x8.8m, 12b, 4t, 31500hp, 21kts, 915p; 343belt, 76deck, 457turrets, 406CT; 4x3-356/45, 22x1-127/51, 8x1-76/50, 2-533TT
			10	BB39	Arizona	1916		
	New Mexico	3	11	BB40	New Mexico	1918		33000t, 190.2x29.7x9.1m, 9b, (2tg,4em) (BB40)-4t(BB41,42), 27500(BB40)-32000(BB41,42)hp, 21kts, 1084p; 343belt, 89deck, 457turrets, 406CT; 4x3-356/50, 12x1-127/51, 8x1-76/50, 2-533TT
			12	BB41	Mississippi	1917		
			13	BB42	Idaho			
Tennessee	2	14	BB43	Tennessee	1920		33190t, 190.2x29.7x9.2m, 8b,2tg,4em, 26800hp, 21kts, 1083p; 343belt, 89deck, 457turrets, 406CT; 4x3-356/50, 12x1-127/51, 8x1-76/50, 2-533TT, 1seaplane(UO)	
		15	BB44	California	1921			
Colorado	3	16	BB45	Colorado	1923		33590t, 190.2x29.7x9.2m, 8b,2tg,4em, 28900hp, 21kts, 1080p; 343belt, 89deck, 457turrets, 406CT; 4x2-406/45, 12x1-127/51, 8x1-76/50, 2-533TT, 1seaplane(UO,17)	
		17	BB46	Maryland	1921			
		18	BB48	West Virginia	1923			

### AIRCRAFT CARRYING SHIPS

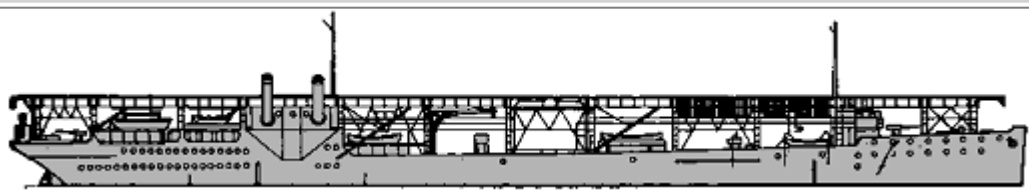
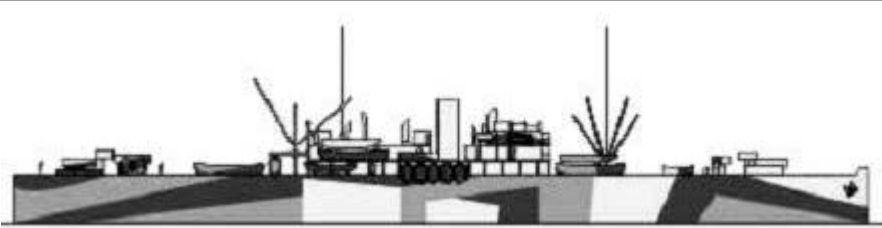
CV	Langley	1	1	CV1	Langley	1913		15150t, 165.3x19.9x6.3m, 3b,2tg,2em, 6500hp, 15.5kts, 468p; 4x1-127/51, 34aircraft(12 TS, 12 UO, 4 SC, 6 UO w/floats)
AV	Wright	1	1	AV1	Wright	1921		11500t, 136.6x17.7x7.0m, 6b,1t, 6000hp, 15kts, 228p; 2x1-127/51, 2x1-76/50, 12seaplanes (12 UO)



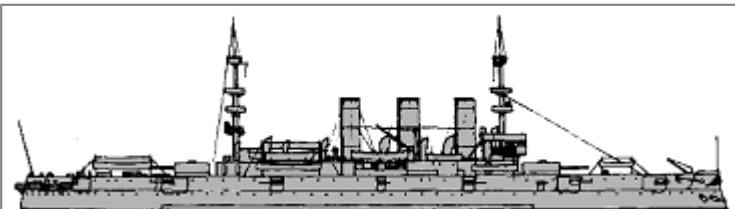
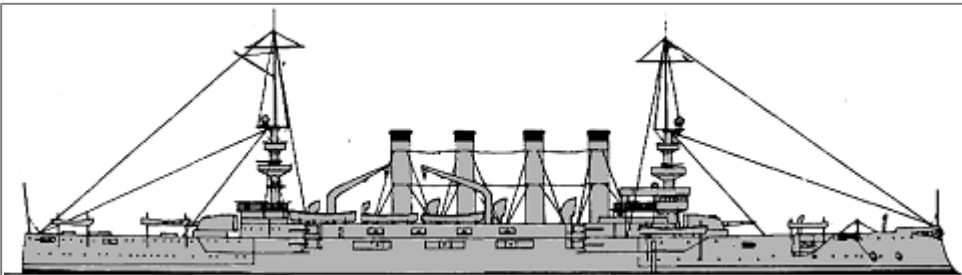
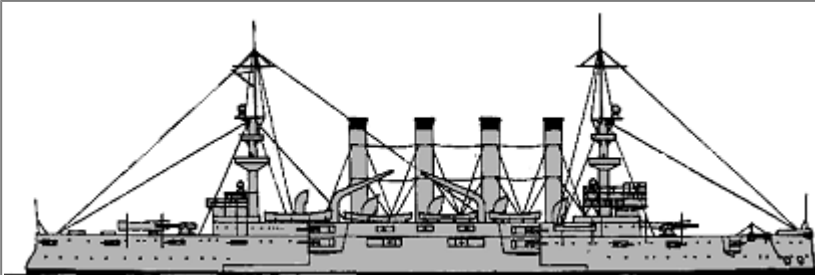
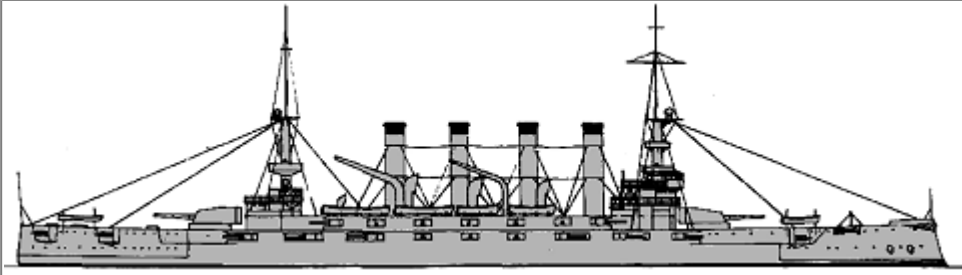

### CRUISERS

CA	New York	1	1	CA2	Rochester	1893		9021t, 117.0x19.8x7.3m, 12b,4vte(2), 16000hp, 20kts, 566p; 102belt, 152deck, 165turrets, 190CT; 2x2-203/45, 8x1-127/50, 2x1-76/50
	Pennsylvania	2	CA4	Pittsburgh	1905		15138t, 153.6x21.2x7.3m, 12b(2)-16b(3-6), 2vte, 17000(2)-23000(3-6)hp, 22kts, 928p; 152belt, 102deck, 165turrets, 229CT; 2x2-203/45, 14x1-152/50, 12x1-76/50, 12x1-47/40, 2x1-37/50, 2-450TT	
		3	CA5	Huntington	1905			
		4	CA7	Pueblo	1905			
		5	CA8	Frederick	1905			
	6	CA9	Huron	1908				
	St. Louis	2	7	CA18	St. Louis	1906		10839t, 129.9x20.1x6.9m, 16b,2vte, 21000hp, 22kts, 767p; 102belt, 76deck, 102casemates, 127CT; 12x1-152/50, 6x1-76/50
	8	CA19	Charleston	1905				
	Tennessee	9	CA11	Seattle	1906		15715-15981t, 153.8x22.2x7.6m, 16b,2vte, 23000hp, 22kts, 914p; 127belt, 102deck, 229turrets, 229CT; 2x2-254/40, 16x1-152/50, 14x1-76/50, 4-533TT	
		10	CA12	Charlotte	1908			
		11	CA13	Missoula	1908			

CL	Olympia	1	1	CL15	Olympia	1895		6558t, 104.9x16.2x6.6m, 6b,2vte, 13500hp, 20kts, 447p; 51deck, 89turrets, 102shields, 127CT; 10x1-127/51
	New Orleans	2	2	CL22	New Orleans	1898		4011t, 108.0x13.3x5.5m, 4b,2vte, 7500hp, 20kts, 366p; 32deck, 102CT; 8x1-127/50, 3-450TT
		3	3	CL23	Albany	1900		
	Denver	4	4	CL16	Denver	1904		3514t, 94.1x13.4x4.8m, 6b,2vte, 4500hp, 16.5kts, 339p; 8deck, 44casemates; 8x1-127/50
		5	5	CL17	Des Moines	1904		
		6	6	CL18	Chattanooga	1904		
		7	7	CL19	Galveston	1905		
	Chester	8	8	CL21	Cleveland	1903		4687t, 129.0x14.3x5.1m, 12b, 4t(9)-2vte(10)-2gt(11), 16000(9,10)-20000(11)hp, 24(9,11)-22.4(10)kts, 359p; 51belt, 25deck; 4x1-127/51, 3x1-76/50, 2-533TT
		9	9	CL1	Chester	1908		
		10	10	CL2	Birmingham	1908		
	Omaha	11	11	CL3	Salem	1908		9508t, 169.4x16.9x4.1m, 12b,4gt, 90000hp, 34kts, 458p; 76belt, 38deck, 32CT; (2x2+8x1)-152/53, 4x1-76/50, (2x3+2x2)-533TT, 2seaplanes(UO)
		12	12	CL4	Omaha	1923		
		13	13	CL5	Milwaukee	1923		
		14	14	CL6	Cincinnati	1924		
		15	15	CL7	Raleigh	1924		
		16	16	CL8	Detroit	1923		
		17	17	CL9	Richmond	1923		
		18	18	CL10	Concord	1923		
		19	19	CL11	Trenton	1924		
	20	20	CL12	Marblehead	1924			

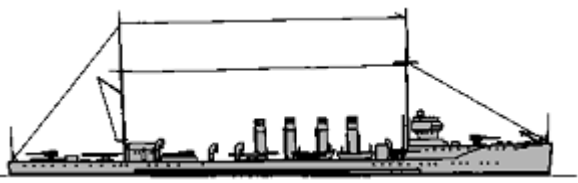
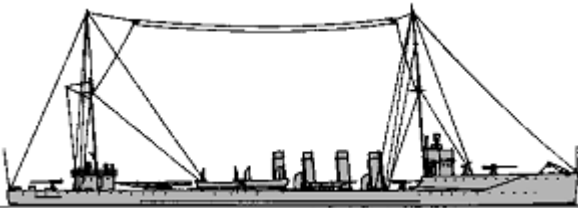
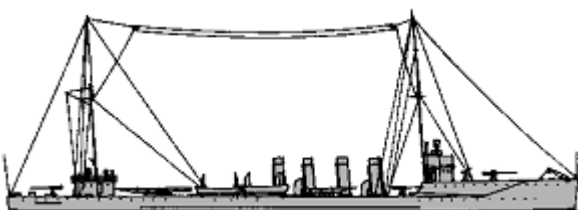
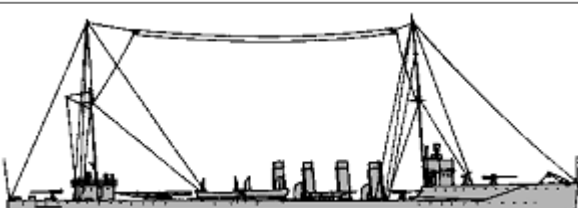
### TORPEDO SHIPS

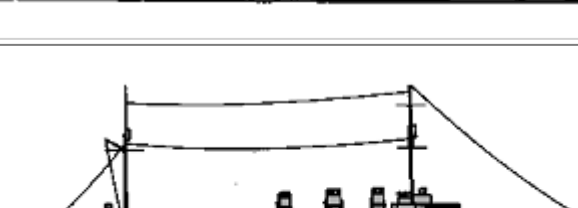
Paulding	5	1	DD23	Drayton	1910		887t, 89.6x8.0x2.4m, 4b,3t(1)-2t(2-5), 12000(1)-10000(2-4)-13000(5)hp, 29.5(1,5)-28(2-4)kts, 86p; 5x1-76/50, 3x2-450TT, 1DCT, 2DCR
		2	DD26	Perkins	1910		
		3	DD27	Sterett	1910		
		4	DD30	Warrington	1911		
		5	DD31	Mayrant	1911		
		6	DD34	Walke	1911		

Monaghan	3	7	DD38	Jarvis	1912		883t, 89.5x8.2x2.5m, 4b,2t(6)-3t(7,8), 10000(6)-12000(7,8)hp, 28(6)-29.5(7,8)kts, 89p; 5x1-76/50, 3x2-450TT, 1DCT, 2DCR
		8	DD42	Jenkins			
Cassin	5	9	DD46	Duncan	1913		1235t, 93.1x9.2x3.0m, 4b,2t, 16000hp, 29kts, 98p; 4x1-102/50, 4x2-450TT, 1DCT, 2DCR
		10	DD47	Aylwin	1914		
		11	DD48	Parker	1913		
		12	DD49	Benham	1914		
		13	DD50	Balch	1914		
O'Brien	4	14	DD51	O'Brien	1915		1171t, 93.1x9.5x2.9m, 4b,2t, 17000hp, 29kts, 101p; 4x1-102/50, 4x2-533TT, 1DCT, 2DCR
		15	DD52	Nicholson	1915		
		16	DD53	Winslow	1915		
		17	DD55	Cushing	1915		
Tucker	3	18	DD57	Tucker	1916		1205t, 96.1x9.1x2.9(18,20)-2.8(19)m, 4b,2t(18,20)-2gt(19), 17000(18,20)-17500(19)hp, 29.5kts, 99p; 4x1-102/50, 4x2-533TT, 1DCT, 2DCR
		19	DD60	Wadsworth	1915		
		20	DD62	Wainwright	1916		
Sampson	6	21	DD63	Sampson	1916		1225t, 96.1x9.1x2.9m, 4b,2t, 17500hp, 29.5kts, 99p; 4x1-102/50, 1x1-37/40, 4x3-533TT, 1DCT, 2DCR
		22	DD64	Rowan	1916		
		23	DD65	Davis	1916		
		24	DD66	Allen	1917		
		25	DD67	Wilkes	1916		
		26	DD68	Shaw	1917		
Caldwell	6	27	DD69	Caldwell	1917		1187t, 96.2x9.3x2.7m, 4b, 2gt(27-29,32)-3t(30,31), 18500hp, 30kts, 100p; 4x1-102/50, 2x1-76/23, 4x3-533TT, 1DCT, 2DCR
		28	DD70	Craven	1918		
		29	DD71	Gwin	1920		
		30	DD72	Conner	1918		
		31	DD73	Stockton	1917		
		32	DD74	Manley	1917		
		33	DD75	Wickes	1918		
		34	DD76	Philip	1918		
		35	DD78	Evans	1918		
		36	DD79	Little	1918		
		37	DD80	Kimberly	1918		
		38	DD81	Sigourney	1918		
		39	DD82	Gregory	1918		
		40	DD83	Stringham	1918		

41	DD84	Dyer	1918
42	DD85	Colhoun	1918
43	DD86	Stevens	1918
44	DD87	McKee	1918
45	DD88	Robinson	1918
46	DD89	Ringgold	1918
47	DD90	McKean	1919
48	DD91	Harding	1919
49	DD92	Gridley	1919
50	DD93	Fairfax	1918
51	DD94	Taylor	1918
52	DD95	Bell	1918
53	DD103	Schley	1918
54	DD104	Champlin	1918
55	DD105	Mugford	1918
56	DD106	Chew	1918
57	DD107	Hazelwood	1919
58	DD108	Williams	1919
59	DD109	Crane	1919
60	DD113	Rathburne	1918
61	DD114	Talbot	1918
62	DD115	Waters	1918
63	DD116	Dent	1918
64	DD117	Dorsey	1918
65	DD118	Lea	1918
66	DD119	Lamberton	1918
67	DD120	Radford	1918
68	DD121	Montgomery	1918
69	DD122	Breese	1918
70	DD123	Gamble	1918
71	DD124	Ramsay	1919
72	DD125	Tattnall	1919
73	DD126	Badger	1919
74	DD127	Twiggs	1919
75	DD128	Babbitt	1919
76	DD130	Jacob Jones	1919
77	DD131	Buchanan	1919
78	DD132	Aaron Ward	1919
79	DD133	Hale	1919
80	DD134	Crowninshield	1919
81	DD135	Tillman	1920

Wickes

94

1247t, 95.8x9.4x2.8m, 4b,2t, 27000(33-71,77-102,107-127)-24900(72-76)-26000(103-106)hp, 35kts, 114p; 4x1-102/50, 2x1-76/23, 4x3-533TT, 1DCT, 2DCR

82	DD136	Boggs	1918
83	DD137	Kilty	1918
84	DD138	Kennison	1919
85	DD139	Ward	1919
86	DD140	Claxton	1919
87	DD141	Hamilton	1919
88	DD142	Tarbell	1918
89	DD143	Yarnall	1918
90	DD144	Upshur	1918
91	DD145	Greer	1918
92	DD146	Elliot	1919
93	DD147	Roper	1919
94	DD148	Breckinridge	1919
95	DD149	Barney	1919
96	DD150	Blakeley	1919
97	DD151	Biddle	1919
98	DD152	Du Pont	1919
99	DD153	Bernadou	1919
100	DD154	Ellis	1919
101	DD155	Cole	1919
102	DD156	J. Fred Talbot	1919
103	DD157	Dickerson	1919
104	DD158	Leary	1919
105	DD159	Schenck	1919
106	DD160	Herbert	1919
107	DD161	Palmer	1918
108	DD162	Thatcher	1919
109	DD163	Walker	1919
110	DD164	Crosby	1919
111	DD165	Meredith	1919
112	DD166	Bush	1919
113	DD167	Cowell	1919
114	DD168	Maddox	1919
115	DD169	Foote	1919
116	DD170	Kalk	1919
117	DD175	Mackenzie	1919

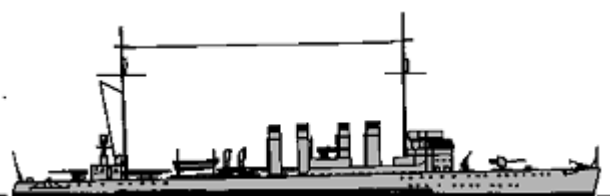

118	DD176	Renshaw	1919
119	DD177	O`Bannon	1919
120	DD178	Hogan	1919
121	DD179	Howard	1920
122	DD180	Stansbury	1920
123	DD181	Hopewell	1919
124	DD182	Thomas	1919
125	DD183	Haraden	1919
126	DD184	Abbot	1919
127	DD185	Bagley	1919
128	DD186	Clemson	1919
129	DD187	Dahlgren	1920
130	DD188	Goldsborough	1920
131	DD189	Semmes	1920
132	DD190	Satterlee	1919
133	DD191	Mason	1920
134	DD193	Abel P. Upshur	1920
135	DD194	Hunt	1920
136	DD195	Welborn C. Wood	1921
137	DD196	George E. Badger	1920
138	DD197	Branch	1920
139	DD198	Herndon	1920
140	DD199	Dallas	1920
141	DD206	Chandler	1919
142	DD207	Southard	1919
143	DD208	Hovey	1919
144	DD209	Long	1919
145	DD210	Broome	1919
146	DD211	Alden	1919
147	DD212	Smith Thompson	1919
148	DD213	Barker	1919
149	DD214	Tracy	1920
150	DD215	Borie	1920
151	DD216	John D. Edwards	1920
152	DD217	Whipple	1920
153	DD218	Parrott	1920
154	DD219	Edsall	1920

DD

155	DD220	MacLeish	1920
156	DD221	Simpson	1920
157	DD222	Bulmer	1920
158	DD223	McCormick	1920
159	DD224	Stewart	1920
160	DD225	Pope	1920
161	DD226	Peary	1920
162	DD227	Pillsbury	1920
163	DD228	John D. Ford	1920
164	DD229	Truxtun	1921
165	DD230	Paul Jones	1921
166	DD231	Hatfield	1920
167	DD232	Brooks	1920
168	DD233	Gilmer	1920
169	DD234	Fox	1920
170	DD235	Kane	1920
171	DD236	Humphreys	1920
172	DD237	McFarland	1920
173	DD238	James K. Paulding	1920
174	DD239	Overton	1920
175	DD240	Sturtevant	1920
176	DD241	Childs	1920
177	DD242	King	1920
178	DD243	Sands	1920
179	DD244	Williamson	1920
180	DD245	Reuben James	1920
181	DD246	Bainbridge	1921
182	DD247	Goff	1921
183	DD248	Barry	1920
184	DD249	Hopkins	1921
185	DD250	Lawrence	1921
186	DD251	Belknap	1919
187	DD252	McCook	1919
188	DD253	McCalla	1919
189	DD254	Rodgers	1919
190	DD255	Osmond Ingram	1919
191	DD256	Bancroft	1919
192	DD257	Welles	1919



Clemson 148

193	DD258	Aulick	1919
194	DD259	Turner	1919
195	DD260	Gillis	1919
196	DD262	McDermut	1919
197	DD263	Laub	1919
198	DD264	McLanahan	1919
199	DD265	Edwards	1919
200	DD266	Greene	1919
201	DD267	Ballard	1919
202	DD268	Shubrick	1919
203	DD269	Bailey	1919
204	DD270	Thornton	1919
205	DD271	Morris	1919
206	DD272	Tingey	1919
207	DD273	Swasey	1919
208	DD274	Meade	1919
209	DD275	Sinclair	1919
210	DD276	McCawley	1919
211	DD277	Moody	1919
212	DD278	Henshaw	1919
213	DD279	Meyer	1919
214	DD280	Doyen	1919
215	DD281	Sharkey	1919
216	DD282	Toucey	1919
217	DD283	Breck	1919
218	DD284	Isherwood	1919
219	DD285	Case	1919
220	DD286	Lardner	1919
221	DD287	Putnam	1919
222	DD288	Worden	1920
223	DD289	Flusser	1920
224	DD290	Dale	1920
225	DD291	Converse	1920
226	DD292	Reid	1919
227	DD293	Billingsley	1920
228	DD294	Charles Ausburn	1920
229	DD295	Osborne	1920
230	DD298	Percival	1920
231	DD299	John Francis Burnes	1920

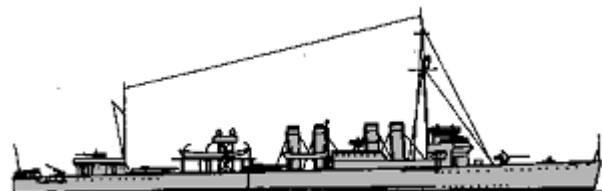







1308t, 95.8x9.4x3.0m, 4b,2gt, 27000hp, 35kts, 114p; 4x1-127/51(166-170), 4x1-102/50(128-142,145-165,171-275), 4x2-102/50(143,144), 2x1-76/23, 4x3-533TT, 1DCT, 2DCR





232	DD300	Farragut	1920
233	DD301	Somers	1920
234	DD302	Stoddert	1920
235	DD303	Reno	1920
236	DD304	Farquhar	1920
237	DD305	Thompson	1920
238	DD306	Kennedy	1920
239	DD307	Paul Hamilton	1920
240	DD308	William Jones	1920
241	DD313	Zeilin	1920
242	DD314	Yarborough	1920
243	DD315	La Vallette	1920
244	DD316	Sloat	1920
245	DD317	Wood	1921
246	DD318	Shirk	1921
247	DD319	Kidder	1921
248	DD320	Selfridge	1921
249	DD321	Marcus	1921
250	DD322	Mervine	1921
251	DD323	Chase	1921
252	DD324	Robert Smith	1921
253	DD325	Mullany	1921
254	DD326	Coghlan	1921
255	DD327	Preston	1921
256	DD328	Lamson	1921
257	DD329	Bruce	1921
258	DD330	Hull	1921
259	DD331	MacDonough	1921
260	DD332	Farenholt	1921
261	DD333	Sumner	1921
262	DD334	Corry	1921
263	DD335	Melvin	1921
264	DD336	Litchfield	1920
265	DD337	Zane	1921
266	DD338	Wasmuth	1921
267	DD339	Trever	1922
268	DD340	Perry	1922
269	DD341	Decatur	1922
270	DD342	Hulbert	1920
271	DD343	Noa	1921
		William B.	

272	DD344	Preston	1920
273	DD345	Preble	1920
274	DD346	Sicard	1920
275	DD347	Pruitt	1920

## SUBMARINES

H1	8	1	SS29	H2	1913		358/467t, 45.8x4.8x3.8m, 2d/em, 950/600hp, 14/10.5kts, 25p, 60m; 4-450TT
		2	SS30	H3	1914		
		3	SS147	H4	1918		
		4	SS148	H5	1918		
		5	SS149	H6	1918		
		6	SS150	H7	1918		
		7	SS151	H8	1918		
		8	SS152	H9	1918		
K	8	9	SS32	K1	1914		392/521t, 46.9x5.1x4.0m, 2d/em, 950/680hp, 14/10.5kts, 28p, 60m; 4-450TT
		10	SS33	K2	1914		
		11	SS34	K3	1914		
		12	SS35	K4	1914		
		13	SS36	K5	1914		
		14	SS37	K6	1914		
		15	SS38	K7	1914		
		16	SS39	K8	1914		
L	4	17	SS41	L2	1916		450/548t, 51.0x5.3x4.1m, 2d/em, 1200/800hp, 14/10.5kts, 28p, 60m; 4-450TT
		18	SS42	L3	1916		
		19	SS49	L9	1916		
		20	SS51	L11	1916		
N	3	21	SS53	N1	1917		348/414t, 44.9x4.8x3.8m, 2d/em, 600/300hp, 13/11kts, 25p, 60m; 4-450TT
		22	SS54	N2	1917		
		23	SS55	N3	1917		
O	15	24	SS62	O1	1918		521/629(24-32)-491/566(33-38)t, 52.5(24-32)-52.4(33-38)x5.5(24-32)-5.1(33-38)x4.4(24-32)-4.2(33-38)m, 2d/em, 600/550(24-32)-880/740(33-38)hp, 13/11(24-32)-14/10.5(33-38)kts, 25(24-32)-29(33-38)p, 60m; 1x1-76/23, 4-450TT
		25	SS63	O2	1918		
		26	SS64	O3	1918		
		27	SS65	O4	1918		
		28	SS67	O6	1918		
		29	SS68	O7	1918		
		30	SS69	O8	1918		
		31	SS70	O9	1918		
		32	SS71	O10	1918		
		33	SS72	O11	1918		
		34	SS73	O12	1918		

		35	SS74	O13	1918			
		36	SS75	O14	1918			
		37	SS76	O15	1918			
		38	SS77	O16	1918			
	R 27	39	SS78	R1	1918		<p>569/680(39-58)-510/583(59-65)t, 56.8(39-58)-53.3(59-65)x5.5(39-58)-5.1(59-65)x4.4m, 2d/em, 1200/940(39-58)-1000/800(59-65)hp, 13.5/11(39-58)-14/11(59-65)kts, 29p, 60m; 1x1-76/50, 4-533TT(39-58), 4-450TT(59-65)</p>	
		40	SS79	R2	1919			
		41	SS80	R3	1919			
		42	SS81	R4	1919			
		43	SS82	R5	1919			
		44	SS83	R6	1919			
		45	SS84	R7	1919			
		46	SS85	R8	1919			
		47	SS86	R9	1919			
		48	SS87	R10	1919			
		49	SS88	R11	1919			
		50	SS89	R12	1919			
		51	SS90	R13	1919			
		52	SS91	R14	1919			
		53	SS92	R15	1918			
		54	SS93	R16	1918			
		55	SS94	R17	1918			
		56	SS95	R18	1918			
		57	SS96	R19	1918			
		58	SS97	R20	1918			
		59	SS98	R21	1919			
SS			60	SS99	R22			1919
			61	SS100	R23			1919
			62	SS101	R24			1919
			63	SS102	R25			1919
			64	SS103	R26			1919
			65	SS104	R27			1919
		66	SS105	S1	1920			
	67	SS123	S18	1924				
	68	SS124	S19	1921				
	69	SS125	S20	1922				
	70	SS126	S21	1921				
	71	SS127	S22	1924				
	72	SS128	S23	1923				
	73	SS129	S24	1923				
	74	SS130	S25	1923				

S-1	25	75	SS131	S26	1923		854/1062t, 66.9x6.3x4.8m, 2d/em, 1200/1500hp, 14/11kts, 38p, 60m; 1x1-102/50, 4-533TT
		76	SS132	S27	1924		
		77	SS133	S28	1923		
		78	SS134	S29	1924		
		79	SS135	S30	1920		
		80	SS136	S31	1922		
		81	SS137	S32	1922		
		82	SS138	S33	1922		
		83	SS139	S34	1922		
		84	SS140	S35	1922		
		85	SS141	S36	1923		
		86	SS142	S37	1923		
		87	SS143	S38	1923		
		88	SS144	S39	1923		
		89	SS145	S40	1923		
90	SS146	S41	1924				
S-2	2	91	SS153	S42	1924		906/1126t, 68.7x6.3x4.9m, 2d/em, 1200/1200hp, 14.5/11kts, 38p, 60m; 1x1-102/50, 4-533TT
		92	SS154	S43	1924		
S-3	1	93	SS106	S2	1920		800/977t, 63.1x6.0x4.9m, 2d/em, 1800/1200hp, 15/11kts, 38p, 60m; 1x1-102/50, 4-533TT
S-4	14	94	SS107	S3	1919		875/1088(94)-876/1092(95-107)t, 70.4x6.7x4.0m, 2d/em, 1400/1200(94)-2000/1200(95-107)hp, 15/11kts, 38p, 60m; 1x1-102/50, 5-533TT(94-103), 4-533TT(104-107)
		95	SS109	S4	1919		
		96	SS111	S6	1920		
		97	SS112	S7	1920		
		98	SS113	S8	1920		
		99	SS114	S9	1921		
		100	SS115	S10	1922		
		101	SS116	S11	1923		
		102	SS117	S12	1923		
		103	SS118	S13	1923		
		104	SS119	S14	1921		
		105	SS120	S15	1921		
		106	SS121	S16	1920		
		107	SS122	S17	1921		
S-5	4	108	SS159	S48	1922		903/1230t, 73.2x6.6x4.1m, 2d/em, 1800/1500hp, 14.5/11kts, 38p, 60m; 1x1-102/50, 5-533TT
		109	SS160	S49	1922		
		110	SS161	S50	1922		
		111	SS162	S51	1922		
T	3	112	SF1	T1	1920		1107/1482t, 82.0x7.0x4.3m, 2d/em, 4000/1350hp, 20/10.5kts, 38p, 45m; 2x1-76/23, 6-533TT
		113	SF2	T2	1922		

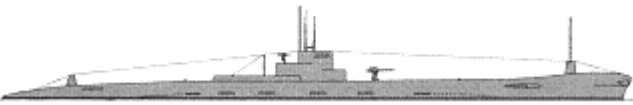
							
		114	SF3	T3	1920		
V1	1	115	SF4	V1	1924		2119/2506t, 102.0x8.4x4.6m, 2d,2dg/2em, 6200/2400hp, 18.7/9kts, 85p, 60m; 1x1-127/51, 6-533TT

## ESCORTS

PC	Eagle	52	1	PE1	Eagle-1	1918		615t, 61.2x10.1x2.6m, 2b,1gt, 2500hp, 18.3kts, 61p; 2x1-102/50, 1x1-76/50, 1DCT
			2	PE2	Eagle-2	1918		
			3	PE3	Eagle-3	1918		
			4	PE4	Eagle-4	1918		
			5	PE5	Eagle-5	1918		
			6	PE6	Eagle-6	1918		
			7	PE7	Eagle-7	1918		
			8	PE8	Eagle-8	1919		
			9	PE9	Eagle-9	1919		
			10	PE10	Eagle-10	1919		
			11	PE11	Eagle-11	1919		
			12	PE12	Eagle-12	1919		
			13	PE13	Eagle-13	1919		
			14	PE14	Eagle-14	1919		
			15	PE15	Eagle-15	1919		
			16	PE18	Eagle-18	1919		
			17	PE19	Eagle-19	1919		
			18	PE23	Eagle-23	1919		
			19	PE24	Eagle-24	1919		
			20	PE26	Eagle-26	1919		
			21	PE27	Eagle-27	1919		
			22	PE28	Eagle-28	1919		
			23	PE29	Eagle-29	1919		
			24	PE32	Eagle-32	1919		
			25	PE33	Eagle-33	1919		
			26	PE34	Eagle-34	1919		
			27	PE35	Eagle-35	1919		
			28	PE36	Eagle-36	1919		
			29	PE37	Eagle-37	1919		
			30	PE38	Eagle-38	1919		
			31	PE39	Eagle-39	1919		
			32	PE40	Eagle-40	1919		

		33	PE41	Eagle-41	1919			
		34	PE42	Eagle-42	1919			
		35	PE43	Eagle-43	1919			
		36	PE44	Eagle-44	1919			
		37	PE45	Eagle-45	1919			
		38	PE46	Eagle-46	1919			
		39	PE47	Eagle-47	1919			
		40	PE48	Eagle-48	1919			
		41	PE49	Eagle-49	1919			
		42	PE50	Eagle-50	1919			
		43	PE51	Eagle-51	1919			
		44	PE52	Eagle-52	1919			
		45	PE53	Eagle-53	1919			
		46	PE54	Eagle-54	1919			
		47	PE55	Eagle-55	1919			
		48	PE56	Eagle-56	1919			
		49	PE57	Eagle-57	1919			
		50	PE58	Eagle-58	1919			
		51	PE59	Eagle-59	1919			
		52	PE60	Eagle-60	1919			
AY	-	9	1	PY1	Mayflower	1896		2690t, 83.2x11.0xm, 2vte, 2400hp, 17kts; 6x1-57/40
			2	PY2	Hawk	1891		545t
			3	PY3	Scorpion	1896		775t
			4	PY5	Sylph	1898		152t
			5	PY6	Nokomis	1914		1265t, 74.1x9.7xm, 16kts; 4x1-76/50
			6	PY7	Aramis	1916		375t
			7	PY8	Despatch	1913		237t
			8	PY9	Niagara	1898		2690t, 86.0x13.1xm, 12kts; 4x1-102/50, 1DCT
			9	PY10	Isabel	1917		710t
			10	PY11	Wenonah	1915		470t; 2x1-76/50

## OTHER FIGHTING SHIPS

		1	PG8	Wilmington	1897	A detailed black and white line drawing of the USS Helena (PG-9), a gunboat, showing its hull, masts, and gun turrets.	1689t, 76.4x12.5x2.7m, 6b,2vte, 1900hp, 15kts, 199p; 25belt, 38deck; 8x1-102/40	
	Wilmington	2	PG9	Helena	1897			
	Callao	1	3	PG39	Pampanga	1889	No picture	243t, 36.9x5.3x2.3m, 1b,1vc, 250hp, 10kts, 30p; 4x1-47/40
	Quiros	1	4	PG42	Villalobos	1896	No picture	370t, 44.2x6.9x2.4m, 2b,1vte, 450hp, 11kts, 57p; 4x1-47/40, 2x1-37/50
	Elcano	1	5	PG38	Elcano	1885	No picture	620t, 50.4x7.9x3.1m, 2b,1vc, 1200hp, 11kts, 103p; 4x1-102/40

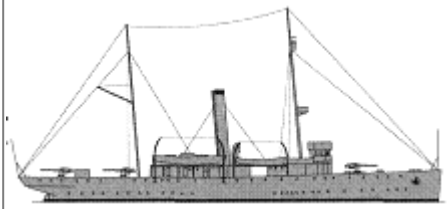
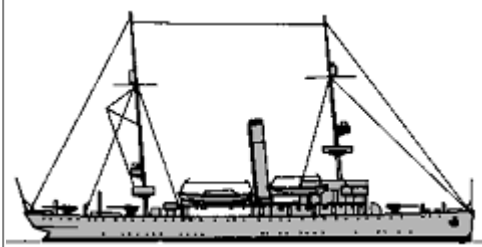
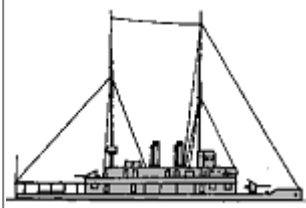
PG	Sacramento	1	6	PG19	Sacramento	1914		1592t, 69.0x12.5x3.5m, 2b,1vte, 950hp, 12.5kts, 163p; 3x1-102/50
	Asheville	2	8	PG22	Tulsa	1923		1760t, 73.5x12.6x3.4m, 3b,1gt, 850hp, 12kts, 159p; 3x1-102/50; 60troops
PR	Palos	2	1	PG16	Palos	1914		204t, 48.8x7.5x0.7m, 2b,2vte, 800hp, 13.3kts, 47p; 2x1-57/40
			2	PG20	Monocacy	1914		

### COASTAL FORCES

PS	SC-110	36	1 - 36	SC2, 26, 57, 63, 64, 102, 103, 116, 143, 154, 159, 186, 192, 200, 210, 214, 224, 229, 231, 238, 252, 271, 285, 306, 320, 326, 328, 330, 341, 353, 412, 419, 432, 433, 437, 440	1917 - 1919		85t, 33.5x4.5x1.7m, 3pe, 660hp, 18kts, 27p; 1x1-76/23, 1DCT
----	--------	----	--------	--	-------------	---	---

### MINE WARFARE

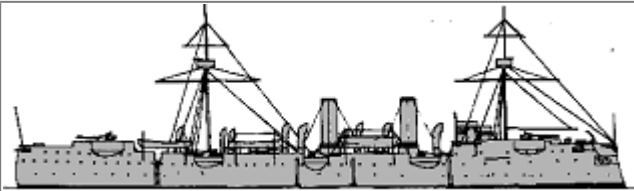
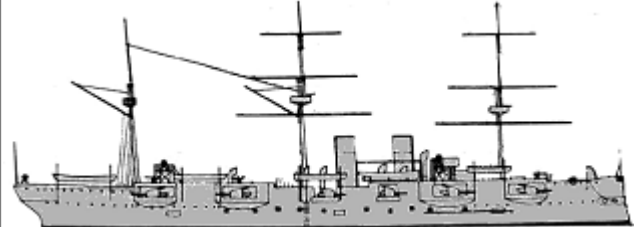
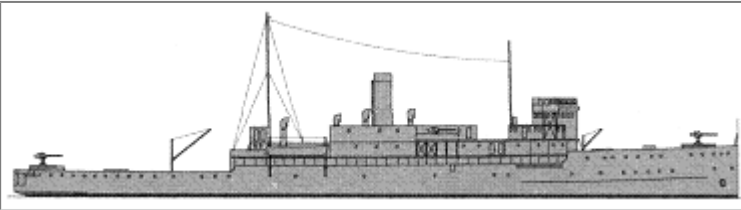
ML	Baltimore	1	1	CM1	Baltimore	1890		5436t, 102.1x14.8x5.9m, 8b,2hte, 10750hp, 19kts, 386p; 64deck, 76CT; 4x1-127/51, 2x1-76/50, 180m
	San Francisco	1	2	CM2	Tahoe	1890		4583t, 98.9x15.0x5.7m, 8b,2hte, 10500hp, 19kts, 384p; 51deck, 76CT; 4x1-127/51, 180m
	Aroostook	2	3	CM3	Aroostook	1917		4200t, 120.4x15.9x4.9m, 8b,2vte, 7000hp, 20kts, 314p; 1x1-127/51, 2x1-76/50, 300m
			4	CM4	Shawmut	1917		
			5	DM1	Stribling	1918		
			6	DM2	Murray	1918		



Stribling

14

7	DM3	Israel	1918
8	DM4	Luce	1918
9	DM5	Maury	1918
10	DM6	Lansdale	1918
11	DM7	Mahan	1918
12	DM8	Hart	1919
13	DM9	Ingraham	1919
14	DM10	Ludlow	1918
15	DM11	Burns	1919
16	DM12	Anthony	1919
17	DM13	Sproston	1919
18	DM14	Rizal	1919

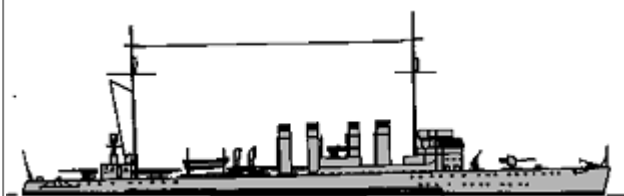

1247t, 95.8x9.4x2.8m, 4b,2t, 27000hp, 35kts, 114p; 4x1-102/50, 1x1-76/23, 2DCR, 80m

MS Bird

44

1	AM1	Lapwing	1918
2	AM2	Owl	1918
3	AM3	Robin	1918
4	AM4	Swallow	1918
5	AM5	Tanager	1918
6	AM7	Oriole	1918
7	AM8	Curlew	1919
8	AM9	Finch	1918
9	AM10	Heron	1918
10	AM13	Turkey	1918
11	AM14	Woodcock	1919
12	AM15	Quail	1919
13	AM16	Partridge	1919
14	AM17	Eider	1919
15	AM18	Thrush	1919
16	AM19	Avocet	1919
17	AM20	Bobolink	1919
18	AM21	Lark	1919
19	AM22	Widgeon	1918
20	AM23	Teal	1918
21	AM24	Brant	1918
22	AM25	Kingfisher	1918
23	AM26	Rail	1918
24	AM27	Pelican	1918
25	AM28	Falcon	1918
26	AM30	Seagull	1919
27	AM31	Tern	1919
28	AM33	Penguin	1919
29	AM34	Swan	1919





1400t, 57.6x10.8x3.8m, 2b,1vte, 1400hp, 13.5kts, 85p; 2x1-76/50, MS, m

30	AM35	Whippoorwill	1919
31	AM36	Bittern	1919
32	AM37	Sanderling	1918
33	AM39	Chewink	1919
34	AM40	Cormorant	1919
35	AM41	Gannet	1919
36	AM43	Grebe	1919
37	AM44	Mallard	1919
38	AM45	Ortolan	1919
39	AM46	Peacock	1919
40	AM47	Pigeon	1919
41	AM51	Sandpiper	1919
42	AM52	Vireo	1919
43	AM53	Warbler	1919
44	AM54	Willet	1920

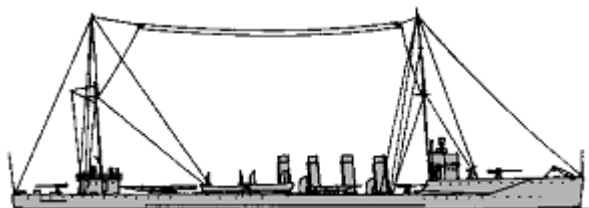
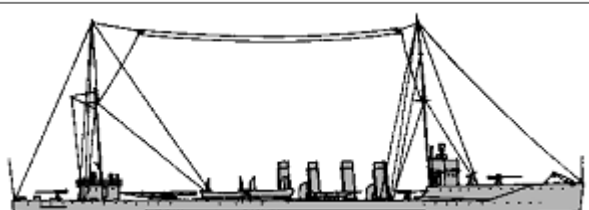
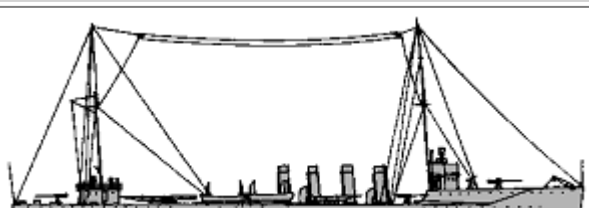
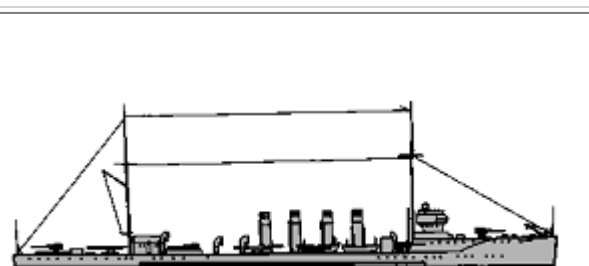
COAST GUARD CUTTERS

DD	Cassin	3	1	CG1	Cassin	1913		1235t, 93.1x9.2x3.0m, 4b,2t, 16000hp, 29kts, 98p; 3x1-102/50(1,2), 4x1-102/50(3), 4x2-450TT, 1DCT, 2DCR
			2	CG3	Cummings	1913		
			3	CG4	Downes	1915		
	Tucker	2	4	CG2	Conyngham	1916		1205t, 96.1x9.3x2.9m, 4b,2t, 18000hp, 29.5kts, 99p; 4x1-102/50, 4x2-533TT, 1DCT, 2DCR
			5	CG7	Porter	1916		
	O'Brien	2	6	CG5	Ericsson	1915		1171t, 93.1x9.5x2.9m, 4b,2t, 17000hp, 29kts, 101p; 4x1-102/50, 4x2-533TT, 1DCT, 2DCR
			7	CG6	McDougal	1914		
	Monaghan	8	8	CG8	Ammen	1911		883t, 89.5x8.2x2.5m, 4b,3t(6-8,10-13)-3gt(9), 12000(6-8,10-13)-13000(9)hp, 29.5kts, 89p; 5x1-76/50(6,8-13), 4x1-76/50(7), 3x2-450TT, 1DCT, 2DCR
			9	CG9	Beale	1912		
			10	CG11	Fanning	1912		
			11	CG12	Henley	1912		
			12	CG13	Jouett	1912		
			13	CG15	Monaghan	1911		
	14	CG16	Patterson	1911				

			15	CG20	Trippe	1911		
	Paulding	5	16	CG10	Burrows	1911		887t, 89.6x8.0x2.4m, 4b,3t, 12000hp, 29.5kts, 86p; 5x1-76/50, 3x2-450TT, 1DCT, 2DCR
			17	CG14	McCall	1911		
			18	CG17	Paulding	1910		
			19	CG18	Roe	1910		
			20	CG19	Terry	1910		
PS	SC-110	6	1 - 6	-	Hansen, Vaughan, Smith, Tingard, Cygan, Cook	1917 - 1919		85t, 33.5x4.5x1.7m, 3pe, 660hp, 18kts, 27p; 1x1-76/23, 1DCT
CGC	Manhattan	1	1	-	Arundel	1873	No picture	147t, 31.1x6.2x2.6m, 1vc, 16p; 1x1-57/40
	Lot M. Morrill	1	2	-	Lot M. Morrill	1889	No picture	288t, 44.3x7.3x2.9m, 1b,1vc, 13kts, 38p; 1x1-76/50, 2x1-57/40
	Galveston	1	3	-	Apache	1891	No picture	708t, 57.9x8.8x2.8m, 2b,1vte, 12kts, 41p; 3x1-76/50
	William Windom	1	4	-	Comanche	1896	No picture	670t, 52.0x8.2x2.9m, 2b,2vte, 800hp, 15kts, 49p; 1x1-76/50, 2x1-57/40
	Gresham	3	5	CG1	Gresham	1897	No picture	1190t, 62.6x9.8x3.4m, 4b(5)-2b(6,7),1vte, 2500hp, 17kts, 73p; 4x1-102/50(6), 4x1-76/50(5,7)
			6	CG2	Manning	1898		
			7	CG4	Algonquin	1898		
	Seminole	1	8	CG6	Seminole	1900	No picture	860t, 57.3x8.8x3.4m, 2b,1vte, 14.7kts, 67p; 4x1-76/50
	Tuscarora	1	9	CG7	Tuscarora	1902	No picture	739t, 54.3x9.1x3.4m, 1b,1vte, 14.2kts, 65p; 1x1-76/50, 2x1-57/40
	Pamlico	1	10	CG15	Pamlico	1907	No picture	455t, 48.2x9.1x1.7m, 1b,2vte, 600hp, 9.8kts, 33p; 2x1-57/40
	Androscoggin	1	11	CG14	Androscoggin	1908	No picture	1605t, 64.0x10.7x5.3m, 2b,1vte, 1800hp, 13kts, 74p; 3x1-76/50, 1x1-57/40
	Tahoma	1	12	CG21	Yamacraw	1909	No picture	1082t, 58.2x9.8x4.3m, 1vte, 14.1kts, 69p; 2x1-76/50
	Snohomish	2	13	CG16	Snohomish	1908	No picture	879t, 46.3x8.8x4.2m, 2b,1vte, 1200hp, 12kts, 53p; 1x1-76/50, 2x1-57/40
			14	-	Acushnet	1908		
	Seneca	1	15	CG17	Seneca	1908	No picture	1445t, 62.2x10.4x5.2m, 2b,1vte, 1500hp, 12.5kts, 74p; 4x1-102/50
	Miami	1	16	CG53	Unalga	1912	No picture	1181t, 57.9x9.9x4.3m, 1vte, 1300hp, 13kts; 2x1-102/50, 2x1-76/50, 2DCR
	Ossipee	2	17	CG26	Ossipee	1915	No picture	997t, 50.5x9.8x3.6m, 2b,1vte, 1000hp, 12.7kts, 72p; 2x1-57/40, 1DCT
18			CG27	Tallapoosa	1915			
Haida	4	19	CG45	Haida	1921	No picture	1955t, 73.2x11.9x5.0m, 2b,1tg,1em, 2600hp, 15kts, 122p; 2x1-127/51, 1x1-76/50(20), 2x1-57/40, 1x1-37/50(19,21,22)	
		20	CG46	Modoc	1922			
		21	CG47	Mojave	1921			
		22	CG48	Tampa	1921			
CGB	75ft CGB	~70	1 - 70	CG100 - 169	-	1924	No picture	37t, 22.9x4.2x1.2m, 1pe, 400hp, 13.5kts; 1x1-37/50

#### NAVAL AVIATION (approximately, maximal number of delivered planes signed)

Deck planes	F: 24 VE-7G, 39 TS-1; TB: 35 SC-1; R: 29 VE-7, 29 VE-7F, 36 MO-1
Seaplanes	F: 70 VE-7SF; TB: 75 DT-2 (partly wheeled); R: 141 UO-1 (partly wheeled, delivery till 1927)

© Ivan Gogin, 2011

[home](#)

[World navies yesterday](#)

[1925](#)

## Uruguay 01 January 1925

### CRUISERS

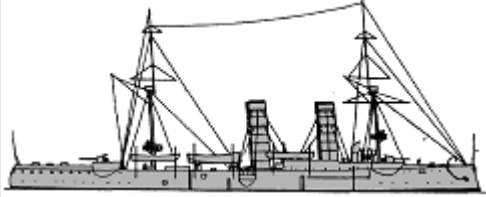
CL	Montevideo	1	1	Montevideo	1887		2050t, 76.2x11.3x4.4m, 4b,2vte, 5012hp, 17.7kts, 250p; compound: 51deck, 114shields, 51CT; 6x1-152/40, 9x1-57/40, 4-450TT
----	------------	---	---	------------	------	--	---

### TORPEDO SHIPS

PGT	Uruguay	1	1	Uruguay	1910		1400t, 85.0ppx9.4x3.6m, 4b,2vte, 5700hp, 23kts, 125p; steel: 17deck; 2x1-120/45, 4x1-76/40, 6x1-37/43, 2x1-450TT
-----	---------	---	---	---------	------	--	--

© Ivan Gogin, 2011-15

[home](#)[World navies yesterday](#)[1925](#)

# Venezuela 01 January 1925

## OTHER FIGHTING SHIPS

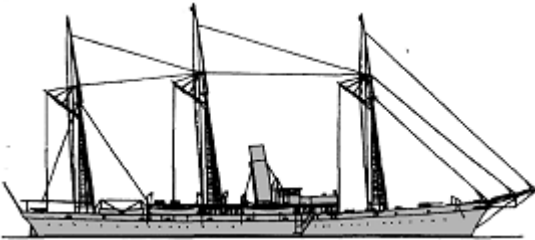
	Miranda	1	1	Miranda	1895	No picture	200t, 41.5x5.8x2.5m, 1b,1vte, 315hp, 10kts, 55p; 4x1-57/43
PG	Mariscal Sucre	1	2	Mariscal Sucre	1887		1030t, 58.6x8.9x3.8m, 2b,2hte, 2627hp, 15.9kts, 92p; 2x1-102/40, 2x1-57/40, 6x1-47/40, 2x1-37/40; 300troops
APG -		2	1	General Salóm	1884		750t; 1x1-76/40
			2	Jose Felix Ribas	1894		300t

Google  
Custom Search



© Ivan Gogin, 2011-15

[home](#)[World navies yesterday](#)[1925](#)

# Yugoslavia 01 January 1925

*IN SERVICE: 9 torpedo boats, 4 river monitors, 7 minesweepers*

## TORPEDO SHIPS

TB	T9	1	1	T11	1909		203t, 56.9x5.4x1.4m, 2b,1vte, 3000hp, 26.2kts, 38p; 4x1-47/33, 3x1-450TT
	T1	4	2	T1	1914		320t, 58.2x5.7x1.5m, 2b,2t, 5000hp, 28kts, 52p; 2x1-66/50, 2x2-450TT
			3	T2	1914		
			4	T3	1914		
			5	T4	1914		
	T5	4	6	T5	1915		330t, 58.8x5.8x1.5m, 2b,2t, 5000hp, 28kts, 52p; 2x1-66/50, 2x2-450TT
			7	T6	1916		
			8	T7	1916		
			9	T8	1916		

## OTHER FIGHTING SHIPS

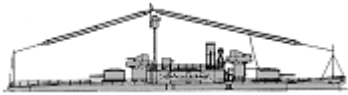
RMON	Morava	1	1	Morava	1892		448t, 54.0x9.0x1.2m, 2b,2vte, 1200hp, 10kts, 84p; 50belt, 19deck, 75CT; 2x1-120/35, 1x1-66/42, 1x1-15
	Sava	1	2	Sava	1904		470t, 57.7x9.5x1.2m, 2b,2vte, 1400hp, 13kts, 86p; 40belt, 25deck, 75CT; 2x1-120/35, 1x1-120/10, 1x1-66/50
	Drava	1	3	Drava	1914		540t, 57.9x10.3x1.3m, 2b,2vte, 1500hp, 13kts, 95p; 50belt, 19deck, 75CT; 1x2-120/40, 3x1-120/10, 2x1-66/50
	Vardar	1	4	Vardar	1915		580t, 62.0x10.3x1.3m, 2b,2vte, 1750hp, 13.5kts, 91p; 40belt, 25deck, 50CT; 1x2-120/40, 2x1-120/10, 2x1-66/50, 2x1-47/44

## MINE WARFARE SHIPS

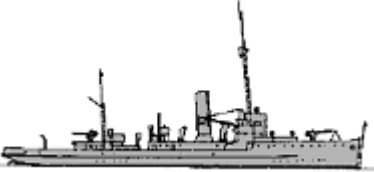
MS	D1	1	1	D2	1888		88t, 39.9x4.8x1.9m, 1b,1vte, 1000hp, 19kts, 16p; 2x1-37/23, MS
	Orao	6	2	Orao	1918		590t, 59.6x7.3x2.2m, 2b,2vte, 1840-1850hp, 16kts, 51p; 2x1-90/45, 24m, MS
			3	Galeb	1918		
			4	Gavran	1919		
			5	Jastreb	1919		
			6	Kobac	1918		
			7	Sokol	1919		

© Ivan Gogin, 2011