

[home](#)

# THE NAVAL BALANCE 1920

## Navies of the world

01/01/1920

1. United Kingdom - 3238 tt; 2. USA - 1559 tt; 3. France - 749 tt; 4. Japan - 747 tt; 5. Italy - 438 tt; 6. Russia - 322 tt; 7. Germany - 219 tt; 8. Argentina - 124 tt

*tt - thousand ton*

[Argentina](#)

[Australia](#)

[Belgium](#)

[Brazil](#)

[Bulgaria](#)

[Canada](#)

[Chile](#)

[China](#)

[Colombia](#)

[Cuba](#)

[Denmark](#)

[Ecuador](#)



**КРАСИВЫЕ  
НОМЕРА  
ПО ЧЕСТНОЙ  
ЦЕНЕ**

Бесплатная доставка  
при покупке  
в интернет-магазине  
Tele2

**ПОДРОБНЕЕ**

**TELE2**

[Egypt](#)

[Estonia](#)

[Finland](#)

[France](#)

[Germany](#)

[Greece](#)

[Honduras](#)

[Hungary](#)

[India](#)

[Italy](#)

[Japan](#)

[Latvia](#)

[Mexico](#)

[Netherlands](#)

[New Zealand](#)

[Nicaragua](#)

[Norway](#)

[Paraguay](#)

[Persia](#)

[Peru](#)

[Portugal](#)

[Romania](#)

[Russia](#)

[Siam](#)

[Spain](#)

[Sweden](#)

[Turkey](#)

[United Kingdom](#)

[United States of America](#)

[Uruguay](#)

[Venezuela](#)

[Yugoslavia](#)

**1576480**



[Website Hit Counter](#)

© Ivan Gogin, 2015

[home](#)[World navies yesterday](#)[1920](#)

# Argentina 01 January 1920

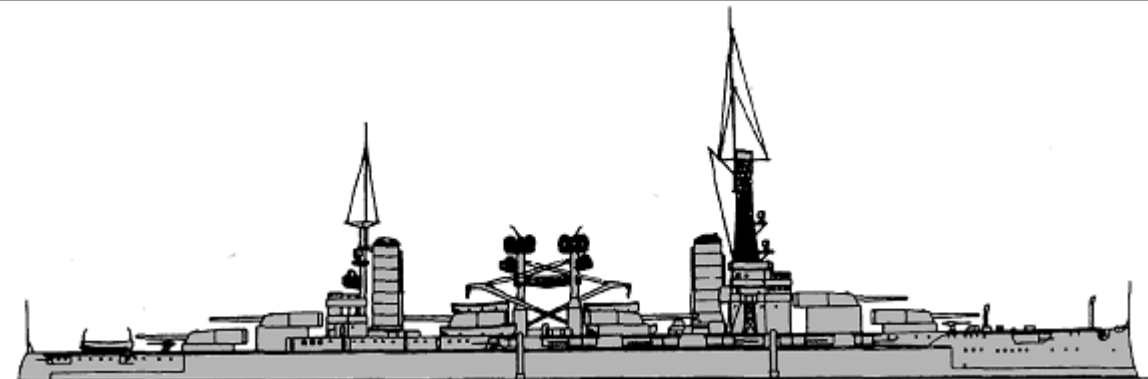
## BATTLESHIPS

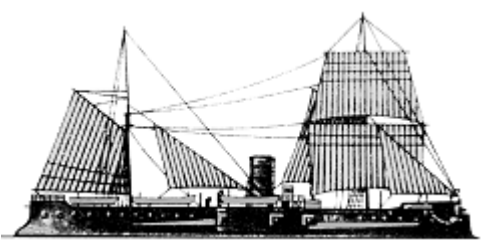
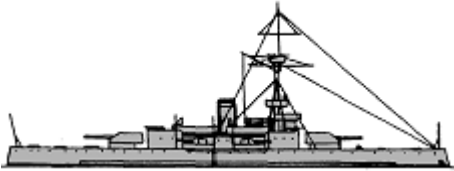

BB	Rivadavia	1	Rivadavia	1914		<p>30600t, 181.3x30.0x8.5m, 18b,3gst, 39500hp, 22.5kts, 1130p; 280belt, 114deck, 305turrets, 305CT; 6x2-305/50, 12x1-152/50, 16x1-102/50, 2-533TT</p>
		2	Moreno	1915		
El Plata		1	El Plata	1875		<p>1500t, 56.7x13.4x3.2m, 4b,2vc, 750hp, 9.5kts, 126p; iron- 152belt, 30deck, 229turret; 1x2-203/30, 2x1-120/40, 2x1-57/40, 4x1-25/42</p>
		2	Los Andes	1875		
BC	Almirante Brown	1	Almirante Brown	1882		<p>4200t, 73.2ppx15.2x6.3m, 8b,2vc, 5400hp, 14kts, 520p; compound- 229belt, 203battery, 203CT; 10x1-150/50, 6x1-120/50, 2x1-47/40, 2-450TT</p>
		3				
Libertad		4	Libertad	1892		<p>2595t, 70.1ppx13.1x4.0m, 4b,2vte, 2780hp, 14.2kts, 230p; steel- 203belt, 37deck, 203barbettes, 102CT; 2x1-238/32, 4x1-120/41, 4x1-47/42, 2-450TT</p>
		5	Independencia	1892		

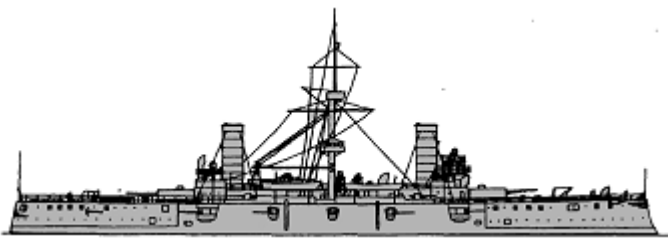
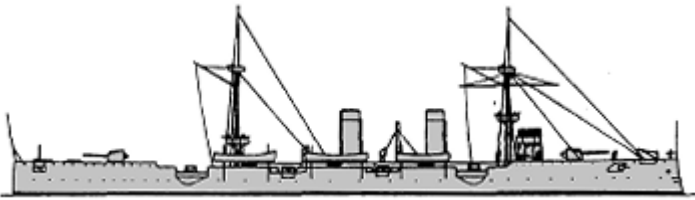
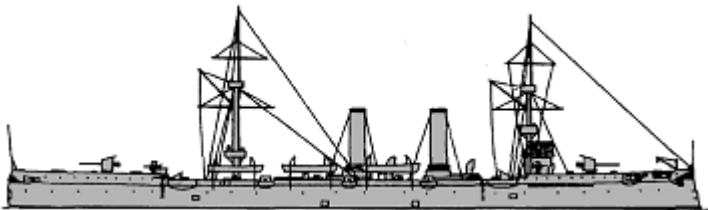
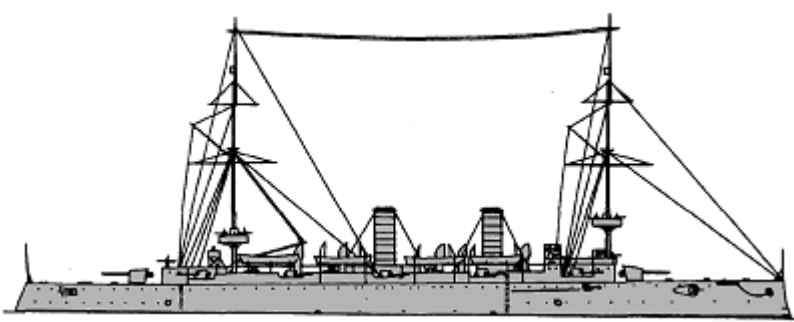

## CRUISERS

CA	Garibaldi	4	1	Garibaldi	1896	<p>6775t, 111.7x18.2x7.1m, 8b,2vte(1-3)-16b,2vte(4), 13000hp, 20kts, 500-540p; Harvey(1-3)- 150belt, 150turrets, 37deck, 150CT; 2x1-254/40(1,3,4), 2x2-203/45(2), 10x1-152/40(1,2), 14x1-152/40(3,4), 6x1-120/41(1,2), 2x1-76/40(3,4), 10x1-57/40, 10x1-37/20(1,2), 12x1-37/20(3,4)</p>
			2	San Martin	1898	
			3	General Belgrano	1898	

			4	Pueyrredon	1898					
CL	Veinticinco de Mayo	1	1	Veinticinco de Mayo	1891		3500t, 107.9x13.4x4.9m, 4b,2vte, 14050hp, 22.4kts, 320p; steel- 114slopes, 89deck, 51shields, 102CT; 1x1-209/32, 8x1-120/37, 12x1-47/37, (1+2x1)-450TT			
	Nueve de Julio	1	2	Nueve de Julio	1893		3600t, 113.5x13.4x5.0m, 8b,2vte, 14500hp, 22.2kts, 327p; steel- 114slopes, 89deck, 51shields, 102CT; 4x1-152/40, 8x1-120/41, 12x1-47/40, 5-450TT			
	Buenos Aires	1	3	Buenos Aires	1896		4788t, 129.2x12.9x5.6m, 8b,2vte, 17000hp, 24kts, 350p; steel- 127slopes, 38deck, 114shields, 152CT; 2x1-203/45, 4x1-152/45, 6x1-120/44, 16x1-47/40, 5-450TT			

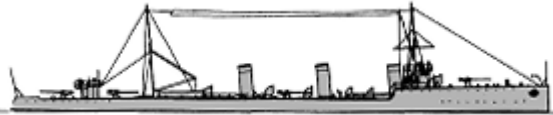
TORPEDO SHIPS

PGT	Patria	1	1	Patria	1894		1029t, 76.7x9.6x3.0m, 4b,2vte, 5000hp, 20.5kts, 100p; 2x1-120/41, 4x1-63/42, 2x1-47/42, 5-450TT			
DD	Corrientes	3	1	Corrientes	1898		280t, 57.9x5.9x2.2m, 6b,2vte, 4200hp, 27kts, 54p; 1x1-76/46, 3x1-57/42, (1+2x1)-450TT			
			2	Entre Rios	1896					
			3	Misiones	1897					
	Catamarca	2	4	Catamarca	1912		1357t, 88.1x8.3x2.6m, 5b,2st, 25765hp, 27kts, 150p; 4x1-102/50, 4x1-533TT			
			5	Jujuy	1912					
	La Plata	2	6	Córdoba	1912		1368t, 90.0x9.0x2.8m, 5b,2st, 28000hp, 35kts, 150p; 4x1-102/50, 4x1-533TT			
			7	La Plata	1912					

TB	Nr.1	8	1-8	Nr.1-8	1890		16t, 18.3x2.8x1.1m, 1b,1vte, 230-250hp, 17-18kts, 10p; 1x1-47/42, 1x1-356TT
	Bouchard	4	9-12	Bouchard, Bathurst, Jorge, Thorne	1890-1892		90t, 39.6ppx4.3x1.8m, 2b,2vte(9,11,12)-2b,1vqe(10), 1110(9,11,12)-1230(10)hp, 23.5(9,11,12)-24.4(10)kts, 15p; 2x1-47/42, 1x4-25/42, (1+1x2)-450TT
	Comodoro Py	2	13	Comodoro Py	1892	No picture	110t, 45.7x4.4x1.1m, 2b,1vte, 1800hp, 25kts, 27p; 2x1-47/42, 1x4-25/42, (1+1x2+1x1)-450TT
14			Comodoro Murature	1892			

## OTHER FIGHTING SHIPS

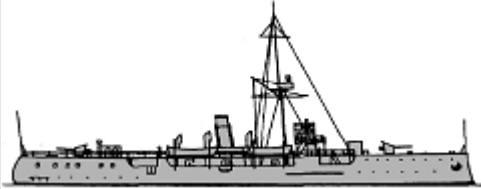
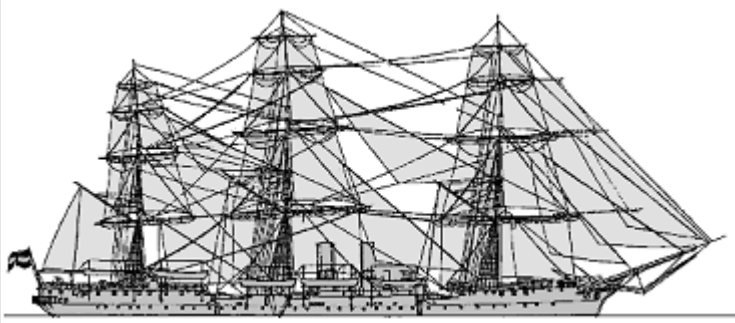
PGR	Rosario	2	1	Rosario	1909		1055t, 76.4x9.8x2.1m, 2b,2vte, 1300hp, 14.5kts, 145p; 76belt, 25deck, 76CT; 2x1-152/13, 6x1-76/40
			2	Paraná	1909		
CT	Presidente Sarmiento	1	1	Presidente Sarmiento	1898		2733t, 85.5ppx13.3x5.9m, 4b,2vc, 1800hp, 13kts, 305+40p, 4x1-120/43, 6x1-57/42, 2x1-37/27, 3-356TT

© Ivan Gogin, 2015

[home](#)[World navies yesterday](#)[1920](#)

# Australia 01 January 1920

## CAPITAL SHIPS

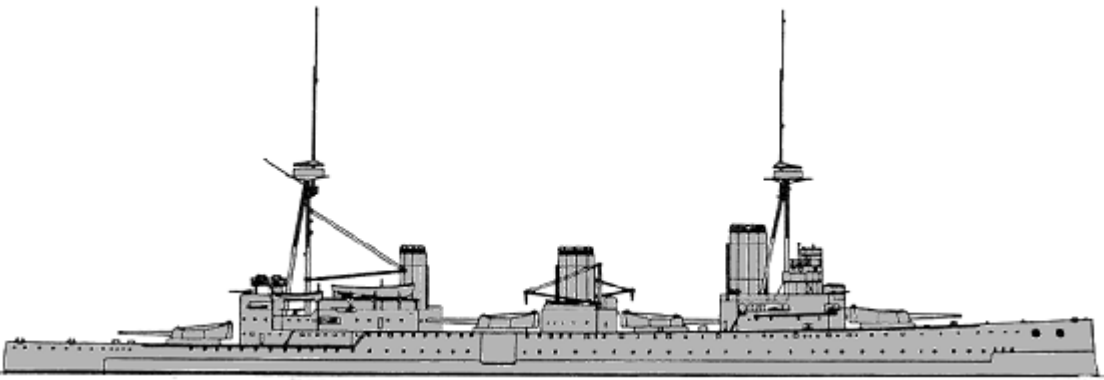

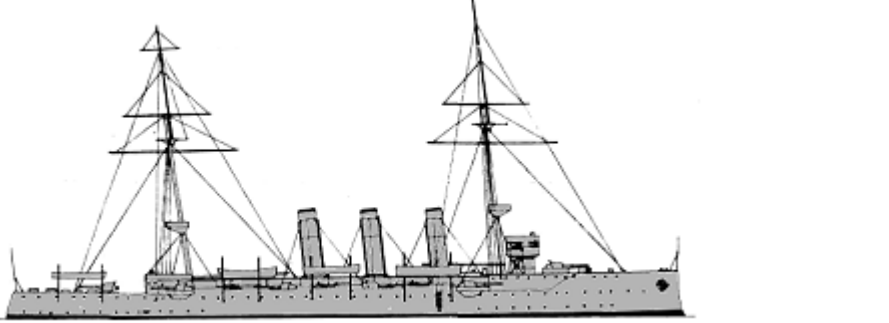
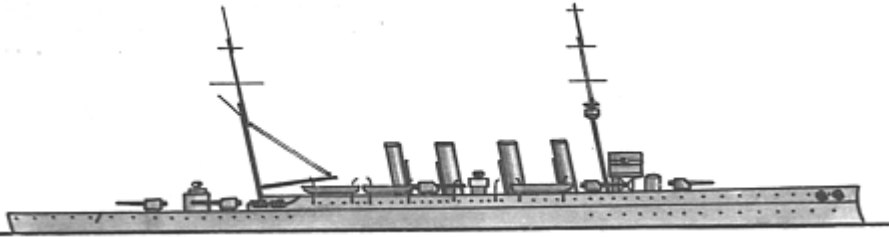

CB	Indefatigable	1	1	Australia	1913		22110t, 179.8x24.4x8.1m, 32b,4st, 44000hp, 25kts, 800p; 152belt, 89deck, 178turrets, 254CT; 4x2-305/45, 15x1-102/50, 1x1-76/45, 4x1-47/40, 2-450TT, 2aircraft(1 Pup, 1 1 <sup>1</sup> / <sub>2</sub> -strutter)
----	---------------	---	---	-----------	------	--	---

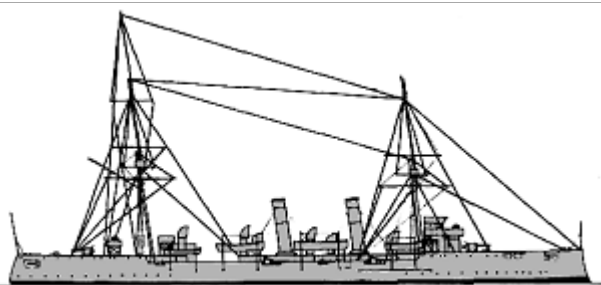
## CRUISERS

CL	Challenger	1	1	Encounter	1905		5880t, 113.4x16.5x6.3m, 18b,2vte, 12500hp, 21kts, 450p; 76deck, 76shields, 152CT; 11x1-152/45, 9x1-76/40, 6x1-47/40, 2-450TT
	Chatham	3	2	Melbourne	1913		6000t, 139.6x14.9x4.9m, 12b,4st, 25000hp, 25.5kts, 475p; 51belt, 38deck, 102shields, 102CT(4); 8x1-152/50, 1x1-76/45, 4x1-47/40, 2-533TT
3			Sydney	1913			
			4	Brisbane	1916		
CLL	Pelorus	2	1	Pioneer	1900		2135-2200t, 95.6x11.1x4.9m, 16b,2vte, 7000hp, 20kts, 224p; steel: 51deck, 76shields, 76CT;

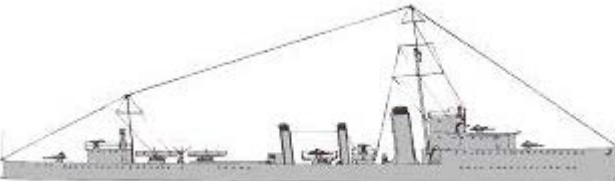
							8x1-102/40, 8x1-47/40, 3x1-7.7, 2-450TT
			2	Psyche	1900		

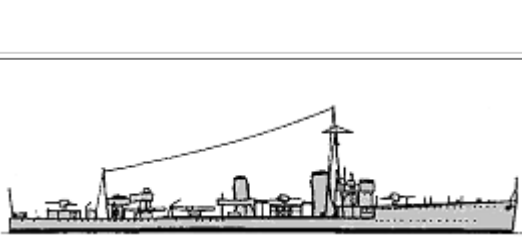
### TORPEDO SHIPS

DL	Parker	1	1	Anzac	1917		1912t, 99.0x9.7x3.7m, 4b,3st, 36000hp, 34kts, 116p; 4x1-102/40, 2x1-40/39, 2x2-533TT
DD	I Australian	6	1	Parramatta	1910		990t, 75.0x7.8x2.7m, 3b,3st, 13500hp, 27kts, 70p; 1x1-102/40, 3x1-76/40, 3x1-450TT
			2	Yarra	1910		
			3	Warrego	1912		
			4	Huon	1915		
			5	Torrens	1916		
			6	Swan	1916		
	S Admiralty	5	7	Success	1919		1225t, 84.1x8.2x2.8m, 3b,2gt, 27000hp, 36kts, 90p; 3x1-102/40, 1x1-40/39, 2x2-533TT, 2dct, 1dcr
			8	Swordsman	1919		
			9	Stalwart	1918		
			10	Tasmania	1919		
			11	Tattoo	1919		
TB	Countess of Hopetown	1	1	Countess of Hopetown	1890		82t, 36.6x4.1xm, 1b,1vte, 1150hp, 23kts, 19p; 3x1-47/40, (2+1x1)-356TT

### SUBMARINES

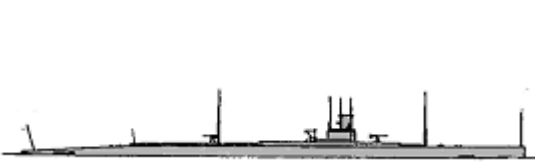
SS	J	6	1	J1	1916		1204/1820(1-5)-1212/1820(6)t, 84.0(1-5)-83.7(6)x7.0x4.3m, 3d/em, 3600/1350hp, 19.5/9.5kts, 44p, 50m; 1x1-102/41(5,6), 1x1-102/40(1,2,4), 1x1-76/30(3), 1x1-76/28(3), 1x1-40/37(1,2,4-6), 6-450TT, 2dcr(1)
			2	J2	1916		
			3	J3	1916		
			4	J4	1916		
			5	J5	1916		
			6	J7	1917		

### ESCORTS

--	--	--	--	--	--	--	--

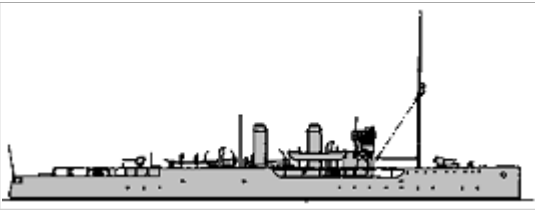
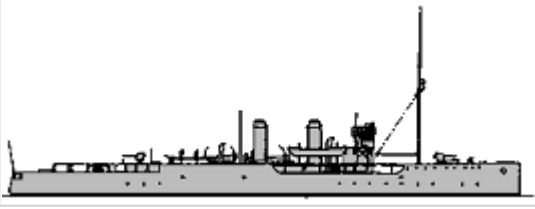

SL	Acacia	1	1	Mallow	1915		1275t, 80.0x10.1x3.4m, 2b,1vte, 1800hp, 16.5kts, 90p; 2x1-76/40, 2x1-47/40, 2dct, 1dcr, sweeps
	Arabis	2	2	Geranium	1916		1350t, 81.7x10.2x3.4m, 2b,1vte, 2000hp, 16kts, 104p; 2x1-120/40 or 2x1-102/44 or 2x1-102/45 or 2x1-102/40, 2x1-47/40, 2dct, 1dcr, sweeps
3		3	Marguerite	1916			
APV	-	2	1	Mourilyan	1908		1349brt, 67.3x11.0m, 2vte, 11.5kts; 1x1-120/40, 2x1-47/40
			2	Coogie	1887		762brt; 1x1-120/40
AY	-	1	1	Franklin	1905		288brt





© Ivan Gogin, 2014

[home](#)[World navies yesterday](#)[1920](#)

## Belgium 01 January 1920

### TORPEDO SHIPS

TB	A1 PC	9	1	A1 PC	1915		137t, 41.6x4.6x1.2m, 1b,1vte, 1093hp, 19kts, 28p; 1x1-50/37, 2x1-450TT, 4mines, sweeps
			2	A2 PC	1915		
			3	A3 PC	1915		
			4	A4 PC	1915		
			5	A5 PC	1915		
			6	A6 PC	1915		
			7	A7 PC	1915		
			8	A8 PC	1915		
			9	A9 PC	1915		
	A22 PC	6	10	A22 PC	1916		250t, 50.0x5.3x2.1m, 1b,1gst, 3250hp, 25kts, 29p; 2x1-88/27, 1x1-450TT, sweeps
			11	A23 PC	1917		
			12	A24 PC	1917		
			13	A25 PC	1917		
			14	A26 PC	1917		
			15	A29 PC	1916		

### ESCORTS

FPV	Ville d'Anvers	1	1	Ville d'Anvers	1886	No picture	684t, 65.2x9.1x3.6m, 45p
-----	----------------	---	---	----------------	------	------------	--------------------------

### MINE WARFARE SHIPS

MSB	V1	12	1-12	V1 Roi Albert, V2 Reine Elisabeth, V3 Prince Leopold, V4, V5 Chevalier Casaert, V6 Roi Leopold I, V7 Roi Leopold II, V8 Princesse Marie-José, V9 Dinant, V10-12	1917-1918		21t, 17.5x4.0x1.1m, 2pe, 120-130hp, 10-11kts, 7p; (0-1)x5-37/17, sweeps
-----	----	----	------	---	-----------	---	---

© Ivan Gogin, 2015

[home](#)

[World navies yesterday](#)



[1920](#)

# Brazil 01 January 1920

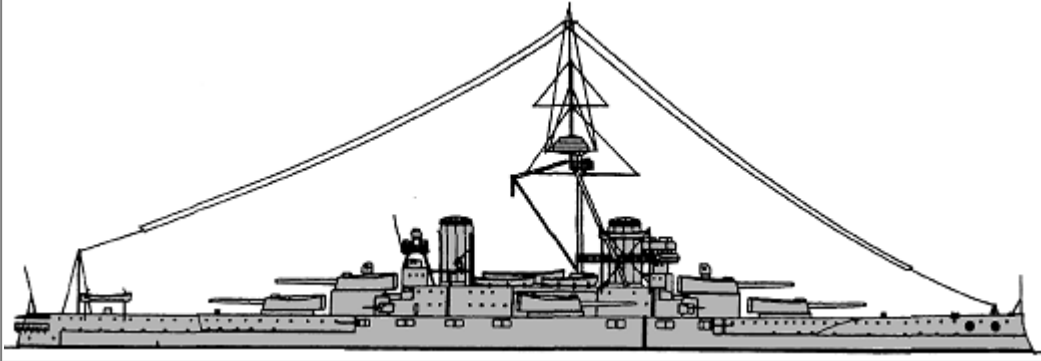
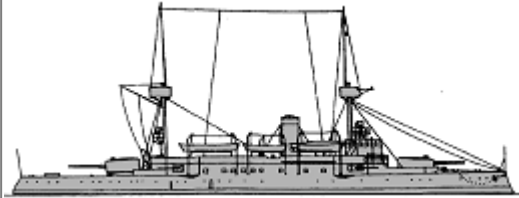
## BATTLESHIPS

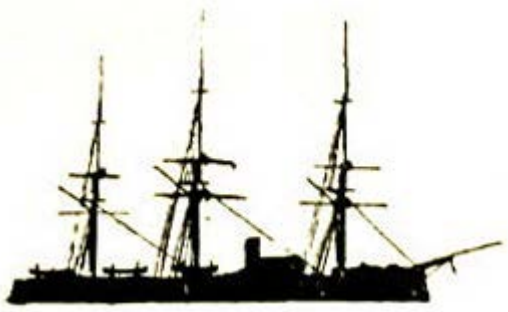

BB	Minas Gerais	1	Minas Gerais	1910		21200t, 165.5x25.3x7.6m, 18b,2vte, 23500hp, 21kts, 900p; 229belt, 51deck, 229turrets, 305CT; 6x2-305/45, 22x1-120/50, 18x1-47/50
		2	São Paulo	1910		
BC	Marshal Deodoro	1	Marshal Deodoro	1900		3162t, 81.5x14.4x4.2m, 8b,2vte, 3400hp, 15kts, 200p; Harvey- 350belt, 45deck, 220turrets, 125CT; 2x1-234/45, 4x1-120/50, 6x1-57/40, 2-450TT
		2	Marshal Floriano	1901		

## CRUISERS

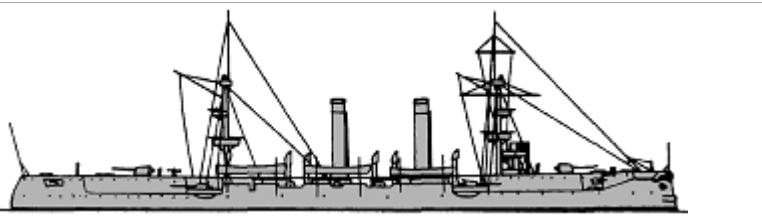
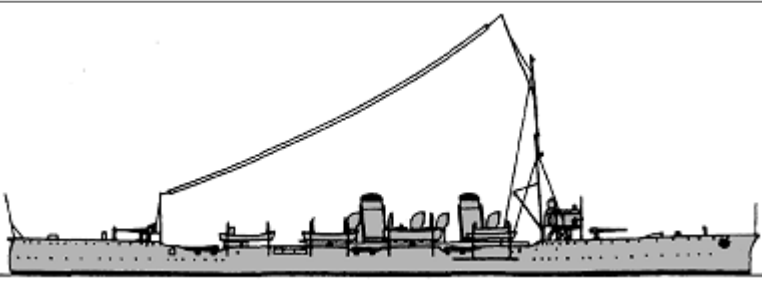
CL	Benjamin Constant	1	Benjamin Constant	1894		2820t, 74.0x13.6x5.6m, 2vte, 4000hp, 15kts, 216+184p; 51deck, 95CT; 4x1-152/40, 8x1-120/40, 2x1-76/40, 2x1-37/20, 2x5-37/17, 4-450TT
	República	1	República	1894		
						1300t, 64.0ppx10.7x3.9m, 2hte, 3800hp, 17.4kts, 160p; steel- 51slopes, 25deck; 6x1-120/40, 4x1-57/40, (1+2x1)-356TT

	Almirante Barroso	1	3	Almirante Barroso	1897		3437t, 108.0x13.3x5.2m, 4b,2vte, 7500hp, 20.2kts, 366p; 88slopes, 31deck, 102CT; 6x1-152/50, 4x1-120/50, 10x1-57/40, 4x1-37/20, 3-450TT
	Bahia	2	5	Rio Grande do Sul	1910		3185t, 122.4x11.9x4.4m, 10b,3st, 18000hp, 26.5kts, 350p; 31slopes, 19deck, 76CT; 10x1-120/50, 6x1-47/40, 2x1-450TT

### TORPEDO SHIPS

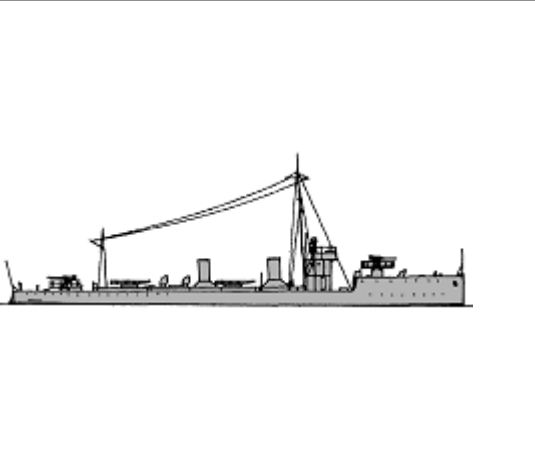
PGT	Tiradentes	1	1	Tiradentes	1893		795t, 50.3ppx9.1x3.3m, 2vte, 1646hp, 14.5kts, 110p; steel- 25CT; 4x1-120/40, 3x1-57/40, 2x1-356TT
	Tamoio	1	4	Tamoio	1900		1063t, 82.0x8.8x3.0m, 2vte, 6500hp, 23kts, 110p; steel- 13deck, 114shields, 25CT; 2x1-120/37, 6x1-57/37, 2x1-37/37, (1+2x1)-356TT
DD	Pará	10	1	Amazonas	1909		560t, 73.2ppx7.2x2.4m, 2b,2vte, 8000hp, 27kts, 130p; 2x1-102/40, 4x1-47/40, 2x1-450TT
			2	Pará	1909		
			3	Piauí	1909		
			4	Rio Grande do Norte	1909		
			5	Paraíba	1909		
			6	Mato Grosso	1909		
			7	Alagoas	1910		
			8	Sergipe	1910		
			9	Paraná	1910		
			10	Santa Catharina	1910		
TB	Goiás	1	1	Goiás	1907	No picture	150t, 46.3ppx4.7x1.3m, 2vte, 1st(3), 950hp, 26kts, 30p; 2x1-47/40, 2x1-450TT

### SUBMARINES

SS	F1	3	1	F1	1913		250/305t, 46.0ppx4.4x3.7m, 2d/em, 700/500hp, 13.5/8kts, 20p, 40m; 2-450TT
			2	F2	1914		
			3	F3	1914		

## OTHER FIGHTING SHIPS

RMON	Pernambuco	1	1	Pernambuco	1910		470t, 44.5x7.3x1.6m, 2b,2vte, 800hp, 11kts, 60p; 168belt, 102deck, 152turret, 89CT; 1x2-120/45, 2x1-57/42, 2x1-37/27
PGR	Yutohy	1	1	Teffé	1892	No picture	33t, 27.4ppx4.6x1.5m, 11kts; 1x1-47/40
	Acre	2	2	Acre	1906	No picture	200t, 36.6x6.1x0.6m, 1b,1vte, 300hp, 11kts, 30p; 1x1-87/13, 1x1-57/42
			3	Missões	1906		
APGR	-	3	1	Oyapock	1908		295t
			2	Tenente Mário Alves	1913		280t
			3	Amapá	1912		320t

## MINE WARFARE SHIPS



AML	-	3	1	Carlos Cromez	1892		1800brt, 91.7x11.9x3.0m, 4000hp, 16kts; 550mines
			2	Jaguarayo			
			3	Tenente Maria do Couto			340brt; 30mines

© Ivan Gogin, 2015

[home](#)[World navies yesterday](#)[1920](#)

## Bulgaria 01 January 1920

### TORPEDO SHIPS

TB	Vasil Levski	2	1, 2	Vasil Levski, Khristo Botev	1877-1878		20t, 18.3x2.3x1.1m, 1b,1vc, 220hp, 13kts, 9p
	Druzki	4	3	Druzki	1908		100t, 38.0x4.4x1.3m, 2b,1vte, 1950hp, 26kts, 32p; 2x1-47/50, (1+1x2)-450TT(4), sweeps(3,5,6)
			4	Smeli	1908		
			5	Khrabri	1908		
			6	Strogi	1909		

### MINE WARFARE SHIPS



AML	-		1	1	Kamchiya		1883		105t; 12mines
MSB	Konduktor Dokuzanov		8	1-8	Konduktor Dokuzanov, Kapitan-leytenant Minkov, Minyor, Dobrotich, Momchil, Kalatserka, Nesebyr, Emona		1916	No picture	8-18t, 9.0-16.0x2.0-3.0x0.8-1.0m, 1pe, 28-60hp, 7-9kts, 5-8p; sweep

© Ivan Gogin, 2015

[home](#)[World navies yesterday](#)[1920](#)

# Canada 01 January 1920

## SUBMARINES

SS	C	2	1	CC1	1914		313/373t, 44.0(1)-48.0(2)x4.6(1)-4.3(2)x3.4m, 1pe/em, 600/240(1)-600/260(2)hp, 13/10.2kts, 18p, 30m; 5-450TT(1), 3-450TT(2)
			2	CC2	1914		
H1	2	4	3	CH14	1917		364/434t, 45.8x4.7x3.8m, 2d/em, 480/620hp, 13/11kts, 22p, 30m; 4-450TT
			4	CH15	1917		

## ESCORTS

AY	-	1	1	Stadacona	1893	780brt; 1x1-102/40, 1x1-76/40
----	---	---	---	-----------	------	-------------------------------

## MINE WARFARE SHIPS

TL	Ypres	12	1	Arleux	1918	No picture	440t, 39.6ppx7.1x4.1m, 1b,1vte, 10.5kts; 1x1-76/40
			2	Armentiers	1918		
			3	Arras	1918		
			4	Festubert	1917		
			5	Givenchy	1918		
			6	Loos	1918		
			7	Messines	1917		
			8	St. Eloi	1917		
			9	St. Julien	1917		
			10	Thiepval	1918		
			11	Vimy	1917		
			12	Ypres	1917		
			1	CD1	1917		
			2	CD2	1917		
			3	CD3	1917		
			4	CD4	1917		
			5	CD5	1917		
			6	CD6	1917		
			7	CD7	1917		

8	CD8	1917
9	CD9	1917
10	CD10	1917
11	CD11	1917
12	CD12	1917
13	CD13	1917
14	CD14	1917
15	CD15	1917
16	CD16	1917
17	CD17	1917
18	CD18	1917
19	CD19	1917
20	CD21	1917
21	CD22	1917
22	CD23	1917
23	CD24	1917
24	CD25	1917
25	CD26	1917
26	CD27	1917
27	CD28	1917
28	CD29	1917
29	CD31	1918
30	CD32	1918
31	CD33	1918
32	CD34	1918
33	CD37	1918
34	CD38	1918
35	CD39	1918
36	CD40	1918
37	CD42	1918
38	CD43	1918
39	CD44	1918
40	CD48	1918
41	CD49	1918
42	CD51	1918
43	CD52	1918
44	CD53	1917
45	CD54	1918
46	CD55	1918
47	CD56	1918
48	CD57	1918

DF Admiralty wooden

83



175t, 28.7x6.1x2.2m, 1b,1vte, 270hp, 9kts; 1x1-57/40 or 1x1-57/42, sweeps



49	CD58	1918
50	CD59	1918
51	CD60	1918
52	CD62	1918
53	CD63	1918
54	CD64	1918
55	CD66	1918
56	CD68	1917
57	CD69	1917
60	CD70	1918
61	CD71	1917
62	CD72	1917
63	CD73	1917
64	CD74	1917
65	CD75	1917
66	CD76	1918
67	CD77	1918
68	CD79	1918
69	CD80	1918
70	CD81	1918
71	Onyx	1918
72	CD83	1918
73	CD84	1918
74	CD85	1918
75	CD86	1918
76	CD87	1917
77	CD88	1918
78	CD89	1918
79	CD90	1918
80	CD91	1918
81	CD92	1918
82	CD93	1918
83	CD95	1918





[home](#)[World navies yesterday](#)[1920](#)

# Chile 01 January 1920

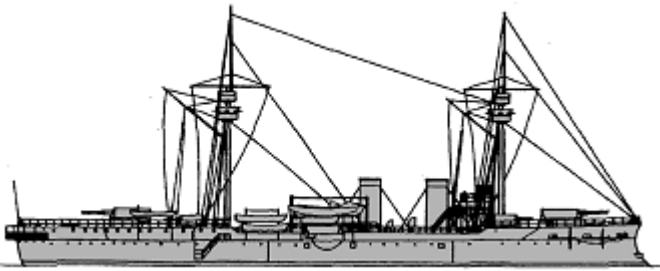
## BATTLESHIPS



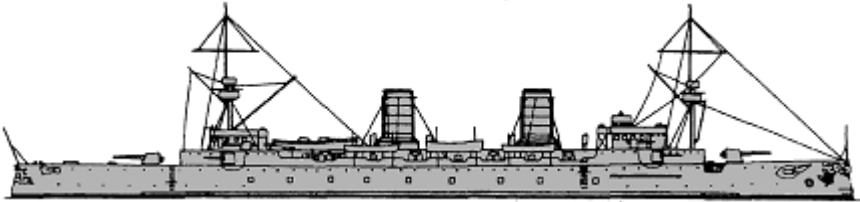
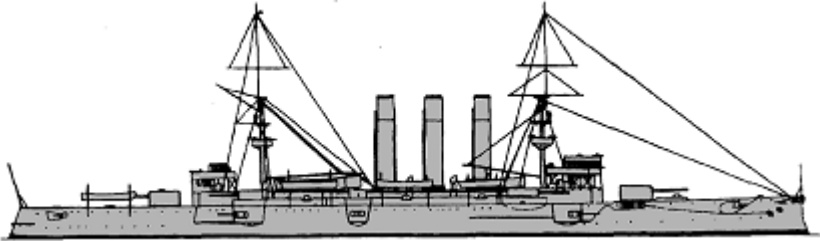

BB	Capitán Prat	1	1	Capitán Prat	1893		6901t, 100.0ppx18.5x7.0m, 12b,2hte, 15000hp, 19.5kts, 480p; steel- 300belt, 50deck, 275barbettes, 265CT; 4x1-240/36, 4x2-120/45, 10x1-57/40, 2-450TT
----	--------------	---	---	--------------	------	--	--

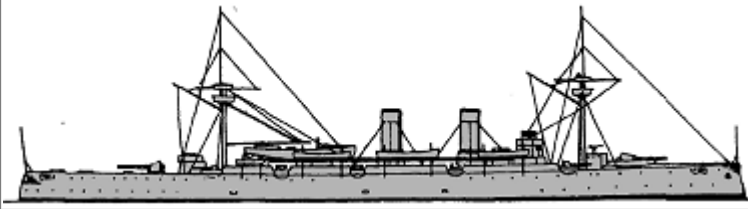
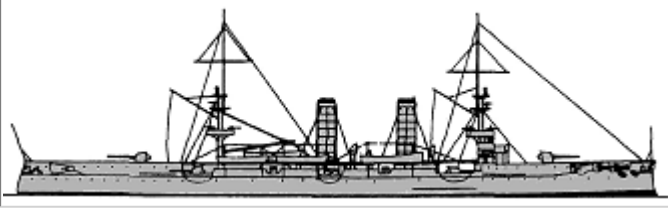
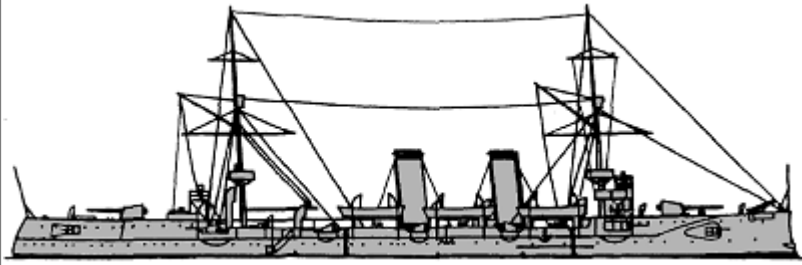
## CRUISERS

CA	Esmeralda	1	1	Esmeralda	1896		7000t, 132.9ppx16.2x6.2m, 12b,2vte, 16000hp, 22.2kts, 500p; Harvey- 152belt, 51deck, 114shields, 203CT; 2x1-203/40, 12x1-152/40, 8x1-76/40, 3-450TT
	O'Higgins	1	2	O'Higgins	1898		8500t, 135.2x19.1x6.7m, 30b,2vte, 16000hp, 21kts, 500p; Harvey- 178belt, 51deck, 178turrets, 229CT; 4x1-203/40, 10x1-152/40, 4x1-120/44, 10x1-76/40, 10x1-57/40, 3-450TT
	Presidente Errázuriz	1	1	Presidente Errázuriz	1892		2047t, 81.8ppx10.9x4.4m, 4b,2hte, 5400hp, 18.3kts, 170p; steel- 60slopes, 35deck, 90shields, 50CT; 4x1-152/45, 2x1-120/45, 4x1-57/40, 3-356TT
	Blanco Encalada	1	2	Blanco Encalada	1894		4568t, 112.8ppx14.2x5.6m, 8b,2vte, 14600hp, 22.8kts, 427p; steel- 102slopes, 44deck, 152shields, 152CT; 2x1-203/40, 10x1-152/40, 12x1-76/40, 12x1-37/20, 5-450TT

CL						
	Ministro Zenteno	1 3	Ministro Zenteno	1898		3437t, 100.6ppx13.3x5.1m, 8b,2vte, 7500hp, 20.2kts, 317p; steel- 89slopes, 32deck, 102CT; 8x1-152/45, 10x1-57/40, 4x1-37/20, 3-450TT
	Chacabuco	1 4	Chacabuco	1902		4877t, 127.5x14.2x5.2m, 8b,2vte, 15700hp, 23kts, 400p; Harvey- 114slopes, 44deck, 114shields, 76CT; 2x1-203/45, 10x1-120/40, 12x1-76/40, 6x1-47/40, 3-450TT

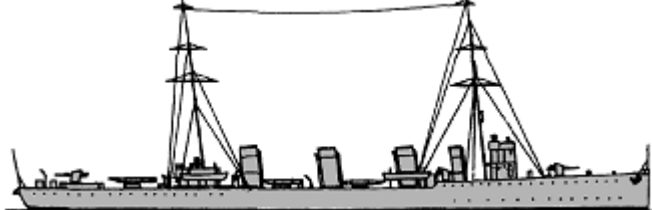
### TORPEDO SHIPS

DD	Capitán Orella	4	1 Capitán Orella 2 Capitán Muñoz Gamero 3 Teniente Serrano 4 Guardiamarina Riquelme	1896 1896 1896 1896		300t, 64.9ppx6.6x1.8m, 4b,2vte, 6250hp, 30kts, 65p; 1x1-76/40, 5x1-57/40, 2x1-450TT
	Capitán Merino Jarpa	3	5 Capitán Merino Jarpa 6 Capitán O'Brien 7 Capitán Thomson	1902 1902 1902		321t, 65.5ppx6.5x1.8m, 4b,2vte, 6250hp, 30kts, 65p; 1x1-76/40, 5x1-57/40, 2x1-450TT
	Almirante Lynch	2	8 Almirante Lynch 9 Almirante Condell	1913 1914		1850t, 100.8x9.9x3.4m, 6b,3st, 30000hp, 31kts, 160p; 6x1-102/40, 4x1-450TT
	Sargente Aldea	1	1 Sargente Aldea	1886	No picture	80t, 38.1x4.0x2.1m, 1b,1vc, 700hp, 20kts, 16p; 2x2-25/42, 2-356TT
TB	Ingeniero Hyatt	6	2 Cirujano Videla	1896		140t, 46.5x4.7x2.4m, 2b,1vte, 2200hp, 27kts, 16p; 3x1-47/40, (1+1x2)-356TT
			3 Ingeniero Mery	1896		
			4 Ingeniero Hyatt	1896		
			5 Teniente Rodriguez	1896		
			6 Ingeniero Mutilla	1898		
			7 Guardiamarina Contreras	1898		

### SUBMARINES

SS	H1	6	1	H1	1915		364/434t, 45.8x4.7x3.8m, 2d/em, 480/620hp, 13/11kts, 22p, 30m; 4-450TT
			2	H2	1915		
			3	H3	1915		
			4	H4	1916		
			5	H5	1916		
			6	H6	1916		

## ESCORTS

PC	Yelcho	1	1	Yelcho	1908	No picture	467t, 39.0x7.0x2.9m, 1vte, 350hp, 12kts; 1x1-37/20
----	--------	---	---	--------	------	------------	--

© Ivan Gogin, 2015

[home](#)[World navies yesterday](#)[1920](#)

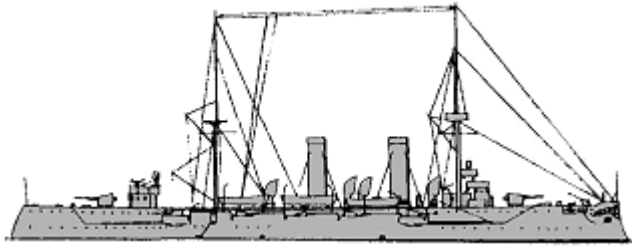
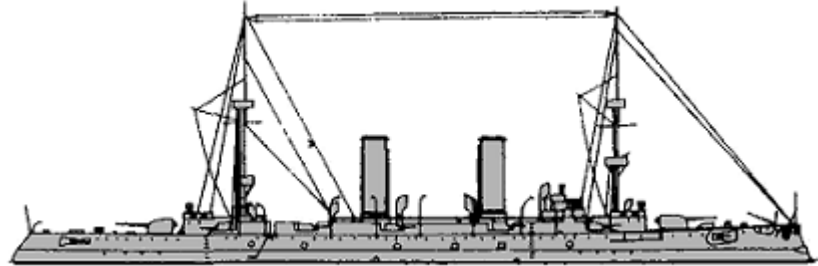
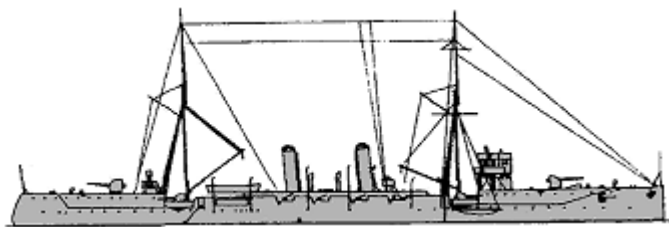
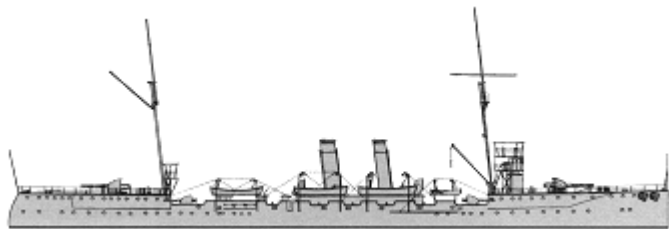
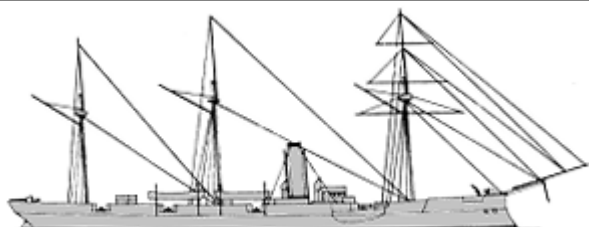

# China 01 January 1920

## CRUISERS

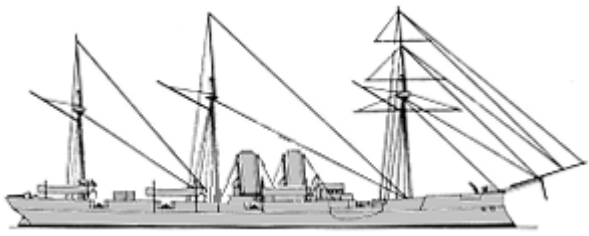
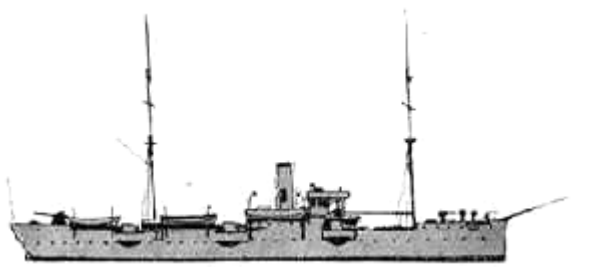
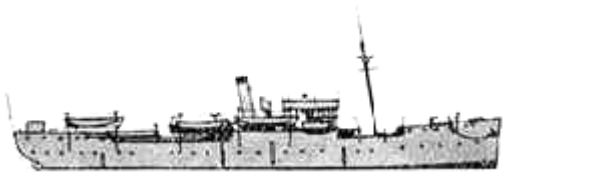
CL	Hai Yung	1	Hai Yung	1898		2950t, 100.0x12.4x5.8m, 8b,2vte, 7500hp, 19.5kts, 244p; 70slopes, 32deck, 51shields, 37CT; 3x1-149/37, 8x1-105/37, 6x1-47/37, 3-356TT	
		2	Hai Chou	1898			
		3	Hai Chen	1898			
	Hai Chi	1	4	Hai Chi	1899		4515t, 129.2x14.2x5.5m, 12b,4vte, 17000hp, 24kts, 350p; Harvey- 127slopes, 37deck, 114turrets, 152CT; 2x1-203/45, 10x1-120/45, 16x1-47/40, 5-450TT
	Ying Swei	1	5	Ying Swei	1911		2500t, 105.0x11.9x4.0m, 6b,3st, 6000hp, 20kts, 270p; 37slopes, 25deck, 76CT; 2x1-152/50, 4x1-102/50, 4x1-76/50, 6x1-76/40, 2x1-37/27, 2x1-450TT
Chao Ho	1	6	Chao Ho	1912		2750t, 105.5x12.8x4.5m, 8b,3st, 6000hp, 20kts, 283p; 51slopes, 25deck, 76CT; 2x1-152/50, 4x1-102/50, 4x1-76/50, 6x1-47/40, 2x1-37/27, 2x1-450TT	
Kai Che	1	1	King Ch'ing	1886		2100t, 76.2x11.0x5.5m, 8b,1hte, 2400hp, 16kts, 300p; steel- casemates; 3x1-178/26, 7x1-121/22, 2-356TT	

CLL	Nan Thin	1	2	Nan Shui	1884		2200t, 84.0x11.0x5.5m, 8b,1hc, 2400hp, 15kts, 250p; 2x1-209/20, 8x1-120/32, 10x4-25/42, 1-356TT
	Tung Chi	1	3	Tung Chi	1896		1900t, 77.0ppx10.4x4.9m, 4b,1vc, 1600hp, 11.6kts, 335p; 2x1-152/40, 5x1-120/45, 3x1-57/40, 8x1-37/20
	Fu An	1	4	Fu An	1897		1700t, 76.8ppx11.6x5.5m, 4b,1vc, 1600hp, 10kts, 105p; 2x1-57/40

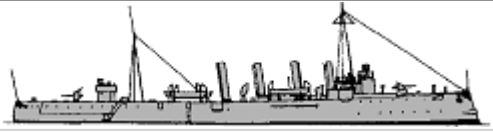
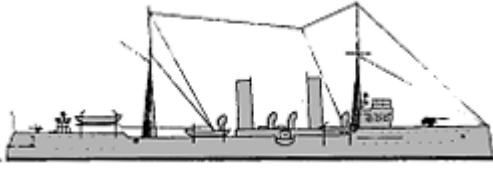

## TORPEDO SHIPS

PGT	Fei Ying	1	1	Fei Ying	1896		850t, 75.0x8.6x4.0m, 8b,2vte, 5430hp, 22kts, 90p; 25deck, 50shields; 2x1-105/37, 6x1-57/40, 4x1-37/20, (1+2x1)-356TT
	Chien Wei	2	2	Chien Wei	1903		900t, 79.2x8.1x3.5m, 4b,2vte, 6500hp, 20.5kts, 140p; steel- 25belt, 25deck; 1x1-100/44, 3x1-65/50, 6x1-37/27, 2x1-356TT
			3	Chien An	1903		
DD	Chang Feng	3	1	Yu Chang	1911		390t, 60.4x6.5x1.8m, 4b,2vte, 6500hp, 32kts, 69p; 2x1-76/40, 2x1-47/40, 2x1-450TT
			2	Chien Kang	1912		
			3	Tung An	1912		
TB	Lei Fu	2	1, 2	Lei Fu, Lei Lung	1884	No picture	64t, 35.0x4.0x1.7m, 2b,1vte, 700hp, 19.8kts, 20p; 2x5-37/17, 2-356TT
	Lei Chen	9	3- 11	Lei Chen, Lei Chung, Lei Kong, Lei Kwong, Lei Kung, Lei Li, Lei Sun, Lei Tsen, Lei Tui	1885	No picture	27t, 26.0x3.6m, 1b,1vc, 420hp, 19.5kts; 1-356TT
	Chang Tze	2	12, 13	No1 Chang Tze, No3 Lieh Tze	1895	No picture	89t, 39.0x4.8x1.5m, 1b,1vc, 600hp, 18kts, 31p; 2x5-37/17, (2+1x1)-356TT
	Chen Tse	2	14	No2 Chen Tse	1896		126t, 43.9x5.2x2.4m, 2b,1vte, 1000hp, 18kts, 31p; 2x5-37/17, (2+1x1)-450TT
			15	No4 Su Tse	1896		
	Hu Peng	4	16	No7 Hu Peng	1906		120t, 41.1x4.9x2.1m, 2b,1vte, 1200hp, 23kts, 34p; 2x1-47/40, (1+2x1)-450TT
17			No8 Hu Oah	1906			
18			No9 Hu Ying	1907			



		19	No10 Hu Chen			1907

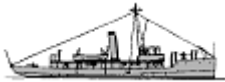







## ESCORTS

PC	Yi Sheng	1	1	Yi Sheng	1911		350t, 36.7x6.3x3.4m, 1b,1vte, 500hp, 10kts, 37p; 1x1-65/50, 1x1-57/40
	Hai Yen	1	2	Hai Yen	1917	No picture	60t, 19.8x3.7x0.7m, 1b,2vte, 60hp, 10kts; 1x1-37/27
	Hai Ku	2	3	Hai Ku	1917		200t, 34.1x5.5x2.6m, 1b,2vte, 300hp, 10.5(3)-11(4)kts, 22p; 2x1-37/27
			4	Hai Hung	1917		
	Hai Fu	2	5	Hai Fu	1917		166t, 33.2x5.2x2.4m, 1b,1vte, 220hp, 10.5kts, 22p; 1x1-37/27
			6	Hai Ou	1917		
Hai Hao	1	7	Hai Hao	1917		230t, 32.3x5.5x2.0m, 1b,1vte, 200hp, 12kts, 22p; 4x1-37/27	

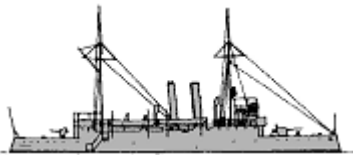
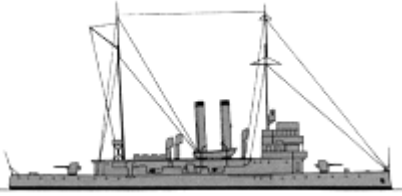
## OTHER FIGHTING SHIPS

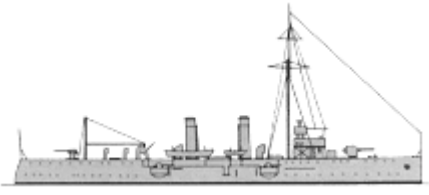
Kwangtung	2	1	An Lan	1868	No picture	440t, 42.7x7.2x2.7m, 3b,1hr, 255hp, 9.3kts, 60p; 1x1-178/16, 2x1-121/22
		2	Chen T'ao	1868		
Fei Ting	2	3	Fei Ting	1876		420t, 36.6x9.1x2.4m, 1b,2hcr, 270hp, 9.5kts, 30p; iron- 13shield, 13CT; 1x1-318/16, 2x1-70/22, 1x4-25/42
		4	Tse Tien	1876		
Hai Ch'ang Ch'ing	1	5	Hai Ch'ang Ch'ing	1877		430t, 38.1x9.1x2.4m, 1b,2hcr, 70hp, 7.5kts; 1x1-279/12, 2x1-76/28
Kuang Yuan	4	6	Kuang Yuan	1886	No picture	300t, 33.8x5.5x2.3m, 2hrcr, 65-78hp, 9-10kts; 1x1-149/32, 1x1-88/32, 3x1-37/42
		7	Kuang Heng	1886		
		8	Kuang Li	1886		
		9	Kuang Chien	1886		
Kuang Keng	4	10	Kuang Keng	1887	No picture	560t, 43.0x7.3x3.7m, 1vr, 400hp, 11kts; 2x1-121/22, 1x1-100/22, 2x1-47/40
		11	Kuang Hsing	1887		
		12	Kuang Jen	1887		
		13	Kuang Kuei	1887		
Chen Sheng	1	14	Chen Sheng	1899	No picture	275t, 36.6x6.1x2.1m, 1vc, 400hp, 10kts, 42p; 1x1-76/40, 1x1-57/40
		15	Kiang Yuan	1905		

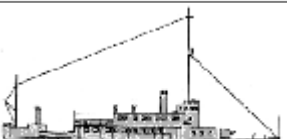

PG	Kiang Yuan	4	16	Kiang Heng	1907		565t, 54.1x8.5x2.1m, 2b,2vte, 950hp, 13kts, 85p; 1x1-120/40, 1x1-76/40, 4x1-47/40
			17	Kiang Li	1907		
			18	Kiang Chen	1907		
			19	Chu Tung	1906		
	Chu Tung	6	20	Chu Chien	1906		752t, 61.0x9.0x2.4m, 2b,2vte, 1350hp, 13kts, 117p; 2x1-120/40, 2x1-76/40
			21	Chu Tai	1906		
			22	Chu Yu	1907		
			23	Chu Yiu	1907		
			24	Chu Kuan	1907		
			25	Kuan Chuan	1908		
	26	An Feng	1908	No picture	169t, 37.2x5.6x1.7m, 1b,1vc, 350hp, 12.1kts		
	27	Lien Ching	1911	No picture	500t, 53.3x7.6x2.9m, 2b,2vte, 925hp, 13.5kts, 60p; 4x1-47/40		
	28	Wu Feng	1912	No picture	200t, 37.8x6.1x2.1m, 1b,1vte, 300hp, 10kts, 46p; 4x1-47/40		
Yung Feng	2	29	Yung Feng	1913		1020t, 65.8x9.0x2.4m, 2b,2vte, 1350hp, 13kts, 108p; 25deck; 1x1-105/37, 1x1-76/50, 4x1-47/40, 2x1-37/27	
		30	Yung Hsiang	1913			
Yung Chien	2	31	Yung Chien	1915		1039t, 65.7x9.0x3.5m, 2b,2vte, 1350hp, 13kts, 105p; 25deck; 1x1-102/50, 1x1-76/40, 4x1-47/40, 2x1-37/27	
		32	Yung Chi	1916			
PGR	Chian Kung	4	1	Chian Kung	1909		200t, 44.0x6.0x2.3m, 1b,2vte, 500hp, 14kts, 62p; 1x1-76/40
			2	Chiang Chi	1909		
			3	Chiang Ku	1909		
			4	Chiang Tai	1909		
	Chiang Hsi	2	5	Chiang Hsi	1912		140t, 43.9(5)-44.5(6)x7.5(5)-7.3(6)x0.6m, 2b,2vte, 450(5)-500(6)hp, 12kts, 49p; 1x1-88/11
			6	Chiang Kun	1912		
	Chien Chung	3	7-9	Chien Kung, Yung An, Kung Chen	1915-1916	No picture	90t, 35.5x5.6x0.6m, 1b,2vte, 450hp, 11kts, 42p; 1x1-88/11
Li Sui	1	10	Li Sui	1904		280t, 50.1x8.0x0.9m, 2b,2vte, 1300hp, 13kts, 58p; 1x1-88/27, 1x1-50/37	
Li Chieh	1	11	Li Chieh	1910		314t, 54.1x8.7x0.8m, 2b,2vte, 1300hp, 13kts, 58p; 2x1-52/51	

## CUSTOMS FLOTILLAS

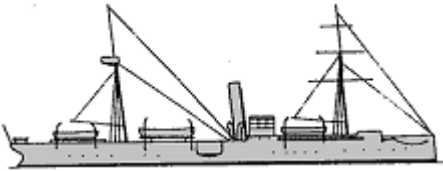
CGC	Fee Cheu	1	1	Fee Cheu	1887		1300t, 67.1x9.8x4.0m, 13kts; 2x1-152/26
	Chuen Tiao	1	2	Chuen Tiao	1888	No picture	716t, 47.3x7.6x3.5m, 10kts; 2x1-95/21, 2x1-47/40
	Likin	2	3	Likin	1888	No picture	512t, 41.2x7.0x3.5m, 10kts; 2x1-95/21, 2x1-47/40
			4	Kaipan	1888		
Liu Hsing	1	5	Liu Hsing	1902	No picture	1500t, 59.2x8.4m	

© Ivan Gogin, 2015

[home](#)[World navies yesterday](#)[1920](#)

# Cuba 01 January 1920

## OTHER FIGHTING SHIPS

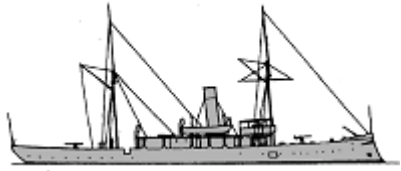
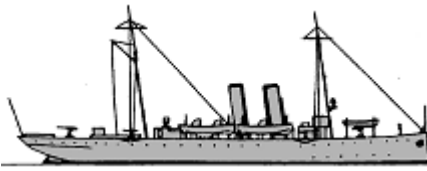
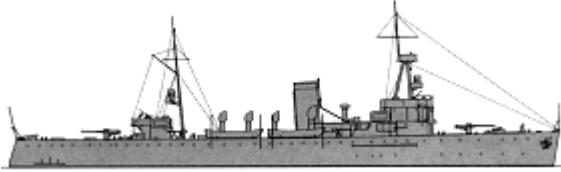
PG	Baire	1	1	Baire	1906		510t, 59.7x7.0x2.7m, 1vte, 1200hp, 14kts, 76p; 4x1-76/50, 2x1-37/40
	Santa Clara	1	2	Santa Clara	1911	No picture	52t, 32.0x1.8m, 12kts, 17p; 1x1-37/40
	Diez de Octubre	2	3	Diez de Octubre	1911	No picture	218t, 33.6x6.1x2.4m, 1vte, 12kts, 39p; 3x1-47/40
			4	Veinte y Cuatro de Febrero	1911		
	Patria	1	5	Patria	1911		1200t, 61.0ppx11.0x4.0m, 2vte, 4000hp, 16kts, 115p; 4x1-57/40, 4x1-47/40
	Cuba	1	6	Cuba	1911		2055t, 79.2x11.9x4.3m, 2vte, 6000hp, 18kts, 145p; 2x1-102/50, 4x1-57/40, 4x1-47/40, 4x1-37/40
	Habana	2	7, 8	Habana, Pinar del Río	1912	No picture	80t, 30.5x5.5x1.3m, 1vte, 200hp, 12kts, 20p; 1x1-37/40
General Juan Bruno Zayas	1	9	General Juan Bruno Zayas	1914	No picture	300t, 50.0x3.4m, 11kts, 51p; 2x1-37/40	

## COASTAL FORCES

PS	CS1	4	1-4	CS1-4	1918		85t, 33.5x4.5x1.7m, 3pe, 660hp, 18kts, 27p; 1x1-76/23, 1dct
----	-----	---	-----	-------	------	---	---

## COAST GUARD SHIPS

	Veinte de Mayo	1	1	Veinte de Mayo	1895	No picture	203t, 45.7x5.6x3.2m, 500hp, 12kts, 43p; 2x1-47/40, 2x1-37/40
	Yara	1	2	Yara	1895	No picture	449t, 47.2x7.9x4.0m, 600hp, 12kts, 53p; 2x1-57/40, 2x1-47/40

CGC	Alfredo	1	3	Alfredo	1896	No picture	40t, 18.3x3.7x1.8m, 11kts; 1x1-37/40
	Maceo	3	4-6	Maceo, Céspedes, Argamonte	1896	No picture	35t, 22.9x3.1x1.7m, 10kts; 1x1-37/40
	Enrique Villuendas	1	7	Enrique Villuendas	1899	No picture	178t, 40.2x6.1x2.7m, 600hp, 16kts; 2x1-47/40
	Matanzas	2	8, 9	Matanzas, Las Villas	1912	No picture	80t, 30.5x5.5x1.3m, 1vte, 200hp, 12kts, 20p; 1x1-37/40

© Ivan Gogin, 2015

[home](#)[World navies yesterday](#)[1920](#)

## Denmark 01 January 1920

### BATTLESHIPS

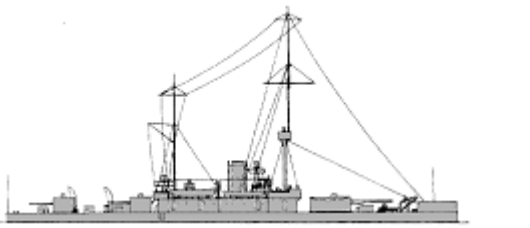
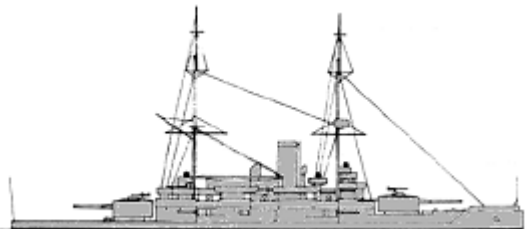





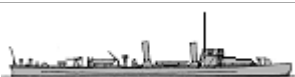

BC	Skjold	1	1	Skjold	1897		2195t, 69.4x11.6x4.2m, 4b,2vte, 2400hp, 14kts, 138p; Harvey- 229belt, 50deck, 250turret; 1x1-240/37, 3x1-120/38, 4x1-57/40
	Herluf Trolle	3	2	Herluf Trolle	1901		3650(2)-3700(3)-3785(4)t, 86.5(2,3)-87.4(4)x15.1(2)-15.4(3)-15.7(4)x5.0m, 6b,2vte, 4200(2,3)-5400(4)hp, 15.5(2,3)-16(4)kts, 258p; steel(2)- 195belt, 65deck, 175(2)-190(3,4)turrets, 190CT; 2x1-240/42(3,4), 2x1-240/38(2), 4x1-149/49(4), 4x1-149/42(2,3), 6x1-75/52(2,3), 10x1-75/52(4), 2x1-57/40(2,3), 8x1-37/20(2), 2x1-37/20(4), 3-450TT(2,3), 4-450TT(4)
			3	Olfert Fischer	1905		
			4	Peder Skram	1908		

### CRUISERS

CL	Valkyrien	1	1	Valkyrien	1890		3020t, 85.8x13.2x5.5m, 6b,2vte, 5200hp, 17kts, 282p; steel- 65deck; 2x1-149/49, 6x1-75/52, 2x1-57/40, 2x5-37/17, 3-381TT
	Gejser	2	2	Gejser	1893		1282(2)-1342(3)t, 72.3x10.4x3.5m, 8b,2vte, 3000hp, 17kts, 156p; steel- 50(2)-45(3)deck; 2x1-120/38, 4x1-87/37, 4x1-57/40, 1-450TT, 3-381TT
			3	Hejmdal	1895		
CLL	Ingolf	1	1	Ingolf	1878	No picture	1012t, 63.9x8.5x4.2m, 630hp, 10.2kts, 156p; 4x1-57/40

### TORPEDO SHIPS

	Nordkaperen	2	1	T6	1894		127t, 42.5x4.3x2.2m, 2b,1vc, 1300hp, 19kts, 20p; 2x5-37/17, 2-450TT, 1x2-381TT
--	-------------	---	---	----	------	--	--

TB1cl		2	T7	1893			
	Hajen	1 3	Hajen	1896		141t, 42.9x4.6x2.5m, 2b,2vte, 2000hp, 22kts, 25p; 1x1-47/40, 1x5-37/17, 2-450TT, 1x2-381TT	
	Havørnen	2	4	Havørnen	1897		142t, 44.4x4.7x2.4m, 2b,2vte,2 100hp, 22kts, 25p; 1x1-47/40, 1x5-37/17, (2+1x2)-450TT
			5	Søbjørnen	1898		
	Ormen	1 6	Ormen	1907		105t, 38.0x4.3x2.6m, 2b,1vte, 2100hp, 26.2kts, 21p; 2x1-37/40, (1+1x2)-450TT	
	Tumleren	3	7	Tumleren	1911		271t, 56.4x5.8x2.2m, 2b,1st, 5000hp, 27.5kts, 33p; 2x1-75/52, (1+4x1)-450TT
			8	Vindhunden	1912		
			9	Spækhuggeren	1912		
	Søridderen	3	10	Søridderen	1911		295t, 55.4x5.5x2.0m, 2b,1st, 5000hp, 27.5kts, 33p; 2x1-75/52, (1+4x1)-450TT
			11	Flyvefisken	1911		
			12	Sølulven	1911		
	Hvalrossen	3	13	Hvalrossen	1913		182t, 45.2x5.2x2.1m, 2b,2vte, 3500hp, 26.3kts, 30p; 1x1-75/52, (1+1x2+1x1)-450TT
			14	Delfinen	1914		
			15	Sværdfisken	1914		
	Springeren	8	16	Springeren	1917		109t, 38.5x4.3x2.7m, 2b,1vte, 2000hp, 24.6kts, 24p; 2x1-57/40, (1+1x1)-450TT
			17	Støren	1917		
			18	Søløven	1917		
			19	Søhunden	1917		
			20	Havhesten	1917		
			21	Narhvalen	1917		
			22	Makrelen	1918		
			23	Nordkaperen	1918		
	TB2cl	P8	2 1, 2	P8, 9	1894-1895	No picture	48t, 25.6x3.8x1.8m, 1vte, 330hp, 13kts, 13p; 1x1-47/40, 1x5-37/17, 1x1-356TT
P4		4 3-6	P4-7	1889-1890	No picture	20t	

## SUBMARINES

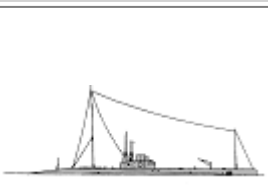
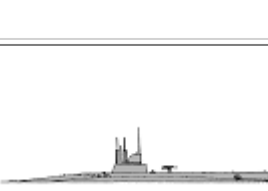
SS	Havmanden	6	1	Havmanden	1912		164/204t, 38.8x3.6x2.3m, 1d/em, 430(2,4,5)-450(3,6,7)/270(2,4,5)-275(3,6,7)hp, 13/10kts, 10p; 2-450TT
			2	Havfruen	1913		
			3	Thetis	1912		
			4	2den April	1913		
			5	Najaden	1913		
			6	Nymfen	1914		
	Ægir	5	7	Ægir	1915		185/235t, 40.6x3.7x2.4m, 1d/em, 450/340hp, 13.5/9.8kts, 11p; 1x1-57/40, 3-450TT
			8	Ran	1915		
			9	Triton	1916		
			10	Neptun	1916		

## OTHER FIGHTING SHIPS

PG	Grønsund	1	1	Guldborgsund	1885	No picture	268t, 36.3x6.1x2.5m, 400hp, 10.5kts, 46-49p; 2x1-47/40
----	----------	---	---	--------------	------	------------	--

## MINE WARFARE SHIPS

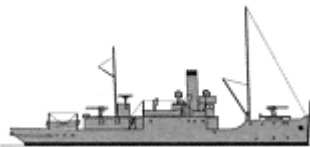
ML	Hjælperen	1	1	Hjælperen	1891	No picture	288t, 38.3x6.8x2.3m, 330hp, 25p; 3x5-37/17, mines
	Lossen	1	2	Lossen	1911		640t, 48.6x8.5x3.1m, 2b,2vte, 900hp, 13kts, 53p; 2x1-57/40, 180mines
	Minekran Nr.V	2	3	Minekran Nr.V	1917	No picture	186t, 27.0x6.3x2.0m, 2dg,2em, 290hp, 8kts, 26p; 2x1-37/38, 60mines
4			Minekran Nr.VI	1919			



## FISHING PROTECTION VESSELS

FPV	Beskytteren	1	1	Beskytteren	1900		415t, 43.4x7.6x3.8m, 2b,1vte, 625hp, 11kts, 47p; 1x1-47/40, 2x1-37/20
	Islands Falk	1	2	Islands Falk	1906	No picture	760t, 56.0x8.9x5.2m, 2b,1vte, 1100hp, 13kts, 63p; 2x1-75/52, 2x1-47/40
	Diana	1	3	Diana	1917	No picture	288t, 35.5x6.6x3.0m, 400hp, 10.5kts, 27p; 2x1-47/40
AFPV	-	2	1	Absalon	1911		297t
			2	Fenris	1915		148t

[home](#)[World navies yesterday](#)[1920](#)

## Ecuador 01 January 1920

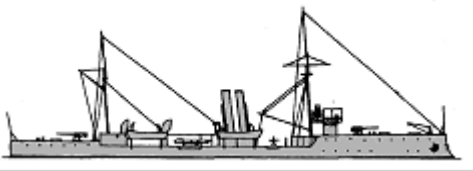
### TORPEDO SHIPS

PGT	Libertador Bolívar	1	1	Libertador Bolívar	1896		800t, 73.2ppx8.4x4.3m, 4b,2vte, 4500hp, 21.5kts; steel- 25deck, 51CT; 2x1-120/40, 4x1-47/40, (1+2x1)-450TT
TB	Tungurahua	1	1	Tungurahua	1890s		65t

### ESCORTS

AY	-	1	1	Cotopaxi	1884	300t; 4x1-76/40
----	---	---	---	----------	------	-----------------

© Ivan Gogin, 2015



[home](#)[World navies yesterday](#)[1920](#)

# Egypt 01 January 1920

## ESCORTS

PC	Noor El Bahr	1	1	Noor El Bahr	1884		450t
	Nesim	1	2	Nesim	1885	No picture	81t
	Marda	1	3	Marda	1886	No picture	154t
	Zarif	1	4	Zarif	1886	No picture	144t
	Saria	1	5	Saria	1886	No picture	71t
APC	-	1	1	Abdul Monaym	1902		610t

## OTHER FIGHTING SHIPS

PGR	Tamai	3	1-3	Hafir, Metemmeh, Abu Klea	1884-1885	No picture	74t, (stw); 1x1-76/40
	El Zafir	3	4	El Zafir	1896	No picture	128t, (stw); 1x1-76/40
			5	El Fateh	1897		
			6	El Nasir	1897		
	Sultan	3	7	Sheik	1896	No picture	140t; 1x1-76/40
			8	Sultan	1896		
			9	Melik	1897		

© Ivan Gogin, 2015



[home](#)[World navies yesterday](#)[1920](#)

## Estonia 01 January 1920

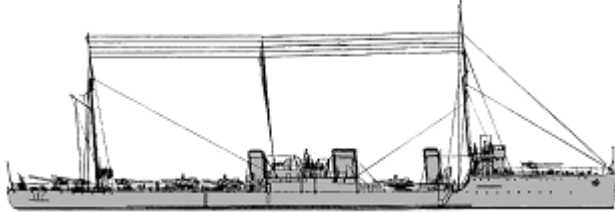
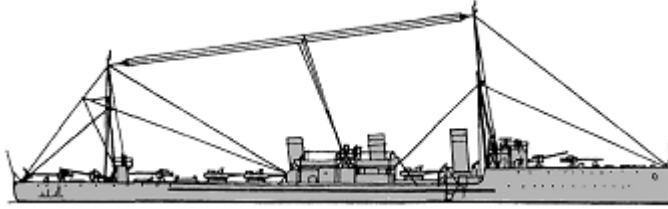
### TORPEDO SHIPS

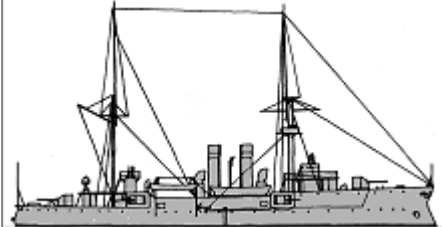

DD	Wambola	1	1	Wambola	1917		1450t, 98.0x9.3x3.9m, 4b,2st, 31500hp, 34kts, 150p; 4x1-102/60, 1x1-40/39, 3x3-450TT, 80mines
	Lennuk	1	2	Lennuk	1917		1570t, 107.0x9.5x4.1m, 5b,2st, 32700hp, 35kts, 150p; 5x1-102/60, 1x1-76/27, 3x3-450TT, 80mines

### OTHER FIGHTING SHIPS

PG	Lembit	1	1	Lembit	1907		1200t, 66.5x11.0x2.2m, 4b,2vte, 800hp, 12kts, 148p; 2x1-120/43, 4x1-75/48, 40mines
	Laine	1	2	Laine	1913		211t, 37.0x6.1x1.8m, 1b,1vte, 500hp, 12kts, 20p; 2x1-76/27
APGR	-	4	1	Ahti	1908		115t
			2	Taara	1913		200t; 3x1-75/48
			3	Tartu	1897		110t
			4	Wanemune	1914		200t; 2x1-75/48

### MINE WARFARE SHIPS

	Kalev	2	1, 2	Kalev, Tahkona	1914		34t, 20.7x5.0x1.2m, 2sd, 60hp, 7.2kts, 8p; 25mines, sweeps
--	-------	---	------	----------------	------	--	--

MLB							
	Olev	2	3, 4	Olev, Lehtma	1916-1917		46t, 23.2x5.0x1.1m, 2sd, 60hp, 7.2kts, 8p; 40mines, sweeps

### BOARD GUARD SHIPS



ABGS	-	1	1	Kou	1909		100t
------	---	---	---	-----	------	--	------

© Ivan Gogin, 2015

[home](#)[World navies yesterday](#)[1920](#)

# Finland 01 January 1920

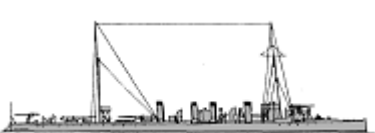
## TORPEDO SHIPS

DD	S1	5	1	S1	1902		305t, 58.5(1)-57.9(2,4,5)-60.7(30x5.7x2.3m, 4b,2vte(1,2,4)-8b,2vte(3,5), 3800hp, 26.5-27.5kts, 58p; 2x1-75/48, 10mines, sweeps
			2	S2	1902		
			3	S3	1900		
			4	S4	1902		
			5	S5	1902		
TB	S6	1	1	S6	1902		204t, 53.5x5.3x1.6m, 4b,2vte, 3800hp, 24kts, 26p; 2x1-47/40
			2	C1	1903		
	C1	4	3	C2	1903		152t, 45.1x4.7x2.7m, 2b,2vte, 3700hp, 29kts, 28p; 2x1-47/40
			4	C3	1903		
			5	C4	1903		

## ESCORTS



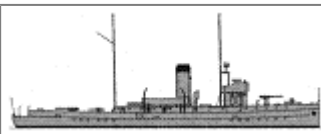

PC	Klas Horn	2	1	Clas Horn	1892		432t, 60.2x7.4x3.4m, 2b,1vte, 3500hp, 21-22.5kts, 65p; 2x1-102/60(1), 2x1-75/48(2)
			2	Matti Kurki	1892		

## OTHER FIGHTING SHIPS

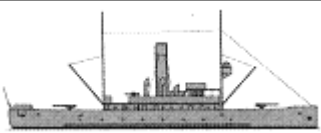
PG	Karjala	2	1	Karjala	1918		342t, 50.1x6.8x2.3m, 2b,2vte, 1150hp, 15kts, 48p; 2x1-75/48, 1x1-40/39, 30mines
			2	Turunmaa	1918		

## MINE WARFARE SHIPS

ML	M1	1	1	M1	1916		776t, 50.0x8.0x2.7m, 3b,1vte, 800hp, 12kts, 46p; 2x1-75/48, 150mines
----	----	---	---	----	------	--	--

MLB	T15	3	1-3	T15, 16, 21	1914		60t, 20.7x5.0x1.2m, 2sd, 60hp, 7.2kts, 8p; 30mines
	T17	2	4, 5	T17, 22	1916		80t, 23.2x5.0x1.1m, 2sd, 60hp, 7.2kts, 8p; 45mines
MS	T1	2	1	T1	1918		220t, 43.6x6.1x1.7m, 2b,2vte, 400hp, 11kts, 35p; 1x1-75/48, 1x1-47/40, sweeps
			2	T2	1917		
MSB	A8	41	1-41	A8, 9, 11-27, 29-45, MP1-5	1916-1917	No picture	9-20t, 15-19.8x3.3-3.6x1.0-1.2m, 1pe, 8-12kts; (0-1)x1-47/40, sweeps
	AF	5	42-46	AF1-5	1917-1918		25t, 15.3x3.5m, 1pe, 50hp, 9kts, 8p; sweeps
	BVA	4	47-50	BVA, BVB, BVC, BVD	1910		25t, 22.2x3.1x0.5m, 2pe, 200hp, 14.5kts, 12p; 8belt, 8deck, 8CT; 1x1-76/14, sweeps

© Ivan Gogin, 2015

[home](#)[World navies yesterday](#)[1920](#)

# France 01 January 1920

## BATTLESHIPS

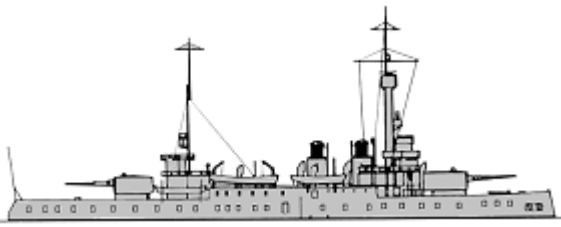
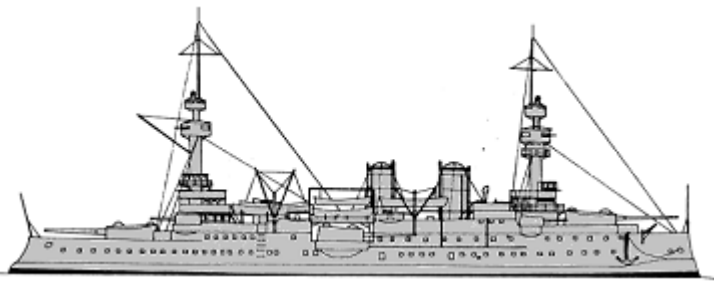
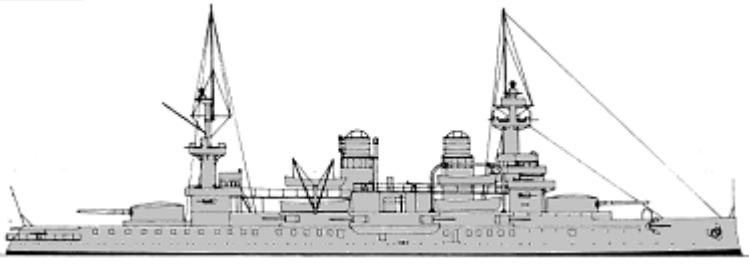
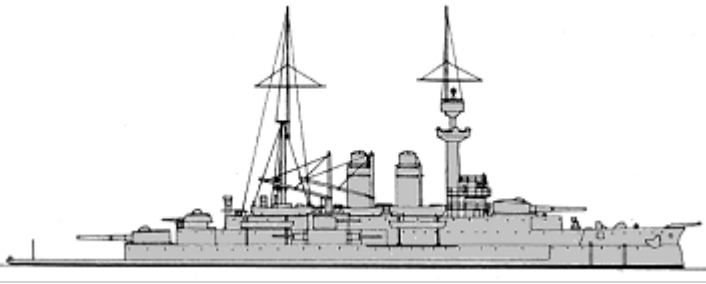
Terrible	1	1	Requin	1888		7530t, 85.3x18.0x8.0m, 12b,2vte, 11200hp, 15kts, 373p; compound-500belt, 105deck, 450barbettes, 30CT; 2x1-274/40, 6x1-100/45, 14x1-47/40
Jauréguiberry	1	2	Jauréguiberry	1897		11637t, 111.9x22.2x8.4m, 24b,2vte, 14400hp, 17.7kts, 631p; nickel steel- 450belt, 70deck, 380turrets, 230CT; 2x1-305/45, 2x1-274/45, 4x2-139/45, 4x1-65/50, 18x1-47/40, 8x5-37/20, 2-450TT
Charlemagne	2	3	Charlemagne	1897		11300t, 117.7x20.2x8.4m, 20b,3vte, 15000hp, 18kts, 694p; Harvey-400belt, 90deck, 380turrets, 330CT; 2x2-305/40, 10x1-139/45, 8x1-100/45, 20x1-47/40, 4x1-37/20, 2-450TT
		4	Saint-Louis	1900		
Henry IV	1	5	Henry IV	1903		8948t, 108.0x22.2x7.0m, 12b,3vte, 11000hp, 17kts, 464p; Harvey-280belt, 80deck, 300turrets, 240CT; 2x1-274/40, 7x1-139/45, 12x1-47/40, 2x1-37/20, 2-450TT
		6	République	1906		14605(6)-14900(7)t, 134.8x24.3x8.4m, 24b,3vte, 18000hp, 19kts,

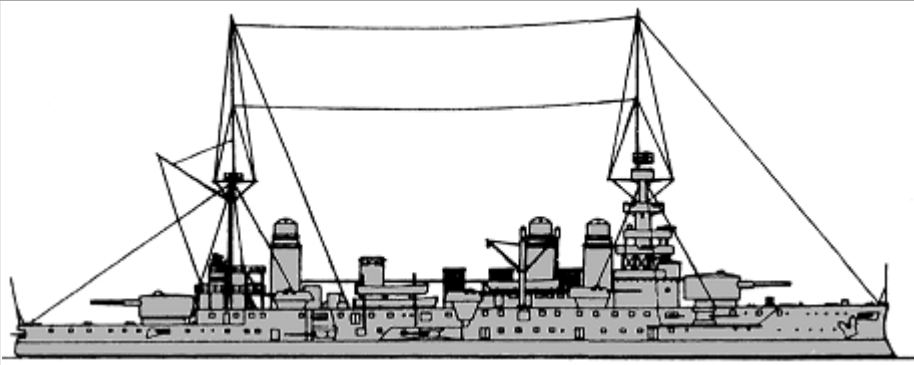
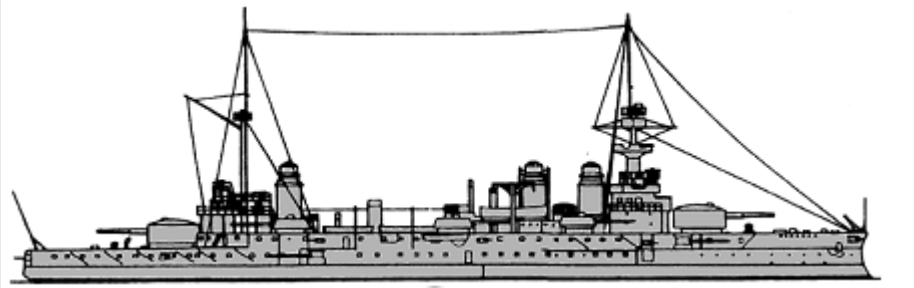
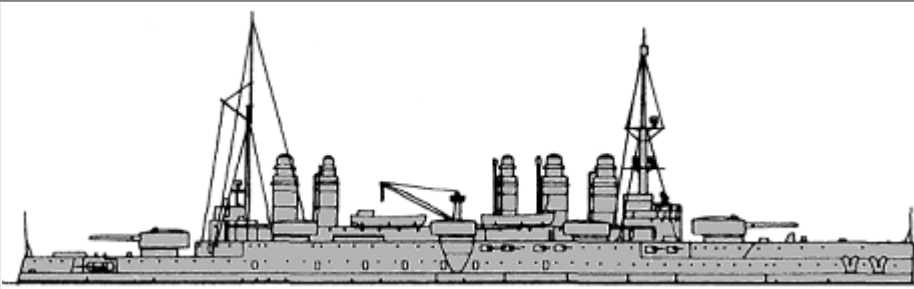
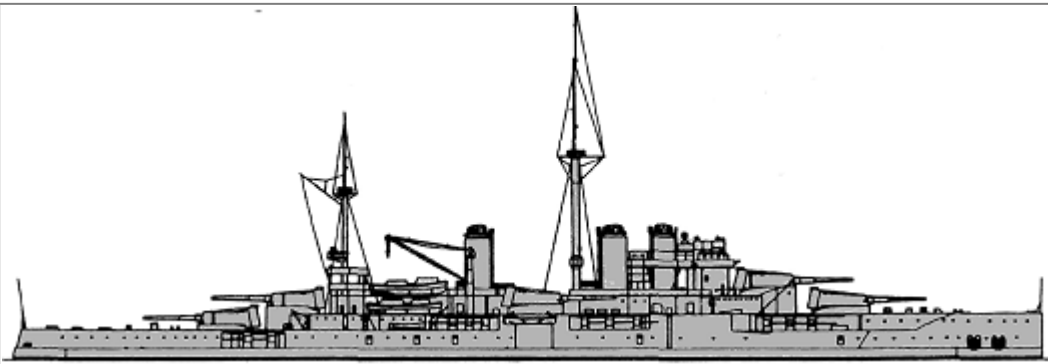
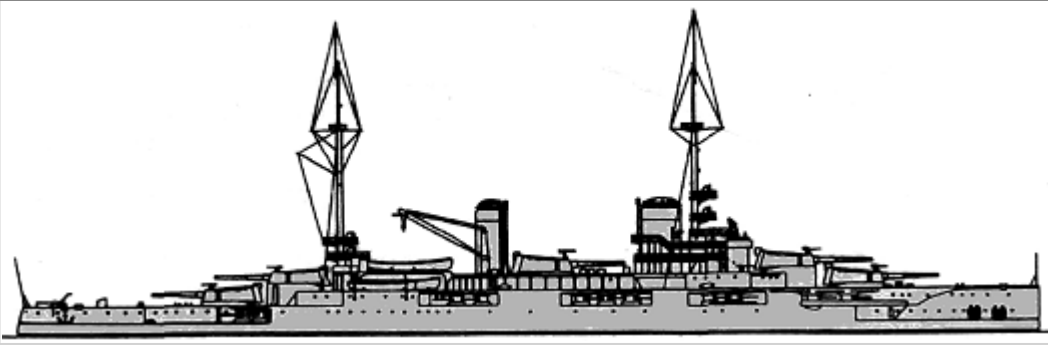
BB	République	2	Patrie	1906		825p; 280belt, 55deck, 360turrets, 300CT; 2x2-305/40, (6x2+6x1)-165/45(6), 6x2-165/45(7), 25x1-47/50, 2-450TT
		7				
	Démocratie	8	Démocratie	1908		14489-14860t, 134.8x24.3x8.4m, 22b,3vte(15,17)-24b,3vte(16), 18500hp, 19kts, 769p; 280belt, 55deck, 360turrets, 300CT; 2x2-305/40, 10x1-194/50, 13x1-65/50, 8x1-47/50, 2-450TT
		9	Justice	1908		
		3	10	Verité		
	Danton	11	Condorcet	1911		19763t, 146.6x25.8x9.2m, 26b,4st, 22500hp, 19.2-19.4kts, 681p; 270belt, 93deck, 300turrets, 300CT; 2x2-305/45, 6x2-240/50, 28x1-75/63, 10x1-47/50, 2-450TT
12		Diderot	1911			
13		Mirabeau	1911			
5		14	Vergniaud	1911		
15		Voltaire	1911			
Courbet	24	Courbet	1913		25000-26000hp, 168.0x27.9x9.0m, 26b,4st, 28000hp, 20kts, 1085-1108p; 270belt, 70deck, 320turrets, 300CT; 6x2-305/45, 22x1-139/55, 4x1-47/50, 4-450TT	
	25	France	1914			
	26	Jean Bart	1913			
	4	27	Paris			1914
Bretagne	28	Bretagne	1915		25000t, 166.0x26.9x9.8m, 24b,4st(28,29)-18b,4st(30), 29000hp, 20kts, 1124-1133p; 250belt, 45deck, 400turrets, 300CT; 5x2-340/45, 22x1-139/55, 4x1-47/50, 4-450TT, 30mines	
	29	Lorraine	1916			
	3	30	Provence			1915
		1	Amiral Tréhouart	1896		6681t, 89.7x17.8x7.1m, 16b,2vte, 8500hp, 16.5-17kts, 343-362p; NS-

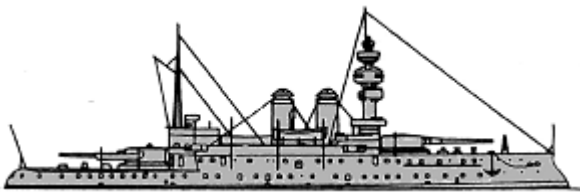
BC	Amiral Tréhouart	2				450belt, 110deck, 450turrets, 100CT; 2x1-305/45, 8x1-100/45, 4x1-47/40, 10x5-37/20(1), (8x5+4x1)-37/20(2), 2-450TT
			2	Bouvines		

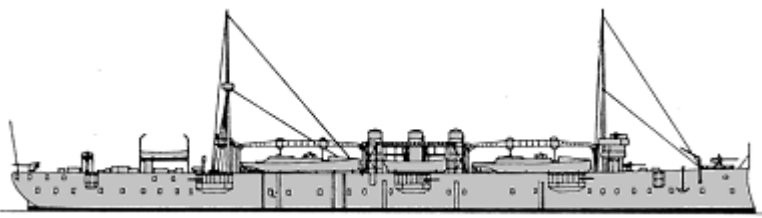

### AIRCRAFT CARRYING SHIPS

AV	Foudre	1	1	Foudre	1897		6089t, 118.7x17.2x7.1m, 24b,2vte, 11500hp, 19kts, 410p; Harvey- 120slopes, 60deck, 55shields, 120CT; 6x1-100/45, 2x1-90/24, 4x1-65/50, 8seaplanes
----	--------	---	---	--------	------	--	---

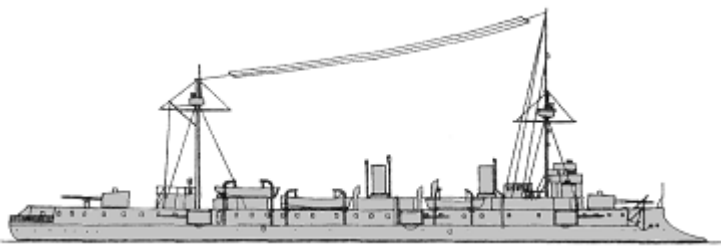
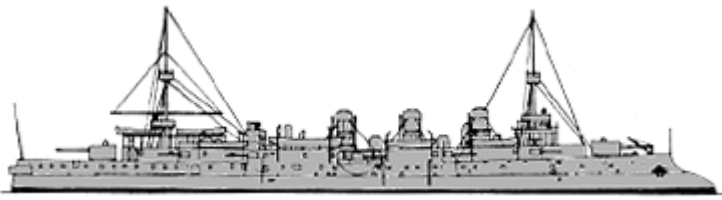
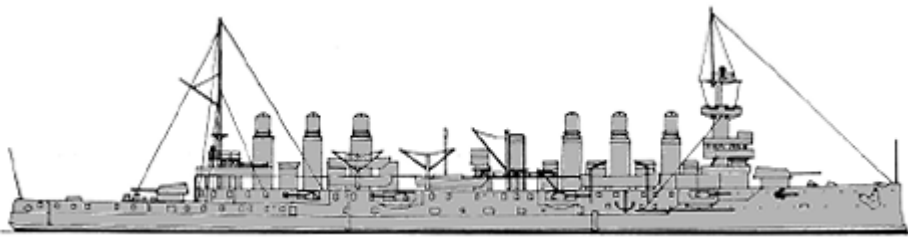
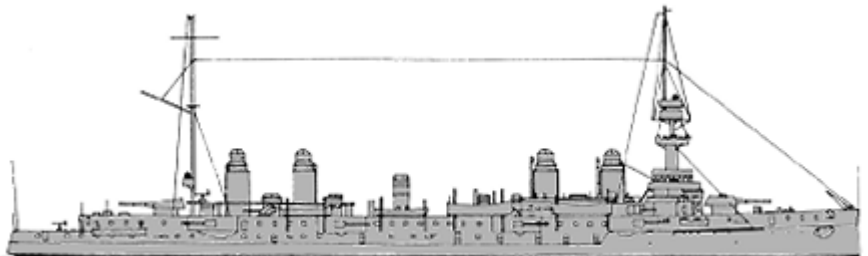
### CRUISERS

Amiral Charner	2	1	Bruix	1896		4681-4736t, 110.0x14.0x6.0m, 16b,3hte, 8000hp, 18.2kts, 393p; steel-90belt, 40deck, 110turrets, 110CT; 2x1-194/45, 6x1-139/45, 4x1-65/50, 4x1-47/40, 4-450TT
		2	Latouche-Tréville	1895		
Pothuau	1	3	Pothuau	1897		5374t, 113.0x15.3x6.5m, 18b,2vte, 10000hp, 19kts, 459p; NS- 60belt, 35deck, 170turrets, 230CT; 10x1-139/45, 2x1-75/63, 10x1-47/40, 8x1-37/20, 4-450TT
Jeanne d'Arc	1	4	Jeanne d'Arc	1902		11270t, 145.4x19.4x8.1m, 36b,3vte, 28000hp, 21kts, 651p; Harvey-150belt, 65deck, 160turrets, 150CT; 2x1-194/40, 14x1-139/45, 16x1-47/40, 2-450TT
Gueydon	2	5	Montcalm	1902		9177(5)-9548(6)t, 138.0x19.4x7.7m, 20b,3vte(5)-28b,3vte(6), 19600hp, 21kts, 566p; Harvey- 150belt, 55deck, 200turrets, 160CT; 2x1-194/40, 8x1-165/45, 4x1-100/45, 16x1-47/40, 4x1-37/20, 2-450TT
		6	Gueydon	1903		

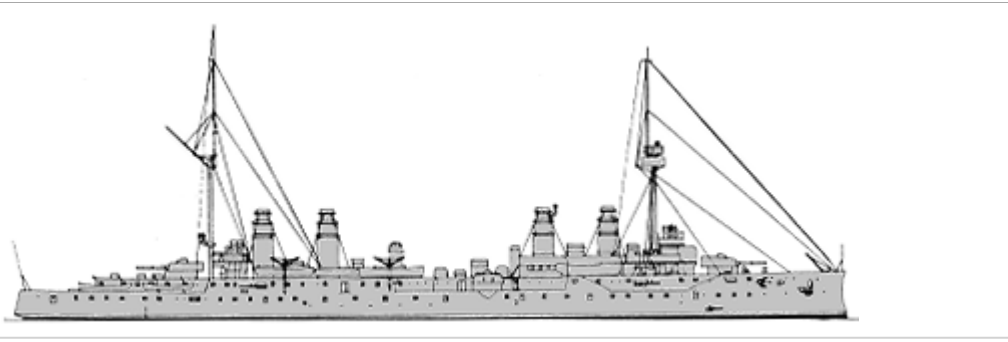
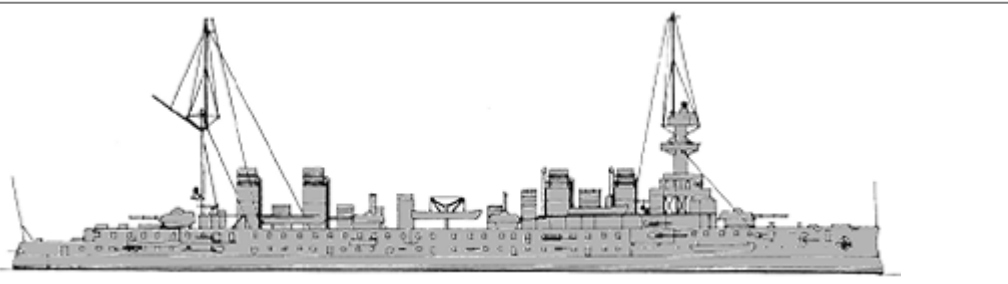
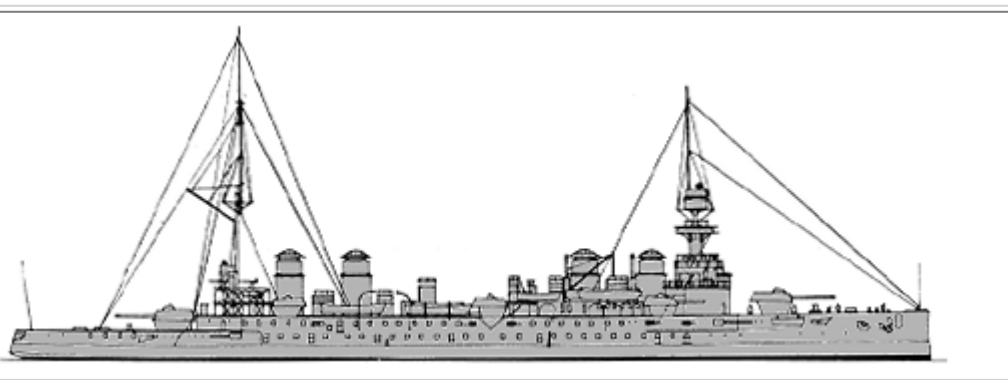
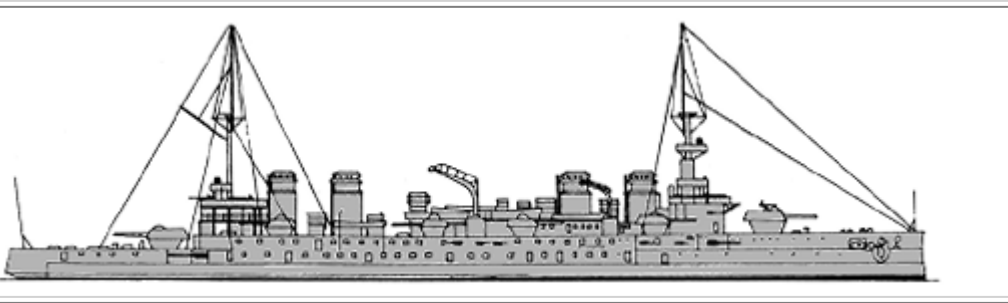
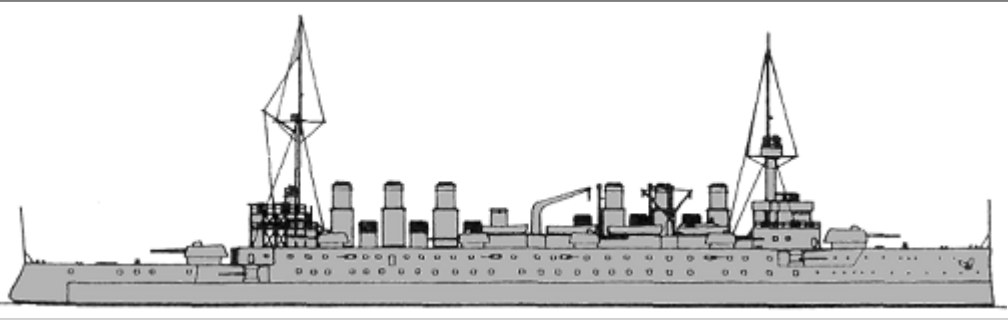



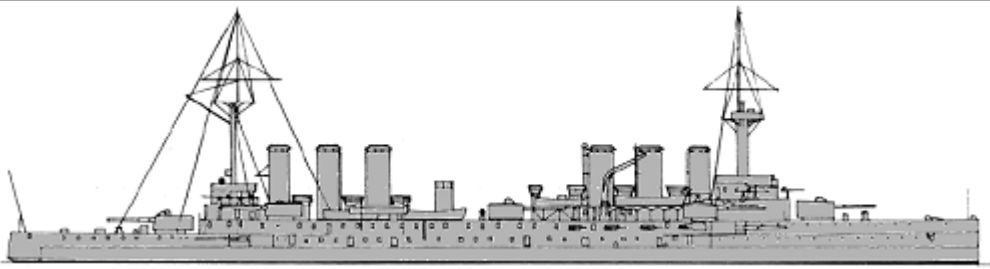
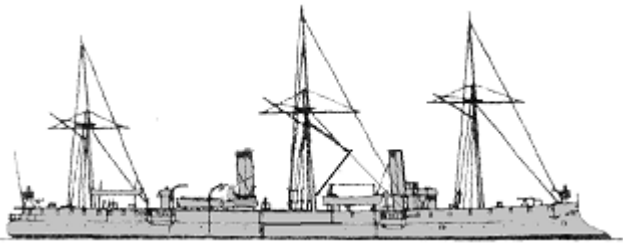
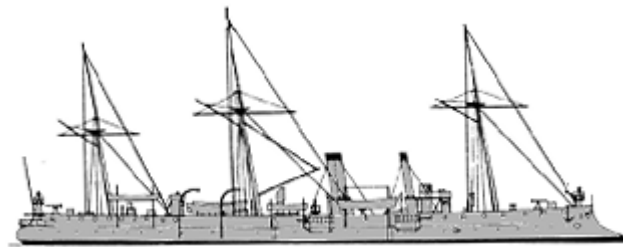
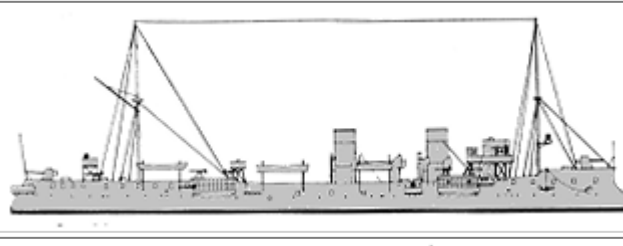
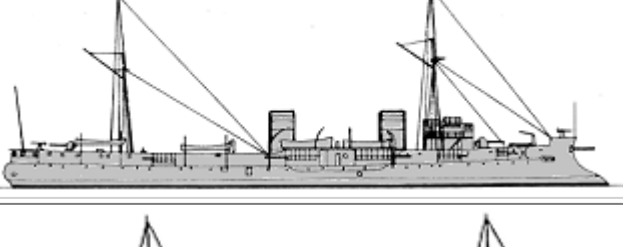
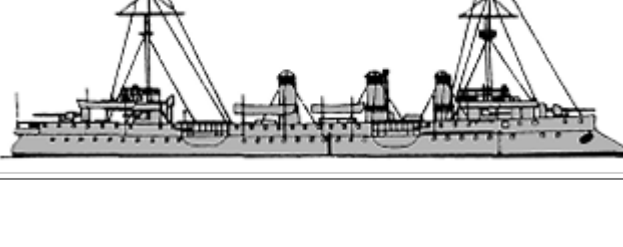

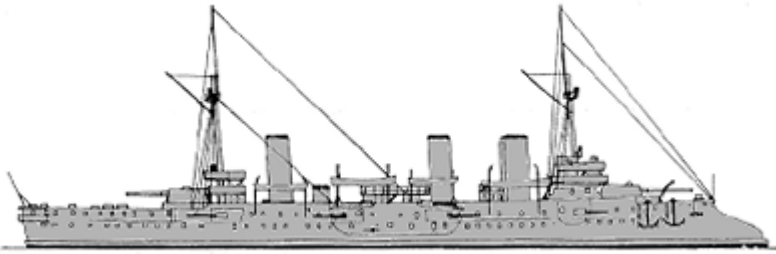
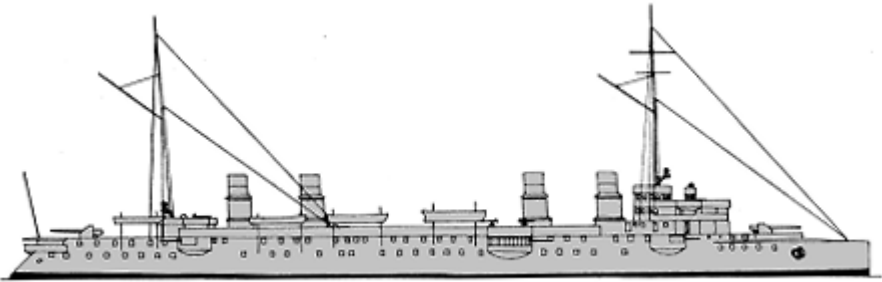
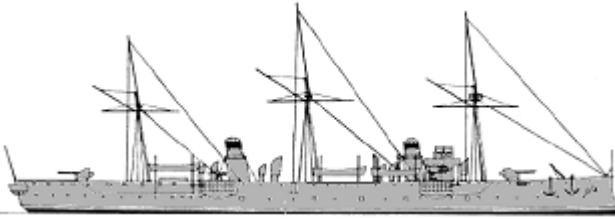
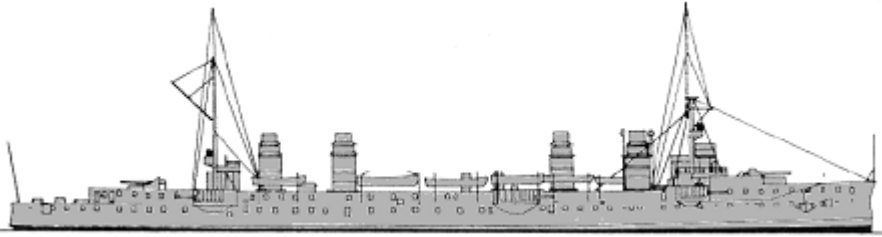

CA	Dupleix	1	7	Desaix	1904		7547t, 130.0x17.8x7.4m, 24b,3vte, 17500hp, 21kts, 531p; Harvey-100belt, 70deck, 160turrets, 80CT; 4x2-165/45, 2x1-47/50, 10x1-47/40, 4x1-37/20, 2-450TT
	Gloire	4	8	Amiral Aube	1904		9534(8)-10233(9)-10212(10)-9458(11)t, 139.8x20.2x7.5-7.7m, 24b,3vte(8,11)-28b,3vte(9,10), 21800hp, 21.5kts, 615p; Harvey-150belt, 80deck, 170turrets, 150CT; 2x1-194/40, 8x1-165/45, 6x1-100/45, 18x1-47/40, 2-450TT
			9	Condé	1904		
			10	Gloire	1904		
			11	Marseillaise	1903		
	Léon Gambetta	2	12	Jules Ferry	1905		12379(12)-13108(13)t, 146.5x21.4x8.1-8.4m, 28b,3vte(13)-20b,3vte(12), 28500hp, 22.5kts, 728p; 150belt, 35deck, 200turrets, 200CT; 2x2-194/40, (6x2+4x1)-165/45, 4x1-47/50, 18x1-47/40, 2x1-37/20, 2-450TT
			13	Victor Hugo	1907		
	Jules Michelet	1	14	Jules Michelet	1908		13105t, 146.5x21.4x8.4m, 28b,3vte, 30000hp, 22.5kts, 770p; 150belt, 35deck, 200turrets, 200CT; 2x2-194/50, 12x1-165/45, 16x1-47/50, 2-450TT
Ernest Renan	1	15	Ernest Renan	1909		13504t, 159.0x21.3x8.4m, 42b,3vte, 36000hp, 23kts, 824p; 150belt, 35deck, 200turrets, 200CT; 2x2-194/50, 12x1-165/45, 16x1-65/50, 8x1-47/50, 2x1-37/20, 2-450TT	
Edgar Quinet	2	16	Edgar Quinet	1911		13847(22)-13995(23)t, 158.9x21.5x8.4m, 40b,3vte(22)-42b,3vte(23), 36000hp, 23kts, 859-892p; 150belt, 35deck, 200turrets, 200CT;	
			Waldeck-				

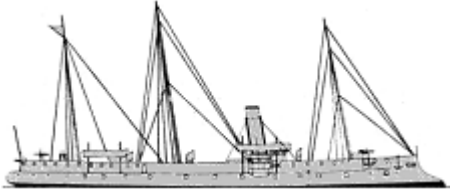
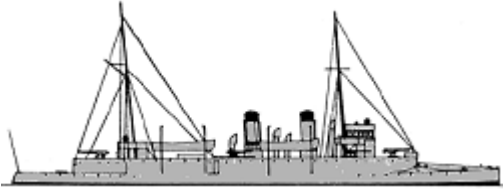

			17	Rousseau	1911		(2x2+10x1)-194/50, 20x1-65/50, 4x1-47/50, 2-450TT
	Forbin	1	1	Surcouf	1890		2012t, 95.0x9.0x5.2m, 6b,2hc, 5800hp, 20-20.5kts, 199p; steel- 40deck, 20CT; 4x1-139/30, 8x1-47/40, 4x5-37/20, 150mines
	Troude	1	2	Cosmao	1891		1923t, 95.0x9.0x5.2m, 5b,2hc, 5800hp, 20.5kts, 201p; steel- 40deck; 4x1-139/30, 10x1-47/40, 4x1-37/20, 150mines
	Linois	1	3	Lavoisier	1898		2318t, 100.6x10.6x5.4m, 16b,2vte, 6800hp, 20.5kts, 201p; steel- 40deck, 75shields, 125CT; 4x1-139/45, 2x1-100/45, 10x1-47/40, 2-450TT
	Descartes	1	4	Descartes	1896		3960t, 99.0x13.0x6.5m, 16b,2vte, 8500hp, 19.5kts, 383p; steel- 60slopes, 45deck, 50shields, 70CT; 4x1-165/45, 10x1-100/45, 8x1-47/40, 4x1-37/20, 2-450TT
CL	D'Assas	2	5	Cassard	1898		3890t, 99.0x13.7x6.3m, 20b,2vte, 10000hp, 20kts, 370-392p; 100slopes, 70deck, 50shields, 100CT; 6x1-165/45(5), 2x1-165/45(6), 4x1-100/45(5), 4x1-75/35(6), 10x1-47/40(5), 4x1-47/40(6), 9x1-37/20(5), 2-450TT
			6	Du Chayla	1898		
	D'Entrecasteaux	1	7	D'Entrecasteaux	1899		8142t, 120.0x17.8x7.5m, 5b,2vte, 14500hp, 19.2kts, 559p; Harvey- 100slopes, 55deck, 250turrets, 250CT; 2x1-240/40, 12x1-139/30, 12x1-47/40, 6x1-37/20, 6-450TT







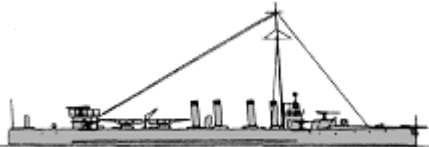
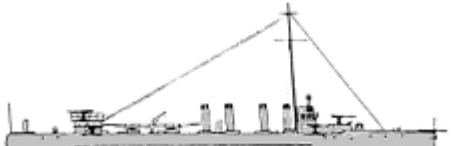
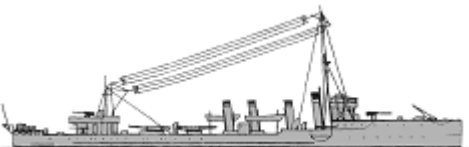
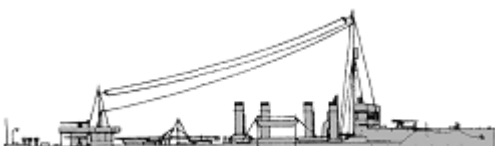

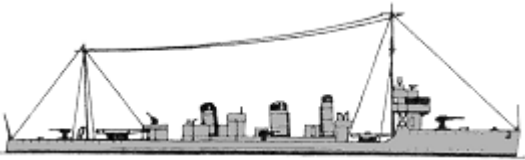

						
	Guichen	1 8	Guichen	1899		8151t, 139.0x17.0x7.5m, 36b,3vte, 25000hp, 23.5kts, 604p; Harvey-100slopes, 55deck, 60casemates, 160CT; 2x1-165/45, 6x1-139/45, 10x1-47/40, 5x1-37/20, 2-450TT
	D'Estrées	1 9	D'Estrées	1899		2428t, 95.0x12.0x5.4m, 8b,2vte, 8500hp, 20.5kts, 235p; steel- 43deck; 2x1-139/45, 4x1-100/45, 8x1-47/40, 2x1-37/20
	Jurien de la Gravière	1 10	Jurien de la Gravière	1903		5595t, 137.0x15.0x6.3m, 24b,3vte, 17400hp, 22.9kts, 463p; 65slopes, 80deck, 70shields, 100CT; 8x1-165/45, 10x1-47/40, 6x1-37/20, 2-450TT

TORPEDO SHIPS

PGT	Condor	1 1	Faucon	1887		1311t, 68.0ppx9.0x4.7m, 4b,2ic, 3000hp, 17kts, 137p; steel- 40deck; 5x1-100/26, 4x1-47/40, 6x5-37/20
	Dunois	2	Dunois	1898		889t, 78.0x8.4x3.9m, 8b,2vte, 7500hp, 21.7-22kts, 137p; steel- 25belt, 10deck, 50CT; 2x1-100/45(3), 6x1-65/50(2), 6x1-47/40
		3	La Hire	1899		
Durandal	2	1	Hallebarde	1899		296(1)-306(2)t, 57.6x6.3x3.2m, 2b,2vte, 4800hp, 26kts, 52p; 1x1-65/50, 6x1-47/40, 2x1-380TT
		2	Fauconneau	1900		

Framée	2	3	Pique	1901		314t, 58.1x6.3x3.0m, 4b,2vte, 4800-5200hp, 26kts, 48p; 1x1-65/50, 6x1-47/40, 2x1-380TT
		4	Epée	1901		
Pertuisane	4	5	Pertuisane	1902		344t, 57.6x6.3x3.2m, 2b,2vte, 4800hp, 26kts, 52p; 1x1-65/50, 6x1-47/40, 2x1-380TT
		6	Escopette	1903		
		7	Flamberge	1903		
		8	Rapière	1903		
Arquebuse	13	9	Sarbacane	1903		298t, 58.2x6.4x3.2m, 2b,2vte, 6300hp, 28kts, 60p; 1x1-65/50, 6x1-47/40, 2x1-380TT
		10	Arquebuse	1903		
		11	Arbalète	1903		
		12	Javeline	1903		
		13	Sagaie	1903		
		14	Epieu	1903		
		15	Harpon	1903		
		16	Francisque	1904		
		17	Sabre	1904		
		18	Mousqueton	1904		
		19	Arc	1904		
Claymore	13	20	Bélier	1904		350t, 58.5x6.5x3.0m, 2b,2vte, 6800hp, 28kts, 60p; 1x1-65/50, 6x1-47/50, 2x1-450TT
		21	Bombarde	1903		
		22	Styler	1907		
		23	Tromblon	1907		
		24	Pierrier	1908		
		25	Obusier	1907		
		26	Mortier	1908		
		27	Claymore	1906		
		28	Carquois	1908		
		29	Trident	1909		
		30	Fleuret	1908		
Branlebas	8	31	Coutelas	1908		339t, 57.9x6.6x2.4m, 2b,2vte, 6800hp, 27.5kts, 60p; 1x1-65/50, 6x1-47/50, 2x1-450TT
		32	Cognée	1908		
		33	Hache	1909		
		34	Massue	1909		
		35	Sabretache	1908		
		36	Oriflamme	1908		
		37	Fanion	1909		
		38	Sape	1908		
39	Gabion	1908				
40	Fanfare	1908				
41	Glaive	1910				

DD		42	Poignard	1910			
	Spahi	6	43	Spahi	1910		550t, 67.0x6.6x2.3-2.4m, 4b,2vte, 7500(44-48)-9000(43)hp, 28kts, 77-79p; 6x1-65/50, (1+2x1)-450TT
			44	Hussard	1911		
			45	Lansquenet	1910		
			46	Mameluk	1911		
			47	Enseigne Henry	1912		
			48	Aspirant Herber	1912		
	Chasseur	2	49	Janissaire	1911		520t, 67.0x6.5-6.7x3.1m, 4b,3st(50)-3b,3st(49), 7200hp, 28kts, 77-79p; 6x1-65/50, (1+2x1)-450TT(49), 2x1-450TT(50)
			50	Cavalier	1911		
	Voltigeur	2	51	Voltigeur	1910		590t, 65.5pp(64)-63.0pp(65)x6.8(64)-6.4(65)x3.1(64)-2.9(65)m, 4b,1vte+2st, 7500hp, 28kts, 76-77p; 6x1-65/50, (1+2x1)-450TT
			52	Tirailleur	1910		
	Bouclier	8	53	Bouclier	1911		760-820t, 72.3-78.3x7.6-8.0x2.9-3.3m, 4b,3st(53,54)-4b,2st(55-60), 13000hp, 30kts, 80-83p; 2x1-100/45, 1x1-75/35, 4x1-65/50, 2x2-450TT, 2dcr
			54	Casque	1911		
			55	Cimeterre	1912		
			56	Capitaine Mehl	1912		
			57	Commandant Bory	1913		
			58	Commandant Rivière	1913		
			59	Dehorter	1913		
			60	Francis Garnier	1913		
	Bisson	5	61	Bisson	1913		855t, 78.1ppx8.6x3.1m, 4b,2st, 15000hp, 30kts, 80-83p; 2x1-100/45, 1x1-75/35, 4x1-65/50, 2x2-450TT, 2dcr
			62	Commandant Lucas	1914		
			63	Protet	1914		
			64	Mangini	1914		
			65	Magon	1914		
	Aventurier	4	66	Opiniâtre	1914		1250t, 88.5x8.8x3.1m, 4b,2st(66,68)-5b,2st(67,69), 18000(66,68)-12000(67,69)hp, 32(66,68)-22(67,69)kts, 140p; 4x1-100/45, 1x1-47/50, 4x1-450TT
67			Aventurier	1914			
68			Téméraire	1914			
69			Intrépide	1914			
Enseigne Roux	2	70	Enseigne Roux	1916		1075t, 82.6x8.6x3.0m, 4b,2st, 17000hp, 30kts, 76-81p; 2x1-100/45, 1x1-75/35, 4x1-65/50, 2x2-450TT, 2dcr	
		71	Mécanicien Principal Lestin	1916			
		72	Algérien	1917			
		73	Annamite	1917			
		74	Arabe	1917			
		75	Bambara	1917			

	Arabe	12	76	Hova	1917		750t, 83.0x7.3x2.4m, 4b,3vte, 10000hp, 29kts, 86p; 1x1-120/40, 4x1-76/40, 2x2-450TT									
			77	Kabyle	1917											
			78	Marocain	1917											
			79	Sakalave	1917											
			80	Sénégalais	1917											
			81	Somali	1917											
			82	Tonkinois	1917											
			83	Touareg	1917											
TB	Coureur	1	1	Grondeur	1892		131t, 45.1x4.4x1.4m, 2b,2vte, 1750hp, 23.5kts; 2x1-47/40, 2-350TT									
								Agile	1	2	Orage	1892		119t, 43.6x4.6x1.1m, 2b,1vte, 1100hp, 27kts; 3x5-37/20, (1+1x1)-380TT		
	Averne	1	3	Averne	1894		131t, 43.9x4.6x1.3m, 2b,2vte, 1750hp, 23.5kts; 2x1-47/40, (1+1x1)-380TT									
								Filibustier	1	4	Ariel	1895		123t, 42.0x4.5x1.7m, 2b,2vte, 2000hp, 23.5kts; 2x1-47/40, (1+1x1)-380TT		
	Forban	1	5	Forban	1896		150t, 44.0x4.6x1.4m, 2b,2vte, 3260hp, 29kts, 29p; 2x1-37/20, 2x1-380TT									
								Cyclone	5	6	Cyclone	1899		150(6)-165(7-10)t, 46.4(6)-46.6(7-10)x4.7(6)-4.8(7-10)x1.5m, 2b,2vte, 4200(6)-3800(7-10)hp, 29kts; 2x1-47/40, 1x2-380TT		
	7	Bourrasque	1902													
	8	Rafale	1902													
	9	Borée	1901													
	Mistral	6		10	Tramontane	1902		183t, 45.0x5.2x1.6m, 2b,2vte, 4200hp, 26kts, 30p; 24belt, 9deck; 2x1-47/40, 2x1-380TT								
				11	Mistral	1901										
				12	Siroco	1901										
				13	Simoun	1901										
				14	Typhon	1903										
				15	Trombe	1902										
	No130	1	1	No135	1890		52t, 34.0ppx3.5x0.9m, 1b,1vte, 720hp, 20kts, 18p; 2x1-37/20, 2x1-380TT									
No145								1	2	No158	1892		78t, 35.9ppx3.9x1.2m, 1b,1vte, 1000hp, 21kts, 22-23p; 2x5-37/20, (1+1x1)-380TT			
														No201	29	3-31
32								No295	1906							
33								No296	1906							
										34	No297	1906				

TB2

No295

73



35	No299	1906
36	No301	1906
37	No302	1906
38	No303	1905
39	No306	1905
40	No307	1905
41	No308	1906
42	No309	1906
43	No310	1906
44	No311	1906
45	No312	1905
46	No313	1905
47	No314	1906
48	No315	1905
49	No316	1906
50	No318	1907
51	No320	1907
52	No321	1907
53	No322	1906
54	No323	1906
55	No324	1906
56	No326	1907
57	No327	1907
58	No328	1907
59	No329	1907
60	No330	1908
61	No332	1907
62	No334	1907
63	No335	1907
64	No336	1907
65	No337	1908
66	No338	1906
67	No339	1906
68	No340	1907
69	No341	1906
70	No342	1906
71	No343	1906
72	No344	1906
73	No345	1906
74	No346	1906











103-105t, 38.0x4.4x1.9m, 2b,1vte, 1800-2000hp, 26kts, 23p; 2x5-37/20, (1+1x2)-450TT

75	No349	1906
76	No350	1906
77	No351	1906
78	No352	1907
79	No353	1907
80	No355	1906
81	No356	1907
82	No357	1907
83	No359	1906
84	No360	1906
85	No361	1906
86	No362	1906
87	No363	1906
88	No364	1906
89	No365	1908
90	No366	1909
91	No367	1907
92	No368	1907
93	No369	1908

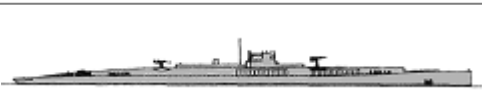
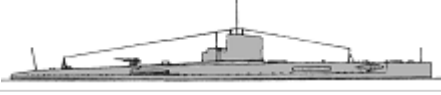
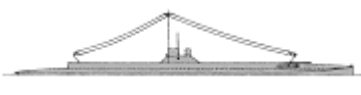
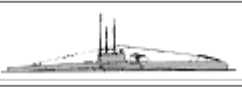
## SUBMARINES

Brumaire	11	1	Brumaire	1913		397/551t, 52.1x5.1x3.1m, 2d/em, 840/660hp, 13/8.8kts, 29p, 40m; 1x1-75/35(some), 1-450TT, 6-450TC
		2	Frimaire	1913		
		3	Nivôse	1913		
		4	Euler	1914		
		5	Franklin	1914		
		6	Faraday	1913		
		7	Volta	1913		
		8	Newton	1914		
		9	Montgolfier	1914		
		10	Arago	1914		
		11	Le Verrier	1914		
Charles Brun	1	12	Charles Brun	1913		356/450t, 44.0x4.0x3.3m, 4b,2vte, 1300hp, 13.5/7.2kts, 24p, 40m; 2-450TT, 4-450TC
Gustave Zédé	2	13	Gustave Zédé	1914		849/1098(13)-820/1047(14)t, 74.0x6.0x3.7m, 2b,2vte/em(13)-2d/em(14), 3500/1640(13)-2400/1640(14)hp, 17.6/11.4(13)-17.3/10.5(14)kts, 47p, 50m; 1x1-75/34, 1x1-47/50, 2-450TT, 6-450TC
		14	Néréide	1916		
		15	Amphitrite	1915		414/609(15-19)-440/610(20,21)t, 53.9x5.4x3.3m, 2d/em, 800/700hp, 12-13/9.5kts, 29p, 40m; 1x1-75/35, 8-
		16	Artémis	1915		
		17	Aréthuse	1916		

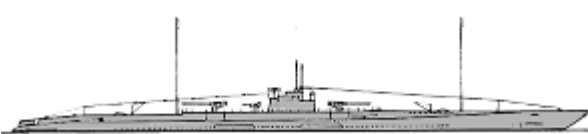



SS	Amphitrite	7	18	Atalante	1915		450TC, 20mines(20,21)	
			19	Andromaque	1916			
			20	Astrée	1918			
			21	Amarante	1918			
	Clorinde	2	22	Clorinde	1916		413/567t, 53.9x5.1x3.4m, 2d/em, 800/700hp, 13/9kts, 29p, 40m; 1x1-75/35, 8-450TC	
				23	Cornélie			1917
	Bellone	3	24	Bellone	1916		523/788t, 60.6x5.4x3.5m, 2d/em, 1640/800hp, 14.7/9.5kts, 38p, 50m; 1x1-75/35, 8-450TC	
				25	Hermione			1917
				26	Gorgone			1916
	Dupuy de Lôme	2	27	Dupuy de Lôme	1916		833/1287t, 75.0x6.4x3.6m, 2b,2vte/em, 3500/1640hp, 17/11kts, 43p, 50m; 1x1-75/35, 1x1-47/50, 2-450TT, 6-450TC	
				28	Sané			1916
	Diane	1	29	Daphné	1916		633/891t, 68.0x5.5x3.7m, 2d/em, 1800/1400hp, 17/11.5kts, 43p, 50m; 1x1-75/35, 2-450TT, 8-450TC	
Armide	3	30	Armide	1916		457/670t, 56.2x5.2x3.0m, 2d/em, 2200/900hp, 17.5/11kts, 31p, 50m; 1x1-75/35(32), 1x1-47/50(30,31), 4-450TT, 2-450TC(30)		
			31	Antigone			1917	
			32	Amazone			1917	
Roland Morillot	1	33	Roland Morillot	1916		265/291t, 36.1x4.4x3.7m, 1d/em, 270/280hp, 8.9/5.7kts, 23p, 50m; 1x1-50/37, 2-500TT		
Lagrange	2	34	Lagrange	1918		920/1318t, 75.2x6.3x3.6m, 2d/em, 2600/1640hp, 16.5/11kts, 47p, 50m; 2x1-75/35, 2-450TT, 6-450TC		
			35	Romazotti			1918	
Victor Réveille	1	36	Victor Réveille	1916		755/832t, 56.8x5.9x4.9m, 2d/em, 900/800hp, 9.9/7.8kts, 32p, 50m; 1x1-105/42, 2-500TT, 38mines		
Jean Autric	2	37	Jean Autric	1917		798/1000t, 71.6x6.3x3.9m, 2d/em, 2400/1200hp, 16.4/8.4kts, 36p, 50m; 1x1-105/42, 1x1-88/27, 6-500TT		
			38	Léon Mignot			1917	
René Audry	1	39	René Audry	1918		1164/1512t, 81.5x7.4x4.2m, 2d/em, 2400/1200hp, 14.7/7kts, 40p, 75m; 1x1-149/42, 4-500TT, 72mines		
Halbronn	1	40	Halbronn	1918		1930/2483t, 92.0x9.1x5.3m, 2d+1dg/em, 3500+450/1780hp, 62p, 75m; 2x1-149/42, 6-500TT		
Pierre Marrast	2	41	Pierre Marrast	1918		821/1002t, 71.6x6.3x3.9m, 2d/em, 2400/1230hp, 16.2/8.2kts, 39p, 50m; 1x1-105/42, 6-500TT		
			42	Jean Roulier			1919	
Trinité-Schillemans	2	43	Trinité-Schillemans	1918		510/640t, 55.5x5.8x3.7m, 2d/em, 1100/788hp, 13/7.4kts, 34p, 75m; 1x1-105/42, 5-500TT		
			44	Carrisan			1918	
Jean Corre	1	45	Jean Corre	1919		539/656t, 55.5x5.8x3.9m, 2d/em, 1060/788hp, 13.5/7.5kts, 34p, 75m; 1x1-105/42, 5-500TT		

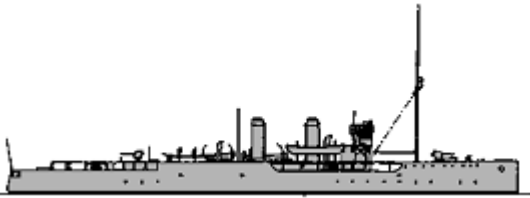
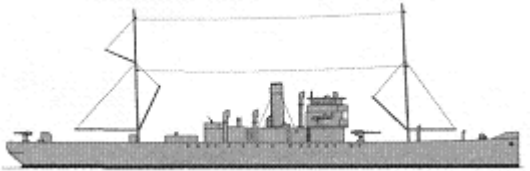
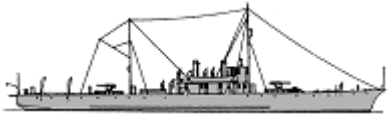

## ESCORTS

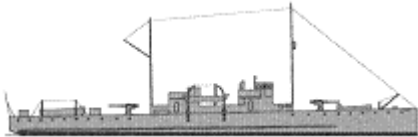
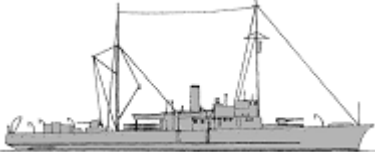
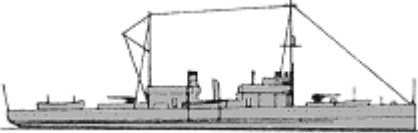
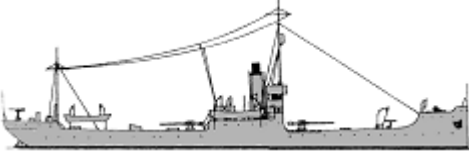
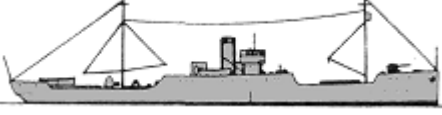
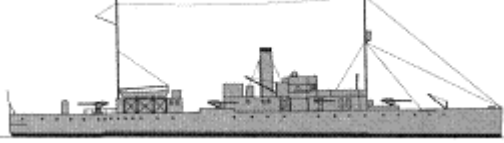
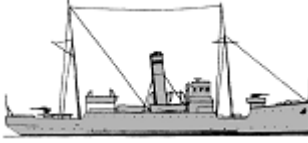
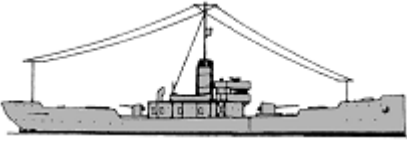

SL	Aldébaran	7	1	Aldébaran	1916		1470t, 81.5x10.5x4.2m, 2b,1vte, 2800hp, 17.5kts, 103p; 2x1-139/45, 2x1-75/35, 2DCT, 1DCR
			2	Algol	1916		
			3	Altair	1916		
			4	Antarès	1916		
			5	Bellatrix	1916		
			6	Cassiopée	1917		
			7	Régulus	1917		
		Andromédé	1	8	Ville d'Ys	1917	
Ardent	23	1	Agile	1916		400-410t, 60.2x7.2x2.9m, 2b,1vte(1,3,9,10,12,16,20,21)-2vte(2,4-8,11,13-15,17-19,22,23), 1200-2200hp, 14-17kts, 55-60p; 2x1-145/45(3,16,20), 2x1-100/45(1,2,4-15,17-19,21-23), 2DCT, MS	
		2	Alerte	1916			
		3	Ardent	1916			
		4	Belliqueuse	1916			
		5	Boudeuse	1916			
		6	Capricieuse	1916			
		7	Courageuse	1916			
		8	Curieuse	1916			
		9	Emporté	1916			
		10	Espiègle	1917			
		11	Gracieuse	1916			
		12	Inconstant	1916			
		13	Malicieuse	1916			
		14	Moqueuse	1916			
		15	Railleuse	1916			
		16	Sans Souci	1916			
		17	Audacieuse	1917			
		18	Batailleuse	1917			
		19	Dédaigneuse	1917			
		20	Étourdi	1917			
		21	Éveillé	1917			
		22	Impétueuse	1917			
		23	Tapageuse	1917			
			24	Bouffonne	1917		

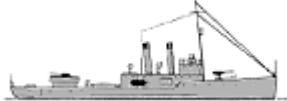
FS	Friponne	8	25	Chiffonne	1918		315t, 66.4x7.0x2.8m, 2d, 900hp, 14.5kts, 54p; 2x1-100/45, 2DCT
			26	Diligente	1918		
			27	Engageante	1918		
			28	Impatiente	1917		
			29	Friponne	1917		
			30	Mignonne	1918		
			31	Surveillante	1918		
			Marne	6	32		
33	Oise	1917					
34	Somme	1917					
35	Yser	1917					
36	Aisne	1918					
37	Meuse	1918					
Luronne	1	38	Luronne	1917		400t, 60.2x7.2x2.9m, 2d, 630hp, 13.7kts, 54p; 2x1-100/45, 2DCT	
Conquérante	2	39	Conquérante	1917		457t, 66.4x7.9x2.8m, 2d, 1800hp, 17kts, 54p; 2x1-100/45, 2DCT	
		40	Valliante	1917			
Amiens	3	41	Arras	1918		850t, 74.9x8.7x3.2m, 2b,2gt, 5000hp, 20kts, 103p; 2x1-139/55, 1x1-75/35, 2DCT	
		42	Dunkerque	1918			
		43	Reims	1918			
Ailette	2	44	Ailette	1918		492t, 70.0x8.3x3.1m, 2b,2gt, 4000hp, 20kts, 107p; 4x1-100/45, 2x1-65/50	
		45	Escaut	1918			
Scarpe	3	46	Ancre	1918		604t, 76.2x8.7x3.3m, 2b,2gt, 5000hp, 20kts, 107p; 4x1-100/45, 1x1-65/50, 2DCT	
		47	Scarpe	1918			
		48	Suippe	1918			
Flamant	1	49	Quentin Roosevelt	1918		585t, 50.0x8.4x5.8m, 2b,1vte, 1200hp, 14.5kts, 53p; 1x1-75/35, 1x1-47/50	
Dubordieu	3	50	Du Chaffault	1918		453t, 64.9x8.2x3.1m, 2b,2gt, 2000hp, 16.5kts, 74p; 1x1-139/45, 1x1-100/45, 2DCT	
		51	Dubordieu	1918			
		52	Dumont D`Urville	1919			
C1	16	1 - 16	C11, 25, 26, 31, 51, 56, 58, 67, 72, 74, 81, 91, 92, 95, 96, 98	1917 - 1918		85t, 33.5x4.7x2.3m, 3pe, 660hp, 16.5kts, 27p; 1x1-75/35, 1DCT	

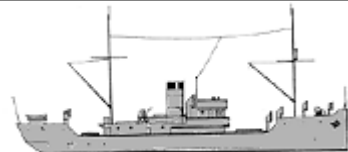

SC	C101	9	17	Ch102	1919	 	150t, 43.4x5.2x2.4m, 2b,2vte, 1300hp, 16.5kts, 31p; 1x1-75/35, 1DCT
			18	Ch103	1919		
			19	Ch104	1919		
			20	Ch105	1919		
			21	Ch106	1919		
			22	Ch107	1919		
			23	Ch108	1919		
			24	Ch109	1919		
			25	Ch110	1919		
			Loup	3	1		
2	Marcassin	1917					
3	Sanglier	1917					
Gardon	1	4	Cinquet	1918	No picture	665t, 1d, 10kts; 1x1-100/45, 1x1-47/50, 2dcr	
Hippopotame	4	5	Mammoth	1917	No picture	970t, 2b,1vte, 1800hp, 12kts; 2x1-75/35	
		6	Hippopotame	1918			
		7	Rhinocéros	1918			
		8	Mastodonte	1919			
Aurochs	4	9	Zébu	1917	No picture	290t, 1b,1vte, 650hp, 10kts; 1x1-90/24, 1x1-47/40	
		10	Aurochs	1918			
		11	Renne	1918			
		12	Élan	1919			
Clameur	6	13	Fracas	1917	No picture	370t, 2b,1vte, 720hp, 12kts; 1x1-90/24	
		14	Clameur	1918			
		15	Tapage	1918			
		16	Tintamarre	1918			
		17	Tumulte	1918			
		18	Vacarme	1918			
Athlete	3	19	Athlete	1917	No picture	585t, 1b,2vte, 500hp, 12kts; 2x1-120/40	
		20	Gladiateur V	1918			
		21	Lutteur	1919			
Navarin	10	22	Bautzen	1918	No picture	640t, 1vte, 500hp, 11kts, 31p; 1x1-100/45	
		23	Leoben	1918			
		24	Lutzen	1918			
		25	Malakoff	1918			
		26	Mantoue	1918			
		27	Navarin	1918			
		28	Palestro	1918			
		29	Sebastopol	1918			
		30	Seneff	1918			

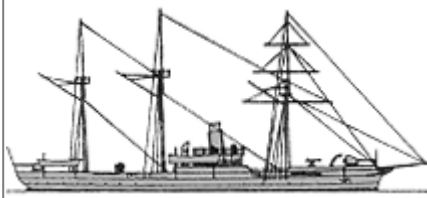
PC	Mauviette	6	31	St-Georges	1918		460t, 43.5x7.3x4.2m, 1b,1vte, 10kts; 1x1-90/24, 1x1-47/40, MS
		32	Ortolan	1918			
		33	Passereau II	1918			
		34	Perruche II	1918			
		35	Pie II	1918			
		36	Roitelet II	1918			
		37	Rossignol II	1918			
	Pluvier	12	38	Colombe	1918	No picture	(680-780)t, 1vte, 750hp, 11kts
			39	Faisan	1918		
			40	Gelinotte	1918		
			41	Heron II	1918		
			42	Paon	1918		
			43	Pigeon	1918		
			44	Pingouin II	1918		
			45	Pintade	1918		
			46	Pluvier	1918		
			47	Ramier	1918		
			48	Tourterelle	1918		
			49	Vanneau II	1918		
Crabe	9	50	Cèdre	1918	No picture	(360-370)t, 1b,1vte, 400hp, (9-10)kts; 1x1-90/24	
		51	Chêne	1918			
		52	Crabe	1918			
		53	Erable	1918			
		54	Orme	1918			
		55	Tourteau	1918			
		56	Frêne	1919			
		57	Hêtre	1919			
		58	Peuplier	1919			
Bouvines	8	59	Austerlitz	1919	No picture	684t, 45.0x7.8xm, 1vte, 500hp, 9.5kts; 2x1-100/45	
		60	Bouvines	1919			
		61	Fleurus	1919			
		62	Jemmapes	1919			
		63	Lodi	1919			
		64	Magenta	1919			
		65	Marengo	1919			
		66	Valmy	1919			
Jacques Coeur	1	67	Jacques Coeur	1919		700t, 51.3x7.9x4.3m, 2b,1vte, 1100hp, 12kts; 2x1-100/45	



## OTHER FIGHTING SHIPS

PG	Surprise	1	1	Décidée	1898		617-637t, 56.0-56.3ppx7.9-8.0x3.7m, 2b,1hte, 900hp, 13kts, 99p; 2x1-100/45, 4x1-65/50, 4x1-37/20
PR	Vigilante	3	1	Argus	1900	No picture	123t, 44.2x7.3x0.6m, 2b,2vte, 500hp, 13kts, 53p; 2x1-90/24, 4x1-37/20
			2	Vigilante	1900		
			3	Pei-Ho	1901		
PR	Doudart de la Grée	1	4	Doudart de la Grée	1909		183t, 54.4x6.7x1.0m, 2b,2vte, 900hp, 14kts, 66p; 1x1-75/35, 2x1-37/20
				A	4	5	Aisne
A	6	Marne	1915				
	7	Oise	1915				
	8	Somme	1915				

## COASTAL FORCES

PS	V1	37	1-37	V1-20, 22, 24-36, 38-40	1916-1917		40t, 24.0x3.8x1.1m, 2pe, 440hp, 20kts, 8p; 1x1-75/35, 1dct
	V41	12	38-49	V41-53	1917	No picture	40t, 25.0x3.7x1.0m, 2pe, 20kts; 1x1-75/35, 1dct
	V54	8	50-57	V54-61	1917	No picture	40-41t, 26.5x4.0x1.3m, 2pe, 360hp, 14.5kts
	V62	12	58-69	V62-73	1918		41t, 23.4x3.8x1.5m, 2pe, 440hp, 19kts, 16p; 1x1-75/35, 1dct

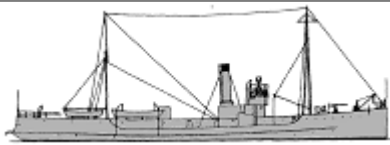
## MINE WARFARE SHIPS

ML	Pluton	2	1	Pluton	1913		660t, 59.0x8.3x3.3m, 1vte, 3000hp, 20kts, 90p; 1x1-75/35, 120mines
			2	Cerbère	1912		
MS	Herse	3	1	Charrue	1914	No picture	255t, 34.0x6.8x2.4m, 1vte, 600hp, 12kts; 2x1-47/40, sweeps
			2	Pioche	1914		
			3	Rateau	1914		
MS	Granit	5	4	Granit	1918		360t, 57.6x7.9x2.3m, 1b,1vte, 600hp, 12.5kts, 63p; 2x1-65/50, sweeps
			5	Gres	1918		
			6	Marble	1918		
			7	Mica	1918		
			8	Porphyre	1918		
			9	Albâtre	1919		

	Albâtre	7	10	Basalte	1919		380t, 57.6x7.9x2.3m, 1b,1vte, 500hp, 10.5kts, 63p; 1x1-65/50, sweeps
			11	Gypse	1919		
			12	Meulière	1919		
			13	Pyrite	1919		
			14	Quartz	1919		
			15	Silex	1919		
TL	Camelia	10	1	Camelia	1918	No picture	124t, 1b,1vte, 170hp, 8kts; 1x1-75/35, sweeps
			2	Datura	1918		
			3	Francoa	1918		
			4	Fresia	1918		
			5	Godetia	1918		
			6	Ipeca	1918		
			7	Magnolia	1918		
			8	Paulownia	1918		
			9	Reseda	1918		
			10	Zinnia	1918		
TL	Ajonc	10	11	Ajonc	1918	No picture	112t. 1pe, 220hp, 9.5kts; 1x1-75/35, sweeps
			12	Aster	1918		
			13	Chardon	1918		
			14	Genet	1918		
			15	Jasmin	1918		
			16	Lilas	1919		
			17	Lupin	1919		
			18	Mugnet	1919		
			19	Myosotis	1919		
			20	Nenuphar	1919		
TL	Fanfaron	10	21	Fanfaron	1918	No picture	154t, 1b,1vte, 300hp, 9kts; 1x1-75/35 or 1x1-90/24, sweeps
			22	Fantasque	1918		
			23	Farouche	1918		
			24	Favori	1918		
			25	Flambant	1918		
			26	Fougueux	1919		
			27	Forrageur	1919		
			28	Frondeur	1919		
			29	Fulgurant	1919		
			30	Furieux	1919		
	Amandier	2	31, 32	Amandier, Bananier	1918	No picture	78t, 1pe, 160hp, 9kts; 1x1-47/40, sweeps
	Campanule	12	33- 44	Campanule, Clematite, Jacinthe, Jonquille, Lavende, Marjolaine, Paquerette, Perce-Neige, Renoncule, Sauge, Tulipe, Vilette	1918- 1919	No picture	80t, 1pe, 325hp, 13kts; sweeps
			45	Bombardier	1918		

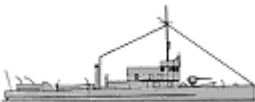
Briscard	16	46	Briscard	1918		440t, 41.0x7.3x3.2m, 1b,1vte(45-51,53-57,59,60)-1pe(52,58), 420-500hp, 11-11.5kts, 41p; 1x1-75/35, sweeps
		47	Canonier	1919		
		48	Chevronne	1919		
		49	Franc-Tireur	1919		
		50	Fusilier	1919		
		51	Grognard	1919		
		52	Mathurin	1919		
		53	Mitrailleur	1919		
		54	Pionnier	1919		
		55	Poilu	1919		
		56	Rengage	1919		
		57	Sapeur	1919		
		58	Troupier	1919		
		59	Veteran	1919		
		60	Volontaire	1919		
		ATL	-	1		



© Ivan Gogin, 2014



[home](#)[World navies yesterday](#)[1920](#)

# Germany 01 January 1920

## BATTLESHIPS

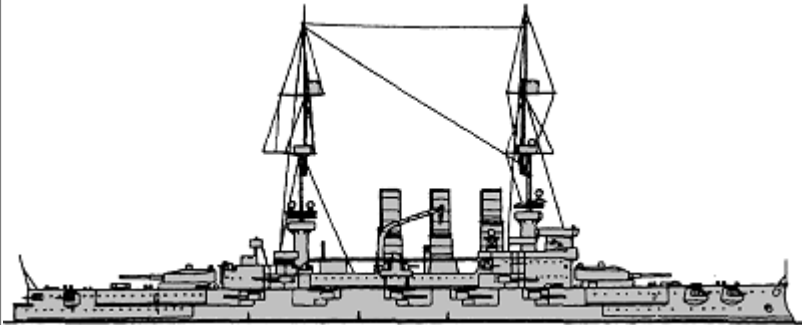



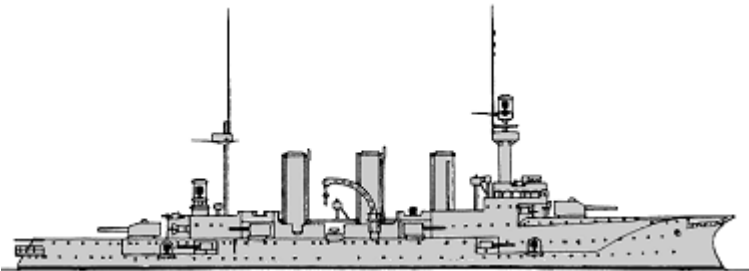
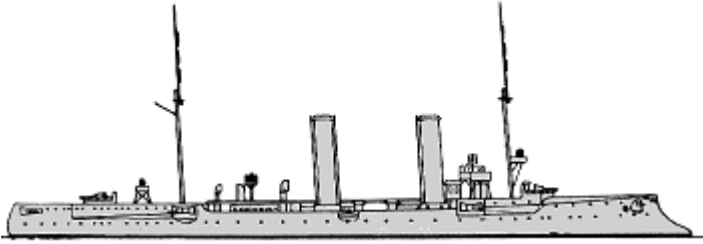
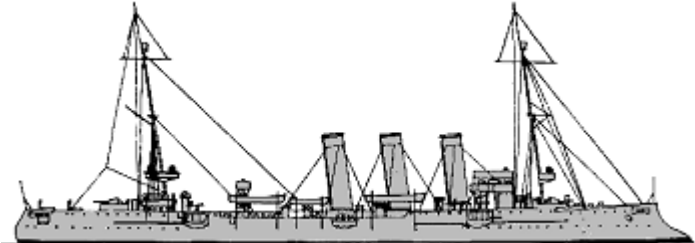

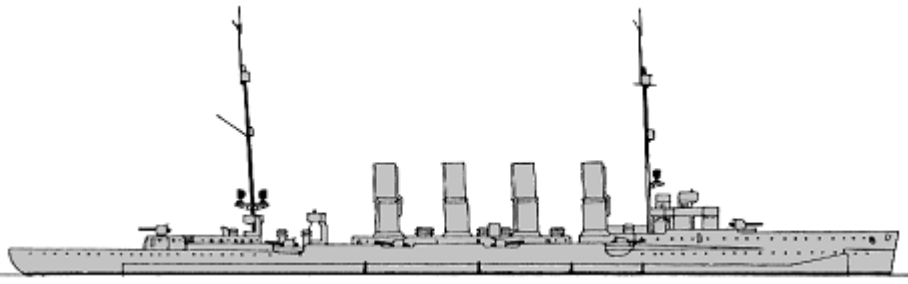
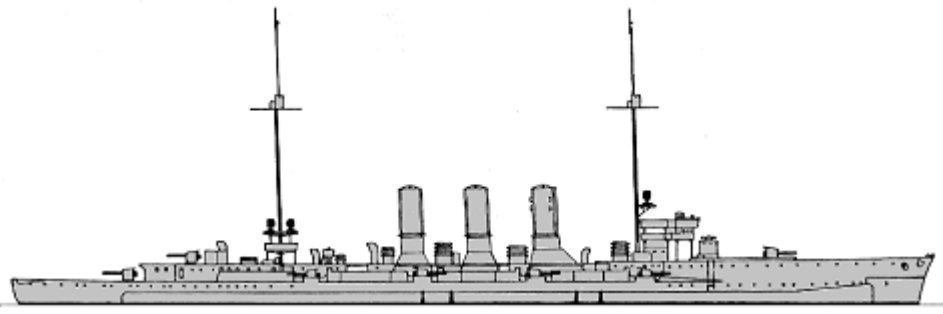
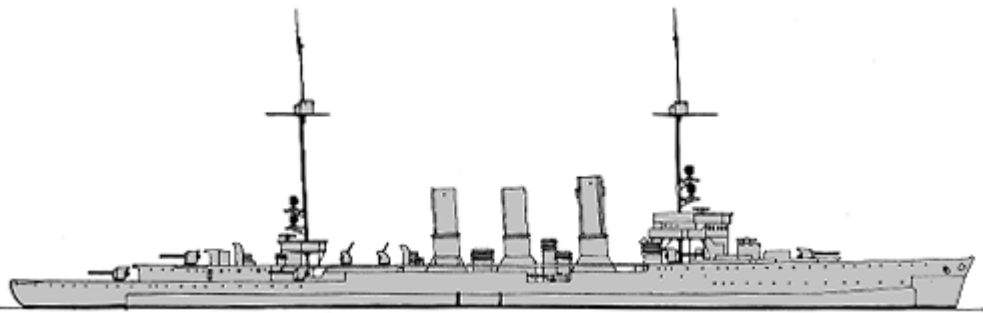
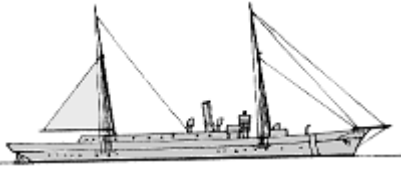
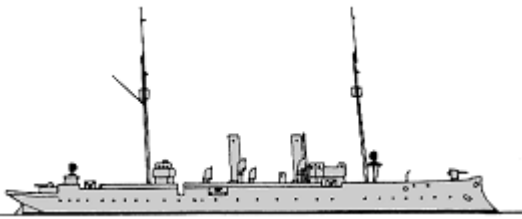
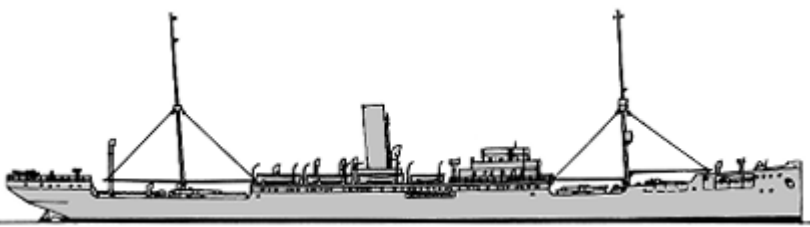

		1	Hannover	1907		<p>13994t, 127.6x22.2x8.3m, 12b,3vte, 20540hp, 19.1kts, 743p; 240belt, 40deck, 280turrets, 300CT; 2x2-283/37, 14x1-173/37, 20x1-88/32, 6-450TT</p>
BB	Deutschland	2	Schlesien	1908		

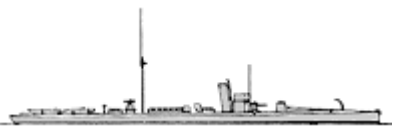

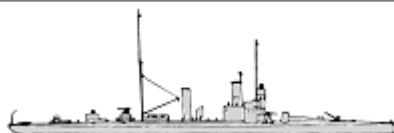
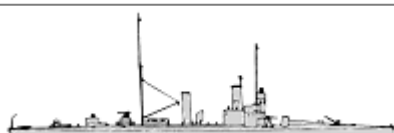

## CRUISERS

	Victoria Louise	1	1	Freya	1898		<p>6491t, 110.6x17.4x6.8m, 8b,3vte, 10000hp, 19.5kts, 477p; 100slopes, 40deck, 100turrets, 150CT; 1x1-149/37, 4x1-105/42, 3x1-88/32, 11x1-88/27</p>
	Gazelle	9	2	Nymphe	1900		<p>3082(2-4)-3180(5)t, 105.0(5)-105.1(2-4)x12.2(2-4)-12.4(5)x5.5(5)-5.4(2-4)m, 10b,2vte(2)-9b,2vte(3-5), 9020(2-4)-8580(5)hp, 21.8(2-4)-21.5(5)kts, 249(2-4)-259(5)p; 50slopes, 25deck, 50shields, 80CT; 9x1-105/42(3), 10x1-105/37(2,4,5), 2x1-500TT(5), 2-450TT(2-4), 200mines(5)</p>
			3	Thetis	1901		
			4	Amazone	1901		
			5	Arcona	1903		
	Bremen	1	6	Berlin	1905		<p>3816t, 111.1x13.3x5.6m, 10b,2vte, 11750hp, 23kts, 288p; 80slopes, 35deck, 50shields, 100CT; 10x1-105/37, 2-450TT, 80mines</p>



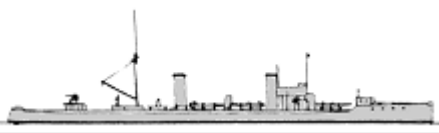
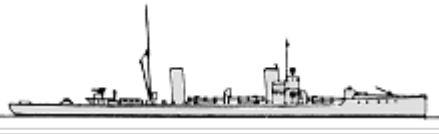
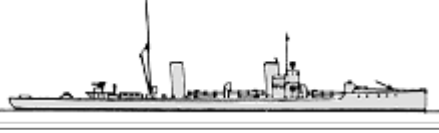

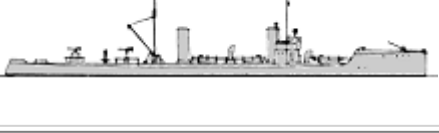
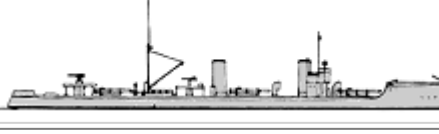
CL	Magdeburg 2	7	Strassburg	1912		5281(7)-5587(8)t, 138.7x13.5x5.1m, 16b,2st, 25000hp, 27kts, 354p; 60belt, 40deck, 50shields, 100CT; 7x1-149/42, 2x1-88/45, (2+2x1)-500TT(7), 2x1-500TT(8), 120mines
		8	Stralsund	1912		
	Graudenz 2	9	Graudenz	1914		6382t, 142.7x13.8x6.1m, 12b,2st, 26000hp, 27.5kts, 385p; 60belt, 40deck, 50shields, 100CT; 7x1-149/42, 2x1-88/45, (2+2x1)-500TT(9), 4x1-500TT(10), 120mines
10		Regensburg	1915			
	Königsberg 1	11	Königsberg	1916		7125t, 151.4x14.2x6.3m, 12b,2st, 31000hp, 27.5kts, 475p; 60belt, 40deck, 50shields, 100CT; 8x1-149/42, 2x1-88/45, (2+2x1)-500TT, 200mines
CLL	Grille	1	Grille	1858		491t, 56.9x7.4x3.2m, 2b,1hc, 760hp, 14.4kts, 70p; 2x5-37/20
	Blitz	2	Blitz	1883		1486t, 78.4x9.9x4.4m, 8b,2hc, 2700hp, 15.6kts, 134p; 6x1-88/27, (2x1+1)-350TT
3		Pfeil	1884			
AMC	-	1	Möwe	1914		9800t, 124.5x14.4m, 5b,1vte, 3200hp, 14kts; 4x1-149/43, 1x1-105/42, 2x1-500TT, 500mines





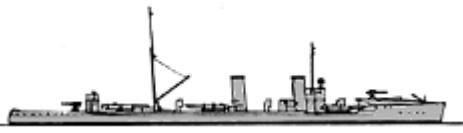
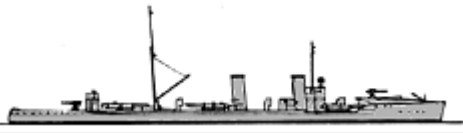
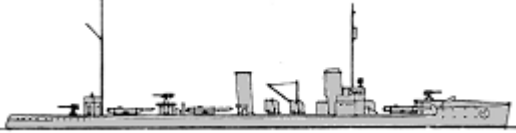

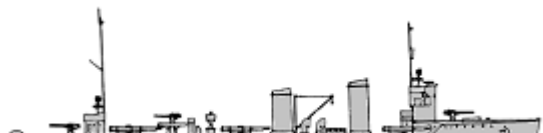
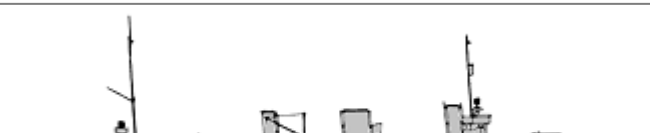
## TORPEDO SHIPS

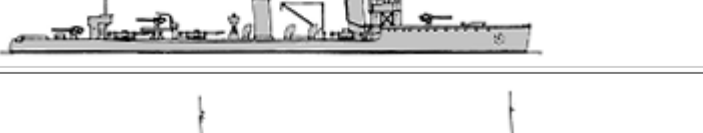
D1	2	1	D1	1887		300t, 56.1x6.6x3.4m, 2b,1vte, 2000hp, 20.6kts, 46p; 3x1-50/37, (1+2x1)-350TT
		2	D2	1887		
D3	2	3	D3	1888		300t, 57.6x6.8x3.2m, 2b,1vte, 2200hp, 20.3kts, 46p; 3x1-50/37, (1+2x1)-350TT
		4	D4	1888		
D5	2	5	D5	1889		406t, 59.6x7.4x3.5m, 2b,1vte, 3200hp, 22.6kts, 46p; 3x1-50/37, (1+2x1)-350TT
		6	D6	1889		
D7	2	7	D7	1891		410t, 59.7x7.4x3.4m, 2b,1vte, 3600hp, 22.5kts, 46p; 3x1-50/37, (1+2x1)-450TT
		8	D8	1891		
D9	1	9	D9	1894		458t, 63.0x7.7x3.7m, 3b,1vte, 4200hp, 23.5kts, 52p; 3x1-50/37, (1+2x1)-450TT
S90	10	10	T91	1900		394t, 63.0x7.0x2.8m, 3b,2vte, 5900hp, 27kts, 57p; 2x1-88/27(11), 3x1-50/37(10,12-19), 3x1-450TT
		11	T92	1900		
		12	T93	1900		
		13	T94	1900		
		14	T95	1900		
		15	T96	1900		
		16	T97	1900		
		17	T98	1900		
		18	T99	1900		
		19	T101	1901		
S102	6	20	T102	1901		406t, 63.2x7.0x2.7m, 3b,2vte, 5900hp, 28kts, 57p; 1x1-88/27(20-22), 2x1-50/37(20-22), 3x1-50/37(23-25), 3x1-450TT
		21	T103	1901		
		22	T104	1901		
		23	T105	1901		
		24	T106	1901		
		25	T107	1902		
G108	6	26	T108	1902		440t, 65.8x6.7x2.9m, 3b,2vte, 6600hp, 28kts, 57p; 2x1-88/42(26), 2x1-88/27(28), 1x1-88/27(31), 3x1-50/37(27,29,30), 2x1-50/37(31), 3x1-450TT
		27	T109	1902		
		28	T110	1903		
		29	T111	1902		
		30	T112	1902		
		31	T113	1902		
S114	1	32	T114	1902		415t, 63.2x7.0x2.7m, 3b,2vte, 5900hp, 27kts, 57p; 3x1-50/37, 3x1-450TT

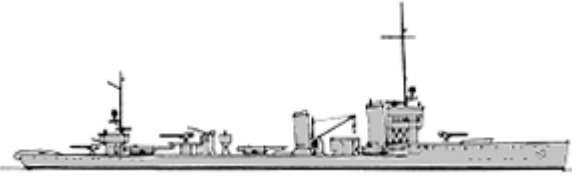
						
S120	2	33	T120	1904		468t, 64.7x7.0x2.6m, 3b,2vte, 6400hp, 27.5kts, 61p; 1x1-88/27, 2x1-50/37, 3x1-450TT
		34	T121	1904		
S125	1	35	T125	1905		454t, 64.7x7.0x3.2m, 3b,3st, 6600hp, 28kts, 61p; 3x1-50/37, 3x1-450TT
S126	5	36	T126	1905		482t, 64.7x7.0x2.8m, 3b,2vte, 6400hp, 28kts, 61p; 2x1-88/42(39), 1x1-88/27(36-38,40), 2x1-50/37(36-38,40), 3x1-450TT
		37	T127	1905		
		38	T128	1905		
		39	T130	1905		
		40	T131	1905		
G132	5	41	T132	1906		544t, 65.7x7.0x2.9m, 3b,2vte, 7000hp, 28kts, 69p; 2x1-88/42(45), 1x1-88/32(41-44), 2x1-52/51(41-44), 3x1-450TT
		42	T133	1906		
		43	T134	1907		
		44	T135	1907		
		45	T136	1907		
G137	1	46	T137	1907		693t, 71.5x7.7x3.2m, 4b,3st, 10800hp, 30kts, 81p; 1x1-88/32, 3x1-52/51, 3x1-450TT
S138	11	47	T139	1907		684t, 70.7x7.8x2.8m, 4b,2vte, 11000hp, 30.3kts, 80p; 2x1-88/42(54), 2x1-88/32(47-50,52,53,55-57), 1x1-88/32(51), 1x1-52/51(47-49,53,55-57), 3x1-52/51(51), 3x1-450TT
		48	T140	1907		
		49	T141	1907		
		50	T142	1907		
		51	T143	1907		
		52	T144	1907		
		53	T145	1907		
		54	T146	1907		
		55	T147	1908		
		56	T148	1908		
57	T149	1908				
V150	10	58	T151	1908		691t, 72.5x7.8x3.0m, 4b,2vte, 10900hp, 30kts, 84p; 2x1-88/42(60,62), 2x1-88/32(58,59,61), 2x1-88/27(63-67), 3x1-450TT
		59	T152	1908		
		60	T153	1908		
		61	T154	1908		
		62	T155	1908		
		63	T156	1908		
		64	T157	1908		

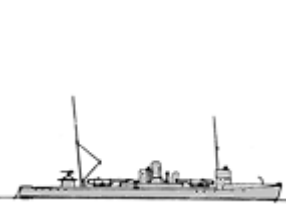

DD		65	T158	1908			
		66	T159	1908			
		67	T160	1908			
	V161	1	68	T161	1908	687t, 72.5x7.8x3.0m, 4b,2st, 14800hp, 32kts, 84p; 2x1-88/27, 3x1-450TT	
	V162	2	69	T163	1909		739t, 73.9x7.9x3.1m, 4b,2gt(69)-4b,2st(70), 15100hp, 32kts, 84p; 2x1-88/27, 3x1-450TT
			70	T164	1909		
	G169	5	71	T169	1909		777(71,72)-778(73)-824(74,75)t, 74.0x7.9x2.8(71-73)-3.0(74,75)m, 4b,3st(71,72)-4b,2st(73-75), 15000hp, 32kts, 84p; 2x1-88/42(72-75), 2x1-88/27(71), 3x1-450TT(71-73), 4x1-500TT(74,75)
			72	T170	1909		
			73	T173			
			74	T174			
75			T175				
S176	3	76	T176	1910		781t, 74.2x7.9x3.1m, 4b,2st, 17600hp, 32kts, 84p; 2x1-88/42, 4x1-500TT	
		77	T178	1910			
		78	T179	1911			
V180	9	79	T180	1910		783(79-84)-775(85-87)t, 73.9x7.9x3.1m, 4b,2st, 18000hp, 32kts, 84p; 2x1-88/42, 4x1-500TT	
		80	T181	1910			
		81	T182	1910			
		82	T183	1910			
		83	T184	1910			
		84	T185	1910			
		85	T186	1911			
		86	T189	1911			
G192	5	87	T190	1911		810t, 74.0x7.9x3.0m, 4b,2st, 18200hp, 32kts, 76p; 2x1-88/42, 4x1-500TT	
		88	T192	1911			
		89	T193	1911			
		90	T195	1911			
		91	T196	1911			
S165	4	92	T197	1911		765t, 74.2x7.9x3.0m, 4b,2st, 17500hp, 32kts, 84p; 2x1-88/42(93,96), 2x1-88/27(94,95), 1x1-88/27(96), 3x1-450TT	
		93	T165	1911			
		94	T166	1911			
		95	T167	1911			
V1	5	96	T168	1911		697t, 71.1x7.6x3.1m, 4b,2st, 17000hp, 32kts, 74p; 2x1-88/42, 4x1-500TT, 18mines	
		97	V1	1912			
		98	V2	1912			
		99	V3	1912			
		100	V5	1913			

		101	V6	1913		
G7	4	102	G7	1912		719t, 71.5x7.6x3.0m, 4b,2st, 16000hp, 32kts, 74p; 2x1-88/42, 4x1-500TT, 18mines
		103	G8	1912		
		104	G10	1912		
		105	G11	1912		
		106	S18	1913		
S13	3	107	S19	1913		695t, 71.5x7.4x2.8m, 4b,2st, 15700hp, 32.5kts, 74p; 2x1-105/43(106,108), 2x1-88/42(107), 4x1-500TT, 18mines
		108	S23	1913		
		109	V26	1914		
V25	2	110	V28	1914		975t, 78.5x8.3x3.6m, 3b,2st, 23500hp, 33.5kts, 83p; 3x1-88/42, (2x2+2x1)-500TT, 24mines
		111	V43	1915		
V43	3	112	V44	1915		1106t, 79.6x8.3x4.0m, 3b,2st, 24000hp, 34.5kts, 87p; 3x1-88/42, (2x2+2x1)-500TT, 24mines
		113	V46	1915		
		114	V71	1916		
V67	2	115	V79	1916		1188t, 82.0x8.3x3.9m, 3b,2st, 23500hp, 34kts, 85p; 3x1-105/42, (2x2+2x1)-500TT, 24mines
		116	G95	1916		
G85	1	116	G95	1916		1147t, 83.0x8.4x3.5m, 3b,2st, 24000hp, 33.5kts, 87p; 3x1-105/42, (2x2+2x1)-500TT, 24mines
B97	2	117	B97	1915		1843t, 98.0x9.4x3.9m, 4b,2st, 40000hp, 36.5kts, 114p; 4x1-105/42, (2x2+2x1)-500TT, 24mines
		118	B98	1915		
V125	1	119	V130	1918		1188t, 82.0x8.3x4.1m, 3b,2st, 23500hp, 34kts, 105p; 3x1-105/42, (2x2+2x1)-500TT, 24mines
V116	1	120	V116	1918		2360t, 107.5x10.4x4.5m, 4b,2st, 45000hp, 34.5kts, 188p; 4x1-149/42, 2x2-600TT, 40mines

	H145	1	121	H146	1918		1147t, 84.5x8.4x3.5m, 3b,2gt/gt, 24500hp, 32kts, 105p; 3x1-105/42, (2x2+2x1)-500TT, 24mines
TB	S7	4	1-4	T13-15, 20	1885		98t, 37.7x4.9x2.2m, 1b,1vte, 725hp, 20.4kts, 16p; 1x1-50/37, (1+2x1)-350TT
	S24	1	5	T28	1886		103t, 37.7x4.8x2.3m, 1b,1vte, 840hp, 19.1kts, 16p; 1x1-50/37, (1+2x1)-350TT
	V105	3	6	V105	1915		421t, 62.6x6.2x2.5m, 4b,2st, 5500hp, 60p; 2x1-88/42(6), 2x1-88/27(8), 2x1-52/51(7), 2x1-450TT
			7	V106	1915		
			8	V108	1915		
	A1	8	9	A1	1915		137t, 41.6x4.6x1.5m, 1b,1vte, 1200hp, 20kts, 28p; 1x1-52/51, 2x1-450TT, 4mines, sweep
			10	A17	1915		
			11	A18	1915		
			12	A21	1915		
			13	A22	1915		
			14	A23	1915		
			15	A24	1915		
			16	A25	1915		
	A26	17	17	A26	1916		250t, 50.0x5.3x2.3m, 1b,1gt, 3250hp, 25kts, 29p; 2x1-88/27, 1x1-450TT, sweep
			18	A27	1916		
			19	A28	1916		
			20	A29	1916		
21			A31	1916			
22			A33	1916			
23			A34	1916			
24			A35	1916			
25			A36	1916			
26			A37	1916			
27			A38	1917			
28			A39	1916			
29			A41	1917			
30			A44	1917			
31			A45	1917			
32			A46	1917			
33			A48	1917			
A50	4	34	A52	1917		252t, 50.0x5.6x2.3m, 1b,1gt, 3250hp, 25kts, 29p; 2x1-88/27, 1x1-450TT, sweep	
		35	A53	1917			
		36	A54	1917			





Anneliese	1	6	Niendorf	1917	No picture	445t, 38.7x6.9x2.8m, 1b,1vte, 400hp, 10kts, 31p; 1x1-88/27
Loki	2	7	Loki	1916	No picture	545t, 38.7x7.2x3.3m, 1b,1vte, 540hp, 12kts, 31p; 1x1-88/27
		8	Forseti	1917		
Aldebaran	3	9	Aldebaran	1916	No picture	550t, 39.0x7.1x3.3m, 1b,1vte, 500hp, 11kts, 31p; 1x1-88/27
		10	Koldewey	1917		
		11	Papenburg	1919		
Grasbrook	6	12	Grasbrook	1916	No picture	475t, 38.8x7.0x2.9m, 1b,1vte, 400hp, 10kts, 31p; 1x1-88/27
		13	Harvesterhude	1916		
		14	Wangeroog	1917		
		15	Spiekeroog	1917		
		16	Admiral von Schröder	1918		
		17	Admiral von Pohl	1918		
Geier	3	18	Immelmann	1917		600t, 42.7x7.0x3.7m, 1b,1vte, 400hp, 10kts, 31p; 1x1-88/27
		19	Georg Rhode	1917		
		20	Graf Zeppelin	1917		
Augustenburg	1	21	Geheimrat Schütt	1917		490t, 40.0x7.0x3.1m, 1b,1vte, 400hp, 9.5kts, 31p; 1x1-88/27
Ditmar Koel	1	22	Hein Godenwind	1918	No picture	450t, 39.5x7.3x2.8m, 1b,1vte, 400hp, 10kts, 31p; 1x1-88/27
Von der Goltz	6	23	Von der Goltz	1916	No picture	460t, 36.7x7.4x2.9m, 1b,1vte, 400hp, 10kts, 31p; 1x1-88/27
		24	Emmich	1917		
		25	Usedom	1917		
		26	Wollin	1918		
		27	Von Laffert	1919		
		28	Graf Luckner	1919		
Kattegat	3	29	Kattegat	1916	No picture	550t, 41.5x7.0x3.2m, 1b,1vte, 400hp, 10kts, 31p; 1x1-88/27
		30	Großadmiral von Tirpitz	1917		
		31	Admiral Souchon	1918		
Neuwerk	2	32	Reiherstieg	1916	No picture	470t, 36.6x7.4x4.0m, 1b,1vte, 400hp, 10.5kts, 31p; 1x1-88/27
		33	Herzog Albrecht	1918		
Flensburg	3	34	Mürwik	1917		257brt, 43.2x7.1xm, 1b,1vte, 450hp, 11kts, 31p; 1x1-88/27
		35	Gravenstein	1917		
		36	Apenrade	1918		
Einswarden	4	37	Elsfleth	1918	No picture	560t, 39.6x7.1x3.3m, 1b,1vte, 450hp, 10kts, 31p; 1x1-88/27
		38	Elmshorn	1918		
		39	Großherzog Friedrich August	1918		
		40	Emden	1918		
Mackensen	1	41	Thiele	1919	No picture	475t, 37.5x7.3x2.9m, 1b,1vte, 400hp, 10kts, 31p; 1x1-88/27
Admiral Scheer	2	42	Admiral Scheer	1917	No picture	475t, 37.5x7.3x2.9m, 1b,1vte, 400hp, 10kts, 31p; 1x1-88/27

TL

			43	Ottendorf	1919		
	Heilbutt	3	44	Heilbutt	1917		560t, 39.6x7.1x3.4m, 1b,1vte, 490hp, 11kts, 31p; 1x1-88/27
			45	Seeteufel	1917		
			46	Königsberg	1918		
			47	Maerker	1918		
	Seelöwe	4	48	Bunnemann	1918	No picture	600t, 38.2x7.1x3.7m, 1b,1vte, 420hp, 10kts, 31p; 1x1-88/27
			49	Georg Hoffmann	1919		
			50	Tietze	1919		
			51	Danzig	1918		
	Danzig	2	52	Nogat	1918	No picture	550t, 38.7x7.2x3.3m, 1b,1vte, 540hp, 12kts, 31p; 1x1-88/27
			53	Osnabrück	1918		
	Osnabrück	2	54	Münster	1918	No picture	660t, 40.0x7.2x3.8m, 1b,1vte, 425hp; 1x1-88/27
ATL	-		1	Ludwig	1912		222t



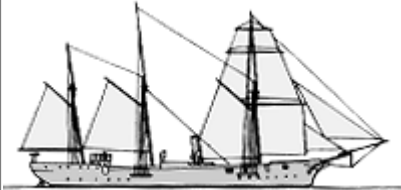
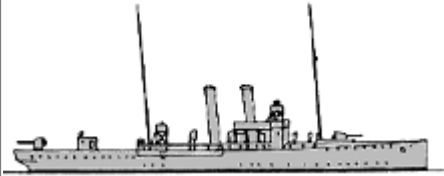





## OTHER FIGHTING SHIPS

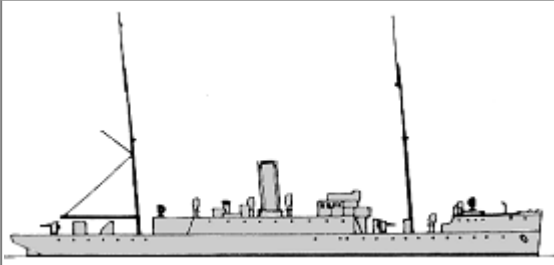

PG	Wolf	1	1	Hyäne	1879		570t, 47.2x7.7x3.4m, 2b,1hse, 340hp, 8.5kts, 106p; 2x1-125/21, 2x1-87/22, 3x5-37/20
	Illtis	1	2	Panther	1902		1193t, 66.9x9.7x3.1m, 4b,2vte, 1300hp, 14kts, 130p; 2x1-105/37

## COASTAL FORCES

PT	L7	1	1	LM10	1917		7t, 16.0x2.4x0.7m, 3pe, 720hp, 31.8kts, 7p; 1-450TT
	L14	4	2-5	LM14, 16, 27, 28	1917-1919		7t, 16.5x2.4x0.6m, 3pe, 720hp, 31.6kts, 7p; 1-450TT
	L17	1	6	LM20	1917		8t, 17.0x2.4x0.6m, 3pe, 720hp, 30.8kts, 7p; 1x1-20/60, 1-450TT
	L21	3	7-9	LM21-23	1917-1919		7t, 16.0x2.4x0.7m, 3pe, 720hp, 31.8kts, 7p; 1x1-20/60(7), 1-450TT(7)
PS	UZ1a	12	1-12	UZ1a-12a	1916-1918	No picture	16-27t, 17.5-21.5x3.2-4.0x0.9-1.2m, 2pe, 120-360hp, 10-17.4kts, 11p;
	UZ1	22	13-34	UZ1-22	1917		48-53t, 26.0-27.5x3.9-4.3x1.0-1.5m, 2-3pe, 420-640hp, 14-16.4kts, 13-14p; 1x1-52/51, dcr, sweep
	UZ23	10	35-44	UZ23-30, 34, 35	1918		60t, 31.0x4.4x1.3m, 2pe, 570hp, 16kts, 13-14p; 1x1-52/51(43), dcr

## MINE WARFARE SHIPS

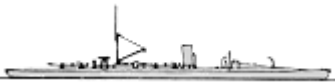
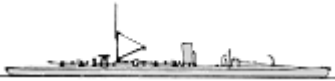
ML	Pelikan	1	1	Pelikan	1891		2424t, 84.2x11.7x5.1m, 2b,2vte, 3000hp, 15kts, 195p; 4x1-88/27, 400mines
	MW I	2	2	MW I	1917		673t, 53.1x9.3x2.3m, 2b,2vte, 371hp, 9.5kts, 53p; mines
3			MW II	1917			
S7	3	1-3	T11, 16, 22	1885		98t, 37.7x4.9x2.2m, 1b,1vte, 725hp, 20.4kts, 16p; 1x1-50/37, sweep	
S24	5	4	T24	1886		103t, 37.7x4.8x2.3m, 1b,1vte, 840hp, 19.1kts, 16p; 1x1-50/37, sweep	
		5	T27	1886			
		6	T29	1886			
		7	T30	1887			
		8	T31	1887			
S33	8	9	T33	1887		113t, 39.9x4.8x2.3m, 1b,1vte, 1100hp, 20kts, 16p; 1x1-50/37, sweep	
		10	T34	1887			
		11	T35	1887			
		12	T36	1887			
		13	T37	1887			
		14	T38	1887			
		15	T39	1887			
		16	T40	1887			
S42	1	17	T42	1889		153t, 44.2x5.0x2.6m, 1b,1vte, 1420hp, 22.2kts, 16p; 1x1-50/37, sweep	
S43	5	18	T44	1889		152t, 44.2x5.0x2.7m, 1b,1vte, 1571hp, 21.5kts, 16p; 1x1-50/37, sweep	
		19	T45	1889			
		20	T49	1890			
		21	T53	1890			
		22	T55	1890			
S58	4	23	T60	1892		152t, 44.3x5.0x2.6m, 1b,1vte, 1232hp, 20.2kts, 16p; 1x1-50/37, sweep	
		24	T61	1892			
		25	T62	1892			
		26	T63	1892			
S67	5	27	T69	1893		166t, 47.9x5.4x2.6m, 1b,1vte, 1600hp, 21.9kts, 24p; 1x1-50/37, sweep	
		28	T70	1893			
		29	T71	1893			

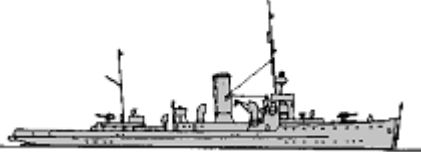
						
		30	T72	1893		
		31	T73	1894		
S74	1	32	T74	1895		186t, 49.9x5.5x2.8m, 2b,1vte, 2500hp, 23.7kts, 24p; 1x1-50/37, sweep
S75	6	33	T75	1895		180t, 49.0x5.3x2.9m, 2b,1vte, 1744hp, 22.3kts, 24p; 1x1-50/37, sweep
		34	T76	1895		
		35	T77	1895		
		36	T79	1895		
		37	T80	1895		
		38	T81	1896		
S82	6	39	T82	1897		170t, 48.2x5.1x2.6m, 2b,1vte, 2146hp, 25.3kts, 29p; 1x1-50/37, sweep
		40	T83	1897		
		41	T84	1897		
		42	T85	1898		
		43	T86	1898		
		44	T87	1898		
G88	2	45	T88	1898		177t, 48.7x5.0x2.8m, 2b,1vqe, 2468hp, 26kts, 29p; 1x1-50/37, sweep
		46	T89	1898		
M1	15	47	M1	1915		456(47-51)-476(52-61)t, 55.1(47-51)-56.4(52-61)x7.3x2.0m, 2b,2vte, 1400(47-51)-1600(52-61)hp, 16.3(47-51)-16.2(52-61)kts, 40p; 2x1-88/27, 30mines, sweeps
		48	M2	1915		
		49	M3	1915		
		50	M4	1915		
		51	M5	1915		
		52	M7	1915		
		53	M8	1915		
		54	M10	1915		
		55	M13	1915		
		56	M17	1916		
		57	M18	1915		
		58	M19	1915		
		59	M20	1915		
		60	M21	1915		
		61	M25	1915		
		62	M28	1916		
		63	M29	1916		
		64	M30	1916		
		65	M32	1916		
		66	M33	1916		

MS	M27	20	67	M34	1916
			68	M35	1916
			69	M37	1916
			70	M38	1916
			71	M42	1916
			72	M43	1916
			73	M44	1916
			74	M45	1916
			75	M46	1916
			76	M48	1916
			77	M50	1916
			78	M51	1916
			79	M52	1916
			80	M53	1916
			81	M54	1916
			82	M57	1917
			83	M58	1917
84	M59	1917			
85	M60	1918			
86	M61	1918			
87	M65	1917			
88	M66	1917			
89	M69	1917			
90	M70	1917			
91	M71	1918			
92	M72	1918			
93	M73	1918			
94	M74	1918			
95	M75	1917			
96	M76	1917			
97	M77	1917			
98	M78	1917			
99	M79	1919			
100	M80	1919			
101	M81	1919			
102	M82	1919			
103	M84	1917			
104	M85	1918			
105	M86	1918			
106	M87	1917			
107	M88	1917			

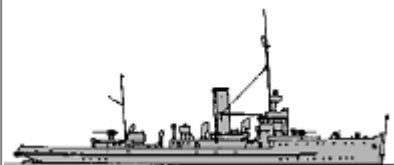

507(62-73)-513(74-76,81)-503(77-80)t, 58.4(62-73)-58.3(74-76,81)-58.2(77-80)x7.3x2.3m, 2b,2vte, 1800(62-76,81)-1890(77-80)hp, 16.5(62-73,77-80)-16.3(74-75,81)kts, 40p; 2x1-105/42(62-71), 3x1-88/42(72-81), 30mines, sweeps



M57

69

108	M89	1918
109	M90	1918
110	M93	1918
111	M94	1918
112	M96	1918
113	M97	1918
114	M98	1918
115	M99	1918
116	M100	1918
117	M101	1918
118	M102	1918
119	M103	1918
120	M104	1918
121	M105	1918
122	M106	1919
123	M107	1918
124	M108	1918
125	M109	1918
126	M110	1918
127	M111	1918
128	M112	1919
129	M115	1918
130	M116	1918
131	M117	1919
132	M118	1919
133	M119	1918
134	M120	1918
135	M121	1918
136	M122	1919
137	M125	1919
138	M126	1919
139	M129	1919
140	M130	1919
141	M132	1919
142	M133	1919
143	M135	1919
144	M136	1919
145	M137	1919
146	M138	1919
147	M144	1919



535(82-86)-539(87-90,95-98,106-109)-553(91-94,99-105,110-112)-548(113-116,123-128,145,146)-564(117,118,129-132)-560(119,120,133-136,147,148)-550(121,122,137-144,149,150), 59.3(82-90,95-112,117,118,129-132)-58.2(91-94)-59.6(113-116,119-128,133-141,145-150)-59.5(142-144)x7.3-7.4x2.2-2.3m, 2b,2vte, 1600-1870hp, 15-16.5kts, 40p; 2x1-105/42(82-88,113-121,123-127,129,130,133-135), 2x1-88/42(89-94,104-112), 3x1-88/42(95-98,103), 30mines, sweeps

			148	M145	1919		
			149	M146	1919		
			150	M157	1919		
	FM1	11	151	FM1	1918		193t, 43.0x6.0x1.7m, 1b,2vte, 600hp, 14kts, 35p; 1x1-88/27, sweeps
			152	FM2	1918		
			153	FM4	1918		
			154	FM19	1918		
			155	FM20	1918		
			156	FM21	1919		
			157	FM22	1919		
			158	FM24	1919		
			159	FM25	1918		
			160	FM26	1918		
			161	FM31	1919		
	FM37	1	162	FM42	1919		205t, 45.5x6.0x1.7m, 1b,2vte, 750hp, 14.3kts, 35p; 1x1-88/27, sweeps
MSL	F1	54	1-54	F1, 4-15, 17, 20, 21, 23, 25, 27, 34, 37-39, 41, 43-47, 49-55, 58-75	1915-1919		20-21t, 16.5-17.5x4.0x1.1m, 2pe, 120-130hp, 10-11kts, 7p; 1x5-37/20(24-54), 1x1-450TT(3,4,9), sweeps

[home](#)[World navies yesterday](#)[1920](#)

# Greece 01 January 1920

## BATTLESHIPS

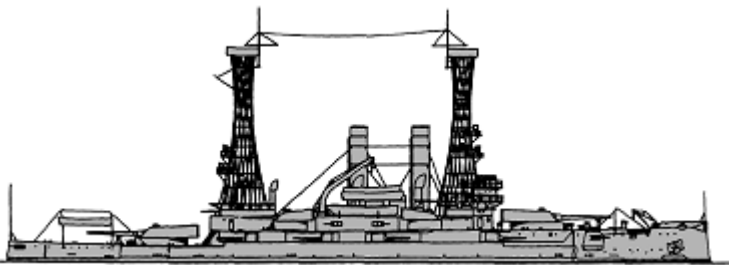
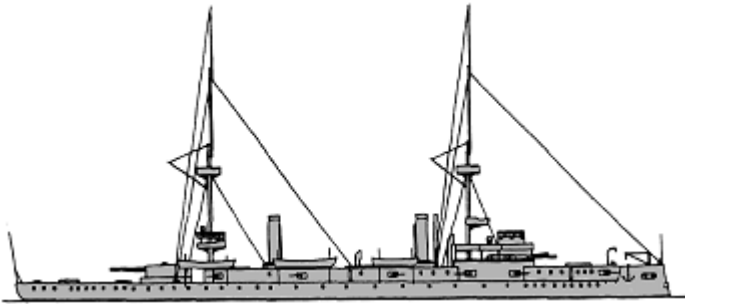
BB	Kilkis	1	Kilkis	1908		14465t, 116.4x23.5x7.5m, 8b,2vte, 10000hp, 17kts, 744p; 229belt, 37deck, 305turrets, 229CT; 2x2-305/45, 4x2-203/45, 8x1-178/45, 12x1-76/50, 6x1-47/40, 2x1-37/40, 2-533TT
		2	Limnos	1908		
BC	Idra	1	Idra	1892		4885t, 102.0ppx15.8x5.5m, 4b,2vte, 6700hp, 17kts, 440p; steel, compound- 305belt, 57deck, 350casemate, 305barbette; 3x1-150/45, 6x1-37/20
		2	Spetsai	1892		
		3	Psara	1891		

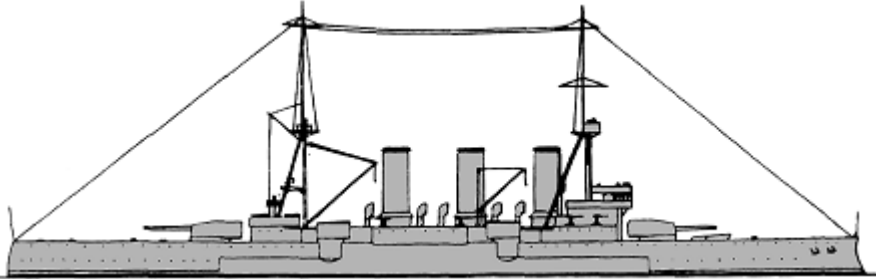
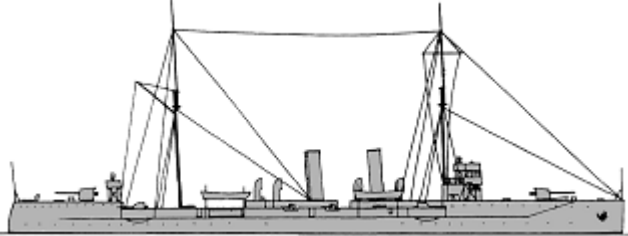

## CRUISERS

CA	Averof	1	Averof	1911		10200t, 140.8x21.0x7.5m, 22b,2vte, 19000hp, 22.5kts, 670p; 200belt, 50deck, 140turrets, 180CT; 2x2-234/45, 4x2-190/45, 17x1-76/40, 4x1-47/40, 3-450TT
CL	Elli	1	Elli	1913		2750t, 98.1x11.9x4.3m, 3b,3st, 7500hp, 20kts, 232p; 51slopes, 25deck, 50CT; 2x1-152/45, 4x1-102/50, 2x1-76/40, 1x1-57/40, 8x1-47/40, 2x1-37/27, 2x1-450TT

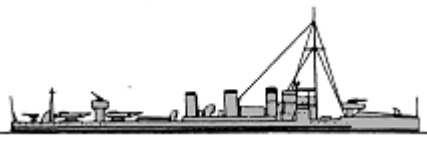
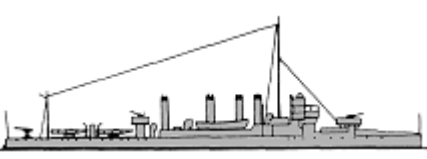
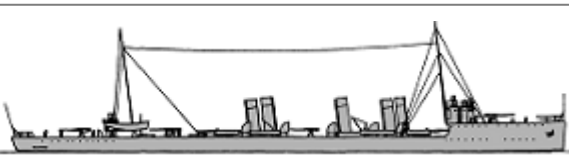

CLL	Navarchos Miaoulis	1	1	Navarchos Miaoulis	1879	No picture	1820t, 75.0ppx11.0x4.4m, 1hc, 2400hp, 13.5kts, 180p; 3x1-173/22, 1x1-173/17, 6x1-37/20, 3-356TT
-----	--------------------	---	---	--------------------	------	------------	---

## TORPEDO SHIPS

DD	Niki	3	1	Niki	1906		350t, 67.0x6.6x2.7m, 4b,2vte, 6800hp, 30kts, 58p; 2x1-76/51, 4x1-57/59, 2x1-450TT	
			2	Aspis	1907			
			3	Velos	1907			
	Thyella	4	4	Thyella	1907		380t, 67.1x6.2x1.8m, 4b,2vte, 30kts, 70p; 2x1-76/51, 4x1-57/59, 2x1-450TT	
			5	Nafkratoussa	1906			
			6	Lonchi	1907			
			7	Sfendoni	1907			
	Aetos	4	8	Aetos	1912		1175t, 89.3x8.5x2.6m, 5b,2st, 22000hp, 32kts, 90p; 4x1-102/50, 1x1-57/40(8-10), 4x1-533TT	
			9	Ierax	1912			
			10	Leon	1912			
			11	Panthur	1912			
	Smyrni	1	12	Smyrni	1906		420t, 68.4x6.3x1.9m, 4b,2vte, 6000hp, 28.4kts, 65p; 1x1-75/27, 5x1-66/27, 2x1-450TT	
	TB	Aigli	6	1	Aigli	1912		125t, 45.0x5.0x1.2m, 2b,1vte, 2400hp, 24kts, 20p; 2x1-57/45, 3x1-450TT
				2	Alkyoni	1914		
				3	Arethousa	1913		
4				Doris	1913			
5				Dafni	1913			
6				Thetis	1913			

## SUBMARINES

SS	Delfin	2	1	Delfin	1912		310/460t, 50.0x4.7x2.7m, 2d/em, 720/460hp, 13/8.5kts, 24p; 5-450TT
			2	Xifias	1913		

## OTHER FIGHTING SHIPS

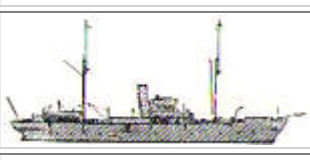
PG	Afroessa	1	1	Plixavra	1857	No picture	380t, 38.0x7.0x2.7m, 160hp, 9kts; 1x1-87/22
	Sfaktiria	2	2, 3	Alfa, Beta	1880	No picture	52t, 22.0x4.5x1.5m; 1x1-149/24, 1spar torpedo
	Hydra	2	4	Amvrakia	1881	No picture	470t, 39.0ppx7.9x2.2m, 2vc, 690hp, 12kts, 64p; 1x1-263/27, 4x1-47/40(6), 1-356TT
			5	Aktion	1881		
	Achelaos	4	6	Achelaos	1884		400-420t, 41.0-42.0x7.4-7.6x3.5-4.0m, vc, 400hp, 9.8(6)-10.5(7)kts, 73p; 2x1-95/26, 2x1-37/20(6), 3x1-37/20(7)
7	Eurotas	1884					

Aidon	1	8	Aidon	1884	No picture	86t
Kichli	2	9, 10	Kichli, Kissa	1884	No picture	86t, 24.2x4.9x2.1m, 1vc, 162hp, 10kts

## MINE WARFARE SHIPS

ML	Aigialeia	3	1	Aigialeia	1881	No picture	300t, 23.0x4.0x2.6m, 1vc, 300hp, 9kts; 20mines
			2	Monemvasia	1881		
			3	Nafplia	1881		
AML	-	3	1	Kanaris	1878		870t, 91.2x9.2m, 500hp, 14kts; 2x1-120/22, 2x5-37/17, 4-356TT, mines
			2	Tenedos	1906		450t; 40mines
			3	Korgialenios	1916		380t; 50mines
AMS	-	5	1	Y1	1910		140t
			2	Y2	1910		140t
			3	Y3	1910		140t
			4	Y4	1910		140t
			5	Aris			

© Ivan Gogin, 2014

[home](#)[World navies yesterday](#)[1920](#)

# Honduras 01 January 1920

## OTHER FIGHTING SHIPS

PG	Tatumbla	1	1	Tatumbla	1900s	No picture	200t, 12kts, 44p; 2x1-small guns
----	----------	---	---	----------	-------	------------	----------------------------------

## COASTAL FORCES

YP	22 Februar	1	1	22 Februar	1897	No picture	13t, 22hp
	Liberia	1	2	Liberia	1908	No picture	24t, 25.9x3.7x1.4m, 1pe, 120hp, 13kts; 1x1-37/27

© Ivan Gogin, 2015



[home](#)[World navies yesterday](#)[1920](#)

# Hungary 01 January 1920

## RIVER FIGHTING SHIPS

RMON	Leitha	1	Leitha	1872		315t, 50.6x8.1x1.1m, 2b,2vte, 700hp, 8kts, 59p; steel- 44side, 25deck, 50CT; 1x1-120/33, 1x1-66/37(1), 1x1-66/16(1), 3x1-66/16(2)
		2	Maros	1872		
	Szamos	1	3	Szamos	1892	
Inn	1	4	Marx	1915		536t, 57.9x10.3x1.3m, 2b,2vte, 1500hp, 13kts, 95p; 40side, 25deck, 50CT; 1x2-120/42, 3x1-120/8, 2x1-66/47

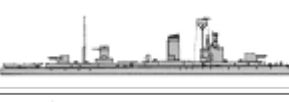
## RIVER FIGHTING BOATS

PGR	Compo	1	Compo	1916		133t, 44.0x6.0x1.0m, 2b,2gst, 1200hp, 15kts, 40p; 8belt, 6deck, 10turrets, 10CT; 2x2-66/24
		2	Viza	1916		
	Komarom	3	Komarom	1918		160t, 45.5x6.0x1.0m, 2b,2gst, 1400hp, 16kts, 42p; 10belt, 6deck, 22turrets, 10CT; 2x1-75/27
		4	Pozsony	1918		
	Hüszar	3	5-7	Honved, Hüszar, Tüzér	1916	

© Ivan Gogin, 2015

[home](#)

[World navies yesterday](#)

[1920](#)

## India 01 January 1920

### ESCORTS

SL	Lawrence	1	1	Lawrence	1919		1412t, 69.6x10.4x3.6m, 2b,2st, 1900hp, 15kts, 119p; 4x1-76/40
----	----------	---	---	----------	------	--	---





© Ivan Gogin, 2014

[home](#)[World navies yesterday](#)[1920](#)

## Italy 01 January 1920

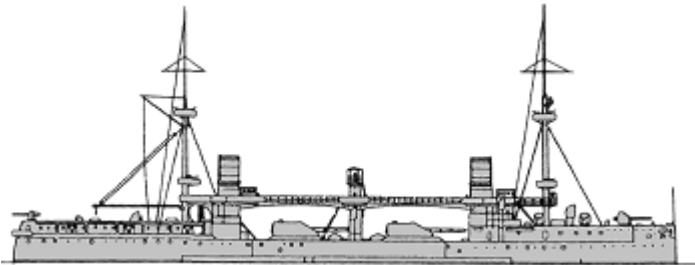
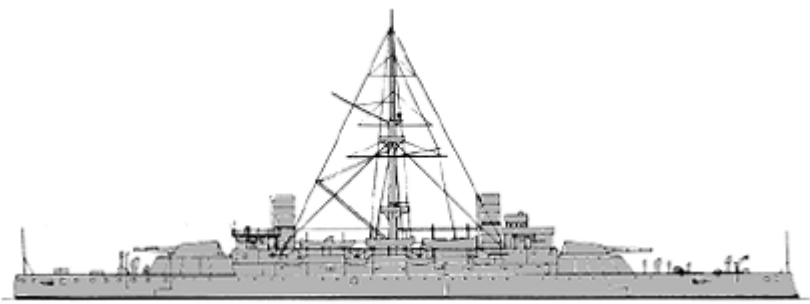
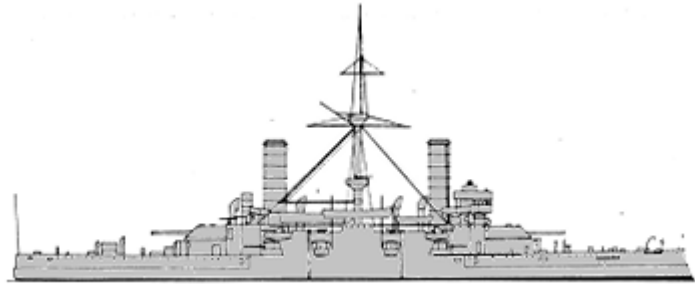
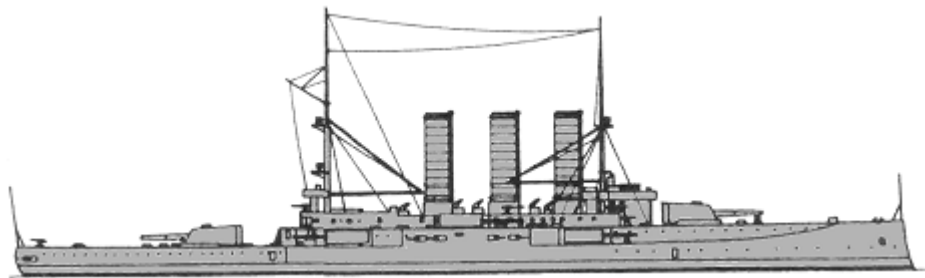
## BATTLESHIPS

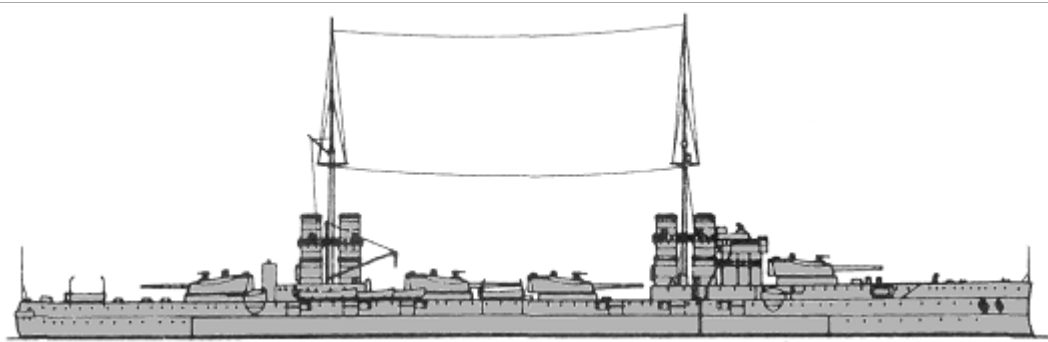
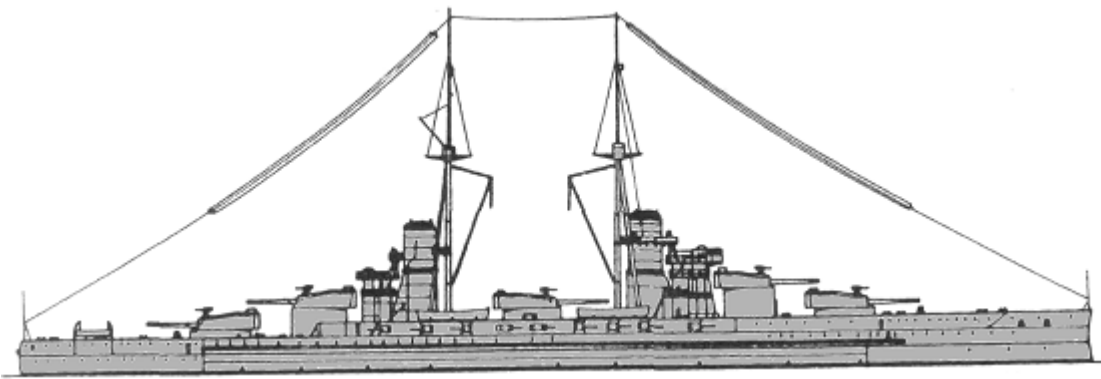
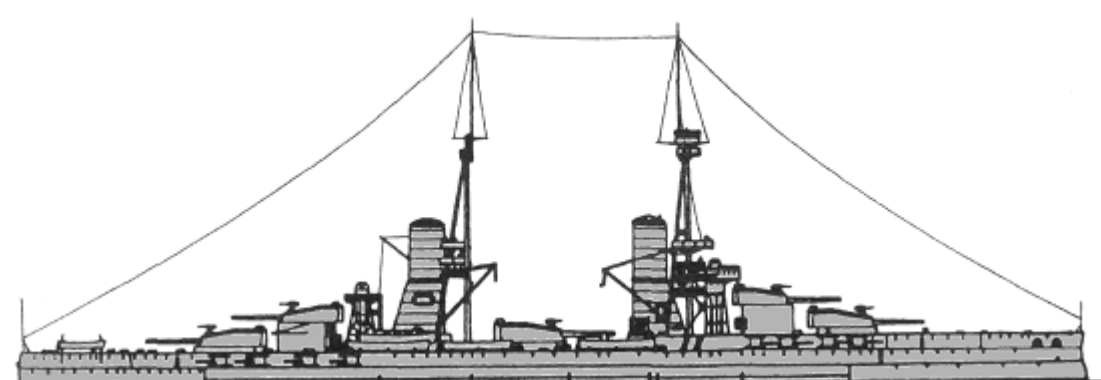
BB	Duilio	1	1	Dandolo	1882		11264t, 109.2x19.7x8.3m, 8b,2vc, 8045hp, 15.6kts, 495p; steel, 550belt, 50deck, 225turrets; 2x2-254/40, 7x1-152/40, 5x1-120/40, 16x1-57/43, 8x5-37/20, 4x1-11.4/94, 4-450TT
	Re Umberto	1	2	Sardegna	1895		15426t, 130.7x23.4x8.8m, 18b,2vte, 22800hp, 20kts, 733-794p; steel, 100belt, 75deck, 100turrets, 300CT; 2x2-343/30, 4x1-76/40
	Ammiraglio di Saint Bon	2	3	Ammiraglio di Saint Bon	1901		9940-10531t, 111.8x21.1x7.7m, 12b,2vte, 14000hp, 18.2kts, 565p; Harvey, 250belt, 70deck, 250turrets, 250CT; 2x2-254/40, 8x1-152/40, 8x1-120/40, 6x1-76/40(4), 8x1-57/43(3), 8x1-47/40(4), 2x1-37/25(3), 4-450TT
			4	Emanuele Filiberto	1902		
	Regina Elena	4	5	Regina Elena	1907		13864-14192t, 144.6x22.4x8.5m, 28b,2vte(5,6)-18b,2vte(7)-22b,2vte(8), 19299-21968hp, 21kts, 764p; Harvey, 250belt, 38deck, 250turrets, 250CT; 2x1-305/40, 6x2-203/45, 16x1-76/40(5,6), 24x1-76/40(7,8), 2x1-47, 2-450TT
6			Vittorio Emanuele	1908			
7			Roma	1908			
8			Napoli	1908			

	Dante Alighieri	1	9	Dante Alighieri	1913		21800t, 168.1x26.6x8.8m, 23b,4st, 32190hp, 22.8kts, 981p; 250belt, 50deck, 250turrets, 280CT; 4x3-305/46, (4x2+12x1)-120/50, 20x1-76/50, 3-450TT, 1seaplane
	Giulio Cesare	10		Giulio Cesare	1914		24250-24801t, 176.1x28.0x9.4m, 24b,4gt(10)-20b,4gt(11), 31000hp, 22kts, 1235p; 250belt, 84deck, 280turrets, 280CT; (3x3+2x2)-305/46, 18x1-120/50, 13x1-76/50, 3-450TT
		2	11	Conte di Cavour	1915		
	Andrea Doria	12		Andrea Doria	1916		24715-24729t, 176.1x28.0x9.5m, 20b,4gt, 30000-31000hp, 21kts, 1233p; 250belt, 54decks, 280turrets, 280CT; (3x3+2x2)-305/46, 16x10-152/45, 19x1-76/50, 3-450TT
		2	13	Caio Duilio	1915		
MON	Faà di Bruno	1	1	Faà di Bruno	1917		2854t, 55.6x27.0x2.2m, 2b,2vte, 465hp, 2.5kts, 743p; 2900concrete belt, 40deck, 110turret; 1x2-381/40, 4x1-76/40, 2x1-40/39
	Monte Grappa	2	2	Monte Grappa	1919	No picture	575-633t, 40.0ppx10.0x1.8m, 2d, 700hp, 7kts; 1x1-381/40
		3	3	Montello	1919		
AMON -		1		Monfalcone			525t; 1x1-305/46
		2		Monte Santo			570t; 1x1-381/40
		3		Monte Sabotino			570t; 1x1-381/40
		4		Monte Cucco			440t; 1x1-305/40
		5		Vodice			440t; 1x1-305/40

		6	Carso			360t; 2x1-190/45
		7	Pasubio			225t; 1x1-152/50

### AIRCRAFT CARRYING SHIPS

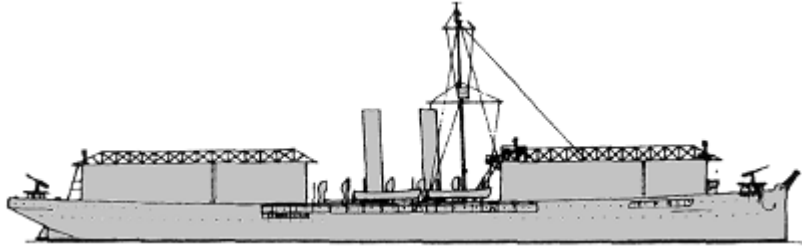
AV	-	1	1	Europa	1895		8805t, 123.2x14.1x5.9m, 1vte, 3000hp, 12.2kts; 2x1-76/30, 8seaplanes
----	---	---	---	--------	------	--	--

### CRUISERS

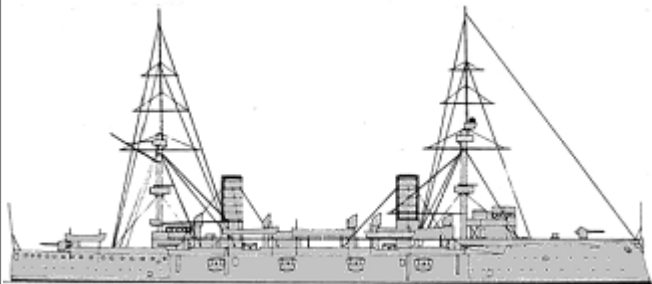
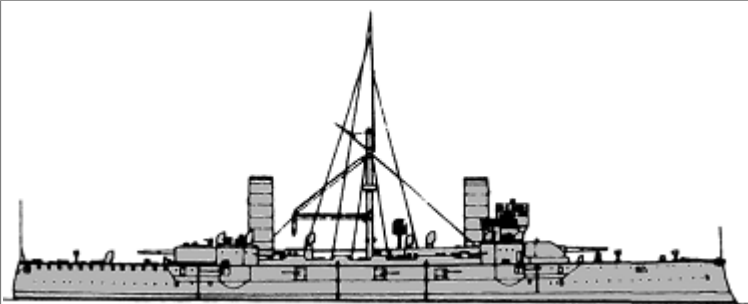
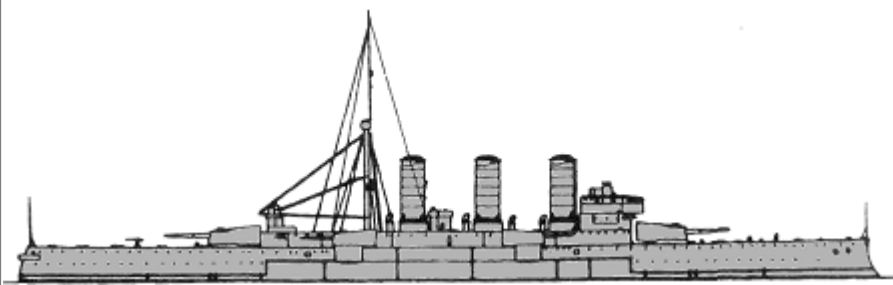
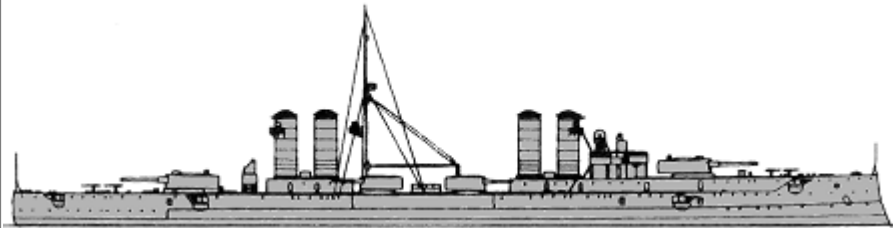
CA				Vettor Pisani	1899		7128t, 105.7x18.0x7.2m, 8b,2vte, 13259hp, 18.6kts, 486p; Harvey, 150belt, 37deck, 150casemates, 150CT; 12x1-152/40, 4x1-120/40, 2x1-75/21, 14x1-57/40, 8x1-37/25, 2x1-11.4/94, 4-450TT	
		2		Varese	1901		7972t, 111.8x18.3x7.1m, 24b,2vte, 13500hp, 19.5kts, 559p; 150belt, 38deck, 150turrets, 150CT; 1x1-254/40, 1x2-203/45, 14x1-152/40, 10x1-76/40, 6x1-47/40, 4-450TT	
		3		Francesco Ferruccio	1905			
		1	4		Pisa	1909		10600t, 140.5x21.0x7.1m, 22b,2vte, 20000hp, 23kts, 687p; 200belt, 130deck, 160turrets, 180CT; 2x2-254/45, 4x2-190/45, 20x1-76/50, 3-450TT
		2	5		San Giorgio	1910		11300(5)-11900(6)t, 140.8x21.0x7.3-7.8m, 14b,2vte(5)-14b,4st(6), 19500(5)-23000(6)hp, 23.2(5)-23.8(6)kts, 698-705p; 200belt, 50deck, 200turrets, 250CT; 2x2-254/45, 4x2-190/45, 16x1-76/50, 3-450TT
	6		San Marco	1911				



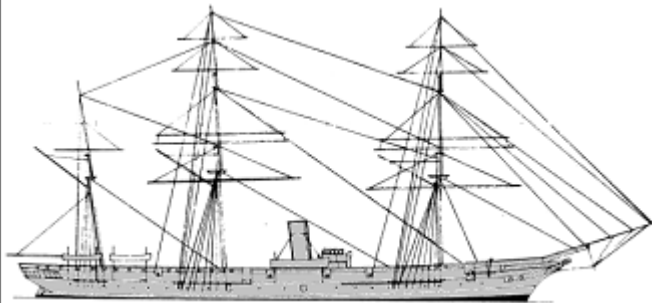
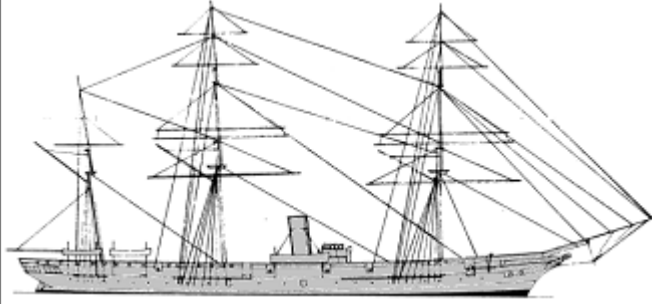
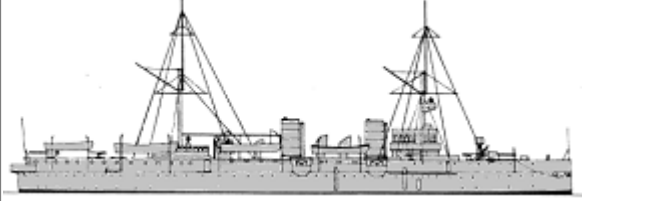
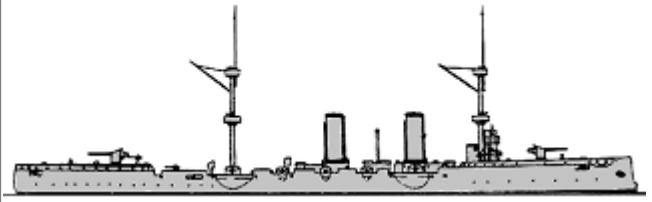
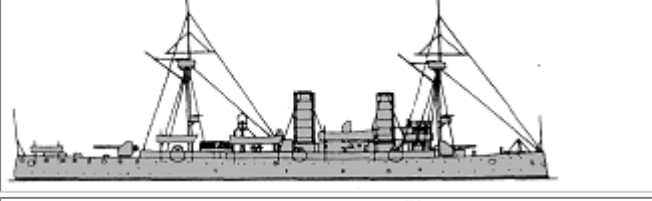
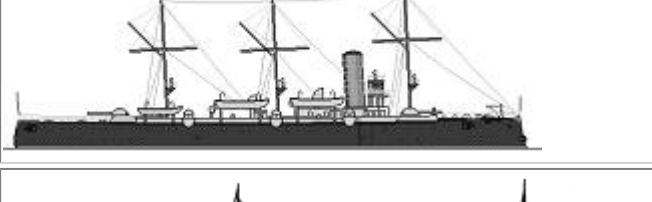
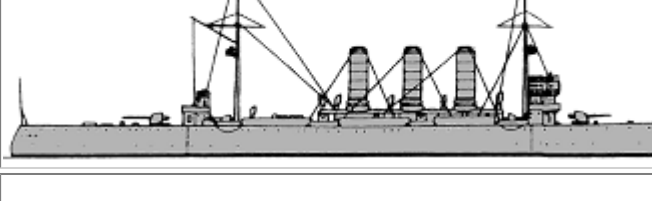

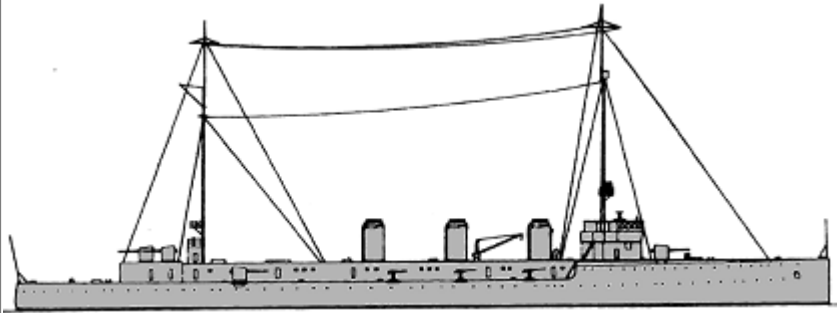
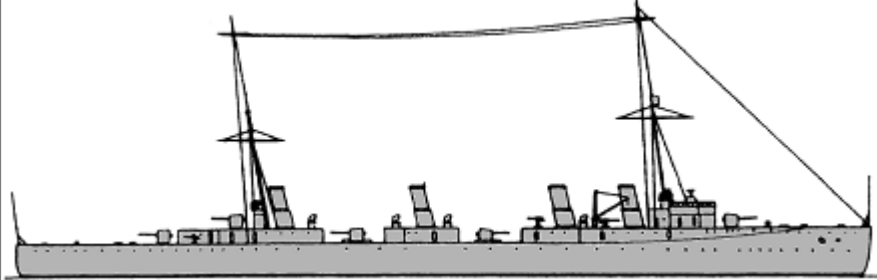
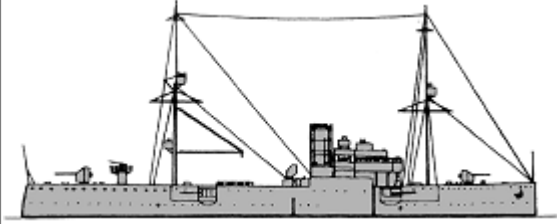



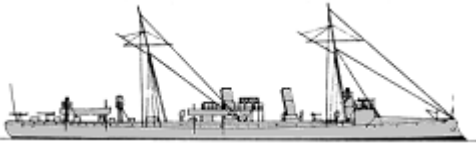
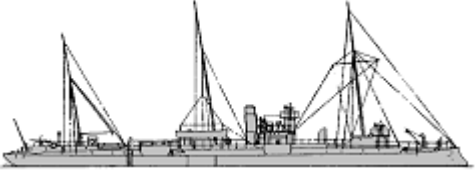
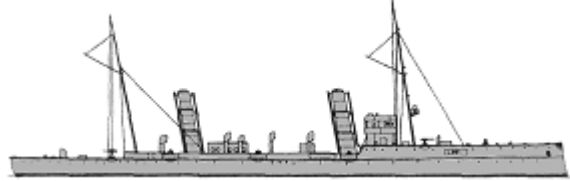





CL	Flavio Gioia	1	1	Flavio Gioia	1883		3064t, 84.5x12.8x5.2m, 8b,1hr, 4156hp, 14kts, 268p; steel, deck; 4x1-76/40
	Amerigo Vespucci	1	2	Amerigo Vespucci	1884		2751t, 84.5x12.8x5.5m, 8b,1hr, 3000hp, 13kts, 268p; 4x1-176/40
	Etna	1	3	Etna	1887		3737-3888t, 91.4x13.2x5.8m, 4b,2vde, 6252-7480hp, 16.6-18kts, 308p; compound, 38deck, 13CT; 4x1-152/40(5), 8x1-152/40(6), 2x1-120/40(5), 2x1-76/40(5), 1x1-75/21, 4x1-57/40(5), 5x1-57/40(6), 2x1-47/40(5), 2x1-37/25(5), (1x5+6x1)-37/20(6), 1x1-11.4/94(5), 3x1-11.4/94(6), 2-350TT
	Piemonte	1	4	Piemonte	1889		2597t, 97.8x11.6x4.9m, 4b,2vte, 7100hp, 20.4kts, 298p; compound, 76deck, 114shields, 76CT; 10x1-120/40, 6x1-57/40, 4x1-37/20, 4x1-11.4/94, 2-350TT
	Umbria	5	Lombardia	1893		2411-2750(5,6,8)-2950(7)t, 84.8(5,6)-88.2(7)-88.3(8)x12.0(5,6)-12.7(7)-12.0(8)x4.7-5.5m, 4b,2hte(5-7)-4b,2vte(8), 6842-7677hp, 17-19.8kts, 213-278p; Harvey, 50(5-7)-25(8)deck, 50CT; 2x1-152/40(9), 6x1-120/40(5-7), 7x1-76/40(8), 8x1-57/40(5), 1x1-40/39(8), 2x1-37/25(5-7), 1x1-37/43(8), 2-450TT(5-7), 3seaplanes(7), mines(6,8)	
		6	Liguria	1894			
		7	Elba	1896			
		8	Puglia	1901			
	Calabria	1	9	Calabria	1897		2660t, 81.0x12.7x5.1m, 4b,2vte, 4260hp, 16.4kts, 254p; 50deck, 50CT; 6x1-120/40, 6x1-57/40, 2x1-37/25, 2-450TT
	Libia	1	10	Libia	1913		4466t, 111.8x14.5x5.5m, 16b,2vte, 11530hp, 22.9kts, 314p; 100deck, 76shields, 100CT; 2x1-152/50, 8x1-120/45, 3x1-76/40, 8x1-47/50, 6x1-37/25, 2-450TT



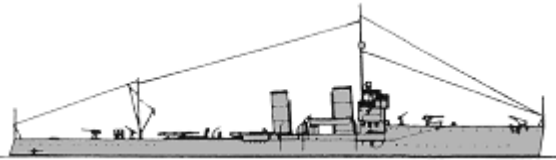

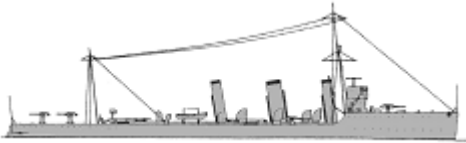

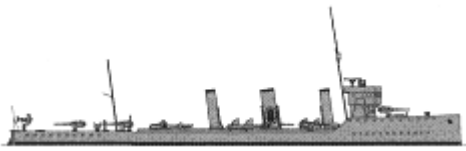

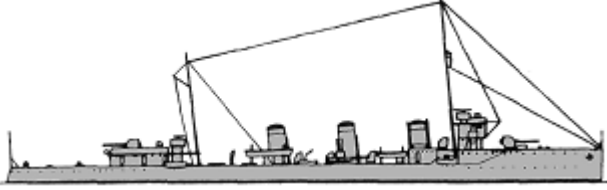
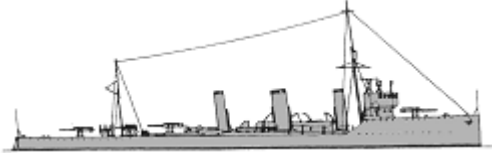

Quarto	1	11	Quarto	1913		3442t, 131.6x12.8x4.1m, 10b, 4st, 25000hp, 28kts, 247p; 40deck, 100CT; 6x1-152/50, 6x1-76/50, 2-450TT, 200mines
Nino Bixio	2	12	Nino Bixio	1914		4141t, 140.3x13.0x4.1m, 14b,3st, 22500hp, 26.8-27.5kts, 296p; 40deck, 100CT; 6x1-120/50, 6x1-76/50, 2-450TT, 200mines
		13	Marsala	1914		
Campania	1	14	Campania	1917		3187t, 83.0x12.7x5.2m, 4b,2vte, 5000hp, 15.7kts, 204p; 25deck, 50CT; 6x1-152/40, 5x1-76/40, 2x1-47/50



## TORPEDO SHIPS

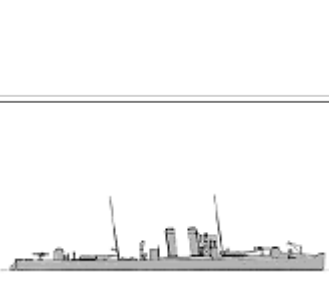

PGT	Tripoli	1	1	Tripoli	1886		952t, 73.4x7.9x3.7m, 6b,3de, 2500hp, 17.5kts, 111p; steel, 40deck; 2x1-76/40, 4x1-57/40, 64mines
	Goito	2	2	Goito	1888		955-974t, 73.4x7.9-8.0x3.0-3.6m, 6b,2vde(2)-6b,3vte(3), 2500(2)-3180(3)hp, 18(3)-17(2)kts, 121p; steel, 40deck; 6x1-57/40(3), 5x1-57/40(2), (3x5+2x1)-37/20(2), 2x1-37/20(3), 4-350TT(3), 60mines(2)
			3	Montebello	1889		
	Partenope	2	4	Minerva	1892		821-931t, 73.1x8.2x3.5m, 4b,2vte, 3884-4422hp, 18.1-20.8kts, 121p; 1x1-120/40(5), 2x1-76/40(4), 6x1-57/43(5), 4x1-57/43(4), 3x1-37/20(5), 2x1-37/20(4), (2+4x1)-450TT(5), 20mines(4)
			5	Iride	1892		
	Agordat	2	6	Agordat	1900		1340-1292t, 91.6x9.3x3.6m, 8b,2vte, 7500(7)-8000(8)hp, 22(7)-22.5(8)kts, 185p; steel, 20deck; 2x1-120/40(7), 12x1-76/40(6), 4x1-76/40(7), 2x1-450TT(6), mines(7)
7			Coatit	1900			
Fulmine	1	1	Fulmine	1900		337t, 62.2x6.4x2.3m, 4b,2vte, 4729hp, 24kts, 48p; 1x1-76/40, 3x1-57/43, 2x1-350TT	

						
Lampo	5	2	Lampo	1900		348t, 62.1x6.5x2.6m, 4b,2vte, 5230-5998hp, 30kts, 61p; 1x1-76/40(2,3,5), 5x1-57/43(2,3,5), 6x1-57/43(4,6), 2x1-350TT, 12mines
		3	Dardo	1901		
		4	Strale	1901		
		5	Euro	1901		
		6	Ostro	1901		
Nembo	3	7	Aquilone	1903		380t, 64.0x5.9x2.3m, 3b,2vte, 5200-5350hp, 30kts, 58p; 4x1-76/40, 2x1-450TT, 16mines
		8	Zeffiro	1905		
		9	Espero	1905		
Artigliere	5	10	Artigliere	1907		412t, 65.0x6.1x2.1m, 3b,2vte, 6000hp, 28.5kts, 55p; 4x1-76/40, 3x1-450TT, 10mines
		11	Bersagliere	1907		
		12	Granatiere	1907		
		13	Lanciere	1907		
		14	Corazziere	1910		
Alpino	3	15	Alpino	1910		424t, 65.0x6.1x2.1m, 3b,2vte, 6000hp, 28.5kts, 50p; 4x1-76/40, 3x1-450TT, 10mines
		16	Fuciliere	1910		
		17	Pontiere	1910		
Ascaro	1	18	Ascaro	1913		414t, 65.0x6.1x2.1m, 3b,2vte, 6000hp, 28.5kts, 55p; 4x1-76/40, 3x1-450TT, 10mines
Indomito	4	19	Indomito	1913		900t, 73.0x7.3x2.4m, 4b,2st, 16000hp, 28kts, 79p; 5x1-102/35, 1x1-40/39, 2x2-450TT, 10mines
		20	Impavido	1913		
		21	Insidioso	1914		
		22	Irrequieto	1913		
Ardito	2	23	Ardito	1913		900t, 73.0x7.3x2.4m, 4b,2st, 16000hp, 28kts, 69p; 5x1-102/35, 1x1-40/39, 2x2-450TT, 10mines
		24	Ardente	1914		
Audace	1	25	Animoso	1914		840t, 75.5x7.5x2.6m, 4b,2st, 16000hp, 30kts, 79p; 5x1-102/35, 2x1-40/39, 2x1-450TT, 10mines
Alessandro Poerio	2	26	Alessandro Poerio	1915		1216t, 85.0x8.0x3.1m, 3b,2st, 20000hp, 31.5kts, 129p; 5x1-102/45(26), 6x1-102/45(27), 2x1-40/39, 2x2-450TT, 42mines
		27	Guglielmo Pepe	1915		
		28	Rosolino Pilo	1915		
		29	Giuseppe Cesare Abba	1915		



Rosolino Pilo	8	30	Pilade Bronzetti	1916		912t, 73.0x7.3x2.7m, 4b,2st, 16000(28-31,33,35)-14800(32,34)hp, 30(28-31,33,35)-29(32,34)kts, 79p; 6x1-76/40, 4x1-450TT, 10mines
		31	Giuseppe Missori	1916		
		32	Antonio Mosto	1915		
		33	Ippolito Nievo	1915		
		34	Francesco Nullo	1915		
		35	Simone Schiaffino	1915		
Carlo Mirabello	3	36	Carlo Mirabello	1916		1972t, 103.4x9.7x3.6m, 4b,2st, 44000hp, 35kts, 169p; 8x1-102/35, 2x1-76/40, 2x2-450TT, 100mines(36,37), 120mines(38)
		37	Carlo Alberto Racchia	1916		
		38	Augusto Riboty	1917		
Giuseppe Sirtori	4	39	Giuseppe Sirtori	1916		850t, 73.5x7.3x2.8m, 4b,2st, 15500hp, 30kts, 85p; 6x1-102/35, 2x1-40/39, 2x2-450TT, 10mines
		40	Giovanni Acerbi	1917		
		41	Vincenzo Giordano Orsini	1917		
		42	Francesco Stocco	1917		
Audace	1	43	Audace	1917		1170t, 87.5x8.3x2.9m, 3b,2st, 22000hp, 30kts, 118p; 7x1-102/35, 2x1-40/39, 2x2-450TT
Aquila	3	44	Aquila	1917		1733(44)-1760(45,46)t, 94.7x9.5x3.6m, 5b,2st, 40000hp, 34kts, 146p; (2x2+1x1)-120/45, 2x1-76/40, 2x2-450TT, 44mines(44,46), 24mines(45)
		45	Nibbio	1918		
		46	Sparviero	1917		
Giuseppe La Masa	7	47	Giuseppe La Masa	1919		851t, 73.5x7.3x2.8m, 4b,2st, 15500hp, 30kts, 78p; 4x1-102/45, 2x1-76/40, 2x2-450TT, 10mines
		48	Angelo Bassini	1918		
		49	Agostino Bertani	1919		
		50	Giacinto Carini	1917		
		51	Nicola Fabrizzi	1918		
		52	Giuseppe La Farina	1919		
		53	Giacomo Medici	1918		







72S	3	1-3	105S, 115S, 128S	1890 - 1895		78t, 39.8x4.8x2.0m, 1b,1vde, 902-1080hp, 21-22kts, 17p; 2x1-37/25(1,3), (1+1x1)-350TT(2,3), sweeps(1)
60S	3	4-6	113S, 114S, 134S	1890 - 1894		78t, 39.8x4.8x2.0m, 1b,1st(4)-1b,1vde(5,6), 683-1082hp, 21-22kts, 17p; 2x1-37/25, (1+1x1)-350TT
Condore	1	7	Condore	1900		138t, 48.0x5.6x1.4m, 2b,2vte, 2370hp, 26kts, 31p; 2x1-37/25, 2x1-350TT
Pellicano	1	8	Pellicano	1900		181t, 48.7x5.7x1.5m, 3b,2vte, 2740hp, 21kts, 30p; 2x1-37/25, 2x1-350TT
Sirio	4	9	Sirio	1905		207t, 51.1x6.0x1.6m, 2b,2vte, 3100hp, 25.5kts, 38p; 2x1-76/30, 3x1-450TT
		10	Sagittario	1905		
		11	Spica	1905		
		12	Saffo	1906		
Pegaso	3	13	Pegaso	1905		207t, 50.4x5.3x1.7m, 2b,2vte, 2900-3279hp, 25-26.6kts, 42p; 2x1-76/40, 1x1-13.2/76, 2x1-450TT
		14	Procione	1906		
		15	Pallade	1906		
Cigno	8	16	Calipso	1909		208-217t, 50.3x5.3x1.7m, 2b,2vte, 2900hp, 25kts, 38p; 2x1-76/40, 1x1-13.2/76, 4x1-450TT
		17	Calliope	1906		
		18	Canopo	1907		
		19	Cassiopea	1906		
		20	Centauro	1907		
		21	Cigno	1906		
		22	Climene	1909		
		23	Clio	1907		
Alcione	6	24	Airone	1907		217t, 50.3x5.3x1.7m, 2b,2vte, 2900hp, 25kts, 38p; 1x1-76/40, 1x1-76/30(25,27,29), 1x1-13.2/76, 2x1-450TT, sweeps(24,26,28)
		25	Albatros	1907		
		26	Alcione	1907		
		27	Ardea	1907		
		28	Arpia	1908		
		29	Astore	1908		
Orione	4	30	Olimpia	1907		220t, 52.6x6.0x1.5m, 2b,2vte, 2900hp, 25kts, 38p; 2x1-76/30, 1x1-13.2/76, 2x1-450TT
		31	Orfeo	1907		
		32	Orione	1907		
		33	Orsa	1907		
Gabbiano	1	34	Gabbiano	1907		174t, 49.6x5.9x1.7m, 2b,2vc, 2200hp, 22kts, 32p; 2x1-47/40, 3x1-350TT, 14mines
		35	1PN	1911		
		36	2PN	1911		
		37	3PN	1911		
		38	4PN	1911		

TB	1PN	35	39	6PN	1912		134-143t, 42.5x4.6x1.4-1.5m, 2b,2vte(35-62,65-69)-2b,3st(63)-2b,2st(64), 3200hp, 27kts, 30p; 1x1-76/40, 1x1-76/30, 2x1-450TT, 10mines					
			40	7PN	1912							
			41	8PN	1912							
			42	9PN	1912							
			43	10PN	1912							
			44	11PN	1913							
			45	12PN	1913							
			46	13OS	1912							
			47	14OS	1912							
			48	15OS	1912							
			49	16OS	1912							
			50	18OS	1912							
			51	19OS	1912							
			52	20OS	1913							
			53	21OS	1913							
			54	22OS	1912							
			55	23OS	1913							
			56	24OS	1913							
			57	25AS	1912							
			58	26AS	1913							
			59	27AS	1913							
			60	28AS	1913							
			61	29AS	1913							
			62	30AS	1913							
			63	31AS	1915							
			64	32AS	1914							
			65	33PN	1913							
			66	34PN	1913							
			67	35PN	1913							
			68	37PN	1913							
			69	38PN	1913							
				39RM	1			70	39RM	1916		158t, 42.5x4.6x1.6m, 2b,2vde+1st(3), 2700hp, 27kts, 30p; 1x1-76/40, 2x1-450TT
								71	40PN	1916		
								72	41PN	1916		
								73	42PN	1916		
			74	43PN	1916							
			75	44PN	1916							
			76	45PN	1916							
			77	46OS	1916							
			78	47OS	1916							

40PN	30	79	48OS	1916		168t, 42.5x4.6x1.6m, 2b,2vte, 2700hp, 27kts, 30p; 2x1-76/30, 1x1-37/43(77-83,85,89-91), 1x2-450TT, 10mines
		80	49OS	1916		
		81	50OS	1916		
		82	51OS	1916		
		83	52AS	1916		
		84	53AS	1916		
		85	54AS	1916		
		86	55AS	1916		
		87	56AS	1916		
		88	57AS	1916		
		89	58OL	1916		
		90	59OL	1916		
		91	60OL	1916		
		92	61OL	1916		
		93	62OL	1916		
		94	63OL	1916		
		95	64PN	1917		
		96	65PN	1918		
		97	66PN	1918		
		98	67PN	1918		
99	68PN	1918				
100	69PN	1918				
Francesco Rismondo	1	101	Francesco Rismondo	1910		132t, 44.2x4.3x1.5m, 2b,2vte, 2400hp, 26.5kts, 20p; 2x1-47/40, 2x1-450TT
70OLT	2	102	74OLT	1918		195t, 45.7x4.6x1.8m, 2b,2st, 3500hp, 27kts, 31p; 2x1-76/30, 1x2-450TT, 7mines
		103	75OLT	1918		

### SUBMARINES

Argonauta	1	1	Argonauta	1915		255/306t, 45.2x4.2x3.1m, 2d/em, 700/450hp, 13.5/8.8kts, 24p, 40m; 1x1-76/30, 2-450TT
Pacinotti	1	2	Pacinotti	1916		710/869t, 65.0x6.1x4.1m, 2d/em, 1100/900hp, 12/8.5kts, 39p, 35m; 2x1-76/30, 5-450TT
		3	F1	1916		
		4	F2	1916		
		5	F5	1916		
		6	F6	1917		
		7	F7	1917		
		8	F9	1916		

SS	F1	17	9	F10	1916		262/319t, 45.6x4.2x3.1m, 2d/em, 670/500hp, 12.5/8.2kts, 26p, 40m; 1x1-76/30, 2-450TT
			10	F12	1917		
			11	F13	1917		
			12	F14	1917		
			13	F15	1917		
			14	F16	1917		
			15	F17	1917		
			16	F18	1917		
			17	F19	1918		
			18	F20	1918		
	19	F21	1918				
	H1	7	20	H1	1916		364/475t, 45.8x4.7x3.8m, 2d/em, 480/620hp, 12/11kts, 22p, 50m; 4-450TT
			21	H2	1916		
			22	H3	1917		
			23	H4	1917		
			24	H6	1917		
			25	H7	1917		
			26	H8	1918		
	Pietro Micca	5	27	Pietro Micca	1918		842/1244t, 63.2x6.2x4.3m, 2d/em, 2600-2900/1300-1800hp, 11/10.9kts, 40p, 50m; 1x1-76/40, 1x1-76/30, 6-450TT
28			Angelo Emo	1919			
29			Luigi Galvani	1918			
30			Lorenzo Marcello	1919			
31			Torricelli	1918			
Andrea Provana	4	32	Andrea Provana	1918		762/924t, 67.0x5.9x3.8m, 2d/em, 2600/1400hp, 16/9.8kts, 40p, 50m; 2x1-76/40, 6-450TT	
		33	Agostino Barbarigo	1918			
		34	Giacomo Nani	1919			
		35	Sebastiano Veniero	1919			
N1	6	36	N1	1918		277/363t, 45.8x4.3x3.2m, 2d/em, 650(36-39)-820(40,41)/400(36-39)-450(40,41)hp, 12.5(36-39)-13.5(40,41)/7.6(36-39)-7.9(40,41)kts, 23p, 40m; 1x1-76/30, 2-450TT	
		37	N2	1918			
		38	N3	1918			
		39	N4	1919			
		40	N5	1919			
		41	N6	1919			
X2	2	42	X2	1918		403/468t, 42.6x5.5x3.2m, 2d/em, 650/325hp, 8.2/6.3kts, 25p, 40m; 1x1-76/30, 18mines	
		43	X3	1918			

## ESCORTS



AY	-	6	1	Giuliana	1893	1050t, 76.2x8.5x3.9m, 1vte, 700hp, 11.9kts; 2x1-76/40
			2	Archimede	1892	900t; 4x1-57/43
			3	Capitano Verri	1887	705t; 3x1-102/40
			4	Cunfida	1892	560t; 2x1-76/40
			5	Misurata	1894	880t; 2x1-76/40
			6	Tobruk	1897	850t; 3x1-76/40
			1	G1	1912	425t; 2x1-76/40
			2	G3	1912	370t
			3	G8	1911	440t; 2x1-76/40
			4	G9	1912	356t; 1x1-76/40
			5	G10	1911	380t; 1x1-76/40
			6	G13	1912	500t; 2x1-76/40
			7	G15	1912	380t; 2x1-76/40
			8	G16	1912	420t; 2x1-76/40
			9	G17	1911	380t; 2x1-76/40
			10	G18	1913	335t; 2x1-76/40
			11	G21	1912	440t; 2x1-76/40
			12	G22	1912	440t; 2x1-76/40
			13	G23	1912	430t; 1x1-76/40
			14	G24	1911	385t; 2x1-76/40
			15	G26	1911	402t; 2x1-76/40
			16	G27	1911	500t; 2x1-76/40
			17	G28	1911	400t; 2x1-76/40
			18	G29	1911	420t; 2x1-76/40
			19	G30	1911	394t; 2x1-76/40
			20	G31	1911	400t; 2x1-76/40
			21	G33	1911	410t; 2x1-76/40
			22	G34	1911	370t; 2x1-76/40
			23	G36	1911	385t; 2x1-76/40
			24	G37	1911	390t; 2x1-76/30
			25	G38	1909	452t; 2x1-76/40
			26	G40	1912	395t; 2x1-76/40
			27	G41	1911	388t; 2x1-76/40
			28	G44	1910	396t; 2x1-76/40
			29	G47	1911	465t; 2x1-76/40
			30	Aliseo		215t
			31	Valoroso	1913	420t; 2x1-76/40
			32	Balena	1911	286t; 1x1-76/40
			33	Basiluzzo	1915	110t
			34	Bufera		1x1-76/40

APC

- 76

35	Burrasca	1912	280t; 1x1-76/40
36	Capodoglio		
37	Ciclone		170t
38	Cicogna		
39	Cuma		
40	Favignana	1898	170t
41	Flutto		1x1-76/40
42	Folaga		
43	Gaeta	1916	250t; 1x1-76/40
44	Lampedusa	1915	166t; 1x1-76/40
45	Lavezzi	1912	168t
46	Voragine		1x1-76/40
47	Lido	1908	279t; 1x1-76/40
48	Lilibeo	1915	124t
49	Liscanera	1916	222t; 1x1-76/40
50	Mestrale	1912	200t
51	Marmarica		310t; 1x1-76/40
52	Maroso	1896	225t
53	Monzone		
54	Montecristo	1876	429t
55	Ogliastra	1892	
56	Panaria	1904	355t; 2x1-76/40
57	Vortice		1x1-76/40
58	Pelago	1914	322t; 2x1-76/40
59	Porto d'Anzio	1914	166t; 1x1-76/40
60	Porto Ercole	1914	140t; 1x1-76/40
61	Portofino	1915	270t; 1x1-76/40
62	Procella		
63	Razzoli		
64	Selinunte		
65	Scolta	1913	424t; 2x1-76/40
66	Serpentara		
67	Sirena		
68	Spartivento		
69	Talamone	1916	190t; 1x1-76/40
70	Tempesta	1883	161t
71	Terracina	1916	230t; 1x1-76/40
72	Tifone		
73	Vigilante	1906	316t; 1x1-76/40
74	Tuono		
75	Vortice		





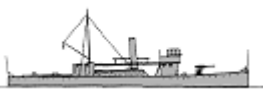
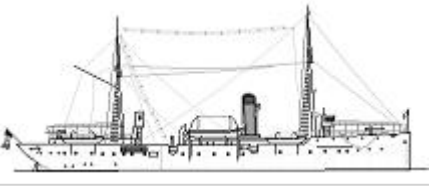







			76	Zannone			
ADV	-	2	1	Gianicolo	1908		262t
			2	Malamocco			300t

## OTHER FIGHTING SHIPS

PG	Brondolo	2	1	Brondolo	1909		117t, 38.1x6.3x0.8m, 1b,2vte, 500hp, 13kts, 18p; 1x1-76/40, mines
			2	Marghera	1909		
PG	Sebastiano Caboto	1	3	Sebastiano Caboto	1912		1050t, 63.4x9.7x3.0m, 2b,2vte, 1203hp, 13.2kts, 107p; 6x1-76/40
PR	Ape	2	1,2	Ape, Vespa	1918	No picture	50t, 20.5ppx3.4x0.9m, 2pe, 120hp, 9.4kts; 1x1-75/17
APG	-	7	1	Abisso	1912		400t; 2x1-76/40
			2	Generale Arimondi	1910		580t; 1x1-76/40
			3	Boeo	1916		235t; 1x1-76/40
			4	Cirenaica	1885		305t; 2x1-76/40
			5	Linosa	1898		388t; 2x1-76/40
			6	Palmaiola	1902		562t; 1x1-76/40
			7	Scaparro	1916		160t; 2x1-127/51

## COASTAL FORCES



MTB	MAS1	2	1,2	MAS1,2	1916		13t, 16.0x2.6x1.0m, 2pe/em, 450/10hp, 23/4kts, 8p; 1x1-47/40(1), 2-450TT, 4mines(1), 4dc(2)
	MAS3	15	3-17	MAS4-6, 8, 9, 11-13, 15, 17-22	1916-1917		16t, 16.0x2.6x1.2m, 2pe(3-6,8,12,14)-2pe/em(7,9-11,13,15-17), 450(3-6,8,12,14)-450/10(7,9-11,13,15-17)hp, 22.3-25.2(3-6,8,12,14)-22.3-25.2/4(7,9-11,13,15-17)kts, 8p; 2-450TT or 1x1-47/40, 6dc
	MAS91	11	18-28	MAS91, 92, 94-102	1917-1918		12-13t, 16.2x2.8x1.3-1.4m, 2pe(18,23-25)-2pe/em(19-22,26-28), 450(18)-500/10(19-22,26-28)-500(23-25)hp, 29.5(18,23-25)-29.5/4(19-22,26-28)kts, 8p; 1x1-47/40 or 2-450TT, 4dc
	MAS158	45	29-73	MAS158-165, 167-202	1918-1919		12t, 16.0x2.6x1.1m, 2pe, 400-480hp, 23-26.5kts, 8p; 1x1-57/43(32-35,39-73), 2-450TT(29-31,36-38), 6dc
	MAS203	1	74	MAS203	1917		13t, 16.0x2.6x0.9m, 2pe/em, 460/10hp, 26/4kts, 8p; 1x1-47/40 or 2-450TT, 10dc
	MAS204	14	75-88	MAS204-217	1918		14t, 16.0x2.6x1.1m, 2pe/em(75-87)-2pe(88), 480/10(75-87)-480(88)hp, 23-24/4(75-87)-23-24(88)kts, 7p; 1x1-57/43 or 2-450TT, 10dc
	MAS218	15	89-103	MAS218-232	1918-1919		13t, 16.4x2.9x1.4m, 2pe/em(89-93,99)-2pe(94-98,100-103), 500/10(89-93,99)-500(94-98,100-103)hp, 26/4(89-93,99)-26(94-98,100-103)kts, 8p; 1x1-57/43 or 2-450TT, 4dc
	MAS325	2	104,105	MAS325, 326	1918		14t, 16.0x2.9x1.2m, 2pe, 440hp, 23kts, 8p; 1x1-57/43 or 2-450TT, 4dc
	MAS319	5	106-110	MAS319-323	1919		14t, 16.0x2.9x1.2m, 2pe, 700hp, 28kts, 8p; 2-450TT, 4dc
	Grillo	1	111	Locusta	1918		8t, 16.0x3.1x0.7m, 1pe(+tracks), 10hp, 4kts, 4p; 2-450TT
MAS411	4	112-115	MAS411-414	1919		23t, 18.0x3.6x1.2m, 2pe/em, 1600/16hp, 25/5kts, 10p; 2-450TT, 4dc	

	MAS551	1	116	MAS551	1919	No picture	19t
MGB	MAS23	27	1-27	MAS23, 24, 26, 27, 29-48, 50-52	1916-1917		12t, 16.0x2.6x1.3m, 2pe, 400hp, 18-22kts, 8p; 1x1-47/40, 4dc
	MAS53	5	28-32	MAS53-57	1917		11t, 16.0x2.6x1.2m, 2pe, 400-450hp, 23.2-24kts, 8p; 1x1-47/40(29-32), 2-450TT(28), 6dc
	MAS58	5	33-37	MAS58-62	1917		12t, 16.0x3.0x1.2m, 3pe(33)-2pe(34-37), 600(33)-400(34-37)hp, 25(33)-22-23(34-37)kts, 8p; 1x1-47/40, 6dc
	MAS318	1	38	MAS318	1917		20t, 17.5x3.2x1.2m, 2pe, 500hp, 20kts, 10p; 1x1-57/43, 20dc
	MAS115	23	39-61	MAS115-124, 126-134, 136-139	1918		19t, 18.0x3.2x1.2m, 2pe, 500hp, 21-23kts, 12p; 1x1-76/30, 20dc
	MAS140	16	62-77	MAS141-143, 145-157	1918-1919		12t, 16.0x2.6x1.1m, 2pe, 400-480hp, 24-25kts, 8p; 1x1-57/43, 6dc
	MAS233	19	78-96	MAS233-239, 241-252	1918-1919		19t, 18.0x3.3x1.2m, 2pe, 500hp, 20kts, 12p; 1x1-76/40, 20dc
MAS	MAS63	26	1-26	MAS63-78, 80-87, 89, 90	1917-1918		44t, 24.4x3.7x1.2m, 2pe, 460hp, 15-17kts, 15p; 1x1-76/40, 10dc
	MAS103	10	27-36	MAS103, 105-107, 109-114	1918		44t, 24.4x3.7x1.2m, 2pe, 460hp, 15-17kts, 15p; 1x1-76/30, 10dc
	MAS253	47	37-83	MAS253, 255-263, 265-292, 294-302	1918		44t, 24.4x3.7x1.2m, 2pe, 460hp, 15-17kts, 15p; 1x1-76/40, 10dc
	MAS303	12	84-95	MAS303-307, 309-312, 314-316	1918-1919		45t, 24.4ppx3.8x1.3m, 2pe, 460hp, 18kts, 15p; 1x1-76/40, 10dc
	MAS327	14	96-109	MAS327-334, 346, 372-376	1918-1919		45t, 24.4ppx3.8x1.3m, 2pe, 460hp, 18kts, 15p; 1x1-76/40, 10dc
	MAS377	18	110-127	MAS377, 379-393, 395, 396	1918-1919		44t, 24.4x3.7x1.2m, 2pe, 460hp, 15-17kts, 15p; 1x1-76/40, 10dc

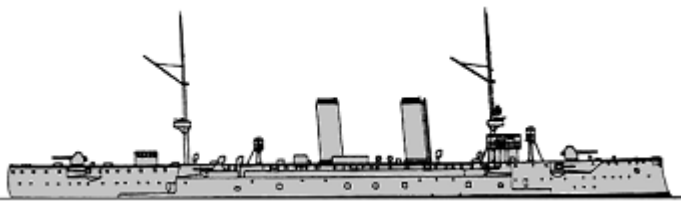
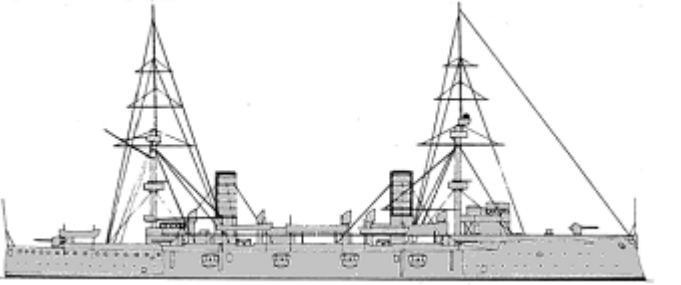
## AMPHIBIOUS SHIPS

	Marco Polo	1	1	Cortellazzo	1894		4820t, 106.1x14.7x5.9m, 4b,2vte, 10663t, 17.8kts, 402p; 100belt, 25deck, 50shields, 50CT; light guns; troops
AP	Vettor Pisani	1	2	Zenson	1898		7057t, 105.7x18.0x7.2m, 8b,2vte, 13219hp, 19.1kts, 486p; Harvey, 150belt, 37deck, 150casemates, 150CT; light guns; troops

## MINE WARFARE SHIPS

ML	Castore	1	1	Castore	1889		522t, 35.1x11.3x2.5m, 2b,1vc, 364hp, 8kts, 49p; 20mines
AML	-	2	1	Betta N.3	1891		580t; mines
			2	Bengasi	1904		3570t, 87.4x11.2m, 1vte, 2026hp, 13.5kts; 2x1-76/40, mines
MS	RD1	35	1	RD1	1916		196-302t, 34.0-38.0x5.8-7.2x1.9-2.5m, 1b,1vte, 590-1150hp, 10-14kts, 22p; 1x1-76/40, sweeps
			2	RD3	1916		
			3	RD4	1917		
			4	RD5	1917		
			5	RD6	1917		
			6	RD7	1917		
			7	RD8	1917		
			8	RD9	1917		
			9	RD11	1917		
			10	RD12	1917		
			11	RD13	1918		
			12	RD15	1917		
			13	RD16	1917		
			14	RD17	1917		
			15	RD18	1917		
			16	RD19	1917		
			17	RD20	1917		
			18	RD21	1918		
			19	RD22	1918		
			20	RD23	1918		
			21	RD24	1918		
			22	RD25	1918		
			23	RD26	1918		
			24	RD27	1918		
			25	RD28	1918		
			26	RD29	1919		
			27	RD30	1919		
			28	RD31	1919		
			29	RD32	1919		
			30	RD33	1919		
			31	RD34	1919		
			32	RD35	1919		
			33	RD36	1919		
			34	RD39	1919		
			35	RD50	1919		

AMS - 1 1 Rondine 1911 400t; 1x1-76/40, sweeps



© Ivan Gogin, 2014

[home](#)[World navies yesterday](#)[1920](#)

# Japan 01 January 1920

## BATTLESHIPS

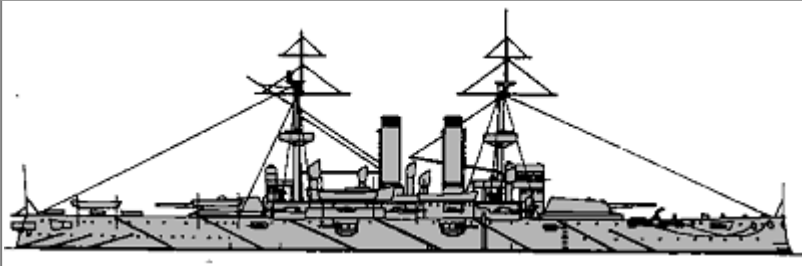
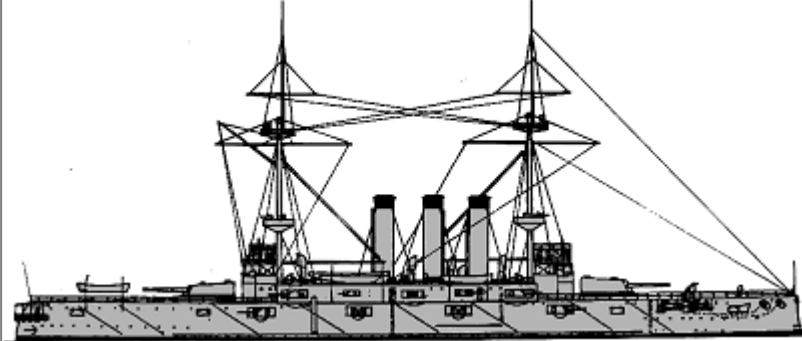
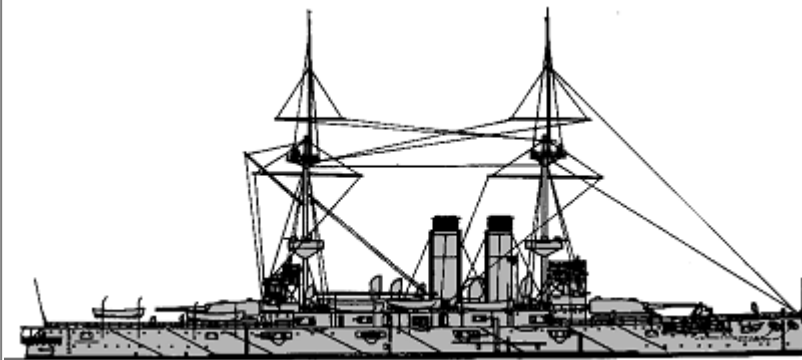
Fuji	1	1	Fuji	1897		12533t, 125.5x22.2x8.1m, 10b,2vte, 14000hp, 18kts, 741p; Harvey- 457belt, 63deck, 152turrets, 356CT; 2x2-305/40, 10x1-152/40, 16x1-76/40, 4x1-47/40, 4x1-47/30, 5-450TT
Shikishima	1	2	Shikishima	1900		15453t, 133.5x23.0x8.3m, 25b,2vte, 14500hp, 18kts, 836p; Harvey- 229belt, 102deck, 254turrets, 356CT; 2x2-305/40, 14x1-152/40, 20x1-76/40, 6x1-47/40, 6x1-47/30, 5-450TT
Asahi	1	3	Asahi	1900		15374t, 129.6x22.9x8.3m, 25b,2vte, 15000hp, 18kts, 830p; Harvey- 229belt, 102deck, 254turrets, 356CT; 2x2-305/40, 14x1-152/40, 20x1-76/40, 6x1-47/40, 6x1-47/30, 4-450TT
Mikasa	1	4	Mikasa	1902		15179t, 131.7x23.2x8.3m, 25b,2vte, 15000hp, 18kts, 830p; Harvey- 229belt, 76deck, 254turrets, 356CT; 2x2-305/45, 14x1-152/45, 20x1-76/40, 8x1-47/40, 4x1-47/30, 4-450TT

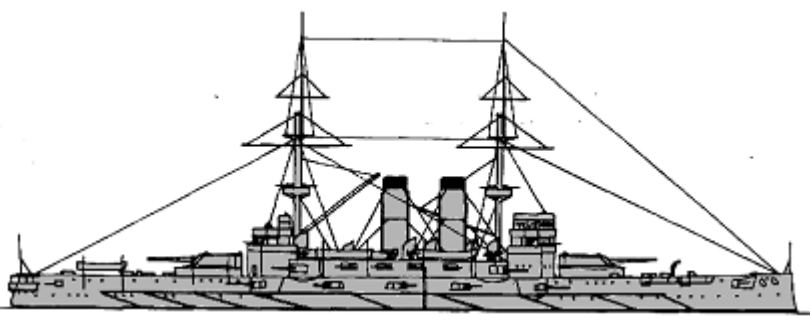
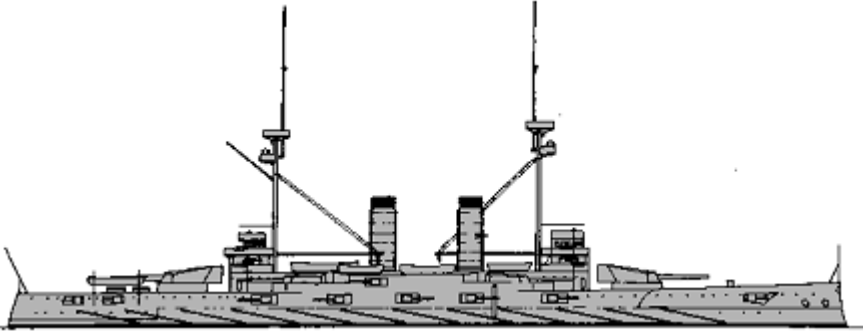
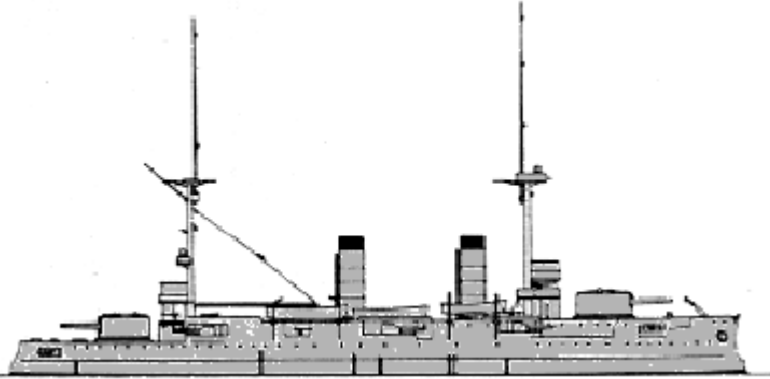
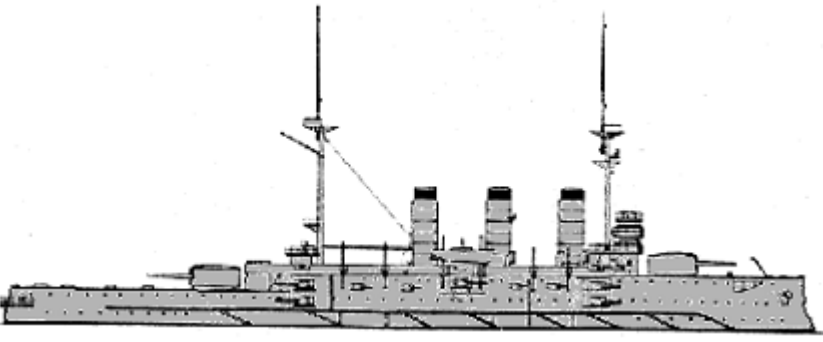
						
BB	Kashima	5	Kashima	1906		17200(5)-16663(6)t, 139.6(5)-139.0(6)x23.8x8.1(5)-8.2(6)m, 20b,2vte, 16600(5)-15800(6)hp, 18.5kts, 864p; 229belt, 51deck, 229turrets, 229CT; 2x2-305/45, 4x1-254/45, 10x1-152/45, 10x1-76/50, 2x1-76/40, 3x1-47/40, 5- 450TT
		2	Katori	1906		
	Iwami	1	Iwami	1904		15300t, 121.0x23.2x8.0m, 20b,2vte, 16300hp, 17.8kts, 806p; 190belt, 75deck, 254turrets, 203CT; 2x2-305/38, 6x1-203/45, 16x1-75/48, 4x1-47/40, 2- 381TT
	Sagami	1	Suwo	1902		13500t, 133.4x21.8x8.0m, 30b,3vte, 15000hp, 18kts, 775p; 229belt, 76deck, 229turrets, 152CT; 2x2- 254/42, 10x1-152/40, 16x1-76/40, 2-381TT
	Hizen	1	Hizen	1901		12902t, 117.9x22.0x7.9m, 24b,2vte, 17000hp, 18kts, 791p; 229belt, 76deck, 229turrets, 254CT; 2x2- 305/38, 12x1-152/43, 14x1-76/40, 2x1-47/40, 2- 450TT

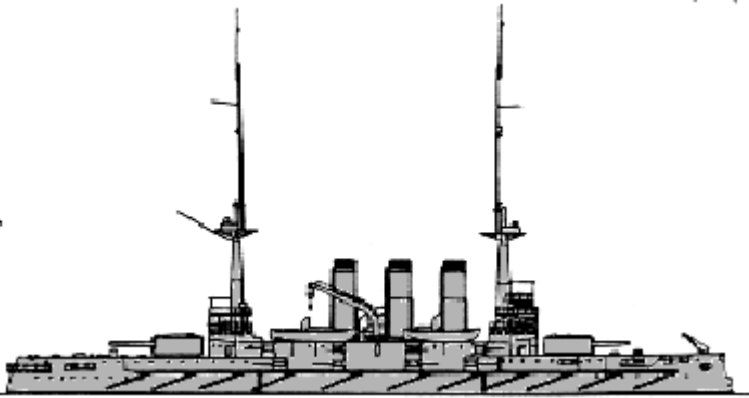
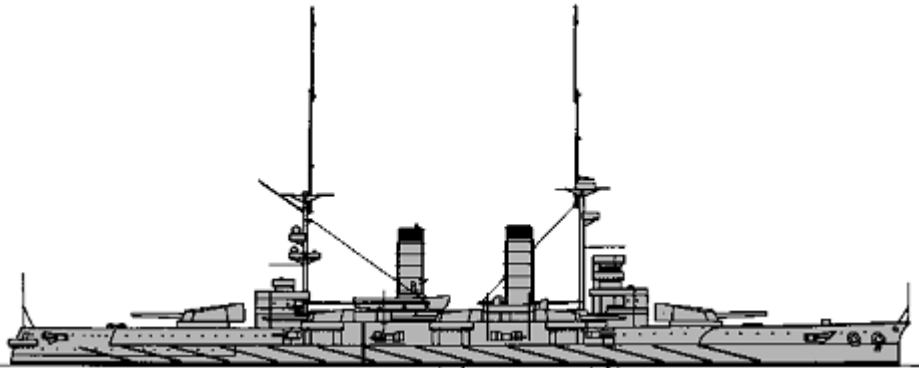
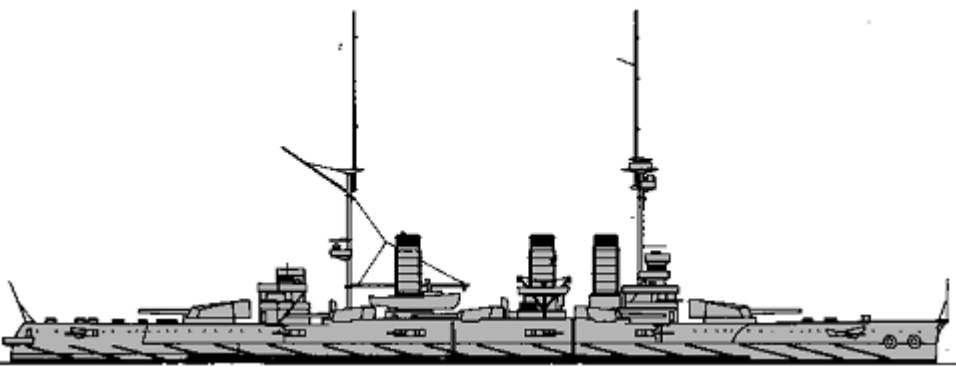
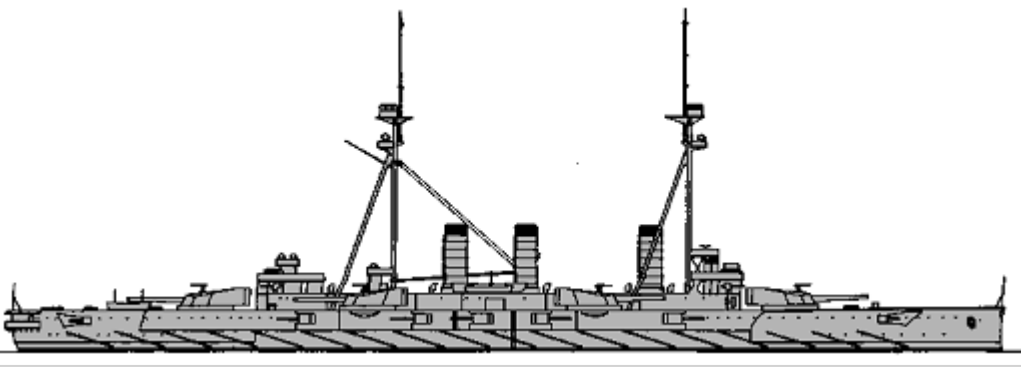

						
Satsuma	1	10	Satsuma	1910		19700t, 146.9x25.4x8.4m, 20b,2vte, 17300hp, 18.3kts, 887p; 229belt, 51deck, 229turrets, 152CT; 2x2-305/45, 6x2-254/45, 12x1-120/40, 6x1-76/40, 4x1-76/23, 5-450TT
Aki	1	11	Aki	1911		21800t, 150.0x25.5x8.4m, 15b,2st, 24000hp, 20kts, 931p; 229belt, 51deck, 203turrets, 152CT; 2x2-305/45, 6x2-254/45, 8x1-152/45, 6x1-76/40, 4x1-76/23, 5-450TT
Settsu	1	12	Settsu	1912		22900t, 160.6x25.7x8.5m, 16b,2st, 25000hp, 20kts, 986p; 305belt, 30deck, 280turrets, 254CT; 2x2-305/50, 4x2-305/45, 10x1-152/45, 8x1-120/40, 4x1-76/40, 3-450TT
		13	Fuso	1915		
Fuso	2					35900(13)-39154(14)t, 205.1x28.7x8.7m, 24b,4st, 40000hp, 22.5kts, 1193p; 305belt, 76deck,

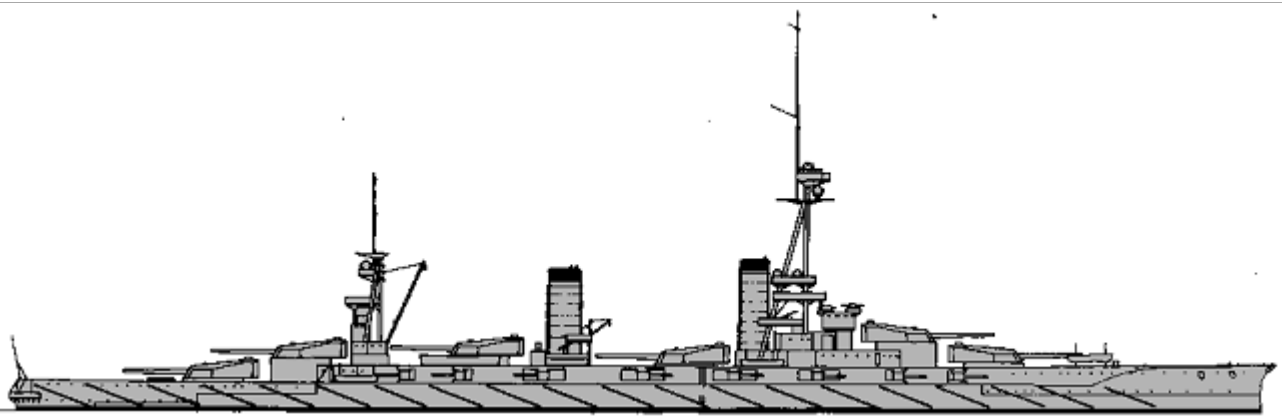
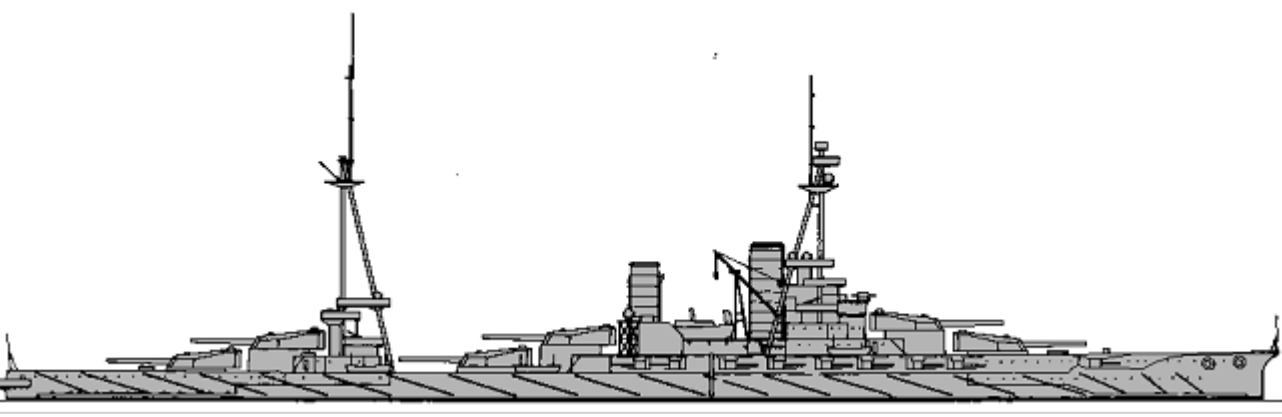
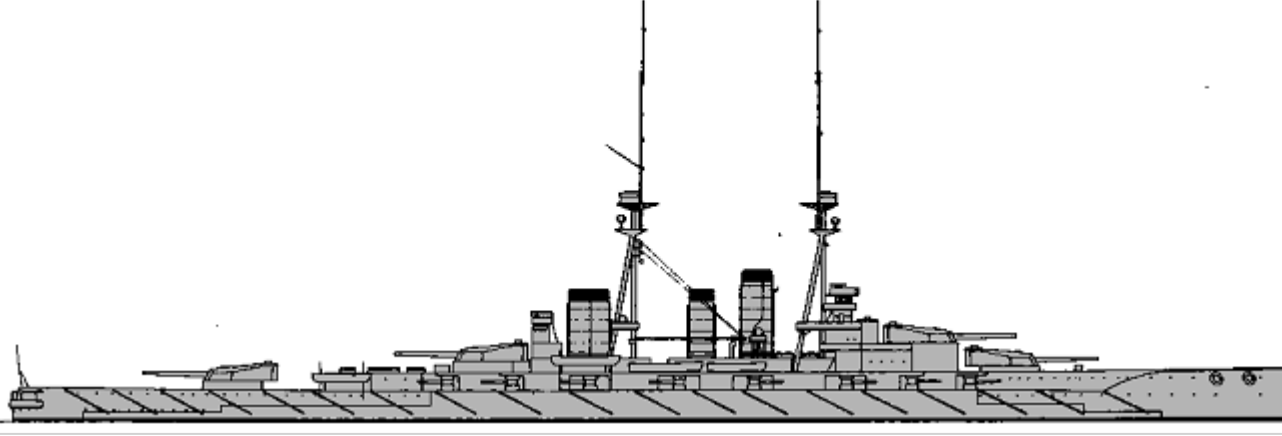
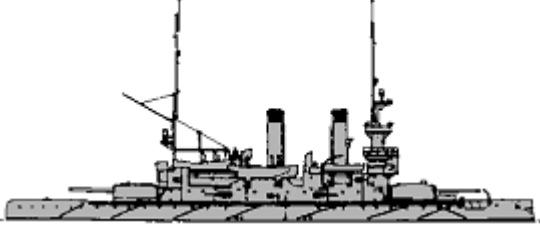
		14	Yamashiro	1917		305turrets, 350CT; 6x2-356/45, 16x1-152/50, 4x1-76/40, 6-533TT
Ise	2	15	Ise	1917		36500t, 208.2x28.7x8.8m, 24b,4st, 45000hp, 23kts, 1360p; 305belt, 51deck, 305turrets, 305CT; 6x2-356/45, 20x1-140/50, 6-533TT
		16	Hyuga	1918		
CB Kongo	4	1	Kongo	1913		32200t, 214.5x28.0x8.4m, 36b,4st, 64000hp, 27.5kts, 1221p; 203belt, 57deck, 229turrets, 254CT; 4x2-356/45, 16x1-152/50, 12x1-76/40(1), 4x1-76/40(2-4), 8-533TT
		2	Hiei	1914		
		3	Kirishima	1915		
		4	Haruna	1915		
BC Mishima	2	1	Mishima	1897		5050t, 86.4x15.9x5.8m, 8b,2vte(1)-18b,2vte(2), 5750hp, 16kts, 404p; Harvey- 254belt, 76deck, 203turrets, 203CT; 2x2-254/42(1), (1x2+1x1)-254/42(2), 6x1-152/40(1), 6x1-120/40(2)
		2	Okinoshima	1899		

AIRCRAFT CARRYING SHIPS

--	--	--	--	--	--	--

AV	-	1	1	Wakamiya	1901		7720t, 111.3ppx14.7x5.8m, 3b,1vte, 1591hp, 10kts, 234p; 2x1-76/40, 2x1-47/40, 4seaplanes (Farman)
----	---	---	---	----------	------	---	---

CRUISERS

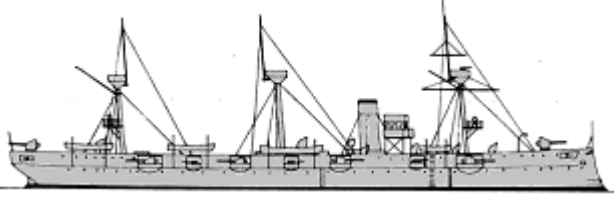
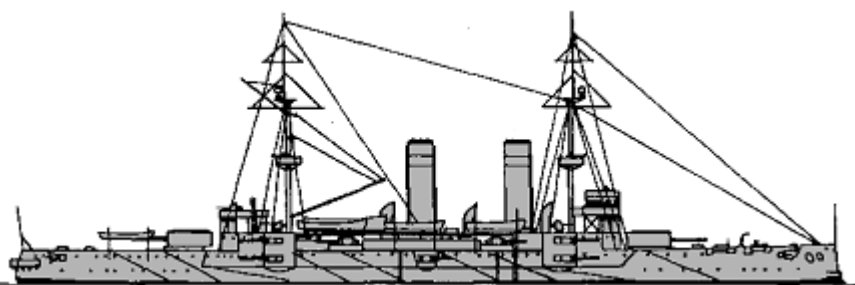
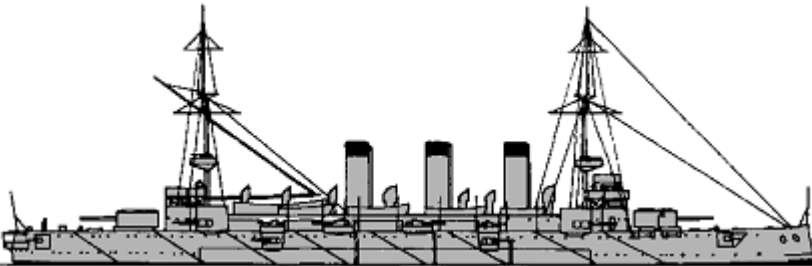
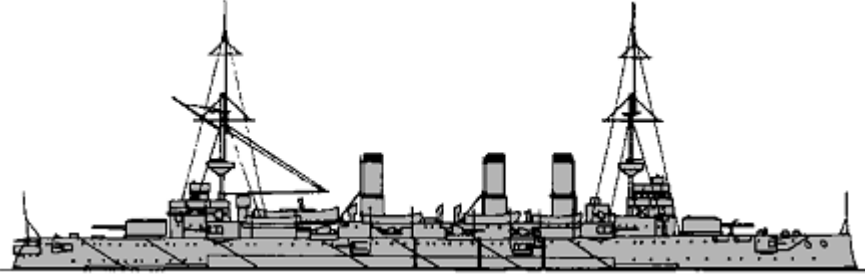
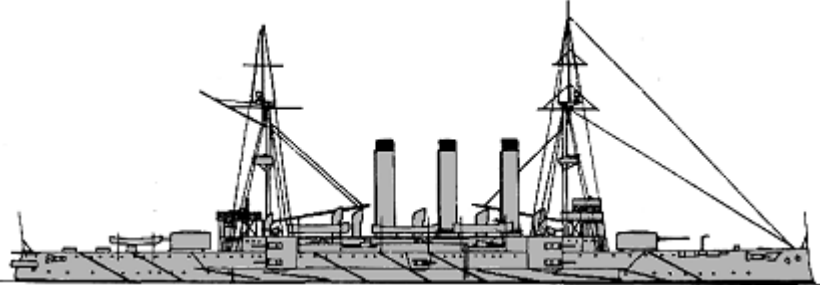
CA		1	1	Chiyoda	1891		2439t, 94.5x12.8x4.3m, 12b,2vte, 5600hp, 19kts, 350p; compound- 92belt, 35deck, 30CT; 10x1-120/40, 14x1-47/40, 3x10-11.4/94, 3-350TT
		2		Asama	1899		10500t, 134.7x20.5x7.4m, 16b,2vte, 18000hp, 21.5kts, 726p; Harvey- 178belt, 76deck, 152turrets, 356CT; 2x2-203/45, 14x1-152/40, 12x1-76/40, 7x1-47/30, 5-450TT
		3		Tokiwa	1899		
		1	4	Yakumo	1900		10300t, 132.3x19.6x7.2m, 24b,2vte, 15500hp, 20.5kts, 700p; 178belt, 63deck, 152turrets, 356CT; 2x2-203/45, 12x1-152/40, 12x1-76/40, 7x1-47/30, 5-450TT
		1	5	Adzuma	1900		9953t, 137.9x20.9x7.2m, 24b,2vte, 17000hp, 20kts, 650p; 178belt, 63deck, 152turrets, 356CT; 2x2-203/45, 12x1-152/40, 12x1-76/40, 12x1-47/40, 5-450TT
		2	6	Idzumo	1900		10300t, 132.3x20.9x7.4m, 24b,2vte, 14500hp, 20.8kts, 672p; 178belt, 63deck, 152turrets, 356CT; 2x2-203/45, 14x1-152/40, 12x1-76/40, 8x1-47/30, 4-450TT
	7		Iwate	1901			

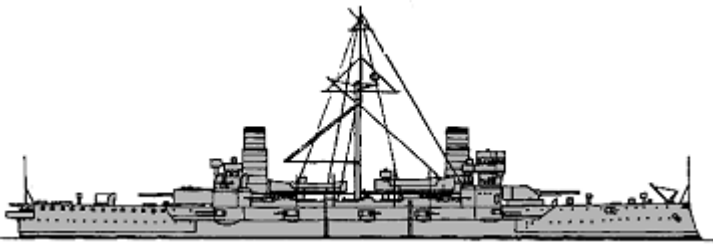
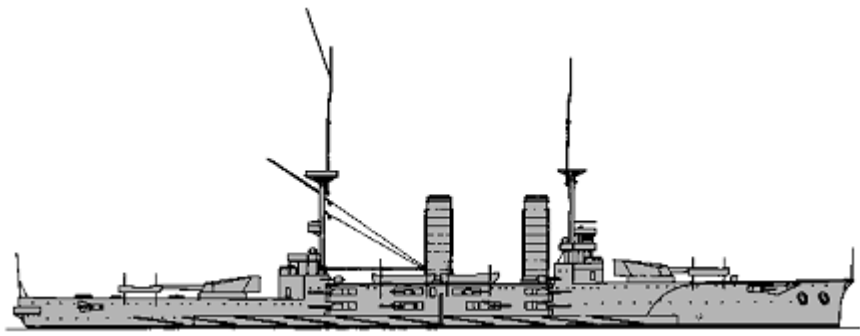
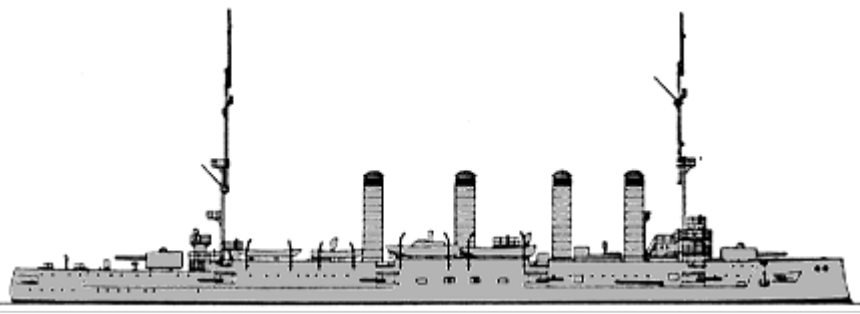
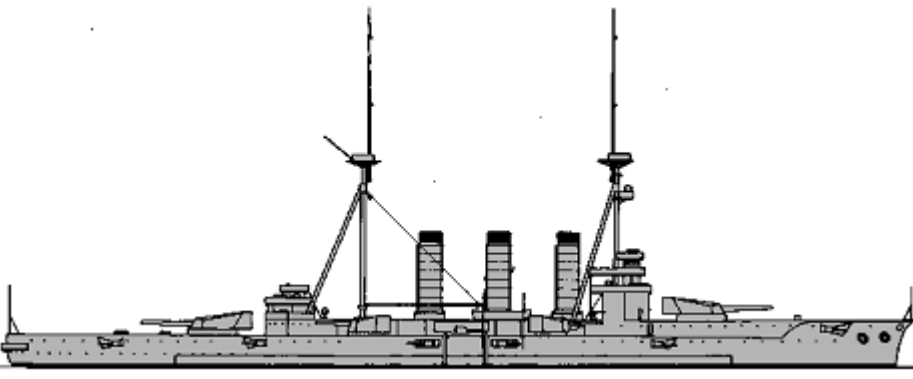
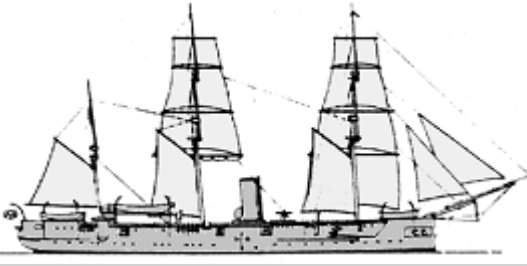

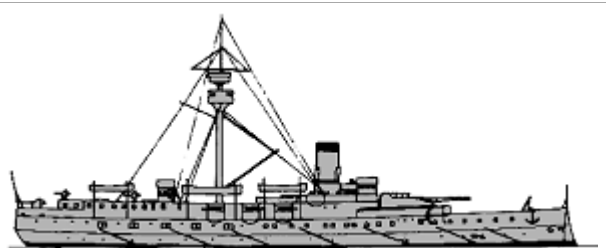
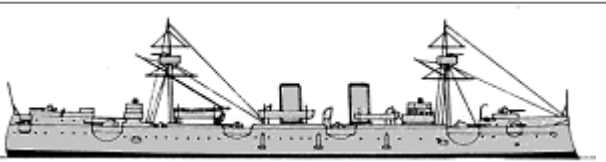
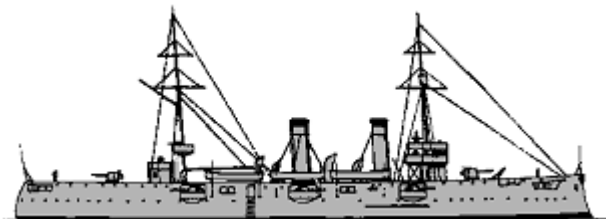
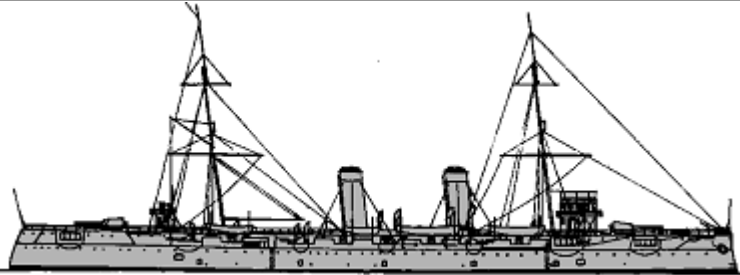
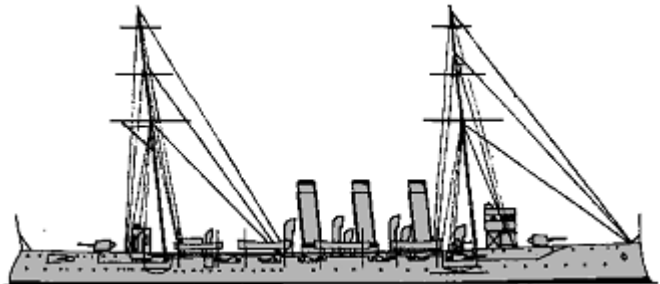
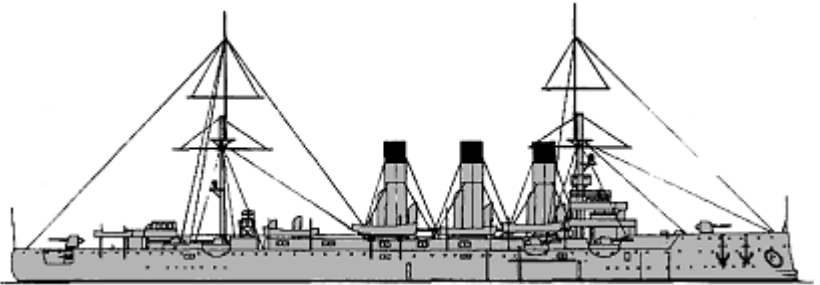

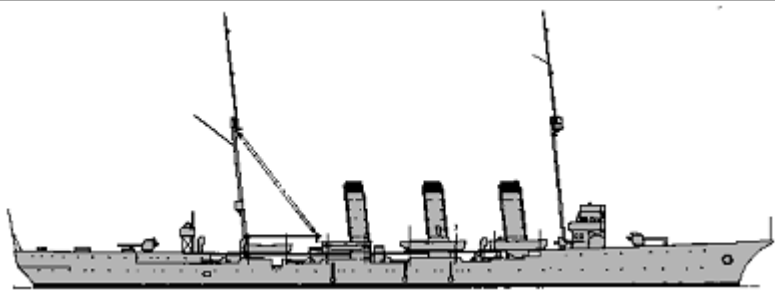
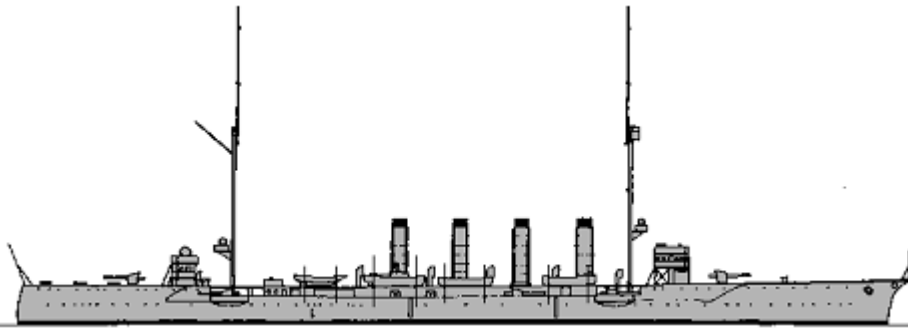
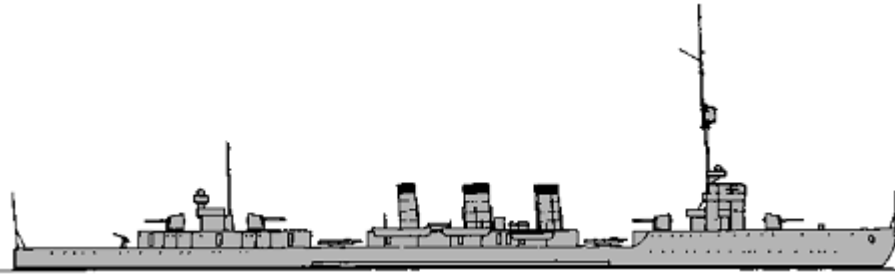
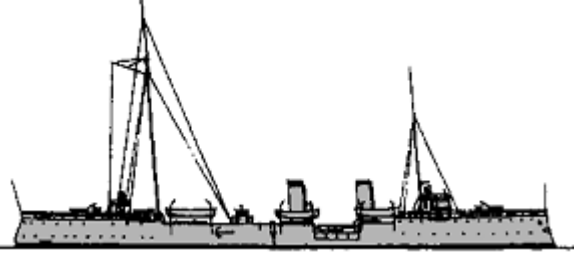
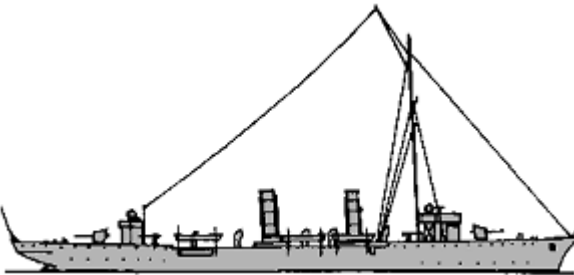
Kasuga	8	Kasuga	1904		8500t, 111.7x18.9x7.3m, 12b,2vte, 13500hp, 20kts, 600p; 150belt, 38deck, 150turrets, 150CT; 1x1-254/40(8), 1x2-203/45(8), 2x2-203/45(9), 14x1-152/40, 10x1-76/40, 6x1-47/40(8), 4x1-47/40(9), 4-450TT
	9	Nisshin	1904		
Tsukuba	1 10	Ikoma	1908		15400t, 137.1x22.8x8.0m, 20b,2vte, 20500hp, 20.5kts, 879p; 178belt, 76deck, 178turrets, 203CT; 2x2-305/45, 10x1-152/45, 8x1-120/40, 6x1-76/40, 3-450TT
Aso	1 11	Aso	1903		7800t, 137.0x17.5x6.5m, 26b,2vte, 16500hp, 21kts, 593p; Harvey- 200belt, 50deck, 100turrets, 160CT; 2x1-152/50, 8x1-152/45, 16x1-76/40
Ibuki	12	Ibuki	1909		15595t, 147.8x23.0x8.0m, 18b,2st(13)-28b,2vte(14), 24000(13)-22500(14)hp, 21.5(13)-20.5(14)kts, 844p; 178belt, 76deck, 178turrets, 203CT; 2x2-305/45, 4x2-203/45, 14x1-120/40, 4x1-76/40, 3-450TT
	2 13	Kurama	1911		
Katsuragi	1	Yamato	1888		1502t, 62.8x10.7x4.6m, 6b,1hcra, 1622hp, 13kts, 231p; 2x1-76/40
	2 2	Musashi	1887		
Itsukushima	1 3	Hashidate	1894		4217t, 99.8x15.4x6.0m, 8b,2hte, 5400hp, 16.5kts, 360p; Harvey- 40deck, 100turret, 125CT; 1x1-320/38, 11x1-120/40, 6x1-57/40, 11x1-37/20, 4-350TT

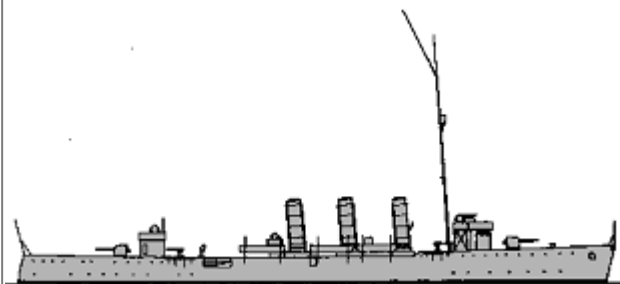

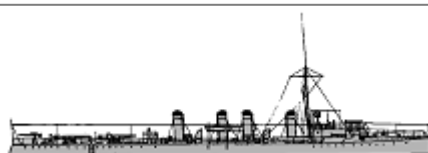

						
	Akitsushima	1 4	Akitsushima	1894		3150t, 92.0x13.1x5.3m, 6b,2vte, 8400hp, 19kts, 314p; Harvey- 76deck, 114shields; 4x1-152/40, 6x1-120/40, 8x1-47/40, 4-350TT
	Suma	5	Suma	1896		2657(5)-2756(6)t, 95.0(5)-93.3(6)x12.2(5)-12.7(6)x4.6(5)-4.8(6)m, 4b,2vte(5)-9b,2vte(6), 8500hp, 20kts, 310p; Harvey- 51slopes, 25deck, 114shields; 2x1-152/40, 6x1-120/40, 10x1-47/40, 4x1-47/30, 2-380TT
		6	Akashi	1899		
	Chitose	2 7	Chitose	1899		5598t, 120.4x15.0x5.4m, 8b,2vte, 15000hp, 22.5kts, 434p; Harvey- 114slopes, 45deck, 114shields, 114CT; 2x1-203/45, 10x1-120/40, 12x1-76/40, 6x1-47/30, 5-350TT
CL	Tsushima	8	Niitaka	1904		3716t, 104.1x13.4x4.9m, 16b,2vte, 9500hp, 20kts, 320p; 64slopes, 38deck, 25shields, 102CT; 6x1-152/40, 10x1-76/40, 4x1-47/30
		9	Tsushima	1904		
	Tsugaru	1 10	Tsugaru	1902		7900t, 126.8x16.8x6.6m, 24b,3vte, 12000hp, 19kts, 581p; 76slopes, 51deck, 152CT; 2x1-152/50, 8x1-152/45, 12x1-76/40
	Tone	1 11	Tone	1910		4900t, 113.8wlx14.4x5.1m, 16b,2vte, 15000hp, 23kts, 370p; 76slopes, 38deck, 25shields, 102CT; 2x1-152/45, 8x1-120/40, 4x1-76/40, 3-450TT

						
Chikuma	3	12	Chikuma	1912		5040t, 144.8x14.2x5.1m, 16b,2st, 22500hp, 26kts, 414p; 89belt, 57deck, 25shields, 102CT; 8x1-152/45, 4x1-76/40, 3-450TT
		13	Hirado	1912		
		14	Yahagi	1912		
Tenryu	2	15	Tenryu	1919		4350t, 142.9x12.3x4.0m, 10b,3gt, 51000hp, 33kts, 327p; 63belt, 25deck, 20shields, 51CT; 4x1-140/50, 1x1-76/40, 2x3-533TT, 48mines
		16	Tatsuta	1919		
CLL	1	1	Chihaya	1901		1464t, 87.7x9.6x2.8m, 4b,2vte, 6000hp, 21kts, 125p; 2x1-120/40, 4x1-76/40, 2x1-450TT
		2	Yodo	1908		1250t, 93.1x9.8x3.0m, 4b,2vc, 6500hp, 22kts, 180p; 63slopes, 63deck, 51CT; 2x1-120/40, 4x1-76/40, 2x1-450TT
		3	Mogami	1908		1350t, 96.3x9.8x3.0m, 6b,3st, 8000hp, 23kts, 180p; 63slopes, 63deck, 51CT; 2x1-120/40, 4x1-76/40, 2x1-450TT





## TORPEDO SHIPS





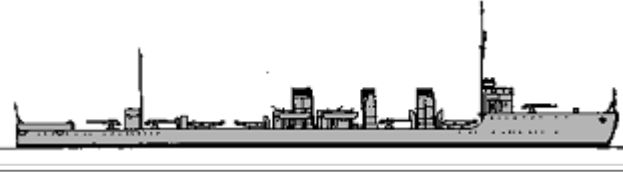
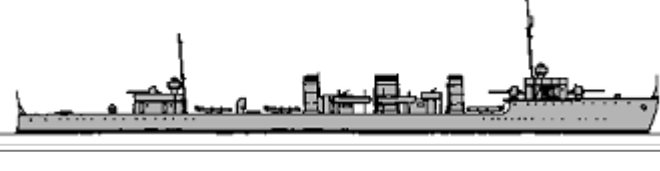
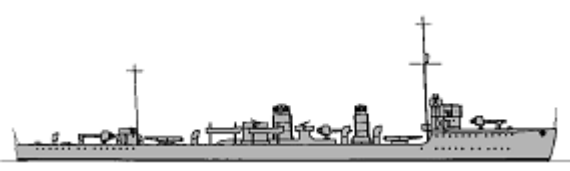
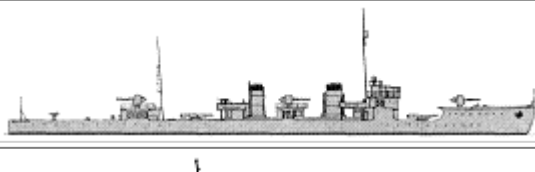



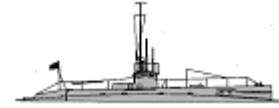

Murakumo	4	1	Murakumo	1898		361t, 65.7x6.0x1.7m, 3b,2vte, 5800hp, 30kts, 54p; 2x1-76/40, 4x1-57/40, 2x1-450TT
		2	Shiranui	1899		
		3	Usugumo	1900		
		4	Yugiri	1899		
Ikazuchi	2	5	Akebono	1899		410t, 68.5x6.3x1.6m, 4b,2vte, 6000hp, 31kts, 55p; 2x1-76/40, 4x1-57/40, 2x1-450TT
		6	Oboro	1899		
Shirakumo	2	7	Shirakumo	1902		428t, 67.5x6.3x1.8m, 4b,2vte, 7000hp, 31kts, 59p; 2x1-76/40, 4x1-57/40, 2x1-450TT
		8	Asashio	1902		
Harusame	5	9	Asagiri	1903		435t, 71.4x6.6x1.8m, 4b,2vte, 6000hp, 29kts, 55p; 2x1-76/40, 4x1-57/40, 2x1-450TT
		10	Murasame	1903		
		11	Ariake	1905		
		12	Arare	1905		
		13	Fubuki	1905		
Asakaze	30	14	Asakaze	1906		450t, 72.0x6.6x1.8m, 4b,2vte, 6000hp, 29kts, 70p; 2x1-76/40, 4x1-76/23, 2x1-450TT
		15	Wakaba	1906		
		16	Ushio	1905		
		17	Nenohi	1905		
		18	Kisaragi	1905		
		19	Kamikaze	1905		
		20	Hatsushimo	1905		
		21	Yugure	1906		
		22	Harukaze	1906		
		23	Yayoi	1905		
		24	Oite	1906		
		25	Hibiki	1906		
26	Hatsuyuki	1906				
27	Yudachi	1906				
28	Nowaki	1906				
29	Mikazuki	1906				

DD								
		30	Shigure	1906				
		31	Hatsuharu	1907				
		32	Shiratsuyu	1906				
		33	Shirayuki	1906				
		34	Matsukaze	1907				
		35	Nagatsuki	1907				
		36	Yunagi	1906				
		37	Uzuki	1907				
		38	Minazuki	1907				
		39	Hayate	1907				
		40	Kikuzuki	1907				
		41	Uranami	1908				
	42	Isonami	1909					
	43	Ayanami	1909					
	Umikaze	2	44	Umikaze	1911		1150t, 98.5x8.5x2.7m, 8b,3st, 20500hp, 33kts, 140p; 2x1-120/40, 5x1-76/40, 2x2-450TT(44), 3x1-450TT(45)	
			45	Yamakaze	1911			
	Sakura	2	46	Sakura	1912		830t, 83.6x7.3x2.2m, 5b,3vte, 9500hp, 30kts, 92p; 1x1-120/40, 4x1-76/40, 2x2-450TT	
			47	Tachibana	1912			
	Urakaze	1	48	Urakaze	1915		1085t, 87.2x8.4x2.4m, 3b,2st, 22000hp, 30kts, 120p; 1x1-120/40, 4x1-76/40, 2x2-533TT	
	Kaba	10	49	Kaba	1915		850t, 83.6x7.3x2.3m, 4b,3vte, 9500hp, 30kts, 92p; 1x1-120/40, 4x1-76/40, 2x2-450TT	
			50	Matsu	1915			
			51	Kashiwa	1915			
			52	Katsura	1915			
			53	Kaede	1915			
			54	Kiri	1915			
			55	Kusunoki	1915			
			56	Ume	1915			
			57	Sakaki	1915			
			58	Sugi	1915			
	Momo	4	59	Momo	1916		1080t, 85.6wx7.7x2.3m, 4b,2gt, 16000hp, 31.5kts, 110p; 3x1-120/40, 2x3-450TT	
			60	Kashi	1917			





		61	Hinoki	1917			
		62	Yanagi	1917			
Amatsukaze	4	63	Amatsukaze	1917		1570t, 96.9x8.5x2.8m, 5b,3st, 27000hp, 34kts, 128p; 4x1-120/40, 3x2-450TT	
		64	Isokaze	1917			
		65	Tokitsukaze	1917			
		66	Hamakaze	1917			
Kawakaze	2	67	Kawakaze	1918		1580t, 103.6x8.8x2.8m, 4b,2gt(67)-4b,2st(68), 34000hp, 37.5kts, 128p; 3x1-120/45, 3x2-533TT	
		68	Tanikaze	1919			
Enoki	6	69	Enoki	1918		1100t, 85.8wlx7.7x2.3m, 4b,2gt, 17500hp, 31.5kts, 110p; 3x1-120/40, 2x3-450TT	
		70	Nara	1918			
		71	Tsubaki	1918			
		72	Kuwa	1918			
		73	Keyaki	1918			
		74	Maki	1918			
Momi	3	75	Momi	1919		1020t, 85.3x7.9x2.4m, 3b,2gt, 21500hp, 36kts, 110p; 3x1-120/45, 2x2-533TT, 20mines, sweeps	
		76	Nashi	1919			
		77	Take	1919			
TB1	Shirataka	1	1	Shirataka	1900		126t, 46.5x5.1x1.3m, 2b,2vte, 2600hp, 28kts, 26p; 1x1-76/40, 2x1-57/40, 3x1-350TT
	Hayabusa	12	2	Manazuru	1900		150t, 46.4x4.9x1.5m, 2b,2vte, 4200hp, 29kts, 30p; 1x1-57/40, 2x1-47/30, (1+2x1)-450TT
			3	Aotaka	1903		
			4	Uzura	1904		
			5	Hashitaka	1904		
			6	Hato	1903		
			7	Hibari	1904		
			8	Kamome	1904		
			9	Kari	1903		
			10	Kiji	1904		
			11	Otori	1904		
			12	Sagi	1904		
			13	Tsubame	1903		
			TB2	67-go	8		

## SUBMARINES

SS	Holland	1	1-go	1905		103/124t, 20.4x3.6x3.1m, 1pe/em, 180/70hp, 8/7kts, 13p, 30m; 1-450TT	
		2	2-go	1905			
		3	3-go	1905			
		4	4-go	1905			
		5	5-go	1905			
	Kaigun-Holland	2	6, 7	6-go, 7-go	1906		78/95(6)-57/63(7)t, 25.7(6)-22.5(7)x2.4(6)-2.1(7)x2.3(6)-2.0(7)m, 1pe/em, 300/22hp, 8.5/4kts, 14p, 30m; 1-450TT
	C1	2	8	8-go	1909		286/321t, 43.3x4.1x3.4m, 1pe/em, 600/300hp, 12/8.5kts, 26p, 30m; 2-450TT
			9	9-go	1909		
	C2	3	10	10-go	1911		291/326t, 43.3x4.1x3.4m, 1pe/em, 600/300hp, 12/8.5kts, 25p, 30m; 2-450TT
			11	11-go	1911		
			12	12-go	1911		
	Vickers/Kawasaki	1	13	13-go	1912		304/340t, 38.6x3.8x3.1m, 1pe/em, 1000/300hp, 10.8/8kts, 26p, 30m; 2-450TT
	C3	2	14	16-go	1916		290/326t, 43.7x4.1x3.4m, 1pe/em, 600/300hp, 12/8.5kts, 26p, 30m; (2+2x1)-450TT
15			17-go	1917			
S1	1	16	15-go	1917		418/665t, 56.7x5.2x3.1m, 2d/em, 2000/850hp, 17/10kts, 30p, 30m; 1x1-76/40, 4-450TT	
UC III	2	17	O4	1918		491/571t, 56.5x5.5x3.8m, 2d/em, 600/770hp, 11.5/6.6kts, 32p, 75m; 1x1-105/42, 3-500TT, 14mines	
		18	O5	1918			
UB III	2	19	O6	1918		512/643(19)-523/653(20)t, 55.9x5.8x3.7(19)-3.8(20)m, 2d/em, 1060/788hp, 13.9/7.6(19)-13.5/7.5(20)kts, 34p, 50m; 1x1-105/42, 5-500TT	
		20	O7	1918			
K1	2	21	19-go	1919		735/1030t, 69.2x6.4x3.4m, 2d/em, 2600/1200hp, 18/9kts, 44p, 30m; 1x1-76/23, 6-450TT	
		22	20-go	1919			
UE II	1	23	O1	1918		1163/1468t, 82.0x7.4x4.2m, 2d/em, 2400/1235hp, 14.7/7.2kts, 40p, 75m; 1x1-149/42, 4-500TT, 42mines	
U51	1	24	O3	1916		715/902t, 65.2x6.4x3.6m, 2d/em, 2400/1200hp, 17.1/9.1kts, 36p, 50m; 2x1-88/27, 4-500TT	

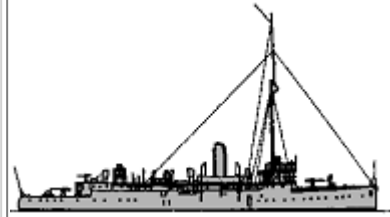
## OTHER FIGHTING SHIPS

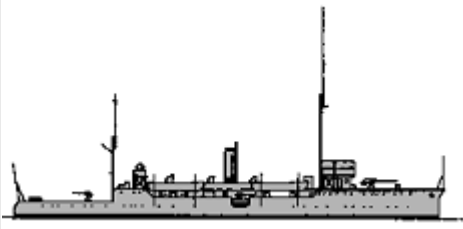
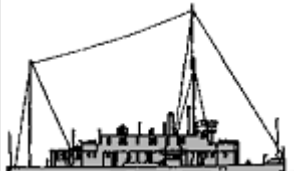
		1	1	Uji	1903		620t, 57.8x8.4x2.1m, 2b,2vte, 1000hp, 13kts, 86p; 4x1-76/40
--	--	---	---	-----	------	--	---

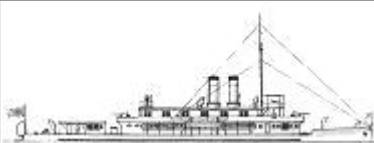
PG	Saga	1	2	Saga	1912		885t, 69.0x9.0x2.2m, 2b,3vte, 1600hp, 15kts, 98p; 1x1-120/45, 3x1-76/40
PGR	Sumida	1	1	Sumida	1906		126t, 44.2ppx7.2x0.6m, 2b,3vte, 550hp, 13kts, 40p; 2x1-47/40
	Fushimi	1	2	Fushimi	1906		180t, 48.7ppx7.4x0.7m, 2b,3vte, 900hp, 14kts, 45p; 2x1-57/40
	Toba	1	3	Toba	1911		291t, 55.9x8.2x0.8m, 2b,3vte, 1400hp, 15kts, 59p; 2x1-76/23

MINE WARFARE SHIPS

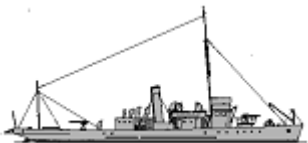
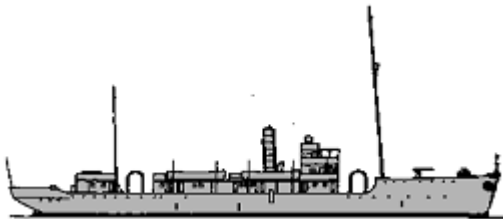
ML	Natsushima	10	1	Natsushima	1912		435t, 45.7x7.6x2.3m, 1b,1vte, 600hp, 12.8kts, 40p; 2x1-76/40, 60mines, sweeps
			2	Sokuten	1913		
			3	Toshima	1915		
			4	Kuroshima	1915		
			5	Ashizaki	1916		
			6	Katoku	1916		
			7	Kurokami	1917		
			8	Katashima	1917		
			9	Ento	1917		
			10	Enoshima	1919		
	Katsuriki	1	11	Katsuriki	1917		2000t, 73.1wx11.9x4.3m, 2b,2vte, 1800hp, 13kts; 3x1-76/40, 150mines



© Ivan Gogin, 2014

[home](#)

[World navies yesterday](#)

[1920](#)

## Latvia 01 January 1920

### ESCORTS



PC	Virsaitis	1	1	Virsaitis	1917		539t, 59.3x7.4x2.2m, 2b,2vte, 1850hp, 16kts, 51p; 2x1-88/42, 30mines, sweeps
----	-----------	---	---	-----------	------	--	--

© Ivan Gogin, 2015



[home](#)[World navies yesterday](#)[1920](#)

## Mexico 01 January 1920

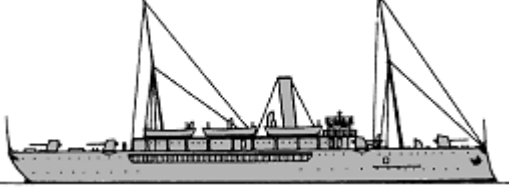
### CRUISERS

CL	Porfirio Díaz	1	1	Zaragoza	1892		1200t, 68.0x9.3x4.3m, 2b,1vte, 1300hp, 15kts, 270p; 4x1-120/40, 2x1-57/40
CP	Progreso	1	1	Progreso	1907		1700t, 70.1x10.3x3.0m, 1vte, 1400hp, 13kts, 140p; 4x1-57/40; troops
	Vincente Guerrero	1	2	Vincente Guerrero	1908		1850t, 74.6ppx13.2x5.3m, 1vte, 1500hp, 12kts, 300p; 6x1-102/40, 2x1-47/50; 550troops, 45horses

### OTHER FIGHTING SHIPS



PG	Tampico	1	1	Vera Cruz	1902		980t, 61.0ppx10.1x3.4m, 2vte, 2400hp, 16kts, 98p; 2x1-102/40, 6x1-57/40, 1-356TT, 200troops
	Nicholas Bravo	2	3	Morales	1904		1493t, 73.8x10.4x3.0m, 2vte, 2565hp, 17kts, 116p; 2x1-102/40, 6x1-57/40, 1-356TT

© Ivan Gogin, 2015

[home](#)[World navies yesterday](#)[1920](#)

# Netherlands 01 January 1920

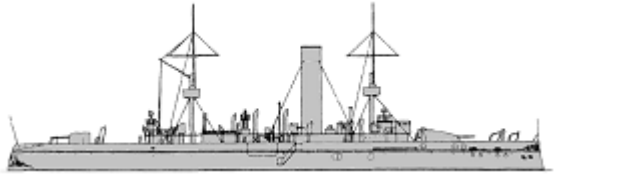

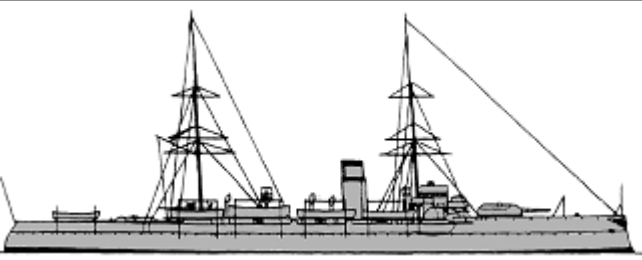
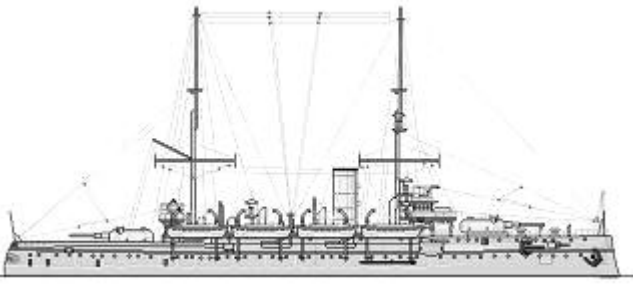
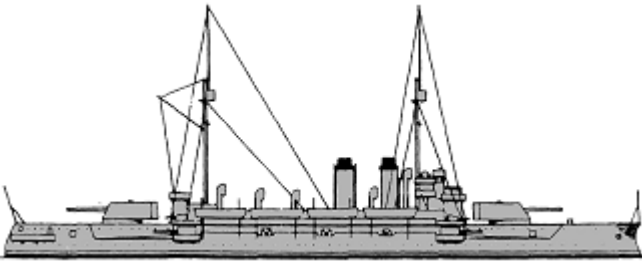



## BATTLESHIPS

BC	Evertsen	1	1	Kortenaer	1895		3464t, 86.2x14.3x5.2m, 6b,2vte, 4700hp, 16kts, 263p; steel- 150belt, 55deck, 240barbette, 240CT; (1x2+1x1)-209/32, 2x1-149/32, 6x1-75/27, 8x1-37/20, 3-450TT
	Koningin Regentes	3	2	Koningin Regentes	1901		5002(2,3)-5084(4)t, 96.6x15.2x5.8m, 6b,2vte, 6500hp, 16.5kts, 340p; 150belt, 50deck, 100turrets, 250CT; 2x1-238/37, 4x1-149/37, 8x1-75/37, 4x1-37/20, 3-450TT
			3	De Ruyter	1902		
			4	Hertog Hendrik	1904		
	Marten Harpertzoon Tromp	1	5	Marten Harpertzoon Tromp	1905		5295t, 100.8x15.2x5.7m, 8b,2vte, 6400hp, 16.5kts, 340p; 150belt, 50deck, 100turrets, 195CT; 2x1-238/37, 4x1-149/37, 8x1-75/37, 4x1-37/20, 3-450TT
	Jacob van Heemskerck	1	6	Jacob van Heemskerck	1908		4920t, 98.0x15.2x5.7m, 8b,2vte, 6400hp, 16.5kts, 340p; 150belt, 50deck, 100turrets, 195CT; 2x1-238/37, 6x1-149/37, 6x1-75/37, 4x1-37/20, 2-450TT
De Zeven Provinciën	1	7	De Zeven Provinciën	1910		6510t, 103.5x17.1x6.2m, 8b,2vte, 8000hp, 16kts, 448p; 150belt, 50deck, 250turrets, 200CT; 2x1-283/40, 4x1-149/37, 10x1-75/52, 2x1-37/20	

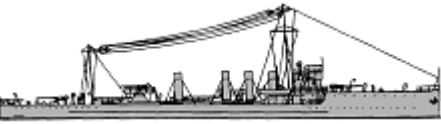
## CRUISERS

CL	Holland	4	1	Holland	1898		3840(1,2)-3970(3,4)t, 93.3(1,2)-94.7(3,4)x14.8x5.4m, 8b,2vte(1,2)-10b,2vte(3,4), 10000hp, 20kts, 371p; Harvey- 57deck, 152shields, 102CT; 8x1-120/37(1-3), 10x1-120/37(4), 4x1-75/37, 1-450TT(4)
			2	Zeeland	1898		
			3	Gelderland	1900		
			4	Noord Brabant	1900		

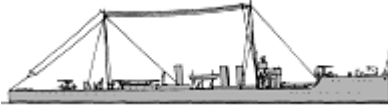





## TORPEDO SHIPS

DD	Fret	8	1	Fret	1911		510t, 70.4x6.60x2.0m, 4b,2st, 8500hp, 30kts, 83p; 4x1-75/52, 2x1-450TT
			2	Wolf	1911		
			3	Bulhond	1912		
			4	Jakhals	1912		
			5	Hermelijn	1913		
			6	Lynx	1913		
			7	Panter	1914		
			8	Vos	1914		
TB1cl	No.XXIII	1	1	Cerberus	1888		82t, 38.2x4.0x1.8m, 1b,1vc, 912hp, 21.2kts, 16p; 2x1-37/20, (1+2x1)-450TT
	Hydra	5	2	Hydra	1900		103t, 39.6x4.1x2.1m, 2b,1vte, 1500hp, 24kts, 21p; 2x1-37/20, 3x1-450TT
			3	Scylla	1900		
			4	Minotaurus	1902		
			5	Python	1902		
	Draak	3	6	Sphinx	1903		103t, 39.6x4.1x2.2m, 2b,1vte, 1500hp, 24kts, 21p; 2x1-37/20, (1+1x1)-450TT
			7	Draak	1907		
			8	Krokodil	1907		
	G13	4	9	Zeeslang	1907		230t, 49.5ppx5.3x1.5m, 2b,2vte, 2600hp, 25kts, 27p; 2x1-75/37, 3x1-450TT
			10	G13	1914		
			11	G14	1914		
			12	G15	1914		
	Z5	4	13	G16	1914		310t, 58.5ppx6.1x1.7m, 3b,2vte, 5500hp, 27kts, 46p; 2x1-75/37, 2x1-12.7/87, (1x2+2x1)-450TT
			17	Z5	1917		
			18	Z6	1917		
19			Z7	1916			
Z1	1	20	Z8	1916		322t, 62.6x6.2x1.9m, 3b,2st, 5500hp, 27kts, 46p; 2x1-75/37, 2x1-12.7/87, (1x2+2x1)-450TT	
		21	Z1	1919			
		1-	K1 Michiel Gardeyn, K2 Christiaan Cornelis, K3 Willem				



TB2cl	K1	3	3	Warmont	1905	No picture	47t, 30.0x3.6x1.7m, 1b,1vte, 560hp, 18.7kts, 12p; 2x1-37/20, 2-356TT
-------	----	---	---	---------	------	------------	--

## SUBMARINES





SS	O1	1	1	O1	1906		105/124t, 20.4x4.9x2.8m, 1d/em, 200/80hp, 9/6kts, 10p, 25m; 1-250TT
	O2	4	2	O2	1911		130/150t, 32.1x3.3x2.7m, 1d/em, 350/200hp, 11/8.6kts, 10p, 25m; 2-450TT
			3	O3	1913		
			4	O4	1914		
			5	O5	1914		
	K I	1	6	K I	1914		330/386t, 48.6x4.7x3.0m, 2d/em, 1800/500hp, 17/10.5kts, 17p, 40m; 3-450TT
	O6	1	7	O6	1916		189/229t, 35.7x4.1x3.1m, 1d/em, 375/185hp, 12/8.5kts, 15p, 40m; 3-450TT
	O7	1	8	O7	1916		176/206t, 34.7x3.9x2.9m, 1d/em, 350/185hp, 11.5/8.5kts, 15p, 40m; 3-450TT
M1	1	9	M1	1915		168/183t, 34.0x3.2x3.0m, 1d/em, 90/175hp, 6.2/5.2kts, 14p, 50m; 12mines	
O8	1	10	O8	1915		364/434t, 45.8x4.7x3.8m, 2d/em, 480/620hp, 13/11kts, 22p, 50m; 4-450TT	

## ESCORTS

PC	Albatros	1	1	Albatros	1912	No picture	892t, 50.0ppx9.4x3.3m, 1vte, 1140hp, 12kts, 47p; 2x1-37/45
	Orion	1	2	Orion	1912	No picture	1062t, 55.9ppx9.0x3.7m, 1vte, 1380hp, 14kts, 71p; 2x1-75/52
	Aldebaran	1	3	Aldebaran	1913	No picture	892t, 53.3ppx8.2x3.5m, 1vte, 800hp, 12kts, 45p; 2x1-37/45
	Bellatrix	3	4	Bellatrix	1914	No picture	763-773t, 53.3ppx9.0x3.0m, 1vte, 800hp, 12kts, 45p; 1x1-75/52(4), 2x1-37/45(5,6)
			5	Canopus	1915		
			6	Deneb	1915		
	Eridanus	1	7	Eridanus	1918	No picture	996t, 56.5ppx9.0x3.2m, 1vte, 800hp, 44p; 1x1-75/52
Gemma	1	8	Gemma	1918	No picture	845t, 53.3ppx9.0x3.2m, 1vte, 800hp, 44p; 1x1-75/52	
AFPV	-	2	1	Dolfijn	1889		
			2	Zeehond	1892		

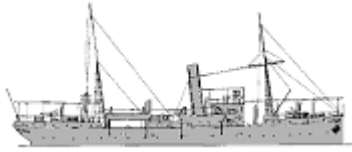
## OTHER FIGHTING SHIPS

	Nias	1	1	Serdang	1897		810-820t, 53.9x9.4x3.7m, 2vte, 1300hp, 12.9kts, 97p; 2x1-105/32, 4x1-37/20, 2x5-37/17
--	------	---	---	---------	------	---	---

PG	Koetei	1	2	Koetei	1898		788t, 53.7x9.4x3.7m, 2vte, 1380hp, 13.7kts, 97p; 2x1-105/32, 4x1-37/20, 2x5-37/17
	Brinio	3	3	Brinio	1914		573-634t, 52.7x8.5x2.8m, 2d, 1200(3,4)-1500(5)hp, 14kts, 52p; 55belt, 17deck, 50shields, 50CT; 4x1-105/47, 2x1-12.7/90
			4	Friso	1915		
			5	Gruno	1915		
	Hydra	2	6	Los	1875		221t, 25.9x8.0x2.2m, 2b,1vc, 124-146hp, 7.5-8kts, 34p; 1x1-209/32, 2x1-37/20, 1x5-37/20
			7	Sperwer	1875		
	Wodan	7	8	Wodan	1877		264-280t, 27.8x8.2x2.3m, 2b,1vc, 101-171hp, 7-8.3kts, 34p; 1x1-283/27(13,14), 1x1-283/20(9-12), 1x1-120/37(8), 2x1-37/20, 1x5-37/17
			9	Braga	1879		
			10	Freyr	1877		
			11	Njord	1878		
			12	Tyr	1878		
			13	Hefring	1880		
			14	Bulgia	1884		

## MINE WARFARE SHIPS

ML	Hydra	2	1	Das	1876		221t, 25.9x8.0x2.2m, 2b,1vc, 124-146hp, 7.5-8kts, 34p; 2x1-37/20, mines
			2	Havik	1874		
	Wodan	4	3	Hadda	1880		264-280t, 27.8x8.2x2.3m, 2b,1vc, 101-171hp, 7-8.3kts, 34p; 1x1-149/37(6), 2x1-37/20, 1x5-37/17, mines
			4	Balder	1879		
			5	Vidar	1879		
			6	Thor	1877		
	Koetei	2	7	Siboga	1898		788t, 53.7x9.4x3.7m, 2vte, 1380hp, 13.7kts, 97p; 1x1-105/32, 4x1-37/20, 2x5-37/17, mines
			8	Assahan	1900		
	Hydra	2	9	Hydra	1912		670t, 49.7x9.0x2.8m, 2b,2vte, 900hp, 11kts, 59p; 3x1-75/52, 2x1-12.7/90, 70mines
			10	Medusa	1911		
MS	Nr.1	4	1	M1	1918	No picture	205-238t, 29.7-30.5x6.4-7.0x2.5-3.1m, 1b,1vte, 450-500hp, 9.5-10kts, 16p; 1x1-12.7/90, sweeps
			2	M2	1918		
			3	M3	1918		
			4	M4	1918		



© Ivan Gogin, 2014

[home](#)[World navies yesterday](#)[1920](#)

## New Zealand 01 January 1920

### CRUISERS

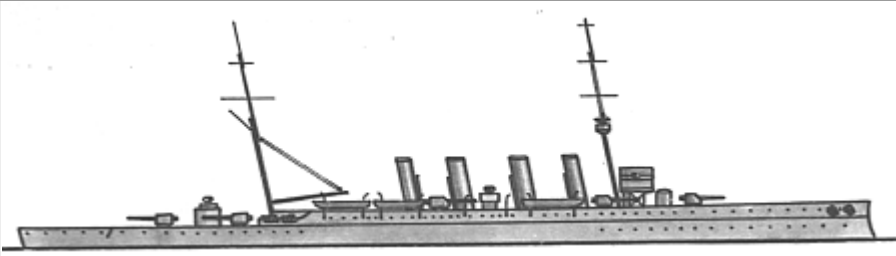
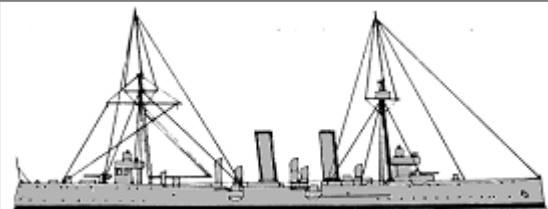
CL	Chatham	1	1	Chatham	1912		6000t, 139.6x14.9x4.9m, 12b,4st, 25000hp, 25.5kts, 475p; 51belt, 38deck, 102shields, 102CT; 8x1-152/50, 1x1-76/45, 4x1-47/40, 2-533TT
CLL	Pearl	1	1	Philomel	1891		2575t, 84.7x12.5x4.7m, 4b,2vte, 7500hp, 19kts, 217p; steel: 51deck, 51shields, 76CT; 8x1-120/40, 8x1-47/40, 4x1-11.4, (2+2)-356TT/TC

### OTHER FIGHTING SHIPS

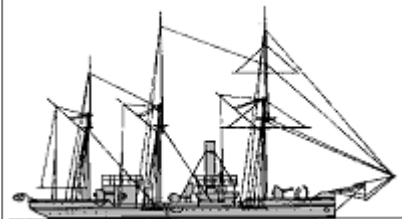
PG	Redbreast	1	1	Amokura (TS)	1890		805t, 50.3ppx9.5x3.4m, 2b,1vte, 1200hp, 13kts, 76p; 6x1-102/27, 2x1-47/40, 2x1-11.4
----	-----------	---	---	--------------	------	--	---

Google  
Custom Search

© Ivan Gogin, 2014

[home](#)

[World navies yesterday](#)

[1920](#)

## Nicaragua 01 January 1920

### OTHER FIGHTING SHIPS

PG	Momotombo	1	1	Momotombo	1918	No picture	400t; 2x1-76/40, 1x1-57/40
----	-----------	---	---	-----------	------	------------	----------------------------

© Ivan Gogin, 2015

[home](#)[World navies yesterday](#)[1920](#)

## Norway 01 January 1920

### BATTLESHIPS

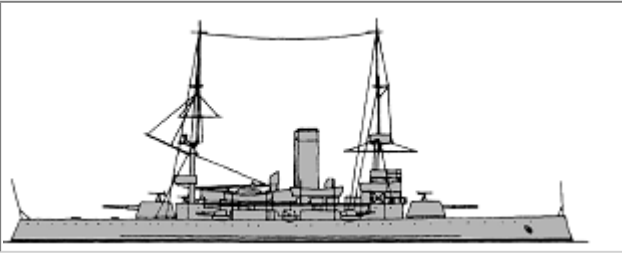
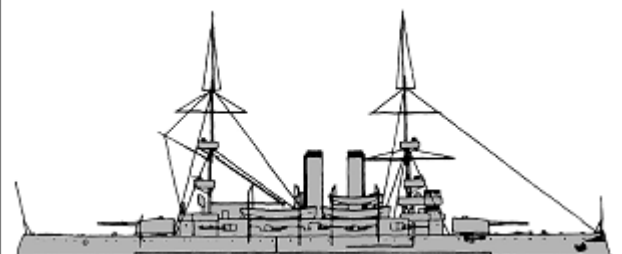
BC	Harald Haarfagre	1	Harald Haarfagre	1898		3858t, 92.7x14.8x5.4m, 3b,2vte, 4000hp, 16.9kts, 245p; Harvey- 178belt, 51deck, 203turrets, 152CT; 2x1-209/44, 6x1-120/44, 6x1-76/40, 6x1-37/45, 2-450TT
		2	Tordenskjold	1898		
	Norge	3	Norge	1901		4166t, 94.6x15.4x5.4m, 6b,2vte, 4500hp, 16.5kts, 266p; 152belt, 51deck, 203turrets, 152CT; 2x1-209/44, 6x1-149/46, 8x1-76/40, 4x1-47/46, 2-450TT
		4	Eidsvold	1901		

### CRUISERS

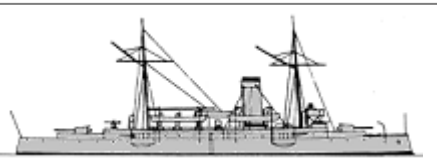
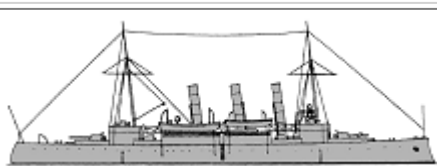

CL	Viking	1	Viking	1891		1181t, 63.5x9.3x3.7m, 4b,2vc, 2000hp, 15kts, 125p; Harvey- 35deck, 25shields, 35CT; 1x1-149/46, 1x1-120/44, 4x1-76/40, 2x1-75/37, 6x1-47/40, 1-356TT
	Frithjof	1	Frithjof	1896		1427t, 68.2x10.0x4.0m, 6b,2vte, 2800hp, 15kts, 154p; Harvey- 30deck; 2x1-120/44, 4x1-76/40, 4x1-37/45, 1-450TT

### TORPEDO SHIPS

DD	Valkirjen	1	Valkirjen	1896		415t, 59.4x7.4x2.6m, 2b,2vte, 3300hp, 23kts, 59p; 2x1-76/40, 4x1-37/45, 2x1-450TT
		2	Draug	1909		

	Draug	3	3	Troll	1912		578(2,3)-597(4)t, 69.2x7.3x2.9m, 4b,2vte(2,3)-4b,2st(4), 7500(2,3)-8000(4)hp, 26.5(2)-27(3)-27.4(4)kts, 76p; 6x1-76/40, 3x1-450TT
			4	Garm	1914		
TB1cl	Hval	3	1	Hval	1896		102t, 39.9x4.8x2.2m, 2b,1vte, 1100hp, 21kts, 23p; 2x1-37/45, 2x1-450TT
			2	Delfin	1896		
			3	Hai	1896		
	Storm	3	4	Storm	1898		107t, 39.9x4.8x2.2m, 2b,1vte, 1100hp, 21kts, 23p; 2x1-37/45, 2x1-450TT
			5	Brand	1898		
			6	Trods	1898		
	Laks	4	7	Laks	1900		107t, 38.5x4.8x2.2m, 2b,1vte, 1150hp, 21kts, 23p; 2x1-37/45, 2x1-450TT
			8	Sild	1900		
			9	Sæl	1901		
			10	Skrei	1901		
TB2cl	Rap	1	1	Rap	1873		15t, 17.3x2.3x0.9m, 1b,1hda, 90hp, 15kts, 6p
	Ulven	1	2	Ulven	1878		16t, 17.2x2.9x1.1m, 1b,1hda, 70hp, 10kts, 6p
	Od	1	3	Od	1882		41t, 29.0xxm, 1b,1vc, 420hp, 18kts; 1x1-37/20, 1-356TT
	Springer	1	4	Springer	1883		44t, 30.0xxm, 1b,1vc, 420hp, 18kts; 1x1-37/20, 2-356TT
	Rask	2	5, 6	Rask, Pil	1885-1886		44t, 30.5xxm, 1b,1vc, 500hp, 19kts; 1x1-37/20, 2-356TT
	Snar	1	7	Snar	1887		49t, 32.0xxm, 2b,1vc, 600hp, 19kts; 1x1-37/20, 2-356TT
	Orm	2	8, 9	Orm, Oter	1888		54t, 33.0xxm, 2b,1vc, 600hp, 19kts; 1x1-37/20, 2-381TT
	Varg	2	10, 11	Varg, Raket	1894		64t, 34.5x3.8x1.6m, 2b,1vte, 650hp, 19kts, 12p; 1x5-37/12, 2-450TT
	Lyn	3	12-14	Lyn, Blink, Glimt	1896-1897		64t, 34.5x3.8x1.8m, 2b,1vte, 650hp, 19kts, 21p; 1x1-37/45, (1+1x1)-450TT
	Djerv	3	15-17	Djerv, Kvikk, Dristig	1897-1898		66t, 34.5x3.8x1.7m, 2b,1vte, 650hp, 19kts, 21p; 2x1-37/45, (1+1x1)-450TT
	Myg	1	18	Myg	1900		27t, 25.0xxm, 1b,1vc, 285hp, 17.7kts; 1x1-37/45, 1-356TT
	Hvass	2	19, 20	Hvass, Kjæk	1901		74t, 34.1x4.4x1.6m, 2b,2vte, 650hp, 19kts, 16p; 2x1-37/45, (1+1x1)-450TT
	Hauk	2	21, 22	Hauk, Falk	1904		73t, 34.9x4.4x1.6m, 2b,2vte, 750hp, 20kts, 16p; 2x1-37/45, (1+1x1)-450TT
	Ørn	2	23, 24	Ørn, Ravn	1905		73t, 34.5x4.4x1.6m, 2b,1vte, 850hp, 23kts, 16p; 2x1-37/45, (1+1x1)-450TT
Grib	3	25-27	Grib, Jo, Lom	1906		74t, 36.2x4.5x1.9m, 2b,1vte, 1000hp, 23kts, 16p; 2x1-37/45, (1+1x1)-450TT	
Teist	3	28	Teist	1908		103(28,29)-108(30)t, 41.1x4.7x2.3(28,29)-2.4(30)m, 2b,1vte, 1700hp, 25kts, 21p; 1x1-76/28(30), 2x1-47/46(28,29), (1+2x1)-450TT(28,29), (1+1x1)-450TT(30)	
		29	Skarv	1908			
		30	Kjell	1913			

## SUBMARINES

SS	Kobben	1	1	Kobben	1909		206/259t, 39.3x3.7x3.0m, 2d/em, 440/250hp, 11.9/8.9kts, 14p, 30m; 3-450TT
	A2	3	2	A2	1914		268/342t, 46.5x4.8x2.7m, 2d/em, 700/380hp, 14.5/9kts, 17p, 50m; 3-450TT
			3	A3	1914		
			4	A4	1914		

## OTHER FIGHTING SHIPS

PG	Ellida	1	1	Ellida	1882	No picture	1045t, 58.0x9.9x4.4m, 2vc, 900hp, 10.5kts, 130p; 2x1-76/40, 1x1-75/52, 2x1-65/50, 2x1-37/45
	Æger	1	2	Æger	1894		413t, 33.2x8.8x2.4m, 2b,2vte, 350hp, 9kts, 43p; 38deck; 1x1-209/35, 1x1-65/50, 2x1-47/40
	Orkla	2	3	Orkla	1917	No picture	270t, 38.0x7.0x1.7m, 360hp, 10kts; 2x1-120/48
4			Rauma	1917			

## MINE WARFARE SHIPS

ML	Vale	2	1	Vale	1874		250t, 27.3x7.9x2.2m, 2b,2vc, 200hp, 8kts, 38p; 1x1-120/44, 50mines
			2	Uller	1877		
	Brage	2	3	Brage	1879		270t, 28.9x7.9x2.2m, 2b,2vc, 220hp, 8.5kts, 38p; 1x1-149/45, 1x1-47/46, 50mines
			4	Nor	1879		
	Vidar	1	5	Vidar	1882		270t, 28.9x7.9x2.2m, 2b,2vc, 330hp, 9.5kts, 38p; 1x1-149/45, 1x1-47/46, 50mines
	Gor	2	6	Gor	1885		290(6)-278(7)t, 31.3x8.5x2.2m, 2b,2vc, 420hp, 10.5kts, 44p; 1x1-120/44, 1x1-57/40(7), 1x1-37/20(6), 2x5-37/17, 1-356TT, 55mines
			7	Tyr	1887		
	Frøya	1	8	Frøya	1917		755t, 75.6x8.2x2.8m, 2b,2vte, 7000hp, 21.8kts, 78p; 4x1-102/37, 1x2-450TT, 180mines
	Glommen	2	9	Glommen	1917	No picture	380t, 42.0x8.5x2.1m, 1b,1vte, 170hp, 9.8kts, 35p; 2x1-76/28, 120mines
			10	Laugen	1918		

## FISHERY PROTECTION VESSELS

FPV	Heimdal	1	1	Heimdal	1892	No picture	640t; 4x1-76/40
	Michael Sars	1	2	Michael Sars	1900	No picture	226t



© Ivan Gogin, 2014

[home](#)

[World navies yesterday](#)

[1920](#)

## Paraguay 01 January 1920

### OTHER FIGHTING SHIPS

APGR	-	2	1	Capitán Cabral	1907		206t; 1x1-76/40
			2	Tacuari	1910		150t; 2x1-76/50, 2x1-76/40

© Ivan Gogin, 2015

[home](#)[World navies yesterday](#)[1920](#)

## Persia 01 January 1920

### OTHER FIGHTING SHIPS

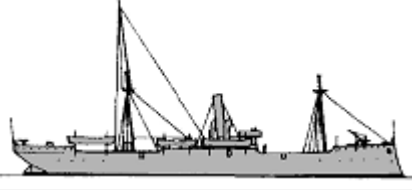
PG	Persepolis	1	1	Persepolis	1885		1200t, 63.1x10.0x5.9m, 1vte, 450hp, 10kts; 1x1-102/27, 1x1-95/19, 2x1-37/40
	Muzaffer	1	2	Muzaffer	1899	No picture	379t, 41.1x7.9x4.0m
PGR	Azerbaijan	1	1	Azerbaijan	1900s	No picture	
	Perebonia	1	2	Perebonia	1900s	No picture	

© Ivan Gogin, 2015

[home](#)[World navies yesterday](#)[1920](#)

## Peru 01 January 1920

### CRUISERS

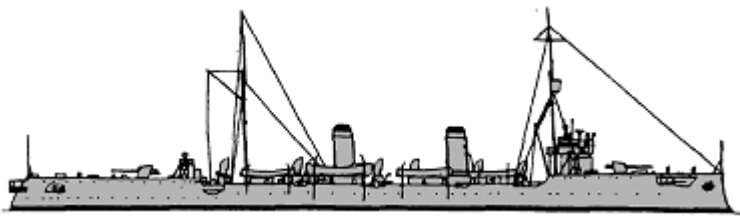
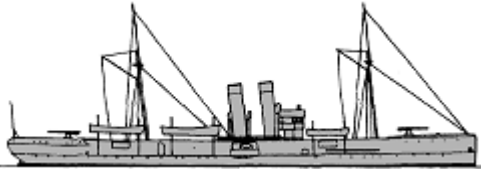
CL	Almirante Grau	1	Almirante Grau	1907		4877t, 115.8x12.3x4.3m, 10b,2vte, 14000hp, 24kts, 320p; 38belt, 38deck, 76shields, 76CT; 2x1-152/50, 8x1-76/40, 6x1-57/40, 2x1-37/20, 2-450TT	
		2	Coronel Bolognesi	1907			
CLL	Lima	1	1	Lima	1888		1790t, 76.2x10.7x4.6m, 4b,2hc, 1800hp, 16.2kts, 150p; 2x1-152/26, 3x1-47/40

### TORPEDO SHIPS

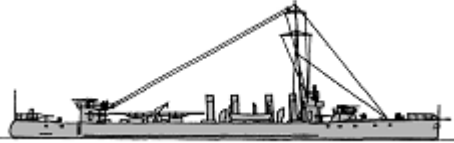
DD	Teniente Rodríguez	1	1	Teniente Rodríguez	1911		520t, 64.6ppx6.5x3.1m, 4b,3st, 8600hp, 28kts, 79p; 6x1-65/50, (1+2x1)-450TT
----	--------------------	---	---	--------------------	------	--	---

### OTHER FIGHTING SHIPS

PG	Santa Rosa	1	1	Santa Rosa	1883	No picture	2x1-152/26
PGR	Iquitos	1	1	Iquitos	1875	No picture	50t, 23.4x3.7x1.2m, 7.5kts; 1x1-47/40
	América	1	2	América	1904	No picture	240t, 40.5x5.9x1.4m, 2b,2vte, 350hp, 14kts, 26p; 4x1-47/40

© Ivan Gogin, 2015



[home](#)[World navies yesterday](#)[1920](#)

# Portugal 01 January 1920

## BATTLESHIPS

BC	Vasco da Gama	1	1	Vasco da Gama	1876		3200t, 70.9ppx12.2x6.3m, 2vte, 15.5kts, 260p; steel- 250belt, 75deck, 200shields; 2x1-203/40, 1x1-152/45, 1x1-76/40, 6x1-47/40
----	---------------	---	---	---------------	------	--	--

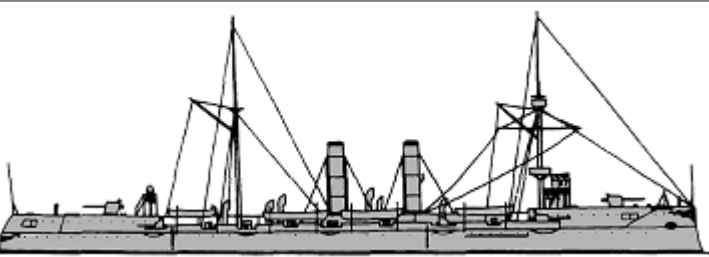
## CRUISERS

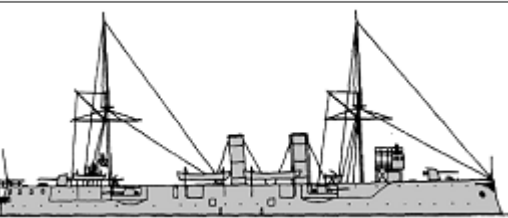
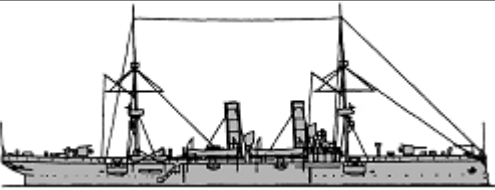
	Dom Carlos I	1	1	Almirante Reis	1898		4253t, 117.0x14.4x5.3m, 12b,2vte, 12500hp, 22kts, 473p; 110slopes, 37deck, 102CT; 4x1-152/45, 8x1-120/44, 14x1-47/40, 2x1-37/25, 2-356TT
CL	São Gabriel	1	2	São Gabriel	1899		1771t, 75.0x10.8x4.3m, 4b,2vte, 4000hp, 17.5kts, 242p; 20deck, 60CT; 2x1-149/45, 4x1-120/45, 8x1-47/40, 2x1-37/20, 1-356TT
	Rainha Dona Amélia	1	3	República	1901		1630t, 75.0ppx11.8x4.5m, 4b,2vte, 5000hp, 20kts, 273p; 30deck; 4x1-149/45, 2x1-100/45, 2x1-47/40, 2x1-37/25, 2-356TT
CLL	Adamastor	1	1	Adamastor	1897		1757t, 74.0ppx10.7x4.7m, 4b,2vte, 4000hp, 18kts, 237p; 30deck, 65CT; 2x1-149/27, 4x1-105/37, 4x1-65/40, 2x1-37/25, 3-356TT
				Pedro			

AMC	-	1	1	Nunes	1889		5486t, 110.8ppx12.8x6.4m, 1vte, 3600hp, 16kts; 2x1-120/40, 2x1-76/40, 2x1-47/40
-----	---	---	---	-------	------	--	---

## TORPEDO SHIPS

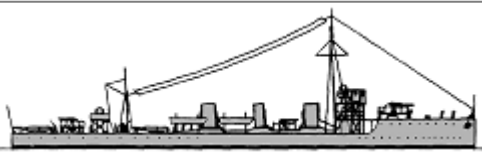
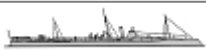
DD	Tejo	1	1	Tejo	1904		522t, 70.0x7.0x2.5m, 4b,2vte, 7000hp, 25kts, 85p; 1x1-100/44, 1x1-76/40, 2x1-47/40, 2x1-356TT
	Douro	2	2	Douro	1913		660t, 73.2x7.2x2.3m, 3b,2st, 11000hp, 27kts, 80p; 1x1-100/44, 2x1-76/40, 2x2-450TT
3			Guadiana	1915			
TB	Nº2	2	1, 2	Nº2, 3	1886		65t, 36.5ppx3.9x1.0m, 1b,1vc, 700hp, 19kts; 2x5-37/17, 2-356TT

## SUBMARINES





SS	Espadarte	1	1	Espadarte	1913	No picture	245/300t, 45.1x4.2x2.9m, 2d/em, 550/300hp, 13.8/8kts, 21p; 2-450TT
	Foca	3	2	Foca	1917		262/382t, 45.6x4.2x3.1m, 2d/em, 550/400hp, 14.2/8.2kts, 21p, 40m; 2-450TT
			3	Golfinho	1917		
			4	Hidra	1917		

## ESCORTS

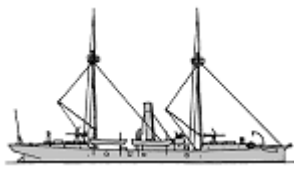
PC	Dili	1	1	Dili	1911	No picture	500t, 42.7ppx7.6x3.1m, 1vc, 500hp, 11kts, 72p
	Lince	1	2	Lince	1911	No picture	77t, 27.0ppx4.3x1.8m, 2d, 300hp, 12kts, 20p
	Carregado	1	3	Carregado	1912	No picture	105t, 24.4ppx5.5xm, 1vte, 300hp
APC	-	1	1	Cinco de Outubro	1900		1343t, 69.2x8.8x4.3m, 6b,2vte, 1800hp, 15kts; 2x1-47/40, 4x1-37/20

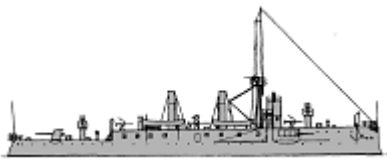
## OTHER FIGHTING SHIPS

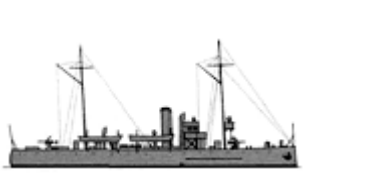
	Rio Tâmega	1	1	Rio Sado	1875	No picture	635t, 45.4ppx8.6x3.2m, 500hp, 11kts, 109p; 2x1-105/32, 2x1-65/40, 1x1-37/20
	Zambeze	1	2	Zambeze	1886	No picture	631t, 43.6ppx7.9x3.3m, 460hp, 10kts, 113p; 3x1-100/27, 1x1-37/20
	Limpopo	1	3	Limpopo	1890	No picture	288t, 37.8x6.4x2.0m, 1b,1vc, 520hp, 11.3kts, 42p; 2x1-47/40
	Chaimite	1	4	Chaimite	1898		341t, 41.0ppx8.0x2.0m, 2vte, 480hp, 11kts, 26p; 2x1-47/40

PG	Pátria	1	5	Pátria	1905		626t, 60.0ppx8.3x2.5m, 4b,2vte, 1800hp, 16.7kts, 95p; 12deck; 4x1-100/45, 6x1-47/40
	Lúrio	2	6	Lúrio	1907		305t, 42.8x7.2x1.8m, 2b,2vte, 500hp, 12.5kts, 51p; 2x1-47/40
			7	Save	1908		
	Beira	5	8	Beira	1910		492t, 45.0x8.3x2.1m, 2b,2vte, 700hp, 13kts, 51p; 1x1-87/21(8,11), 1x1-76/40(9,10), 2x1-76/40(12), 1x1-65/40(8), 2x1-57/40(9,10), 2x1-47/40(8-10), 4x1-47/40(11)
			9	Ibo	1911		
			10	Mandovi	1917		
			11	Bengo	1917		
12			Quanza	1917			
APG	-	1	1	Açor	1874		330t
PR	Pedro d'Annaia	1	1	Diogo Cão	1895	No picture	93t, 30.0ppx6.0x0.8m, 500hp, 9kts; 2x1-47/40
	Infante D. Manuel	1	2	Rio Minho	1904	No picture	38t, 24.6x4.0x0.6m, 1b,1vte(sw), 64hp, 7.5kts, 8p; 2x1-37/20
	Flecha	1	3	Flecha	1909	No picture	44t, 21.0x4.0x0.7m, 1b,1vte(sw), 45hp, 10kts, 7p; 1x1-37/20
	Macau	1	4	Macau	1910		133t, 36.5x6.0x0.7m, 1b,2vte, 250hp, 11.8kts, 24p; 2x1-57/40

## MINE WARFARE SHIPS

ML	Vulcano	1	1	Vulcano	1910		151t, 33.5x5.9x1.3m, 1b,2vte, 412hp, 12kts, 24p; mines
----	---------	---	---	---------	------	--	--

© Ivan Gogin, 2014



[home](#)[World navies yesterday](#)[1920](#)

# Romania 01 January 1920

## TORPEDO SHIPS

TBR	Căpitan Nicolae Lascăr Bogdan	7	1-7	Major Ene Constantin, Căpitan Nicolae Lascăr Bogdan, Căpitan Romani Michail, Major Giurascu Dimitrie, Major Sontu Gheorge, Major Grigore Ioan, Locotenent Calinescu Dimitrie	1906-1907		51t, 30.4x4.0x0.8m, 2b,2vce, 550hp, 18kts, 20p; 1x1-47/40, 2spar torpedoes
-----	-------------------------------	---	-----	--	-----------	---	--

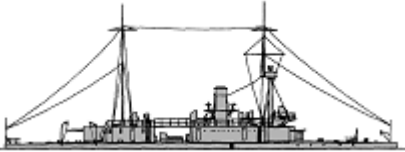
## OTHER FIGHTING SHIPS

RMON	Ion C. Brătianu	4	1	Ion C. Brătianu	1907		750t, 63.5x10.5x1.8m, 2b,2vte, 1800hp, 13kts, 110p; 70belt, 70deck, 75turrets, 75CT; 3x1-120/33, 2x1-120/8, 4x1-47/40
			2	Lascar Catargiu	1907		
			3	Alexandru Lachovari	1908		
			4	Mihail Kogălniceanu	1907		
FBR	MR491	6	1	MR491	1916		255t, 54.7x7.1x1.2m, 2sd, 100hp, 5.5kts; 1x1-152/44(4-6), 2x1-120/44(1-3)
			2	MR492	1916		
			3	MR493	1916		
			4	MR494	1916		
			5	MR495	1916		
			6	MR496	1916		

© Ivan Gogin, 2015



[home](#)[World navies yesterday](#)[1920](#)

# Russia 01 January 1920

## BATTLESHIPS

						9790t, 103.5x19.0x8.3m, 12b,2vc, 5500hp, 12.9kts, 440p; iron-356belt, 76deck; 4x1-203/49, 12x1-152/44, 12x1-75/48, 4x1-57/40, 8x1-47/40, 2x1-37/20
						10010t, 105.6x20.4x7.8m, 12b,2vc, 8500hp, 15.3kts, 616p; compound- 356belt, 63deck, 254barbette, 254CT; 1x2-305/27, 5x1-203/43, 8x1-152/44, 1x1-75/48, 4x1-63/17, 8x1-47/40
BB						13110t, 118.5x23.2x7.9m, 20b,2vte, 16300hp, 18kts, 779p; 250belt, 90deck, 250turrets, 254CT; 2x2-305/38, 6x2-152/44, 10x1-75/48, 4x1-47/40, 2x1-37/30, 4-381TT
						18580t, 140.2x24.4x8.5m, 25b,2vte, 17600hp, 18kts, 957p; 216belt, 89deck, 254turrets, 203CT; 2x2-305/38, (4x2+6x1)-203/49, 12x1-120/43, 2-450TT

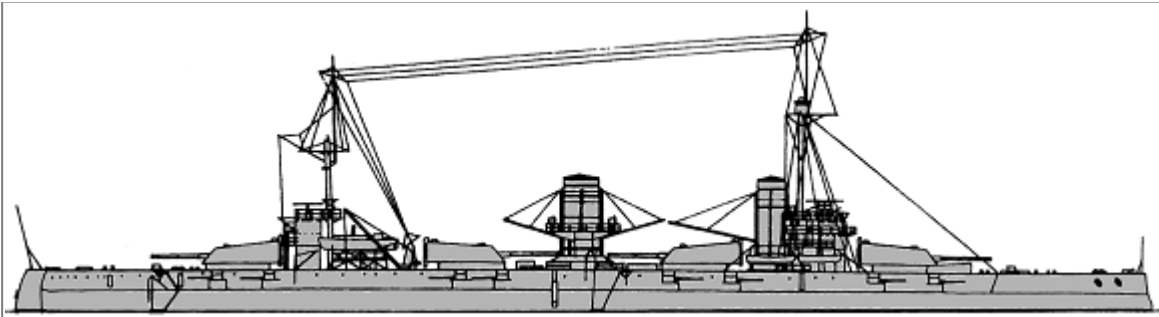
Sevastopol	3	6	Gangut	1914		26900t, 181.2x26.9x8.4m, 25b,4st, 42000hp, 23kts, 1140p; 225belt, 75deck, 305turrets, 250CT; 4x3-305/50, 15x1-120/49, 2x1-75/48(7), 2x1-63/36(6,8), 1x1-47/40(6,8), 1x1-40/39(7), 4- 450TT
		7	Sevastopol	1914		
		8	Petropavlovsk	1915		



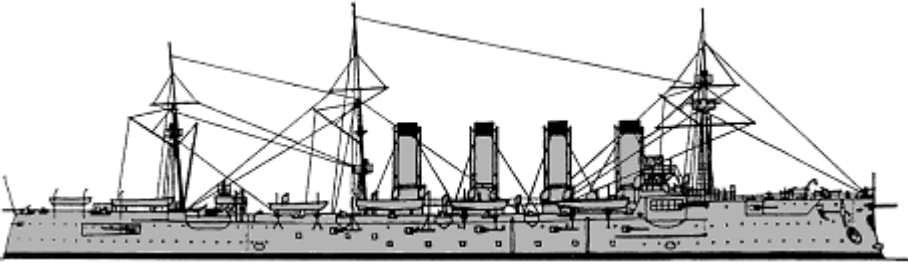
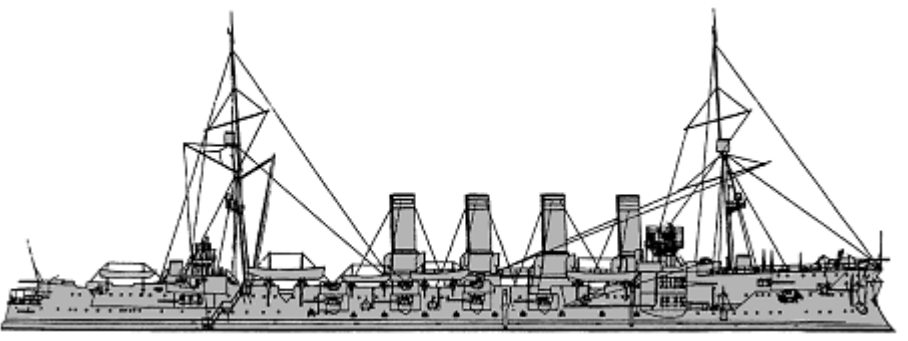
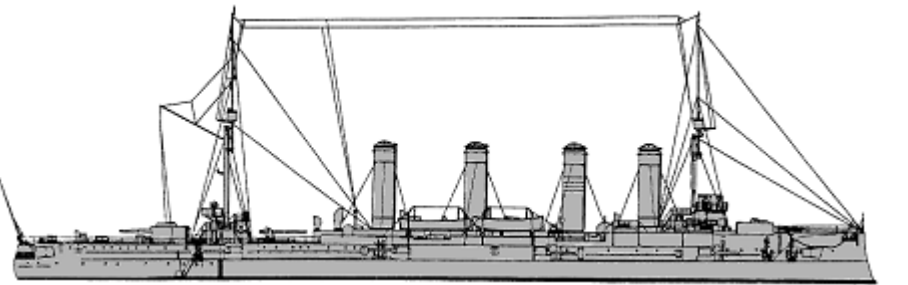
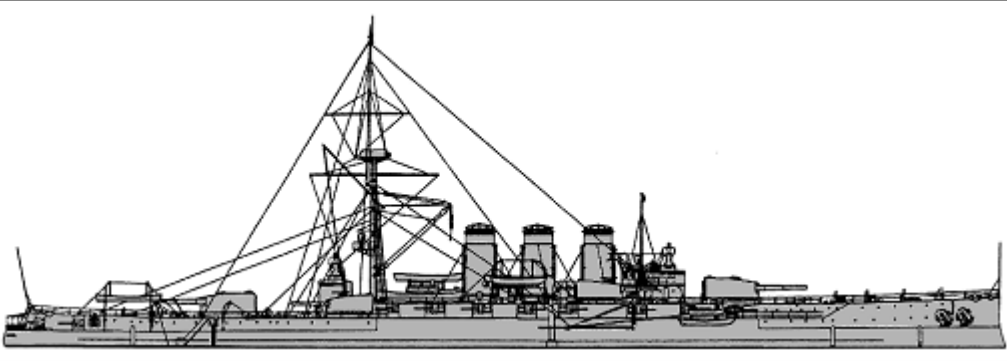

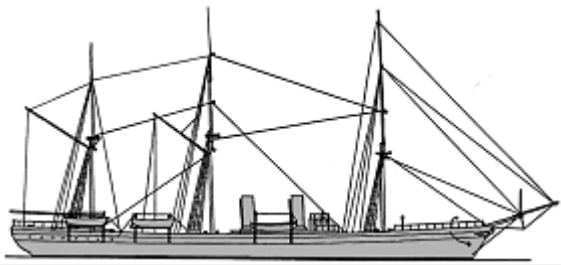
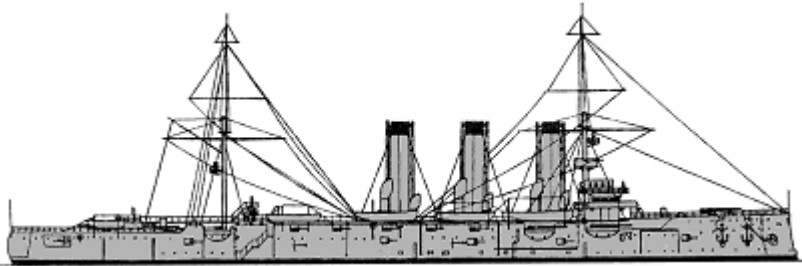
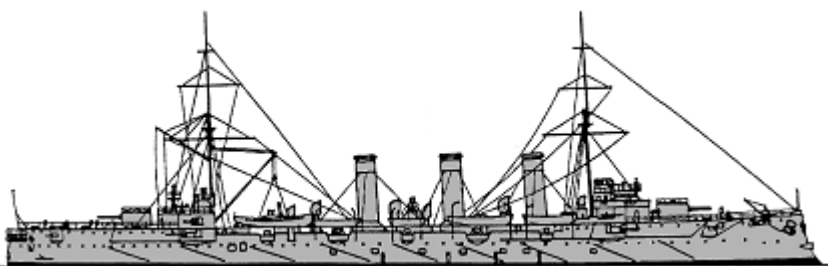
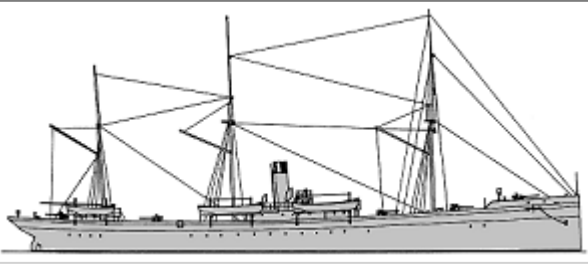
CRUISERS

CA	Rossiia	1	1	Rossiia	1897		12195t, 147.8x20.9x7.9m, 32b,2vte, 14500hp, 20.4kts, 839p; Harvey- 203belt, 76deck, 127casemates, 305CT; 6x1-203/49, 14x1-152/44, 2x1-47/40, 300mines
	Gromoboy	1	2	Gromoboy	1899		12455t, 146.6x20.9x7.9m, 32b,3vte, 14500hp, 19kts, 874p; 152belt, 76deck, 127casemates, 305CT; 8x1-203/43, 20x1-152/44, 4x1-75/48, 4x1-47/40, 2- 450TT, 200mines
	Bayan	2	3	Admiral Makarov	1908		8250t, 138.8(3)-137.0(4)x17.5x6.6m, 26b,2vte, 16500hp, 21kts, 573p; 175belt, 30deck, 132turrets, 136CT; 3x1-203/43, 12x1-152/44, 2x1-75/48, 2-450TT
			4	Bayan	1911		
Ryurik	1	5	Ryurik	1909		17880t, 161.2x22.9x8.7m, 28b,2vte, 19700hp, 21kts, 950p; 152belt, 76deck, 203turrets, 203CT; 2x2-254/49, 4x2-203/49, 20x1-120/49, 2x1-47/40, 1x1- 40/39, 2-450TT	

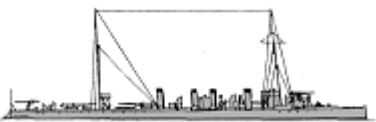

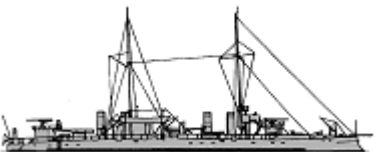
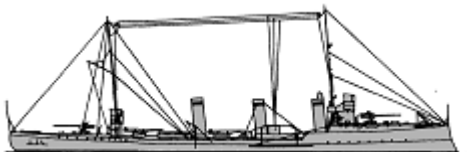

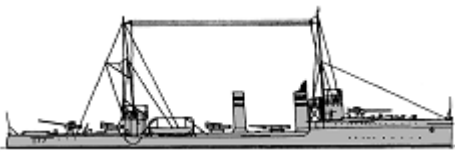

CL	Vityaz	1	1	Rynda	1886		3537t, 79.4x13.7x5.3m, 10b,1hc, 3000hp, 11.5kts, 396p; steel- 38deck; 4x1-75/48, 4x1-47/40
	Pallada	2	2	Diana	1901		6932(2)-6897(3)t, 126.8x16.8x6.5m, 24b,3vte, 11610hp, 19.2kts, 570p; NS-63slopes, 38deck, 25(3)shields, 152CT; 14x1-152/44(3), 10x1-130/53(2), 2x1-75/48(2), 1x1-75/48(3), 126mines
			3	Avrora	1903		
Bogatyr	1	4	Bogatyr	1902		6700t, 134.0x16.6x6.3m, 16b,2vte, 19500hp, 23kts, 581p; 70slopes, 35deck, 125turrets, 140CT; (2x2+12x1)-130/53, 2-381TT, 150mines	
AMC -		7	1	Afrika	1878		2590t, 90.2x10.9xm, 1417hp, 12.8kts; 5x1-152/23, 4x1-107/17, 2x1-87/21
			2	Oryol	1909		3554brt, 102.6x13.8m, 4200hp, 10kts; 2x1-120/43, 2x1-75/48, 4x1-47/40
			3	Roza Lyuksemburg	1897		1260t, 55.5x9.1x3.4m, 480hp, 9kts; 2x1-130/53
			4	Ilyich	1894		1051brt, 76.2x8.5x3.7m, 750hp, 10kts; 4x1-102/60, 1x1-75/48
			5	III Internatsional	1908		3636t, 108.4x14.0x7.6m, 1000hp, 10kts; 5x1-130/53, 2x1-75/48, 2x1-47/40
			6	Kolomna	1888		1147brt, 77.0x10.6x3.7m, 800hp, 9.5kts; 4x1-102/60, 2x1-76/28
			7	Makarov I	1898		252t; 2x1-102/60

## TORPEDO SHIPS

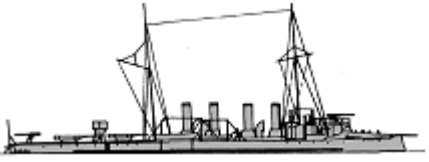
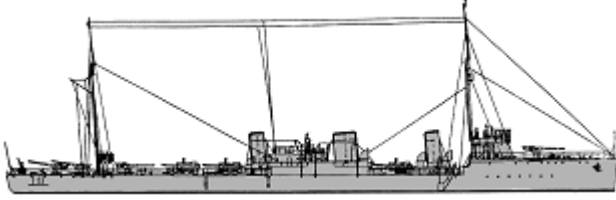
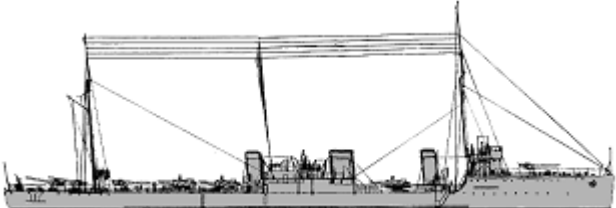
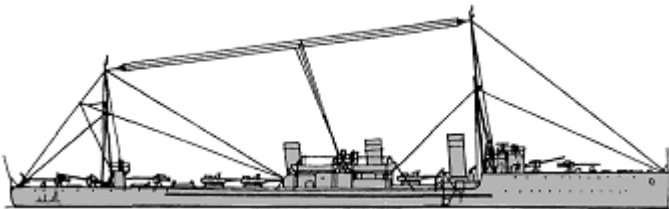
Sokol	1	1	Prytkiy	1895		240t, 57.9x5.6x2.3m, 8b,2vte, 3800hp, 29kts, 54p; 2x1-75/48, 2x1-450TT, 10mines, sweeps
Krechet	3	2	Prochny	1902		305t, 57.9-61.0x5.6-5.7x2.3-2.4m, 8b,2vte(2,3)-4b,2vte(4), 3800hp, 26.5-27.5kts, 51-58p; 2x1-75/48, 2x1-450TT(3), 10mines, sweeps(2,4)
		3	Porazhayushchiy	1902		
		4	Retivy	1902		







Boykiy	2	5	Vidny	1905		520-530t, 64.0x6.4x2.4-2.5m, 4b,2vte, 5700hp, 26kts, 69p; 2x1-75/48, 2x1-450TT, 18mines
		6	Gromyashchiy	1905		
Leytenant Burakov	8	7	Metkiy	1906		492t, 56.5x6.4x3.5m, 4b,2vte, 5700hp, 27kts, 67p; 2x1-75/48, 2x1-450TT, 10mines
		8	Iskusny	1906		
		9	Krepkiy	1906		
		10	Molodetskiy	1906		
		11	Lyogkiy	1906		
		12	Moshchny	1905		
		13	Lovkiy	1906		
14	Likhoy	1906				
Ukrayna	7	15	Ukrayna	1905		880t, 73.2x7.2x3.4m, 4b,2vte, 7000hp, 26kts, 88p; 3x1-102/60, 2x1-102/60(19,21), 1x1-40/39(15-18,20), 1x1-37/20, 2x1-450TT, 25mines(15-17), 16mines(18-21)
		16	Voyskovoy	1905		
		17	Turkmenets-Stavropolskiy	1905		
		18	Steregushchiy	1906		
		19	Strashny	1906		
		20	Donskoy Kazak	1906		
		21	Zabaykalets	1907		
Emir Bukharskiy	2	22	Emir Bukharskiy	1905		720t, 71.9x7.2x2.7m, 4b,2vte, 6500hp, 25kts, 99p; 2x1-102/60, 2x1-37/20(22), 1x1-37/20(23), 3x1-450TT, 20mines
		23	Finn	1906		
Inzhener-Mekhanik Zverev	7	24	Inzhener-Mekhanik Zverev	1906		540t, 63.6x7.0x2.7m, 4b,2vte, 6000hp, 27kts, 65p; 2x1-75/48, 3x1-450TT, 16mines
		25	Inzhener-Mekhanik Dmitriev	1906		
		26	Boevoy	1906		
		27	Burny	1906		
		28	Vnimatelny	1906		
		29	Vnushitelny	1906		
		30	Vynoslivy	1906		
Vsadnik	4	31	Vsadnik	1906		930t, 71.9x7.2x2.4m, 4b,2vte, 6500hp, 25kts, 99p; 2x1-102/60, 1x1-37/20, 3x1-450TT, 25mines
		32	Gaydamak	1906		
		33	Amurets	1907		
		34	Ussuriets	1907		
General Kondratenko	3	35	General Kondratenko	1906		840t, 75.2x8.2x2.4m, 4b,2vte, 7300hp, 25.5kts, 102p; 3x1-102/60, 2x1-47/40(35), 3x1-450TT, 25mines
		36	Sibirskiy Strelok	1906		
		37	Pogranichnik	1906		
		38	Silny	1907		

DD

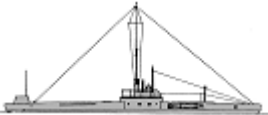

Silny	7	39	Storozhevoy	1907		475t, 64.0x6.4x2.6m, 4b,2vte, 5800hp, 27kts, 67p; 2x1-75/48, 2x1-450TT, 12mines
		40	Razyashchiy	1908		
		41	Rastoropny	1908		
		42	Delny	1907		
		43	Deyatelny	1907		
		44	Dostoyny	1907		
		Novik	1	45		
Pobeditel	5	46	Pobeditel	1915		1450t, 98.0x9.3x3.2m, 4b,2st, 30000hp, 35kts, 112p; 4x1-102/60, 1x1-76/28(47), 1x1-63/36(46), 1x1-40/39(48-50), 3x3-450TT, 80mines
		47	Zabiyaka	1915		
		48	Desna	1916		
		49	Azard	1916		
		50	Samson	1916		
Kapitan Izylmetyev	2	51	Kapitan Izylmetyev	1916		1450t, 98.0x9.3x3.9m, 4b,2st, 31500hp, 34kts, 150p; 4x1-102/60, 1x1-76/28(52), 1x1-40/39(51), 3x3-450TT, 80mines
		52	Garibaldi	1916		
Izjaslav	1	53	Izjaslav	1917		1570t, 107.0x9.5x4.1m, 5b,2st, 32700hp, 35kts, 150p; 5x1-102/60, 1x1-76/28, 3x3-450TT, 80mines
TB	1	1	Okhotnik	1883		63t, 38.0x3.1x2.0m, 1b,1vc, 575hp, 18.5kts, 18p; 1x1-47/40, 2x1-37/20, 1x1-381TT
	1	2	Ilim	1886		76t, 38.5x4.5x1.9m, 1b,1vc, 640hp, 19.3-20kts, 21p; 2x1-47/40, 2x5-37/17
	1	3	Periskop	1892		101-105t, 46.5-46.8x3.9x2.3-2.6m, 1b,1vte, 1000-1030hp, 16.2-19kts, 21p; 1x1-75/48, 1x1-47/40, 1x1-37/20
	1	4	No115	1893		85-87t, 38.7x4.6x2.0m, 1b,1vte, 1000hp, 20kts, 21p; 2x5-47/22, (1+1x1)-381TT
	1	5	No142	1897		120t, 42.0x4.5x2.1m, 2b,2vte, 2000hp, 19.5-23.2kts, 21p; 2x1-47/40, 2x5-37/17
	1	6	No213	1902		204t, 53.5x5.3x1.6m, 4b,2vte, 3800hp, 24kts, 26p; 2x1-47/40, sweeps

Lastochka	1	7	Lastochka	1905		140t, 46.5x4.7x1.5m, 2b,2st+1vte, 2250hp, 26.4kts, 23p; 1x1-75/48, 1x1-47/40
-----------	---	---	-----------	------	---	--

## SUBMARINES

Kasatka	4	1	Kasatka	1905		142/177t, 33.4x3.4x2.8m, 1peg,1em(1,4)-1d/em(2)-1dg,1em(3), 100(1,4)-120/100(2,3)hp, 14/8.5(1,3,4)-9/5(2)kts, 24p, 50m; 4-450TT
		2	Makrel	1908		
		3	Okun	1908		
		4	Keta	1905		
Minoga	1	5	Minoga	1909		123/152t, 32.6x2.8x2.7m, 1d/em, 240/70hp, 10/5.2kts, 22p, 45m; 1x1-37/20, 2-450TT
Kayman	1	6	Alligator	1909		409/482t, 40.8x3.9x4.9m, 2pe/em, 800/400hp, 9/7kts, 34p, 50m; 1x1-47/40, 6-450TT
SS Bars	11	7	Vepr	1915		670/810t, 68.0x4.5x4.3m, 2d/em, 500/900(7-13,16,17)-2640/900(14)-840/900(15)hp, 12.5/9.5(7-13,16,17)-17.6/8.7(14)-11.6/9.5(15)kts, 44p, 50m; 1x1-75/48(7-11,13,15-17), 1x1-57/40(8-17), 1x1-37/20(7-11,13,15-17), 4-450TT(7), 12-450TT(8-16), 8-450TT(17)
		8	Tigr	1916		
		9	Volk	1916		
		10	Pantera	1916		
		11	Rys	1916		
		12	Kuguar	1917		
		13	Leopard	1917		
		14	Zmeya	1917		
		15	Ugor	1917		
		16	Tur	1917		
17	Yaguar	1917				
Yorsh	1	18	Yorsh	1917		655/750t, 68.0x4.5x4.3m, 2d/em, 840/900hp, 10.7/7.5kts, 44p, 50m; 1x1-57/40, 1x1-37/20, 2-450TT, 42mines
Svyatoy Georgiy	1	19	Svyatoy Georgiy	1917		260/305t, 41.2x4.3x3.1m, 2d/em, 700/500hp, 13/8.5kts, 27p, 30m; 1x1-75/48, 2-450TT

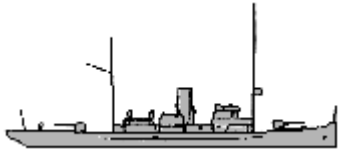
## ESCORTS

FS	Kopchik	2	1	Kopchik	1916		550t, 51.2x7.3x2.9m, 3b,2vte, 1500hp, 15kts, 57p; 2x1-105/42, 1x1-40/39, 70mines
			2	Korshun	1916		
PC	Dozorny	2	1	Dozorny	1905		100t, 30.8x5.0x1.7m, 2b,1vte, 660hp, 16kts, 31p; 1x1-37/20, sweeps
			2	Razvedchik	1905		
				3	Kunitsa	1916	
				4	Sobol	1916	

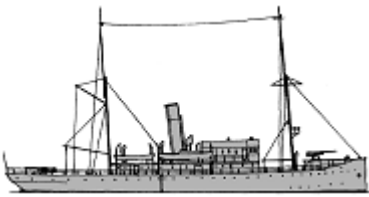
	Barsuk	6	5	Gornostay	1916		202t, 30.5x5.8x2.7m, 1b,1vte, 350hp, 11kts, 46p; 2x1-75/48, 1x1-37/20
			6	Laska	1916		
			7	Khoryok	1916		
			8	Vydra	1916		
ADV	-	17	1	Izhora	1913		210t
			2	Zarnitsa	1891		1086brt, 79.2x11.4m, 2400hp, 14.7kts; 3x1-47/40
			3	Krechet	1898		2844t, 85.8x11.6m, 2600hp, 13.5kts
			4	Ruslan	1914		350t; 1x1-75/48
			5	Polyarnaya Zvezda	1891		3949t, 106.5x13.8x5.2m, 6000hp, 17kts; 4x1-47/40
			6	Shtandart	1896		5557t, 112.8x15.4x6.6m, 12000hp, 20kts; 8x1-47/40
			7	Aleksandriya	1896		544t; 4x1-87/27
			8	Artillerist	1914		238t
			9	Astarta	1899		220t
			10	Boykiy	1916		820t
			11	Kopanets	1913		180t
			12	Minyor	1892		320t
			13	Molniya	1910		320t
			14	Neva	1906		507t
			15	Nevka	1905		140t
			16	Strela	1891		290t
			17	Chernomorskiy No4	1914		280t
APC	-	2	1	Voron	1896		1100t, 4.5x9.6x4.5m, 700hp, 10.3kts; 2x1-75/48
			2	Yastreb	1900		1150t, 57.9x8.8x4.9m, 1124hp, 12kts; 2x1-105/42
APCR	-	10	1	Olga	1889		
			2	Tatarin	1905		1x1-76/28
			3	Yaponets	1912		
			4	Chastnik	1901		141t; 1x1-75/48
			5	Borets	1907		140t; 1x1-76/17
			6	Robespyer	1916		145t; 1x1-75/48
			7	Lassal	1913		142t; 1x1-75/48
			8	Sotsialist	1894		235t; 1x1-75/48
			9	Chudarev	1901		103t
			10	Krechet	1914		
			1	Bakinets	1901		
			2	Kreyser	1884		
			3	Tovarishch Petrov	1883		
			4	No3	1897		185t

ADVR	-	11	5	Zhelyabov	1911		499t
			6	Nekrasov	1906		390t
			7	Pinega	1915		160t
			8	Pushkin			515t
			9	Stenka Razin	1900		245t
			10	Trud	1914		130t
			11	Ust-Sysolsk	1912		203t

## OTHER FIGHTING SHIPS

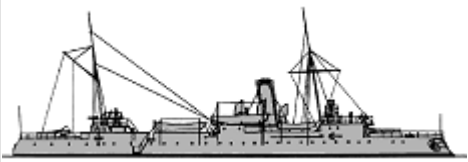
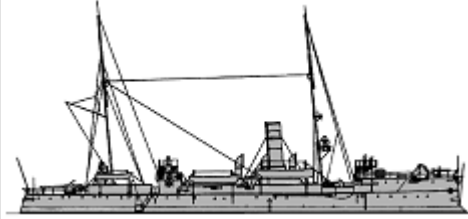
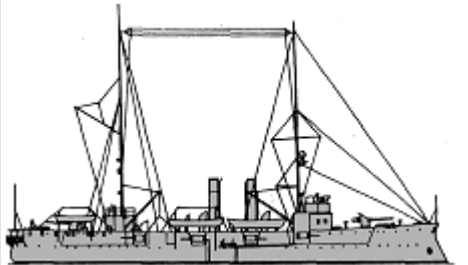
PG	Grozyashchiy	1	1	Grozyashchiy	1892		1627t, 72.3x12.7x4.0m, 6b,2vte, 2050hp, 14.5kts, 188p; steel- 127belt, 38deck, 25CT; 2x1-152/49, 2x1-75/48
	Khrabry	1	2	Khrabry	1897		2100t, 72.3x12.7x3.8m, 8b, 2vte, 2100hp, 14kts, 188p; 5x1-130/53, 11x1-47/40, 1-450TT, 20mines
	Khivinets	1	3	Khivinets	1906		1360t, 70.5x11.3x3.5m, 8b,2vte, 1400hp, 13.5kts, 161p; steel- 45CT; 4x1-120/43, 2x1-47/40
			1	Anarkhist	1870		747t; 3x1-76/28
			2	Bela Kun	1916		1x1-75/48
			3	Zhan Pol Marat	1903		2x1-102/60
			4	Vasiliy Testenev	1898		2x1-120/43
			5	Karamysh	1910		2x1-130/53, 1x1-76/28
			6	Kustar	1897		1x1-76/28
			7	Pobeditel	1883		2x1-76/28
			8	Priliv	1908		2x1-76/28
			9	Gnevny	1863		2x1-76/28
			10	Krasnoe Znamya	1915		2x1-102/60
			11	Vanya Kommunist	1911		3x1-102/60
			12	Volgar Dobrovolets	1916		373t; 2x1-120/43
			13	Besposhchadny	1899		3x1-102/60
			14	Klyovshchik	1912		203t; 4x1-75/48
			15	Kosnoy	1910		156t; 2x1-75/48



			16	Burny	1903		440t; 4x1-75/48
			17	Pamyat Volodarskogo	1899		387t; 2x1-102/60
			18	No109	1896		
			19	Avangard Revolyutsii	1898		445t; 2x1-120/43
			20	Burevestnik	1896		4x1-75/48
			21	Bedovy	1895		4x1-75/48
			22	Pronzitelny	1914		1x1-76/15
			23	Bditelny	1898		4x1-75/48
			24	Terrorist	1893		2x1-76/15
			25	Tovarishch	1907		188t; 3x1-75/48
			26	Tsyganov	1892		2x1-102/60
			27	No1			196t; 1x1-75/48
APGR -		55	28	Roza Lyuksemburg	1905		410t; 1x1-130/53, 1x1-120/43
			29	Kommunist	1903		120t; 2x1-75/48
			30	Volodarskiy	1903		195t; 2x1-75/48
			31	Pavlin Vinogradov	1906		500t; 2x1-102/60
			32	Karl Libknekht	1903		500t; 2x1-102/60
			33	Uritskiy	1903		174t; 2x1-75/48
			34	Geroykiy	1912		146t; 2x1-76/15
			35	Boevoy	1897		308t; 2x1-76/15
			36	Gordy	1904		345t; 2x1-76/28
			37	Goryachiy	1912		254t; 1x1-76/15
			38	Grozny	1908		189t; 2x1-76/28
			39	Grozyashchiy	1912		316t; 2x1-107/20
			40	Gromkiy	1916		203t; 1x1-76/15
			41	Gromovoy	1912		533t; 2x1-122/18
			42	Gubitelny			155t; 2x1-76/28
			43	Doroteya	1916		203t; 2x1-76/28
			44	Maly	1917		191t; 4x1-76/15
			45	Metkiy	1916		191t; 4x1-76/15
			46	Moguchiy	1887		177t; 2x1-130/53
			47	Molnienosny	1910		180t; 2x1-122/18
			48	Molodetskiy	1912		4x1-76/15
			49	Moscchny	1915		177t; 2x1-130/53
			50	Mstitelny	1911		200t; 2x1-130/53
			51	Mudry	1912		191t; 4x1-76/15
			52	Borets	1897		
			53	Velisa	1899		
			54	Dvinsk	1894		
			55	Toropa	1892		

APR	-	31	1	Bliznetsy	1904	
			2	Volodarskiy	1897	250t; 2x1-75/48
			3	Ekaterina	1912	
			4	Elizaveta	1887	
			5	Kaspiy	1914	3x1-102/60
			6	Kommunist	1897	370t; 1x1-102/60, 1x1-75/48
			7	Konstantin	1913	
			8	Krasnoarmeets	1883	2x1-76/28
			9	Lezgin	1910	3x1-76/28
			10	Mikhail I	1891	1x1-76/28
			11	Mikhail II	1899	1x1-76/28
			12	Moryak	1900	
			13	Roshal	1914	2x1-75/48
			14	Spartakovets	1904	2x1-75/48
			15	Smotritel	1891	
			16	Strazha	1891	
			17	Synovya	1899	
			18	Volya	1912	2x1-75/48
			19	Bednota	1912	2x1-75/48
			20	Mikhail Krutov	1899	
			21	Altfater	1913	747t; 3x1-102/60
			22	Karl Marks	1897	1x1-102/60, 2x1-76/28
			23	No108	1897	2x1-76/28
			24	No1	1913	180t
			25	No4	1912	250t; 1x1-75/48
			26	No4	1902	180t
			27	Zhan Zhores	1909	3x1-76/28
			28	Neoptolem	1863	3x1-76/28
			29	Tovarishch Markin	1888	2x1-76/28
			30	Turkestanets		1x1-75/48
			31	Yastreb	1897	150t
			1	No1	1915	107.5x17.2m; 2x1-152/44, 1x1-76/28
			2	No2	1913	123.8x16.3m; 2x1-152/44, 1x1-76/28, 1x1-37/20
			3	No3		110.8x14.6m; 2x1-152/44, 1x1-76/28
			4	No4	1914	103.6x15.2m; 2x1-152/44, 1x1-76/28, 1x1-37/20
			5	No5	1913	96.0x15.0m; 3x1-75/48
			6	No6	1888	74.0x11.1m
			7	Tsar-Devitsa	1915	107.8x17.2m; 2x1-130/53
			8	Ataman Razin	1914	1905t, 106.6x17.0m; 4x1-130/53
			9	Pamyat Tovarishcha Uritskogo	1918	875t; 4x1-130/53





AFBR -	23	10	No1			188t; 1x1-203/9, 1x1-76/15
		11	No2			188t; 1x1-203/9, 1x1-76/15
		12	No5	1902		265t; 1x1-75/48
		13	No3	1911		260t; 2x1-75/48
		14	No6	1904		225t; 1x1-76/28, 1x1-75/48
		15	Moskva			2x1-102/60
		16	Kronshtadt			2x1-102/60
		17	Petrograd			2x1-120/43
		18	Turkestan			2x1-152/44
		19	Vengriya			2x1-130/53
		20	Bavariya			2x1-130/53
		21	No8			
		22	No9			2x1-152/44
23	No10			2x1-152/44		

## COASTAL FORCES

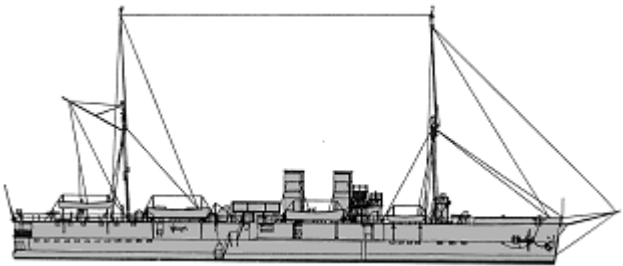
PT	No1	10	1-10	No1-10	1906		35t, 27.4x3.7x1.5m, 2pe, 600hp, 20kts, 11p; 1x1-47/40, 1x1-450TT
YP	No311	19	1-19	SK-3, 7, 8, 11, Bepokoyny, Bezrassudny, Bezzavetny, Bezzhalostny, Burny, Derzkiy, Pronzitelny, Pylkiy, Schastlivy, Smely, Zhutkiy, Zorkiy, No527	1916-1917		15-24t, 18.3-22.0x3.1-3.4x0.6-0.9m, 3pe, 525-1080hp, 21-30kts, 8p; 1x1-47/40, 1x1-37/20
	SK.1	4	20-23	No303-306	1916-1917		16t, 16.8x2.8x1.1m, 2pe, 250-300hp, 20-21kts, 15p; 1x1-47/40
	SK.13	11	24-34	SK.42-45, 47, 48, 50, 54-56, 58	1916-1917		16-20t, 17.2-21.2x2.8-3.2x1.1-1.4m, 2pe, 240-300hp, 15kts; 1x1-47/40
PR	Pulya	1	1, 2	Kopyo, Pika	1910		25t, 22.2x3.1x0.5m, 2pe, 200hp, 14.5kts, 12p; 8belt, 8deck, 8CT; 1x1-76/14
	K	9	3-11	No1, 2, 4, 5, 307-311	1917		25t, 20.4x3.2x0.6m, 2pe, 150hp, 12.5kts, 12p; 5belt, 4deck, 6turrets, 6CT; 2x1-76/16
	N	12	12-23	No1-7, 9-13	1916-1917		18t, 15.2x3.1x0.7m, 2pe, 100hp, 11.5kts, 8p; 7belt, 5deck, 7turret, 7CT; 1x1-76/16

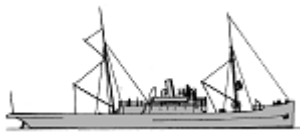
## MINE WARFARE SHIPS

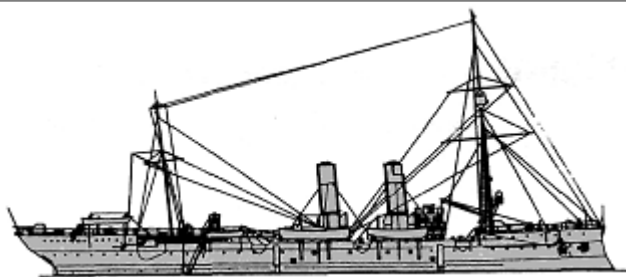
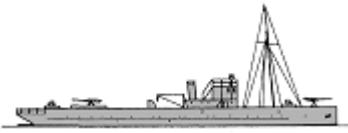
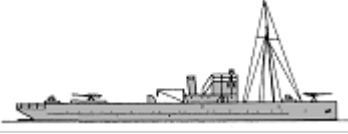
	General-Admiral	1	1	Narova	1875		5031t, 91.0x14.6x7.0m, 6b,1vc, 4470hp, 12.3kts, 490p; iron- 152belt, 25deck; 4x1-75/48, 8x1-37/20, 1-381TT, 600mines
	Zagraditel	1	2	Zagraditel	1906		459t, 46.3x7.3x3.1m, 2b,1vte, 480hp, 9.5kts, 33p; mines

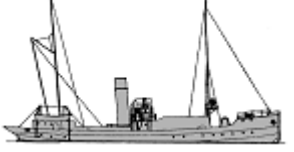
ML							
	Volga	1	3	Volga	1909		1711t, 70.3x11.9x4.4m, 4b,2vte, 1600hp, 13.5kts, 219p; 4x1-47/40, 230mines
	Amur	1	4	Amur	1909		2926t, 98.9x14.0x4.4m, 12b,2vte, 5000hp, 16kts, 312p; 5x1-120/43, 2x1-75/48, 320mines
AML	-	4	1	Lena	1899		2400t, 79.5x11.4m, 1500hp, 12kts; 4x1-75/48, 372mines
			2	Lovat	1912		1060t, 64.7x11.0m, 650hp, 9kts; 2x1-75/48, 360mines
			3	Terek	1884		1700t, 60.0x9.0m, 560hp, 10kts; 2x1-47/40, 300mines
			4	Ural	1912		2530t, 78.0x9.6m, 1555hp, 10kts; 2x1-75/48, 520mines
AMLR	-	3	1	Kalmyk	1907		
			2	Fridrikh Engels	1894		
			3	Sverdlov	1898		268t; 1x1-75/48
NL	Berezina	2	1	Berezina	1918	No picture	450t, 50.7x16.7x2.0m, 2d(sw), 600hp, 7.5kts, 47p; 2x1-75/48, 120mines, nets
	2		Yauza	1919			
	Kuban	1	3	Kuban	1918		330t, 51.4x7.6x1.3m, 2d, 500hp, 9kts, 67p; 2x1-102/60, 60mines, nets
Indigirka	1	4	Indigirka	1919		320t, 47.5x8.0x1.5m, 2d, 400hp, 8.5kts, 67p; 2x1-75/48, 60mines, nets	
ANL	-	1	1	Sheksna	1904		450t; 80mines
MS	Minrep	1	1	Zapal	1912		150t, 45.0x6.1x1.9m, 2b,2vde, 280hp, 11kts, 30p; 1x1-57/50, sweeps, 50mines
	Iskra	1	2	Patron	1914		420t, 44.5x7.5x3.3m, 1b,1vte, 650hp, 11.6kts, 49p; 2x1-75/48, sweeps, 45mines
			3	Udarnik	1917		

	Udarnik	2	4	Klyuz	1917		220t, 43.6x6.1x1.7m, 2b,2vte, 400hp, 11kts, 35p; 1x1-75/48, 1x1-47/40, sweeps
MSB	Chayka	1	1	Chayka	1911		24t, 15.5x3.7x1.2m, 1pe, 100hp, 9.5kts; 1x1-37/20, sweeps
AMS	-	6	1	Buksir			226t
			2	No24	1900		150t; 1x1-75/48, sweeps
			3	Garpun	1912		310t; 2x1-75/48, sweeps
			4	Nevod	1912		310t; 2x1-75/48, sweeps
			5	Yakor	1912		310t; 2x1-75/48, sweeps
			6	T-325	1897		783t; 1x1-120/43, sweeps
AMSR	-	36	1	Aviator	1905		
			2	Aleksey	1889		
			3	Zolotovich	1903		
			4	Kuropatkin	1898		
			5	Liliya	1900		
			6	Matvey	1904		
			7	Orlyonok	1896		
			8	Pravda	1901		
			9	Promyslovy	1904		
			10	Revizor	1903		
			11	Ryazhsk	1894		
			12	Skvorets	1905		
			13	Sotrudnik	1911		
			14	Terek	1913		
			15	Turkmen	1886		
			16	Etna	1904		
			17	Alyosha Popovich	1898		
			18	Attal	1900		
			19	Grigoriy	1898		
			20	Maksimilian	1870		
			21	Melnik	1862		
			22	Nadyozhny	1896		
			23	Perekat	1899		
			24	Predpriimchivy	1897		
			25	Saratovskiy Rupvod	1904		
			26	Burlak	1911		114t
			27	Vetluga	1913		175t
			28	Vozhak	1901		

29	Lotsman	1907		121t
30	Luch	1914		200t
31	Narym	1911		114t
32	Nolinsk	1896		158t
33	Perebor	1898		175t
34	Porog	1919		121t
35	Udachny	1914		114t
36	Shkval	1910		100t

## BOARD GUARD SHIPS

CG	Roksana	1	1	Roksana	1893	No picture	157t, 37.0x4.2x2.0m, 2b,1vte, 600hp, 12kts; 2x5-37/17, sweeps
----	---------	---	---	---------	------	------------	---





© Ivan Gogin, 2014

[home](#)[World navies yesterday](#)[1920](#)

## Siam 01 January 1920

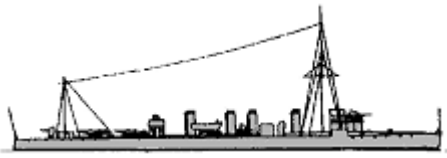
### TORPEDO SHIPS

DD	Sua Tayanchon	2	1	Sua Tayanchon	1908		385t, 69.2ppx6.6x1.8m, 4b,2vte, 6000hp, 27kts, 75p; 1x1-76/40, 5x1-57/40, 2x1-450TT
			2	Sua Khamronsin	1912		
TB	No1	4	1	No1	1908		100t, 41.1x4.9x2.1m, 2b,1vte, 1200hp, 23kts, 29p; 1x1-57/40, 1x1-47/40, 2x1-450TT
			2	No2	1908		
			3	No3	1908		
			4	No4	1913		

### OTHER FIGHTING SHIPS

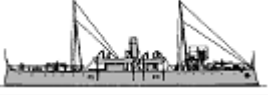
PG	Mongkut Rajakumarn	1	1	Mongkut Rajakumarn	1887	No picture	700t, 53.3x7.2x3.4m, 2b,2vte, 800hp, 14kts, 100p; 2x1-120/40, 4x1-57/40, 3x1-37/20, 1-356TT
	Muratha	3	2	Muratha	1898		530(2)-580(3,4)t, 44.2(2)-49.4(3,4)x7.0x3.1m, 2b,2vte, 500hp, 11.4kts, 83p; 1x1-120/40, 5x1-57/40, 4x1-37/20
			3	Bali	1900		
			4	Sugrib	1901		
	Sri Monthon	1	5	Sri Monthon	1908		225t, 41.8x5.5x2.0m, 1b,2vte, 7500hp, 14.5kts, 34p; 2x1-57/40
DV	Prap Porapak	1	1	Prap Porapak	1898	No picture	210t

© Ivan Gogin, 2015

[home](#)[World navies yesterday](#)[1920](#)

# Spain 01 January 1920

## BATTLESHIPS

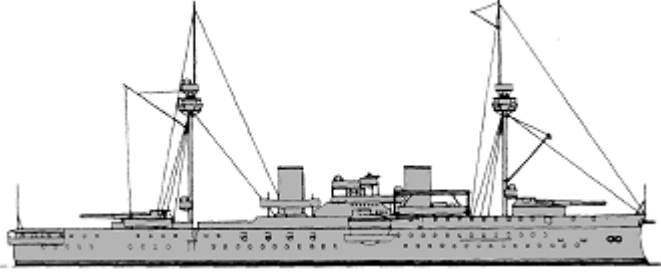
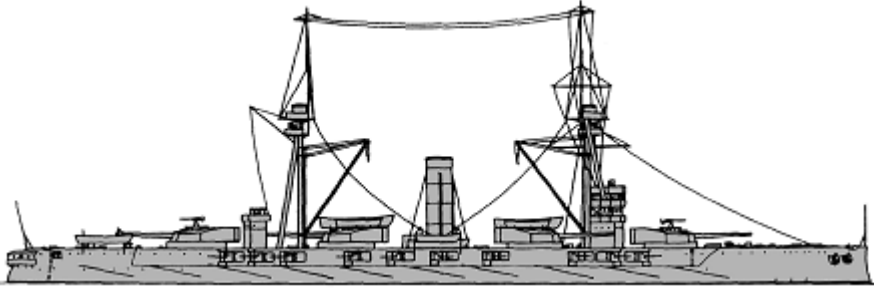
BB	Pelayo	1	1	Pelayo	1888		9950t, 105.1x20.2x7.6m, 16b,2vc, 9473hp, 16kts, 520p; steel- 450belt, 70deck, 400barbettes, 155CT; 2x1-320/35, 2x1-280/35, 9x1-140/36, 5x1-57/42, 14x1-37/27
	España	2	3	España Alfonso XIII	1913 1915		15700t, 139.9x24.0x7.8m, 12b,4st, 15500hp, 19.5kts, 854p; 230belt, 90deck, 234turrets, 250CT; 4x2-305/50, 20x1-102/50, 4x1-47/50

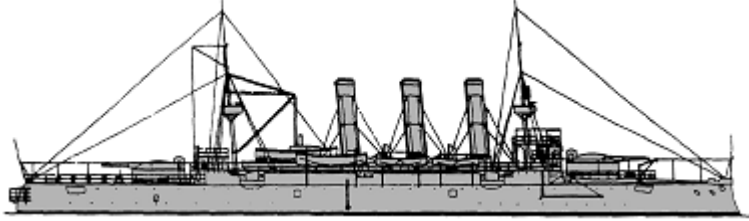
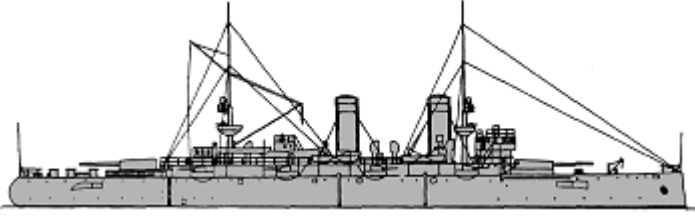

## CRUISERS

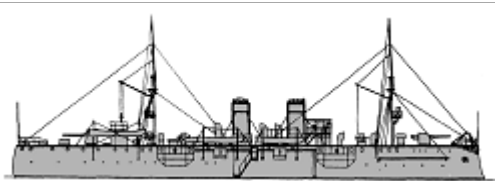
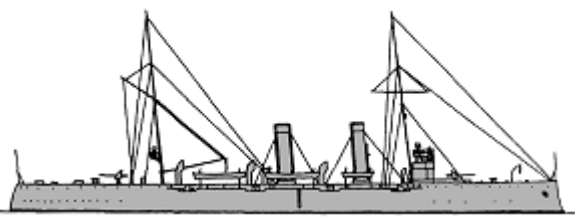
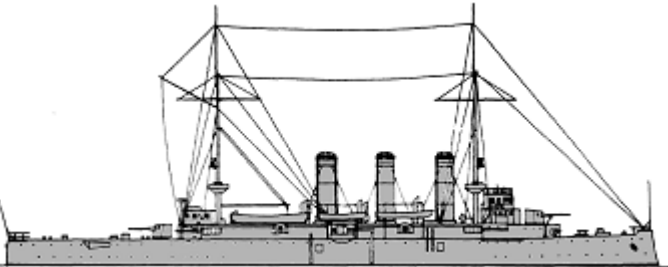
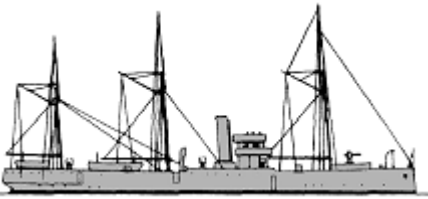

CA	Carlos V	1	1	Carlos V	1897		10100t, 115.8x20.4x7.6m, 12b,2vte, 18500hp, 20kts, 583p; 50belt, 50deck, 250barbettes, 300CT; 2x1-280/35, 8x1-140/36, 4x1-57/42, 2x1-42/43, 4x1-37/27, 6-356TT
	Princesa de Asturias	2		Princesa de Asturias	1903		7549t, 111.0x18.6x6.6m, 6b,2hte, 14800hp, 20kts, 542p; Harvey- 300belt, 57deck, 100turrets, 200CT; 2x1-240/41, 8x1-140/33, 8x1-57/42, 10x1-37/27, 5-450TT
		3		Cataluña	1904		
	Río de La			Río de La			1950t, 76.3x10.8x4.4m, 2vte, 7100hp, 20kts, 213p; steel- 20slopes, 15deck, 120CT; 2x1-140/43,



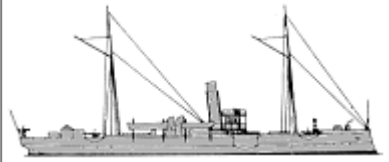
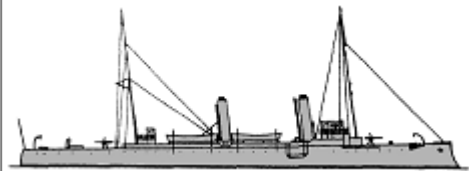

CL	Plata	1	1	Plata	1900		4x1-100/56, 6x1-57/42, 2x1-37/27, 2-356TT
	Extremadura	1	2	Extremadura	1902		2180t, 88.4x11.0x4.3m, 4b,2vte, 7000hp, 20kts, 246p; 50deck, 30CT; 8x1-101/50, 2x1-75/14, 4x1-57/42, 2x1-37/20
	Reina Regente	1	3	Reina Regente	1910		5871t, 110.9x16.1x5.0m, 12b,2vte, 11000hp, 19.5kts, 497p; 120slopes, 90deck, 75shields, 90CT; (2x2+6x1)-150/48, 12x1-57/42, 8x1-37/27
CLL	Velasco	1	1	Infanta Isabel	1888		1152t, 67.4x9.8x3.9m, 4b,1hc, 1500hp, 13kts, 173p; 1x1-66/40, 10x1-57/42

## TORPEDO SHIPS

PGT	Temerario	2	1	Temerario	1891		630t, 58.0ppx6.7x3.2m, 2b,2vte, 2600hp, 19kts, 91p; steel- 13deck; 2x1-120/35(1), 4x1-57/42, 1x4-25/42(1), 2x1-356TT(1)
			2	Marqués de Molins	1894		
	María de Molina	3	3	María de Molina	1898		830t, 71.6ppx8.0x2.7m, 4b,2vte, 3500hp, 19.5kts, 91p; 152CT; 8x1-57/42(3,4), 6x1-57/42(5), 2x1-42/42(5), (1+2x1)-356TT
4			Marqués de la Victoria	1900			
5			Álvaro de Bazán	1900			
DD	Furor	1	1	Terror	1896		450t, 67.1ppx6.7x1.7m, 4b,2vte, 6000hp, 28kts, 67p; 2x1-75/42, 2x1-57/42, 2x1-37/27, 2x1-356TT
	Audaz	3	2	Audaz	1898		430(2,3)-457(4)t, 69.8x6.9x1.8m, 4b,2vte, 7500hp, 30kts, 67p; 2x1-75/42, 2x1-57/42, 2x1-37/27, 2x1-356TT
			3	Osado	1898		
			4	Proserpina	1898		
	Bustamante	3	5	Bustamante	1914		530t, 67.4x6.7x1.7m, 3b,3st, 6250hp, 28kts, 70p; 5x1-57/50, 2x2-450TT
			6	Villaamil	1916		

							
		7	Cadarso	1917			
TB	T-1	18	1	T-1	1912		190t, 52.3x5.0x1.5m, 2b,3st(1-7)-2b,2st(8-18), 3750hp, 26kts, 31p; 3x1-47/50, (1x2+1x1)-450TT
			2	T-2	1912		
			3	T-3	1912		
			4	T-4	1913		
			5	T-5	1913		
			6	T-6	1914		
			7	T-7	1915		
			8	T-8	1915		
			9	T-9	1915		
			10	T-10	1915		
			11	T-11	1916		
			12	T-12	1916		
			13	T-13	1916		
			14	T-14	1916		
			15	T-15	1917		
			16	T-16	1917		
			17	T-17	1917		
			18	T-18	1918		

### SUBMARINES



SS	Isaac Peral	1	1	Isaac Peral	1917		488/750t, 60.1x5.8x3.4m, 2d/em, 1200/680hp, 15/10kts, 28p, 50m; 1x1-76/23, 4-450TT
	A1	3	2	A1 Narciso Monturiol	1917		262/319t, 45.6x4.2x3.1m, 2d/em, 700/500hp, 12.8/8kts, 17p, 45m; 2-450TT
			3	A2 Cosme Garcia	1917		
			4	A3	1917		

### ESCORTS

PC	Delfín	3	1	Delfín	1911	No picture	158t, 11kts; 1x1-57/42
			2	Dorado	1911		
			3	Gaviota	1911		

### OTHER FIGHTING SHIPS

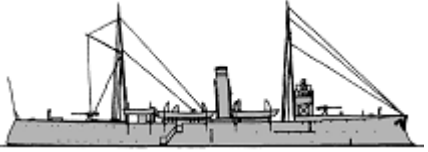
	Mac-Mahón	1	1	Mac-Mahón	1888	No picture	115t, 27.6x4.9x1.8m, 2b,2vte, 150hp, 9kts, 15p; 2x1-42/42, 1x5-37/17
	Hernan Cortés	2	2	Hernan Cortés	1895	No picture	295t, 47.4x6.6x1.9m, 1b,1vte, 352hp, 13kts, 53p; 2x1-75/42, 2x1-57/42
			3	Vasco Núñez de Balboa	1895		

PG	Recalde	4	4	Recalde	1911		811t, 65.5x9.1x3.0m, 2b,2vte, 1200hp, 13.5kts, 130p; 4x1-76/50
			5	Laya	1911		
			6	Bonifaz	1911		
			7	Lauria	1912		
PR	Perla	1	1	Perla	1889	No picture	42t, 19.0x3.6x1.8m, 110hp, 7kts, 26p; 1x2-25/42
	Cartagenera	1	2	Cartagenera	1908		27t, 16.3x3.6x1.2m, 1b,1vc, 120hp, 12kts; 1x1-42/42

## MINE WARFARE SHIPS

ML	Anteo	1	1	Anteo	1903	No picture	342t, 40.0x6.6x2.1m, 1b,1vte, 650hp, 11kts; 40mines, sweeps
----	-------	---	---	-------	------	------------	---



© Ivan Gogin, 2014

[home](#)[World navies yesterday](#)[1920](#)

# Sweden 01 January 1920

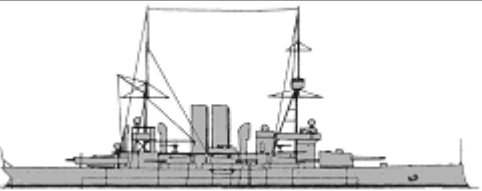
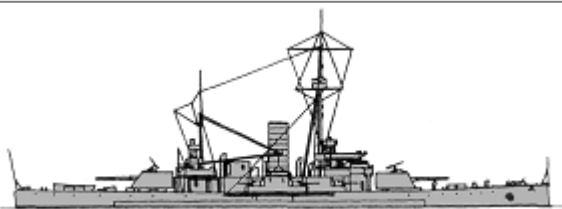
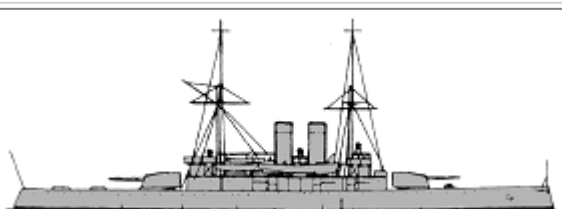
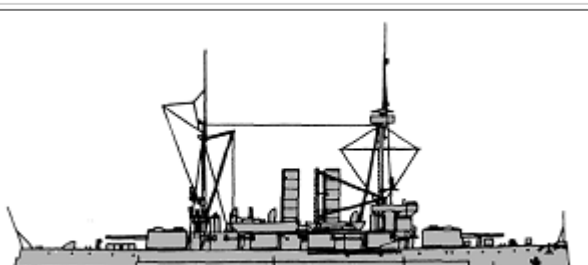
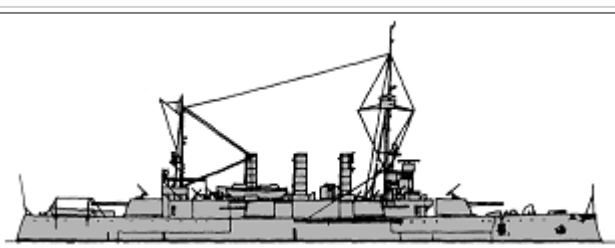
## BATTLESHIPS

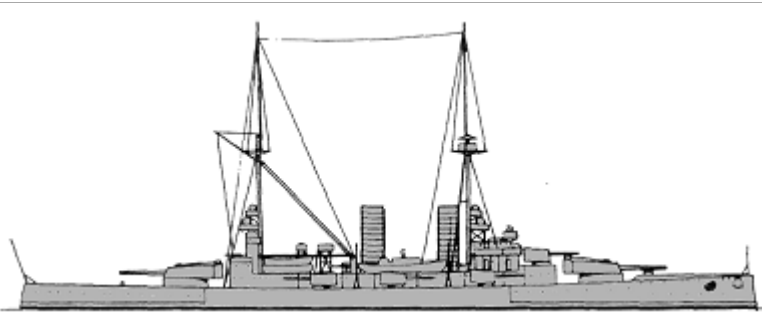



BC	Svea	1	Svea	1886		3273(1)-3300(2,3)t, 75.7(1)-78.8(2)-79.5(3)x14.8(1)-14.6(2,3)-5.1m, 6b,2vc, 3640(1)-4700(2,3)hp, 14.7(1)-16(2,3)kts, 252p; compound(1)-steel(2,3)- 297(1)-293(2,3)belt, 49deck, 190(KC)turret; 1x1-209/43, 7x1-152/43, 11x1-57/50	
		2	Göta	1891			
		3	Thule	1893			
	Oden	3	4	Oden	1897		3715(4)-3720(5,6)t, 86.3x14.8x5.3m, 6b,2vte, 5350hp, 16.5kts, 254p; steel(4)-Harvey(5,6)- 243(4)-240(5,6)belt, 49deck, 200(4)-190(5,6)turrets, 247(4)-190(5,6)CT; 2x1-254/41, 4x1-120/43(4), 6x1-120/43(5,6), 10x1-57/52
			5	Thor	1899		
			6	Njord	1899		
	Dristigheten	1	7	Dristigheten	1901		3600t, 89.0x14.8x4.9m, 8b,2vte, 5400hp, 16.5kts, 275p; Harvey- 200belt, 50deck, 200turrets, 247CT; 2x1-209/43, 6x1-152/43, 10x1-57/50, 2-450TT
	Äran	4	8	Äran	1902		3735t, 89.7x15.0x5.0m, 8b,2vte, 6500hp, 17kts, 275p; 175belt, 48deck, 190turrets, 200CT; 2x1-209/43, 6x1-152/43, 10x1-57/50, 2x1-37/34, 2-450TT
			9	Wasa	1902		
			10	Tapperheten	1903		
			11	Manligheten	1904		
	Oscar II	1	12	Oscar II	1907		4584t, 95.6x15.4x5.5m, 10b,2vte, 9400hp, 18kts, 331p; 150belt, 50deck, 190turrets, 157CT; 2x1-209/43, 4x2-152/49, 10x1-57/50, 3x1-37/34, 2-450TT

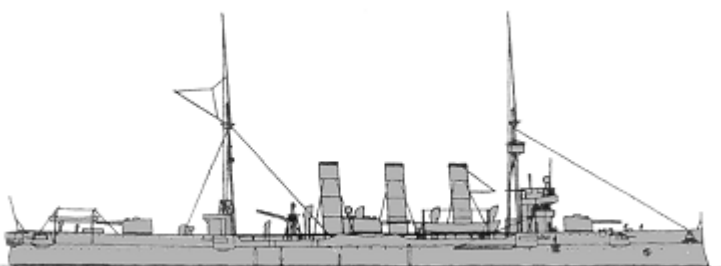
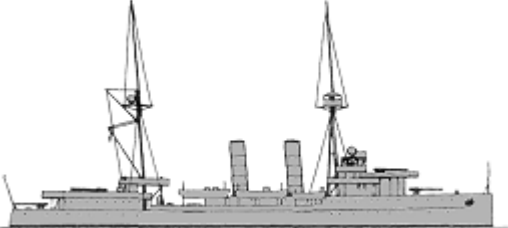

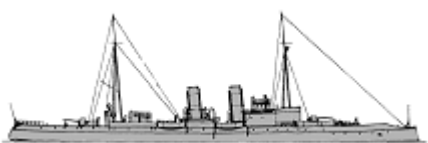

	Sverige	1	13	Sverige	1917		7516t, 120.0x18.6x6.3m, 12b,4st, 25400hp, 22.5kts, 427p; 200belt, 45deck, 200turrets, 175CT; 2x2-283/44, (1x2+6x1)-152/49, 6x1-75/49, 2x1-57/50, 2-533TT
MON	John Ericsson	2	2	Thordön Tirfing	1866 1867		1476t, 60.8x13.8x3.7m, 2b,1vde, 380hp, 7kts, 80p; iron- 118belt, 25deck, 261turret, 237CT; 1x2-120/43, 8x1-57/50(2), 8x1-47/49(1)

## CRUISERS



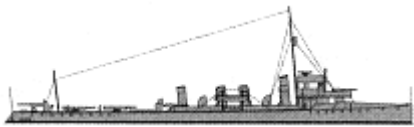
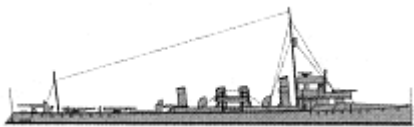



CA	Fylgia	1	1	Fylgia	1907		4734t, 115.1x14.8x6.3m, 12b,2vte, 12000hp, 21.5kts, 320p; 100belt, 35deck, 125turrets, 100CT; 4x2-152/49, 14x1-57/50, 2-450TT
CM	Clas Fleming	1	1	Clas Fleming	1914		1800t, 80.2x10.4x4.3m, 8b,2st, 6500hp, 20kts, 160p; 25deck, 75CT; 4x1-120/48, 100mines

## TORPEDO SHIPS

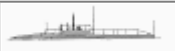







PGT	Örnen	4	1	Örnen	1897		844(1)-846(2)-835(3)-814(4)t, 67.7(1-3)-70.7(4)x8.2(1-3)-8.3(4,5)x3.1(1-3)-3.0(4)m, 8b,2vte, 4000hp, 20kts, 113p; 2x1-120/43, 4x1-57/50, 1-381TT
			2	Claes Horn	1898		
			3	Jacob Bagge	1898		
			4	Psilander	1900		
	Mode	1	1	Mode	1902		453t, 67.1x6.2x2.7m, 4b,2vte, 6000hp, 30kts, 62p; 6x1-57/50, 2x1-450TT
	Magne	1	2	Magne	1905		460t, 65.8x6.3x2.5m, 4b,2vte, 7200hp, 30kts, 67p; 6x1-57/50, 2x1-450TT
	Wale	1	3	Wale	1908		461t, 66.1x6.3x2.8m, 4b,2vte, 7665hp, 30kts, 54p; 2x1-75/49, 4x1-57/50, 2x2-450TT

DD	Ragnar	3	4	Ragnar	1909		460t, 66.1x6.3x2.7m, 4b,2vte, 7200hp, 30kts, 54p; 4x1-75/49, 2x2-450TT
			5	Sigurd	1909		
			6	Vidar	1910		
	Hugin	2	7	Hugin	1911		500t, 66.3x6.5x2.1m, 4b,2st, 10000hp, 33kts, 72p; 4x1-75/49, 2x2-450TT
			8	Munin	1913		
	Wrangel	2	9	Wrangel	1918		498t, 72.0x6.9x2.4m, 4b,2gt, 13000hp, 34kts, 81p; 4x1-75/49, (2x2+2x1)-450TT
10			Wachtmeister	1918			
TB 1cl	Komet	12	1	Komet	1896		120t, 39.8x4.8x2.5m, 1b,1vc, 1300hp, 23kts, 18p; 2x1-37/37, (1+1x1)-381TT
			2	Blixt	1898		
			3	Meteor	1899		
			4	Stjerna	1899		
			5	Orkan	1900		
			6	Bris	1900		
			7	Vind	1900		
			8	Virgo	1902		
			9	Mira	1902		
			10	Orion	1903		
			11	Sirius	1903		
			12	Kapella	1904		
	Plejad	17	13	Plejad	1905		106t, 40.2x4.4x2.6m, 2b,1vte, 2000hp, 26kts, 25p; 2x1-37/37, (1+1x1)-450TT
			14	Iris	1908		
			15	Thetis	1908		
			16	Spica	1908		
			17	Astrea	1908		
			18	Antares	1909		
			19	Arcturus	1909		
			20	Altair	1909		
			21	Argo	1909		
			22	Polaris	1909		
			23	Castor	1909		
			24	Pollux	1909		
			25	Perseus	1910		
			26	Regulus	1910		
			27	Rigel	1910		
			28	Vega	1910		
			29	Vesta	1910		



## SUBMARINES

SS	Hajen	1	1	N:r1	1905		111/127t, 21.6x3.6x3.0m, 1d/em, 135/70hp, 8/7kts, 11p, 30m; 1-450TT
	N:r2	3	2	N:r2	1909		138/230t, 26.8x3.6x3.0m, 1d/em, 420/200hp, 8.8/6.6kts, 12p, 30m; 1-450TT
			3	N:r3	1909		
			4	N:r4	1910		
	Svärdfisken	2	5	Svärdfisken	1915		252/370t, 45.5x4.2x3.0m, 2d/em, 1000/300hp, 14.2/8.5kts, 21p, 30m; 1x1-37/37, 2-450TT
			6	Tumlaren	1915		
	Delfinen	1	7	Delfinen	1915		260/370t, 42.5x4.3x3.0m, 2d/em, 1000/300hp, 13.6/9.4kts, 21p, 30m; 1x1-37/37, 2-450TT
	Laxen	2	8	Laxen	1915		140/170t, 26.8x3.6x2.0m, 2d/em, 700/200hp, 8.8/6.6kts, 10p, 30m; 1-450TT
			9	Gäddan	1915		
	Abborren	2	10	Abborren	1917		174/310t, 31.0x3.6x3.1m, 2d/em, 920/280hp, 9.5/7.4kts, 14p, 30m; 2-450TT
			11	Braxen	1917		

## ESCORTS

PC	Hugin	1	1	N:r15	1884		64t, 34.5x3.8x2.0m, 1b,1vc, 620hp, 18.5kts; 1x1-25/32
	Munin	3	2-4	N:r16-18	1887		66t, 34.8x3.8x2.0m, 1b,1vc, 620hp, 18.5kts; 1x1-25/57
	Gondul	2	5, 6	N:r21, 22	1894		86t, 38.6x4.3x2.1m, 1b,1vc, 850hp, 19.5kts, 18p; 2x1-25/57
	Blixt	2	7, 8	N:r7, 8	1883-1885		43t, 30.5xxm, 1b,1vc, 420hp, 19kts; 1x1-25/32, sweeps
	Narf	2	9, 10	N:r9, 10	1886		45t, 30.5x3.6x1.9m, 1b,1vc, 440hp, 19.5kts; 1x1-25/32, sweeps
	Bygve	2	11, 12	N:r11, 12	1887		57t, 31.5x3.6x1.9m, 1b,1vc, 460hp, 18.5kts; 1x1-25/58, sweeps
	Agne	2	13, 14	N:r13, 14	1891-1892		55t, 30.6x3.6x1.9m, 1b,1vc, 460hp, 18.9kts; 1x1-25/58, sweeps
	N:o79	2	15, 16	N:r25, 26	1903		55t, 31.7x3.6x1.9m, 1b,1vc, 700hp, 20.5kts; 1x1-37/37, sweeps
	N:o83	2	17, 18	N:r23, 24	1903		56t, 32.4x3.6x1.9m, 1b,1vc, 635hp, 20.8kts; 1x1-37/37, sweeps

## OTHER FIGHTING SHIPS

MONL	Gerda	1	1	Gerda	1872		459t, 39.7x8.0x2.5m, 2b,2hc, 133hp, 7.6kts, 42p; iron- 76belt, 418turret, 254CT; 1x1-120/44, 2x1-25/32
	Ulf	1	2	Björn	1874		460t, 39.8x8.0x2.5m, 2b,2hc, 155hp, 8kts, 42p; iron- 76belt, 418turret, 254CT; 1x1-120/44, 2x1-57/50
PG	Urd	1	1	Skagul	1878	No picture	550t, 53.6x8.1x2.8m, 2b,2hc, 780hp, 72p; 51CT; 1x1-152/30, 1x1-120/43, 2x1-57/50
	Svenskund	1	2	Svenskund	1891	No picture	280t, 38.5x7.9x3.0m, 440hp, 12.5kts; 2x1-57/50, mines

## MINE WARFARE SHIPS

	Ångkranpramen N:r3	1	1	Ångkranpramen N:r3	1879	No picture	190t, 6.5kts; mines
			2	Ångkranpramen N:r5	1904		

ML	Ångkranspramen N:r3	4	3	Ångkranspramen N:r6	1904	No picture	120t, 7.5kts; mines
			4	Ångkranspramen N:r7	1904		
			5	Ångkranspramen N:r7	1905		
	Ångkranspramen N:r9	1	6	Ångkranspramen N:r9	1912	No picture	120t, 9.1kts; mines
	Edda	1	7	Edda	1885	No picture	640t, 55.8x8.3x3.1m, 2b,2vc, 960hp, 13.5kts, 76p; 4x1-57/50, mines
Disa	1	8	Disa	1877	No picture	550t, 51.1x8.1x3.0m, 2b,2hc, 590hp, 11.5kts, 71p; 51CT; 2x1-57/50, mines	
Urd	1	9	Rota	1878	No picture	550t, 53.6x8.1x2.8m, 2b,2hc, 780hp, 72p; 51CT; 1x1-152/30, 1x1-57/18, mines	
MS	Sökaren	3	1	Sökaren	1918	No picture	266t, 27.8x6.8x3.0m, 1b,1vte, 465hp, 10kts, 17p; 1x1-57/18, mines, sweeps
			2	Sveparen	1918		
			3	Sprängaren	1918		



© Ivan Gogin, 2014



[home](#)[World navies yesterday](#)[1920](#)

# Turkey 01 January 1920



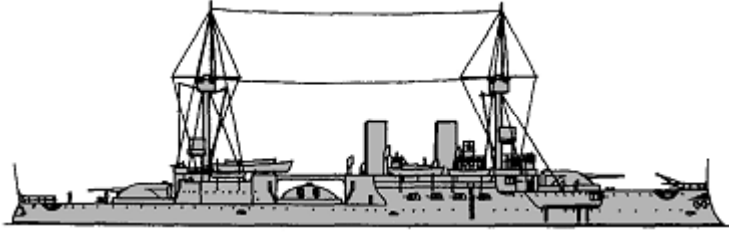
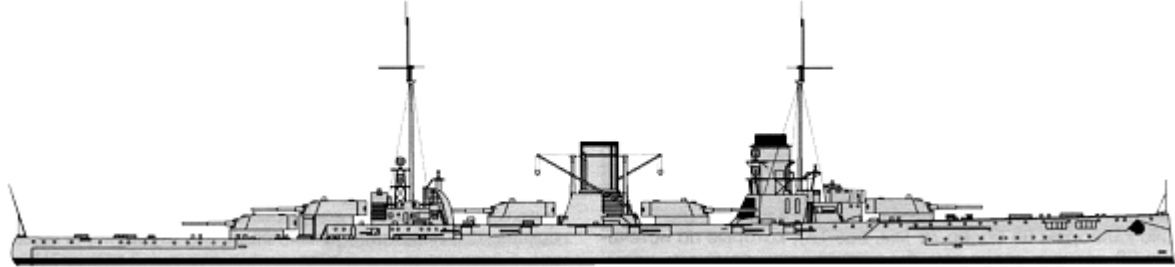

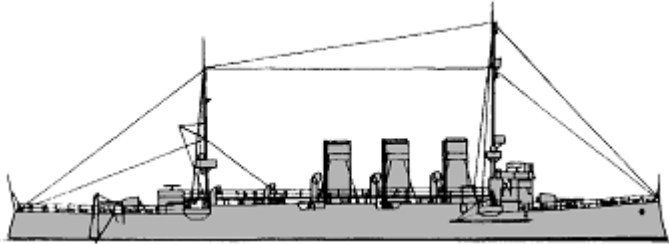
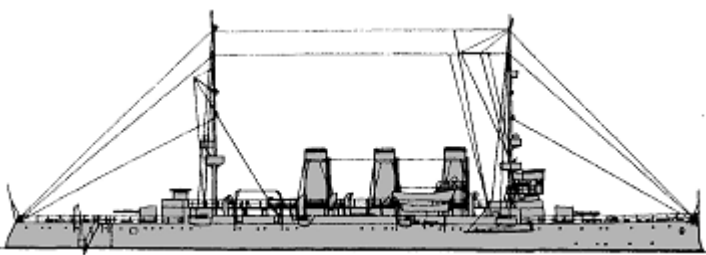

## BATTLESHIPS

BB	Torgud Reis	1	1	Torgud Reis	1894		10670t, 115.7x19.5x7.6m, 12b,2vte, 10200hp, 16.5kts, 600p; Harvey- 400belt, 60deck, 300barbettes, 300CT; 2x2-283/37, 1x2-283/32, 6x1-105/32, 6x1-88/27, 3-450TT
CB	Yavuz Sultan Selim	1	1	Yavuz Sultan Selim	1912		25400t, 186.6x29.5x8.7m, 24b,4st, 52000hp, 25.5kts, 1053p; 270belt, 75decks, 230turrets, 350CT; 5x2-283/47, 10x1-149/42, 8x1-88/45, 8x1-88/42, 4-500TT

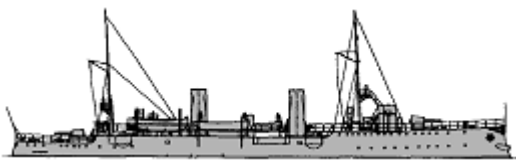
## CRUISERS

CL	Mecidiye	1	1	Mecidiye	1903		3967t, 102.4x12.8x4.8m, 16b,2vte, 12500hp, 22kts, 312p; 102slopes, 38deck; 10x1-130/53
	Hamidiye	1	2	Hamidiye	1904		3904t, 112.0x14.5x4.9m, 6b,2vte, 12000hp, 22kts, 302p; 102slopes, 38deck; 2x1-152/45, 6x1-120/45, 2x1-47/50, 2x1-37/30, 2x1-450TT

## TORPEDO SHIPS

PGT	Peyk-i Şevket	2	1	Peyk-i Şevket	1907		775t, 80.1ppx8.4x4.6m, 4b,2vte, 5100hp, 21kts, 105p; 2x1-105/37, 6x1-57/42, 2x1-37/42, (1+2x1)-450TT
			2	Berk-i Satvet	1907		
DD	Samsun	3	1	Samsun	1907		284t, 58.2x6.3x2.8m, 2b,2vte, 5950hp, 28kts, 23p; 1x1-65/50, 6x1-47/50, 2x1-450TT
			2	Taşoz	1907		
			3	Basra	1907		
TB	Berk Efşan	1	1	Berk Efşan	1894	No picture	230t, 59.9x6.6x2.4m, 2b,2vte, 3500hp, 21kts, 50p; 6x5-37/27, 2-428TT
	Hamidiye	1	2	Yunus	1902		145t, 50.6x5.6x1.2m, 3b,2vte, 2400hp, 26kts, 30p; 1x1-47/42
	Akhisar	1	3	Akhisar	1904		165t, 51.0x5.7x1.4m, 2b,2vte, 2400hp, 24kts, 30p; 1x1-47/42, 2x1-37/20, 1x1-450TT
	Antalya	2	4	Draç	1907		165t, 51.0x5.7x1.4m, 2b,2vte, 2700hp, 26kts, 30p; 1x1-47/42(5), 2x1-37/20, 2x1-450TT(5)
			5	Musul	1907		
	Demirhisar	2	6	Sultanhisar	1907		101t, 40.2x4.4x1.9m, 2b,1vte, 2200hp, 26kts, 23p; 2x1-37/20, (1+1x2)-450TT
7			Sivrihisar	1907			

## OTHER FIGHTING SHIPS

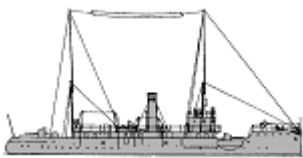
PG	Aydin Reis	4	1	Aydin Reis	1914		503t, 54.5x8.2x2.4m, 3b,2vte, 1025hp, 14kts, 75p; 2x1-75/37(1,2)
			2	Preveze	1914		
			3	Sakiz	1914		
			4	Bürak Reis	1914		
	İsa Reis	2	5	İsa Reis	1914		413t, 47.0x7.9x1.3m, 3b,2vte, 850hp, 14kts, 60p; 3x1-75/48, 2x1-47/50
			6	Kemal Reis	1914		
ADV	-	1	1	Galata	1896		120t
AGS	-	2	1	İskenderun	1895		142t
			2	Rüsumet No4	1891		310t

## COASTAL FORCES

YP	No1	10	1-10	No11, 13-15, 17, 18, 20-23	1911-1914		20t, 18.3ppx3.3x1.6m, 1pe, 70hp, 11.9kts, 6p; 2x1-37/27
----	-----	----	------	----------------------------	-----------	---	---

## MINE WARFARE SHIPS

ML	Nusret	1	1	Nusret	1913		365t, 40.2ppx7.6x3.4m, 2b,2vte, 1200hp, 15kts; 2x1-47/42, 40mines
AML	-	1	1	Selanik			270t; 25mines

© Ivan Gogin, 2015



[home](#)[World navies yesterday](#)[1920](#)

# United Kingdom 01 January 1920

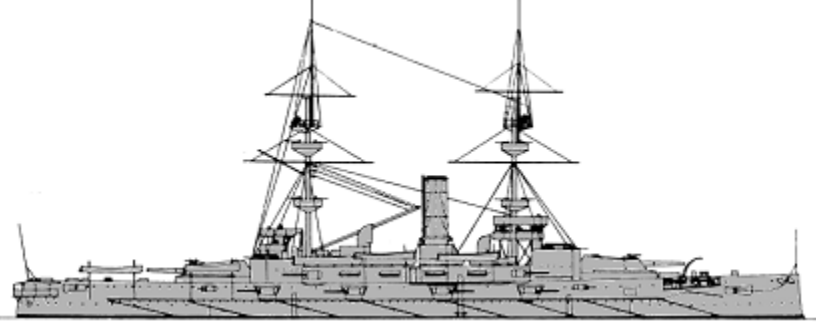
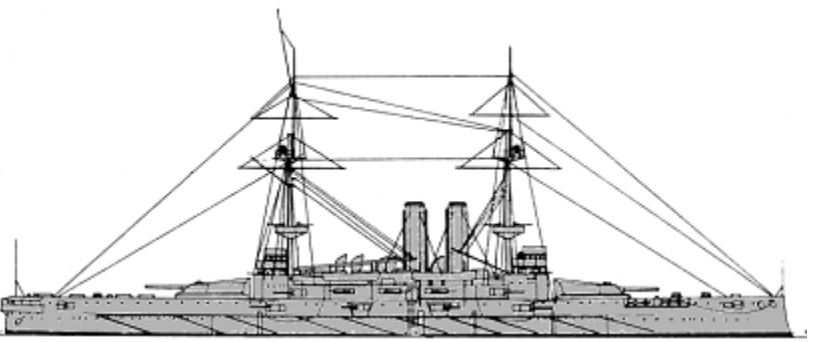
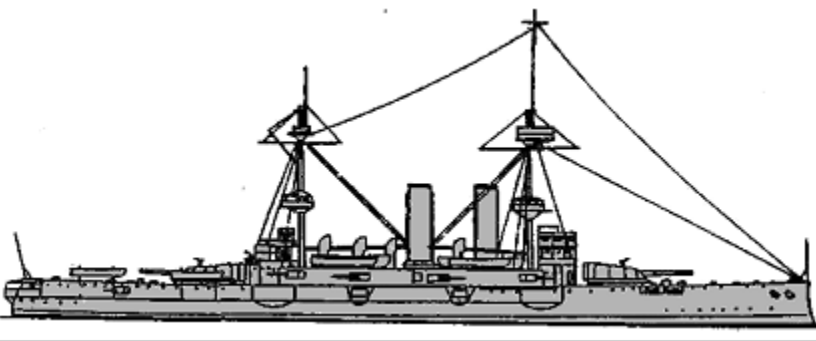
## BATTLESHIPS

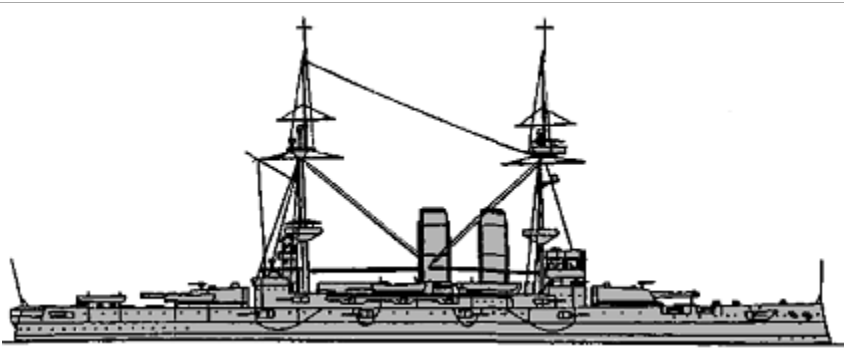
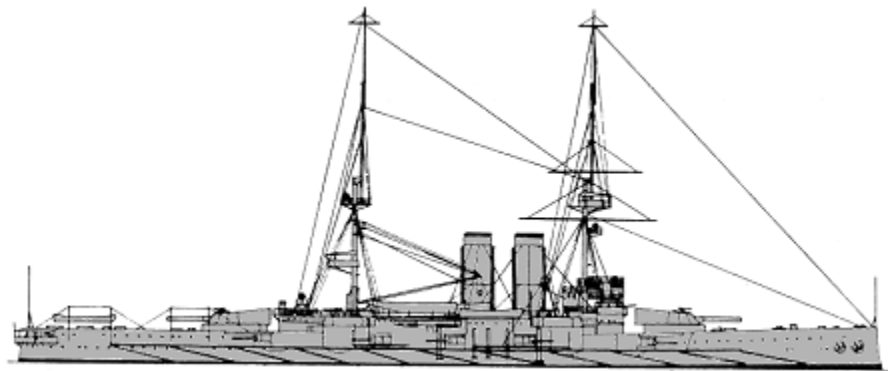
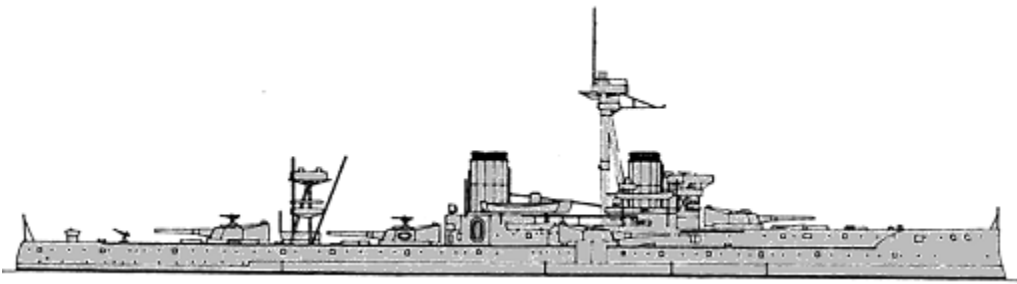
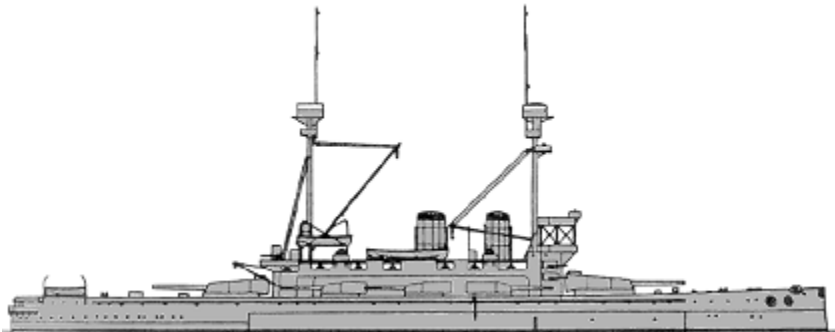
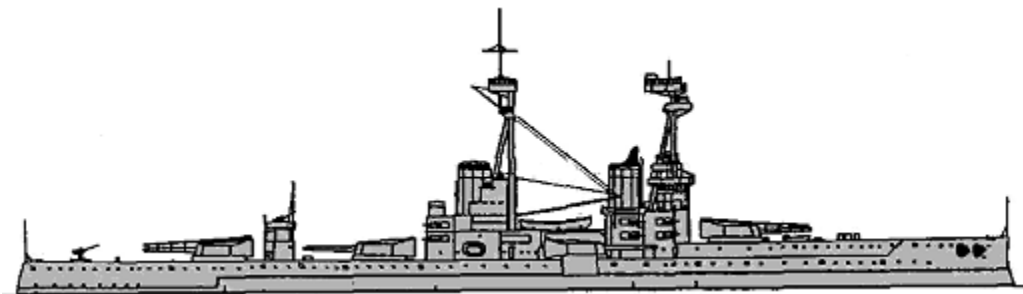
Majestic	1	1	Caesar	1898		16060T, 128.3X22.9X8.2m, 8b,2vte, 12000hp, 17kts, 672p; Harvey: 229belt, 102deck, 254gunhouses, 356CT; 2x2-305/35, 12x1-152/40, 16x1-76/40, 12x1-47/40, 5-450TT
Canopus	1	2	Glory	1900		14300t, 128.5x22.6x8.0m, 20b,2vte, 13500hp, 18kts, 682p; Harvey: 152(Krupp)belt, 76deck, 203gunhouses, 305CT; 2x2-305/35, 12x1-152/40, 10x1-76/40, 6x1-47/40, 4-450TT
Formidable	1	3	Implacable	1901		15800t, 131.6x22.9x7.9m, 20b,2vte, 15000hp, 18kts, 780p; 229belt, 76decks, 254turrets, 356CT; 2x2-305/40, 10x1-152/45, 16x1-76/40, 6x1-47/40, 4-450TT
Duncan	2	5	Duncan Exmouth	1903 1903		14900-15200t, 131.7x23.0x7.9m, 24b,2vte, 18000hp, 19kts, 720p; 178belt, 51decks, 254turrets, 305CT; 2x2-305/40, 12x1-152/45, 10x1-76/40, 6x1-47/40, 4-450TT

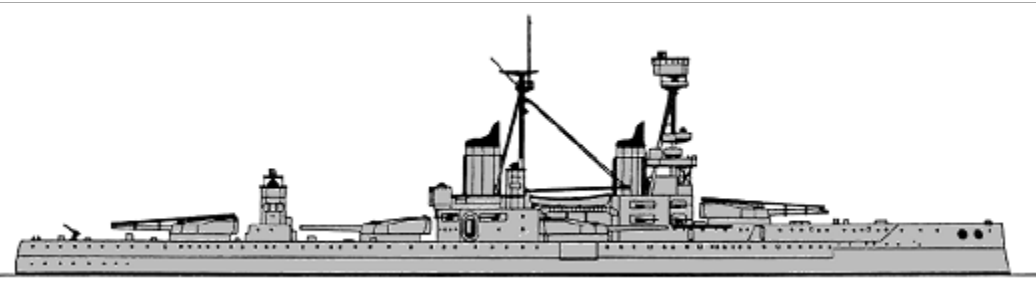
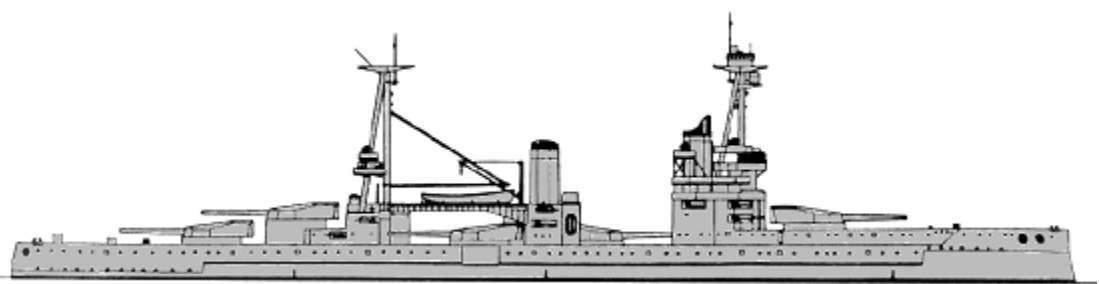
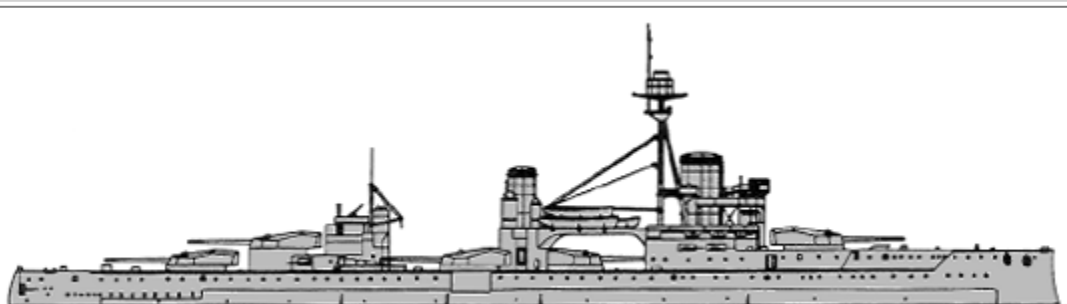
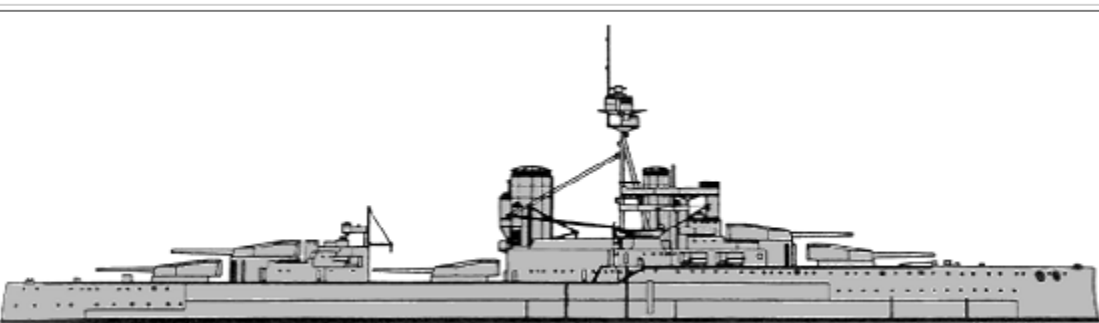
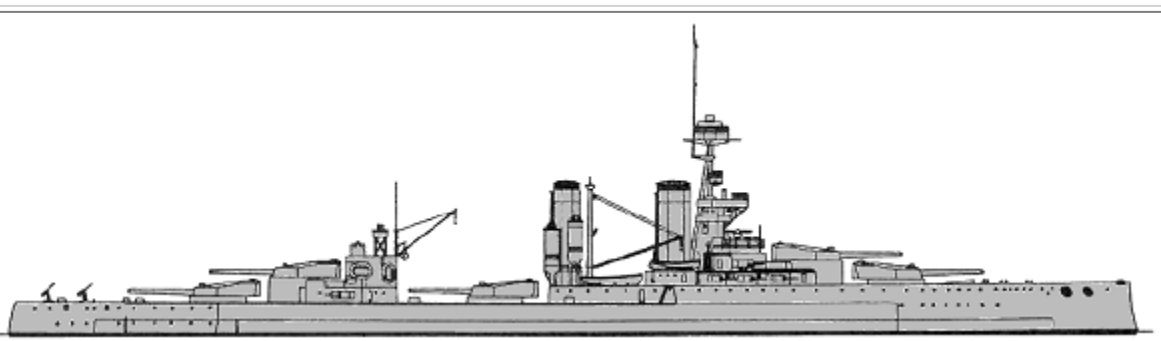

						
King Edward VII	6	Commonwealth	1905		17009-17290t, 138.3x23.8x7.7m, 16b,1vte(6)-15b,2vte(7), 18000hp, 18.5kts, 777p; 229belt, 64decks, 305turrets, 305CT; 2x2-305/40, 4x1-234/47, 4x1-152/45(6), 10x1-152/50(7), 14x1-76/45, 14x1-47/40(6), 14x1-47/50(7), 4-450TT	
	7	Hindustan	1905			
Dreadnought	1	8	Dreadnought	1906		21845t, 160.6x25.0x9.4m, 18b,4st, 23000hp, 21kts, 773p; 279belt, 76decks, 279turrets, 279CT; 5x2-305/45, 24x-76/50, 5-450TT
Agamemnon	9	Agamemnon	1908		17820(9)-17683(10)t, 135.2x24.2x7.9m, 15b,2vte, 16750hp, 18kts, 800p; 305belt, 102deck, 305turrets, 305CT; 2x2-305/45, (4x2+2x1)-234/50, 24x1-76/50, 2x1-47/40, 5-450TT	
	2	10	Lord Nelson			1908
Bellerophon	11	Bellerophon (TS)	1909		22102t, 160.3x25.2x8.3m, 18b,4st, 23000hp, 20.7kts, 733p; 254belt, 102decks, 279turrets, 279CT; 5x2-305/45, 18x1-102/50(11,12), 16x1-102/50(13), 1x1-76/45(13), 4x1-47/40, 2-450TT, 2aircraft(1 Pup, 1 1 1/2-strutter)	
	12	Temeraire (TS)	1909			
	3	13	Superb (TS)			1909
	14	St. Vincent	1909			

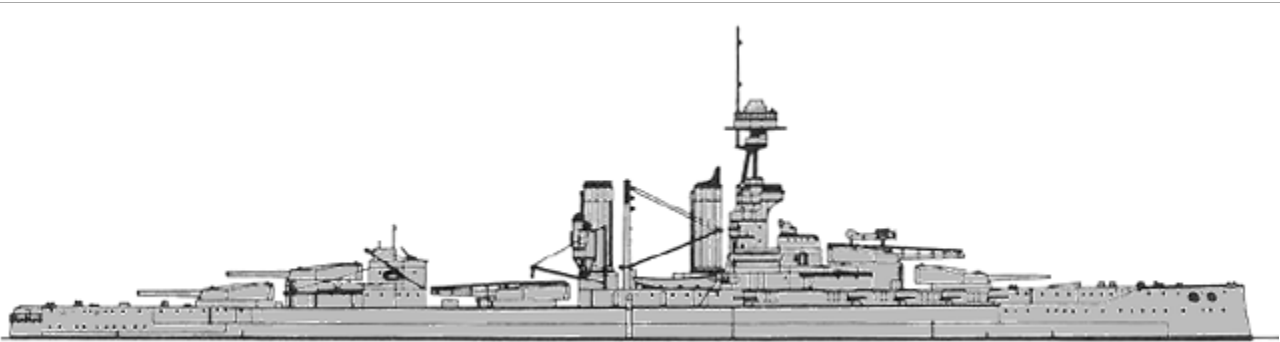
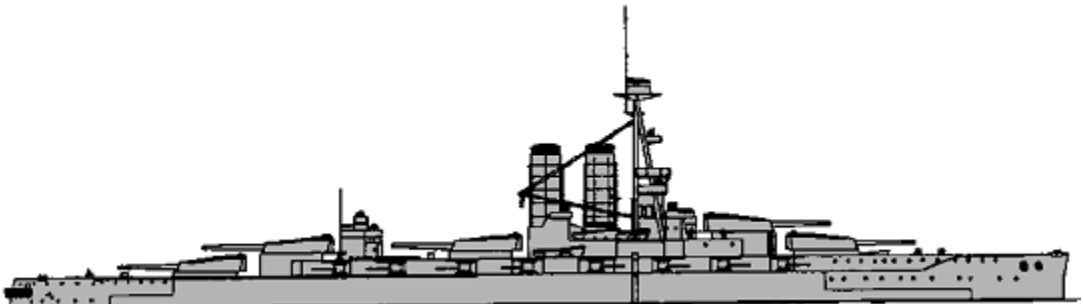
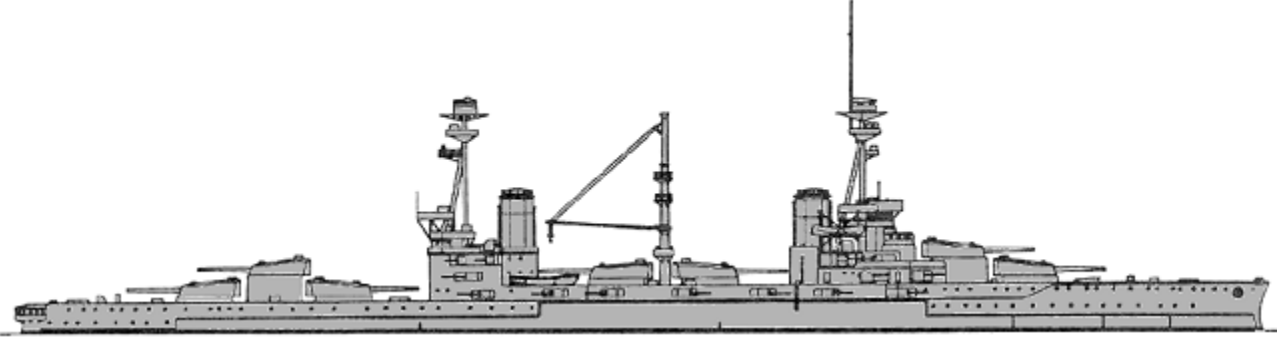
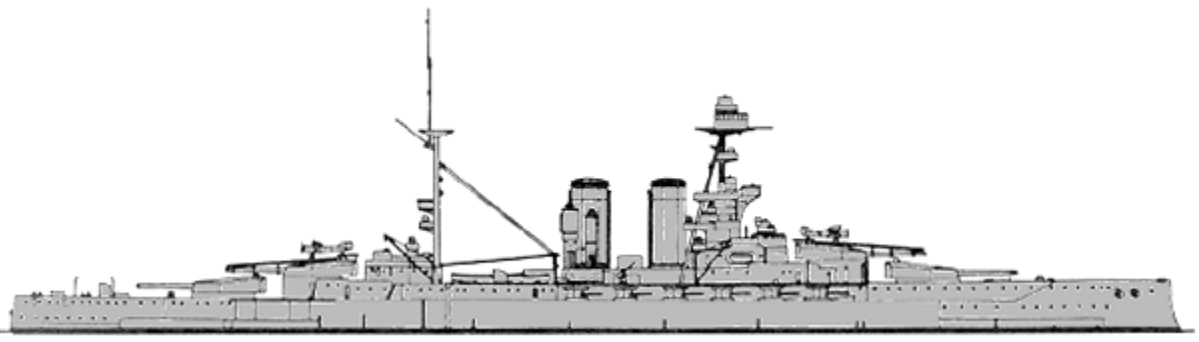
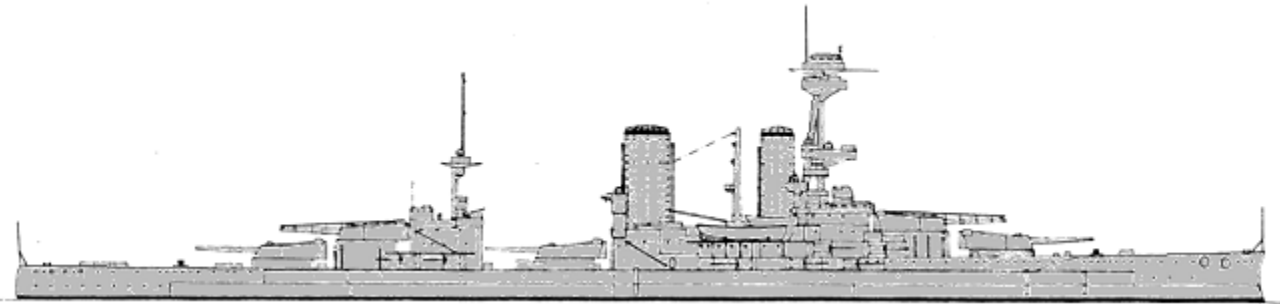

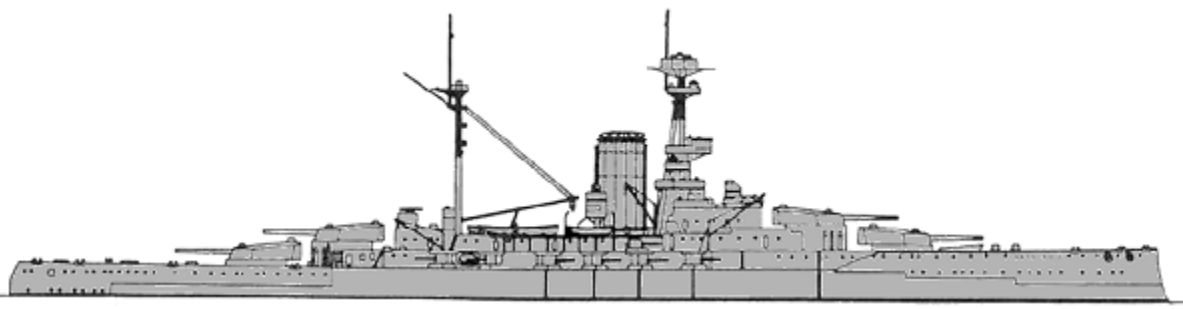
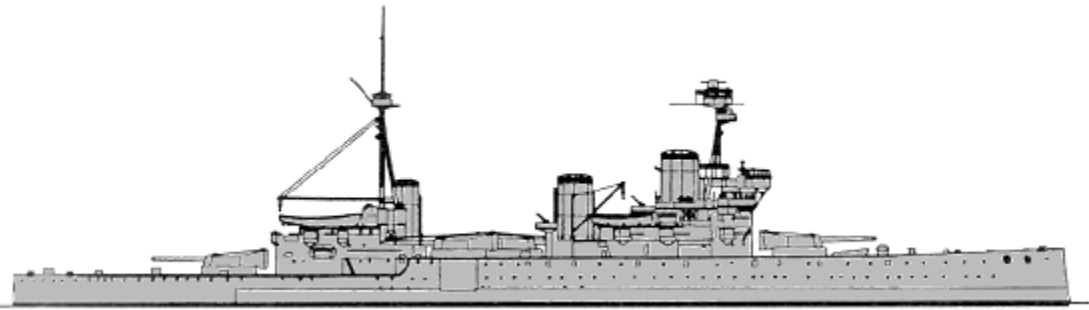
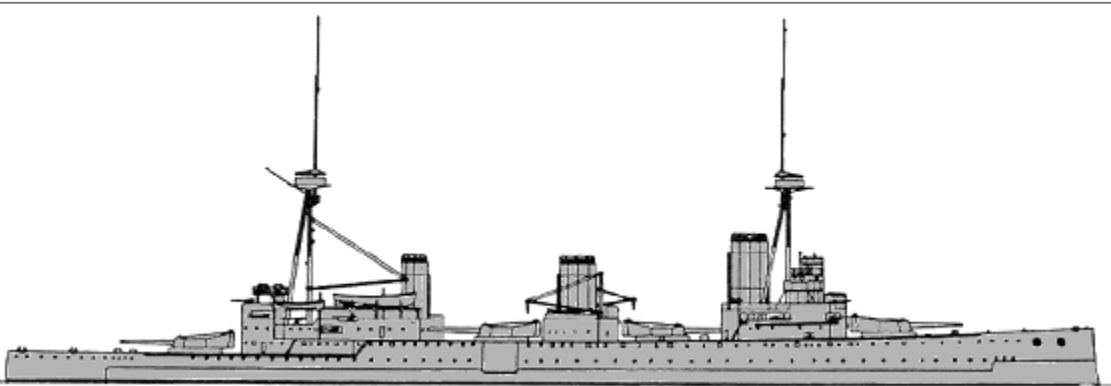
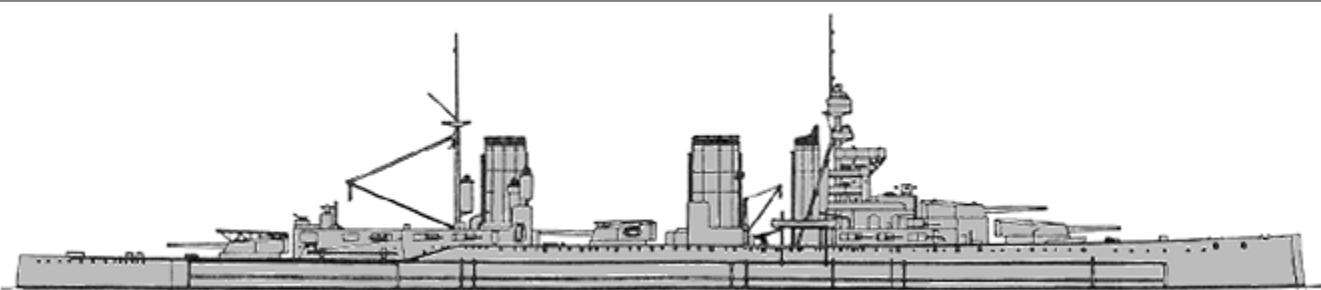
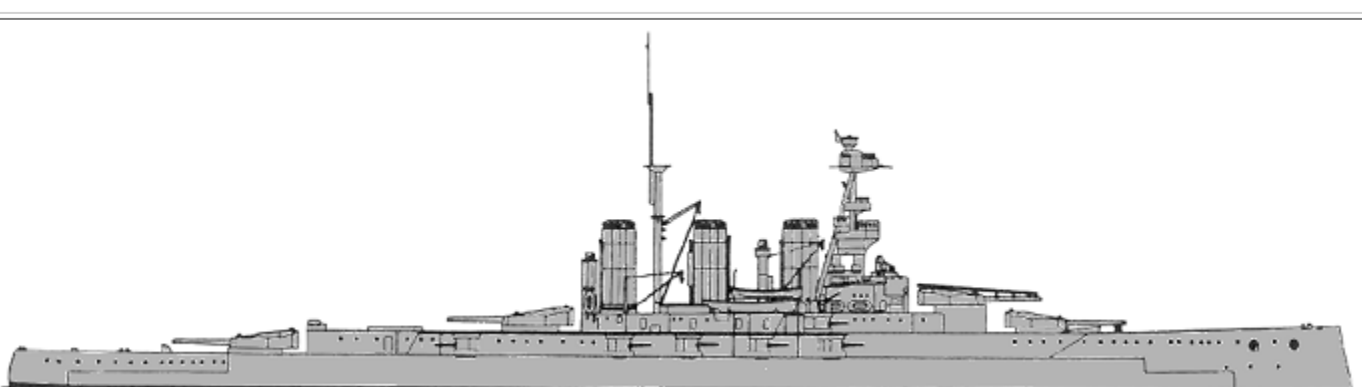
BB	St. Vincent	2	(TS)			23030t, 163.4x25.6x8.5m, 18b,4st, 24500hp, 21kts, 718p; 254belt, 76deck, 279turrets, 279CT; 5x2-305/50, 19x1-102/50, 1x1-76/45, 4x1-47/40, 2-450TT, 2aircraft(1 Pup, 1 1 <sup>1</sup> / <sub>2</sub> -strutter)(15)	
		15	Collingwood (TS)	1910			
	Neptune	1	16	Neptune	1911		22720t, 166.4x25.9x8.7m, 18b,4st, 25000hp, 21kts, 759p; 254belt, 76deck, 280turrets, 280CT; 5x2-305/50, 16x1-102/50, 2x1-76/45, 4x1-47/40, 2-450TT
	Colossus		17	Colossus	1911		23086t, 166.4x25.9x8.8m, 18b,4st, 25000hp, 21kts, 755p; 279belt, 102deck, 279turrets, 279CT; 5x2-305/50, 14x1-102/50, 1x1-76/45, 4x1-47/40, 3-533TT
			18	Hercules	1911		
	Orion		19	Orion	1912		25870t, 177.1x27.0x7.6m, 18b,4st, 27000hp, 21kts, 752p; 305belt, 102deck, 279turrets, 254CT; 5x2-343/45, 16x1-102/50(19-21), 17x1-102/50(22), 1x1-76/45, 4x1-47/40, 3-533TT, 2aircraft(1 Pup, 1 1 <sup>1</sup> / <sub>2</sub> -strutter)
			20	Thunderer	1912		
		21	Monarch	1912			
		22	Conqueror	1912			
King George V		23	King George V	1912		25700t, 182.1x27.1x8.7m, 18b, 4st, 31000hp, 21kts, 782p; 305belt, 102deck, 279turrets, 279CT; 5x2-343/45, 14x1-102/50, 4x1-47/40, 3-533TT, 2aircraft(1 Pup, 1 1 <sup>1</sup> / <sub>2</sub> -strutter)	
		24	Centurion	1913			
		25	Ajax	1913			
		26	Iron Duke	1914		30380t, 189.8x27.4x9.0m, 18b,4st, 29000hp, 21.2kts, 1022p; 305belt,	
		27	Marlborough	1914			
		28	Benbow	1914			

Iron Duke	4					<p>89deck, 279turrets, 305CT; 5x2-343/45, 12x1-152/45, 2x1-76/45, 4x1-47/40, 4-533TT, 2aircraft(1 Pup, 1 1<sup>1</sup>/<sub>2</sub>-strutter)</p>
		29	Emperor of India	1914		
Erin	1	30	Erin	1914		<p>25250t, 170.5x27.9x8.7m, 15b,4st, 26500hp, 21kts, 1070p; 305belt, 76deck, 279turrets, 305CT; 5x2-343/45, 16x1-152/50, 2x1-76/45, 6x1-57/50, 4-533TT, 2aircraft(1 Pup, 1 1<sup>1</sup>/<sub>2</sub>-strutter)</p>
Agincourt	1	31	Agincourt	1914		<p>30250t, 204.7x27.1x8.2m, 22b,4gt, 34000hp, 22kts, 1115p; 229belt, 64deck, 305turrets, 305CT; 7x2-305/45, 20x1-152/50, 10x1-76/50, 2x1-76/45, 3-533TT</p>
Queen Elizabeth	5	32	Queen Elizabeth	1915		<p>31500t, 196.8x27.6x8.8m, 24b,4st, 56000hp, 23kts, 951p; 330belt, 102decks, 330turrets, 280CT; 4x2-381, 12x1-152/45, 4x1-76/45, 4x1-47/40, 4-533TT, 2aircraft(1 Pup, 1 1<sup>1</sup>/<sub>2</sub>-strutter)</p>
		33	Warspite	1915		
		34	Barham	1915		
		35	Valiant	1916		
		36	Malaya	1916		
Canada	1	37	Canada	1915		<p>32300t, 201.5x28.0x8.7m, 21b,4st, 37000hp, 22.7kts, 1167p; 229belt, 64deck, 254turrets, 279CT; 5x2-356/45, 12x1-152/50, 2x1-76/45, 4x1-47/40, 4-533TT, 2aircraft(1 Pup, 1 1<sup>1</sup>/<sub>2</sub>-strutter)</p>

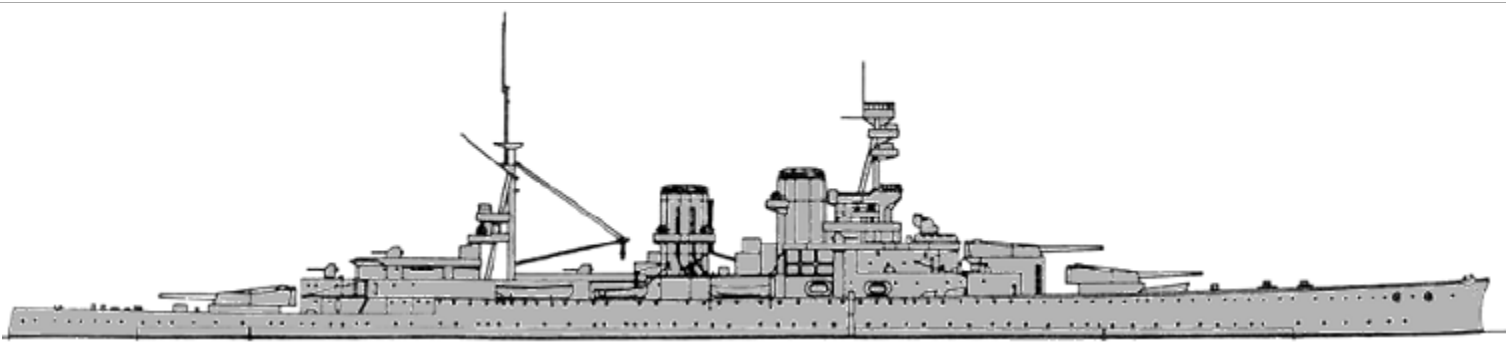
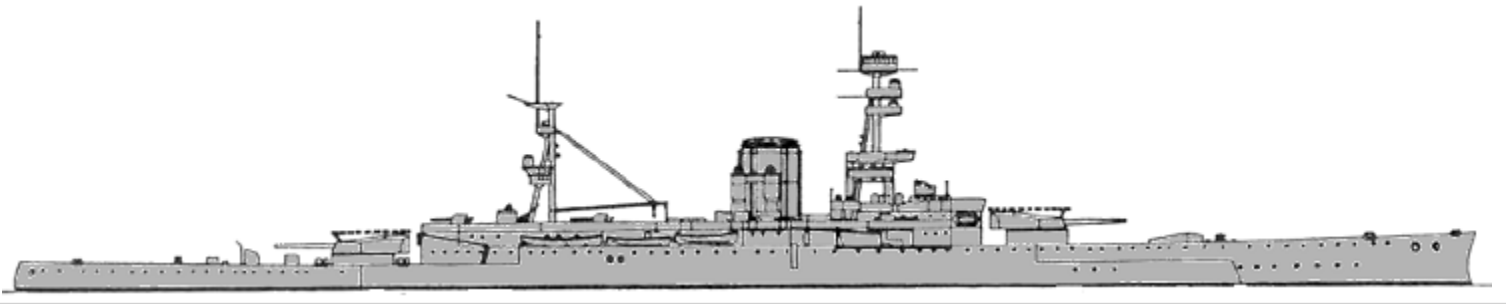
	Revenge	5	38	Royal Oak	1916		<p>31000(38,40)-32526(39,41)-33500(42)t, 190.3x27.0(38,40)-30.9(39,41)-31.3(42)x8.7(38,40)-8.3(39,41)-8.4(42)m, 18b,4gt, 40000hp, 22(38-41)-21.5(42)kts, 908-997p; 330belt, 89decks, 330turrets, 279CT; 4x2-381/42, 14x1-152/45, 2x1-76/45, 4x1-47/40, 4- 533TT, 2aircraft(1 Pup, 1 1<sup>1</sup>/<sub>2</sub>-strutter)</p>
			39	Resolution	1916		
			40	Royal Sovereign	1916		
			41	Revenge	1916		
			42	Ramillies	1917		
CB	Invincible	3	1	Indomitable	1908		<p>20078t, 172.8x22.1x8.0m, 31b,st, 41000hp, 25.5kts, 784p; 152belt, 89deck, 178turrets, 254CT; 4x2-305/45, 14x1-102/50(1), 12x1- 102/44(2), 1x1-76/45(1), 2x1-76/45(2), 4-450TT, 2aircraft(1 Pup, 1 1<sup>1</sup>/<sub>2</sub>- strutter)</p>
			2	Inflexible	1908		
	Indefatigable	1	3	New Zealand	1912		<p>22110t, 179.8x24.4x8.1m, 32b,4st, 44000hp, 25kts, 800p; 152belt, 89deck, 178turrets, 254CT; 4x2-305/45, 6x1-102/50, 4x1-47/40, 2x1- 40/39, 2-450TT, 2aircraft(1 Pup, 1 1<sup>1</sup>/<sub>2</sub>-strutter)</p>
	Lion	2	4	Lion	1912		<p>30945t, 213.4x27.0x8.4m, 42b,4st, 70000hp, 27kts, 997p; 229belt, 89deck, 229turrets, 254CT; 4x2-343/45, 15x1-102/50, 3x1-76/45(4), 2x1-76/45(5), 4x1-47/40, 2x1-40/39(5), 2-533TT, 2aircraft(1 Pup, 1 1<sup>1</sup>/<sub>2</sub>- strutter)</p>
			5	Princess Royal	1912		
	Tiger	1	6	Tiger	1914		<p>35710t, 214.6x27.6x8.7m, 39b,4st, 85000hp, 28kts, 1121p; 229belt, 76deck, 229turrets, 254CT; 4x2-343/45, 12x1-152/45, 2x1-76/45, 4x1- 47/40, 4-533TT</p>

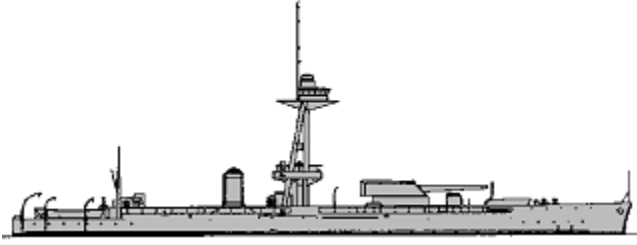
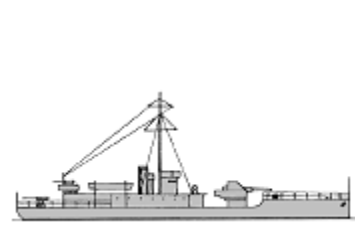
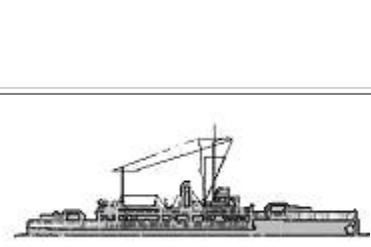

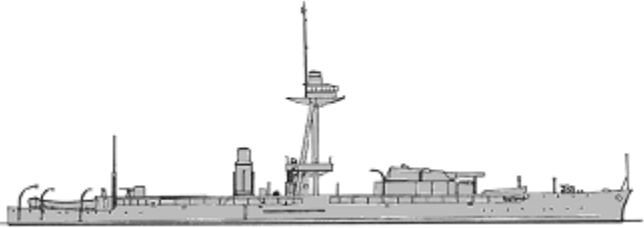
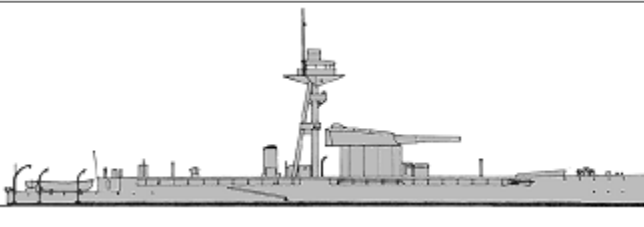
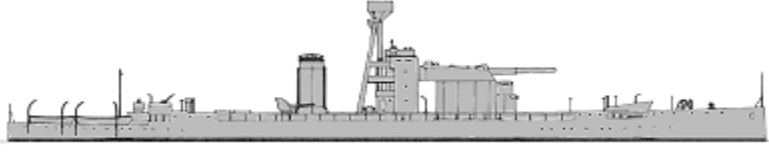
	Renown	7	Repulse	1916		30835t, 242.0x27.4x7.8m, 42b,4st, 112000hp, 30kts, 967p; 152belt, 107decks, 229turrets, 254CT; 3x2-381/42, (5x3+2x1)-102/44, 2x1-76/45, 4x1-47/40, 2-533TT, 2aircraft(1 Pup, 1 1 <sup>1</sup> / <sub>2</sub> -strutter)
		8	Renown	1916		
CBL	Courageous	1	Courageous	1917		22690t, 239.7x24.7x7.1m, 18b,4gt, 90000hp, 32kts, 828p; 76belt, 63deck, 229turrets, 254CT; 2x2-381/42, 6x3-102/44, 2x1-76/45, 2x1-47/40, (2x2+2)-533TT(1), (6x2+2)-533TT(2), 222mines(1), 2aircraft(1 Pup, 1 1 <sup>1</sup> / <sub>2</sub> -strutter)
		2	Glorious	1917		
MON	Humber	1	Humber	1913		1520t, 81.3x14.9x1.7m, 2b,2vte, 1450hp, 9.5kts, 140p; 76belt, 25deck, 102turret; 1x2-152/50(1), 1x1-152/45(1), 2x1-152/45(2,3), 2x1-120/18, 1x1-76/45(1), 4x1-47/50(1), 5x1-47/50(2,3)
		2	Severn	1914		
		3	Mersey	1914		
	Abercrombie	4	Abercrombie	1915		6150t, 102.0x27.4x3.1m, 2b,2vqe(4,6)-2b,2vte(5), 2000(4,6)-1800(5)hp, 6kts, 198p; 102belt, 51deck, 254turret; 1x2-356/45, 1x1-152/40(5), 2x1-76/50, 1x1-76/45(4), 2x1-76/45(5,6), 1x1-47/50(4,5), 1x1-40/39(4), 2x1-40/39(5)
		5	Roberts	1915		
		6	Havelock	1915		
	M15	7	M16	1915		650t, 54.0x9.4x2.1m, 2b,2vte(7,8)-4bsd(9-12,14)-4cpe(13), 800hp(7,8)-640(9-13)-480hp(14)hp, 11(7,8)-9(9-14)kts, 69p; 152turret; 1x1-234/47(7-9), 1x1-234/32(10,11), 1x1-190/50(12-14), 1x1-76/50(8,12), 1x1-76/45(7,9-12), 2x1-76/45(13,14), 1x1-57/40(8-11), 2x1-47/50(12), 2x1-40/39(13,14)
		8	M17			
		9	M18			
		10	M19			
		11	M20			
		12	M23			
		13	M24			
	M29	15	M29	1915		580t, 54.0x9.4x1.8m, 2b,2vte, 400hp, 9kts, 72p; 152shields; 2x1-152/45, 1x1-76/45(16,18), 1x1-57/40(15,17)
		16	M31	1915		
17		M32	1915			
18		M33	1915			
	General	19	Prince Rupert	1915		6150t, 102.3x26.6x2.9m, 2b,2vte, 1600(19)-2500(20,25)-2310(21-
		20	Sir John Moore	1915		
		21	Lord Clive	1915		
			General			

Lord Clive	8	22	Craufurd	1915		24,26)hp, 6.5kts, 194p; 152belt, 51deck, 267turret; 1x1-457/40(21,25), 1x2-305/35, 4x1-152/45(22), 2x1-152/45(19,23,25), 1x1-152/45(26), 4x1-102/44(20,21), 2x1-76/50(19,21,22), 4x1-76/50(20,24,26), 2x1-76/45(19,20,22-25), 1x1-76/45(26), 1x1-47/50(26), 1x1-40/39(19,24), 3x1-40/39(21), 2x1-40/39(20,22,23,25)
		23	Prince Eugene	1915		
		24	Earl of Peterborough	1915		
		25	General Wolfe	1915		
		26	Sir Thomas Picton	1915		
Marshal Soult	1	27	Marshal Soult	1915		6900t, 108.4x27.5x3.2m, 2d, 1500hp, 6kts, 187p; 102belt, 102deck, 330turret, 152CT; 1x2-381/42, 8x1-102/44, 2x1-76/50, 1x1-76/45, 1x1-47/50, 2x1-40/39
Erebus	2	28	Terror	1916		8450t, 123.4x26.9x3.6m, 4b,2vte, 6000hp, 12kts, 204p; 102belt, 102deck, 330turret; 1x2-381/42, 8x1-102/44, 2x1-76/50, 2x1-40/39
		29	Erebus	1916		
Gorgon	1	30	Gorgon	1918		5746t, 94.5x22.4x5.0m, 4b,2vte, 4000hp, 12kts, 305p; 178belt, 63decks, 203turrets, 203CT; 2x1-234/51, 4x1-152/49, 2x1-76/45, 4x1-40/39

## AIRCRAFT CARRYING SHIPS

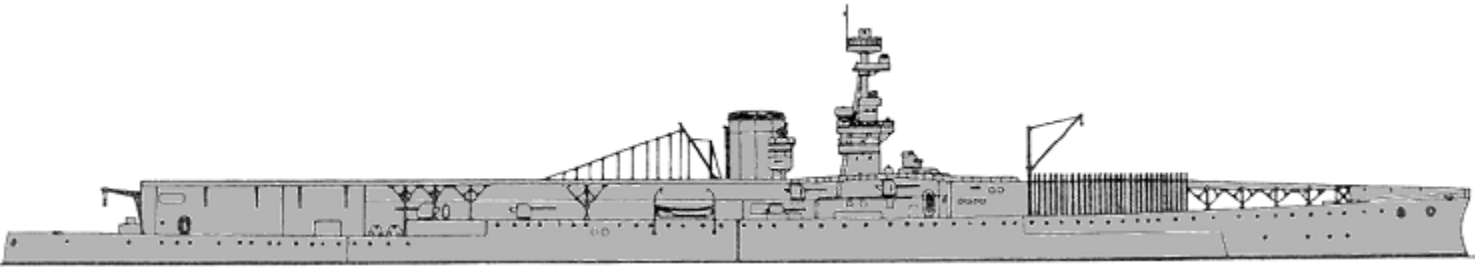
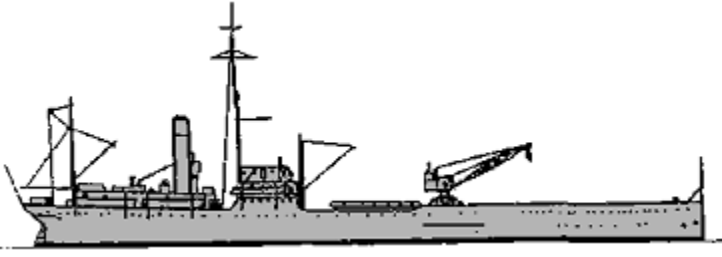
CV	Furious	1	1	Furious	1917		22890t, 239.7x26.8x6.4m, 18b,4gt, 90000hp, 31.5kts, 737p; 76belt, 76deck; 10x1-140/50, 6x1-76/45, (4x3+2)-533TT, 26aircraft(12 Camel, 2 1 <sup>1</sup> / <sub>2</sub> -strutter, 4 Short 184)
	Ark Royal	1	1	Ark Royal	1914		7400t, 111.6x15.5x5.5m, 2b,1vte, 3000hp, 11kts, 180p; 4x1-76/40, 7ac(2 Sopwith 807, 2 Wright Pusher, 1 Short 135, 2 Sopwith Tabloid)
							15750t, 172.5x20.7x6.4m, 12b,4gt, 20000hp, 20kts, 401p; 51magazines; 6x1-

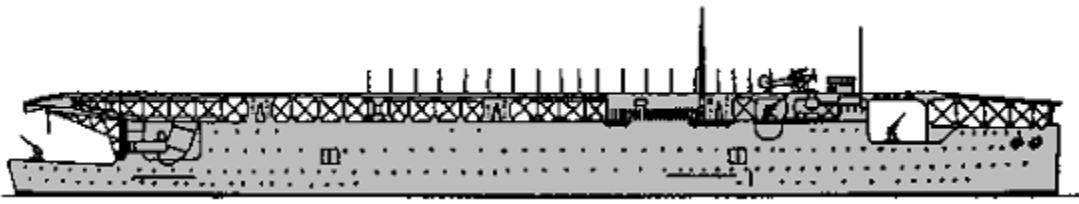
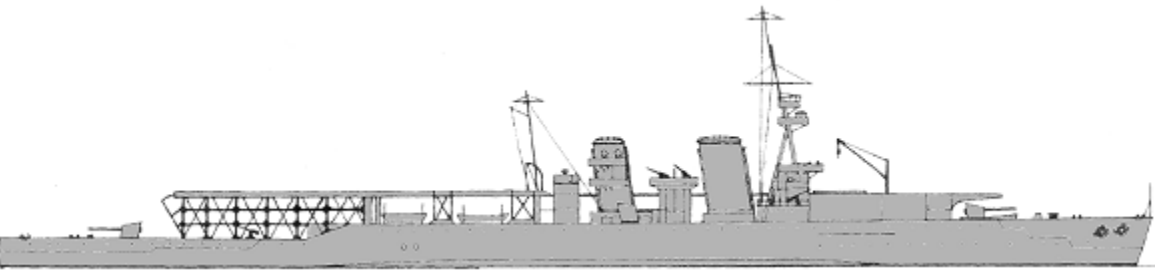
CVL	Argus	1	2	Argus	1918		102/45, 20aircraft (8 1 <sup>1</sup> / <sub>2</sub> -strutter, 2 Walrus, 2 Fairey III)
	Vindictive	1	3	Vindictive	1918		12400t, 184.4x19.8x5.9m, 12b,4gt, 60000hp, 30kts, 560p; 76belt, 38deck, 76CT; 4x1-190/45, 4x1-76/50, 4x1-76/45, 6-533TT, 12aircraft(3 Camel, 3 1 <sup>1</sup> / <sub>2</sub> -strutter, 3 Griffin, 3 Short 184)
AV	-	2	1	Vindex	1905		2950t, 110.2x12.8x4.2m, 3st, 11000hp, 23kts; 4x1-76/50, 1x1-57/40, 7seaplanes (Camel, Short 184, Campania)
			2	Manxman	1904		2048t, 104.0x13.0x4.9m, 3st, 6300hp, 21kts; 2x1-102/40, 1x1-57/40, 8seaplanes (Camel, Short 184, Campania)
	Pegasus	1	3	Pegasus	1917		3300t, 101.2x13.1x4.6m, 6b,2gt, 9500hp, 20kts, 280p; 4x1-76/40, 9aircraft (4 Camel, 1 Short 184, 3 Campania)
	Nairana	1	4	Nairana	1917		3070t, 107.3x13.9x4.3m, 6b,2gt, 6300hp, 20kts, 278p; 4x1-76/40, 7aircraft (2 Camel, 5 Campania)

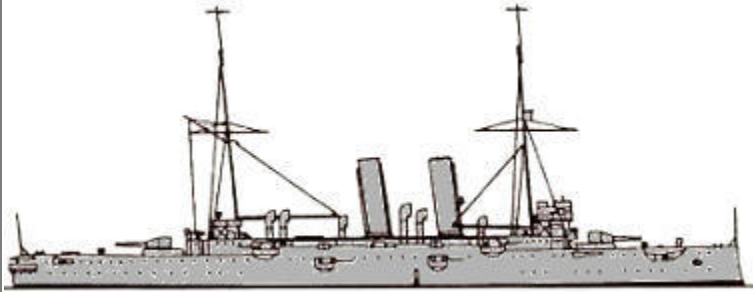
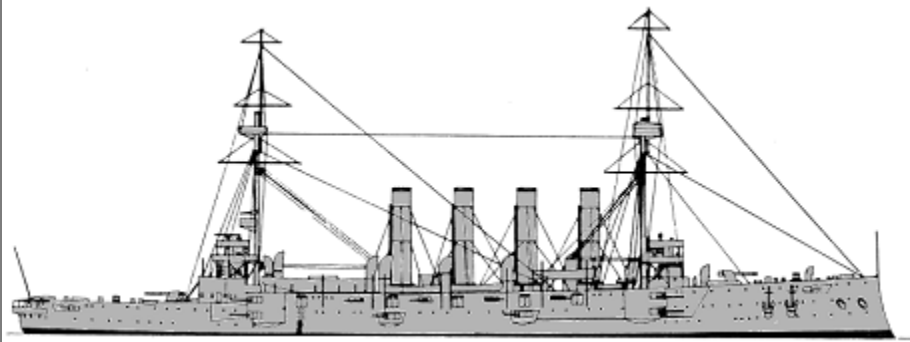

## CRUISERS

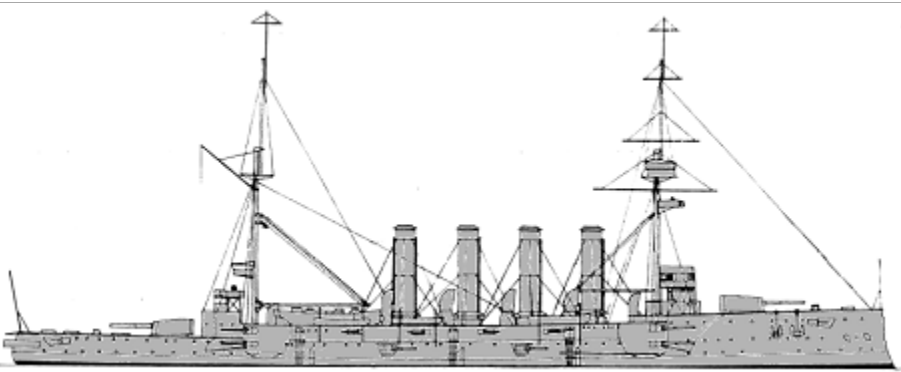
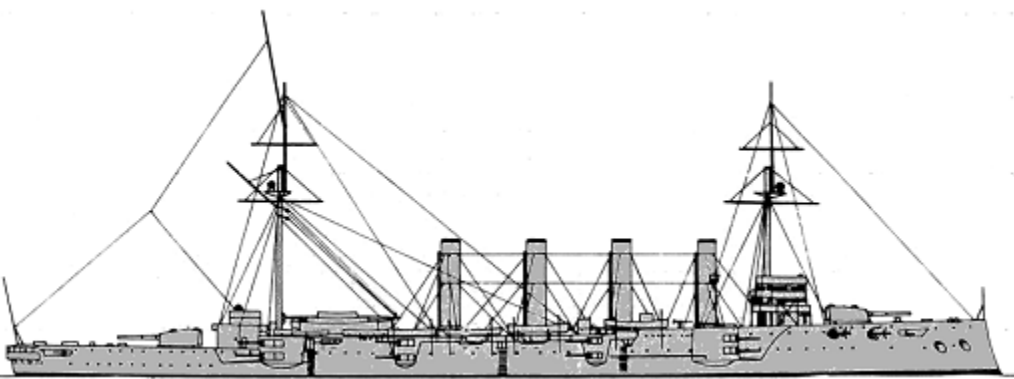
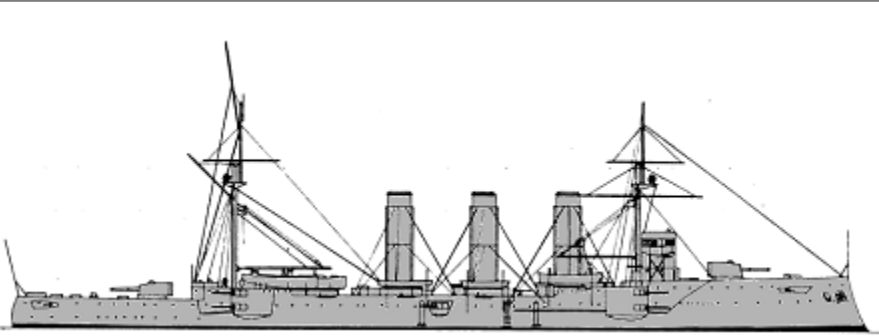
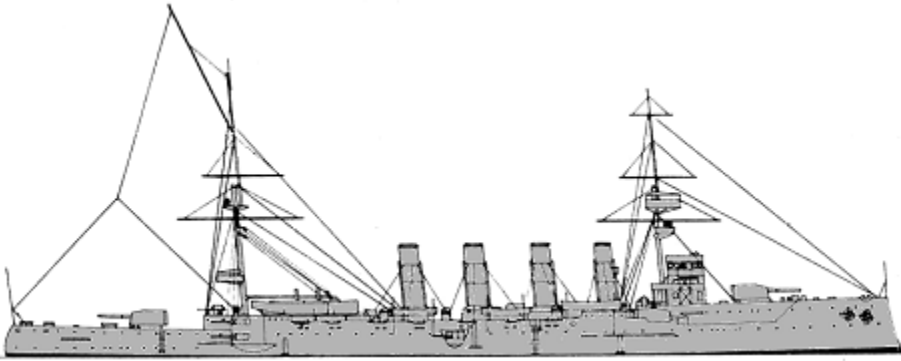

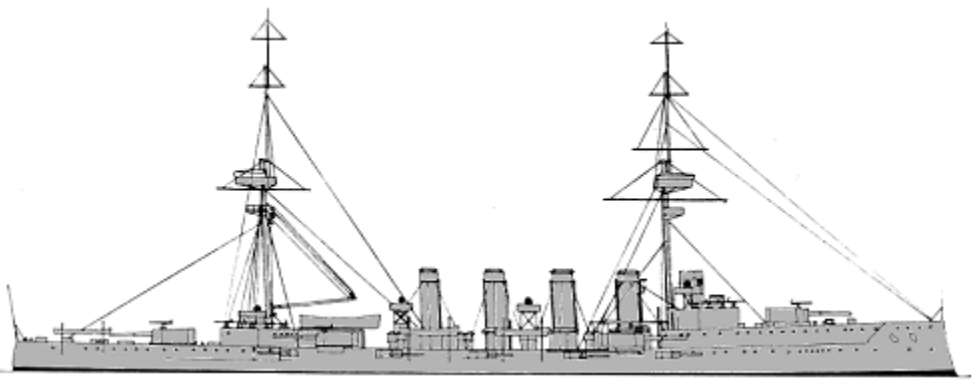
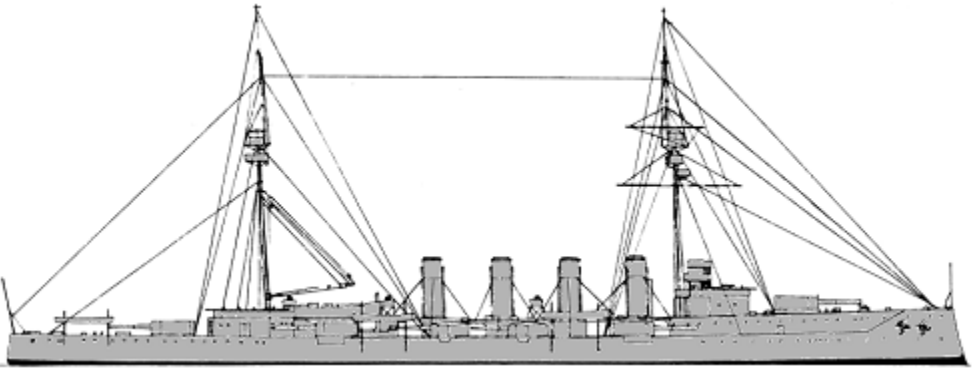
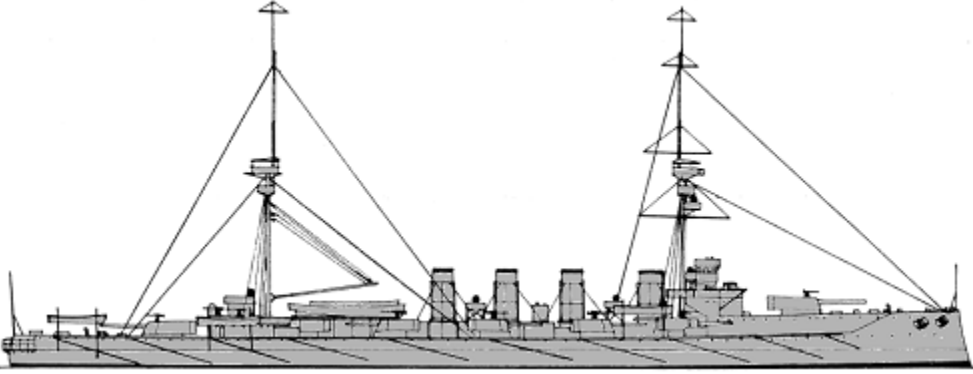
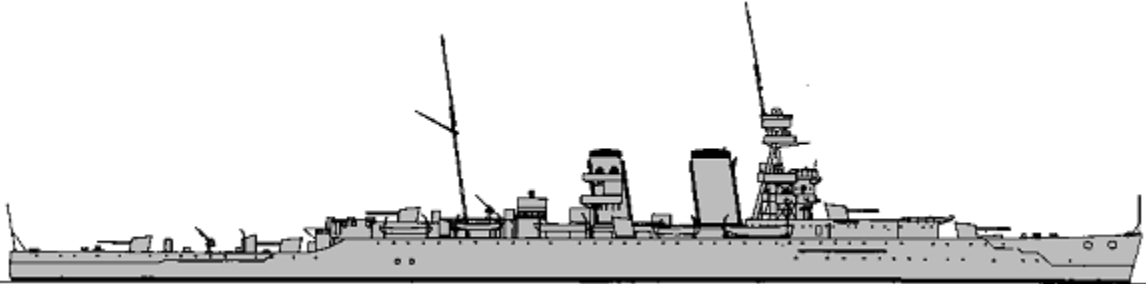
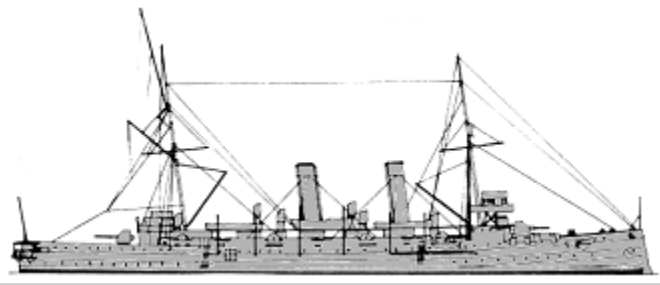
Edgar	4	1	Edgar	1893		7350t, 118.1x18.3x7.2m, 5b,2vite, 12000hp, 20kts, 544p; steel: 127deck, 152casemates, 305CT; 2x1-234/32, 10x1-152/40, 12x1-57/40, 5x1-47/40, 4-450TT
		2	Endymion	1894		
		3	Grafton	1894		
		4	Theseus	1896		
Diadem	1	5	Europa	1899		11000t, 141.0x21.0x7.8m, 30b,2vte, 16500(9,10)-18000(11-13)hp, 20.2(9-10)-20.7(11-13)kts, 677p; Harvey: 102deck, 114casemates, 305CT; 16x1-152/40, 14x1-76/40, 3x1-47/40, 3-450TT
		6	Bacchante	1902		12000t, 143.9x21.2x7.9m, 30b,2vte, 21000hp, 21kts, 760p; 152belt, 76deck, 152turrets, 305CT; 2x1-

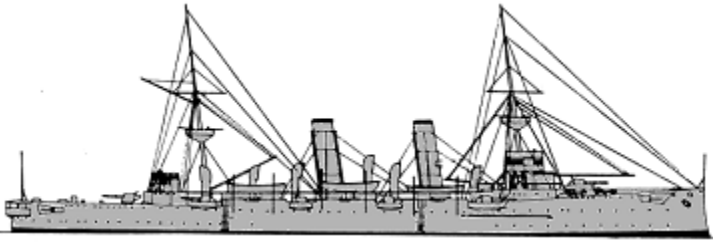
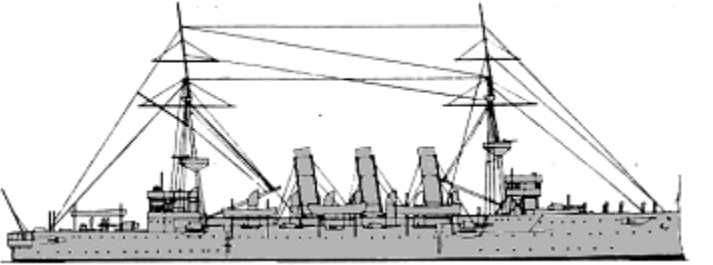
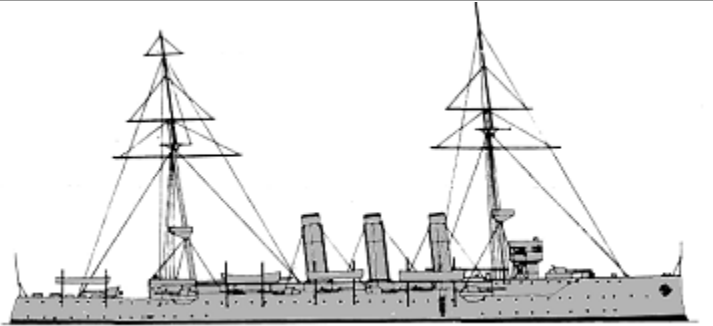
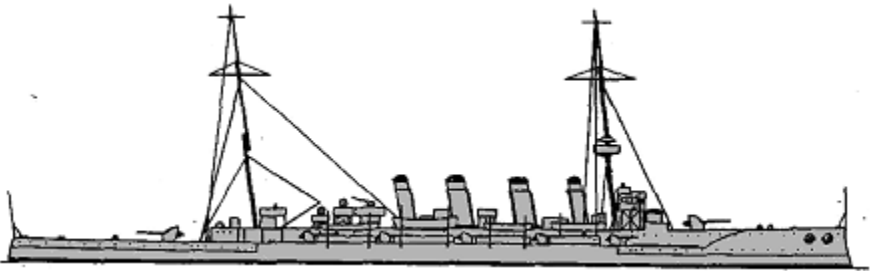
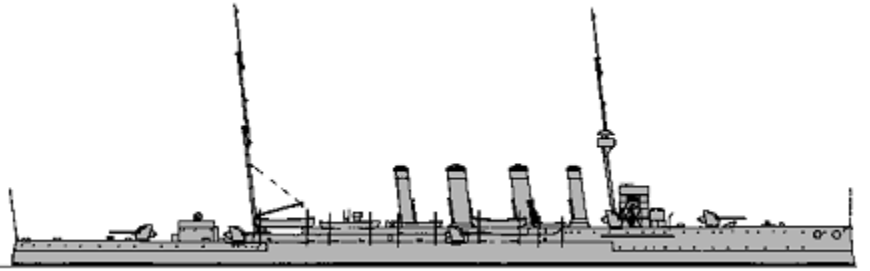
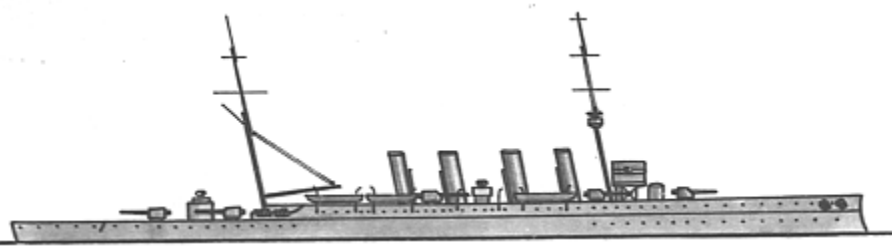
CA	Cressy	2	7	Euryalus	1904		234/47, 12x1-152/45, 12x1-76/40, 3x1-47/40, 2-450TT
	Drake	2	8	Leviathan	1903		14150t, 162.6x21.7x7.9m, 43b,2vte, 30000hp, 23kts, 900p; 152belt, 64deck, 152turrets, 305CT; 2x1-234/47, 16x1-152/45, 14x1-76/40, 3x1-47/40, 2-450TT
			9	King Alfred	1903		
	Monmouth	8	10	Kent	1903		9800t, 141.3x20.1x7.6m, 31b,2vte, 22000hp, 23kts, 678p; 102belt, 51deck, 127turrets, 254CT; (2x2+8x1)-152/45(10-12,14,15), (2x2+10x1)-152/45(13,16,17), 10x1-76/40, 3x1-47/40, 2-450TT
			11	Essex	1904		
12			Lancaster	1904			
13			Donegal	1903			
14			Berwick	1903			
15			Cornwall (TS)	1904			
16			Cumberland	1904			
17	Suffolk (TS)	1904					
Hampshire	4	18	Carnarvon (TS)	1905		10850t, 144.3x20.9x7.3m, 15-17b, 2vte, 21000hp, 22kts, 655p; 152belt, 51deck, 127turrets, 305CT; 4x1-190/45, 6x1-152/45, 2x1-76/40, 18x1-47/50, 2-450TT	
		19	Antrim	1905			
		20	Roxburgh	1905			
		21	Devonshire	1905			
	Duke of Edinburgh	1	22	Duke of Edinburgh	1906		13550t, 154.1x22.4x7.9m, 20b, 2vte, 23000hp, 23kts, 790p; 152belt, 38deck, 190turrets, 254CT; 6x1-234/47, 8x1-152/50, 1x1-76/45, 8x1-47/50, 3-450TT

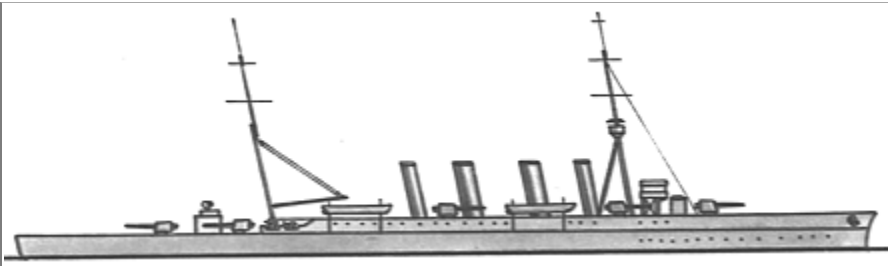
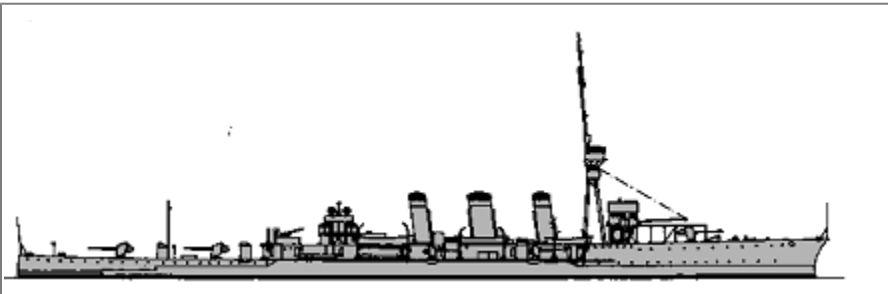
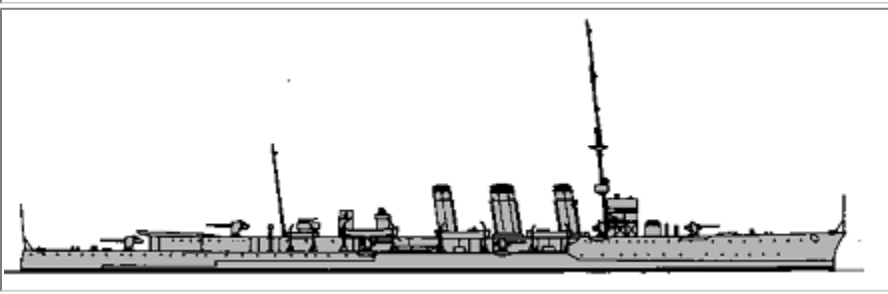
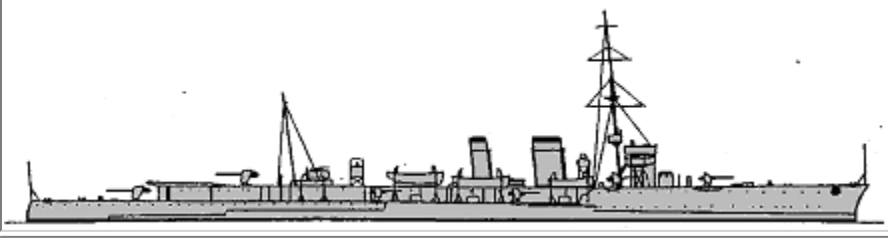
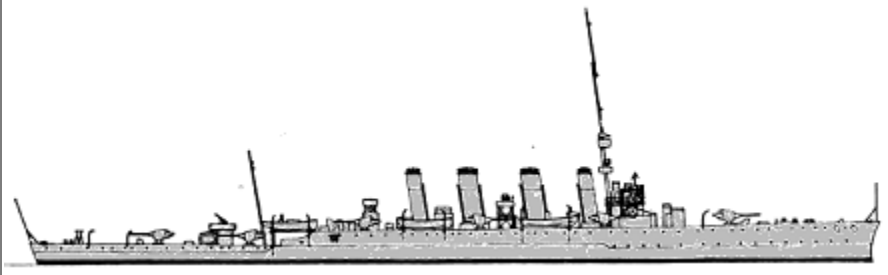
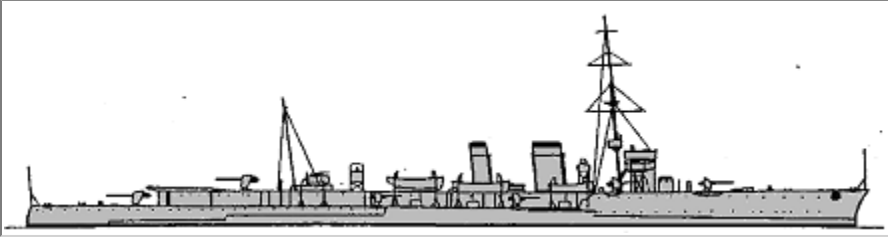

						
Warrior	1	23	Achilles (TS)	1907		13550t, 154.0x22.4x7.6m, 25b,2vte, 23000hp, 23kts, 712p; 152belt, 38deck, 190turrets, 254CT; 6x1-234/47, 4x1-190/50, 1x1-76/45, 10x1-47/50, 3-450TT
Minotaur		24	Minotaur	1908		14600t, 158.2x22.7(24)-23.0(25)x7.9m, 24b,2vte, 27000hp, 23kts, 755p; 152belt, 38deck, 203turrets, 254CT; 2x2-234/50, 10x1-190/50, 16x1-76/50, 2x1-76/45, 5-450TT
		25	Shannon	1908		
Hawkins	1	26	Hawkins	1919		12300t, 184.4x19.8x5.9m, 12b,4gt, 60000hp, 30kts, 712p; 76belt, 38deck, 51gunhouses, 76CT; 7x1-190/45, 6x1-76/50, 4x1-76/45, 4x1-47/40, 2x1-40/39, 6-533TT
Astraea		1	Astraea	1895		4360t, 103.5x15.1x5.8m, 8b,2vte, 9500hp, 19.5kts, 318p; steel: 51deck, 114shields, 76CT; 2x1-152/40, 8x1-120/40, 10x1-57/40, 1x1-47/40, 4-450TT
		2	Fox	1896		

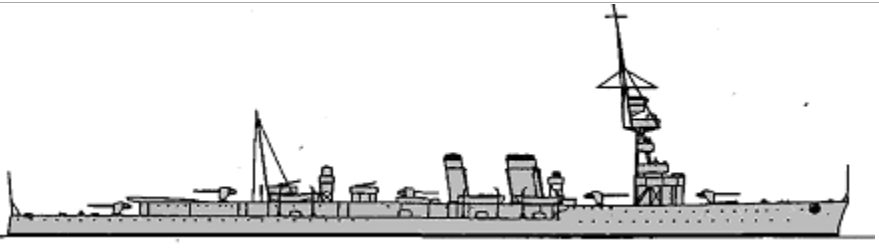
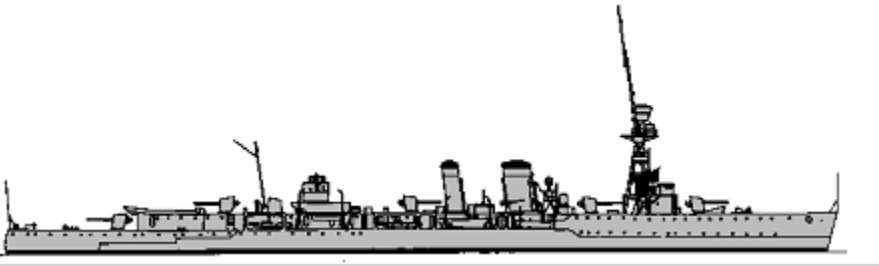
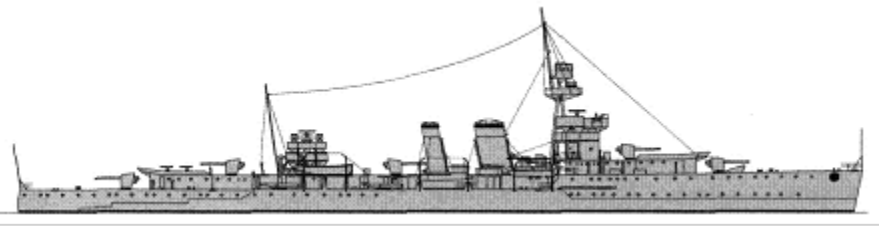

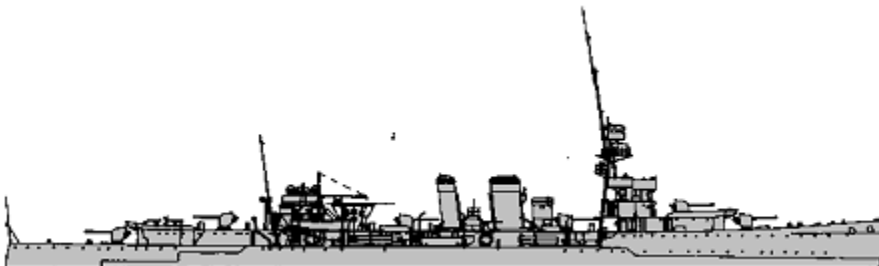
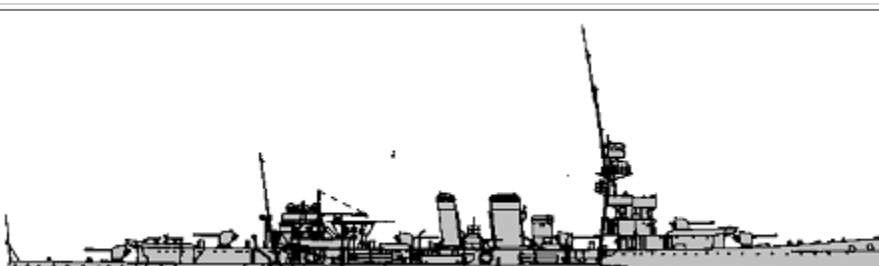
Eclipse	7	3	Talbot	1896		5600t, 113.7x16.3x6.3m, 8b,2vte, 9600hp, 19.5kts, 450p; Harvey: 76deck, 76shields, 152CT; 11x1-152/45, 8x1-76/40, 6x1-47/40, 2x1-11.4, 3-450TT
		4	Venus	1897		
		5	Minerva	1897		
		6	Juno	1897		
		7	Diana	1897		
		8	Isis	1898		
Highflyer	2	9	Highflyer	1899		5650t, 113.4x16.5x6.3m, 18b,2vte, 10000hp, 20kts, 450p; Harvey: 76deck, 76shields, 152CT; 11x1-152/40, 9x1-76/40, 6x1-47/40, 2-450TT
		10	Hyacinth	1900		
Challenger	1	11	Challenger	1904		5880t, 113.4x16.5x6.3m, 18b,2vte, 12500hp, 21kts, 450p; 76deck, 76shields, 152CT; 11x1-152/45, 9x1-76/40, 6x1-47/40, 2-450TT
Bristol	5	12	Glasgow	1910		5300t, 138.1x14.3x4.7m, 12b,4st(12-15)-12b,2st(16), 22000hp, 25kts, 480p; 51deck, 102shields, 51CT; 2x1-152/50, 10x1-102/50, 1x1-76/45, 4x1-47/40, 2-450TT
		13	Gloucester	1910		
		14	Liverpool	1910		
		15	Newcastle	1910		
		16	Bristol	1910		
Weymouth	3	17	Dartmouth	1911		5800t, 138.1x14.6x4.7m, 12b,4st(17,18)-12b,2st(19), 22000hp, 25kts, 475p; 51deck, 102shields, 102CT(18,19); 8x1-152/50, 2x1-76/45(17,18), 1x1-76/45(19), 4x1-47/40, 2-533TT
		18	Weymouth	1911		
		19	Yarmouth	1912		
Chatham	2	20	Dublin	1913		6000t, 139.6x14.9x4.9m, 12b,4st(20)-12b,2st(21), 25000hp, 25.5kts, 475p; 51belt, 38deck, 102shields; 8x1-152/50, 1x1-76/45, 4x1-47/40, 2-533TT
		21	Southampton	1912		

CL	Birmingham	2	22	Lowestoft	1914		6100t, 139.3x15.2x4.9m, 12b,4st, 25000hp, 25.5kts, 480p; 51belt, 38deck, 102shields, 102CT; 9x1-152/45, 1x1-76/45, 4x1-47/40, 2-533TT
			23	Birmingham	1914		
	Arethusa	7	24	Aurora	1914		4400t, 132.9x11.9x4.1m, 8b,4st, 40000hp, 28.5kts, 282p; 76belt, 25deck, 102shields, 76CT; 2x1-152/45(24,25), 3x1-102/45(26-30), 6x1-102/45(24), 4x1-102/45(26,27,29,30), 7x1-102/45(25), 5x1-102/45(28), 2x1-76/45(24,27,29,30), 1x1-76/45(25,26,28), 1x1-47/50(26), 4x2-533TT, 74mines(24,26-30), 1aircraft (Camel)
			25	Undaunted	1914		
			26	Galatea	1914		
			27	Inconstant	1915		
			28	Penelope	1914		
			29	Phaeton	1915		
			30	Royalist	1915		
	Caroline	6	31	Cordelia	1915		4733t, 135.9x12.6x4.9m, 8b,4st, 40000hp, 28.5kts, 301p; 76belt, 25deck, 102shields; 4x1-152/45, 2x1-102/45(35), 1x1-102/45(36), 2x1-76/45(31-34), 4x1-47/40, 2x1-40/39(35,36), 4x2-533TT
32			Caroline	1914			
33			Carysfort	1915			
34			Comus	1915			
35			Cleopatra	1915			
36			Conquest	1915			
Calliope	2	37	Calliope	1915		4695t, 135.9x12.6x4.5m, 6b,4gt(37)-6b,2gt(38), 37500(37)-40000(38)hp, 29.5(37)-29(38)kts, 368p; 102belt, 25deck, 102shields, 152CT; 4x1-152/45, 1x1-102/45(38), 2x1-76/45(37), 4x1-47/40, (2x2+2)-533TT, sweeps(37)	
		38	Champion	1915			
Birkenhead	2	39	Birkenhead	1915		5845(39)-5795(40)t, 135.9(39)-139.1(40)x15.2x4.6(39)-4.7(40)m, 12b,4st, 25000(39)-31000(40)hp, 25.5(39)-26.5(40)kts, 452(39)-402(40)p; 51belt, 38deck, 102shields, 102CT; 10x1-140/50, 1x1-76/45, 2-533TT, 1aircraft(Camel)(39), sweep(40)	
		40	Chester	1916			
Cambrian	4	41	Castor	1915		4799t, 135.9x12.6x4.5m, 6b,4gt, 40000hp, 28.5kts, 368p; 76belt, 25deck, 102shields, 152CT; 4x1-152/45, 1x1-102/45(44), 2x1-76/45(41-43), 4x1-47/40, 2x1-40/39(44), 2-533TT(41,42,44), (4x2+2)-533TT(43)	
		42	Constance	1916			
		43	Canterbury	1916			
		44	Cambrian	1916			
Centaur	2	45	Centaur	1916		4870t, 135.9x12.8x4.1m, 6b,4gt, 40000hp, 29kts, 437p; 76belt, 25deck, 102shields, 152CT; 5x1-152/45,	

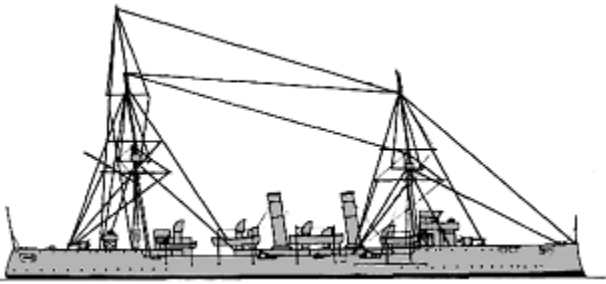
		46	Concord	1916		2x1-76/45, 2x1-40/39, 2-533TT
Caledon	3	47	Caledon	1917		4950t, 137.2x13.0x5.0m, 6b,2gt, 40000hp, 29kts, 400p; 76belt, 25deck, 25shields; 5x1-152/45, 2x1-76/45, 4x1-47/40, 4x2-533TT, 1aircraft(Camel)(47)
		48	Caradoc	1917		
		49	Calypso	1917		
Ceres	5	50	Ceres	1917		5020t, 137.2x13.3x4.5m, 6b,2gt, 40000hp, 29kts, 460p; 76belt, 25deck, 25shields; 5x1-152/45, 2x1-76/45, 4x1-47/40, 2x1-40/39, 4x2-533TT, 1aircraft(Camel)(54)
		51	Cardiff	1917		
		52	Curacoa	1918		
		53	Curlew	1917		
		54	Coventry	1918		
Carlisle	4	55	Carlisle	1918		5250t, 137.6x13.3x4.7m, 6b,2gt, 40000hp, 29kts, 432p; 76belt, 25deck, 25shields; 5x1-152/45, 2x1-76/45, 4x1-47/40, 2x1-40/39, 4x2-533TT, 1aircraft(Camel)(55)
		56	Calcutta	1919		
		57	Cairo	1919		
		58	Colombo	1919		
Danae	3	59	Dragon	1918		5870t, 143.6x13.9x5.0m, 6b,2gt, 40000hp, 29kts, 450p; 76belt, 25deck, 25shields, 76CT; 6x1-152/45, 2x1-76/45, 2x1-40/39, 4x3-533TT, 1aircraft(Camel)
		60	Danae	1918		
		61	Dauntless	1918		
Delhi	2	62	Delhi	1919		5870t, 143.6x13.9x5.0m, 6b,2gt, 40000hp, 29kts, 450p; 76belt, 25deck, 25shields, 76CT; 6x1-152/45, 2x1-76/45, 2x1-40/39, 4x3-533TT
		63	Dunedin	1919		

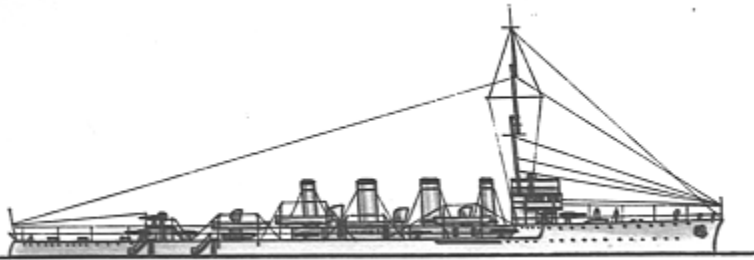
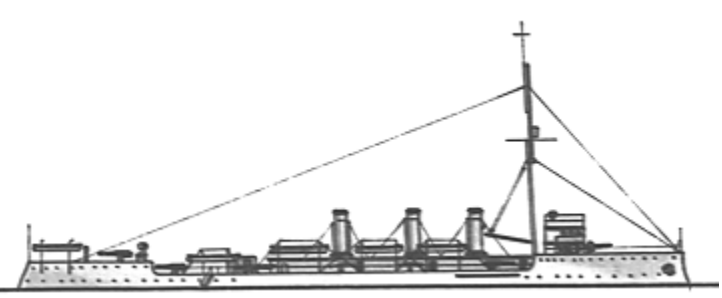
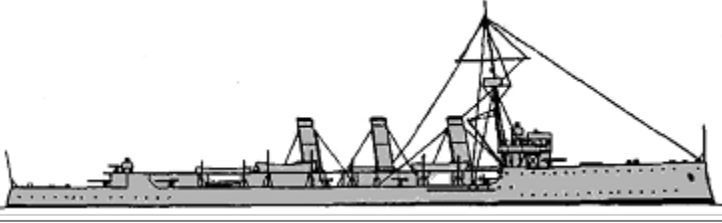
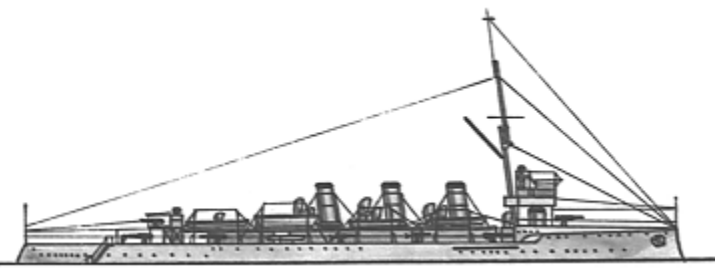

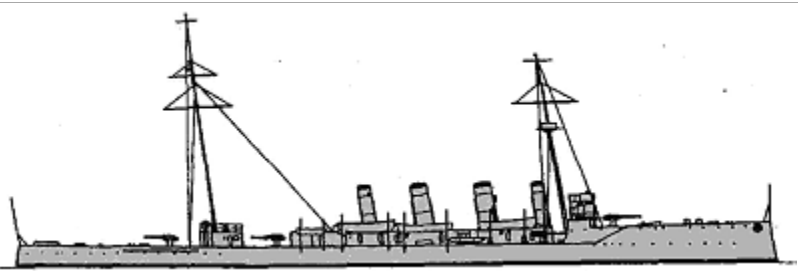
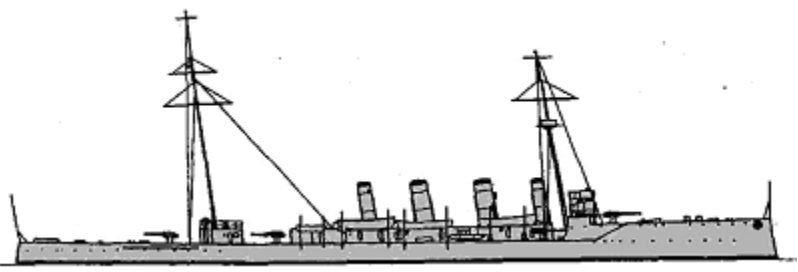
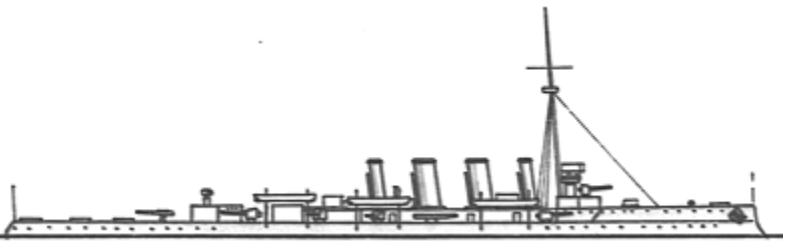







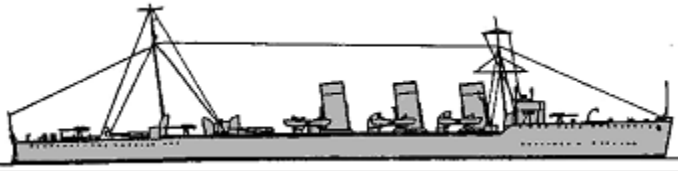
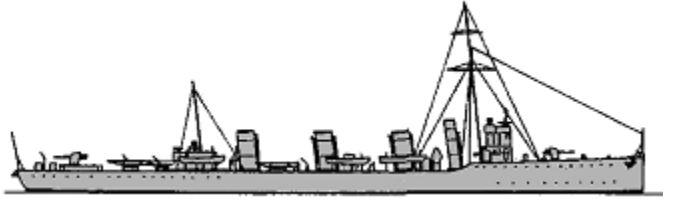
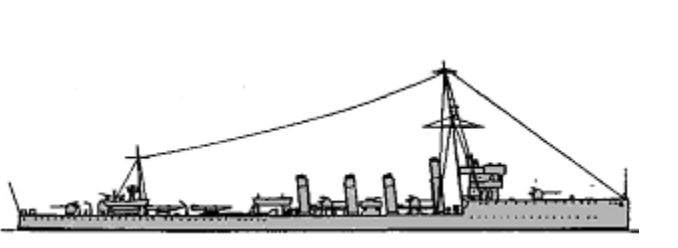
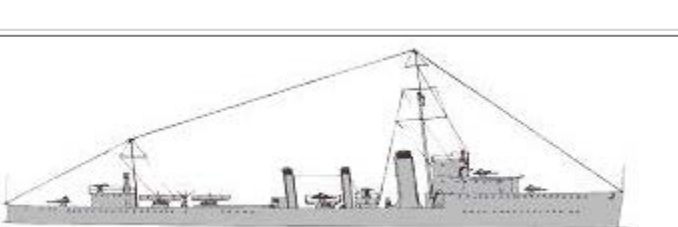
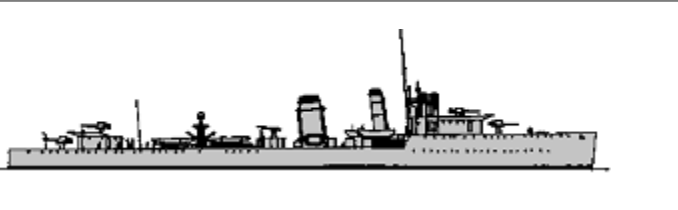
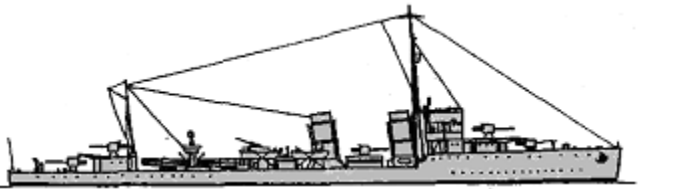
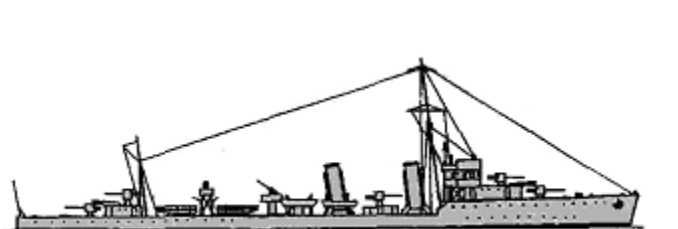





CLL	Pelorus	1	1	Pyramus	1900		2135-2200t, 95.6x11.1x4.9m, 16b,2vte, 7000hp, 20kts, 224p; steel: 51deck, 76shields, 76CT; 8x1-102/40, 8x1-47/40, 3x1-7.7, 2-450TT
	Gem	4	2	Topaze	1904		3000t, 113.9x12.2x4.4m, 10b,2vte(2,4,5)-19b,3st(3), 9800(2,4,5)-12000(3)hp, 21.7(2,4,5)-22.5(3)kts, 296p; 51deck, 25shields, 76CT; 12x1-102/40, 8x1-47/40, 2-450TT, 6 CMB40 MTBs(4)
			3	Amethyst	1905		
			4	Diamond	1905		
			5	Sapphire	1905		
	Adventure	2	6	Adventure	1905		120.4x11.7x3.7m, 12b,2vte, 16000hp, 25kts, 268p; 51deck, 76CT; 2x1-152/45(7), 9x1-102/40(6), 6x1-102/40(7), 1x1-76/45(7), 1x1-57/40(7), 2x1-40/39(7), 2-450TT(6), 2x1-356TT(7)
			7	Attentive	1905		
	Forward	2	8	Forward	1905		2860t, 115.5x12.0x4.3m, 12b,2vte, 16500hp, 25kts, 268p; 51belt, 29deck, 76CT; 9x1-102/40, 1x1-76/45, 2-450TT
			9	Foresight	1905		
	Pathfinder	1	10	Patrol	1905		2900t, 115.5x11.8x4.0m, 12b,2vte, 16500hp, 25kts, 268p; 51belt, 38deck, 76CT; 9x1-102/40, 1x1-76/45, 2x1-450TT
	Sentinel	2	11	Sentinel	1905		2880t, 116.1x12.2x4.3m, 12b,2vte, 17000hp, 25kts, 268p; 38deck, 76CT; 9x1-102/40, 1x1-76/45, 1x1-57/40, 1x1-47/40(11), 2-450TT
			12	Skirmisher	1905		
			13	Boadicea	1909		



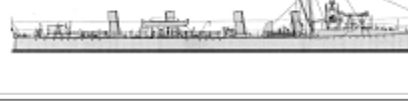



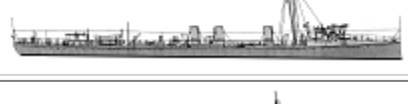

	Boadicea	2	14	Bellona	1910		3800t, 123.4x12.5x4.5m, 12b,4st, 18000hp, 25kts, 317p; 25deck, 102CT; 10x1-102/50(13), 11x1-102/50(14), 1x1-76/45(13), 4x1-47/40, 2x1-450TT, 80mines	
	Blanche	2	15	Blanche	1910		3850t, 123.4x12.6x4.7m, 12b,4st, 18000hp, 24.5kts, 314p; 38deck, 102CT; 11x1-102/50, 4x1-47/40, 2x1-533TT, 66mines	
			16	Blonde	1911			
Active	2	17	Active	1911		4000t, 123.8x12.6x4.7m, 12b,4st, 18000hp, 25kts, 325p; 25deck, 102CT; 8x1-102/50, 1x1-76/45, 4x1-47/40, 2x1-450TT		
		18	Fearless	1913				
SL	Condor	2	1	Vestal	1900		980t, 62.2x9.9x3.5m, 4b,2vte, 1400hp, 13.5kts, 130p; steel: 38deck, 6shields; 6x1-102/40, 4x1-47/40, 3x1-11.4	
			2	Rinaldo	1900			
	Espiegle	4	3	Espiegle	1901			1070t, 64.1x10.1x3.4m, 4b,2vte, 1400hp, 13.2kts, 135p; 38deck, 6shields; 6x1-102/40, 4x1-47/40, 3x1-11.4
			4	Odin	1902			
			5	Clio	1904			
6	Cadmus	1904						
AMC -		7	1	Arlanza	1911		15044brt, 173.8x19.9m, 3vte/st, 17kts; 6x1-152/40, 2x1-57/40	
			2	Changuinola	1912		6011brt, 125.2x15.6m, 2st, 16kts; 6x1-152/40, 2x1-47/40	
			3	Himalaya	1892		6898brt, 141.9x15.9m, 1vte, 18kts; 8x1-120/40	
			4	Ophir	1891		6910brt, 141.7x16.3m, 2vte, 16kts; 8x1-152/40	
			5	Teutonic	1889		9984brt, 172.4x17.6m, 2vte, 20kts; 8x1-152/40, 2x1-57/40	
			6	Victorian	1904		10629brt, 158.5x18.4m, 3st, 18kts; 6x1-152/40	
			7	Virginian	1904		10754brt, 158.6x18.4m, 3st, 18kts; 8x1-152/40, 2x1-57/40	





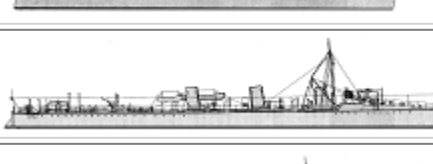
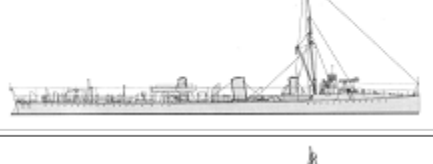

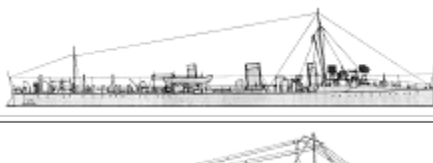

## TORPEDO SHIPS



	Swift	1	1	Swift	1910		2390t, 107.8x10.4x3.2m, 12b,4st, 30000hp, 35kts, 126p; 4x1-102/40, 2x1-450TT, sweep
--	-------	---	---	-------	------	--	---



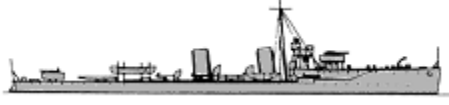
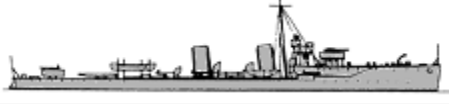
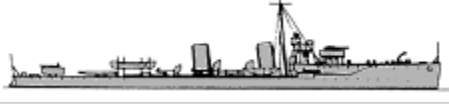
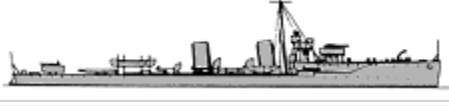
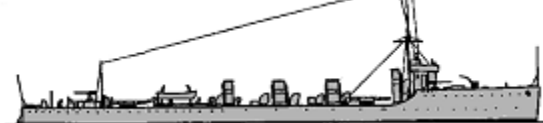



							
DL	Faulknor	3	2	Faulknor	1914		2000t, 100.8x9.9x3.5m, 6b,3rst, 30000hp, 31kts, 197p; 2x1-120/45, 2x1-102/40, 1x1-40/39, 4x1-533TT(2,3), 2x2-533TT(4)
			3	Broke	1914		
			4	Botha	1915		
	Lightfoot	7	5	Nimrod	1915		1700t, 99.0x9.7x3.7m, 4b,3st, 36000hp, 34.5kts,104p; 4x1-102/40(5-8,11), 2x1-102/40(9,10), 1x1-76/45(6-8), 2x1-40/39, 2x2-533TT(5-8,11), 2x1-450TT(5,8), 80mines(9), 60mines(10)
			6	Marksman	1915		
			7	Kempenfelt	1915		
			8	Lightfoot	1915		
			9	Abdiel	1916		
			10	Gabriel	1916		
	Parker	4	11	Ithuriel	1916		1912t, 99.0x9.7x3.7m, 4b,3st, 36000hp, 34kts, 116p; 4x1-102/40(12,13,15), 2x1-102/40(14), 2x1-40/39, 2x2-533TT(12,13,15), 80mines(14)
			12	Parker	1916		
			13	Grenville	1916		
			14	Seymour	1916		
	V	5	15	Saumarez	1916		1400t, 95.1x9.0x3.2m, 3b,2gt, 27000hp, 34kts, 115p; 4x1-102/45, 2x1-40/39, 2x2-533TT(16-18,20), 2x3-533TT(19), 1dcr
			16	Valkyrie	1917		
			17	Valentine	1917		
			18	Valorous	1917		
			19	Vampire	1917		
	Shakespeare	3	20	Valhalla	1917		2000t, 100.3x9.6x3.8m, 4b,2gt, 40000hp, 36kts, 183p; 5x1-120/45, 1x1-76/45, 2x1-40/39, 2x3-533TT, 2dct, 1dcr
			21	Shakespeare	1917		
			22	Spencer	1917		
	Scott	7	23	Wallace	1919		2050t, 101.3x9.7x3.8m, 4b,2gt, 40000hp, 36kts, 164p; 5x1-120/45, 1x1-76/45, 2x1-40/39, 2x3-533TT, 2dct, 1dcr
			24	Bruce	1918		
			25	Douglas	1918		
			26	Montrose	1918		
			27	Stuart	1918		
			28	Campbell	1918		
			29	Mackay	1919		
	30	Malcolm	1919				
	Janus	1	1	Porcupine	1896		320t, 61.1x5.9x2.4m, 4b,2vte, 3900hp, 28kts, 54p; 1x1-76/40, 5x1-57/40, 2x1-450TT

Rocket	1	2	Surly	1895		325t, 62.2x6.0x2.21m, 4b,2vte, 4100hp, 27kts, 58p; 1x1-76/40, 5x1-57/40, 1x1-450TT, 2dcr
Sunfish	3	3	Sunfish	1896		340t, 62.2x5.8x2.6m, 8b,2vte, 4000hp, 27kts, 58p; 1x1-76/40, 5x1-57/40, 2x1-450TT
		4	Opossum	1896		
		5	Ranger	1896		
Desperate	3	6	Desperate	1897		350t, 64.0x6.0x2.1m, 3b,2vte, 5700hp, 30kts, 54p; 1x1-76/40, 5x1-57/40, 2x1-450TT
		7	Fame	1897		
		8	Mallard	1897		
Avon	1	9	Avon	1899		405t, 65.3x6.1x2.5m, 4b,2vte, 6300hp, 30kts, 60p; 1x1-76/40, 5x1-57/40, 2x1-450TT, 2dcr
Earnest	5	10	Earnest	1897		415t, 66.5x6.6x3.0m, 4b,2vte, 6300hp, 30kts, 56p; 1x1-76/40, 5x1-57/40, 2x1-450TT, 2dcr(11-14)
		11	Griffon	1897		
		12	Panther	1898		
		13	Seal	1898		
		14	Wolf	1898		
Angler	1	15	Angler	1898		352t, 64.0x6.0x2.1m, 3b,2vte, 5700hp, 30kts, 54p; 1x1-76/40, 5x1-57/40, 2x1-450TT, 2dcr
Violet	1	16	Violet	1898		400t, 65.2x6.4x2.9m, 4b,2vte, 6300hp, 30kts, 58p; 1x1-76/40, 5x1-57/40, 2x1-450TT, 2dcr
Gipsy	1	17	Gipsy	1898		400t, 65.7x6.5x2.5m, 4b,2vte, 6300hp, 30kts, 60p; 1x1-76/40, 5x1-57/40, 2x1-450TT, 2dcr
Conflict	2	18	Conflict	1899		360t, 62.7x6.1x2.5m, 3b,2vte, 4500hp, 27kts, 54p; 1x1-76/40, 5x1-57/40, 2x1-450TT
		19	Wizard	1899		
Coquette	2	20	Cynthia	1899		367t, 64.0x6.0x2.3m, 3b,2vte, 5700hp, 30kts, 54p; 1x1-76/40, 5x1-57/40, 2x1-450TT
		21	Cygnnet	1900		
Leven	1	22	Leven	1899		420t, 65.7x6.5x2.5m, 4b,2vte, 6100hp, 30kts, 58p; 1x1-76/40, 5x1-57/40, 2x1-450TT, 2dcr
Fervent	2	23	Fervent	1900		320t, 62.4x5.8x2.2m, 2b,2vte, 4000hp, 26kts, 48p; 1x1-76/40, 5x1-57/40, 2x1-450TT, 2dcr
		24	Zephyr	1901		
Brazen	1	25	Electra	1900		425t, 65.2x6.1x2.5m, 4b,2vte, 5800hp, 30.5kts, 60p; 1x1-76/40, 5x1-57/40, 2x1-450TT, 2dcr



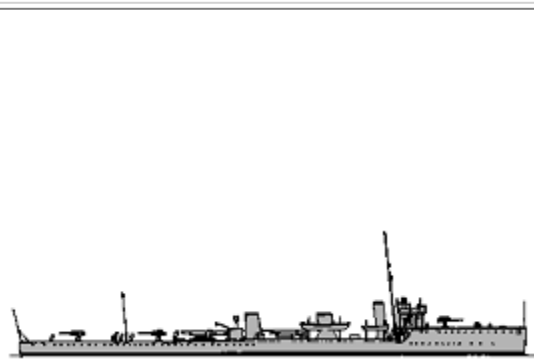

						
Kestrel	1	26	Kestrel	1900		395t, 67.8x6.3x2.7m. 4b,2vte, 5800hp, 30kts, 58p; 1x1-76/40, 5x1-57/40, 2x1-450TT, 2dcr
Spiteful	1	27	Spiteful	1900		450t, 67.1x6.4x2.7m, 4b,2vte, 6200hp, 30kts, 58p; 1x1-76/40, 5x1-57/40, 2x1-450TT, 2dcr
Orwell	1	28	Orwell	1900		410t, 66.0x6.6x2.9m, 4b,2vte, 6300hp, 30kts, 56p; 1x1-76/40, 5x1-57/40, 2x1-450TT, 2dcr
Stag	1	29	Stag	1900		371t, 64.0x6.0x2.2m, 3b,2vte, 5800hp, 30kts, 63p; 1x1-76/40, 5x1-57/40, 2x1-450TT, 2dcr
Albatross	1	30	Albatross	1900		490t, 69.2x6.5x2.8m, 4b,2vte, 7500hp, 31.5kts, 69p; 1x1-76/40, 5x1-57/40, 2x1-450TT
Bullfinch	1	31	Dove	1901		390t, 65.4x6.3x2.4m, 4b,2vte, 5800hp, 30kts, 58p; 1x1-76/40, 5x1-57/40, 2x1-450TT, 2dcr
Myrmidon	1	32	Syren	1902		440t, 67.1x6.4x2.7-2.8m, 4b,2vte, 6300hp, 56p; 1x1-76/40, 5x1-57/40, 2x1-450TT, 2dcr
Falcon	1	33	Ostrich	1901		420t, 65.4x6.5x2.7m, 4b,2vte, 6100hp, 30kts, 58p; 1x1-76/40, 5x1-57/40, 2x1-450TT, 2dcr
Thorn	1	34	Vigilant	1901		425t, 67.7x6.3x2.7m, 4b,2vte, 6400hp, 30kts, 60p; 1x1-76/40, 5x1-57/40, 2x1-450TT, 2dcr
Kangaroo	1	35	Kangaroo	1901		420t, 67.0x6.4x2.7m, 4b,2vte, 6100hp, 30kts, 56p; 1x1-76/40, 5x1-57/40, 2x1-450TT, 2dcr
Greyhound	1	36	Racehorse	1902		430t, 65.4x6.4x4.0m, 4b,2vte, 6100hp, 30kts, 58p; 1x1-76/40, 5x1-57/40, 2x1-450TT, 2dcr

Vixen	1	37	Vixen	1902		445t, 65.7x6.5x2.5m, 4b,2vte, 6300hp, 30kts, 58p; 1x1-76/40, 5x1-57/40, 2x1-450TT, 2dcr
Lively	2	38	Lively	1902		435t, 66.8x6.7x2.6m, 4b,2vte, 6250hp, 30kts, 56p; 1x1-76/40, 5x1-57/40, 2x1-450TT, 2dcr
		39	Sprightly	1902		
Express	1	40	Express	1902		540t, 73.0x7.2x3.1m, 4b,2vte, 9250hp, 31kts, 74p; 1x1-76/40, 5x1-57/40, 2x1-450TT
Erne	1	41	Exe	1904		620t, 71.2x7.2x3.0m, 4b,2vte, 7000hp, 25.5kts, 70p; 1x1-76/40, 3x1-76/28, 2x1-450TT
Usk	2	42	Usk	1904		660t, 70.5x7.2x3.1m, 4b,2vte, 7500hp, 26kts, 70p; 1x1-76/40, 3x1-76/28, 2x1-450TT
		43	Ribble	1904		
Welland	1	44	Welland	1904		660t, 70.5x7.2x3.1m, 4b,2vte, 7500hp, 26kts, 70p; 1x1-76/40, 3x1-76/28, 2x1-450TT
Arun	1	45	Arun	1904		625t, 69.1x7.2x2.9m, 4b,2vte, 7000hp, 25.6kts, 70p; 1x1-76/40, 3x1-76/28, 2x1-450TT
Waveney	1	46	Waveney	1904		620t, 68.7x7.2x2.7m, 4b,2vte, 7000hp, 25.6kts, 70p; 1x1-76/40, 3x1-76/28, 2x1-450TT
Kennet	1	47	Jed	1905		615t, 68.6x7.3x2.8m, 4b,2vte, 7500hp, 25.8kts, 70p; 1x1-76/40, 3x1-76/28, 2x1-450TT
Chelmer	1	48	Chelmer	1905		615t, 68.6x7.3x2.8m, 4b,2vte, 7500hp, 25.8kts, 70p; 1x1-76/40, 3x1-76/28, 2x1-450TT
Tribal-1	1	49	Tartar	1908		1000t, 78.2-84.5x7.5-7.8x3.1m, 6b,3st, 14000hp, 33kts, 68p; 5x1-76/40, 2x1-40/39, 2x1-450TT, 2x1-356TT
Tribal-2	1	50	Crusader	1909		1200t, 85.0-87.6x8.0-8.4x3.1m, 6b,3st, 14000hp, 33kts, 68p; 2x1-102/40, 2x1-40/39, 2x1-450TT, 2x1-356TT
Albacore	1	51	Bonetta	1909		550t, 65.7x6.5x2.2m, 4b,2st, 7000hp, 26.5kts, 56p; 3x1-76/40, 2x1-450TT
		52	Beagle	1910		

G	13	53	Bulldog	1910		<p>1100t, 83.8x8.2-8.6x2.6m, 5b,2st, 14300hp, 27kts, 96p; 1x1-102/40, 3x1-76/40(52-60,62-64), 2x1-76/40(61), 1x1-47/50(52,53,55-60,61,63,64), 2x1-533TT, 1dct(52-58,61-64)</p>
		54	Grasshopper	1910		
		55	Harpy	1910		
		56	Renard	1910		
		57	Foxhound	1910		
		58	Mosquito	1910		
		59	Basilisk	1910		
		60	Scourge	1910		
		61	Scorpion	1910		
		62	Savage	1910		
		63	Rattlesnake	1910		
		64	Grampus	1911		
		H	17	65		
66	Redpole			1911		
67	Acorn			1910		
68	Nemesis			1911		
69	Rifleman			1911		
70	Larne			1911		
71	Alarm			1911		
72	Hope			1911		
73	Nereide			1911		
74	Brisk			1911		
75	Lyra			1911		
76	Ruby			1911		
77	Martin			1911		
78	Sheldrake			1911		
79	Nymphe			1911		
80	Minstrel			1911		
81	Fury			1912		
I-Admiralty	13	82	Ferret	1911		<p>990t, 75.0x7.8x2.7m, 3b,3st, 13500hp, 27kts, 70p; 1x1-102/40(82,84), 2x1-102/40(83,85-94), 2x1-76/40, 1x1-533TT(82,84), 2x1-533TT(83,85-94), 40mines(82,84)</p>
		83	Forester	1912		
		84	Sandfly	1911		
		85	Hind	1911		
		86	Lapwing	1912		
		87	Defender	1912		
		88	Jackal	1912		
		89	Lizard	1912		
		90	Goshawk	1912		
		91	Druid	1912		
		92	Hornet	1912		
		93	Tigress	1912		

		94	Hydra	1912		
I-Yarrow	1	95	Archer	1912		990t, 75.0x7.8x2.7m, 3b,2st, 16000hp, 28kts, 70p; 2x1-102/40, 2x1-76/40, 2x1-533TT
I-Thornycroft	1	96	Acheron	1911		990t, 75.0x7.8x2.7m, 3b,3st, 15500hp, 29kts, 70p; 2x1-102/40, 2x1-76/40, 2x1-533TT
I-Parsons	2	97	Badger	1912		990t, 75.0x7.8x2.7m, 3b,3st, 13500hp, 27kts, 70p; 2x1-102/40, 2x1-76/40, 2x1-533TT
		98	Beaver	1912		
I-Yarrow (Firedrake)	3	99	Firedrake	1912		990t, 75.0x7.8x2.7m, 3b,3st, 20000hp, 32kts, 70p; 2x1-102/40, 2x1-76/40, 2x1-533TT
		100	Lurcher	1912		
		101	Oak	1912		
K	13	102	Christopher	1912		1300t, 81.5x8.2x2.9m, 4b,2st, 24500hp, 29kts, 73p; 3x1-102/40, 1x1-40/39, 2x1-533TT
		103	Acasta	1912		
		104	Cockatrice	1913		
		105	Achates	1913		
		106	Spitfire	1913		
		107	Ambuscade	1913		
		108	Midge	1914		
		109	Owl	1914		
		110	Hardy	1913		
		111	Porpoise	1914		
		112	Unity	1914		
		113	Victor	1914		
		114	Garland	1913		
L	19	115	Laertes	1913		1300t, 81.9x8.5x3.2m, 4b,2st(115-124,131)-3b,2st(125-130)-4b,2gt(132,133), 24500hp, 29kts, 73p; 3x1-102/40, 1x1-40/39, 2x2-533TT, 4mines
		116	Lysander	1913		
		117	Lawford	1914		
		118	Llewellyn	1914		
		119	Loyal	1914		
		120	Legion	1914		
		121	Lance	1914		
		122	Lydiard	1914		
		123	Lennox	1914		
		124	Lookout	1914		
		125	Laurel	1914		

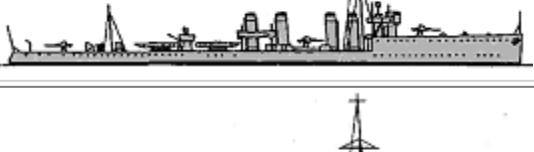

DD		126	Liberty	1914			
		127	Lark	1913			
		128	Linnet	1913			
		129	Laverock	1914			
		130	Landrail	1914			
		131	Lochinvar	1915			
		132	Leonidas	1914			
		133	Lucifer	1914			
	M-Admiralty	6	134	Murray	1914		1100t, 83.3x8.2x2.6m, 4b,3st, 25000hp, 34kts, 80p; 3x1-102/40, 2x1-40/39, 2x2-533TT, 4mines
		135	Myngs	1915			
		136	Matchless	1914			
		137	Milne	1914			
		138	Morris	1914			
		139	Moorsom	1915			
	M-Hawthorn Leslie	2	140	Mentor	1915		1200t, 82.8x8.2x3.2m, 4b,2irst, 27000hp, 35kts, 76p; 3x1-102/40, 2x1-40/39, 2x2-533TT, 4mines
		141	Mansfield	1915			
M-Thornycroft	2	142	Meteor	1914		1100t, 83.6x8.3x3.1m, 4b,2irst, 26500hp, 35kts, 82p; 2x1-102/40(142), 3x1-102/40(143), 2x1-40/39, 2x2-533TT(143), 60mines(142), 4mines(143)	
	143	Mastiff	1914				
M-Yarrow	3	144	Miranda	1914		990t, 82.1x7.8x2.9m, 3b,2st, 23000hp, 35kts, 79p; 3x1-102/40, 2x1-40/39, 2x2-533TT, 4mines	
	145	Minos	1914				
	146	Manly	1914				
Medea	3	147	Melampus	1915		1200t, 83.3x8.2x2.6m, 3b,3st, 25000hp, 32kts, 80p; 3x1-102/40, 1x1-40/39, 2x2-533TT	
	148	Medea	1915				
	149	Melpomene	1915				
		150	Mandate	1915			
		151	Mons	1915			
		152	Marne	1915			
		153	Manners	1915			
		154	Mystic	1915			
		155	Martial	1915			
		156	Maenad	1915			
		157	Magic	1916			
		158	Menace	1916			
		159	Moresby	1916			
		160	Mameluke	1915			
		161	Mindful	1915			



repeat M  
Admiralty



61



162	Marvel	1915
163	Mischief	1915
164	Nonsuch	1916
165	Ossory	1915
166	Ophelia	1916
167	Obedient	1916
168	Opportune	1916
169	Noble	1916
170	Onslaught	1916
171	Oracle	1916
172	Obdurate	1916
173	Onslow	1916
174	Norman	1916
175	Orestes	1916
176	Nizam	1916
177	Orford	1916
178	Nonpareil	1916
179	Orpheus	1916
180	Octavia	1916
181	Northesk	1916
182	Nugent	1917
183	Napier	1916
184	Nicator	1916
185	Paladin	1916
186	Pasley	1916
187	Observer	1916
188	Offa	1916
189	Parthian	1916
190	Orcadia	1916
191	Oriole	1916
192	Norseman	1916
193	Oriana	1916
194	Osiris	1916
195	Oberon	1916
196	Pigeon	1916
197	Plover	1916
198	Medina	1916
199	Pelican	1916
200	Petard	1916
201	Penn	1916
202	Medway	1916



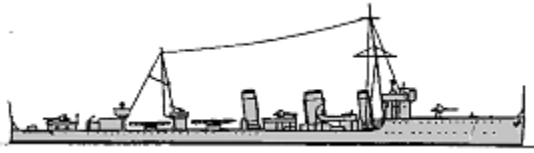





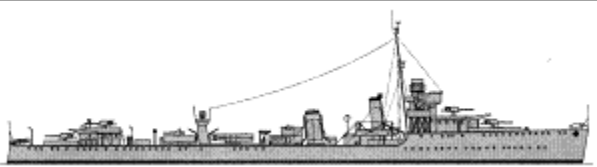

1250t, 83.4x8.2x2.6m, 3b,3gt(150,153,157-159-156,158)-3b,3st(151,152,154-156), 25000hp, 34kts, 80p; 3x1-102/40, 2x1-40/39, 2x2-533TT











		203	Plucky	1916		
		204	Peyton	1916		
		205	Pellew	1916		
		206	Peregrine	1916		
		207	Prince	1916		
		208	Portia	1916		
		209	Pylades	1916		
		210	Phoebe	1916		
repeat M Thornycroft	10	211	Michael	1915		1130t, 83.7x8.4x2.6m, 3b,3st, 26500hp, 80p; 3x1-102/40, 2x1-40/39, 2x2-533TT, 2-356TT
		212	Milbrook	1915		
		213	Minion	1915		
		214	Munster	1916		
		215	Nepean	1916		
		216	Nereus	1916		
		217	Patriot	1916		
		218	Patrician	1916		
		219	Rapid	1916		
		220	Ready	1916		
repeat M Yarrow	7	221	Moon	1915		1008t, 82.2x7.9x2.6m, 3b,2st, 23000hp, 35kts, 80p; 3x1-102/40, 2x1-40/39, 2x2-533TT
		222	Morning Star	1915		
		223	Mounsey	1915		
		224	Musketeer	1915		
		225	Nerissa	1916		
		226	Relentless	1916		
		227	Rival	1916		
Talisman	3	228	Talisman	1916		1300t, 94.2x8.7x2.9m, 3b,3st, 25000hp, 32kts, 102p; 5x1-102/40, 2x2-533TT
		229	Termagant	1916		
		230	Trident	1916		
		231	Romola	1916		
		232	Sarpedon	1916		
		233	Radstock	1916		
		234	Sable	1916		
		235	Rowena	1916		
		236	Rocket	1916		
		237	Raider	1916		
		238	Restless	1916		
		239	Rob Roy	1916		
		240	Sorceress	1916		
		241	Rigorous	1916		

R Admiralty	34	242	Salmon	1916		1244t, 84.1x8.2x2.8m, 3b,2gt, 27000hp, 36kts, 82p; 3x1-102/40, 1x1-40/39, 2x2-533TT
		243	Redoubt	1917		
		244	Sylph	1917		
		245	Redgauntlet	1917		
		246	Sturgeon	1917		
		247	Sceptre	1917		
		248	Starfish	1916		
		249	Stork	1917		
		250	Satyr	1917		
		251	Skate	1917		
		252	Skilful	1917		
		253	Sharpshooter	1917		
		254	Springbok	1917		
		255	Thruster	1917		
		256	Tempest	1917		
		257	Torrid	1917		
		258	Thisbe	1917		
		259	Tarpon	1917		
		R Thornycroft	5	265		
266	Radiant			1917		
267	Retriever			1917		
268	Taurus			1917		
269	Teazer			1917		
R Yarrow	4	270	Sabrina	1916		1051t, 83.4x7.8x2.8m, 3b,3st, 27000hp, 36kts, 82p; 3x1-102/40, 1x1-40/39, 2x2-533TT
		271	Sybill	1917		
		272	Truculent	1917		
		273	Tyrant	1917		
modified R	10	274	Trenchant	1917		1242t, 84.1x8.1x2.8m, 3b,2gt, 27000hp, 36kts, 82p; 3x1-102/40, 1x1-40/39, 2x2-533TT
		275	Tristram	1917		
		276	Undine	1917		
		277	Tower	1917		
		278	Tirade	1917		
		279	Urchin	1917		
280	Umpire	1917				
281	Ursa	1917				
282	Ursula	1917				

		283	Ulster	1917		
V Admiralty	20	284	Vanoc	1917		1523t, 95.1x9.0x3.2m, 3b,2gt, 27000hp, 34kts, 134p; (4x1-102/45, 1x1-76/45, 2x2-533TT, 2dct, 1dcr, sweeps) or (3x1-102/45, 1x1-76/45, 1x2-533TT, 1dcr, 60mines) (284-286,292,293,295,297)
		285	Vimiera	1917		
		286	Vanquisher	1917		
		287	Verdun	1917		
		288	Violent	1917		
		289	Vega	1917		
		290	Vendetta	1917		
		291	Vectis	1917		
		292	Venturous	1917		
		293	Vortigern	1918		
		294	Venetia	1917		
		295	Versatile	1918		
		296	Vivacious	1917		
		297	Velox	1918		
		298	Vesper	1918		
V Thornycroft	2	304	Viceroy	1918		1512t, 95.1x9.4x2.9m, 3b,2gt, 27000hp, 34kts, 134p; 4x1-102/45, 1x1-76/45, 2x2-533TT, 2dct, 1dcr, sweeps
		305	Viscount	1918		
W Admiralty	19	306	Wakeful	1917		1490t, 95.1x9.0x3.2m, 3b,2gt, 27000hp, 34kts, 134p; (4x1-102/45, 1x1-76/45, 2x3-533TT, 2dct, 1dcr, sweeps) or (3x1-102/45, 1x1-76/45, 1x3-533TT, 1dcr, 60mines) (307-309,311,312)
		307	Watchman	1918		
		308	Walker	1918		
		309	Whirlwind	1918		
		310	Winchelsea	1918		
		311	Walrus	1918		
		312	Warwick	1918		
		313	Winchester	1918		
		314	Walpole	1918		
		315	Westcott	1918		
		316	Westminster	1918		
		317	Wrestler	1918		
		318	Wessex	1918		
		319	Wolfhound	1918		
320	Waterhen	1918				
321	Whitley	1918				

		322	Voyager	1918		
		323	Wryneck	1918		
		324	Windsor	1918		
W Thornycroft	2	325	Wolsey	1918		1512t, 95.1x9.4x2.9m, 3b,2gt, 27000hp, 34kts, 134p; 4x1-102/45, 1x1-76/45, 2x3-533TT, 2dct, 1dcr, sweeps
		326	Woolston	1918		
S Admiralty	48	327	Simoom	1918		1225t, 84.1x8.2x2.8m, 3b,2gt, 27000hp, 36kts, 90p; 3x1-102/40, 1x1-40/39, 2x2-533TT, (0-2)x1-450TT, 2dct, 1dcr
		328	Scimitar	1918		
		329	Tribune	1918		
		330	Scotsman	1918		
		331	Senator	1918		
		332	Trinidad	1918		
		333	Shark	1918		
		334	Scout	1918		
		335	Sikh	1918		
		336	Sparrowhawk	1918		
		337	Sepoy	1918		
		338	Sirdar	1918		
		339	Seraph	1918		
		340	Splendid	1918		
		341	Swallow	1918		
		342	Steadfast	1919		
		343	Shamrock	1919		
		344	Somme	1918		
		345	Sabre	1918		
		346	Sterling	1919		
		347	Saladin	1919		
		348	Scythe	1918		
		349	Tilbury	1918		
		350	Seabear	1918		
		351	Trojan	1918		
		352	Tactician	1918		
		353	Tintagel	1918		
		354	Seafire	1918		
355	Searcher	1918				
356	Serapis	1919				
357	Truant	1919				
358	Sportive	1918				
359	Tara	1918				

			360	Tenedos	1919		
			361	Seawolf	1919		
			362	Thanet	1919		
			363	Trusty	1919		
			364	Spear	1918		
			365	Strenuous	1919		
			366	Serene	1919		
			367	Sesame	1919		
			368	Spindrift	1919		
			369	Stonehenge	1919		
			370	Stronghold	1919		
			371	Sardonyx	1919		
			372	Turbulent	1919		
			373	Stormcloud	1919		
			374	Sturdy	1919		
S Thornycroft	5		375	Speedy	1918		1240t, 84.1x8.3x3.2m, 3b,2gt, 27000hp, 36kts, 90p; 3x1-102/40, 1x1-40/39, 2x2-533TT, 2x1-450TT, 2dct, 1dcr
			376	Tobago	1918		
			377	Toreador	1919		
			378	Torbay	1919		
			379	Tourmaline	1919		
S Yarrow	6		380	Torch	1918		1060t, 83.4x7.8x3.1m, 3b,2gt, 27000hp, 36kts, 90p; 3x1-102/40, 1x1-40/39, 2x2-533TT, 2dct, 1dcr
			381	Tomahawk	1918		
			382	Tumult	1918		
			383	Turquoise	1919		
			384	Tuscan	1919		
			385	Tyrian	1919		
modified W Admiralty	10		386	Venomous	1919		1508t, 95.1x9.0x3.2m, 3b,2gt, 27000hp, 34kts, 127p; 4x1-120/45, 2x1-40/39, 2x3-533TT, 2dct, 1dcr
			387	Verity	1919		
			388	Volunteer	1919		
			389	Vansittart	1919		
			390	Wanderer	1919		
			391	Witherington	1919		
			392	Whitshed	1919		
			393	Wivern	1919		
			394	Veteran	1919		
			395	Wild Swan	1919		
TB81	1	1	TB081	1885		137t, 46.9x5.3x2.9m, 2b,1vce, 1330hp, 23.7kts, 25p; 4x1-47/40, (1+2x1)-356TT, 2dcr	
TB26	2	2, 3	TB050, 055	1886 - 1887		60t, 38.9x3.8x2.5m, 1b,1hce, 700-750hp, 19.5-21.5kts, 16p; 1x1-47/40, 2x2-356TT, 1dcr	
TB30	8	4 - 11	TB066-068, 071, 073, 074, 076, 077	1886 - 1887		60t, 38.2x4.0x2.5m, 1b,1hce, 670hp, 19.5kts, 16p; 1x1-47/40, (1+2x2)-356TT, 1dcr	





	TB80	1	12	TB080	1887		105t, 41.2ppx4.3x1.8m, 2b,1vte, 1539hp, 23kts, 21p; 3x1-47/40, (1+1x2)-356TT
	Gurkha	1	13	TB101	1888		92t, 41.2x4.3x2.1m, 2b,1hce, 1000hp, 21.5kts, 18p; 2x2-25/40, (1+2x2)-356TT
	Mahratta	2	14, 15	TB104, 105	1889		95t, 41.2x4.4x2.3m, 2b,1hce, 1000hp, 22kts, 18p; 2x2-25/40, (1+2x2)-356TT
	TB82	4	16 - 19	TB082, 085-087	1889		85t, 39.7ppx4.1x1.8m, 1b,1vte, 1800hp, 23kts, 19p; 3x1-47/40, (1+1x2)-356TT
	TB91	1	20	TB092	1894		141t, 42.8x4.7x2.3m, 1b,1vte, 2350hp, 24.5kts, 18p; 3x1-47/40, (1+1x2)-450TT
	TB97	1	21	TB097	1894		130t, 42.8ppx4.9x2.3m, 2b,2vte, 2000hp, 23kts, 18p; 3x1-47/40, (1+1x2)-450TT
	TB98	4	22	TB098	1901		185t, 50.0x5.2x1.8m, 2b,2vte, 3000hp, 25kts, 32p; 3x1-47/40, 3x1-450TT
23			TB099	1901			
24			TB107	1901			
25			TB108	1901			
	TB109	4	26	TB109	1902		200t, 50.6x5.3x1.7m, 2b,2vte, 3050hp, 25kts, 32p; 3x1-47/40, 3x1-450TT
27			TB110	1902			
28			TB111	1902			
29			TB112	1903			
	TB114	1	30	TB116	1904		219t, 50.3ppx5.3x2.6m, 2b,2vte, 3050hp, 25kts, 32p; 3x1-47/40, 3x1-450TT
TB	Cricket	27	31	TB1	1906		400t, 53.3(79-90)-56.4(91-114)x5.3(79-90)-5.5(91-114)x1.8(79-90)-2.0(91-114)m, 2b,3st, 3750(79-90)-4000(91-114)hp, 26.5(79-90)-26(91-114)kts, 35p; 2x1-76/40, 3x1-450TT
			32	TB2	1907		
			33	TB3	1907		
			34	TB4	1907		
			35	TB5	1907		
			36	TB6	1906		
			37	TB7	1907		
			38	TB8	1907		
			39	TB14	1908		
			40	TB15	1908		
			41	TB16	1908		
			42	TB18	1908		
			43	TB19	1908		
			44	TB20	1908		
			45	TB21	1909		
			46	TB22	1909		
			47	TB23	1908		
48	TB25	1909					
49	TB26	1909					











		50	TB27	1909
		51	TB28	1909
		52	TB31	1909
		53	TB32	1909
		54	TB33	1909
		55	TB34	1909
		56	TB35	1909
		57	TB36	1909



## SUBMARINES

A	8	1	A2	1904		165/180(1,2)-180/207(3-8)t, 30.5(1,2)-30.2(3-8)x3.5(1,2)-3.9(3-8)x3.1m, 1pe/em(1-7), 1d/em(8), 450/80(1,2)-550/150(3-7)-400/150(8)hp, 11.5/7(1,2)-12/8(3-7)-11/8(8)kts, 11(1,2)-13(3-8)p, 30m; 2-450TT
		2	A4	1904		
		3	A5	1905		
		4	A6	1905		
		5	A9	1905		
		6	A11	1905		
		7	A12	1905		
		8	A13	1908		
B	2	9	B1	1904		287/316t, 43.3x4.1x3.4m, 1pe/em, 600/290hp, 12/6kts, 15p, 30m; 2-450TT
		10	B5	1906		
C	21	11	C1	1906		290/320t, 43.4x4.1x3.5m, 1pe/em, 600/300hp, 13/7.5kts, 16p, 30m; 2-450TT
		12	C2	1906		
		13	C4	1907		
		14	C8	1907		
		15	C9	1907		
		16	C10	1907		
		17	C12	1908		
		18	C13	1908		
		19	C14	1908		
		20	C15	1908		
		21	C16	1908		
		22	C18	1909		
		23	C19	1909		
24	C20	1910				
25	C21	1909				
26	C22	1909				
27	C23	1909				
28	C24	1909				
29	C25	1909				
30	C28	1909				

		31	C30	1909		
D	3	32	D4	1911		495/620t, 50.2x6.2x3.5m, 2d/em, 1200/550hp, 14/9kts, 25p, 30m; 3-450TT
		33	D7	1911		
		34	D8	1912		
E	2	35	E2	1913		655/796t, 54.2x6.9x3.8m, 2d/em, 1600/840hp, 15/9kts, 30p, 30m; 1x1-102/40(35), 1x1-57/40(36), 4-450TT
		36	E4	1913		
E9	28	37	E11	1914		667/807t, 55.2x4.6x3.8m, 2d/em, 1600/840hp, 15/9kts, 31p, 30m; 1x1-102/50(58), 1x1-102/40(37,38,40,42), 1x1-76/50(57), 1x1-76/28(41,43-56,59-64), (0-1)x1-40/37, 5-450TT(37-51,53-55,58,60-64), 3-450TT(52,56,57,59), 20mines(52,56,57,59)
		38	E12	1914		
		39	E13	1914		
		40	E21	1915		
		41	E23	1915		
		42	E25	1915		
		43	E27	1917		
		44	E29	1915		
		45	E31	1915		
		46	E32	1916		
		47	E33	1916		
		48	E35	1916		
		49	E38	1916		
		50	E39	1916		
		51	E40	1917		
		52	E41	1916		
		53	E42	1916		
		54	E43	1916		
		55	E44	1917		
		56	E45	1916		
		57	E46	1916		
		58	E48	1917		
		59	E51	1917		
		60	E52	1917		
		61	E53	1916		
		62	E54	1916		
		63	E55	1916		
		64	E56	1916		
V	4	65	V1	1915		386/453(65,66)-391/457(67,68)t, 43.9(65,66)-45.0(67,68)x5.0x3.5m, 2d/em, 900/450(65,66)-900/380(67,68)hp, 14/8.5kts, 20p, 30m; 2-450TT
		66	V2	1915		
		67	V3	1916		
		68	V4	1916		
F	3	69	F1	1915		363/525t, 46.0x4.9x3.2m, 2d/em, 900/400hp, 14/8.7kts, 19p, 30m; 3-450TT
		70	F2	1917		
		71	F3	1916		

SS	G	10	72	G1	1915		703/837t, 57.0x6.9x4.1m, 2d/em, 1600/840hp, 14.5/9kts, 30p, 30m; 1x1-76/28(72), 1x1-76/30(73-81), (0-1)x1-40/37, 1-533TT, 4-450TT
			73	G2	1916		
			74	G3	1916		
			75	G4	1916		
			76	G5	1916		
			77	G6	1916		
			78	G10	1916		
			79	G12	1916		
			80	G13	1916		
			81	G14	1917		
	H1	8	82	H1	1915		364/434t, 45.8x4.7x3.8m, 2d/em, 480/620hp, 13/11kts, 22p, 30m; 4-450TT
			83	H2	1915		
			84	H4	1915		
			85	H7	1915		
			86	H8	1915		
			87	H9	1915		
			88	H11	1917		
			89	H12	1917		
	K	14	90	K2	1917		1980/2566t, 100.6x8.1x5.2m, 2b,2gt/em, 10500/1440hp, 24/9.5kts, 59p, 50m; 1x1-102/40, 1x1-76/45, 8-450TT
			91	K3	1916		
			92	K5	1917		
			93	K6	1917		
			94	K7	1917		
			95	K8	1917		
			96	K9	1917		
			97	K10	1917		
			98	K11	1917		
			99	K12	1917		
			100	K14	1917		
			101	K15	1918		
			102	K16	1918		
			103	K22	1917		
	N	1	104	N1	1917		1441/2026t, 78.8x7.9x5.4m, 2d/em, 3700/1000hp, 17/10kts, 42p, 30m; 1x1-76/30, 8-450TT
	L1	8	105	L1	1917		891/1074t, 70.4x7.2x4.0m, 2d/em, 2400/1600hp, 17/10.5kts, 35p, 50m; 1x1-102/41(105,107,110), 1x1-102/40(106,108,109,111,112), 6-450TT
			106	L2	1917		
			107	L3	1918		
			108	L4	1918		
			109	L5	1918		
			110	L6	1918		

		111	L7	1917		
		112	L8	1918		
M	1	113	M1	1918		1594/1946t, 90.2x7.6x4.8m, 2d/em, 2400/1600hp, 15/9kts, 65p, 30m; 1x1-305/40, 1x1-76/45, 4-450TT
H21	21	114	H21	1918		423/510t, 52.4x4.8x4.0m, 2d/em, 480/620hp, 11.5/10.5kts, 22p, 30m; 4-533TT
		115	H22	1918		
		116	H23	1918		
		117	H24	1918		
		118	H25	1918		
		119	H26	1918		
		120	H27	1919		
		121	H28	1918		
		122	H29	1918		
		123	H30	1918		
		124	H31	1919		
		125	H32	1919		
		126	H33	1919		
		127	H34	1919		
128	H42	1919				
129	H43	1919				
130	H47	1919				
131	H48	1919				
132	H49	1919				
133	H51	1919				
134	H52	1919				
R	10	135	R1	1918		410/503t, 49.9x4.7x3.5m, 1d/em, 240/1200hp, 9.5/15kts, 22p, 75m; 6-450TT
		136	R2	1918		
		137	R3	1919		
		138	R4	1919		
		139	R7	1918		
		140	R8	1918		
		141	R9	1918		
		142	R10	1919		
		143	R11	1918		
		144	R12	1918		
		145	L9	1918		
		146	L11	1918		
		147	L12	1918		
		148	L14	1918		
		149	L15	1918		

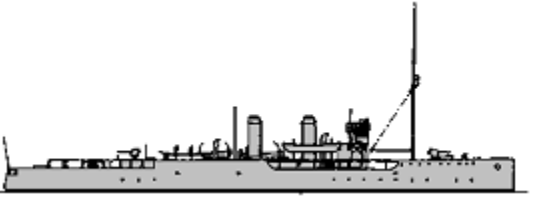
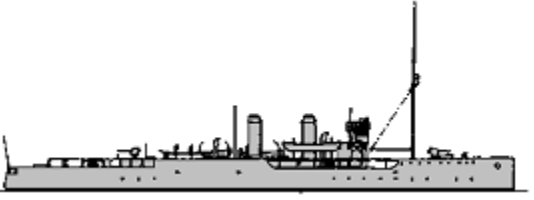

L9	11	150	L16	1918		890/1080t, 72.7x7.2x4.0m, 2d/em, 2400/1600hp, 17/10.5kts, 38p, 50m; 1x1-102/45(155), 1x1-102/41(147), 1x1-102/40(145,146,148,150-154), 1x1-76/45(149), 4-533TT, 2-450TT(145,149,150,152-155), 16mines(146-148,151)
		151	L17	1918		
		152	L18	1919		
		153	L19	1919		
		154	L20	1919		
		155	L33	1919		
L50	1	156	L56	1919		960/1150t, 71.6x7.2x4.0m, 2d/em, 2400/1600hp, 17/10.5kts, 44p, 50m; 2x1-102/40, 6-533TT

## ESCORTS

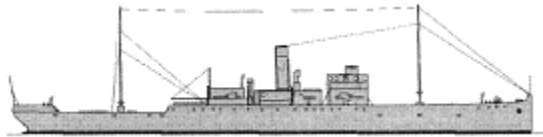
Acacia	21	1	Foxglove	1915		1275t, 80.0x10.1x3.4m, 2b,1vte, 1800hp, 16.5kts, 90p; 2x1-102/40(19), 2x1-76/40(1-18,20,21), 2x1-47/40, 2dct, 1dcr, sweeps
		2	Acacia	1915		
		3	Dahlia	1915		
		4	Honeysuckle	1915		
		5	Lilac	1915		
		6	Hollyhock	1915		
		7	Larkspur	1915		
		8	Jonquil	1915		
		9	Anemone	1915		
		10	Daphne	1915		
		11	Marigold	1915		
		12	Veronica	1915		
		13	Sunflower	1915		
		14	Iris	1915		
		15	Laburnum	1915		
		16	Lily	1915		
		17	Magnolia	1915		
		18	Primrose	1915		
		19	Mimosa	1915		
		20	Bluebell	1915		
		21	Daffodil	1915		
Azalea	9	22	Clematis	1915		1275t, 80.0x10.1x3.4m, 2b,1vte, 1800hp, 16.5kts, 90p; 2x1-120/40 or 2x1-102/44 or 2x1/102/45 or 2x1-102/40, 2x1-47/40, 2dct, 1dcr, sweeps
		23	Zinnia	1915		
		24	Carnation	1915		
		25	Jessamine	1915		
		26	Heliotrope	1915		
		27	Azalea	1915		
		28	Narcissus	1915		

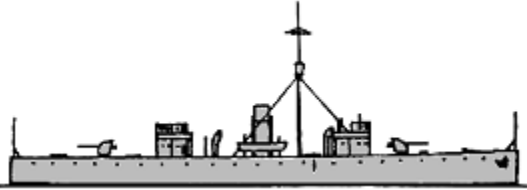
		29	Camellia	1915			
		30	Snowdrop	1915			
SL	Arabis	31	Buttercup	1915		1350t, 81.7x10.2x3.4m, 2b,1vte, 2000hp, 16kts, 104p; 2x1-120/40 or 2x1-102/44 or 2x1-102/45 or 2x1-102/40, 2x1-47/40, 2dct, 1dcr, sweeps	
		32	Gladiolus	1915			
		33	Wallflower	1916			
		34	Poppy	1915			
		35	Verbena	1916			
		36	Rosemary	1915			
		37	Wisteria	1916			
		38	Amaryllis	1916			
		39	Nigella	1916			
		40	Asphodel	1916			
		41	Snapdragon	1916			
		42	Delphinium	1916			
		43	Crocus	1916			
		27	44	Campanula			1916
		45	Godetia	1916			
		46	Pansy	1916			
		47	Berberis	1916			
		48	Pentstemon	1916			
		49	Celandine	1916			
		50	Valerian	1916			
		51	Cyclamen	1916			
		52	Hydrangea	1916			
		53	Lobelia	1916			
		54	Cornflower	1916			
		55	Petunia	1916			
		56	Myosotis	1916			
		57	Lupin	1916			
Aubrietia	6	58	Tamarisk	1916		1450t, 81.7x10.2x3.4m, 2b,1vte, 2500hp, 17.5kts, 92p; 2x1-102/40 or 2x1-102/44 or 2x1-102/45, 1x1-47/40, 2dct, 1dcr	
		59	Heather	1916			
		60	Aubrietia	1916			
		61	Viola	1916			
		62	Lychnis	1917			
		63	Montbretia	1917			
		64	Polyanthus	1917			
65	Hibiscus	1918					
		66	Convolvulus	1917			
		67	Ceanothus	1917			
		68	Eglantine	1917			
		69	Syringa	1917			

				<table border="1"> <tbody> <tr><td>70</td><td>Spiraea</td><td>1917</td></tr> <tr><td>71</td><td>Coreopsis</td><td>1917</td></tr> <tr><td>72</td><td>Auricula</td><td>1917</td></tr> <tr><td>73</td><td>Sweetbriar</td><td>1917</td></tr> <tr><td>74</td><td>Bryony</td><td>1917</td></tr> <tr><td>75</td><td>Ivy</td><td>1918</td></tr> <tr><td>76</td><td>Chrysanthemum</td><td>1918</td></tr> <tr><td>77</td><td>Tuberose</td><td>1918</td></tr> <tr><td>78</td><td>Mistletoe</td><td>1918</td></tr> <tr><td>79</td><td>Dianthus</td><td>1917</td></tr> <tr><td>80</td><td>Marjoram</td><td>1918</td></tr> <tr><td>81</td><td>Gardenia</td><td>1918</td></tr> <tr><td>82</td><td>Saxifrage</td><td>1918</td></tr> <tr><td>83</td><td>Silene</td><td>1918</td></tr> <tr><td>84</td><td>Gilia</td><td>1918</td></tr> <tr><td>85</td><td>Pelargonium</td><td>1918</td></tr> <tr><td>86</td><td>Windflower</td><td>1918</td></tr> <tr><td>87</td><td>Harebell</td><td>1918</td></tr> </tbody> </table>	70	Spiraea	1917	71	Coreopsis	1917	72	Auricula	1917	73	Sweetbriar	1917	74	Bryony	1917	75	Ivy	1918	76	Chrysanthemum	1918	77	Tuberose	1918	78	Mistletoe	1918	79	Dianthus	1917	80	Marjoram	1918	81	Gardenia	1918	82	Saxifrage	1918	83	Silene	1918	84	Gilia	1918	85	Pelargonium	1918	86	Windflower	1918	87	Harebell	1918		<p>1493t, 80.0x10.7x3.5m, 2b,1vte, 2500hp, 17.5kts, 119p; 2x1-102/40 or 2x1-102/44 or 2x1-102/45, 2x1-76/40, 2dct, 2dcr</p>									
70	Spiraea	1917																																																																			
71	Coreopsis	1917																																																																			
72	Auricula	1917																																																																			
73	Sweetbriar	1917																																																																			
74	Bryony	1917																																																																			
75	Ivy	1918																																																																			
76	Chrysanthemum	1918																																																																			
77	Tuberose	1918																																																																			
78	Mistletoe	1918																																																																			
79	Dianthus	1917																																																																			
80	Marjoram	1918																																																																			
81	Gardenia	1918																																																																			
82	Saxifrage	1918																																																																			
83	Silene	1918																																																																			
84	Gilia	1918																																																																			
85	Pelargonium	1918																																																																			
86	Windflower	1918																																																																			
87	Harebell	1918																																																																			
				<table border="1"> <tbody> <tr><td>88</td><td>Flying Fox</td><td>1918</td></tr> <tr><td>89</td><td>Silvio</td><td>1918</td></tr> <tr><td>90</td><td>Donovan</td><td>1918</td></tr> <tr><td>91</td><td>Sir Bevis</td><td>1918</td></tr> <tr><td>92</td><td>Ard Patrick</td><td>1918</td></tr> <tr><td>93</td><td>Ormonde</td><td>1918</td></tr> <tr><td>94</td><td>Sanfoin</td><td>1918</td></tr> <tr><td>95</td><td>Sefton</td><td>1918</td></tr> <tr><td>96</td><td>Rocksand</td><td>1918</td></tr> <tr><td>97</td><td>Cicero</td><td>1918</td></tr> <tr><td>98</td><td>Iroquois</td><td>1918</td></tr> <tr><td>99</td><td>Ladas</td><td>1918</td></tr> <tr><td>100</td><td>Spearmint</td><td>1918</td></tr> <tr><td>101</td><td>Bend Or</td><td>1919</td></tr> <tr><td>102</td><td>Orby</td><td>1918</td></tr> <tr><td>103</td><td>Harvester</td><td>1919</td></tr> <tr><td>104</td><td>Sir Visto</td><td>1919</td></tr> <tr><td>105</td><td>Merry Hampton</td><td>1919</td></tr> <tr><td>106</td><td>Persimmon</td><td>1919</td></tr> <tr><td>107</td><td>Isinglass</td><td>1919</td></tr> <tr><td>108</td><td>Minoru</td><td>1919</td></tr> </tbody> </table>	88	Flying Fox	1918	89	Silvio	1918	90	Donovan	1918	91	Sir Bevis	1918	92	Ard Patrick	1918	93	Ormonde	1918	94	Sanfoin	1918	95	Sefton	1918	96	Rocksand	1918	97	Cicero	1918	98	Iroquois	1918	99	Ladas	1918	100	Spearmint	1918	101	Bend Or	1919	102	Orby	1918	103	Harvester	1919	104	Sir Visto	1919	105	Merry Hampton	1919	106	Persimmon	1919	107	Isinglass	1919	108	Minoru	1919		<p>1493t, 81.5x10.7x3.2m, 2b,1vte, 2500hp, 17kts, 82p; 2x1-102/40 or 2x1-102/44 or 2x1-102/45, 2dct, 2dcr, sweeps</p>
88	Flying Fox	1918																																																																			
89	Silvio	1918																																																																			
90	Donovan	1918																																																																			
91	Sir Bevis	1918																																																																			
92	Ard Patrick	1918																																																																			
93	Ormonde	1918																																																																			
94	Sanfoin	1918																																																																			
95	Sefton	1918																																																																			
96	Rocksand	1918																																																																			
97	Cicero	1918																																																																			
98	Iroquois	1918																																																																			
99	Ladas	1918																																																																			
100	Spearmint	1918																																																																			
101	Bend Or	1919																																																																			
102	Orby	1918																																																																			
103	Harvester	1919																																																																			
104	Sir Visto	1919																																																																			
105	Merry Hampton	1919																																																																			
106	Persimmon	1919																																																																			
107	Isinglass	1919																																																																			
108	Minoru	1919																																																																			
	S1	1	1	Swordfish	1916	<p>1105t, 70.5x7.0x4.6m, 1b,2gt, 4000hp, 18kts, 42p; 1x1-102/40, 1x1-76/40, 2dcr</p>																																																															

						
P-boat	42	2	P11	1916		
		3	P75	1916		
		4	P14	1916		
		5	P15	1916		
		6	P16	1916		
		7	P17	1916		
		8	P18	1916		
		9	P19	1916		
		10	P20	1916		
		11	P21	1916		
		12	P22	1916		
		13	P23	1916		
		14	P24	1916		
		15	P25	1916		
		16	P27	1916		
		17	P28	1916		
		18	P29	1916		
		19	P30	1916		
		20	P31	1916		
		21	P32	1916		
		22	P33	1916		
		23	P34	1916		
		24	P35	1917		
		25	P36	1916		
		26	P37	1916		
		27	P38	1917		
		28	P39	1917		
		29	P40	1916		
		30	P41	1917		
		31	P45	1917		
		32	P46	1917		
		33	P47	1917		
		34	P48	1917		
		35	P49	1917		
		36	P50	1916		
		37	P52	1916		
		38	P53	1917		
		39	P54	1917		



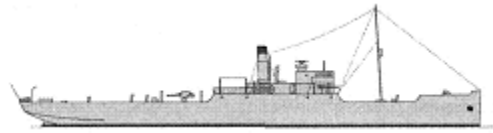

PS		40	P57	1917			
		41	P58	1918			
		42	P59	1918			
		43	P64	1917			
	PC-boat	20	44	PC42	1917		780t, 75.3x7.8(44-53)-8.2(54-63)x2.4m, 2b,2st, 3500hp, 20kts, 55p; 1x1-102/40, 2x1-76/40, 2x1-356TT, 2dcr
			45	PC43	1917		
			46	PC44	1917		
			47	PC51	1917		
			48	PC55	1917		
			49	PC56	1917		
			50	PC60	1917		
			51	PC61	1917		
			52	PC62	1917		
			53	PC63	1917		
			54	PC65	1917		
			55	PC66	1918		
			56	PC67	1917		
			57	PC68	1917		
			58	PC69	1918		
			59	PC70	1918		
			60	PC71	1918		
			61	PC72	1918		
			62	PC73	1918		
			63	PC74	1918		
		64	Kildary	1917			
		65	Kildorough	1917			
		66	Kilfenora	1918			
		67	Kilgobnet	1918			
		68	Kilclare	1918			
		69	Kilchrenan	1918			
		70	Kildavin	1918			
		71	Kildorrey	1918			
		72	Kilfullert	1918			
		73	Kilkeel	1918			
74		Kilcock	1918				
75		Kildimo	1918				
76		Kildysart	1918				
77		Kildysart	1918				
78		Kilgarvan	1918				
79		Kilchreest	1918				
80		Kilham	1918				



	Kil	50	<table border="1"> <tr><td>81</td><td>Kilberry</td><td>1918</td></tr> <tr><td>82</td><td>Kilbeggan</td><td>1918</td></tr> <tr><td>83</td><td>Kilbirnie</td><td>1919</td></tr> <tr><td>84</td><td>Kilbride</td><td>1918</td></tr> <tr><td>85</td><td>Kilburn</td><td>1918</td></tr> <tr><td>86</td><td>Kilchattan</td><td>1918</td></tr> <tr><td>87</td><td>Kilchvan</td><td>1918</td></tr> <tr><td>88</td><td>Kilclief</td><td>1919</td></tr> <tr><td>89</td><td>Kilclogher</td><td>1919</td></tr> <tr><td>90</td><td>Kildalkey</td><td>1918</td></tr> <tr><td>91</td><td>Kildangan</td><td>1918</td></tr> <tr><td>92</td><td>Kildare</td><td>1918</td></tr> <tr><td>93</td><td>Kilfinny</td><td>1918</td></tr> <tr><td>94</td><td>Killena</td><td>1918</td></tr> <tr><td>95</td><td>Killerig</td><td>1918</td></tr> <tr><td>96</td><td>Killiney</td><td>1918</td></tr> <tr><td>97</td><td>Killour</td><td>1918</td></tr> <tr><td>98</td><td>Killowen</td><td>1918</td></tr> <tr><td>99</td><td>Killybegs</td><td>1918</td></tr> <tr><td>100</td><td>Killygordon</td><td>1918</td></tr> <tr><td>101</td><td>Kilmalcolm</td><td>1918</td></tr> <tr><td>102</td><td>Kilmacrennan</td><td>1918</td></tr> <tr><td>103</td><td>Kilmaine</td><td>1918</td></tr> <tr><td>104</td><td>Kilmallock</td><td>1919</td></tr> <tr><td>105</td><td>Kilmanahan</td><td>1919</td></tr> <tr><td>106</td><td>Kilmarnock</td><td>1919</td></tr> <tr><td>107</td><td>Kilmartin</td><td>1919</td></tr> <tr><td>108</td><td>Kilmead</td><td>1919</td></tr> <tr><td>109</td><td>Kilmelford</td><td>1919</td></tr> <tr><td>110</td><td>Kilmersdon</td><td>1919</td></tr> <tr><td>111</td><td>Kilmington</td><td>1919</td></tr> <tr><td>112</td><td>Kilmore</td><td>1919</td></tr> <tr><td>113</td><td>Kilmuckridge</td><td>1919</td></tr> </table>	81	Kilberry	1918	82	Kilbeggan	1918	83	Kilbirnie	1919	84	Kilbride	1918	85	Kilburn	1918	86	Kilchattan	1918	87	Kilchvan	1918	88	Kilclief	1919	89	Kilclogher	1919	90	Kildalkey	1918	91	Kildangan	1918	92	Kildare	1918	93	Kilfinny	1918	94	Killena	1918	95	Killerig	1918	96	Killiney	1918	97	Killour	1918	98	Killowen	1918	99	Killybegs	1918	100	Killygordon	1918	101	Kilmalcolm	1918	102	Kilmacrennan	1918	103	Kilmaine	1918	104	Kilmallock	1919	105	Kilmanahan	1919	106	Kilmarnock	1919	107	Kilmartin	1919	108	Kilmead	1919	109	Kilmelford	1919	110	Kilmersdon	1919	111	Kilmington	1919	112	Kilmore	1919	113	Kilmuckridge	1919		895t, 55.5x9.2x3.2m, 1b,1vte, 1400hp, 13kts, 39p; 1x1-102/44, 2dcr or sweeps
81	Kilberry	1918																																																																																																						
82	Kilbeggan	1918																																																																																																						
83	Kilbirnie	1919																																																																																																						
84	Kilbride	1918																																																																																																						
85	Kilburn	1918																																																																																																						
86	Kilchattan	1918																																																																																																						
87	Kilchvan	1918																																																																																																						
88	Kilclief	1919																																																																																																						
89	Kilclogher	1919																																																																																																						
90	Kildalkey	1918																																																																																																						
91	Kildangan	1918																																																																																																						
92	Kildare	1918																																																																																																						
93	Kilfinny	1918																																																																																																						
94	Killena	1918																																																																																																						
95	Killerig	1918																																																																																																						
96	Killiney	1918																																																																																																						
97	Killour	1918																																																																																																						
98	Killowen	1918																																																																																																						
99	Killybegs	1918																																																																																																						
100	Killygordon	1918																																																																																																						
101	Kilmalcolm	1918																																																																																																						
102	Kilmacrennan	1918																																																																																																						
103	Kilmaine	1918																																																																																																						
104	Kilmallock	1919																																																																																																						
105	Kilmanahan	1919																																																																																																						
106	Kilmarnock	1919																																																																																																						
107	Kilmartin	1919																																																																																																						
108	Kilmead	1919																																																																																																						
109	Kilmelford	1919																																																																																																						
110	Kilmersdon	1919																																																																																																						
111	Kilmington	1919																																																																																																						
112	Kilmore	1919																																																																																																						
113	Kilmuckridge	1919																																																																																																						
PC	Z-whaler	14	<table border="1"> <tr><td>1</td><td>Zedwhale</td><td>1915</td></tr> <tr><td>2</td><td>Balena</td><td>1915</td></tr> <tr><td>3</td><td>Beluga</td><td>1915</td></tr> <tr><td>4</td><td>Bowhead</td><td>1915</td></tr> <tr><td>5</td><td>Bullwhale</td><td>1915</td></tr> <tr><td>6</td><td>Cachalot</td><td>1915</td></tr> <tr><td>7</td><td>Cowwhale</td><td>1915</td></tr> </table>	1	Zedwhale	1915	2	Balena	1915	3	Beluga	1915	4	Bowhead	1915	5	Bullwhale	1915	6	Cachalot	1915	7	Cowwhale	1915		346t, 40.5x7.6x2.6m, 2b,1vte, 1200hp, 13kts, 26p; 1x1-76/40(1), 1x1-76/50(2-14), 1x1-57/40(1)																																																																														
1	Zedwhale	1915																																																																																																						
2	Balena	1915																																																																																																						
3	Beluga	1915																																																																																																						
4	Bowhead	1915																																																																																																						
5	Bullwhale	1915																																																																																																						
6	Cachalot	1915																																																																																																						
7	Cowwhale	1915																																																																																																						

			8	Humpback	1915	
			9	Rorqual	1915	
			10	Rightwhale	1915	
			11	Icewhale	1915	
			12	Finwhale	1915	
			13	Pilotwhale	1915	
			14	Arctic Whale	1915	
ABS	-	5	1	Duke of Clarence	1891	1489brt; 95.2x11.0m, 2vte, 18.5kts; 1x1-102/40, 1x1-76/40
			2	Heroic	1906	2016brt, 97.6x12.6m, 2vqe, 18kts; 2x1-76/40
			3	Partridge II	1906	1523brt, 82.4x11.0m, 1vte, 16kts; 2x1-76/40
			4	Rowan	1909	1493brt, 85.6x11.6m, 1vte, 16kts; 2x1-76/40, 1x1-47/40
			5	Woodnut	1906	1523brt, 82.4x11.0m, 1vte, 14kts; 3x1-76/40
AFPV	-	4	1	Julia	1897	310t
			2	Argon	1904	380t
			3	Watchful	1911	612t
			4	Safeguard	1914	875brt
ASSV	-	1	1	Dargle	1902	253brt; 1x1-102/40, 2x1-76/40
APV	-	1	1	Duchess of York	1896	302brt
			1	Alacrity	1900	1792brt
			2	Surprise	1896	1143brt; 76.8x10.1m, 2vte, 17kts
			3	Triad	1908	1182brt, 76.3x10.7m, 2vte; 2x1-76/40
			4	Dotter	1887	165brt
			5	Helga	1908	323brt
			6	Ironsides		
			7	Catania	1895	589brt; 2x1-76/40
			8	Ceto	1888	140brt
			9	Clementina	1887	469brt
			10	Corycia	1896	195brt
			11	Diane	1902	194brt
			12	Eileen	1910	910brt; 2x1-76/40
			13	Ellida	1894	265brt
			14	Evening Star	1894	191brt
			15	Greta	1898	292brt; 1x1-76/40
			16	Hecate	1903	424brt; 1x1-76/40
			17	Hersilia	1895	330brt
			18	Ilex	1896	120brt
			19	James Fletcher	1907	264brt
			20	Kethailes	1903	625brt
			21	Lorna	1904	427brt

AY	-	43	22	Mera	1886		219brt
			23	Minona	1906		199brt
			24	Ombra	1902		236brt
			25	Oriana	1896		122brt
			26	Portia	1906		433brt
			27	Rhiannon	1914		126brt
			28	Rhouma	1902		279brt
			29	Sagitta	1908		744brt; 2x1-76/40
			30	Scadaun	1912		108brt
			31	Sea Fay	1902		164brt
			32	Shemara	1899		477brt; 1x1-76/40
			33	Sorceress	1887		222brt
			34	Taurus	1880		229brt
			35	Thistle	1881		369brt
			36	Vagrant	1903		440brt; 1x1-76/40
			37	Vanessa	1899		356brt
			38	Venetia	1905		577brt
			39	Verona	1890		331brt
			40	Wintonia	1894		168brt
			41	Zarefah	1905		235brt
42	Zaza	1905		423brt; 1x1-76/40			
43	Zoraide	1894		532brt; 1x1-76/40			

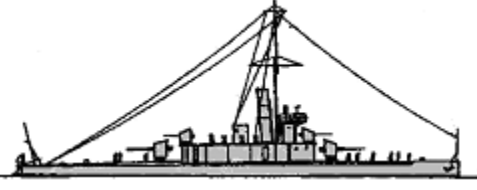

## OTHER FIGHTING SHIPS

PG	Ant	1	1	Arrow	1871		254t, 25.9x8.0x1.8-2.0m, 1b,2hse(t), 260hp, 8.5kts, 30p; 1x1-254MLR
	Medina	1	2	Tay	1876		363t, 33.5x10.4x1.8m, 1b,2hse, 310hp, 9.5kts, 51p; 3x1-160/16MLR
	Handy	1	3	Snapper	1883	No picture	508t, 35.1x11.3x2.8m, 2b,2hse, 310hp, 8.5kts; 1x1-190/45, 1x1-102/40
	Bramble	4	4	Bramble	1900		710t, 57.2x10.1x2.4m, 4b,2vte, 1300hp, 13.5kts, 85p; 2x1-102/40, 4x1-76/40, 10x1-11.4
			5	Britomart	1900		
			6	Dwarf	1899		
			7	Thistle	1901		
Heron	2	1, 2	Robin, Sandpiper	1898	No picture	85t, 32.8x6.1x0.6m, 1b,1vte, 240hp, 9kts, 25p; 2x1-57/40	
Woodcock	2	3	Woodcock	1898	No picture	150t, 44.2x7.3x0.6m, 1b,1vte, 550hp, 13kts, 25p; 2x1-57/40, 4x1-7.9	
		4	Woodlark	1898			
Teal	2	5	Teal	1901		180t, 48.7x7.5x0.8m, 1b,1vte, 670hp, 13kts, 35p; 2x1-57/40, 4x1-7.9	

PGR	Widgeon	1	6	Moorhen	1901			
			7	Widgeon	1904		195t, 48.7x7.5x1.0m, 1b,1vte, 800hp, 12.5kts, 35p; 2x1-57/40	
	Fly	16	8	Butterfly	1915		100t, 38.4x6.1x0.6m, 1b,1vte, 175hp, 9.5kts, 22p; 1x1-102/40, 1x1-76/40, 1x1-57/40 or 1x1-47/40 or 1x1-40/39	
			9	Dragonfly	1915			
			10	Firefly	1915			
			11	Crane-fly	1915			
			12	Mayfly	1915			
			13	Sawfly	1915			
			14	Gadfly	1915			
			15	Grayfly	1915			
			16	Snakefly	1915			
			17	Stonefly	1915			
			18	Waterfly	1915			
			19	Greenfly	1915			
			20	Blackfly	1916			
			21	Caddisfly	1916			
			22	Hoverfly	1916			
			23	Sedgefly	1916			
	Insect		12	24	Mantis	1915		750t, 72.4x11.0x1.2m, 2b,2vte, 2000hp, 14kts, 65p; 2x1-152/45(24-28,33), 1x1-152/45(29), 2x1-152/40(30-32,34,35), 2x1-76/45(30-32,34), 1x1-76/40(24,26-28,33), 2x1-76/40(25,29), 3x1-76/40(35), 1x1-40/39(24,26-28,33)
				25	Aphis	1915		
				26	Scarab	1915		
				27	Moth	1916		
				28	Gnat	1915		
				29	Bee	1916		
				30	Cicala	1916		
				31	Cockchafer	1916		
				32	Cricket	1916		
				33	Tarantula	1916		
				34	Glowworm	1916		
				35	Ladybird	1916		
	APGR	-	1	1	Kinsha	1900		616t; 2-76/40

### COASTAL FORCES

	CMB40	24	1 - 24	CMB3-7, 9, 12, 13, 43, 45, 46, 49, 51-61, 112		1916 - 1919		5t, 13.7x2.4x0.9m, 1pe, 250-275hp, 24.8-37.8kts, 2-3p; 1-450TT
PT	CMB55	61	25 -	CMB14A-17A, 19A, 20A, 21B-23B, 25BD, 26B, 27A-29A, 30B, 31BD, 32A, 34A-37A, 38B, 63BD, 64BD, 65A, 66BD, 68B, 69A, 70A, 72A, 73B-75B, 76A, 77A, 78E,		1917 -		11t, 18.3x3.4x0.9m, 2pe, 500-900hp,

			85	80C-82C, 83CE, 84C, 85C, 86BD, 87B, 88BD-92BD, 93E-97E, 98ED, 99ED, 113CK, 114D, 115DE, 116D, 117D	1919		35.1-41.2kts, 3-5p; (1-2)-450TT, 1dcr
	CMB70	3	86 - 88	CMB100M, 101M, 102MT	1919		24t, 22.1x4.3x1.1m, 2pe, 700-1400hp, 26-36.6kts, 3-5p; 1dcr, 7mines
YP	ML	~300	1- 300	~300 from ML1-17, 20-37, 39, 41-51, 53, 54, 56-61, 63, 65-96, 99-109, 111-113, 118-120, 122-126, 128-148, 150-190, 192-195, 198-228, 231-246, 248-252, 256-277, 279-355, 357-389, 391, 393, 395, 397-399, 401, 405-420, 422, 423, 425-430, 432, 433, 435-441, 443, 445, 447, 455, 457, 461, 463, 465-468, 473, 475-488, 490, 494-520, 522-533, 535-539, 542, 545, 546, 549-560, 562-565, 567-580	1915 - 1918		34-37t, 22.9-24.4x3.7x1.2m, 2pe, 440hp, 19kts, 8p; 1x1-76/23 or 1x1-47/40 or 1x1-47/46 or 1x1-40/37, 2dcr, sweeps

### AMPHIBIOUS SHIPS

			1	X1	1915		
			2	X2	1915		
			3	X6	1915		
			4	X7	1915		
			5	X8	1915		
			6	X12	1915		
			7	X13	1915		
			8	X14	1915		
			9	X15	1915		
			10	X16	1915		
			11	X17	1915		
			12	X19	1915		
			13	X20	1915		
			14	X21	1915		
			15	X22	1915		
			16	X23	1915		
			17	X24	1915		
			18	X26	1915		
			19	X28	1915		
			20	X29	1915		
			21	X31	1915		
			22	X33	1915		
			23	X34	1915		
			24	X35	1915		
			25	X36	1915		
			26	X37	1915		
			27	X38	1915		
			28	X39	1915		
			29	X40	1915		
			30	X43	1915		

31	X44	1915
32	X45	1915
33	X46	1915
34	X47	1915
35	X48	1915
36	X49	1915
37	X50	1915
38	X51	1915
39	X53	1915
40	X54	1915
41	X56	1915
42	X57	1915
43	X59	1915
44	X60	1915
45	X61	1915
46	X62	1915
47	X64	1915
48	X67	1915
49	X68	1915
50	X69	1915
51	X70	1915
52	X71	1915
53	X72	1915
54	X73	1915
55	X74	1915
56	X79	1915
57	X80	1915
58	X81	1915
59	X82	1915
60	X84	1915
61	X85	1915
62	X86	1915
63	X87	1915
64	X88	1915
65	X89	1915
66	X90	1915
67	X91	1915
68	X92	1915
69	X94	1915
70	X95	1915
71	X96	1915

X

138



160t, 32.3x6.4x1.1m, 1sd, 60hp, 8kts; 500troops

LC

72	X97	1915
73	X98	1915
74	X101	1915
75	X102	1915
76	X103	1915
77	X104	1915
78	X105	1915
79	X107	1915
80	X108	1915
81	X109	1915
82	X111	1915
83	X112	1915
84	X113	1915
85	X117	1915
86	X118	1915
87	X120	1915
88	X123	1915
89	X125	1915
90	X126	1915
91	X129	1915
92	X131	1915
93	X134	1915
94	X135	1915
95	X136	1915
96	X137	1915
98	X139	1915
99	X140	1915
100	X141	1915
102	X145	1915
103	X146	1915
104	X147	1915
105	X148	1915
106	X149	1915
107	X150	1915
108	X151	1915
109	X153	1915
110	X154	1915
111	X157	1915
112	X158	1915
113	X159	1915



114	X160	1915
115	X164	1915
116	X165	1915
117	X167	1915
118	X168	1915
119	X169	1915
120	X170	1915
121	X172	1915
122	X173	1915
123	X174	1915
124	X175	1915
125	X176	1915
126	X178	1915
127	X181	1915
128	X184	1915
129	X185	1915
130	X186	1915
131	X189	1915
132	X190	1915
133	X192	1915
134	X193	1915
135	X196	1915
136	X197	1915
137	X198	1915
138	X200	1915
139	X201	1916
140	X202	1916
141	X203	1916
142	X204	1916
143	X205	1916
144	X206	1916
145	X207	1916
146	X208	1916
147	X209	1916
148	X210	1916
149	X211	1916
150	X212	1916
151	X213	1916
152	X214	1916
153	X215	1916
154	X217	1916

X201

23





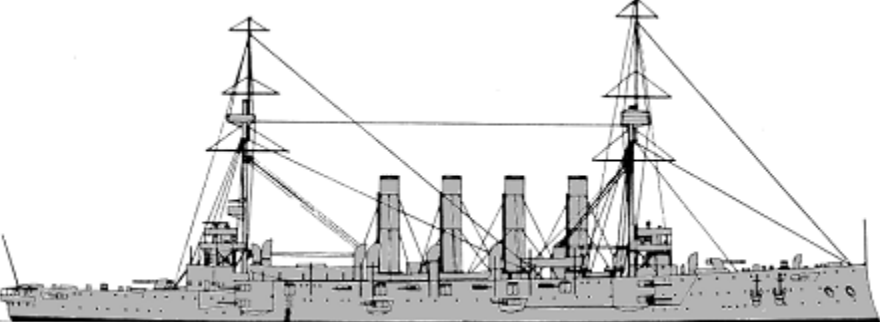

137t, 29.6x6.1x1.1m, 1sd, 60hp, 8kts; 500troops

			155	X218	1916		
			156	X219	1916		
			157	X221	1916		
			158	X222	1916		
			159	X223	1916		
			160	X224	1916		
			161	X225	1916		
DX	14		162	DX1	1916		137t, 29.6x6.1x1.1m, non-self-propelled; 500troops
			163	DX2	1916		
			164	DX3	1916		
			165	DX4	1916		
			166	DX5	1916		
			167	DX6	1916		
			168	DX7	1916		
			169	DX8	1916		
			170	DX9	1916		
			171	DX10	1916		
			172	DX11	1916		
			173	DX12	1916		
			174	DX13	1916		
				175	DX23		

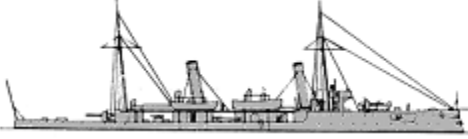
MINE WARFARE SHIPS

ML	M15	1	1	M22	1915		650t, 54.0x9.4x2.1m, 2b,2vte, 650hp, 9kts, 69p; 44mines
	Diadem	1	2	Amphitrite	1901		11000t, 141.0x21.0x7.8m, 30b,2vte, 18000hp, 20.7kts, 677p; Harvey: 102deck, 114casemates, 305CT; 4x1-152/40, 1x1-76/45, 354mines
AML	-	8	1	Biarritz	1914		2495brt, 104.0x12.8m, 2st, 23kts; 2x1-76/40, 180mines
			2	Princess Margaret	1914		5934brt, 120.5x16.5m, 2st, 15000hp, 23kts; 2x1-120/40, 2x1-76/40, 2x1-57/40, 500mines
			3	Wahine	1912		4436brt, 114.3x15.9m, 3st, 21kts; 2x1-76/50, 2x1-57/40, 180mines
			4	Russell II	1906		246brt; 24mines

		5	Shackleton	1913		288brt; 24mines
		6	St. Maurice	1902		251brt; 24mines
		7	Kate Lewis	1916		207brt; 24mines
		8	Strathcoe	1916		225brt; 24mines
Sharpshooter	4	1	Spanker	1890		735t, 70.1ppx8.2x3.2m, 4b,2vte, 3600hp, 19kts, 91p; 2x1-120/40, 4x1-47/40, 1-356TT, sweeps
		2	Speedwell	1890		
		3	Skipjack	1891		
		4	Gossamer	1891		
Alarm	2	5	Circe	1893		810t, 70.1ppx8.2x3.7m, 4b,3vte, 3500hp, 18.7kts, 91p; 2x1-120/40, 4x1-47/40, 1x5-11.4, 1-356TT, sweeps
		6	Leda	1893		
Dryad	3	7	Hamadryad	1894		1070t, 80.1x9.3x3.5m, 4b,2vte, 6000hp, 20kts, 120p; 2x1-120/40, 4x1-57/40, 1x5-11.4, (1+2x1)-450TT, sweeps
		8	Harrier	1895		
		9	Hussar	1895		
Ascot	19	10	Eridge	1916		810t, 74.9x17.7x2.1m, 2b,1dce(sw), 1500hp, 14.5kts, 50p; 2x1-57/40, 2x1-40/39, sweeps
		11	Chepstow	1916		
		12	Melton	1916		
		13	Atherstone	1916		
		14	Croxton	1916		
		15	Gatwick	1916		
		16	Lingfield	1916		
		17	Pontefract	1916		
		18	Epsom	1916		
		19	Chelmsford	1916		
		20	Doncaster	1916		
		21	Newbury	1916		
		22	Eglinton	1916		
		23	Haldon	1916		
		24	Cheltenham	1916		
		25	Hurst	1916		
26	Goodwood	1916				
27	Totnes	1916				
28	Sandown	1916				
		29	Belvoir	1917		
		30	Bicester	1917		
		31	Cattistock	1917		
		32	Cotswold	1917		
		33	Cottesmore	1917		
		34	Croome	1917		

MS	Hunt	19	35	Dartmoor	1917		870t, 70.4x8.5x2.1m, 2b,2vte, 1800hp, 16kts, 71p; (1-2)x1-76/40, (1-2)x1-57/40, sweeps
			36	Garth	1917		
			37	Hambledon	1917		
			38	Heythrop	1917		
			39	Holderness	1917		
			40	Meynell	1917		
			41	Muskerry	1917		
			42	Oakley	1917		
			43	Pytchley	1917		
			44	Quorn	1917		
			45	Southdown	1917		
			46	Tedworth	1917		
			47	Zetland	1917		
Dance	12	48	Coverley	1917		265-290t, 39.6x8.0x1.1m, 1b,2vte, 450hp, 9.5kts, 22-26p; 1x1-76/40(55,56), 1x1-57/40(49,51,53,55,56,58,59), 1x1-47/40(48,50,52,54,57), sweep	
		49	Hornpipe	1917			
		50	Cotillion	1917			
		51	Minuet	1917			
		52	Quadrille	1917			
		53	Mazurka	1917			
		54	Pirouette	1917			
		55	Tarantella	1917			
		56	Gavotte	1918			
		57	Sarabande	1918			
		58	Morris Dance	1919			
		59	Step Dance	1919			
Banbury	7	60	Hexham	1918		820t, 76.1x17.7x2.1m, 2b,1dc(sw), 1500hp, 14.5kts, 52p; 2x1-57/40, 2x1-40/39, sweeps	
		61	Lanark	1918			
		62	Banbury	1918			
		63	Shincliffe	1918			
		64	Harpenden	1918			
		65	Wetherby	1918			
		66	Lewes	1918			
		67	Gaddesdon	1918			
		68	Irvine	1918			
		69	Kendal	1918			
		70	Gainsborough	1918			
		71	Shrewsbury	1918			
		72	Burslem	1918			
		73	Badminton	1918			
		74	Sligo	1918			
		75	Pangbourne	1918			

76	Gretna	1918
77	Aberdare	1918
78	Sutton	1918
79	Clonmel	1918
80	Banchory	1918
81	Bagshot	1918
82	Craigie	1918
83	Fareham	1918
84	Abingdon	1918
85	Bootle	1918
86	Munlochy	1918
87	Newark	1918
88	Northolt	1918
89	Pontypool	1918
90	Sherborne	1918
91	Widnes	1918
92	Stoke	1918
93	Faversham	1918
94	Saltash	1918
95	Harrow	1918
96	Marlow	1918
97	Nailsea	1918
98	Derby	1918
99	Blackburn	1918
100	Tring	1918
101	Leamington	1918
102	Yeovil	1918
103	Rugby	1918
104	Stafford	1919
105	Tiverton	1918
106	Saltburn	1919
107	Mallaig	1918
108	Ford	1918
109	Mistley	1918
110	Tonbridge	1918
111	Prestatyn	1918
112	Forfar	1919
113	Albury	1919
114	Forres	1919
115	Selkirk	1919

Aberdare

82



930t, 70.4x8.7x2.3m, 2b,2vte, 2200hp, 16kts, 74p; 1x1-102/44, 1x1-76/40, sweeps

116	Lydd	1919
117	Caerleon	1919
118	Tralee	1919
119	Swindon	1919
120	Camberley	1919
121	Alresford	1919
122	Huntley	1919
123	Dundalk	1919
124	Fermoy	1919
125	Malvern	1919
126	Weybourne	1919
127	Elgin	1919
128	Petersfield	1919
129	Caterham	1919
130	Longford	1919
131	Barnstaple	1919
132	Dunoon	1919
133	Havant	1919
134	Salford	1919
135	Instow	1919
136	Marazion	1919
137	Truro	1919
138	Carstairs	1919
139	Bradfield	1919
140	Bury	1919
141	Fairfield	1919
142	Monaghan	1919
143	Repton	1919
144	Ross	1919
145	Cheam	1919
146	Appledore	1919
147	Wem	1919
148	Wexford	1919

Military	7	1	Drummer	1915
		2	Gunner	1915
		3	Carbinier II	1915
		4	Bombardier	1915
		5	Brigadier	1915
		6	Highlander	1915
		7	Trooper	1915

No picture

239-303t, 36.0-39.6(pp)x6.9-7.3x3.7-4.0m, 1b,1vte; 1x1-76/40(1,3,4,5) or 1x1-47/40 or 1x1-57/40, (0-1)dct, sweeps

	William	
--	---------	--

8	Westenburgh	1917
9	John Appleby	1917
10	John Arthur	1917
11	Anthony Aslett	1917
12	Cornelius Buckley	1917
13	William Abrahams	1917
14	John Quilliam	1917
15	George Bligh	1917
16	John Yule	1917
17	Andrew King	1917
18	John Pasco	1917
19	Edward Williams	1917
20	Thomas Atkinson	1917
21	William Dogherty	1917
22	Alexander Hills	1917
23	Charles Adair	1917
24	William Ram	1917
25	William Rivers	1917
26	Lewes Reeves	1917
27	James Adams	1917
28	Lewes Roatley	1917
29	George Andrew	1917
30	Robert Bookless	1917
31	Thomas Bailey	1917
32	Robert Barton	1917
33	Christopher Dixon	1918
34	John Cormack	1917
35	James Buchanan	1917
36	Samuel Dowden	1917
37	Fraser Eaves	1917

Mersey

71

38	John Ebbs	1917
39	Boadicea II	1918
40	John Felton	1918
41	Daniel Fearall	1918
42	George Fenwick	1918
43	George Westphall	1918
44	John Welstead	1918
45	Henry Cramwell	1918
46	Henry Lancaster	1919
47	Isaac Chant	1918
48	James Jones	1918
49	James Ludford	1919
50	James Wright	1918
51	John Edmund	1918
52	John Jacobs	1918
53	John Jefferson	1918
54	John Johnson	1918
55	Richard Colliver	1918
56	Robert Double	1918
57	Samuel Jameson	1918
58	Thomas Jarvis	1918
59	Thomas Johns	1918
60	Thomas Thresher	1918
61	Thomas Whipple	1918
62	William Doak	1918
63	William Inwood	1918
64	William Jackson	1918
65	William Jones	1918
66	Jeremiah Lewes	1918



665t, 45.1x7.2x2.8m, 1b,1vte, 600hp, 11kts; 1x1-102/40(37,72), 2x1-76/40(8), 1x1-76/40(9-36,38-73,75-78), 1x1-57/40(74), sweep



67	John Dutton	1918
68	Nicholas Dean	1918
69	John Dunn	1918
70	Robert Drummond	1918
71	Edward Druce	1918
72	Thomas Jago	1918
73	Andrew Jewer	1918
74	Richard Jewell	1918
75	James Caton	1918
76	William Honor	1918
77	John Highland	1918
78	Excellent	1919
79	Pekin	1917
80	John Gillman	1917
81	Daniel Henley	1917
82	James Hunniford	1917
83	Daniel Harrington	1917
84	Thomas Deas	1917
85	John Kidd	1917
86	Arthur Lessimore	1917
87	Peter Lovett	1917
88	John Lyons	1917
89	William Mannell	1917
90	John Burlingham	1917
91	Robert Betson	1917
92	Michael Maloney	1917
93	Hugh Black	1917
94	James Berry	1917
95	Alexander Palmer	1917
96	John Pollard	1917
97	Oliver Pickin	1917
98	James Robertson	1917

99	Richard Roberts	1917
100	John Brooker	1917
101	Richard Bagley	1917
102	Thomas Crofton	1917
103	Charles Chappel	1917
104	William Spencer	1917
105	Andrew Sack	1917
106	John Cooper	1917
107	Neil Smith	1917
108	John Bullock	1917
109	James Connor	1917
110	John Thorling	1917
111	Thomas Twiney	1917
112	William Beeton	1917
113	William Cowling	1917
114	William Coburne	1917
115	Alexander Scott	1917
116	William Chaseman	1917
117	John Brice	1918
118	James Burgess	1917
119	Thomas Robins	1917
120	Walter Burke	1917
121	John Brennan	1918
122	James Chapman	1917
123	Samuel Spencer	1917
124	William Beatty	1917
125	William Carrick	1917
126	William Cale	1917
127	George	1918

	Aunger	
128	Charles Doran	1917
129	Benjamin Cooke	1917
130	Valentine Bower	1917
131	William Symons	1917
132	William Wilmot	1917
133	James Green	1917
134	John Casewell	1917
135	William Bunce	1917
136	Timothy Crawley	1917
137	John Church	1917
138	James Peake	1917
139	Matthew Flynn	1918
140	Thomas Goble	1917
141	Peter Blumberry	1918
142	William Browis	1918
143	George Dixon	1917
144	Joseph Barratt	1918
145	Richard Bacon	1918
146	William Downes	1917
147	Thomas Dowding	1917
148	Phineas Beard	1918
149	William Cummins	1917
150	Thomas Connolly	1918
151	Robert Davidson	1918
152	Thomas Chambers	1917
153	Denis Casey	1918

TL	Castle	184	154	John Chivers	1917
			155	Joseph Button	1918
			156	William Brady	1918
			157	Robert Cloughton	1917
			158	Joseph Connell	1918
			159	James Christopher	1918
			160	Patrick Bowe	1918
			161	William Bell	1918
			162	William Flemming	1918
			163	Charles Boyes	1918
			164	Thomas Booth	1918
			165	James Cepell	1918
			166	Morgan Jones	1918
			167	Henry Chevallier	1918
			168	Dominick Dubine	1918
			169	Frederick Bush	1918
			170	Robert Bowen	1918
			171	William Carr	1918
			172	Edward Collingwood	1918
			173	John Cattling	1918
			174	Emmanuel Camelaire	1918
			175	John Baptish	1918
			176	John Bateman	1918
			177	Arthur Cavanagh	1918
178	James Dinton	1918			
179	Thomas Hankins	1918			
180	Michael Ging	1918			
181	John Bomkworth	1918			
182	Thomas Bartlett	1918			
183	Idaho	1918			



547t, 40.8x7.2x2.8m, 1b,1vte, 480hp, 10.5kts; 1x1-102/40(183), 1x1-76/40(79-181,184-194,196-262), 1x1-57/40(182,195), (0-1)dct, sweeps

184	Richard Crofts	1918
185	Charles Donnelly	1918
186	Joseph Gordon	1918
187	Isaac Heath	1918
188	Thomas Daniels	1918
189	William Leek	1918
190	Domque Gentile	1918
191	John Gauntlet	1919
192	Griffith Griffith	1919
193	Michael Griffith	1919
194	George Greenfield	1918
195	George Harris	1918
196	George Darby	1918
197	John Davis	1918
198	William Humphries	1918
199	John Geoghan	1918
200	Joseph Giddice	1918
201	William Hannam	1919
202	Samuel Drake	1918
203	Peter Hall	1918
204	Charles Legg	1919
205	George Corten	1919
206	James Lay	1918
207	TR1	1917
208	TR2	1917
209	TR3	1918
210	TR4	1918
211	TR6	1918
212	TR7	1918
213	TR8	1918
214	TR9	1918
215	TR10	1918

216	TR11	1918
217	TR12	1918
218	TR13	1918
219	TR14	1918
220	TR15	1918
221	TR16	1918
222	TR17	1918
223	TR18	1918
224	TR19	1918
225	TR20	1918
226	TR21	1918
227	TR22	1918
228	TR23	1918
229	TR24	1917
230	TR25	1918
231	TR26	1918
232	TR27	1918
233	TR28	1918
234	TR29	1918
235	TR30	1918
236	TR31	1918
237	TR32	1918
238	TR33	1918
239	TR34	1918
240	TR35	1918
241	TR36	1918
242	TR39	1918
243	TR40	1918
244	TR41	1919
245	TR42	1919
246	TR43	1919
247	TR46	1919
248	TR50	1919
249	TR53	1918
250	TR54	1918
251	TR55	1918
252	TR56	1918
253	TR57	1919
254	TR58	1918
255	TR59	1918
256	Bombay	1919

257	Calcutta	1919
258	Colombo	1919
259	Kennery	1919
260	Kidderpore	1919
261	Salsette	1919
262	Sealdah	1919
263	James Aldridge	1917
264	James Archibald	1917
265	John Bradford	1917
266	William Barlow	1917
267	Richard Bennett	1917
268	Thomas Ansell	1917
269	Samuel Baker	1917
270	Israel Aldcroft	1917
271	George Borthwick	1917
272	James Bentole	1917
273	John Barry	1917
274	John Abbott	1917
275	Thomas Bryan	1917
276	William Biggs	1917
277	John Brasket	1917
278	Samuel Barkas	1917
279	Joseph Annison	1917
280	Matthew Crooke	1917
281	John Callaghan	1917
281	William Butler	1917
282	William Castle	1917
283	James Beagan	1917
284	Benjamin Coleman	1917
285	John Clay	1918

286	Peter Dobbin	1918
287	James Curry	1917
288	George Burton	1917
289	John Fitzgerald	1918
290	James Evans	1918
291	John Dupuis	1918
292	John Haile	1918
293	Joseph Coates	1918
294	William Ferrins	1918
295	William Hutchinson	1918
296	William Cogswell	1918
297	Cornelius Carroll	1918
298	John Bell	1918
299	John Bowler	1918
300	Joseph Burgin	1918
301	Robert Gibson	1918
302	Thomas Dear	1918
303	John Gray	1918
304	George Coulston	1918
305	William Barrow	1918
306	Barnard Boyle	1918
307	David Blake	1918
308	John Kentall	1918
309	Samuel Benbow	1918
310	William Beaumont	1918
311	Henry Harding	1918
312	William Griffin	1918
313	William Hanbury	1918
314	John Dunkin	1918
315	Robert Harding	1919
316	Thomas	1918

Strath

82

No picture

429t, 37.5x6.8x2.8m, 1b,1vte, 430hp, 10kts; 1x1-76/40(263-332,333-344), 1x1-57/40(333), (0-1)dct, sweeps



	Burnham	
317	John Buller	1918
318	Thomas Haggerty	1918
319	Richard Briscoll	1918
320	Thomas Barclay	1918
321	William King	1918
322	James Hartwell	1918
323	Edward Barker	1918
324	James Brodigan	1918
325	George French	1918
326	George Ireland	1919
327	Henry Flight	1918
328	Henry Jennings	1919
329	James Fennell	1918
330	John Curran	1918
331	John Fairman	1918
332	John Fisser	1918
333	John Francois	1918
334	John Hunter	1919
335	John Jackson	1918
336	Jonathan Hardy	1918
337	Richard Heaver	1918
338	Robert Farecloth	1919
339	Thomas Evison	1918
340	William Fall	1918
341	William Gibbons	1918
342	William Hallett	1919
343	William Ivey	1918
344	Henry Battersby	1919

Axe	5	345	Battleaxe	1916		520(345-347,349)-540(348)t, 42.3(345-347,349)-43.0(348)x7.2x3.7(345-347,349)-3.8(348)m, 1b,1vte, 490(345-347,349)-500(348)hp, 10.5(345-347,349)-11(348)kts, 20p; 1x1-76/40(348), 1x1-75/48(345-347,349), sweeps
		346	Goldaxe	1916		
		347	Iceaxe	1916		
		348	Poleaxe	1917		
		349	Stoneaxe	1916		
Admiralty steel	66	1	Billow	1918		200t, 28.4x5.7x2.3m, 1b,1vte, 270hp, 9kts; 1x1-57/40 or 1x1-57/42, sweep
		2	Blizzard	1918		
		3	Brine	1918		
		4	Calm	1918		
		5	Cascade	1918		
		6	Clearing	1919		
		7	Cloud	1918		
		8	Cold Snap	1918		
		9	Coldblast	1919		
		10	Conflagration	1919		
		11	Crescent Moon	1918		
		12	Current	1919		
		13	Daybreak	1918		
		14	Dayspring	1917		
		15	Dew	1918		
		16	Dusk	1918		
		17	Eddy	1918		
		18	Attentive	1918		
		19	Flash	1918		
		20	Flicker	1918		
		21	Fork Lightning	1918		
		22	Freshet	1918		
		23	Froth	1918		
		24	Fumarole	1919		
		25	Fume	1919		
		26	Glitter	1918		
		27	Grey Sea	1919		
		28	Gulf Stream	1919		
		29	Gust	1918		
		30	Halo	1918		
		31	Harmattan	1918		
		32	Horizon	1918		
		33	Icepack	1918		
		34	Iceicle	1918		
		35	Indian	1918		

	Summer	
36	Landfall	1918
37	Leeward	1918
38	Leeway	1918
39	Levanter	1918
40	Low Tide	1919
41	Lull	1918
42	Lunar Bow	1918
43	Mirage	1918
44	Mist	1918
45	Moonbeam	1918
46	Moonshine	1918
47	Murk	1918
48	Nebula	1918
49	Node	1918
50	Noontide	1918
51	Overfall	1918
52	Quicksand	1919
53	Sandstorm	1918
54	Seabreeze	1919
55	Sheen	1918
56	Shower	1918
57	Sleet	1918
58	Snowdrift	1918
59	Snowflake	1919
60	Spectrum	1918
61	Sunburst	1918
62	Sundown	1919
63	Sunset	1918
64	Undertow	1919
65	Waft	1919
66	White Horses	1919
67	Afterglow	1918
68	Ambitious	1918
69	Anticyclone	1918
70	Astral	1918
71	Atmosphere	1918
72	Avalanche	1918
73	Backwash	1918
74	Black Frost	1918
75	Black Night	1918

DF

Admiralty  
wooden

57

76	Blue Sky	1918
77	Borealis	1918
78	Cirrus	1918
79	Cumulus	1918
80	Daylight	1918
81	Etesian	1918
82	Fair Weather	1918
83	Fiery Cross	1918
84	Firelight	1919
85	Firmament	1918
86	Flame	1918
87	Flat Calm	1918
88	Fogbow	1918
89	Full Moon	1918
90	Gleam	1919
91	Gloaming	1919
92	Hailstorm	1918
93	Heat Wave	1918
94	Imbat	1918
95	Iridescence	1917
96	Mackerel Sky	1919
97	Midnight Sun	1918
98	Nadir	1918
99	Nightfall	1918
100	Nimbus	1918
101	Packice	1918
102	Rainstorm	1918
103	Ray	1918
104	Red Sky	1918
105	Rising Sea	1918
106	Runnel	1918
107	Scend	1919
108	Scour	1919
109	Scud	1919
110	Shadow	1918
111	Sheet Lightning	1918
112	Shimmer	1919
113	Shooting Star	1918
114	Silhouette	1918
115	Silt	1919



175t, 28.7x6.1x2.2m, 1b,1vte, 270hp, 9kts; 1x1-57/40 or 1x1-57/42, sweeps

			116	Solstice	1918		
			117	Squall	1918		
			118	Starlight	1919		
			119	Stormcentre	1918		
			120	Stormwrack	1918		
			121	Sunlight	1919		
			122	Swirl	1919		
			123	Tropic	1919		
AMS -	17		1	Reindeer	1897		1281brt, 85.3x10.5m, 2vte, 20kts; 2x1-76/40, sweeps
			2	Folkestone	1903		496brt; 2x1-76/40, sweeps
			3	Gazelle	1889		613brt; 2x1-76/40, sweeps
			4	Lynn	1889		609brt; 2x1-76/40, sweeps
			5	Newmarket	1907		833brt; 2x1-76/40, sweeps
			6	Aiglon	1898		647brt
			7	Bourne	1908		353brt
			8	Duchess of Rothesay	1895		385brt; 1x1-76/40
			9	Eagle III	1910		432brt
			10	Isle of Arran	1892		313brt
			11	Jupiter II	1896		394brt
			12	Kylemore	1897		319brt
			13	Marmion II	1906		403brt
			14	Mercury	1892		378brt
			15	Verdun II	1888		804brt
			16	Waverley	1899		449brt
			17	Yarmouth Belle	1898		522brt
			1	Nairn	1910		207brt
			2	Rose	1907		243brt
			3	Seaflower	1908		275brt; 1x1-76/40, sweeps
			4	Seamew	1908		265brt; 1x1-76/40, sweeps
			5	Sparrow	1908		266brt; 1x1-76/40, sweeps
			6	Janus	1911		243brt; 1x1-76/40, sweeps
			7	Osborne Stroud	1912		209brt
			8	Kumarihami	1913		259brt
			9	Lakshmi	1913		249brt
			10	Lankdys	1911		255brt
			11	Parvati	1912		208brt
			12	Ranmenika	1913		224brt
			13	Sarasvati II	1911		204brt

14	Cabalsin	1904		218brt
15	Cachosin	1912		213brt; 1x1-76/40
16	Caersin	1892		133brt
17	Callsin	1896		136brt
18	Calumsin	1902		224brt
19	Cambrsin	1891		158brt
20	Campsin	1894		133brt
21	Canossin	1894		153brt
22	Carbosin	1896		158brt
23	Censin	1894		145brt
24	Checksin	1895		140brt
25	Chirsin	1912		218brt
26	Churchsin	1900		142brt
27	Clarosin	1897		159brt
28	Classin	1889		182brt
29	Clearsin	1891		155brt
30	Clonsin	1911		202brt
31	Coalsin	1892		130brt
32	Cooksin	1896		149brt
33	Coomasin	1897		170brt
34	Corinsin	1896		159brt
35	Cradosin	1895		133brt
36	Craigsin	1895		141brt
37	Cromsin	1895		138brt
38	Cudwosin	1907		112brt
39	Culbasin	1893		133brt
40	Boneaxe			
41	Bronzeaxe			
42	Coalaxe	1910		263brt
43	Dreadaxe			
44	Firmaxe	1908		270brt
45	Greataxe	1899		187brt
46	Silveraxe	1908		272brt; 1x1-76/40
47	Sureaxe	1907		195brt
48	Agatha II	1896		137brt
49	Agnes Nutten	1915		183brt
50	Alpha	1900		274brt; 1x1-76/40
51	Amplify	1916		342brt
52	Anson II	1905		211brt
53	Aurea	1917		270brt; 1x1-76/40
54	Ben Barvas	1914		198brt

55	Ben Doran	1900		155brt
56	Ben Dearg	1901		183brt
57	Bermuda	1905		211brt
58	Bush	1908		221brt; 1x1-76/40
59	Cambodia	1911		284brt
60	Cardinal	1912		309brt; 1x1-76/40
61	City of York	1904		202brt; 1x1-76/40
62	Coot	1906		172brt; 2x1-76/40
63	Corythaix	1910		280brt
64	Courser	1905		227brt
65	Craigmillar	1896		112brt
66	Daimler	1910		257brt
67	Daneston	1915		239brt
68	Darogah	1914		221brt
69	Dentaria	1908		259brt; 1x1-76/40
70	Diana	1899		172brt; 2x1-76/40
71	Dogger Bank	1913		274brt
72	Earl Essex	1914		225brt; 1x1-76/40
73	Earl Kitchener	1915		348brt; 1x1-76/40
74	Ebro II	1898		175brt
75	Echo	1897		165brt
76	Elm	1899		168brt; 1x1-76/40
77	Empyrean	1914		215brt
78	Erna	1915		330brt
79	Eroican	1914		225brt
80	Escort	1897		165brt
81	Eske	1906		290brt
82	Eton	1897		165brt
83	Eureka	1897		165brt
84	Fair Isle II	1909		192brt
85	Filey	1914		226brt; 1x1-76/40
86	Flintshire	1916		215brt
87	Gaul	1905		270brt; 1x1-76/40
88	General Gordon	1905		267brt
89	Gertrude Cappleman	1915		195brt
90	Good Hope	1903		256brt; 1x1-76/40
91	Gowan	1905		173brt; 1x1-76/40
92	Hero	1907		226brt
93	Hornsea	1900		305brt

ATL -

171

94	Isernia	1899		198brt
95	Jacinta	1915		239brt
96	Janus II	1905		240brt
97	Jericho	1914		351brt; 1x1-76/40
98	Joseph & Sarah Miles	1902		272brt; 1x1-76/40
99	Kincorth	1909		148brt
100	King Arthur	1899		159brt
101	King Egbert	1899		159brt
102	King Richard	1900		162brt
103	Ladysmith	1906		254brt; 1x1-76/40
104	Leonora	1904		217brt
105	Lizzie	1907		278brt; 1x1-76/40
106	Loch Esk	1908		215brt
107	Lombard	1909		272brt; 1x1-76/40
108	Lord Percy	1911		215brt
109	Louise	1907		270brt
110	Manorbier Castle	1898		153brt
111	Margaret Wetherly	1911		211brt
112	Martineta	1909		279brt
113	Mena	1914		234brt
114	Merlin	1899		186brt
115	Meror	1905		250brt
116	Minoru II	1909		260brt
117	Neil Gow	1911		255brt; 1x1-76/40
118	Hokianga	1898		290brt
119	Nylghau	1908		261brt; 1x1-76/40
120	Ocean Prince	1902		203brt
121	Osta	1915		230brt
122	Ostrich II	1903		244brt
123	Passing	1913		459brt; 1x1-76/40
124	Pegas	1917		219brt; 1x1-76/40
125	Pelican II	1905		205brt; 1x1-76/40
126	Perihelion	1914		215brt
127	Pretoria	1902		180brt
128	Quest	1900		161brt
129	Rambler	1898		162brt
130	Recono	1916		248brt
131	Recordo	1910		230brt



132	Reindeer II	1902		192brt
133	Relonzo	1914		245brt; 1x1-76/40
134	Remexo	1912		231brt; 1x1-102/40
135	Remo	1900		169brt
136	Resmilo	1917		258brt; 1x1-76/40
137	Resolvo	1913		231brt
138	Retrudo	1913		178brt
139	Rinaldo II	1900		166brt
140	Rodino	1913		230brt; 1x1-76/40
141	Rodosto	1913		174brt; 1x1-76/40
142	Ronso	1915		248brt
143	Roto	1904		170brt
144	Roxano	1907		228brt
145	Russell II	1906		246brt
146	St. Denis	1915		294brt; 1x1-76/40
147	St. Maurice	1903		251brt
148	Samurai	1914		221brt
149	Semnos	1914		216brt
150	Shackleton	1913		288brt
151	Snipe	1897		166brt
152	Soldier Prince	1900		156brt
153	Star of Britain	1908		228brt
155	Staunton	1908		283brt
156	Stewart Boyle	1911		197brt
157	Strathcoe	1916		215brt
158	Stratherrick	1906		201brt
159	Strathlee	1917		215brt
160	Strathmaree	1914		210brt
161	Thrush II	1902		166brt
162	Touraco	1903		245brt
163	Tribune II	1913		293brt
164	Unicorn	1895		134brt
165	Vambery	1917		316brt
166	Veresis	1915		302brt
167	Victoria II	1912		221brt
168	Victorian II	1900		195brt
169	Viola II	1905		228brt; 1x1-76/40
170	Volesus	1913		293brt
171	Welbeck	1915		302brt
1	Capella	1892		111brt
2	Chestnut	1914		107brt

ADF -	10	3	Excel	1907		103brt
		4	Nulli Secundus	1917		104brt
		5	Ploughboy	1912		102brt
		6	Primevere	1914		100brt
		7	Queen Mother	1915		126brt
		8	Realize	1914		103brt
		9	Sedulous	1912		100brt
		10	Young Sid	1912		100brt; 1x1-76/40



© Ivan Gogin, 2014

[home](#)[World navies yesterday](#)[1920](#)

# United States of America 01 January 1920

## CAPITAL SHIPS

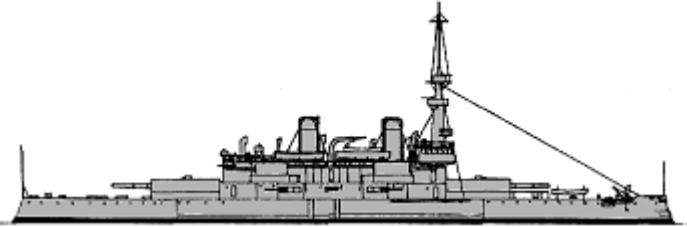
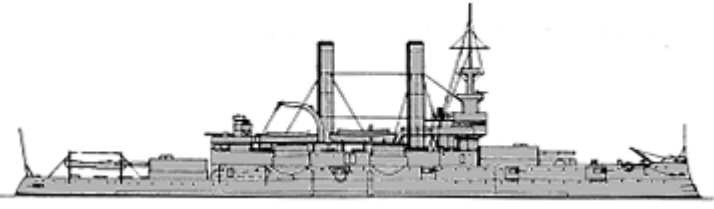
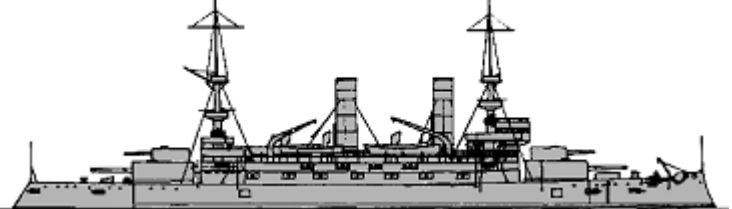
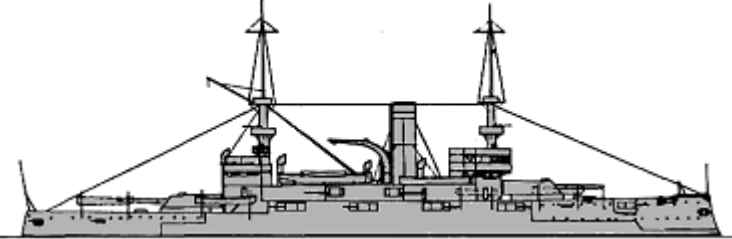
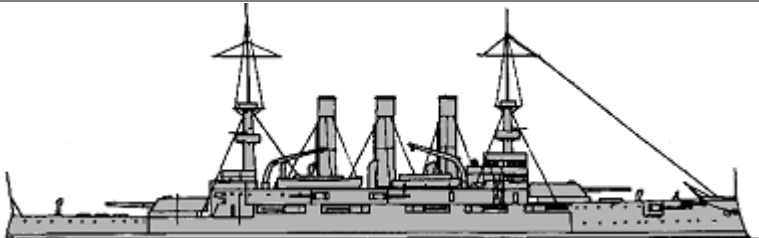
Indiana	1	BB1	Indiana	1895		11688t, 107.0x21.1x7/3m, 8b,2vte, 9000hp, 15kts, 473p; Harvey: 457belt, 76deck, 432turrets, 254CT; 2x2-330/35, 4x2-203/37, 4x1-76/50, 10x1-57/40	
	2	BB2	Massachusetts	1896			
	3	BB3	Oregon	1896			
Iowa	1	4	BB4	Iowa	1897		12647t, 110.5x22.0x7.3m, 5b,2vte, 11000hp, 16kts, 486p; Harvey: 356belt, 76deck, 381turrets, 254CT; 2x2-305/35, 4x2-203/37, 10x1-102/40
Kearsarge	5	BB5	Kearsarge	1900		12850t, 114.4x22.0x7.2m, 5b,2vte, 10000hp, 16kts, 553p; Harvey: 419belt, 127deck, 432turrets, 254CT; 2x2-330/35, 2x2-203/37, 8x1-127/40, 2x1-76/50	
	6	BB6	Kentucky	1900			
Illinois	7	BB7	Illinois	1901		12250t, 114.4(7)-114.0(8,9)x22.0x7.2m, 8b,2vte, 10000hp, 16kts, 536p; Harvey: 419belt, 127deck, 356turrets, 254CT; 2x2-330/35, 8x1-152/40, 6x1-76/50, 4x1-57/40, 6x1-37/40(7,9), 4x1-37/40(8)	
	8	BB8	Alabama	1900			
	9	BB9	Wisconsin	1901			
Maine	10	BB10	Maine	1902		13700t, 120.1x22.0x7.2-7.4m, 12b,2vte, 16000hp, 18kts, 561p; 279belt, 102deck, 305turrets, 254CT; 2x2-305/40, 8x1-152/49, 8x1-76/50, 8x1-47/40, 6x1-37/40, 2-450TT	
	11	BB11	Missouri	1903			
	12	BB12	Ohio	1904			
	13	BB13	Virginia	1906			

BB	Virginia	5	14	BB14	Nebraska	1907		<p>16094t, 134.5x23.3x7.2m, 12b,2vte, 19000hp, 19kts, 812p; 279belt, 76deck, 305turrets, 229CT; 2x2-305/40, 4x2-203/45, (6-8)x1-76/50, 4-533TT</p>
			15	BB15	Georgia	1906		
			16	BB16	New Jersey	1906		
			17	BB17	Rhode Island	1906		
			18	BB18	Connecticut	1906		
	Connecticut	2	19	BB19	Louisiana	1906		<p>17666t, 139.1x23.4x7.5m, 12b,2vte, 16500hp, 18kts, 827-896p; 279belt, 76deck, 279turrets, 229CT; 2x2-305/45, 4x2-203/45, 14x1-76/50, 4x1-37/40(18), 2x1-37/40(19), 4-533TT</p>
			20	BB20	Vermont	1907		
	Vermont	4	21	BB21	Kansas	1907		<p>17666t, 139.1x23.4x7.5m, 12b,2vte, 16500hp, 18kts, 850-880p; 229belt, 76deck, 305turrets, 229CT; 2x2-305/45, 4x2-203/45, 14x1-76/50, 2x1-37/40, 4-533TT</p>
			22	BB22	Minnesota	1907		
			23	BB25	New Hampshire	1908		
24	BB26		South Carolina	1910				
South Carolina	2	25	BB27	Michigan	1910		<p>17617t, 138.0x24.5x7.5m, 12b,2vte, 16500hp, 18.5kts, 869p; 305belt, 64deck, 305turrets, 305CT; 4x2-305/45, 14x1-76/50, 2-533TT</p>	
		26	BB28	Delaware	1910			
Delaware	2	27	BB29	North Dakota	1910		<p>22060t, 158.2x26.0x8.3m, 14b,2vte(26)-14b,2gt(27), 25000hp, 21kts, 933p; 279belt, 51deck, 305turrets, 292CT; 5x2-305/45, 14x1-127/50, 8x1-76/50, 2-533TT</p>	
		28	BB30	Florida	1911			
Florida	2	29	BB31	Utah	1911		<p>23033t, 159.0x26.9x8.6m, 12b,4st, 28000hp, 20.8kts, 1001p; 279belt, 38deck, 305turrets, 292CT; 5x2-305/45, 16x1-127/51, 8x1-76/50, 2-533TT</p>	
		30	BB32	Wyoming	1912			

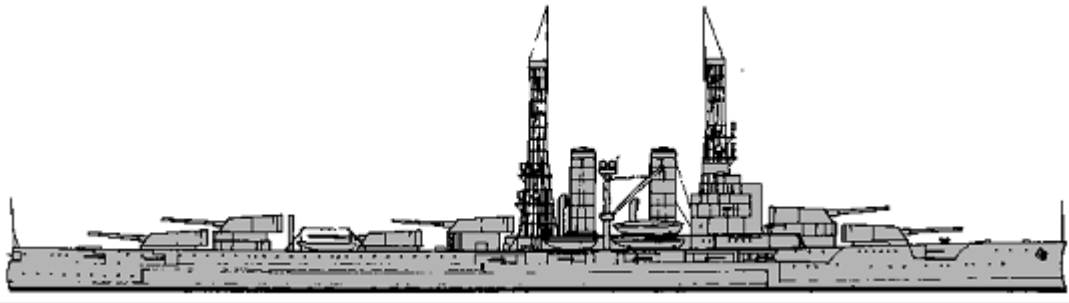
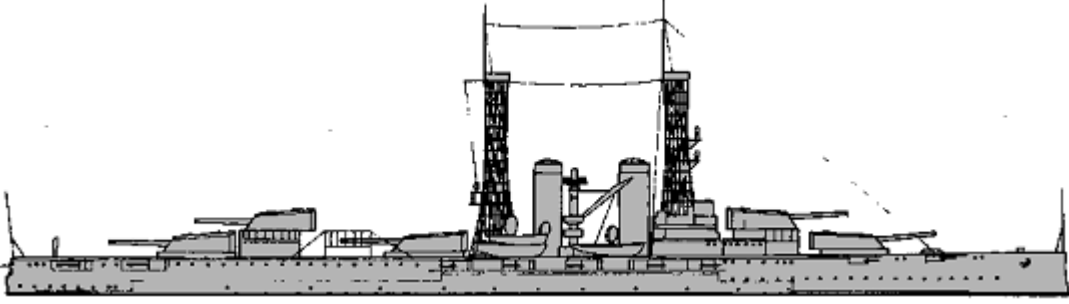
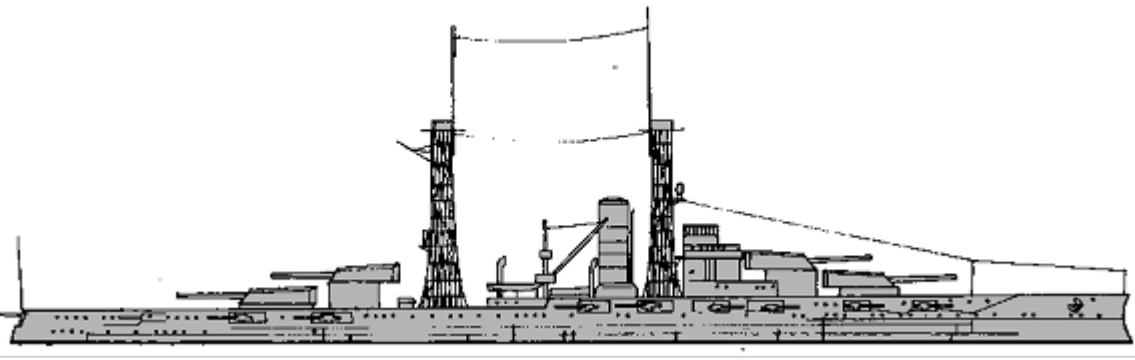
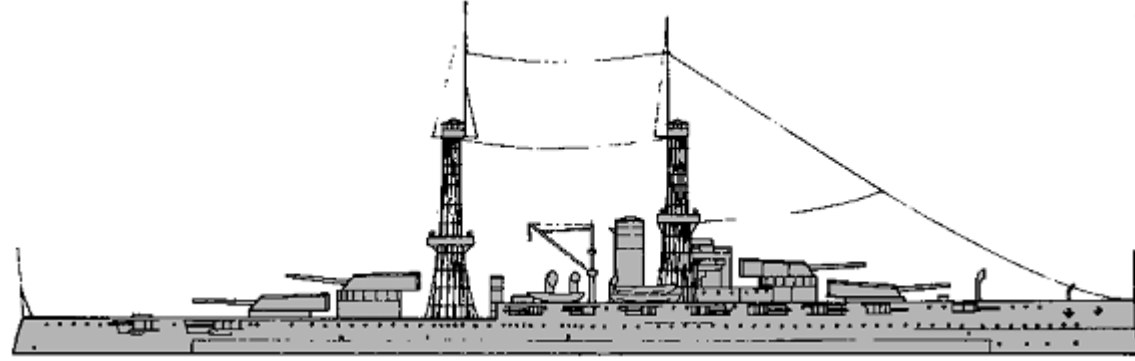
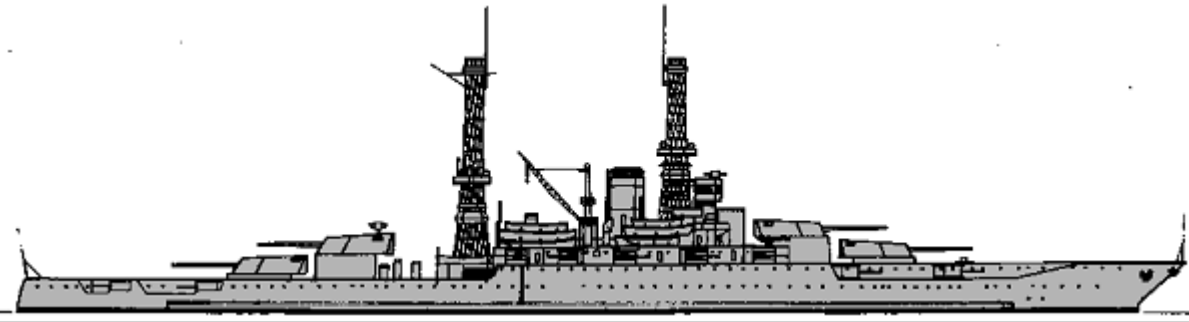
Wyoming	2	31	BB33	Arkansas	1912		27243t, 171.3x28.4x8.7m, 12b,4st, 28000hp, 20.5kts, 1063p; 279belt, 38deck, 305turrets, 292CT; 6x2-305/50, 16x1-127/51, 8x1-76/50, 2-533TT
New York	2	32	BB34	New York	1914		28367t, 174.7x29.1x8.7m, 14b,2vte, 28100hp, 21kts, 1042p; 305belt, 51deck, 356turrets, 305CT; 5x2-356/45, 21x1-127/51, 8x1-76/50, 4-533TT
		33	BB35	Texas	1914		
Nevada	2	34	BB36	Nevada	1916		28400t, 177.7x29.1x8.7m, 12b,2st(34)-12b,2vte(35), 26500(34)-24800(35)hp, 20.5kts, 864p; 343belt, 76deck, 457turrets, 406CT; (2x3+2x2)-356/45, 21x1-127/51, 8x1-76/50, 2-533TT
		35	BB37	Oklahoma	1916		
Pennsylvania	2	36	BB38	Pennsylvania	1916		32567t, 185.4x29.6x8.8m, 12b,4st, 31500hp, 21kts, 915p; 343belt, 76deck, 457turrets, 406CT; 4x3-356/45, 22x1-127/51, 8x1-76/50, 2-533TT
		37	BB39	Arizona	1916		
New Mexico	3	38	BB40	New Mexico	1918		33000t, 190.2x29.7x9.1m, 9b,2tg,4em(38)-9b,4st(39,40), 27500(38)-32000(39,40)hp, 21kts, 1084p; 343belt, 89deck, 457turrets; 406CT; 4x3-356/50, 14x1-127/51(38,40), 22x1-127/51(39), 4x1-76/50, 2-533TT
		39	BB41	Mississippi	1917		
		40	BB42	Idaho	1919		

MON	Amphitrite	1	1	BM3	Monadnock	1896	A side-view line drawing of the USS Amphitrite (BM-3), a monitor-class battleship. It features a single main gun turret on the deck and a complex superstructure with masts and rigging.	3990t, 79.9x16.9x4.4m, 4b,2hte, 3000hp, 14.5kts, 150-191p; steel, iron: 229belt, 44deck, 190turrets, 190CT; 2x2-254/31, 2x1-102/40, 2x1-57/40, 2x5-37/20
	Arkansas	2	BM7	Ozark	1902	A side-view line drawing of the USS Arkansas (BM-7), a monitor-class battleship. It has a single main gun turret and a superstructure similar to the Amphitrite but with a slightly different mast arrangement.	3225t, 77.8x15.2x3.8m, 4b,2vte, 2400hp, 12.5kts, 220p; Harvey: 279belt, 38deck, 254turret, 190CT; 1x2-305/40, 4x1-102/50, 3x1-57/40	
		3	BM8	Tonopah	1903			
		4	BM9	Tallahassee	1903			
		5	BM10	Cheyenne	1902			

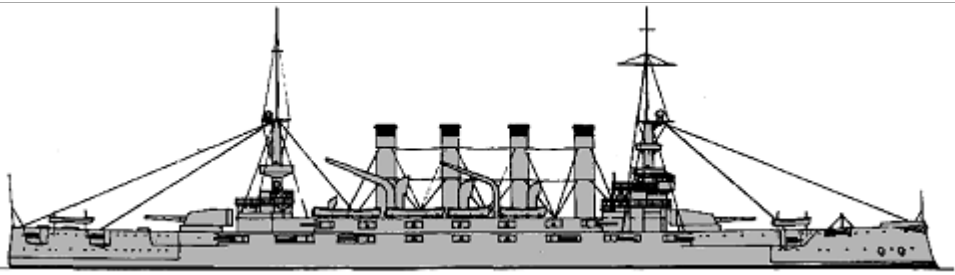
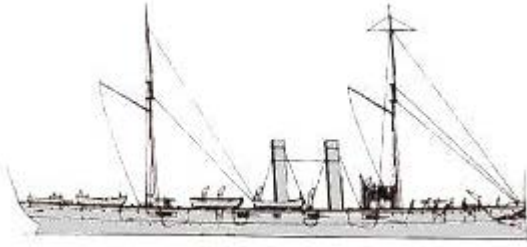
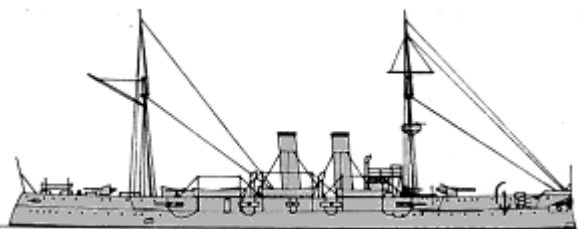
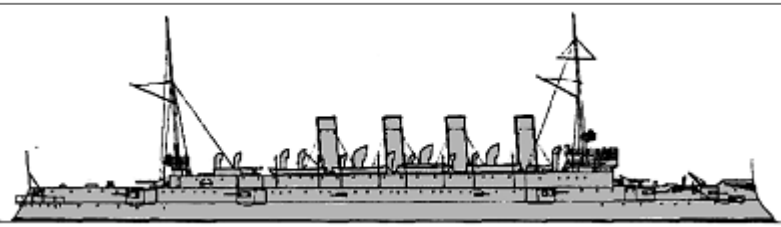
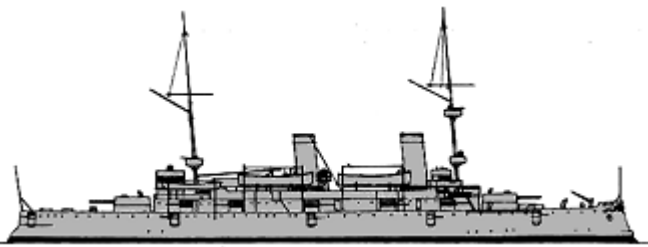
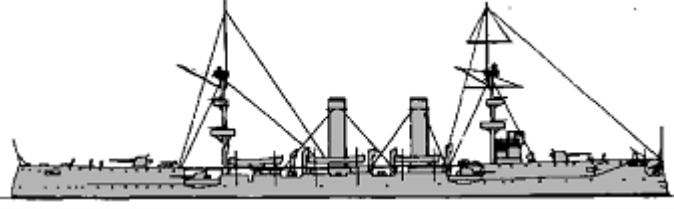
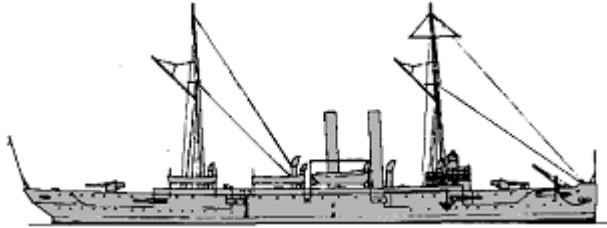

## CRUISERS

CA	New York	1	1	CA2	Rochester	1893	A side-view line drawing of the USS Rochester (CA-2), a protected cruiser. It has two masts, two funnels, and a complex rigging system.	9021t, 117.0x19.8x7.3m, 12b,2vte, 16000hp, 20kts, 566p; nickel steel: 102belt, 152deck, 165turrets, 190CT; 2x2-203/45, 8x1-127/50, 2x1-76/50
	Brooklyn	1	2	CA3	Brooklyn	1896	A side-view line drawing of the USS Brooklyn (CA-3), a protected cruiser. It features two masts, two funnels, and a complex rigging system.	10068t, 122.7x19.7x7.3m, 7b,2vte, 16000hp, 20kts, 581p; Harvey and nickel steel: 4x2-203/37, 8x1-127/40, 2x1-76.50, 12x1-57/45, 4x1-37/40
	Pennsylvania	3	CA4	Pittsburgh	1905	A side-view line drawing of the USS Pennsylvania (CA-4), a protected cruiser. It has two masts, two funnels, and a complex rigging system.	15138t, 153.6x21.2x7.3m, 16b,2vte, 23000hp, 22kts, 829-928p; 152belt, 102deck, 165turrets, 229CT; 2x2-203/45, 8x1-152/49(3), 4x1-152/49(4-7), 12x1-76/50, 12x1-47/45, 2x1-37/40, 2-450TT	
		4	CA5	Huntington	1905			
		5	CA7	Pueblo	1905			
		6	CA8	Frederick	1905			
	7	CA9	Huron	1908				
	St. Louis	8	CA18	St. Louis	1906	A side-view line drawing of the USS St. Louis (CA-18), a protected cruiser. It has two masts, two funnels, and a complex rigging system.	10839t, 129.9x20.1x6.9m, 16b,2vte, 21000hp, 22kts, 673-767p; Harvey: 102belt, 76deck, 102casemate, 127CT; 12x1-152/49, 6x1-76/50, 12x1-47/45, 8x1-37/40	
		9	CA19	Charleston	1905			
	Tennessee	10	CA11	Seattle	1906	A side-view line drawing of the USS Tennessee (CA-11), a protected cruiser. It has two masts, two funnels, and a complex rigging system.	15715(10)-15981(11,12)t, 153.8x22.2x7.6m, 16b,2vte, 23000hp, 22kts, 856-914p; 127belt, 102deck, 229turrets, 229CT; 2x2-254/40, 4x1-152/49, 14x1-76/50, 12x1-47/45, 2x1-37/40(10), 4x1-37/40(11,12), 4-533TT	
		11	CA12	Charlotte	1908			
		12	CA13	Missoula	1908			

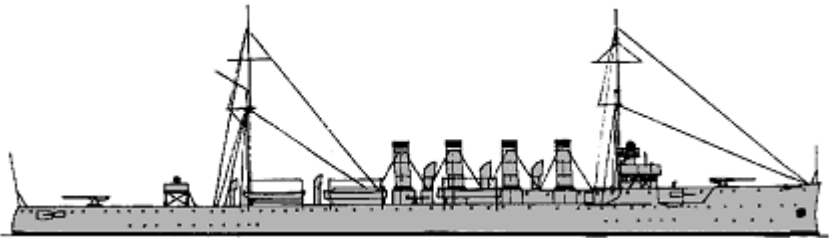
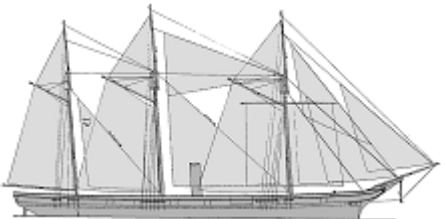
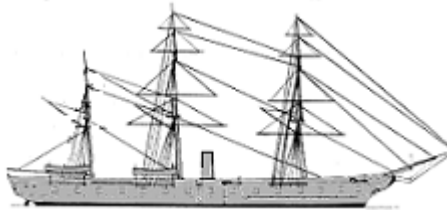

								
	Montgomery	1	1	PG27	Marblehead	1894		2235t, 82.1x11.3x4.4m, 6b,2vte, 5400hp, 17kts, 274p; steel: 13slopes, 13deck, 51CT; 8x1-102/50
	Cincinnati	2	2	C7	Cincinnati	1894		3339t, 93.2x12.8x5.5m, 8b,2vte, 10000hp, 19kts, 322p; steel: 64slopes, 25deck, 102shields, 51CT; 9x1-127/40, 4x1-57/45
			3	C8	Raleigh	1894		
	Columbia	2	4	CA16	Columbia	1894		8270t, 125.9x17.7x6.9m, 8b,3vte, 21000hp, 21kts, 477p; steel: 102slopes, 64deck, 102casemates, 127CT; 3x1-152/40, 12x1-102/40, 2x1-76/50, 12x1-57/45, 4x1-37/40
			5	CA17	Minneapolis	1894		
CL	Olympia	1	6	CA15	Olympia	1895		6558t, 104.9x16.2x6.6m, 6b,2vte, 13500hp, 20kts, 447p; Harvey: 121slopes, 51deck, 89turrets, 127CT; 10x1-127/51
	New Orleans	2	7	PG34	New Orleans	1898		4011t, 108.0x13.3x5.5m, 4b,2vte, 7500hp, 20kts, 366p; 89slopes, 32deck, 102CT; 8x1-127/50, 10x1-57/40, 8x1-37/20, 3-450TT
			8	PG36	Albany	1900		
	Denver	6	9	PG28	Denver	1904		3514t, 94.1x13.4x4.8m, 6b,2vte, 4500hp, 16.5kts, 339p; 64slopes, 8deck, 44casemates; 8x1-127/50, 8x1-57/50, 2x1-37/50
			10	PG29	Des Moines	1904		
			11	PG30	Chattanooga	1904		
			12	PG31	Galveston	1905		
			13	PG32	Tacoma	1904		
			14	PG33	Cleveland	1903		

CLL	Chester	1	CL1	Chester	1908		4687t, 129.0x14.3x5.1m, 12b,4st(1)-12b,2vte(2)-12b,2gt(3), 16000(1,2)-20000(3)hp, 24(1,3)-22.4(2)kts, 359p; 51belt, 25deck; 4x1-127/51, 3x1-76/50, 2x1-533TT	
		2	CL2	Birmingham	1908			
		3	CL3	Salem	1908			
SL	Alert	1	1	PG23	Nantucket	1876		1020t, 53.3ppx9.8x3.9m, 5b,1hcr, 380hp, 10kts, 148p; 1x1-135/21
	Enterprise	1	2	IX10	Essex (TS)	1876		1375t, 56.4ppx10.7x4.4m, 8b,1chr, 800hp, 11kts, 193p

### TORPEDO SHIPS

Paulding	10	1	DD22	Paulding	1910		887t, 89.6x8.0x2.4m, 4b,3st(1-4,7,8)-4b,2st(5,6,9)-4b,2gt(10), 12000(1-4,7,8)-10000(5,6,9)-13000hp, 29.5(1-4,7,8,10)-28(5,6,9)kts, 86p; 5x1-76/50, 3x2-450TT, 1dct, 2dcr
		2	DD23	Drayton	1910		
		3	DD24	Roe	1910		
		4	DD25	Terry	1910		
		5	DD26	Perkins	1910		
		6	DD27	Sterett	1910		
		7	DD28	McCall	1911		
		8	DD29	Burrows	1911		
		9	DD30	Warrington	1911		
		10	DD31	Mayrant	1911		
Monaghan	11	11	DD32	Monaghan	1911		883t, 89.5x8.2x2.5m, 4b,3st(11,12,14-17,19-21)-4b,2st(13)-4b,3gt(18), 12000(11,12,14-17,19-21)-10000(13)-13000(18)hp, 29.5(11,12,14-21)-28(13)kts, 89p; 5x1-76/50(11-18,20,21), 4x1-76/50(19), 3x2-450TT, 1dct, 2dcr
		12	DD33	Trippe	1911		
		13	DD34	Walke	1911		
		14	DD35	Ammen	1911		
		15	DD36	Patterson	1911		
		16	DD37	Fanning	1912		
		17	DD38	Jarvis	1912		
		18	DD39	Henley	1912		
		19	DD40	Beale	1912		
		20	DD41	Jouett	1912		
		21	DD42	Jenkins	1912		

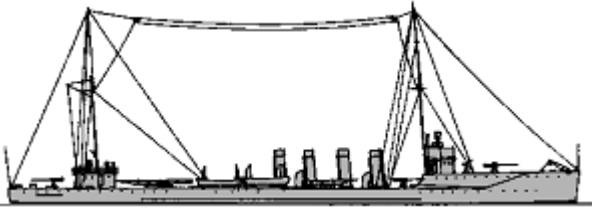
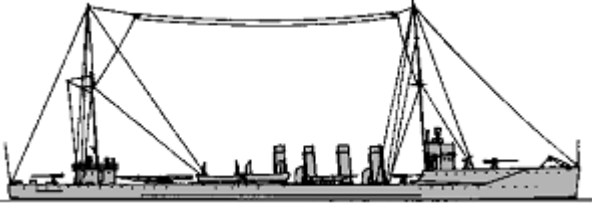
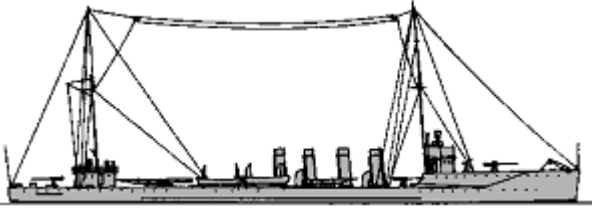
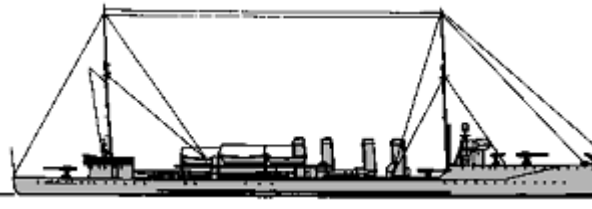
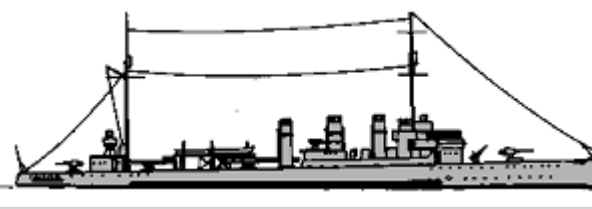

Cassin	8	22	DD43	Cassin	1913		1235t, 93.1x9.2x3.0m, 4b,2st/vte, 16000hp, 29kts, 98p; 3x1-102/50(22,23), 4x1-102/50(24-29), 4x2-450TT, 1dct, 2dcr
		23	DD44	Cummings	1913		
		24	DD45	Downes	1915		
		25	DD46	Duncan	1913		
		26	DD47	Aylwin	1914		
		27	DD48	Parker	1913		
		28	DD49	Benham	1914		
		29	DD50	Balch	1914		
O'Brien	6	30	DD51	O'Brien	1915		1171t, 93.1x9.5x2.9m, 4b,2st/vte(30-33,35)-4b,2st/st(34), 17000hp, 29kts, 101p; 4x1-102/50, 4x2-533TT
		31	DD52	Nicholson	1915		
		32	DD53	Winslow	1915		
		33	DD54	McDougal	1914		
		34	DD55	Cushing	1915		
		35	DD56	Ericsson	1915		
Tucker	5	36	DD57	Tucker	1916		1205t, 96.1x9.1(36,39,40)-9.3(37,38)x2.9(36-38,40)-2.8(39)m, 4b,2st/st(36-38,40)-4b,2gt(39), 17000(36,40)-18000(37,38)-17500(39)hp, 29.5kts, 99p; 4x1-102/50, 4x2-533TT, 1dct, 2dcr
		37	DD58	Conyngnam	1916		
		38	DD59	Porter	1916		
		39	DD60	Wadsworth	1915		
		40	DD62	Wainwright	1916		
Sampson	6	41	DD63	Sampson	1916		1225t, 96.1x9.1x2.9m, 4b,2st/st, 17500hp, 29.5kts, 99p; 4x1-102/50, 1x1-37/43, 4x3-533TT, 1dct, 2dcr
		42	DD64	Rowan	1916		
		43	DD65	Davis	1916		
		44	DD66	Allen	1917		
		45	DD67	Wilkes	1916		
		46	DD68	Shaw	1917		
Caldwell	5	47	DD69	Caldwell	1917		1187t, 96.2x9.3x2.7m, 4b,2gt(47,48,51)-4b,3st/st(49,50), 18500hp, 30kts, 100p; 4x1-102/50, 2x1-76/23, 4x3-533TT, 1dct, 2dcr
		48	DD70	Craven	1918		
		49	DD72	Conner	1918		
		50	DD73	Stockton	1917		
		51	DD74	Manley	1917		
		52	DD75	Wickes	1918		
		53	DD76	Philip	1918		
		54	DD77	Woolsey	1918		
		55	DD78	Evans	1918		
		56	DD79	Little	1918		
		57	DD80	Kimberly	1918		
		58	DD81	Sigourney	1918		
		59	DD82	Gregory	1918		
		60	DD83	Stringham	1918		
		61	DD84	Dyer	1918		

62	DD85	Colhoun	1918
63	DD86	Stevens	1918
64	DD87	McKee	1918
65	DD88	Robinson	1918
66	DD89	Ringgold	1918
67	DD90	McKean	1919
68	DD91	Harding	1919
69	DD92	Gridley	1919
70	DD93	Fairfax	1918
71	DD94	Taylor	1918
72	DD95	Bell	1918
73	DD96	Stribling	1918
74	DD97	Murray	1918
75	DD98	Israel	1918
76	DD99	Luce	1918
77	DD100	Maury	1918
78	DD101	Lansdale	1918
79	DD102	Mahan	1918
80	DD103	Schley	1918
81	DD104	Champlin	1918
82	DD105	Mugford	1918
83	DD106	Chew	1918
84	DD107	Hazelwood	1919
85	DD108	Williams	1919
86	DD109	Crane	1919
87	DD110	Hart	1919
88	DD111	Ingraham	1919
89	DD112	Ludlow	1918
90	DD113	Rathburne	1918
91	DD114	Talbot	1918
92	DD115	Waters	1918
93	DD116	Dent	1918
94	DD117	Dorsey	1918
95	DD118	Lea	1918
96	DD119	Lamberton	1918
97	DD120	Radford	1918
98	DD121	Montgomery	1918
99	DD122	Breese	1918
100	DD123	Gamble	1918
101	DD124	Ramsay	1919
102	DD125	Tattnall	1919

DD

Wickes





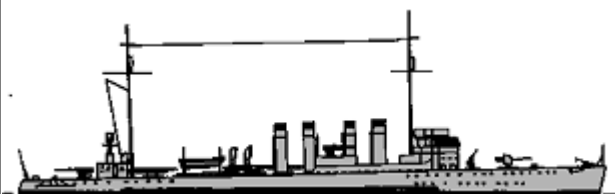

108

103	DD126	Badger	1919
104	DD127	Twiggs	1919
105	DD128	Babbitt	1919
106	DD129	De Long	1919
107	DD130	Jacob Jones	1919
108	DD131	Buchanan	1919
109	DD132	Aaron Ward	1919
110	DD133	Hale	1919
111	DD134	Crowningshield	1919
112	DD136	Boggs	1918
113	DD137	Kilty	1918
114	DD138	Kennison	1919
115	DD139	Ward	1919
116	DD140	Claxton	1919
117	DD141	Hamilton	1919
118	DD142	Tarbell	1918
119	DD143	Yarnall	1918
120	DD144	Upshur	1918
121	DD145	Greer	1918
122	DD146	Elliot	1919
123	DD147	Roper	1919
124	DD148	Breckinridge	1919
125	DD149	Barney	1919
126	DD150	Blakeley	1919
127	DD151	Biddle	1919
128	DD152	Du Pont	1919
129	DD153	Bernadou	1919
130	DD154	Ellis	1919
131	DD155	Cole	1919
132	DD156	J. Fred Talbott	1919
133	DD157	Dickerson	1919
134	DD158	Leary	1919
135	DD159	Schenck	1919
136	DD160	Herbert	1919
137	DD161	Palmer	1918
138	DD162	Thatcher	1919
139	DD163	Walker	1919
140	DD164	Crosby	1919
141	DD165	Meredith	1919
142	DD166	Bush	1919

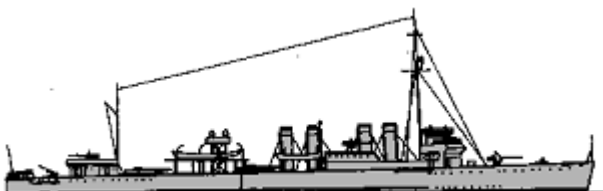









1247t, 95.8x9.4x2.8m, 4b,2st/gt, 27000(52-101,108-132,137-159)-24900(102-107)-26000(133-136)hp, 35kts, 114p; 4x1-102/50, 2x1-76/23, 4x3-533TT, 1dct, 2dcr

143	DD167	Cowell	1919
144	DD168	Maddox	1919
145	DD169	Foote	1919
146	DD170	Kalk	1919
147	DD171	Burns	1919
148	DD172	Anthony	1919
149	DD173	Sproston	1919
150	DD174	Rizal	1919
151	DD175	Mackenzie	1919
152	DD176	Renshaw	1919
153	DD177	O`Bannon	1919
154	DD178	Hogan	1919
155	DD181	Hopewell	1919
156	DD182	Thomas	1919
157	DD183	Haraden	1919
158	DD184	Abbot	1919
159	DD185	Bagley	1919
160	DD186	Clemson	1919
161	DD190	Satterlee	1919
162	DD206	Chandler	1919
163	DD207	Southard	1919
164	DD208	Hovey	1919
165	DD209	Long	1919
166	DD210	Broome	1919
167	DD211	Alden	1919
168	DD212	Smith Thompson	1919
169	DD213	Barker	1919
170	DD251	Belknap	1919
171	DD252	McCook	1919
172	DD253	McCalla	1919
173	DD254	Rodgers	1919
174	DD255	Osmond Ingram	1919
175	DD256	Bancroft	1919
176	DD257	Welles	1919
177	DD258	Aulick	1919
178	DD259	Turner	1919
179	DD260	Gillis	1919
180	DD261	Delphy	1918
181	DD262	McDermut	1919

Clemson	49	182	DD263	Laub	1919		1308t, 95.8x9.4x3.0m, 4b,2gt, 27000hp, 35kts, 114p; 4x1-102/50(160-163,166-208), 4x2-102/50(164,165), 1x1-76/23, 4x3-533TT, 1dct, 2dcr	
		183	DD264	McLanahan	1919			
		184	DD265	Edwards	1919			
		185	DD266	Greene	1919			
		186	DD267	Ballard	1919			
		187	DD268	Shubrick	1919			
		188	DD269	Bailey	1919			
		189	DD270	Thornton	1919			
		190	DD271	Morris	1919			
		191	DD272	Tingey	1919			
		192	DD273	Swasey	1919			
		193	DD274	Meade	1919			
		194	DD275	Sinclair	1919			
		195	DD276	McCawley	1919			
		196	DD277	Moody	1919			
		197	DD278	Henshaw	1919			
		198	DD279	Meyer	1919			
		199	DD280	Doyen	1919			
		200	DD281	Sharkey	1919			
		201	DD282	Toucey	1919			
202	DD283	Breck	1919					
203	DD284	Isherwood	1919					
204	DD285	Case	1919					
205	DD286	Lardner	1919					
206	DD287	Putnam	1919					
207	DD292	Reid	1919					
208	DD296	Chauncey	1919					
TB	Cushing	1	1	TB1	Cushing	1890		116t, 42.7x4.6x1.5m, 2b,2vqe, 1600hp, 23kts, 22p; 3x1-57/40, (1+2x1)-450TT
	Foote	1	2	CTB1		1897		142t, 48.8x4.9x1.5m, 2b,2vte, 2000hp, 25kts, 20p; 3x1-37/40, 3x1-450TT
	Porter	1	3	CTB3		1897		165t, 53.5x5.4x1.4m, 3b,2vqe, 3200hp, 27.5kts, 24p; 4x1-37/40, 3x1-450TT
	Morris	1	4	CTB6		1898		105t, 42.5x4.7x1.2m, 2b,2vte, 1750hp, 23kts, 26p; 3x1-37/40, 3x1-450TT
	Somers	1	5	CTB9		1898	No picture	143t, 47.6x5.3x1.8m, 1b,1vqe, 1700hp, 23kts, 24p; 4x1-37/40, (1+2x1)-450TT
	Davis	1	6	TB12	Davis	1899		155t, 45.1x4.7x1.8m, 2b,2vte, 1750hp, 23kts, 24p; 3x1-37/40, 3x1-450TT
	Dahlgren	1	7	CTB4		1900		146t, 46.1x5.0x1.4m, 2b,2vte, 4200hp, 31kts, 29p; 4x1-37/40, 2x1-450TT
			8	CTB11		1901		

Bagley	2	9	CTB12	1901	No picture	168t, 47.9x5.2x1.5m, 2b,2vte, 4200hp, 28kts, 29p; 3x1-37/40, 3x1-450TT
Blakely	2	10	CTB13	1904		196t, 53.4x5.2x1.8m, 3b,2vte, 3000hp, 26kts, 28-29p; 3x1-37/40, 3x1-450TT
		11	CTB14	1902		

## SUBMARINES

A	6	1	SS3	A2	1903		107/123t, 19.5x3.6x3.2m, 1pe/em, 160/150hp, 8/7kts, 7p, 25m; 1-450TT
		2	SS4	A3	1903		
		3	SS5	A4	1903		
		4	SS6	A5	1903		
		5	SS7	A6	1903		
		6	SS8	A7	1903		
B	2	7	SS10	B1	1907		145/173t, 25.1x3.8x3.2m, 1pe/em, 250/150hp, 9/8kts, 10p, 45m; 2-450TT
		8	SS12	B3	1907		
D	3	9	SS17	D1	1909		288/337t, 41.1x4.2x3.6m, 2pe/em, 600/260hp, 12/9.5kts, 15p, 60m; 4-450TT
		10	SS18	D2	1909		
		11	SS19	D3	1910		
E	2	12	SS24	E1	1912		287/342t, 41.2x4.4x3.6m, 2d/em, 700/600hp, 13.5/11.5kts, 20p, 60m; 4-450TT
		13	SS25	E2	1912		
F	2	14	SS21	F2	1912		330/400t, 43.5x4.7x3.7m, 2d/em, 780/620(14)-800/620(15)hp, 13.5/11.5kts, 22p, 60m; 4-450TT
		15	SS22	F3	1912		
G	2	16	SS19 <sup>1/2</sup>	G1	1912		400/516(16)-393/460(17)t, 49.1x4.0x3.8m, 2pe/em(16)-2d/em(17), 600/520(16)-1200/600(17)hp, 10/10(16)-14/9.5(17)kts, 24(16)-25(17)p, 60m; 6-450TT
		17	SS31	G3	1914		
H	9	18	SS28	H1	1913		358/467t, 45.8x4.8x3.8m, 2d/em, 950/600hp, 14/10.5kts, 25p, 60m; 4-450TT
		19	SS29	H2	1913		
		20	SS30	H3	1914		
		21	SS147	H4	1918		
		22	SS148	H5	1918		
		23	SS149	H6	1918		
		24	SS150	H7	1918		
		25	SS151	H8	1918		
		26	SS152	H9	1918		
K	8	27	SS32	K1	1914		392/521t, 46.9x5.1x4.0m, 2d/em, 950/680hp, 14/10.5kts, 28p, 60m; 4-450TT
		28	SS33	K2	1914		
		29	SS34	K3	1914		
		30	SS35	K4	1914		
		31	SS36	K5	1914		
		32	SS37	K6	1914		
		33	SS38	K7	1914		
		34	SS39	K8	1914		

L	11	35	SS40	L1	1916		450/548(35-38,43-45)-456/524(39-42)t, 51.0(35-38,43-45)-50.3(39-42)x5.3(35-38,43-45)-4.5(39-42)x4.1(35-38,43-45)-4.0(39-42)m, 2d/em, 1200/800hp, 14/10.5kts, 28p, 60m; 1x1-76/23(39-42), 4-450TT	
		36	SS41	L2	1916			
		37	SS42	L3	1916			
		38	SS43	L4	1916			
		39	SS44	L5	1918			
		40	SS45	L6	1917			
		41	SS46	L7	1917			
		42	SS48	L8	1917			
		43	SS49	L9	1916			
		44	SS50	L10	1916			
		45	SS51	L11	1916			
SS	N	7	46	SS53	N1	1917		348/414(46-48)-340/414(49-52)t, 44.9(46-48)-47.3(49-52)x4.8(46-48)-4.4(49-52)x3.8m, 2d/em, 600/300hp, 13/11kts, 25(46-48)-29(49-52)p, 60m; 4-450TT
			47	SS54	N2	1917		
			48	SS55	N3	1917		
			49	SS56	N4	1918		
			50	SS57	N5	1918		
			51	SS58	N6	1918		
			52	SS59	N7	1918		
	M	1	53	SS47	M1	1918		488/676t, 59.8x5.8x3.4m, 2d/em, 840/680hp, 14/10.5kts, 28p, 60m; 1x1-76/23, 4-450TT
O	16	54	SS62	O1	1918		521/629(54-63)-491/566(64-69)t, 52.5(54-63)-52.4(64-69)x5.5(54-63)-5.1(64-69)x4.4(54-63)-4.2(64-69)m, 2d/em, 600/550(54-63)-880/740(64-69)hp, 13/11(54-63)-14/10.5(64-69)kts, 25(54-63)-29(64-69)p, 60m; 1x1-76/23, 4-450TT	
		55	SS63	O2	1918			
		56	SS64	O3	1918			
		57	SS65	O4	1918			
		58	SS66	O5	1918			
		59	SS67	O6	1918			
		60	SS68	O7	1918			
		61	SS69	O8	1918			
		62	SS70	O9	1918			
		63	SS71	O10	1918			
		64	SS72	O11	1918			
		65	SS73	O12	1918			
		66	SS74	O13	1918			
67	SS75	O14	1918					
68	SS76	O15	1918					
69	SS77	O16	1918					
			70	SS78	R1	1918		
			71	SS79	R2	1919		
			72	SS80	R3	1919		
			73	SS81	R4	1919		

R	27	74	SS82	R5	1919		569/680(70-89)-510/583(90-96)t, 56.8(70-89)-53.3(90-96)x5.5(70-89)-5.1(90-96)x4.4m, 2d/em, 1200/940(70-89)-1000/800(90-96)hp, 13.5/11(70-89)-14/11(90-96)kts, 29p, 60m; 1x1-76/50, 4-533TT(70-89), 4-450TT(90-96)
		75	SS83	R6	1919		
		76	SS84	R7	1919		
		77	SS85	R8	1919		
		78	SS86	R9	1919		
		79	SS87	R10	1919		
		80	SS88	R11	1919		
		81	SS89	R12	1919		
		82	SS90	R13	1919		
		83	SS91	R14	1919		
		84	SS92	R15	1918		
		85	SS93	R16	1918		
		86	SS94	R17	1918		
		87	SS95	R18	1918		
		88	SS96	R19	1918		
		89	SS97	R20	1918		
		90	SS98	R21	1919		
		91	SS99	R22	1919		
92	SS100	R23	1919				
93	SS101	R24	1919				
94	SS102	R25	1919				
95	SS103	R26	1919				
96	SS104	R27	1919				
S IV	2	97	SS107	S3	1919		875/1088(97)-876/1092(98)t, 70.4x6.7x4.0m, 2d/em, 1400/1200(97)-2000/1200(98)hp, 15/11kts, 38p, 60m; 1x1-102/50, 5-533TT
		98	SS109	S4	1919		

ESCORTS

		1	PE1	Eagle No1	1918		
		2	PE2	Eagle No2	1918		
		3	PE3	Eagle No3	1918		
		4	PE4	Eagle No4	1918		
		5	PE5	Eagle No5	1918		
		6	PE6	Eagle No6	1918		
		7	PE7	Eagle No7	1918		
		8	PE8	Eagle No8	1919		
		9	PE9	Eagle No9	1919		
		10	PE10	Eagle No10	1919		
		11	PE11	Eagle No11	1919		
		12	PE12	Eagle No12	1919		



PC	Eagle	60	13	PE13	Eagle No13	1919
			14	PE14	Eagle No14	1919
			15	PE15	Eagle No15	1919
			16	PE16	Eagle No16	1919
			17	PE17	Eagle No17	1919
			18	PE18	Eagle No18	1919
			19	PE19	Eagle No19	1919
			20	PE20	Eagle No20	1919
			21	PE21	Eagle No21	1919
			22	PE22	Eagle No22	1919
			23	PE23	Eagle No23	1919
			24	PE24	Eagle No24	1919
			25	PE25	Eagle No25	1919
			26	PE26	Eagle No26	1919
			27	PE27	Eagle No27	1919
			28	PE28	Eagle No28	1919
			29	PE29	Eagle No29	1919
			30	PE30	Eagle No30	1919
			31	PE31	Eagle No31	1919
			32	PE32	Eagle No32	1919
			33	PE33	Eagle No33	1919
			34	PE34	Eagle No34	1919
			35	PE35	Eagle No35	1919
			36	PE36	Eagle No36	1919
			37	PE37	Eagle No37	1919
			38	PE38	Eagle No38	1919
			39	PE39	Eagle No39	1919
			40	PE40	Eagle No40	1919
			41	PE41	Eagle No41	1919
			42	PE42	Eagle No42	1919
			43	PE43	Eagle No43	1919
			44	PE44	Eagle No44	1919
			45	PE45	Eagle No45	1919
			46	PE46	Eagle No46	1919
			47	PE47	Eagle No47	1919
			48	PE48	Eagle No48	1919
			49	PE49	Eagle No49	1919
			50	PE50	Eagle No50	1919
			51	PE51	Eagle No51	1919
			52	PE52	Eagle No52	1919
			53	PE53	Eagle No53	1919





615t, 61.2x10.1x2.6m, 2b,1gt, 2500hp, 18.3kts, 61p; 2x1-102/50, 1x1-76/50, 1dct

			54	PE54	Eagle No54	1919	
			55	PE55	Eagle No55	1919	
			56	PE56	Eagle No56	1919	
			57	PE57	Eagle No57	1919	
			58	PE58	Eagle No58	1919	
			59	PE59	Eagle No59	1919	
			60	PE60	Eagle No60	1919	
AY	-	11	1	PY1	Mayflower	1896	2690t, 83.2x11.0x5.3m, 2vte, 4700hp, 16.8kts; 2x1-127/40, 12x1-57/40
			2		Eagle	1890	850t
			3	PY2	Hawk	1891	545t
			4	PY3	Scorpion	1896	850t
			5	PY4	Vixen	1896	806t
			6	PY6	Nokomis	1914	1265t, 74.1x9.7m, 16kts; 4x1-76/50
			7	PY7	Aramis	1916	375t
			8		Wasp	1898	630t
			9	PY8	Despatch	1913	237t
			10	PY9	Niagara	1898	2690t, 86.0x13.1m, 2vte, 1800hp, 12kts; 4x1-102/40, 1dct
			11	PY10	Isabel	1917	710t; 4x1-76/50, 4-533TT
APV	-	42	1	SP1298	Charles	1907	3737t, 122.9x15.6m, 3vte, 22kts
			2	SP2005	Astoria	1902	7150t, 97.5x14.0m, 9.5kts; 4x1-76/50
			3	SP2196	Narragansett	1913	19503t, 97.7x14.7m, vc(sw)
			4	SP156	Winchester	1916	399t; 1x1-76/50
			5	SP157	Remlik	1903	600t; 2x1-76/50
			6	SP165	Wenonah	1915	470t, 2x1-76/50
			7	SP175	Emeline	1898	407t; 2x1-76/50
			8	SP249	California	1902	299t
			9	SP265	Pocomoke	1902	139t
			10	SP370	Nonpareil	1904	167t
			11	SP390	Catherine Johnson	1913	196t
			12	SP399	Legonia	1909	119t
			13	SP415	Kemah	1917	300t; 2x1-76/50
			14	SP467	Delaware	1913	242t
			15	OYP519	Vergana	1897	128t
			16	SP527	Margaret	1899	245t; 2x1-76/50
			17	SP573	East Hampton	1913	407t
			18	SP617	Yacona	1898	527t; 2x1-76/50
			19	SP648	George F. Pierce	1914	252t
			20	SP671	Parthenia	1903	144t
			21	SP680	Ardent	1902	106t
			22	SP686	Vester	1876	117t

23	SP714	Galatea	1914	367t; 3x1-76/50
24	SP724	Fearless	1877	121t
25	SP734	Vega	1905	276t; 1x1-76/50
26	SP765	Adelante	1883	142t
27	SP773	Concord	1898	353t; 1x1-76/50
28	SP838	John L. Lawrence	1877	150t
29	SP876	Lykens	1899	425t; 1x1-76/50
30	SP951	Utowana	1891	414t
31	SP982	Penobscot	1904	415t; 1x1-76/50
32	SP1121	Chase S. Osborne	1906	492t; 1x1-76/50
33	SP1149	Barnett	1911	194t
34	SP1163	Narragansett	1905	250t
35	SP1213	Montauk	1899	424t; 1x1-76/50
36	SP1250	Nahant	1913	405t; 1x1-76/50
37	SP1275	Bouker No.2	1904	179t
38	SP1494	Goliath	1907	414t; 1x1-76/50
39	SP2225	Navigator	1898	470t
40	SP2725	Alex Brown	1912	119t
41	SP3104	Asher J. Hudson	1891	136t
42	SP3158	Bessie H. Dantzer	1901	108t

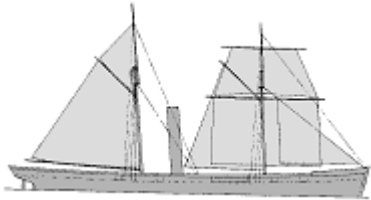
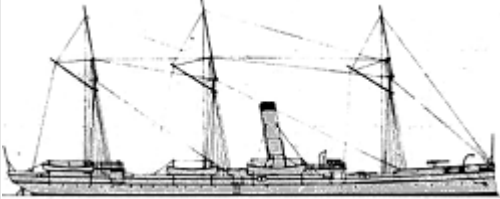
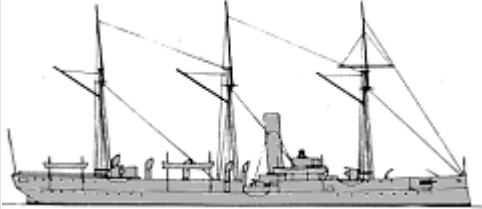
## OTHER FIGHTING SHIPS

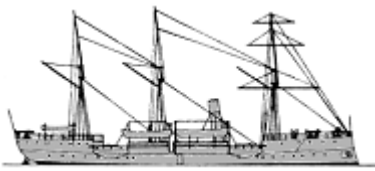
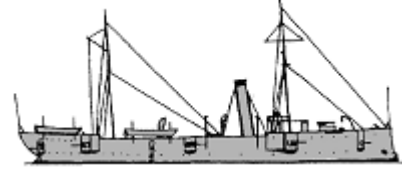
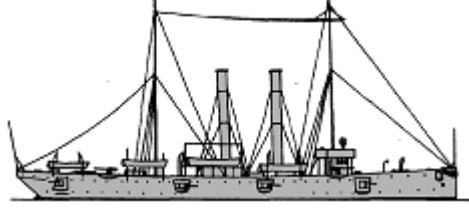
Kansas	1	1		Yantic	1864		836t, 54.7ppx9.1x3.5m, 2b,1hdase, 310hp, 10kts, 96p; 4x1-47/40
Dolphin	1	2	PG24	Dolphin	1884		1486t, 78.2x9.8x4.4m, 4b,1vc, 2255hp, 16kts, 152p; 6x1-47/45
Yorktown	1	3	PG1	Yorktown	1889		1921t, 74.5x11.0x4.3m, 4b,2hte, 3400hp, 16kts, 187-201p; 51CT; 6x1-127/40, 4x1-57/50, 1x1-37/40
Petrel	1	4	PG2	Petrel	1889		867t, 57.3x9.4x3.5m, 4b,1hce, 1000hp, 11.4kts, 138p; 4x1-102/40, 2x1-47/40, 1x1-37/40, 1x1-37/40

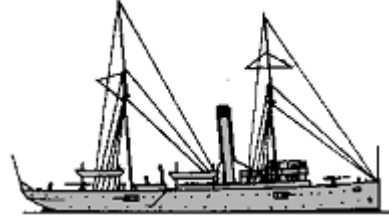
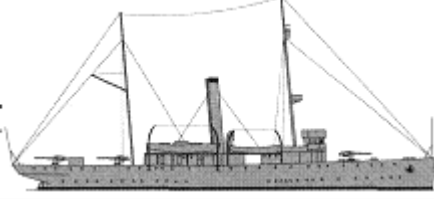
								
PG	Machias	5	PG5	Machias	1893		1318t, 62.2x9.8x3.7m, 2b,2vte, 1900hp, 15.5kts, 154p; 4x1-102/50(5), 2x1-102/40(6), 6x1-57/50(6), 2x1-47/45(5)	
		6	PG6	Castine	1894			
	Nashville	1	7	PG7	Nashville	1897		1719t, 71.2x11.6x3.4m, 6b,2vqe, 2530hp, 16.3kts, 180p; 64sponsons; 8x1-102/40, 4x1-57/50, 2x1-37/40
	Wilmington	8	PG8	Wilmington	1897		1689t, 76.4x12.5x2.7m, 6b,2vte, 1900hp, 15kts, 183-199p; 25belt, 38deck, 8x1-102/40, 4x1-47/45	
		9	PG9	Helena	1897			
	Annapolis	10	PG10	Annapolis	1897	No picture	1000-1153t, 62.3x11.0x3.7-3.9m, 2b,1vte, 1000hp, 11-13kts, 135-156p; 6x1-102/40, 4x1-57/50, 2x1-37/40	
		11	PG11	Vicksburgh	1897			
	Wheeling	1	12	PG14	Wheeling	1897		1170t, 57.8x10.4x3.7m, 2b,2vte, 1050hp, 13kts, 140p; 4x1-102/40, 4x1-57/50, 2x1-37/40
	Callao	13	PG37	Callao	1889	No picture	243t, 34.8x5.3x2.0m, 1b,2vc, 275hp, 10-10.5kts, 35p; 1x1-57/50(13,15), 3x1-47/45(13), 4x1-47/45(14), 1x1-47/45(15), 2x1-37/40(15)	
		14	PG39	Pampanga	1889			
15		PG41	Samar	1888				
Quiros	16	PG40	Quiros	1897	No picture	350-370t, 44.2x6.9x2.4m, 2b,1vte, 450hp, 11kts, 44-57p; 4x1-47/45(17), 2x1-37/40(17)		
	17	PG42	Villalobos	1896				
Elcano	1	18	PG38	Elcano	1885	No picture	620t, 50.4x7.9x3.1m, 2b,2vc, 1200hp, 11kts, 103p; 4x1-102/40, 4x1-47/45	
Sacramento	1	19	PG19	Sacramento	1914		1592t, 69.0x12.5x3.5m, 2b,1vte, 950hp, 12.5kts, 163p; 3x1-102/50, 2x1-47/45, 2x1-37/40	
PR	Palos	1	PG16	Palos	1914		204t, 48.8x7.5x0.7m, 2b,2vte, 800hp, 13.3kts, 47p; 2x1-57/50	
		2	PG20	Monocacy	1914			

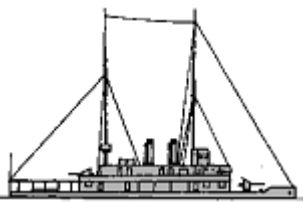
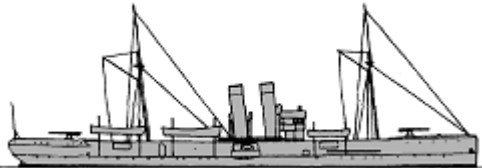
								
APG	-	1	1	PG35	Topeka	1881		2372t, 76.2x10.7x5.4m, 4b,2hce, 2200hp, 16kts; 8x1-102/40, 2x1-57/50, 4x1-47/45, 2x1-37/40

### COASTAL FORCES

SC	SC	110ft	290	1 - 290	SC1-4, 6, 17-21, 23-26, 34-37, 39-64, 68-74, 77, 79-81, 83-93, 95-107, 109-127, 129-138, 143-145, 147-151, 154, 156-159, 164-168, 174, 178-196, 198, 200-202, 204-214, 216-232, 235-242, 244-247, 250-266, 268-273, 276-278, 282-301, 303-310, 320-326, 328-334, 336-346, 349, 351-356, 407-409, 411-413, 418-432, 434, 436, 439-441, 443, 444	1917 - 1919		85t, 33.5x4.5x1.7m, 3pe, 660hp, 18kts, 27p; 1x1-76/23 or 1x1-76/24, 1dct
----	----	-------	-----	---------	--	-------------	---	--

### MINE WARFARE SHIPS

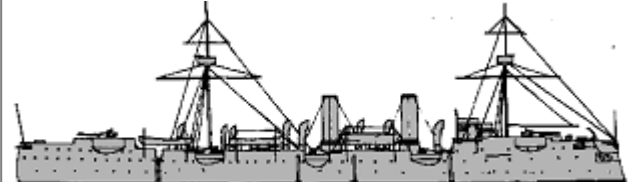
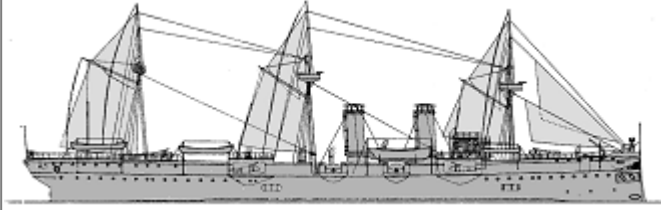
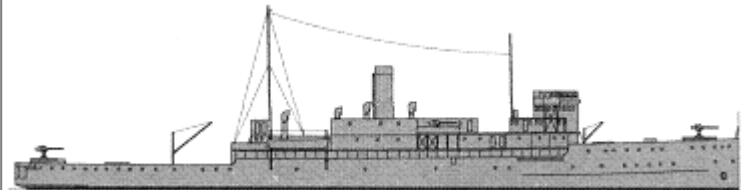
	Baltimore	1	1	CM1	Baltimore	1890		5436t, 102.1x14.8x5.9m, 8b,2hte, 10750hp, 19kts, 386p; steel: 102slopes, 64deck, 76CT; 4x1-127/51, 2x1-76/50, 180mines
ML	San Francisco	1	2	CM2	San Francisco	1890		4583t, 98.9x15.0x5.7m, 8b,2hte, 10500hp, 19kts, 384p; steel: 76slopes, 51deck, 76CT; 4x1-127/51, 180mines
	Aroostook	2	3	CM3	Aroostook	1907		4200t, 120.4x15.9x4.9m, 8b,2vte, 7000hp, 20kts, 314p; 1x1-127/51, 2x1-76/50, 300mines
			4	CM4	Shawmut	1907		
			1	AM1	Lapwing	1918		
			2	AM2	Owl	1918		
			3	AM3	Robin	1918		
			4	AM4	Swallow	1918		
			5	AM5	Tanager	1918		
			6	AM6	Cardinal	1918		

MS Bird

48

7	AM7	Oriole	1918
8	AM8	Curlew	1919
9	AM9	Finch	1918
10	AM10	Heron	1918
11	AM13	Turkey	1918
12	AM14	Woodcock	1919
13	AM15	Quail	1919
14	AM16	Partridge	1919
15	AM17	Eider	1919
16	AM18	Thrush	1919
17	AM19	Avocet	1919
18	AM20	Bobolink	1919
19	AM21	Lark	1919
20	AM22	Widgeon	1918
21	AM23	Teal	1918
22	AM24	Brant	1918
23	AM25	Kingfisher	1918
24	AM26	Rail	1918
25	AM27	Pelican	1918
26	AM28	Falcon	1918
27	AM29	Osprey	1919
28	AM30	Seagull	1919
29	AM31	Tern	1919
30	AM32	Flamingo	1919
31	AM33	Penguin	1919
32	AM34	Swan	1919
33	AM35	Whippoorwill	1919
34	AM36	Bittern	1919
35	AM37	Sanderling	1918
36	AM38	Auk	1919
37	AM39	Chewink	1919
38	AM40	Cormorant	1919
39	AM41	Gannet	1919
40	AM43	Grebe	1919
41	AM44	Mallard	1919
42	AM45	Ortolan	1919
43	AM46	Peacock	1919
44	AM47	Pigeon	1919
45	AM48	Redwing	1919
46	AM51	Sandpiper	1919
47	AM52	Vireo	1919

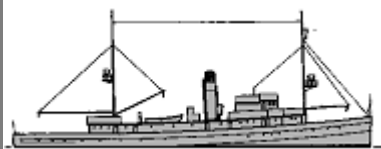

1400t, 57.6x10.8x3.8m, 2b,1vte, 1400hp, 13.5kts, 85p; 2x1-76/50, sweeps, mines

## COAST GUARD CUTTERS

CGC	Manhattan	1	1		Arundel	1873	No picture	147t, 31.1x6.2x2.6m, 1vce, 16p; 1x1-57/40
	Bear	1	2		Bear	1874	No picture	703t, 60.5x9.2x5.5m, 1b,1vce, 51p; 3x1-57/40
	Lot M. Morrill	1	3		Lot M. Morrill	1889	No picture	288t, 44.3x7.3x2.9m, 1b,1vce, 13kts, 38p; 1x1-76/50, 2x1-57/40
	Galveston	1	4		Apache	1891	No picture	708t, 57.9x8.8x2.8m, 2b,1vte, 1200hp, 12kts, 41p; 3x1-76/50
	Bancroft	1	5		Itasca	1893	No picture	839t, 57.6x9.8x3.7m, 2b,2vte, 1200hp, 14.5kts, 148p; 4x1-57/50
	William Windom	1	6		Comanche	1896	No picture	670t, 52.0x8.2x2.9m, 2b,2vte, 800hp, 15kts, 49p; 1x1-76/50, 2x1-57/40
	Gresham	4	7	CG1	Gresham	1897	No picture	1190t, 62.6x9.8x3.4m, 4b,1vte(7,10)-2b,1vte(8,9), 2500hp, 17kts, 73p; 4x1-102/50(8), 4x1-76/50(7,9), 4x1-57/40(10)
			8	CG2	Manning	1898		
			9	CG4	Algonquin	1898		
			10	CG5	Onondaga	1898		
	Seminole	1	11		Seminole	1900	No picture	860t, 57.3x8.8x3.4m, 2b,1vte, 14.7kts, 67p; 4x1-76/50
	Tuscarora	1	12		Tuscarora	1902	No picture	739t, 54.3x9.1x3.4m, 2b,1vte, 14.2kts, 65p; 1x1-76/50, 2x1-57/45
	Pamlico	1	13	CG15	Pamlico	1907	No picture	455t, 48.2x9.1x1.7m, 1b,2vte, 600hp, 9.8kts, 33p; 2x1-57/45
	Androscoggin	1	14	CG14	Androscoggin	1908	No picture	1605t, 64.0x10.7x5.3m, 2b,1vte, 1800hp, 13kts, 74p; 3x1-76/50, 1x1-57/45
	Tahoma	1	15	CG21	Yamacraw	1909	No picture	1082t, 58.2x9.8x4.3m, 1vte, 14.1kts, 69p; 2x1-76/50
	Snohomish	2	16	CG16	Snohomish	1908	No picture	879t, 46.3x8.8x4.2m, 1b,1vte, 1200hp, 12kts, 53p; 1x1-76/50, 2x1-57/50
			17		Acushnet	1908		
	Seneca	1	18	CG17	Seneca	1908	No picture	1445t, 62.2x10.4x5.2m, 2b,1vte, 1500hp, 12.5kts, 74p; 4x1-102/50
	Miami	1	19	CG53	Unalga	1912	No picture	1181t, 57.9x9.9x4.3m, 1vte, 1300hp, 13kts; 2x1-102/50, 2x1-76/50
-	1	20		Pequot	1912		276t	
Ossipee	2	21	CG26	Ossipee	1915	No picture	997t, 50.5x9.8x3.6m, 2b,1vte, 1000hp, 12.7kts, 72p; 2x1-57/50, 1dct	
		22	CG27	Tallapoosa	1915			
SC	SC 110ft	16	1 - 16		Quigley, Richards, Vaughan, Taylor, Smith, Mehalatos, Ovensen, Larsen, Cygan, Hahn, Stellenwerf, Knudsen, Klingelhoef, Johansson, Boyce, Cook	1917 - 1919		85t, 33.5x4.5x1.7m, 3pe, 660hp, 18kts, 27p; 1x1-76/23 or 1x1-76/24, 1dct





[home](#)[World navies yesterday](#)[1920](#)

## Uruguay 01 January 1920

### CRUISERS

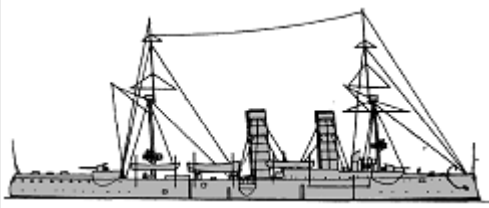
CL	24 de Agosto	1	1	Montevideo	1887		2050t, 76.2x11.3x4.4m, 4b,2vte, 5012hp, 17.7kts, 250p; compound- 51deck, 114shields, 51CT; 6x1-152/32, 9x1-57/40, 4-350TT
----	--------------	---	---	------------	------	--	---

### TORPEDO SHIPS

PGT	Uruguay	1	1	Uruguay	1910		1400t, 85.0ppx9.4x3.6m, 4b,2vte, 5700hp, 23kts, 125p; steel- 17deck; 2x1-120/45, 4x1-76/40, 6x1-37/40, 2x1-450TT
-----	---------	---	---	---------	------	---	--

### ESCORTS

AY	-	1	1	18 de Julio		1884	678t
----	---	---	---	-------------	--	------	------

© Ivan Gogin, 2015

[home](#)[World navies yesterday](#)[1920](#)

## Venezuela 01 January 1920

### TORPEDO SHIPS

PGT	Bolívar	1	1	Bolívar	1894		630t, 58.0ppx6.7x3.2m, 4b,2vte, 2600hp, 19kts, 91p; steel- 13deck; 2x1-120/35, 4x1-57/42, 1x4-25/42, 2x1-356TT
-----	---------	---	---	---------	------	---	--

### OTHER FIGHTING SHIPS

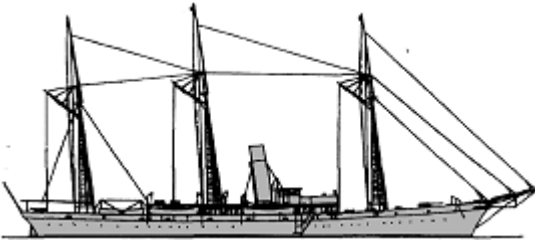

PG	Miranda	1	1	Miranda	1895	No picture	200t, 41.5x5.8x2.5m, 1b,1vte, 315hp, 10kts, 55p; 4x1-57/42
	Mariscal Sucre	1	2	Mariscal Sucre	1887		1030t, 58.6x8.9x3.8m, 2b,2hte, 2627hp, 15.9kts, 92p; 2x1-102/40, 2x1-57/50, 6x1-47/40, 2x1-37/40; 300troops
APG -		2	1	Restaurador	1884		750t; 1x1-76/40
			2	Jose Felix Ribas	1894		300t

© Ivan Gogin, 2015



[home](#)[World navies yesterday](#)[1920](#)

# Yugoslavia 01 January 1920

## TORPEDO SHIPS

TB	T9	4	1	T9	1909		203t, 56.9x5.4x1.4m, 2b,1vte, 3000hp, 26.2kts, 38p; 4x1-47/30, 3x1-450TT
			2	T10	1909		
			3	T11	1909		
			4	T12	1907		
	T1	4	5	T1	1914		320t, 58.2x5.7x1.5m, 2b,2st, 5000hp, 28kts, 52p; 2x1-66/27, 2x2-450TT
			6	T2	1914		
			7	T3	1914		
			8	T4	1914		
	T5	4	9	T5	1915		330t, 58.8x5.8x1.5m, 2b,2st, 5000hp, 28kts, 52p; 2x1-66/27, 2x2-450TT
			10	T6	1916		
			11	T7	1916		
			12	T8	1916		

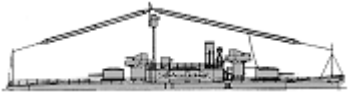
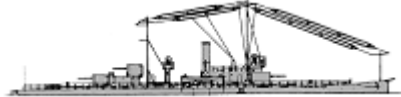
## OTHER FIGHTING SHIPS

RMON	Morava	1	1	Morava	1892		448t, 54.0x9.0x1.2m, 2b,2vte, 1200hp, 10kts, 84p; 50belt, 19deck, 75CT; 2x1-120/31, 2x1-66/37
	Drina	2	2	Drina	1905		470(2)-442(3)t, 60.3(2)-57.7(3)x9.5x1.2m, 2b,2vte, 1400hp, 13kts, 89p; 40belt, 25deck, 40(2)-75(3)CT; 2x1-120/33, 1x1-120/8(3), 2x1-90/42(2), 1x1-66/16(3), 2x1-47/40(2)
			3	Sava	1904		
	Drava	1	4	Drava	1914		540t, 57.9x10.3x1.3m, 2b,2vte, 1500hp, 13kts, 95p; 50belt, 19deck, 75CT; 1x2-120/42, 3x1-120/8, 2x1-66/47
	Soca	2	5	Soca	1915		580t, 62.0x10.3x1.3m, 2b,2vte, 1750hp, 13.5kts, 91p; 40belt, 25deck, 50CT; 1x2-120/42, 2x1-120/8, 2x1-66/24, 2x1-47/40
6			Vardar	1915			
PGR	Bregalnica	2	1	Bregalnica	1916		133t, 44.0x6.0x1.0m, 2b,2gst, 1200hp, 15kts, 40p; 8belt, 6deck, 10turrets, 10CT; 2x2-66/24
			2	Neretva	1916		

