

[home](#)

THE NAVAL BALANCE 1910

Navies of the world

01/01/1910

1. United Kingdom - 1933 tt; 2. USA - 776 tt; 3. Germany - 722 tt; 4. France - 662 tt; 5. Japan - 390 tt; 6. Italy - 330 tt; 7. Russia - 322 tt; 8. Austria-Hungary - 155 tt

tt - thousand ton



[Argentina](#)

[Australia](#)

[Austria-Hungary](#)

[Belgium](#)

[Brazil](#)

[Bulgaria](#)

[Cambodia](#)

[Chile](#)

[China](#)

[Colombia](#)

[Costa Rica](#)

[Cuba](#)

[Denmark](#)

[Dominican Republic](#)

[Ecuador](#)

[Egypt](#)

[El Salvador](#)

[France](#)

[Germany](#)

[Greece](#)

[Haiti](#)

[Honduras](#)

[Italy](#)

[Japan](#)

[Liberia](#)

[Mexico](#)

[Netherlands](#)

[New Zealand](#)

[Norway](#)

[Ottoman Empire](#)

[Paraguay](#)

[Persia](#)

[Peru](#)

[Portugal](#)

[Romania](#)

[Russia](#)

[Sarawak](#)

[Siam](#)

[Spain](#)

[Sweden](#)

[United Kingdom](#)

[United States of America](#)

[Uruguay](#)

[Venezuela](#)

1576474

[Website Hit Counter](#)

© Ivan Gogin, 2015

[home](#)[World navies yesterday](#)[1910](#)

Argentina 01 January 1910

BATTLESHIPS

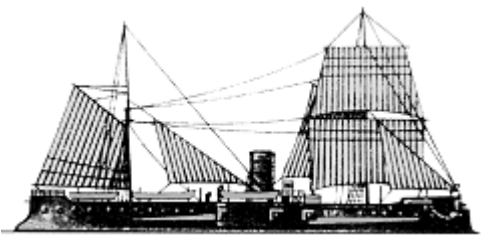
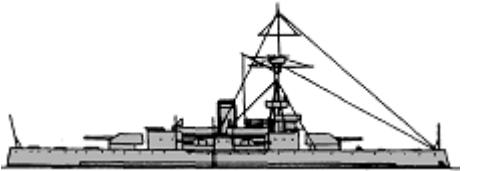



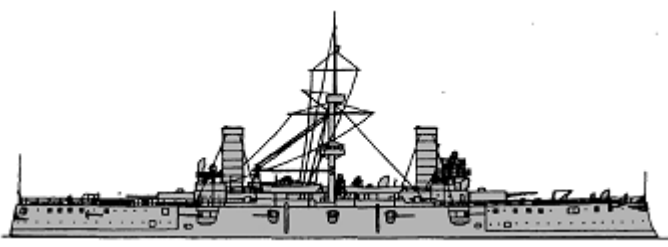
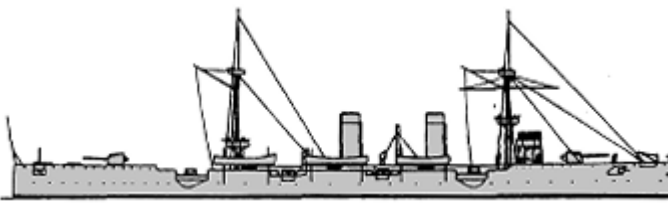

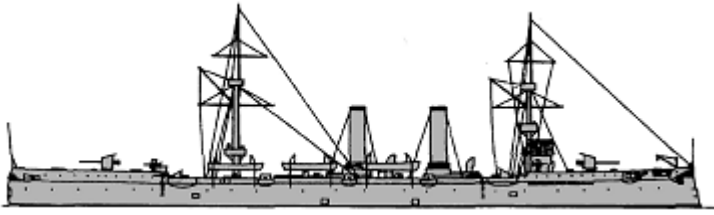
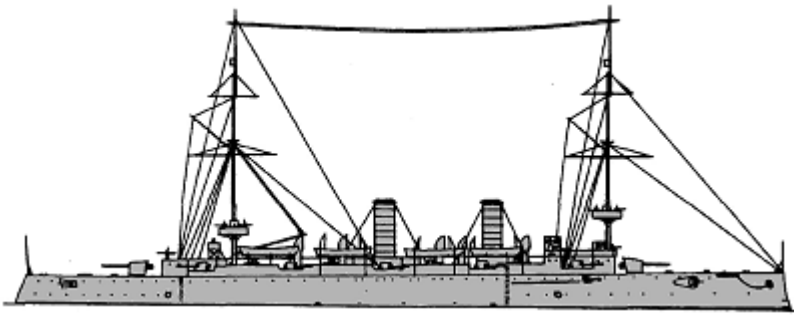
	El Plata	1	El Plata	1875		1500t, 56.7x13.4x3.2m, 4b,2vc, 750hp, 9.5kts, 126p; iron- 152belt, 30deck, 229turret; 1x2-203/30, 2x1-120/40, 2x1-57/40, 4x1-25/42
		2	Los Andes	1875		
BC	Almirante Brown	1	Almirante Brown	1882		4200t, 73.2ppx15.2x6.3m, 8b,2vc, 5400hp, 14kts, 520p; compound- 229belt, 203battery, 203CT; 10x1-150/50, 6x1-120/50, 2x1-47/40, 2-450TT
	Libertad	4	Libertad	1892		2595t, 70.1ppx13.1x4.0m, 4b,2vte, 2780hp, 14.2kts, 230p; steel- 203belt, 37deck, 203barbettes, 102CT; 2x1-238/32, 4x1-120/41, 4x1-47/42, 2-450TT
		5	Independencia	1892		

CRUISERS

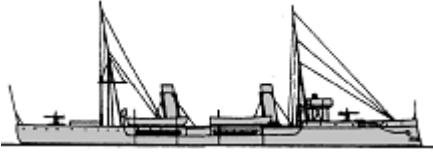
CA	Garibaldi	1	Garibaldi	1896		6775t, 111.7x18.2x7.1m, 8b,2vte(1-3)-16b,2vte(4), 13000hp, 20kts, 500-540p; Harvey(1-3)- 150belt, 150turrets, 37deck, 150CT; 2x1-254/40(1,3,4), 2x2-203/45(2), 10x1-152/40(1,2), 14x1-152/40(3,4), 6x1-120/41(1,2), 2x1-76/40(3,4), 10x1-57/40, 10x1-37/20(1,2), 12x1-37/20(3,4)
		2	San Martin	1898		
		3	General Belgrano	1898		
		4	Pueyrredon	1898		
	Veinticinco de Mayo	1	Veinticinco de Mayo	1891		3500t, 107.9x13.4x4.9m, 4b,2vte, 14050hp, 22.4kts, 320p; steel- 114slopes, 89deck, 51shields, 102CT; 1x1-209/32, 8x1-120/37, 12x1-47/37, (1+2x1)-450TT

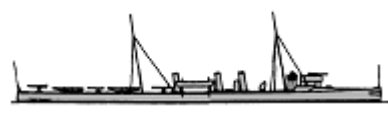
CL	Nueve de Julio	1	2	Nueve de Julio	1893		3600t, 113.5x13.4x5.0m, 8b,2vte, 14500hp, 22.2kts, 327p; steel- 114slopes, 89deck, 51shields, 102CT; 4x1-152/40, 8x1-120/41, 12x1-47/40, 5-450TT
	Buenos Aires	1	3	Buenos Aires	1896		4788t, 129.2x12.9x5.6m, 8b,2vte, 17000hp, 24kts, 350p; steel- 127slopes, 38deck, 114shields, 152CT; 2x1-203/45, 4x1-152/45, 6x1-120/44, 16x1-47/40, 5-450TT

TORPEDO SHIPS

PGT	Espera	1	1	Espera	1890		520t, 64.0x7.6x2.5m, 6b,2vte, 3420hp, 19.4kts, 47p; 2x1-76/46, 5x1-47/42, 1-450TT
	Patria	1	2	Patria	1894		1029t, 76.7x9.6x3.0m, 4b,2vte, 5000hp, 20.5kts, 100p; 2x1-120/41, 4x1-63/42, 2x1-47/42, 5-450TT
DD	Corrientes	3	1	Corrientes	1898		280t, 57.9x5.9x2.2m, 6b,2vte, 4200hp, 27kts, 54p; 1x1-76/46, 3x1-57/42, (1+2x1)-450TT
			2	Entre Rios	1896		
			3	Misiones	1897		
TB	Ferré	4	1-4	Ferré, Enrique Py, Centella, Alerta	1880-1882		52t, 30.5x3.8x1.8m, 1b,1vc, 500hp, 18.5-20kts, 11p; 2x4-25/42, 2-356TT
	Nr.1	2	5, 6	Nr.1, 2	1881	No picture	17t, 18.4x2.3x1.1m, 1b,1vc, 230hp, 16kts, 10p; 1spar torpedo
	Nr.1	8	7-14	Nr.1-8	1890		16t, 18.3x2.8x1.1m, 1b,1vte, 230-250hp, 17-18kts, 10p; 1x1-47/42, 1x1-356TT
	Bouchard	6	15-20	Bouchard, Bathurst, Jorge, King, Pinedo, Thorne	1890-1892		90t, 39.6ppx4.3x1.8m, 2b,2vte(15,17-20)-2b,1vqe(16), 1110(15,17-20)-1230(16)hp, 23.5(15,17-20)-24.4(16)kts, 15p; 2x1-47/42, 1x4-25/42, (1+1x2)-450TT
	Comodoro Py	2	21	Comodoro Py	1892	No picture	110t, 45.7x4.4x1.1m, 2b,1vte, 1800hp, 25kts, 27p; 2x1-47/42, 1x4-25/42, (1+1x2+1x1)-450TT
		22	Comodoro Murature	1892			

OTHER FIGHTING SHIPS

PG	Pilcomayo	2	1	República	1876		420t, 33.5x9.1x2.4m, 2b,2hc, 430hp, 9.7kts, 100p; 1x1-279/14, 2x1-79/25, 2x1-63/42
			2	Constitución	1876		

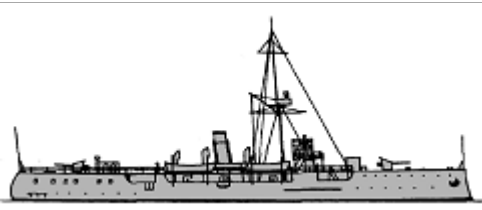
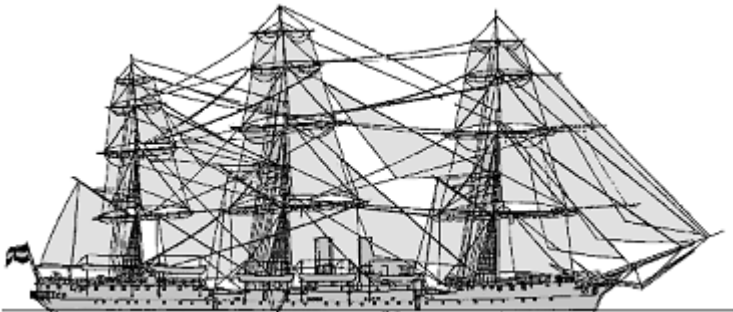
PGR	Rosario	1	Rosario	1909		1055t, 76.4x9.8x2.1m, 2b,2vte, 1300hp, 14.5kts, 145p; 76belt, 25deck, 76CT; 2x1-152/13, 6x1-76/40
		2	Paraná	1909		
CT	Presidente Sarmiento	1	Presidente Sarmiento	1898		2733t, 85.5ppx13.3x5.9m, 4b,2vc, 1800hp, 13kts, 305+40p, 4x1-120/43, 6x1-57/42, 2x1-37/27, 3-356TT

© Ivan Gogin, 2015

[home](#)[World navies yesterday](#)[1910](#)

Australia 01 January 1910

TORPEDO SHIPS

TB	Childers	1	1	Childers	1884	No picture	61t, 35.5x3.8x1.7m, 1b,1hce, 679hp, 18kts, 18p; 2x1-37/30, 2-381TT
	Countess of Hopetown	1	2	Countess of Hopetown	1890		82t, 36.6x4.1xm, 1b,1vte, 1150hp, 23kts, 19p; 3x1-47/40, (2+1x1)-356TT
TB2cl	Gordon	1	1	Gordon	1886	No picture	12t, 17.1x2.9x1.5m, 1b,1csce, 150hp, 15kts, 11p; 3x1-25/40, 2-356TC
	Midge	1	2	Midge	1888	No picture	12t, 17.2x2.8x1.4m, 1b,1hce, hp, kts, p; 2x2-25/40, 1spar torpedo
	Defender	4	3 - 6	Nepean, Lonsdale, No191, Mosquito	1883 - 1884	No picture	12t, 19.2ppx2.3x1.2m, 1b,1hce, 17kts, 7p; 1x2-25/40, 1-356TT

OTHER FIGHTING SHIPS

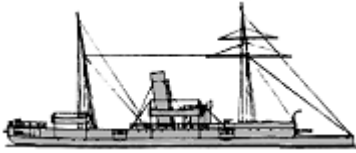
PG	Protector	1	1	Protector	1884		920t, 57.3x9.1x3.8m, 4b,2vce, 1500hp, 14kts, 90p; 1x1-203/26, 5x1-152/31, 4x1-47/40, 5x1-11.4
	Paluma	2	2	Paluma	1884	No picture	360t, 36.6x7.9x2.9m, 1b,2vce, 400hp, 10.5kts, p; 1x1-203/26(54), 1x1-152/31, 2x1-37/30, 2x1-11.4
			3	Gayundah	1884		

Google
Custom Search

© Ivan Gogin, 2014

[home](#)[World navies yesterday](#)[1910](#)

Austria-Hungary 01 January 1910

BATTLESHIPS

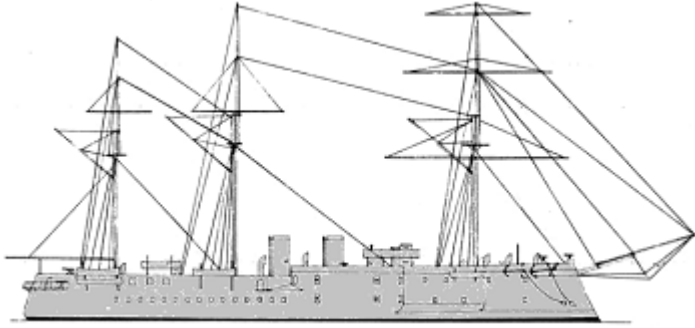
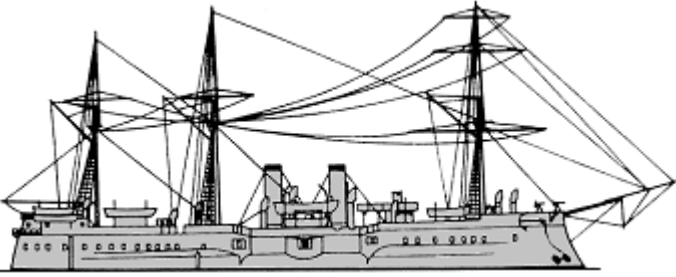
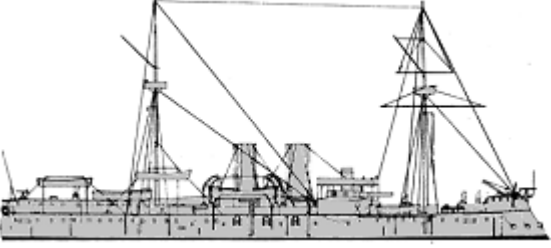
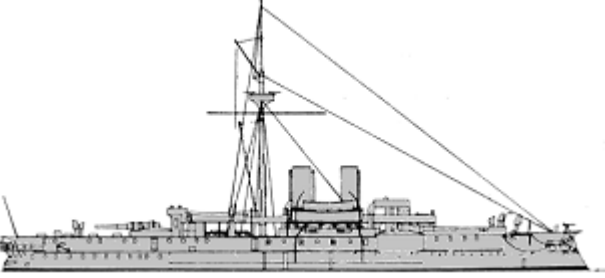
						7731t, 95.0x17.7x7.9m, 8b,1hrccr, 4158hp, 13.7kts, 548p; iron- 230belt, 175casemates; 8x1-263/20, 6x1-87/22, 2x1-66/16, 4x1-47/30, 5x5-47/22, 2x5-25/41, 4-356TT
						7431t, 89.4x21.8x7.6m, 8b,2vte, 8160hp, 15.3kts, 575p; iron- 370belt, 40deck, 370casemates, 175CT; 6x1-235/32, 5x1-149/33, 2x1-66/16, 9x1-47/40, 6x1-47/30, 2-356TT
						5075t, 87.2x17.1x6.6m, 10b,2vc, 8000hp, 17kts, 430p; compound- 230belt, 25deck, 280turrets, 50CT; 2x1-305/32, 6x1-149/33, 2x1-66/16, 7x1-47/40, 2x1-47/30, 2x1-37/20, 4-400TT
BB						6829t, 97.6x19.3x7.4m, 10b,2vc, 6000hp, 15.5kts, 447p; Harvey- 305belt, 70deck, 250turrets, 75CT; 3x1-305/32, 6x1-120/31, 2x1-66/16, 5x1-47/40, 2x1-47/30, 2x1-37/20, 4-400TT
		5	Monarch	1898		
		6	Wien	1898		

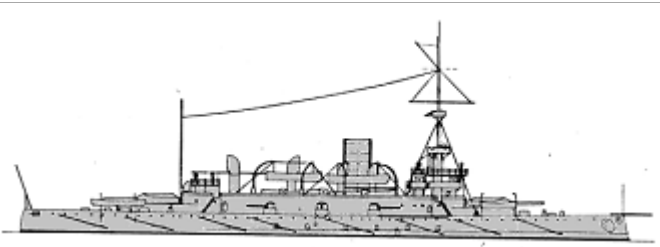
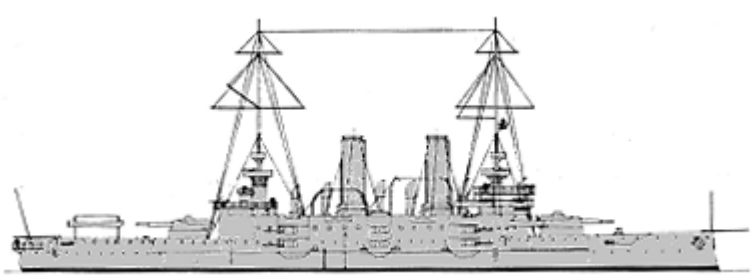
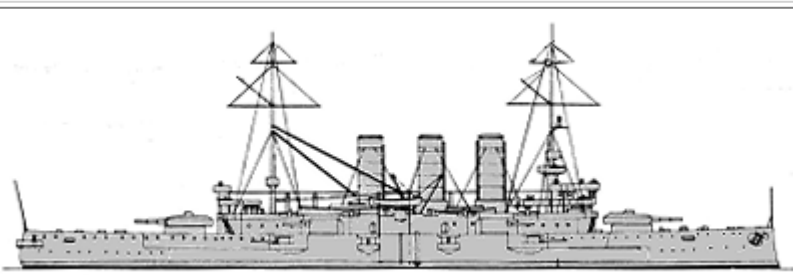
		3	7	Monarch	1898		5645(5,7)-5636(6)t, 99.2x17.0x6.4m, 7b,2vte(5,6)-16b,2vte(7), 8500hp, 17.5kts, 426p; NS- 270belt, 40deck, 250turrets, 250CT; 2x2-238/37, 6x1-149/37, 2x1-66/16, 10x1-47/40, 4x1-47/30, 2-450TT
			9	Habsburg	1902		8823(9,11)-8748(10)t, 114.6x19.9x7.5m, 16b,2vte, 15000hp, 19.5kts, 638p; 220belt, 40deck, 280turrets, 200CT; (1x2+1x1)-238/37, 12x1-149/37, 10x1-66/42, 6x1-47/40, 2x1-47/30, 2-450TT
10	Árpád	1903					
11	Babenberg	1904					
Erzherzog Karl	3	12	Erzherzog Karl	1906		10472t, 126.2x21.8x7.5m, 18b,2vte, 18000hp, 20.5kts, 638p; 210belt, 55deck, 240turrets, 220CT; 2x2-238/37, 12x1-190/40, 12x1-66/42, 4x1-47/40, 2x1-47/30, 4x1-37/42, 2-450TT	
		13	Erzherzog Friedrich	1907			
		14	Erzherzog Ferdinand Max	1907			



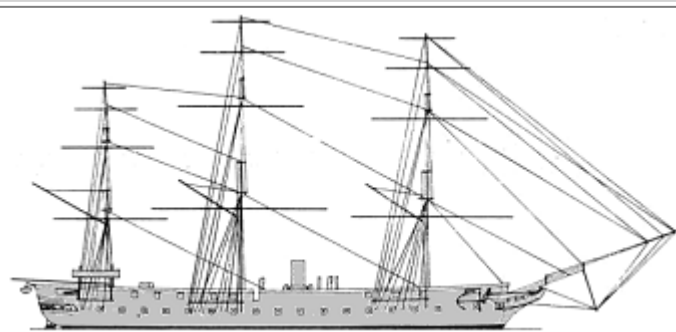
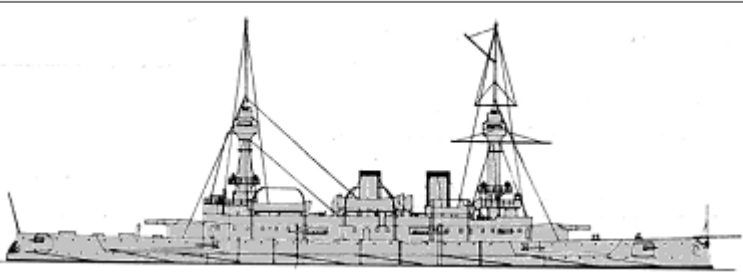

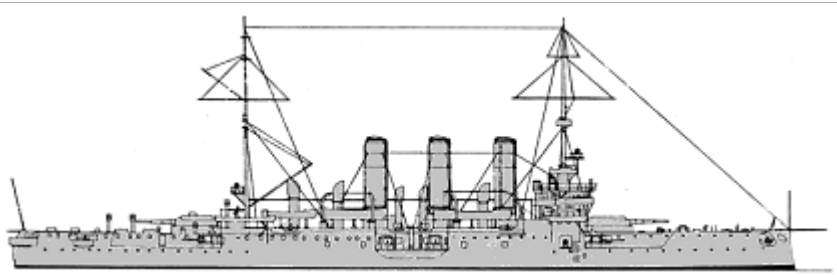
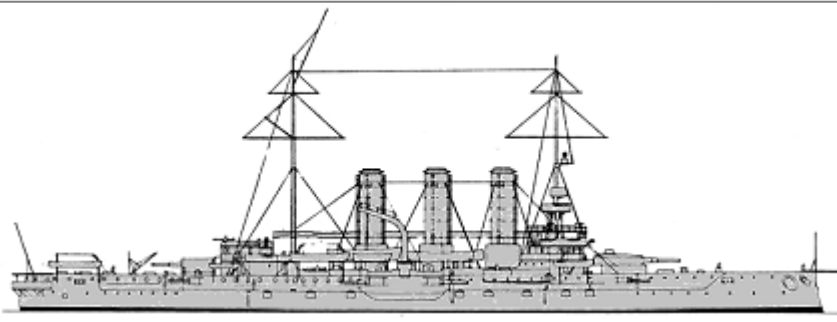
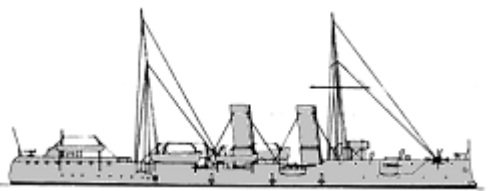
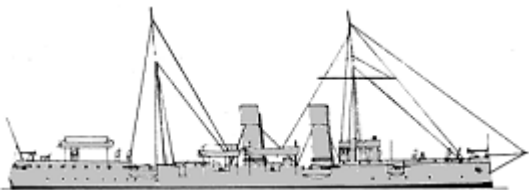
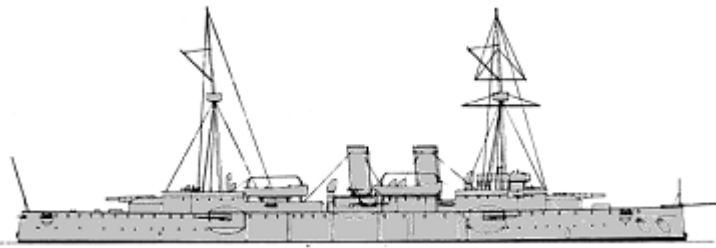
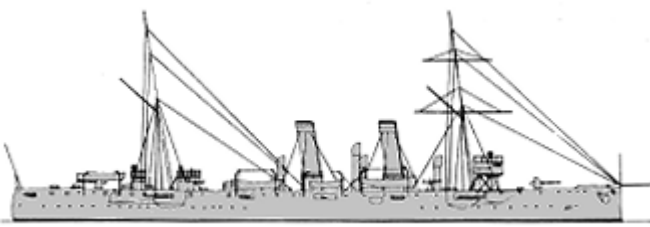
CRUISERS





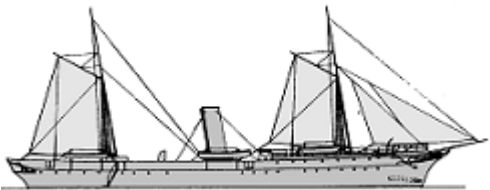
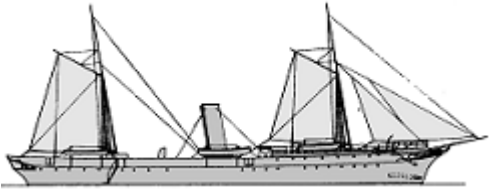
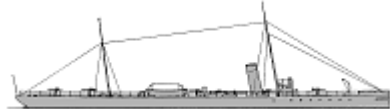
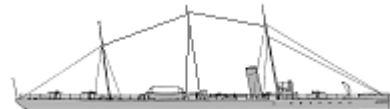

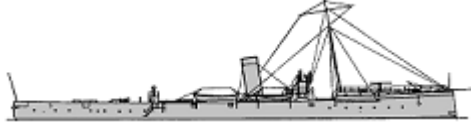
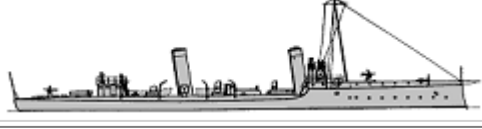

CA		1	1	Radetzky	1873		3956t, 79.1x14.3x7.0m, 4b,1hse, 3385hp, 13.4kts, 450p; 15x1-149/24, 2x1-66/16, 4x1-47/30, 3x5-47/22, 3-356TT	
			1	2	Kaiserin und Königin Maria Theresia	1894		6026t, 113.7x16.3x6.8m, 10b,2hte, 9000hp, 19kts, 475p; Harvey- 100belt, 60deck, 100turrets, 50CT; 2x1-238/32, 8x1-149/33, 2x1-66/16, 12x1-47/40, 6x1-47/30, 4-450TT
			1	3	Kaiser Karl VI	1900	6864t, 119.0x17.3x6.8m, 18b,2vte, 12000hp, 20.8kts, 535p; Harvey- 220belt, 60deck, 200turrets, 200CT; 2x1-238/37, 8x1-149/37, 2x1-66/16, 16x1-47/40, 2x1-47/30, 2-450TT	

							
	Sankt Georg	1 4	Sankt Georg	1905		8070t, 124.3x19.0x6.8m, 12b,2vte, 15000hp, 22kts, 535p; 210belt, 50deck, 210turrets, 200CT; 1x2-238/37, 5x1-190/40, 4x1-149/37, 2x1-66/16, 6x1-47/40, 2x1-47/30, 2-450TT	
CL	Panther	1	Panther	1885		1557t, 73.2x10.4x4.3m, 6b,2vc, 5940(1)-6380(2)hp, 18.4(1)-18.7(2)kts, 186p; steel- 12deck; 2x1-120/31(2), 4x1-66/40(1), 4x1-47/40(2), 6x5-47/22(2), 4-356TT(2)	
		2	Leopard	1886			
	Tiger	1 3	Lacroma	1888		1657t, 76.0x10.6x4.3m, 6b,2vc, 5700hp, 18.6kts, 188p; steel- 12deck; 6x1-47/40	
	Kaiser Franz Joseph I	4	Kaiser Franz Joseph I	1890		4494t, 103.7x14.8x5.7m, 10b,2hte, 8450hp, 19kts, 367p; steel- 57hull, 38deck, 90barbettes, 50CT; 2x1-149/37, 6x1-149/33, 2x1-66/16, 12x1-47/40, 2x1-47/30, 4-400TT	
		5	Kaiserin Elisabeth	1892			
	Zenta	3	6	Zenta	1899		2503(6)-2625(7)-2562(8)t, 96.9x11.7x4.2m, 8b,2vte, 8160hp, 20.8kts, 308p; steel- 50slopes, 40deck, 35casemates, 50CT; 8x1-120/37, 8x1-47/40, 2x1-47/30, 2-450TT
			7	Aspern	1900		
8			Szigetvár	1901			

TORPEDO SHIPS

		1	Zara	1881		
	Zara	2				852t, 67.2x8.2x3.7m, 5b,2vc, 2600hp, 14.3kts, 148p; 4x1-87/22, 1x1-66/16, 4x1-47/30, 1x5-

			2	Spalato	1880		47/22, 2x5-25/41, (2+1x1)-356TT
	Sebenico	1	3	Sebenico	1882		890t, 69.7x8.2x3.4m, 4b,2vc, 1344hp, 12.8kts, 135p; 2x1-120/37, 1x1-66/16, 4x1-47/40, 4x1-47/30, 4x1-37/20
	Blitz	2	4	Blitz	1888		426t, 59.0ppx6.9x2.1m, 2b,1vte, 2600hp, 21kts, 61p; 8x1-47/40, (1+1x1)-450TT(5), (1+1x1)-356TT(4)
			5	Komet	1889		
PGT	Meteor	1	6	Meteor	1889		436t, 57.0ppx6.8x2.6m, 2b,1vte, 2600hp, 21kts, 60p; 9x1-47/30, (1+1x1)-450TT
	Planet	1	7	Planet	1890		525t, 67.1x7.0x2.8m, 4b,2vte, 3500hp, 19.6kts, 84p; 2x1-66/37, 8x1-47/40, (1+1x1)-450TT
	Trabant	1	8	Trabant	1890		540t, 67.0x8.0x2.4m, 4b,2vte, 3800hp, 20.1kts, 84p; 2x1-66/37, 8x1-47/40, (1+1x1)-450TT
	Satellit	1	9	Satellit	1893		616t, 68.9x8.1x2.4m, 4b,2vte, 4000hp, 23kts, 86p; 1x1-66/37, 6x1-47/40, (1+1x1)-450TT
	Magnet	1	10	Magnet	1896		510t, 67.5ppx8.2x3.3m, 4b,2vte, 6000hp, 26kts, 80p; 6x1-47/40, 2x1-450TT
DD	Huszár	11	1	Ulan	1906		414t, 68.4x6.3x1.9m, 4b,2vte, 6000hp, 28kts, 70p; 1x1-66/42, 7x1-47/40, 2x1-450TT
			2	Streiter	1906		
			3	Wildfang	1907		
			4	Scharfschütze	1907		
			5	Uskoke	1907		
			6	Turul	1908		
			7	Pandur	1909		
			8	Csikós	1909		
			9	Reka	1909		
			10	Dinara	1909		
			11	Velebit	1909		

Adler	2	1	Adler	1886		100t, 41.2x4.2x1.7m, 2b,1vc, 1300hp, 22kts, 16p; 2x1-37/20, 2-356TT
		2	Falke	1886		
Sperber	2	3,	Sperber, Habicht	1886		93t, 39.9x4.8x1.9m, 2b,1vte, 970hp, 18.5kts, 16p; 2x1-37/20, 2-356TT
		4				
Bussard	20	5-24	Bussard, Condor, Geier, Uhu, Würger, Kranich, Reiher, Ibis, Rabe, Elster, Kukuk, Staar, Krähe, Flamingo, Sekretär, Weihe, Marabu, Gaukler, Harpie, Kibitz	1886-1891		88t, 39.9x4.8x1.9m, 1b,1vte, 1000hp, 19kts, 16p; 2x1-37/20, (1+1x1)-356TT
XXXIII	1	25	XXXIII	1887		70t, 36.8x4.5x1.9m, 1b,1vc, 700hp, 17kts, 16p; 2x1-37/20, 2-356TT
XXXIV	6	26-31	XXXIV-XXXIX	1889-1891		64t, 36.9x4.8x1.9m, 1b,1vc, 750hp, 20.3kts, 16p; 2x1-37/20, 1-356TT
Natter	1	32	Natter	1896		166t, 47.3x5.3x2.8m, 2b,1vte, 2200hp, 24kts, 21p; 2x1-47/30, 3x1-450TT
Viper	1	33	Viper	1896		124t, 45.0x4.5x2.3m, 2b,1vte, 1900hp, 25kts, 21p; 2x1-47/30, 3x1-450TT
Boa	4	34	Boa	1898		132t, 46.6x4.7x2.3m, 2b,1vte, 2000hp, 24.5kts, 21p; 2x1-47/30, 3x1-450TT
		35	Cobra	1898		
		36	Python	1899		
		37	Kigyo	1900		
Kaiman	20	38	Kaiman	1905		211t, 56.0x5.5x1.3m, 2b,1vte, 3000hp, 26kts, 31p; 4x1-47/30, 3x1-450TT
		39	Anaconda	1906		
		40	Alligator	1906		
		41	Krokodil	1906		
		42	Wal	1907		
		43	Seehund	1907		
		44	Delphin	1907		
		45	Narwal	1908		
		46	Hai	1908		
		47	Möwe	1908		
		48	Schwalbe	1909		
		49	Pinguin	1909		
		50	Drache	1909		
		51	Greif	1909		
52	Triton	1908				
53	Hydra	1909				
54	Skorpion	1909				
55	Phönix	1909				
56	Krake	1909				
57	Polyp	1909				
		58	Tb.I	1909		

TB

Tb.I	4	59	Tb.II	1909		116t, 44.2x4.4x1.5m, 2b,1vte, 2500hp, 28kts, 20p; 2x1-47/40, 2x1-450TT
		60	Tb.III	1909		
		61	Tb.IV	1909		



SUBMARINES

SS	U1	2	1	U1	1909		230/270t, 30.5x3.4x3.2m, 2pe/em, 640/200hp, 10.3/5kts, 17p, 30m; 3-450TT
			2	U2	1909		
	U3	2	3	U3	1909		
			4	U4	1909		

ESCORTS

AY	-	2	1	Dalmat	1896	260t
			2	Taurus	1904	1300t, 67.0x6.9m, 2000hp, 15kts; 4x1-47/30

OTHER FIGHTING SHIPS

PG	Albatros	2	1	Albatros	1874	No picture	570t, 46.0x8.3x3.4m, 400hp, 10kts, 99p; 2x1-149/24, 1x1-83/17
			2	Nautilus	1874		
RMON	Leitha	2	1	Leitha	1872		315t, 50.6x8.1x1.1m, 2b,2vte, 700hp, 8kts, 59p; steel- 44side, 25deck, 50CT; 1x1-120/33, 2x1-47/40
			2	Maros	1872		
	Körös	2	3	Körös	1892		448t, 54.0x9.0x1.2m, 2b,2vte, 1200hp, 10kts, 72p; 50side, 19deck, 75(3)-50(4)CT; 2x1-120/31, 2x1-66/37
			4	Szamos	1892		
	Temes	2	5	Temes	1904		486t, 57.7x9.5x1.2m, 2b,2vte, 1400hp, 13kts, 86-89p; 40side, 25deck, 75CT; 2x1-120/33, 1x1-120/8, 1x1-66/16
			6	Bodrog	1904		

COASTAL FORCES

YPR	A	1	1	A	1895	No picture	33t, 22.0x3.5x1.1m, 200hp
	B	1	2	B	1906	No picture	37t, 28.0x4.4x0.7m, 4pe, 400hp, 14kts, 14p
	E	2	3, 4	E, F	1908	No picture	15t, 18.3x2.7x0.8m, 3pe, 350hp, 22kts, 7p
	C	2	5, 6	C, D	1909	No picture	39t, 30.0x4.3x0.7m, 2pe, 600hp, 14kts, 12p

MINE WARFARE SHIPS

ML	Dromedar	1	1	Dromedar	1891	No picture	175t, 32.0x5.4x1.9m, 1b,1vte, 350hp, 10kts, 25p; 2x1-47/30, 50mines
	Salamander	1	2	Salamander	1892	No picture	286t, 39.6x8.1x1.5m, 1b,1vte, 350hp, 10kts, 28p; 2x1-47/30, 90mines
	Basilisk	1	3	Basilisk	1903	No picture	314t, 46.0x7.9x1.5m, 1b,1vte, 550hp, 11kts, 40p; 2x1-47/40, 145mines
MS	MT.VIII	10	1-10	MT.VIII-XVII	1909	No picture	47t, 18.0x4.3x1.3m, 1b,1vte, 170hp, 10kts, 12p; 1x1-47/40, mines, sweeps



© Ivan Gogin, 2014

[home](#)

[World navies yesterday](#)

[1910](#)

Belgium 01 January 1910

ESCORTS

FPV	Ville d'Anvers	1	1	Ville d'Anvers	1886	No picture	684t, 65.2x9.1x3.6m, 45p
-----	----------------	---	---	----------------	------	------------	--------------------------

© Ivan Gogin, 2015



[home](#)[World navies yesterday](#)[1910](#)

Brazil 01 January 1910

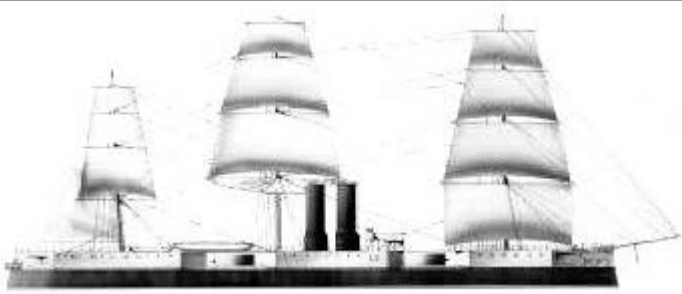
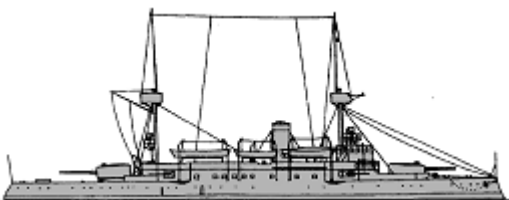
BATTLESHIPS



BB	Riachuelo	1	1	Riachuelo	1883		6100t, 93.0ppx15.9x6.0m, 10b,2vc, 7300hp, 16.7kts, 367p; compound- 292belt, 254turrets, 254CT; 2x2-234/31, 6x1-120/32, 6x1-47/40, 5-356TT
BC	Marshal Deodoro	1		Marshal Deodoro	1900		3162t, 81.5x14.4x4.2m, 8b,2vte, 3400hp, 15kts, 200p; Harvey- 350belt, 45deck, 220turrets, 125CT; 2x1-234/45, 4x1-120/50, 6x1-57/40, 2-450TT
		2		Marshal Floriano	1901		

CRUISERS

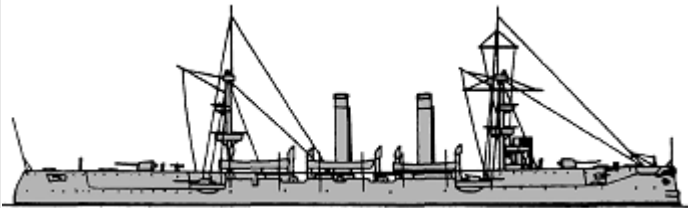
CL	Almirante Tamandaré	1	1	Almirante Tamandaré	1893		4735t, 89.7x14.4x6.0m, 7b,2hte, 7500hp, 17kts, 400p; steel- 40deck, 76casemates, 51CT; 10x1-152/40, 2x1-120/40, 10x1-47/40
	Benjamin Constant	1	2	Benjamin Constant	1894		2820t, 74.0x13.6x5.6m, 2vte, 4000hp, 15kts, 216+184p; 51deck, 95CT; 4x1-152/40, 8x1-120/40, 2x1-76/40, 2x1-37/20, 2x5-37/17, 4-450TT

	República	1	3	República	1894		1300t, 64.0ppx10.7x3.9m, 2hte, 3800hp, 17.4kts, 160p; steel- 51slopes, 25deck; 6x1-120/40, 4x1-57/40, (1+2x1)-356TT
	Almirante Barroso	1	4	Almirante Barroso	1897		3437t, 108.0x13.3x5.2m, 4b,2vte, 7500hp, 20.2kts, 366p; 88slopes, 31deck, 102CT; 6x1-152/50, 4x1-120/50, 10x1-57/40, 4x1-37/20, 3-450TT

TORPEDO SHIPS

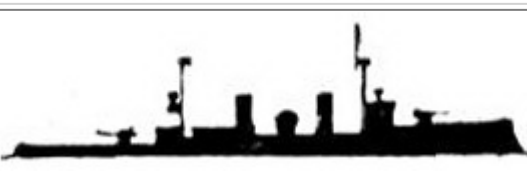
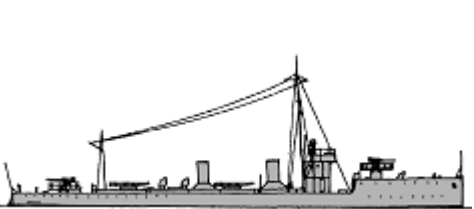
PGT	Tiradentes	1	1	Tiradentes	1893		795t, 50.3ppx9.1x3.3m, 2vte, 1646hp, 14.5kts, 110p; steel- 25CT; 4x1-120/40, 3x1-57/40, 2x1-356TT
	Gustavo Sampaio	1	2	Gustavo Sampaio	1893		480t, 60.0ppx6.1x2.6m, 2vte, 2000hp, 18kts, 60p; steel- 19CT; 2x1-89/40, 4x1-47/40, (1+2x1)-356TT
	Tupi	2	3	Tupi	1897		1014t, 76.1x9.4x3.1m, 2vte, 7000hp, 22.5kts, 110p; steel- 13deck, 114shields, 25CT; 2x1-120/37, 6x1-57/37, 2x1-37/37, (1+2x1)-356TT
			4	Timbira	1897		
	Tamoio	1	5	Tamoio	1900		1063t, 82.0x8.8x3.0m, 2vte, 6500hp, 23kts, 110p; steel- 13deck, 114shields, 25CT; 2x1-120/37, 6x1-57/37, 2x1-37/37, (1+2x1)-356TT
DD	Pará	6	1	Amazonas	1909		560t, 73.2ppx7.2x2.4m, 2b,2vte, 8000hp, 27kts, 130p; 2x1-102/40, 4x1-47/40, 2x1-450TT
			2	Pará	1909		
			3	Piauí	1909		
			4	Rio Grande do Norte	1909		
			5	Paraíba	1909		
			6	Mato Grosso	1909		
	Núm.1	5	1-5	Núm.1-5	1882	No picture	40(1)-52(2-5)t, 30.5(1)-33.5(2-5)x3.8x1.7m, 1b,1vc, 500hp, 20(1)-20.4(2-5)kts; 1x1-37/20, 2-356TT
	Araguari	3	6	Araguari	1893	No picture	110t, 45.7x4.4x1.1m, 2b,1vte, 1800hp, 25kts, 27p; 2x1-47/42, (1+2x1)-381TT
7			Marcílio Dias	1893			
8			Iguatemi	1893			
			9	Panne	1892		

TB	Panne	5	10	Pedro Affonso	1892		130t, 46.3x5.3x2.4m, 2b,2vte, 2200hp, 26kts, 24p; 2x1-37/37, (1+2x1)-356TT
			11	Pedro Ivo	1892		
			12	Pernambuco	1892		
			13	Silvado	1892		
	Goiás	1	14	Goiás	1907		

OTHER FIGHTING SHIPS



PGR	Yutohy	2	1, 2	Yutohy, Teffé	1892	No picture	33t, 27.4ppx4.6x1.5m, 11kts; 1x1-47/40
	Acre	4	3	Acre	1906	No picture	200t, 36.6x6.1x0.6m, 1b,1vte, 300hp, 11kts, 30p; 1x1-87/13, 1x1-57/42
			4	Amapá	1906		
			5	Juruá	1906		
			6	Missões	1906		
APGR	-	1	1	Oyapock	1908		295t

© Ivan Gogin, 2015

[home](#)[World navies yesterday](#)[1910](#)

Bulgaria 01 January 1910

TORPEDO SHIPS

PGT	Nadezhda	1	1	Nadezhda	1898		715t, 67.0x8.3x3.1m, 4b,2vte, 2600hp, 18kts, 97p; 2x1-100/45, 2x1-65/50, 2x1-47/40, 2x1-381TT
TB	Vasil Levski	2	1, 2	Vasil Levski, Khristo Botev	1877-1878		20t, 18.3x2.3x1.1m, 1b,1vc, 220hp, 13kts, 9p
	Druzki	6	3	Druzki	1908		100t, 38.0x4.4x1.3m, 2b,1vte, 1950hp, 26kts, 32p; 2x1-47/50, (1+1x2)-450TT
			4	Smeli	1908		
			5	Khrabri	1908		
			6	Strogi	1909		
			7	Letyashchi	1909		
			8	Shumni	1909		

© Ivan Gogin, 2015

[home](#)

[World navies yesterday](#)

[1910](#)

Cambodia 01 January 1910

OTHER FIGHTING SHIPS

PG	Lutin	1	1	Lutin	1877		492t, 44.1x7.3x3.3m, 2b,1hc, 440hp, 11kts, 76p; 2x1-139/21, 2x1-90/36, 4x5-37/17
----	-------	---	---	-------	------	---	--

© Ivan Gogin, 2015

[home](#)[World navies yesterday](#)[1910](#)

Chile 01 January 1910

BATTLESHIPS

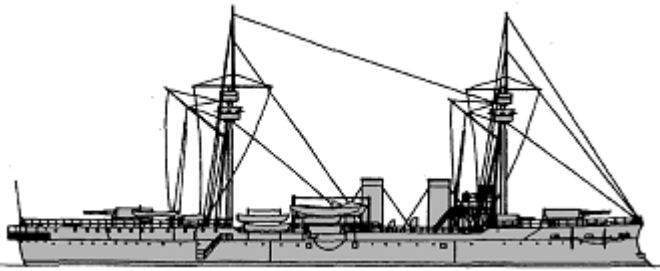
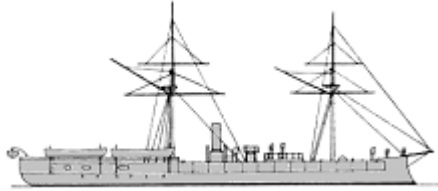

BB	Capitán Prat	1	1	Capitán Prat	1893		6901t, 100.0ppx18.5x7.0m, 5b,2hte, 12000hp, 18.3kts, 480p; steel- 300belt, 50deck, 275barbettes, 265CT; 4x1-240/36, 4x2-120/45, 6x1-57/40, 4x1-47/40, 10x1-37/20, 4-450TT
MON	Huascár	1	1	Huascár	1866		2030t, 57.9ppx10.7x5.6m, 4b,1hse, 1650hp, 12.3kts, 170p; iron- 114belt, 203turret, 76CT; 1x2-203/26, 2x1-57/40, 2x5-37/17

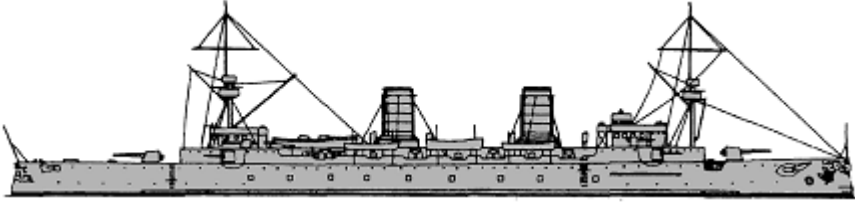
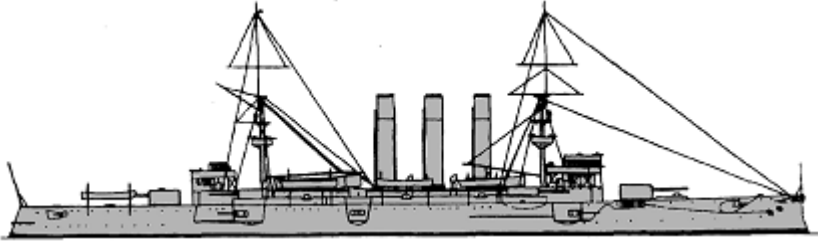
CRUISERS

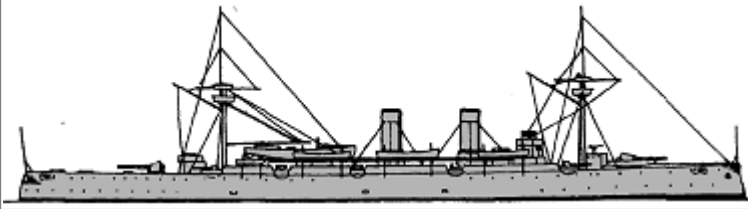
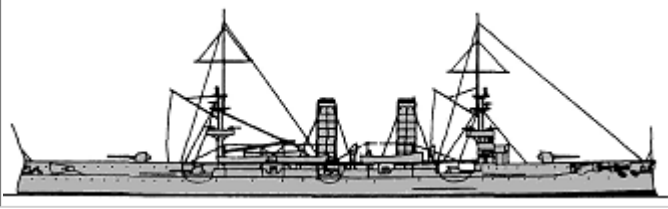
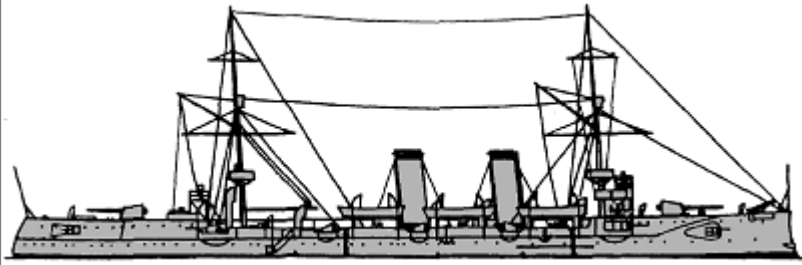
CA	Esmeralda	1	1	Esmeralda	1896		7000t, 132.9ppx16.2x6.2m, 12b,2vte, 16000hp, 22.2kts, 500p; Harvey- 152belt, 51deck, 114shields, 203CT; 2x1-203/40, 16x1-152/40, 8x1-76/40, 3-450TT
	O'Higgins	1	2	O'Higgins	1898		8500t, 135.2x19.1x6.7m, 30b,2vte, 16000hp, 21kts, 500p; Harvey- 178belt, 51deck, 178turrets, 229CT; 4x1-203/40, 10x1-152/40, 4x1-120/44, 10x1-76/40, 10x1-57/40, 3-450TT
	Presidente Errázuriz	2	2	Presidente Errázuriz	1892		2047t, 81.8ppx10.9x4.4m, 4b,2hte, 5400hp, 18.3kts, 170p; steel- 60slopes, 35deck, 90shields, 50CT; 4x1-152/45(1), 4x1-150/36(2), 2x1-120/45(1), 2x1-120/36(2), 4x1-57/40, 3-356TT
				Presidente Pinto	1892		

CL						
	Blanco Encalada	1 3	Blanco Encalada	1894		4568t, 112.8ppx14.2x5.6m, 8b,2vte, 14600hp, 22.8kts, 427p; steel- 102slopes, 44deck, 152shields, 152CT; 2x1-203/40, 10x1-152/40, 12x1-76/40, 12x1-37/20, 5-450TT
	Ministro Zenteno	1 4	Ministro Zenteno	1898		3437t, 100.6ppx13.3x5.1m, 8b,2vte, 7500hp, 20.2kts, 317p; steel- 89slopes, 32deck, 102CT; 8x1-152/45, 10x1-57/40, 4x1-37/20, 3-450TT
	Chacabuco	1 5	Chacabuco	1902		4877t, 127.5x14.2x5.2m, 8b,2vte, 15700hp, 23kts, 400p; Harvey- 114slopes, 44deck, 114shields, 76CT; 2x1-203/45, 10x1-120/40, 12x1-76/40, 6x1-47/40, 3-450TT

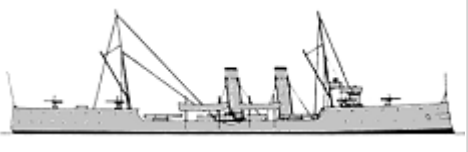
TORPEDO SHIPS

PGT	Almirante Lynch	1	Almirante Lynch	1890		713t, 70.1ppx8.4x2.5m, 4b,2vte, 4275-4532hp, 20.3-20.6kts, 87p; steel- 25deck; 6x1-57/50, (1+4x1)-356TT
		2	Almirante Condell	1890		
DD	Capitán Orella	1	Capitán Orella	1896		300t, 64.9ppx6.6x1.8m, 4b,2vte, 6250hp, 30kts, 65p; 1x1-76/40, 5x1-57/40, 2x1-450TT
		2	Capitán Muñoz Gamero	1896		
		3	Teniente Serrano	1896		
		4	Guardiamarina Riquelme	1896		
	Capitán Merino Jarpa	5	Capitán Merino Jarpa	1902		321t, 65.5ppx6.5x1.8m, 4b,2vte, 6250hp, 30kts, 65p; 1x1-76/40, 5x1-57/40, 2x1-450TT
		6	Capitán O'Brien	1902		
		7	Capitán Thomson	1902		
TB	Sargente Aldea	1	Sargente Aldea	1886	No picture	80t, 38.1x4.0x2.1m, 1b,1vc, 700hp, 20kts, 16p; 2x2-25/42, 2-356TT
		2	Cirujano Videla	1896		
		3	Ingeniero Mery	1896		
		4	Ingeniero Hyatt	1896		

Ingeniero Hyatt	6	5	Teniente Rodriguez	1896		140t, 46.5x4.7x2.4m, 2b,1vte, 2200hp, 27kts, 16p; 3x1-47/40, (1+1x2)-356TT
		6	Ingeniero Mutilla	1898		
		7	Guardiamarina Contreras	1898		

ESCORTS



PC	Yelcho	1	1	Yelcho	1908	No picture	467t, 39.0x7.0x2.9m, 1vte, 350hp, 12kts; 1x1-37/20
----	--------	---	---	--------	------	------------	--

© Ivan Gogin, 2015

[home](#)[World navies yesterday](#)[1910](#)

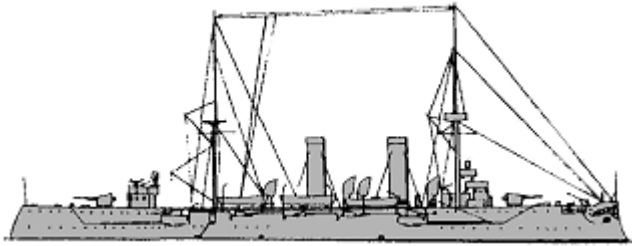
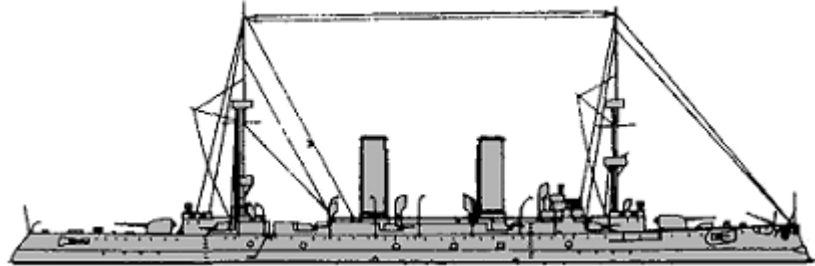
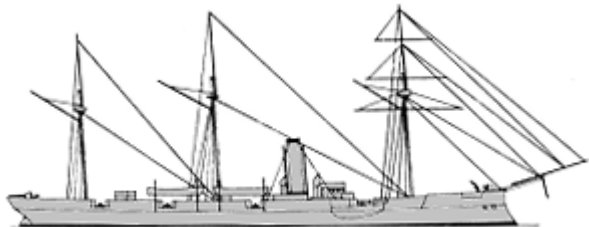

China 01 January 1910

CRUISERS

CL	Hai Yung	1	Hai Yung	1898		2950t, 100.0x12.4x5.8m, 8b,2vte, 7500hp, 19.5kts, 244p; 70slopes, 32deck, 51shields, 37CT; 3x1-149/37, 8x1-105/37, 6x1-47/37, 3-356TT
		2	Hai Chou	1898		
		3	Hai Chen	1898		
	Hai Chi	1	Hai Chi	1899		4515t, 129.2x14.2x5.5m, 12b,4vte, 17000hp, 24kts, 350p; Harvey- 127slopes, 37deck, 114turrets, 152CT; 2x1-203/45, 10x1-120/45, 16x1-47/40, 5-450TT
CLL	Kai Che	1	King Ch'ing	1886		2100t, 76.2x11.0x5.5m, 8b,1hte, 2400hp, 16kts, 300p; steel- casemates; 3x1-178/26, 7x1-121/22, 2-356TT
	Nan Thin	2	Nan Thin	1884		2200t, 84.0x11.0x5.5m, 8b,1hc, 2400hp, 15kts, 250p; 2x1-209/20, 8x1-120/32, 10x4-25/42, 1-356TT
		3	Nan Shui	1884		
	Tung Chi	1	Tung Chi	1896		1900t, 77.0ppx10.4x4.9m, 4b,1vc, 1600hp, 11.6kts, 335p; 2x1-152/40, 5x1-120/45, 3x1-57/40, 8x1-37/20

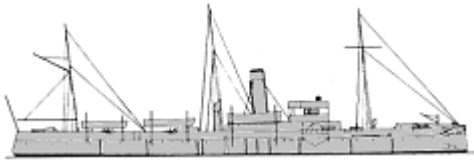
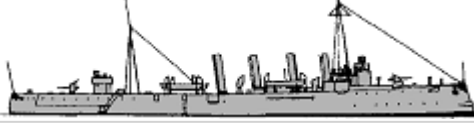
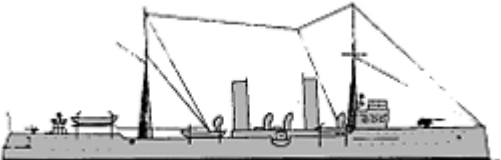

							
	Fu An	1	5	Fu An	1897		1700t, 76.8ppx11.6x5.5m, 4b,1vc, 1600hp, 10kts, 105p; 2x1-57/40

TORPEDO SHIPS

PGT	Kuang Ping	1	1	Fu Ch'ing	1894		1000t, 71.6x8.2x4.0m, 3b,2hte, 2400hp, 16kts, 120p; steel- 25deck, 51CT; 3x1-120/32, 4x1-47/40, (2+2x1)-356TT
	Fei Ying	1	2	Fei Ying	1896		850t, 75.0x8.6x4.0m, 8b,2vte, 5430hp, 22kts, 90p; 25deck, 50shields; 2x1-105/37, 6x1-57/40, 4x1-37/20, (1+2x1)-356TT
	Chien Wei	2	3	Chien Wei	1903		900t, 79.2x8.1x3.5m, 4b,2vte, 6500hp, 20.5kts, 140p; steel- 25belt, 25deck; 1x1-100/44, 3x1-65/50, 6x1-37/27, 2x1-356TT
4			Chien An	1903			
TB	Lei Fu	2	1, 2	Lei Fu, Lei Lung	1884	No picture	64t, 35.0x4.0x1.7m, 2b,1vte, 700hp, 19.8kts, 20p; 2x5-37/17, 2-356TT
	Lei Chen	9	3-11	Lei Chen, Lei Chung, Lei Kong, Lei Kwong, Lei Kung, Lei Li, Lei Sun, Lei Tsen, Lei Tui	1885	No picture	27t, 26.0x3.6m, 1b,1vc, 420hp, 19.5kts; 1-356TT
	Chang Tze	2	12, 13	No1 Chang Tze, No3 Lieh Tze	1895	No picture	89t, 39.0x4.8x1.5m, 1b,1vc, 600hp, 18kts, 31p; 2x5-37/17, (2+1x1)-356TT
	Chen Tse	2	14	No2 Chen Tse	1896		126t, 43.9x5.2x2.4m, 2b,1vte, 1000hp, 18kts, 31p; 2x5-37/17, (2+1x1)-450TT
			15	No4 Su Tse	1896		
	Hu Peng	4	16	No7 Hu Peng	1906		120t, 41.1x4.9x2.1m, 2b,1vte, 1200hp, 23kts, 34p; 2x1-47/40, (1+2x1)-450TT
17			No8 Hu Oah	1906			
18			No9 Hu Ying	1907			
19			No10 Hu Chen	1907			

OTHER FIGHTING SHIPS

	Kwangtung	2	1	An Lan	1868	No picture	440t, 42.7x7.2x2.7m, 3b,1hr, 255hp, 9.3kts, 60p; 1x1-178/16, 2x1-121/22
--	-----------	---	---	--------	------	------------	---

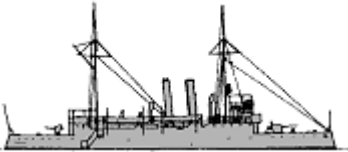
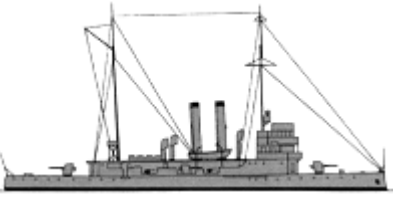
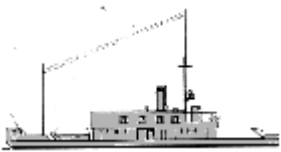
		2	Chen T'ao	1868			
PG	Chen Hai	2	3	Chen Hai	1872	No picture	578t, 49.0x8.0x3.2m, 2b,1hse, 480hp, 10kts, 70p; 2x1-160/16(3), 1x1-160/16(4), 4x1-121/22
			4	Ching Yuan	1873		
	Fei Ting	2	5	Fei Ting	1876		420t, 36.6x9.1x2.4m, 1b,2hcr, 270hp, 9.5kts, 30p; iron- 13shield, 13CT; 1x1-318/16, 2x1-70/22, 1x4-25/42
				6	Tse Tien		
	Hai Ch'ang Ch'ing	1	7	Hai Ch'ang Ch'ing	1877		430t, 38.1x9.1x2.4m, 1b,2hcr, 70hp, 7.5kts; 1x1-279/12, 2x1-76/28
	Kuang Yuan	4	8	Kuang Yuan	1886	No picture	300t, 33.8x5.5x2.3m, 2hrcr, 65-78hp, 9-10kts; 1x1-149/32, 1x1-88/32, 3x1-37/42
			9	Kuang Heng	1886		
			10	Kuang Li	1886		
			11	Kuang Chien	1886		
	Kuang Keng	4	12	Kuang Keng	1887	No picture	560t, 43.0x7.3x3.7m, 1vr, 400hp, 11kts; 2x1-121/22, 1x1-100/22, 2x1-47/40
			13	Kuang Hsing	1887		
			14	Kuang Jen	1887		
			15	Kuang Kuei	1887		
	Chen Sheng	1	16	Chen Sheng	1899	No picture	275t, 36.6x6.1x2.1m, 1vc, 400hp, 10kts, 42p; 1x1-76/40, 1x1-57/40
	Kiang Yuan	4	17	Kiang Yuan	1905		565t, 54.1x8.5x2.1m, 2b,2vte, 950hp, 13kts, 85p; 1x1-120/40, 1x1-76/40, 4x1-47/40
18			Kiang Heng	1907			
19			Kiang Li	1907			
20			Kiang Chen	1907			
Chu Tung	6	21	Chu Tung	1906		752t, 61.0x9.0x2.4m, 2b,2vte, 1350hp, 13kts, 117p; 2x1-120/40, 2x1-76/40	
		22	Chu Chien	1906			
		23	Chu Tai	1906			
		24	Chu Yu	1907			
		25	Chu Yiu	1907			
		26	Chu Kuan	1907			
Kuan Chuan	1	27	Kuan Chuan	1908	No picture	305t, 36.3x6.1x2.3m, 1b,1vc, 300hp, 7.9kts, 26p; 2x1-37/27	
An Feng	1	28	An Feng	1908	No picture	169t, 37.2x5.6x1.7m, 1b,1vc, 350hp, 12.1kts	
PGR	Chian Kung	4	1	Chian Kung	1909		200t, 44.0x6.0x2.3m, 1b,2vte, 500hp, 14kts, 62p; 1x1-76/40
			2	Chiang Chi	1909		
			3	Chiang Ku	1909		
			4	Chiang Tai	1909		

CUSTOMS FLOTILLAS

--	--	--	--	--	--	--

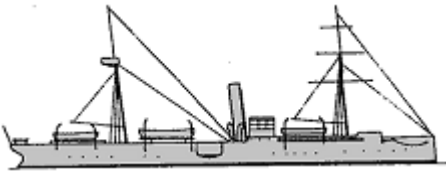
CGC	Fee Cheu	1	1	Fee Cheu	1887		1300t, 67.1x9.8x4.0m, 13kts; 2x1-152/26
	Chuen Tiao	1	2	Chuen Tiao	1888	No picture	716t, 47.3x7.6x3.5m, 10kts; 2x1-95/21, 2x1-47/40
	Likin	2	3	Likin	1888	No picture	512t, 41.2x7.0x3.5m, 10kts; 2x1-95/21, 2x1-47/40
			4	Kaipan	1888		
Liu Hsing	1	5	Liu Hsing	1902	No picture	1500t, 59.2x8.4m	

© Ivan Gogin, 2015

[home](#)[World navies yesterday](#)[1910](#)

Colombia 01 January 1910

CRUISERS

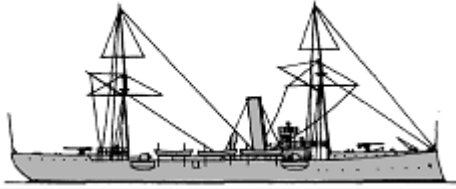
CLL	Almirante Lezo	1	1	Almirante Lezo	1892		1200t, 70.0x10.0x2.6m, 1vte, 2500hp, 18kts, 150p; 2x1-120/40, 4x1-37/25, 4-356TT
-----	----------------	---	---	----------------	------	--	--

OTHER FIGHTING SHIPS

PG	La Popa	1	1	La Popa	1887	No picture	
PGR	General Pinzón	1	1	General Pinzón	1881	No picture	740t, (stw), 13kts; 3x1-37/20
	Esperanza	2	2	Esperanza	1897	No picture	400t, 42.4ppx5.8x0.9m, (stw), 430hp, 15kts; 3x1-37/20
			3	General Nerín	1895		
	Chercinto	1	4	Chercinto	1896	No picture	643t, 56.4x9.4x3.7m, 400hp, 12kts; 3x1-37/20
APGR	-	1	1	Bolívar	1870		981t

© Ivan Gogin, 2015

[home](#)

[World navies yesterday](#)

[1910](#)

Costa Rica 01 January 1910

TORPEDO SHIPS

TB	no name	1	1	no name	1890	No picture	15t, 18.3x2.8x1.1m, 1b,1vte, 230hp, 17kts; 1x1-47/40, 1-356TT
----	---------	---	---	---------	------	------------	---

© Ivan Gogin, 2015

[home](#)[World navies yesterday](#)[1910](#)

Cuba 01 January 1910

OTHER FIGHTING SHIPS

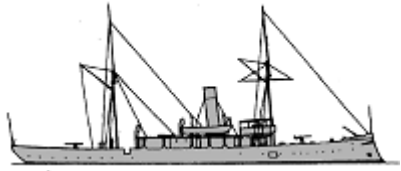
PG	Baire	1	1	Baire	1906		510t, 59.7x7.0x2.7m, 1vte, 1200hp, 14kts, 76p; 2x1-57/40, 2x1-47/40
----	-------	---	---	-------	------	--	---

COAST GUARD SHIPS





CGC	Veinte de Mayo	1	1	Veinte de Mayo	1895	No picture	203t, 45.7x5.6x3.2m, 500hp, 12kts, 43p; 2x1-47/40, 2x1-37/40
	Yara	1	2	Yara	1895	No picture	449t, 47.2x7.9x4.0m, 600hp, 12kts, 53p; 2x1-57/40, 2x1-47/40
	Alfredo	1	3	Alfredo	1896	No picture	40t, 18.3x3.7x1.8m, 11kts; 1x1-37/40
	Maceo	3	4-6	Maceo, Céspedes, Argamonte	1896	No picture	35t, 22.9x3.1x1.7m, 10kts; 1x1-37/40
	Enrique Villuendas	1	7	Enrique Villuendas	1899	No picture	178t, 40.2x6.1x2.7m, 600hp, 16kts; 2x1-47/40

© Ivan Gogin, 2015

[home](#)[World navies yesterday](#)[1910](#)

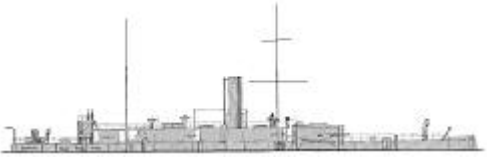
Denmark 01 January 1910

BATTLESHIPS

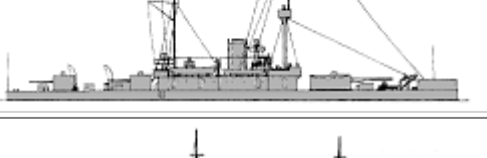





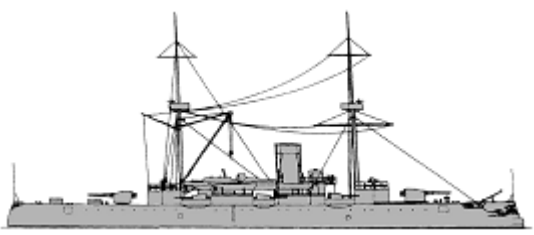
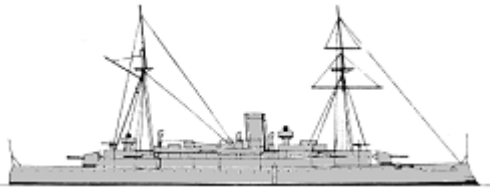
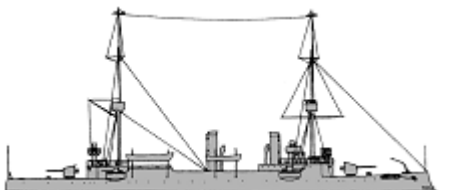



BC	Gorm	1	1	Gorm	1871		2350t, 71.7x12.2x4.4m, 4b,2hr-cr, 1600hp, 12.5kts, 160p; iron- 178side, 203turret; 1x2-149/32, 4x1-57/40, 4x5-37/17
	Odin	1	2	Odin	1874		3230t, 73.4ppx14.8x5.0m, 4b,2hr-cr, 2300hp, 12kts, 206p; compound- 203side, 203battery; 4x1-254/15, 4x1-87/21, 6x5-37/17
	Iver Hvitfeldt	1	3	Iver Hvitfeldt	1887		3478t, 74.5ppx15.1x5.6m, 8b,2vc, 5100hp, 15.2kts, 277p; compound- 295belt, 53deck, 215barbettes, 115CT; 2x1-263/32, 10x1-57/40, 8x5-37/17, 2-381TT
	Skjold	1	4	Skjold	1897		2195t, 69.4x11.6x4.2m, 4b,2vte, 2400hp, 14kts, 138p; Harvey- 229belt, 50deck, 250turret; 1x1-240/37, 3x1-120/38, 4x1-47/40
	Herluf Trolle	3	5	Herluf Trolle	1901		3650(5)-3700(6)-3785(7)t, 86.5(5,6)-87.4(7)x15.1(5)-15.4(6)-15.7(7)x5.0m, 6b,2vte, 4200(5,6)-5400(7)hp, 15.5(5,6)-16(7)kts, 258p; steel(5)- 195belt, 65deck, 175(5)-190(6,7)turrets, 190CT; 2x1-240/42(6,7), 2x1-240/38(5), 4x1-149/49(7), 4x1-149/42(5,6), 10x1-75/52(7), 10x1-57/40(5,6), 6x1-47/40(5,6), 8x1-37/20(5), 2x1-37/20(7), 3-450TT(5,6), 4-450TT(7)
		6	Olfert Fischer	1905			
		7	Peder Skram	1908			

CRUISERS

--	--	--	--	--	--	--	--

CL	Valkyrien	1	1	Valkyrien	1890		3020t, 85.8x13.2x5.5m, 6b,2vte, 5200hp, 17kts, 282p; steel- 65deck; 2x1-209/32, 6x1-149/32, 4x1-57/40, 8x5-37/17, 5-381TT
	Hekla	1	2	Hekla	1891		1300t, 72.3x10.4x3.5m, 8b,2vte, 3000hp, 17kts, 156p; steel- 43deck; 2x1-149/32, 4x1-57/40, 6x5-37/17, 4-381TT
	Gejser	2	3	Gejser	1893		1282(3)-1342(4)t, 72.3x10.4x3.5m, 8b,2vte, 3000hp, 17kts, 156p; steel- 50(3)-45(4)deck; 2x1-120/38, 4x1-87/37, 2x1-37/20, 4x5-37/17, 1-450TT, 3-381TT
4			Hejmdal	1895			
CLL	Ingolf	1	1	Ingolf	1878	No picture	1012t, 63.9x8.5x4.2m, 630hp, 10.2kts, 156p; 4x1-57/40

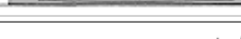
TORPEDO SHIPS

TB1cl	Nr.6	1	1	Sværdfisken	1881		58t, 33.5x3.7x1.8m, 1b,1vc, 600hp, 17kts, 15p; 1x5-37/17, 2-381TT
	Delfinen	1	2	Delfinen	1883		66t, 33.6x3.6x0.7m, 1b,1vc, 670hp, 17kts, 15p; 1x5-37/17, 2-381TT
	Hvalrossen	1	3	Hvalrossen	1884		74t, 34.5x3.7x2.0m, 1b,1vc, 660hp, 17kts, 15p; 1x5-37/17, 2-381TT
	Støren	2	4	Støren	1887		107t, 39.7x4.2x2.2m, 2b,1vc, 1200hp, 18.5kts, 20p; 2x5-37/17, (2+1x2)-381TT
			5	Søløven	1887		
	Nahrvalen	2	6	Nahrvalen	1888		111t, 41.1x4.2x2.2m, 2b,1vc, 1200hp, 18.5kts, 20p; 2x5-37/17, (2+1x2)-381TT
			7	Havhesten	1888		
	Springeren	1	8	Springeren	1891		89t, 36.3x4.0x2.1m, 2b,1vc, 800hp, 17.5kts, 17p; 2x5-37/17, 2-450TT
	Nordkaperen	2	9	Nordkaperen	1893		127t, 42.5x4.3x2.2m, 2b,1vc, 1300hp, 19kts, 20p; 2x5-37/17, 2-450TT, 1x2-381TT
			10	Makrelen	1894		
	Hajen	1	11	Hajen	1896		141t, 42.9x4.6x2.5m, 2b,2vte, 2000hp, 22kts, 25p; 1x1-47/40, 1x5-37/17, 2-450TT, 1x2-381TT
	Havørnen	2	12	Havørnen	1897		142t, 44.4x4.7x2.4m, 2b,2vte,2 100hp, 22kts, 25p; 1x1-47/40, 1x5-37/17, (2+1x2)-450TT
			13	Søbjørnen	1898		
	Ormen	1	14	Ormen	1907		105t, 38.0x4.3x2.6m, 2b,1vte, 2100hp, 26.2kts, 21p; 2x1-37/40, (1+1x2)-450TT
	Nr.4	1	1	Nr.2	1879		32t, 27.8x3.0x1.6m, 1b,1vc, 350hp, 15.5kts, 12p; 1x1-37/20, 1-356TT
	Nr.5	1	2	Nr.3	1880	No picture	37t, 29.0xxm, 1b,1vc, 450hp, 15kts; 1x1-37/20, 2-356TT

TB2cl	P8	2	3, 4	P8, 9	1894-1895	No picture	48t, 25.6x3.8x1.8m, 1vte, 330hp, 13kts, 13p; 1x1-47/40, 1x5-37/17, 1x1-356TT
	Nr.4	1	5	Nr.4	1882	No picture	15t, 18.8x2.2x1.1m, 1b,1vc, 150hp, 13kts, 6p; 1x1-37/20, 2-356TT
	Nr.6	2	6, 7	Nr.6, 7	1884	No picture	15t, 20.1x2.4x1.3m, 1b,1vc, 150hp, 13kts, 6p; 1x1-37/20, 2-356TT
	Nr.8	2	8, 9	Nr.8, 9	1886	No picture	15t, 20.6x2.4x1.2m, 1b,1vc, 170hp, 13kts, 6p; 1x1-37/20, 2-356TT
	Nr.10	2	10, 11	Nr.10, 11	1888	No picture	17t, 21.0x2.4x1.2m, 1b,1vc, 180hp, 13.5kts, 6p; 1x1-37/20, 2-356TT
	Nr.12	2	12, 13	Nr.12, 13	1889	No picture	25t, 23.8x2.7x1.3m, 1b,1vc, 350hp, 15kts, 6p; 1x1-37/20, 2-356TT
	P4	4	14-17	P4-7	1889-1890	No picture	20t

SUBMARINES

SS	Dykkeren	1	1	Dykkeren	1909		105/132t, 34.7x3.3x2.2m, 2pe/2m, 500/210hp, 12/7.5kts, 9p; 2-450TT
----	----------	---	---	----------	------	--	--

OTHER FIGHTING SHIPS

PG	Falster	1	1	Falster	1874		390t, 34.3x8.8x2.6m, 510hp, 10.5kts, 50p; 1x1-57/40, 6x5-37/17
	Øresund	3	2	Øresund	1875	No picture	240t, 26.1x8.0x2.1m, 200hp, 7.5kts, 36p; 1x1-57/40, 6x5-37/17
			3	Store Bælt	1875		
			4	Lille Bælt	1876		
	Grønsund	2	5	Grønsund	1883	No picture	247(5)-268(6)t, 36.3x6.1x2.5m, 300(5)-400(6)hp, 10(5)-10.5(6)kts, 46-49p; 2x1-57/40(5), 2x1-47/40(6), 2x5-37/17(5)
			6	Guldborgsund	1885		

MINE WARFARE SHIPS

ML	Hjælperen	1	1	Hjælperen	1891	No picture	288t, 38.3x6.8x2.3m, 330hp, 25p; 3x5-37/17, mines
----	-----------	---	---	-----------	------	------------	---

FISHING PROTECTION VESSELS

FPV	Beskytteren	1	1	Beskytteren	1900		415t, 43.4x7.6x3.8m, 2b,1vte, 625hp, 11kts, 47p; 1x1-47/40, 2x1-37/20
	Islands Falk	1	2	Islands Falk	1906	No picture	760t, 56.0x8.9x5.2m, 2b,1vte, 1100hp, 13kts, 63p; 2x1-75/52, 2x1-47/40

[home](#)[World navies yesterday](#)[1910](#)

Dominican Republic 01 January 1910

OTHER FIGHTING SHIPS

PG	El Presidente	1	1	El Presidente	1873	No picture	389t, 63.7x6.6m, 105hp, 13.8kts, 50p; 4x1-121/22
	Independencia	1	2	Independencia	1894	No picture	322t, 51.8x7.6m, 2vte, 15kts; 7x1-small guns
	Restauración	1	3	Restauración	1896	No picture	1000t, 65.2x9.1m, 2vte, 14kts; 4x1-120/40, 5x1-small guns

© Ivan Gogin, 2015

[home](#)[World navies yesterday](#)[1910](#)

Ecuador 01 January 1910

TORPEDO SHIPS

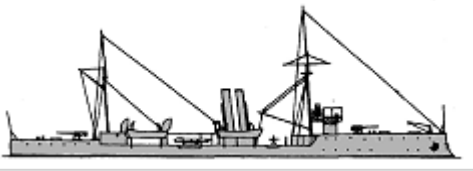
PGT	Libertador Bolívar	1	1	Libertador Bolívar	1896		800t, 73.2ppx8.4x4.3m, 4b,2vte, 4500hp, 21.5kts; steel- 25deck, 51CT; 2x1-120/40, 4x1-47/40, (1+2x1)-450TT
TB	Tungurahua	1	1	Tungurahua	1890s		65t

ESCORTS

AY	-	1	1	Cotopaxi	1884		300t; 4x1-76/40
----	---	---	---	----------	------	--	-----------------

OTHER FIGHTING SHIPS



PG	Papin	1	Inconstant	1887		877t, 61.3x8.0x4.2m, 6b,1hc(1)-4b,1hc(2), 1100hp, 12kts, 116p; 3x1-139/30, 1x1-100/26, 5x5-37/17
		2	Papin	1887		
APG	-	1	Nueve de Julio			300brt
		2	Patria			

© Ivan Gogin, 2015

[home](#)[World navies yesterday](#)[1910](#)

Egypt 01 January 1910

ESCORTS

PC	Noor El Bahr	1	1	Noor El Bahr	1884		450t
	Nesim	1	2	Nesim	1885	No picture	81t
	Marda	1	3	Marda	1886	No picture	154t
	Zarif	1	4	Zarif	1886	No picture	144t
	Saria	1	5	Saria	1886	No picture	71t
	Abbas	1	6	Abbas	1891		298brt
APC	-	1	1	Abdul Monaym	1902		610t

OTHER FIGHTING SHIPS

PG	Khartum	1	1	Khartum	1862	No picture	455t
	Dongola	1	2	Dongola	1863	No picture	300t
	Jeafferieh	1	3	Jeafferieh	1865	No picture	690t
PGR	Tamai	4	1-4	Tamai, Hafir, Metemmeh, Abu Klea	1884-1885	No picture	74t, (stw); 1x1-76/40
	El Zafir	3	5	El Zafir	1896	No picture	128t, (stw); 1x1-76/40
			6	El Fateh	1897		
			7	El Nasir	1897		
	Sultan	3	8	Sheik	1896	No picture	140t; 1x1-76/40
			9	Sultan	1896		
			10	Melik	1897		

[home](#)

[World navies yesterday](#)

[1910](#)

El Salvador 01 January 1910

OTHER FIGHTING SHIPS

PG	Cuscatlan	1	1	Cuscatlan	1890	No picture	75t, 10kts; 1x1-small gun
----	-----------	---	---	-----------	------	------------	---------------------------

© Ivan Gogin, 2015

[home](#)[World navies yesterday](#)[1910](#)

France 01 January 1910

BATTLESHIPS

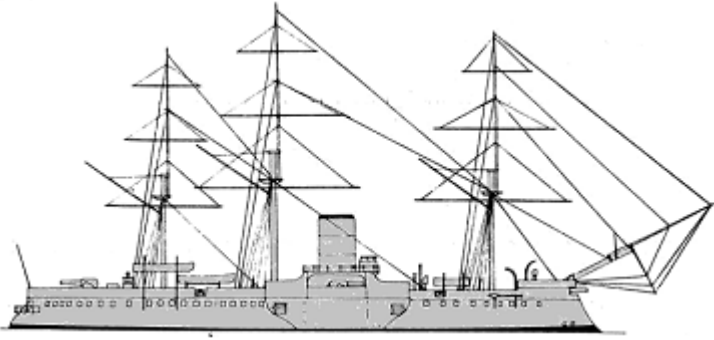
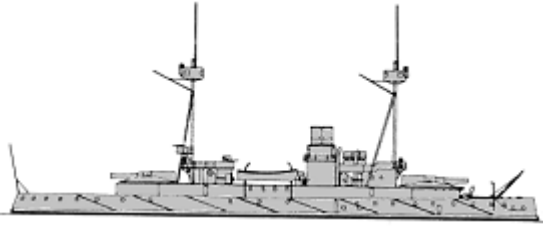
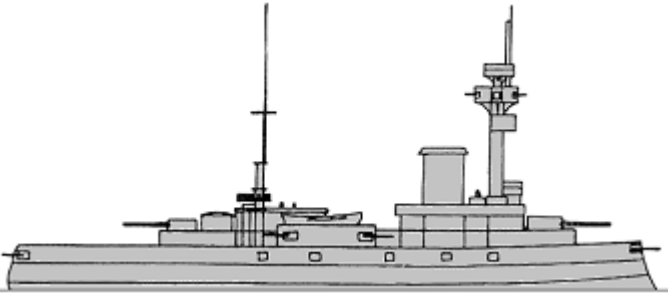
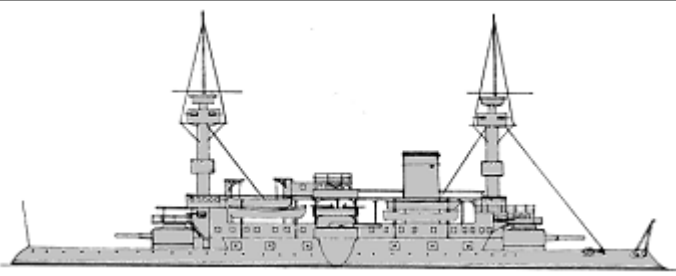
Redoutable	1	1	Redoutable	1878		9224t, 100.7x19.7x7.8m, 8b,1vte, 6200hp, 14.7kts, 705p; iron- 350belt, 60deck, 300battery; 3x1-274/40, 1x1-274/29, 4x1-240/30, 6x1-100/45, 5x1-65/50, 14x1-47/40, (5x5+5x1)-37/20, 2-350TT
Terrible	4	2	Terrible	1887		7530t, 85.3x18.0x8.0m, 12b,2vc(2-4)-12b,2vte(5), 6500(2-4)-11200(5)hp, 14.5(2-4)-15(5)kts, 373p; steel(2)- compound(3-5)- 500belt, 105deck, 450barbettes, 30CT; 2x1-340/35(2), 2x1-274/40(3-5), 4x1-100/26(2), 6x1-100/45(3-5), 4x1-47/40(2), 14x1-47/40(3-5), 16x5-37/20(2), 4-350TT(2), 2-350TT(3,4)
		3	Indomptable	1887		
		4	Caïman	1888		
		5	Requin	1888		
Amiral Baudin	1	6	Formidable	1889		11720t, 101.0x21.3x8.5m, 12b,2vc, 9700hp, 16kts, 650p; steel/compound- 550belt, 100deck, 400barbettes, 120CT; 2x1-370/28, 8x1-165/30, 10x1-139/28, 1x1-47/40, 12x5-47/20, 18x5-37/20, 4-380TT
Hoche	1	7	Hoche	1890		10580t, 102.6x20.2x8.3m, 16b,2vte, 12000hp, 16.5kts, 611p; compound- 450belt, 100deck, 400turrets, 65CT; 2x1-340/29, 2x1-274/29, 12x1-139/45, 4x1-65/50, 10x1-47/40, 10x5-37/20, 3-380TT
		8	Marceau	1891		

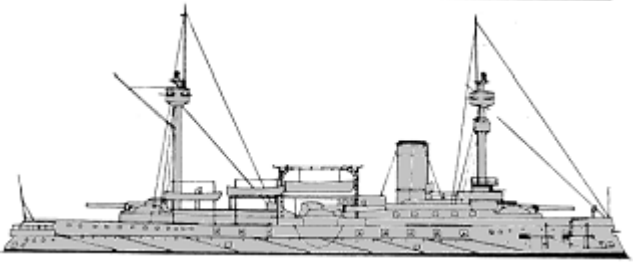
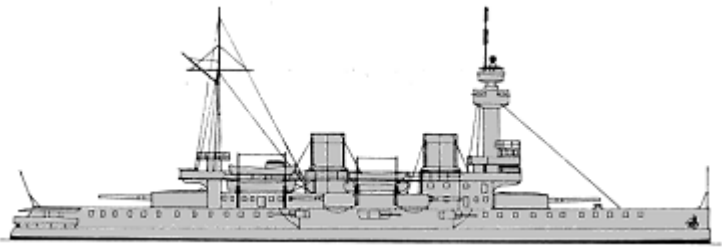
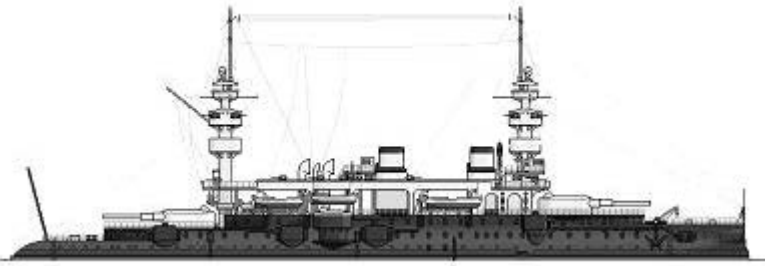
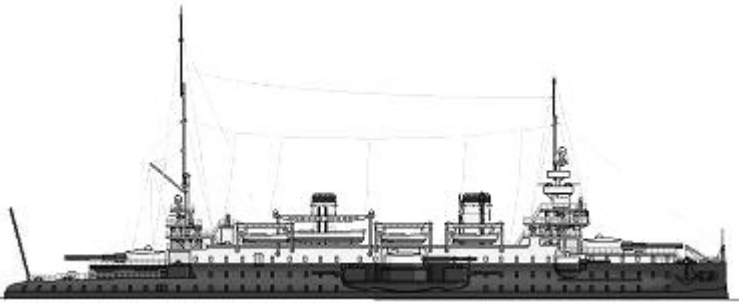
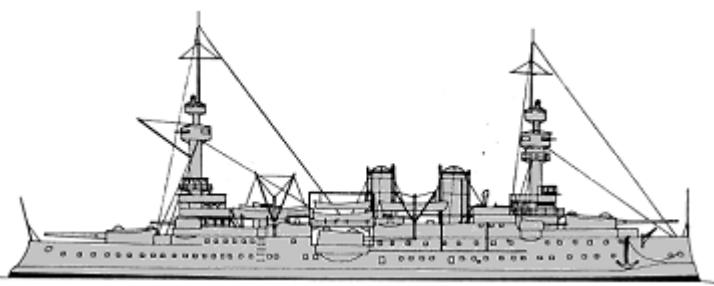
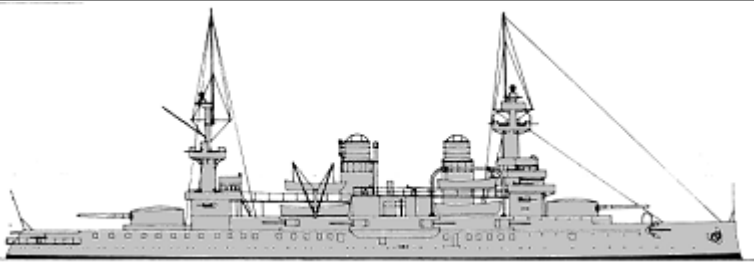
BB	Marceau	3	9	Magenta	1893		10558(8)-10680(9)t, 101.6x20.2(8)-20.0(9)x8.2-8.4m, 16b.2vc(8)-8b.2vc(9), 11000hp, 16kts, 643-651p; compound(8)-steel(9)- 450belt, 90deck, 400barbettes, 150CT; 4x1-340/29, 16x1-139/30(8), 17x1-139/30(9), 3x1-65/50(8), 6x1-65/50(9), 9x1-47/40(8), 18x1-47/40(9), 8x5-37/20(8), 12x5-37/20(9), 3-380TT(8), 5-380TT(9)
	Brennus	1	10	Brennus	1896		11190t, 114.0x20.4x8.3m, 32b,2vte, 13900hp, 18kts, 673p; steel/compound-450belt, 80deck, 450turrets, 150CT; (1x2+1x1)-340/42, 10x1-165/45, 4x1-65/50, 14x1-47/40, 8x1-37/20
	Charles Martel	1	11	Charles Martel	1897		11693t, 119.0x21.6x8.4m, 24b,2vte, 14900hp, 18kts, 644p; nickel steel- 450belt, 70deck, 380turrets, 230CT; 2x1-305/45, 2x1-274/45, 8x1-139/45, 4x1-65/50, 16x1-47/40, 8x5-37/20, 2-450TT
	Carnot	1	12	Carnot	1897		11954t, 119.0x21.4x8.4m, 24b,2vte, 16300hp, 17.8kts, 647p; nickel steel- 450belt, 70deck, 380turrets, 230CT; 2x1-305/45, 2x1-274/45, 8x1-139/45, 4x1-65/50, 16x1-47/40, 8x5-37/20, 2-450TT
	Jauréguiberry	1	13	Jauréguiberry	1897		11637t, 111.9x22.2x8.4m, 24b,2vte, 14400hp, 17.7kts, 631p; nickel steel- 450belt, 70deck, 380turrets, 230CT; 2x1-305/45, 2x1-274/45, 4x2-139/45, 4x1-65/50, 18x1-47/40, 8x5-37/20, 2-450TT
	Charlemagne	3	14	Charlemagne	1897		11300t, 117.7x20.2x8.4m, 20b,3vte, 15000hp, 18kts, 694p; Harvey- 400belt, 90deck, 380turrets, 330CT; 2x2-305/40, 10x1-139/45, 8x1-100/45, 20x1-47/40, 4x1-37/20, 2-450TT
			15	Gaulois	1899		
16	Saint-Louis	1900					

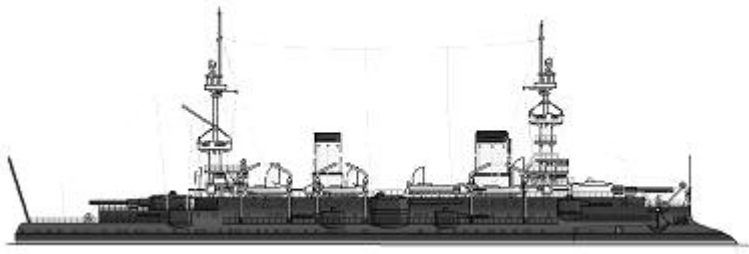
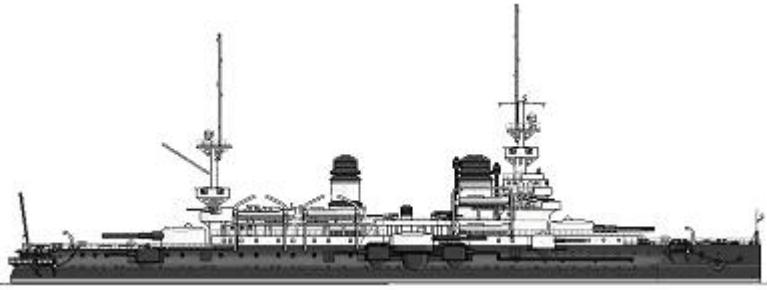
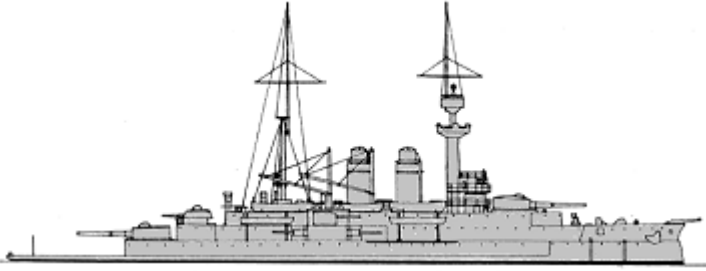
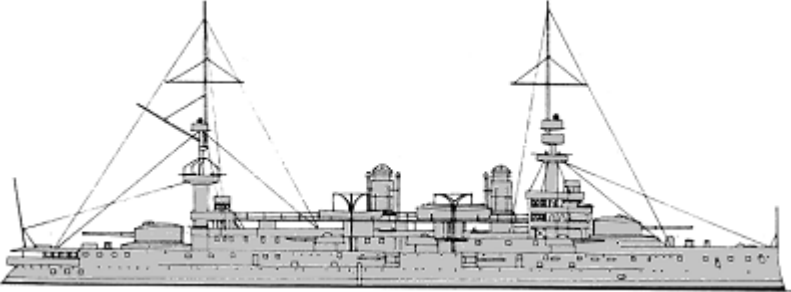
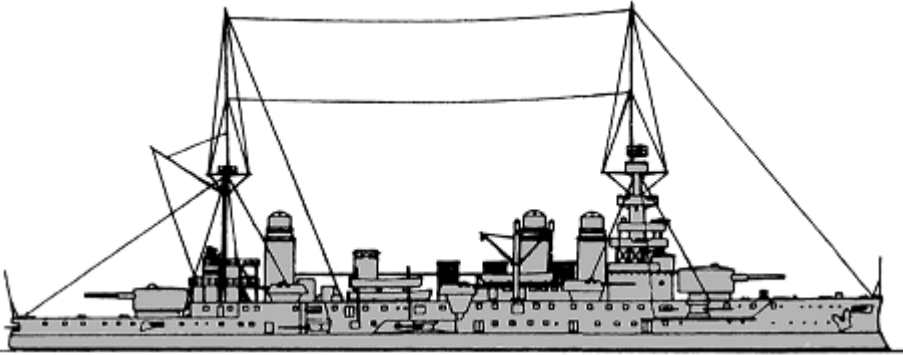

Masséna	1	17	Masséna	1898		11735t, 115.5x20.3x8.8m, 24b,3vte, 14200hp, 17kts, 667p; nickel steel- 450belt, 110decks, 400turrets, 350CT; 2x1-305/40, 2x1-274/45, 8x1-139/45, 8x1-100/45, 12x1-47/40, (3x5+5x1)-37/20, 2-450TT
Bouvet	1	18	Bouvet	1898		12007t, 122.6x21.4x8.4m, 32b,3vte, 15000hp, 18kts, 666p; Harvey- 400belt, 70decks, 380turrets, 300CT; 2x1-305/40, 2x1-274/45, 8x1-139/45, 8x1-100/45, 12x1-47/40, (2x5+5x1)-37/20, 2-450TT
Henry IV	1	19	Henry IV	1903		8948t, 108.0x22.2x7.0m, 12b,3vte, 11000hp, 17kts, 464p; Harvey- 280belt, 80deck, 300turrets, 240CT; 2x1-274/40, 7x1-139/45, 12x1-47/40, 2x1-37/20, 2-450TT
Suffren	1	20	Suffren	1903		12892t, 125.9x21.4x8.4m, 24b,3vte, 16700hp, 17kts, 714p; Harvey- 300belt, 110deck, 325turrets, 300CT; 2x2-305/40, 10x1-165/45, 8x1-100/45, 22x1-47/40, 2x1-37/20, 2-450TT
République	2	21	République	1906		14605(21)-14900(22)t, 134.8x24.3x8.4m, 24b,3vte, 18000hp, 19kts, 825p; 280belt, 55deck, 360turrets, 300CT; 2x2-305/40, (6x2+6x1)-165/45, 25x1-47/50, 2-450TT
		22	Patrie	1906		
Démocratie	4	23	Démocratie	1908		14489-14860t, 134.8x24.3x8.4m, 22b,3vte(23,25,26)-24b,3vte(24), 18500hp, 19kts, 769p; 280belt, 55deck, 360turrets, 300CT; 2x2-305/40, 10x1-194/50, 13x1-65/50, 10x1-47/50, 2-450TT
		24	Justice	1908		
		25	Liberté	1908		

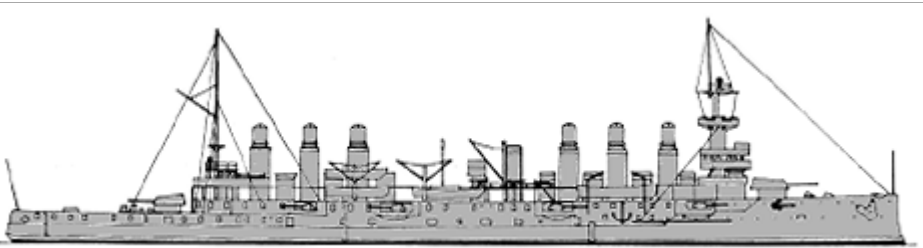
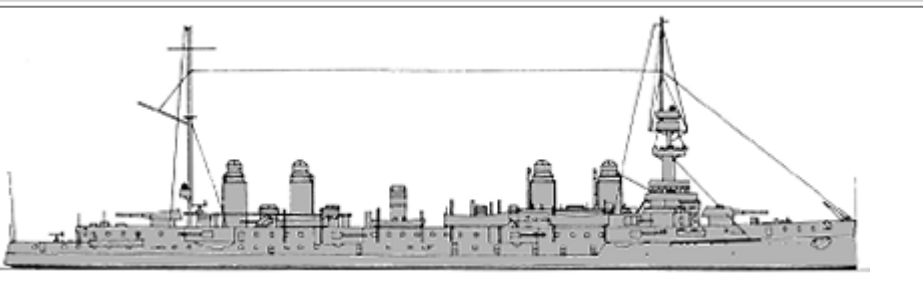
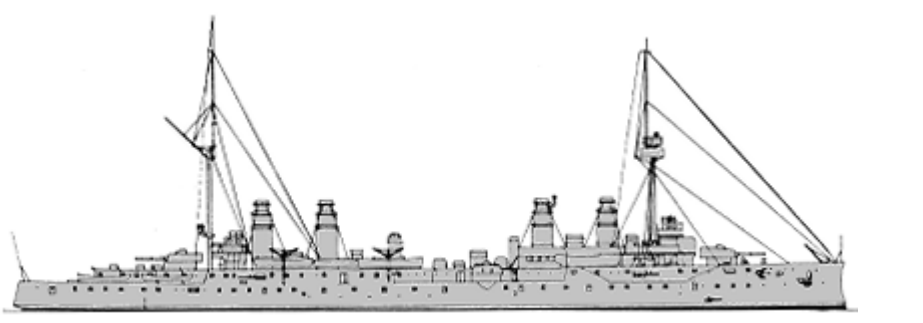
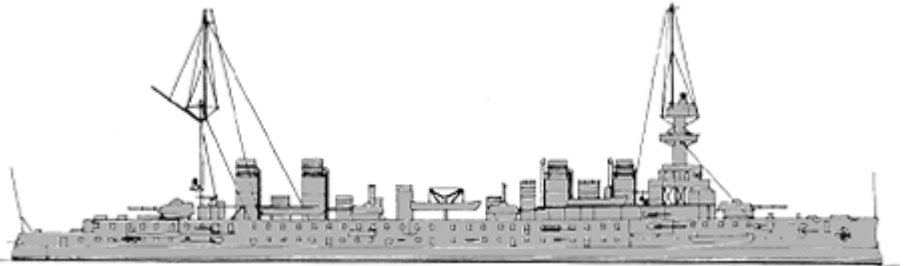
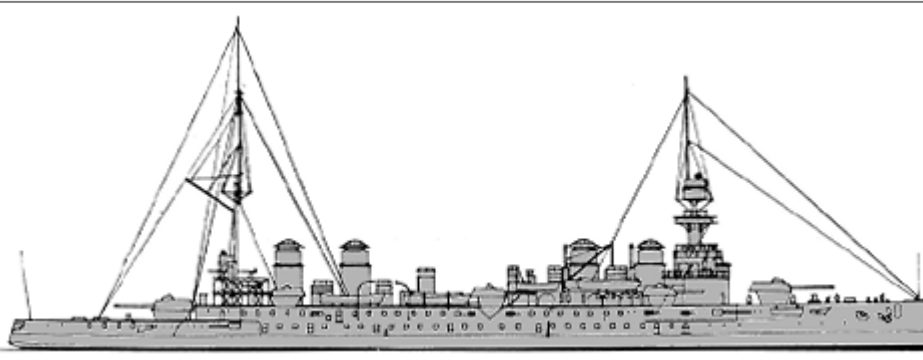

		26	Verité	1908			
BC	Furieux	1	1	Furieux	1887		5683t, 75.9x17.8x6.9m, 8b,2vte, 5145hp, 14.3kts, 235p; steel- 450belt, 90deck, 450barbettes; 2x1-240/40, 6x1-47/40, 10x5-37/20, 2-350TT
	Jemmapes	2	Jemmapes	1894		6476t, 89.7x17.5x7.1m, 16b,2hte, 9000hp, 16.7kts, 313p; NS- 450belt, 100deck, 450turrets, 100CT; 2x1-340/42, 4x1-100/45, 4x1-47/40, 10x5-37/20, 2-450TT	
		3	Valmy	1894			
Amiral Tréhouart	2	4	Amiral Tréhouart	1896		6681t, 89.7x17.8x7.1m, 16b,2vte, 8500hp, 16.5-17kts, 343-362p; NS- 450belt, 110deck, 450turrets, 100CT; 2x1-305/45, 8x1-100/45, 4x1-47/40, 10x5-37/20(4), (8x5+4x1)-37/20(5), 2-450TT	
		5	Bouvines	1894			

CRUISERS

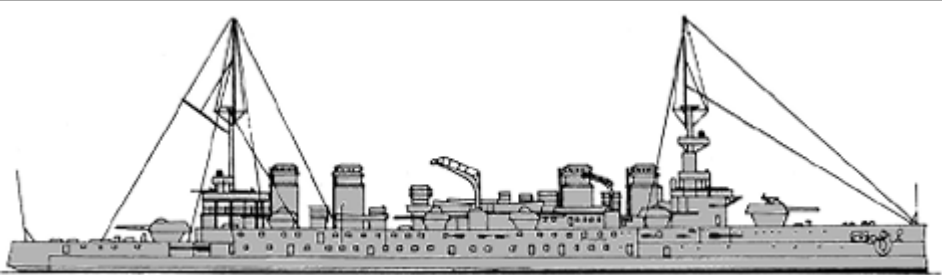
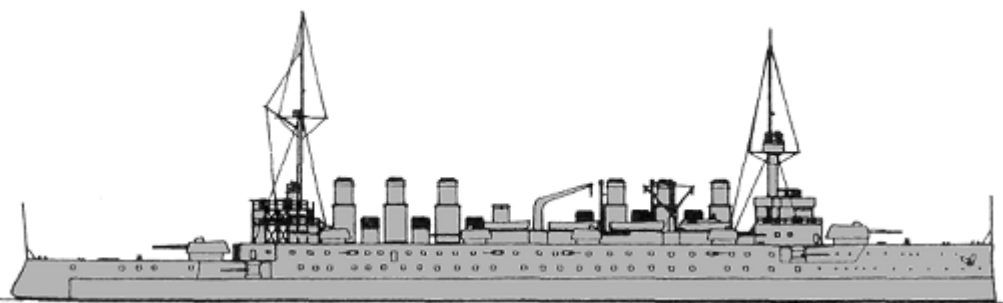
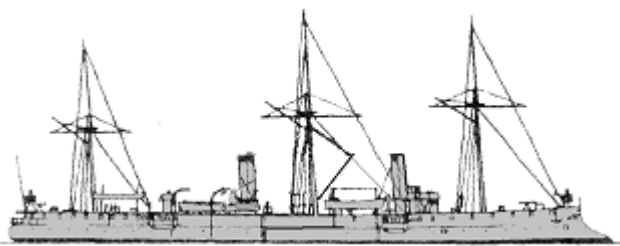
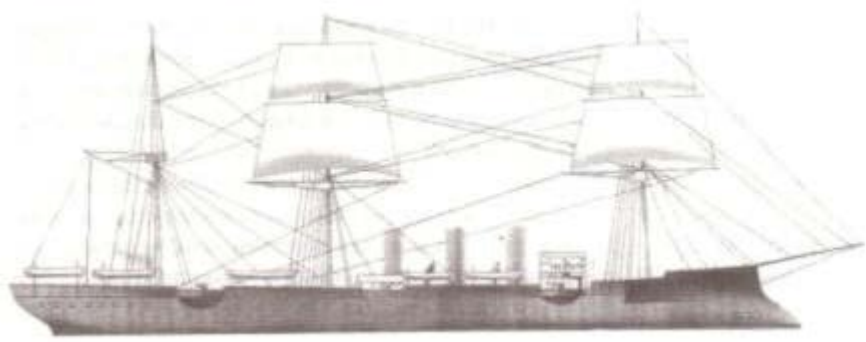
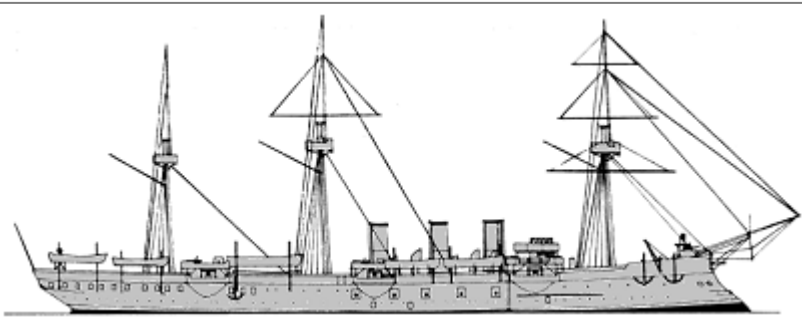
Amiral Charner	3	1	Amiral Charner	1894		4681-4736t, 110.0x14.0x6.0m, 16b,3hte, 8000hp, 18.2kts, 393p; steel- 90belt, 40deck, 110turrets, 110CT; 2x1-194/45, 6x1-139/45, 4x1-65/50, 4x1-47/40, 6x5-37/20, 4-450TT
		2	Bruix	1896		
		3	Latouche-Tréville	1895		
Dupuy de Lôme	1	4	Dupuy de Lôme	1895		6676t, 114.0x15.7x7.5m, 20b,2hte+1vte, 13000hp, 19.7kts, 526p; steel- 100belt, 20deck, 200turrets, 130CT; 2x1-194/45, 6x1-165/45, 4x1-65/50, 8x1-47/40, 8x5-37/20, 2-450TT
Pothuau	1	5	Pothuau	1897		5374t, 113.0x15.3x6.5m, 18b,2vte, 10000hp, 19kts, 459p; NS- 60belt, 35deck, 170turrets, 230CT; 2x1-194/40, 10x1-139/45, 10x1-47/40, 8x1-37/20, 4-450TT

						11270t, 145.4x19.4x8.1m, 48b,3vte, 33000hp, 21.8kts, 651p; Harvey-150belt, 65deck, 160turrets, 150CT; 2x1-194/40, 14x1-139/45, 16x1-47/40, 6x1-37/20, 2-450TT
						9177(7)-9548(8)-9367(9)t, 138.0x19.4x7.7m, 20b,3vte(7)-28b,3vte(8,9), 19600(7,8)-22000(9)hp, 21(7,8)-22(9)kts, 566p; Harvey- 150belt, 55deck, 200turrets, 160CT; 2x1-194/40, 8x1-165/45, 4x1-100/45, 16x1-47/40, 4x1-37/20, 2-450TT
						7432(10)-7547(11)-7602(12)t, 130.0x17.8x7.4m, 24b,3vte(10,11)-20b,3vte(12), 17500hp, 21kts, 531p; Harvey- 100belt, 70deck, 160turrets, 80CT; 4x2-165/45, 4x1-100/45, 10x1-47/40, 4x1-37/20, 2-450TT
						9534(13)-10233(14)-10212(15)-9458(16)t, 139.8x20.2x7.5-7.7m, 24b,3vte(13,16)-28b,3vte(14,15), 21800hp, 21.5kts, 615p; Harvey-150belt, 80deck, 170turrets, 150CT; 2x1-194/40, 8x1-165/45, 6x1-100/45, 18x1-47/40, 2-450TT
						11959(17)-12379(18)-13108(19)t, 146.5x21.4x8.1-8.4m, 28b,3vte(17,19)-20b,3vte(18), 28500hp, 22.5kts, 728p; 150belt, 35deck, 200turrets, 200CT; 2x2-194/40, (6x2+4x1)-165/45, 24x1-47/40, 2x1-37/20, 2-450TT
CA	Jeanne d'Arc	1	6	Jeanne d'Arc	1902	
	Gueydon		7	Montcalm	1902	
			8	Gueydon	1903	
			9	Dupetit-Thouars	1905	
	Duplex		10	Duplex	1903	
			11	Desaix	1904	
			12	Kléber	1904	
	Gloire		13	Amiral Aube	1904	
			14	Condé	1904	
			15	Gloire	1904	
			16	Marseillaise	1903	
	Léon Gambetta		17	Léon Gambetta	1905	
			18	Jules Ferry	1905	
			19	Victor Hugo	1907	
	Jules Michelet	1	20	Jules Michelet	1908	13105t, 146.5x21.4x8.4m, 28b,3vte, 30000hp, 22.5kts, 770p; 150belt, 35deck, 200turrets, 200CT; 2x2-194/50, 12x1-165/45, 24x1-47/50, 2-450TT

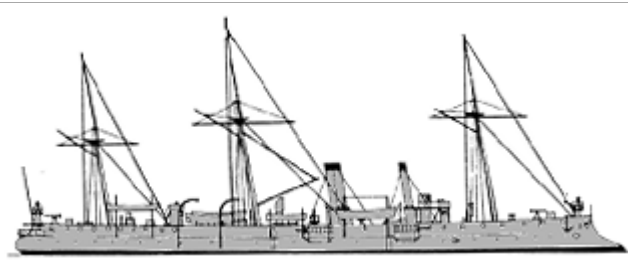
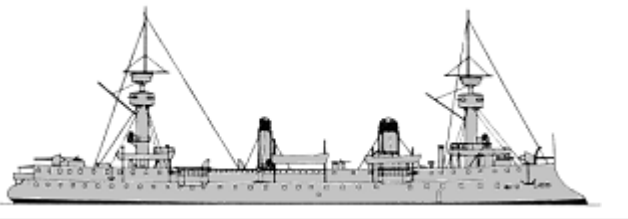
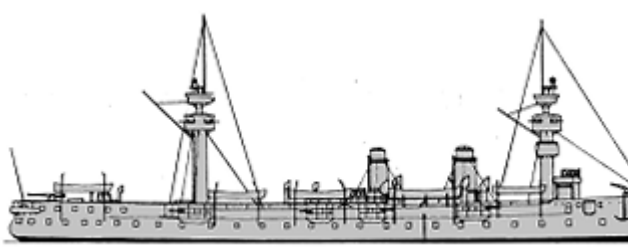
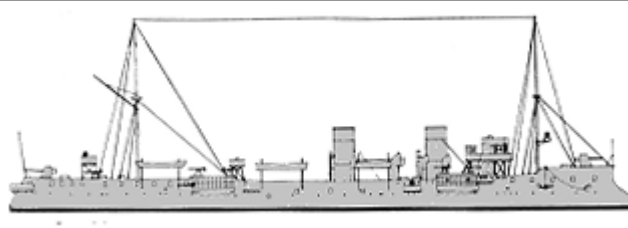
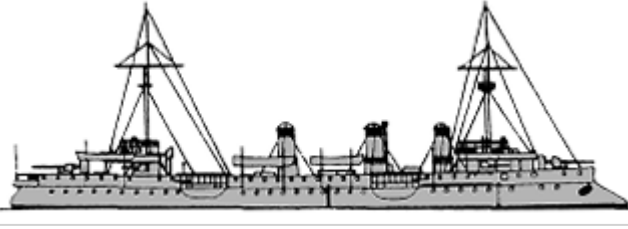
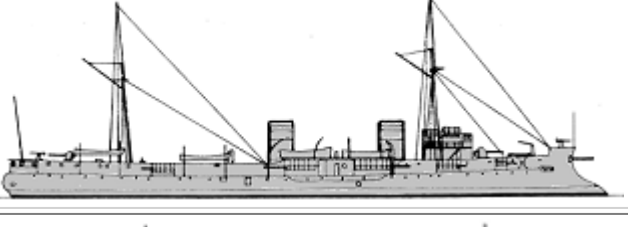
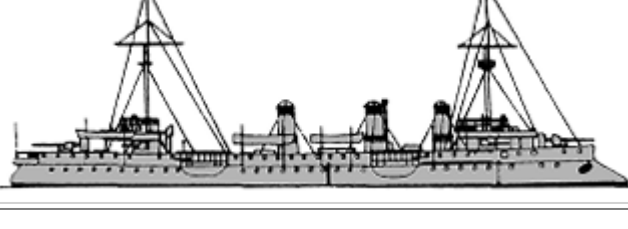

					
Ernest Renan	1 21	Ernest Renan	1909		13504t, 159.0x21.3x8.4m, 42b,3vte, 36000hp, 23kts, 824p; 150belt, 35deck, 200turrets, 200CT; 2x2-194/50, 12x1-165/45, 16x1-65/50, 8x1-47/50, 2x1-37/20, 2-450TT
Forbin	1	Forbin	1889		1935(1)-2012(2)t, 95.0x9.0x5.2m, 6b,2hc, 5800hp, 20-20.5kts, 199p; steel- 40deck, 20CT(2); 4x1-139/30, 8x1-47/40, 4x5-37/20, 150mines
	2	Surcouf	1890		
Tage	1 3	Tage	1890		7469t, 118.9x16.3x7.7m, 12b,2hte, 12500hp, 19.2kts, 538p; steel- 55slopes, 50deck, 90CT; 8x1-165/30, 8x1-139/30, 6x1-47/40, 16x1-37/20, 4-380TT
Amiral Cécille	1 4	Amiral Cécille	1890		5839t, 115.5x15.0x6.8m, 12b,4vc/2, 10200hp, 19.4kts, 517p; steel- 100slopes, 55deck, 90CT; 8x1-165/30, 10x1-139/30, 6x1-47/40, 14x5-37/20, 3-380TT
Troude	5	Cosmao	1891		1923(5)-1968(6)t, 95.0x9.0x5.2m, 5b,2hc, 5800hp, 20.5kts, 201p; steel- 40deck, 25CT(6); 4x1-139/30, 10x1-47/40, 4x1-37/20, 150mines
	2 6	Lalande	1890		

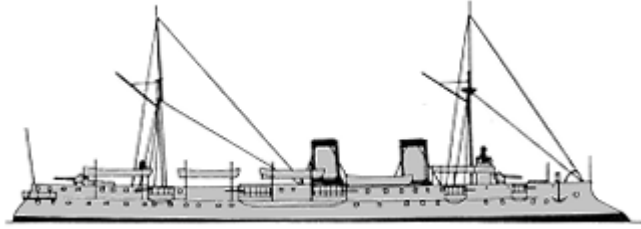
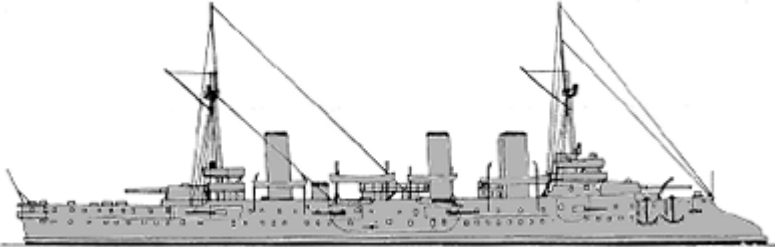
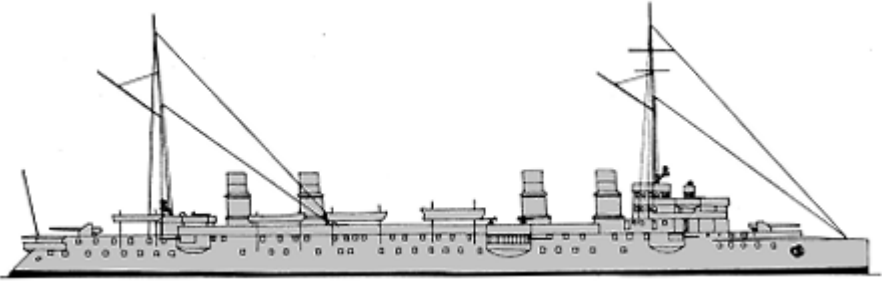
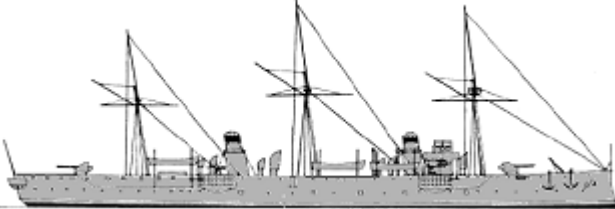
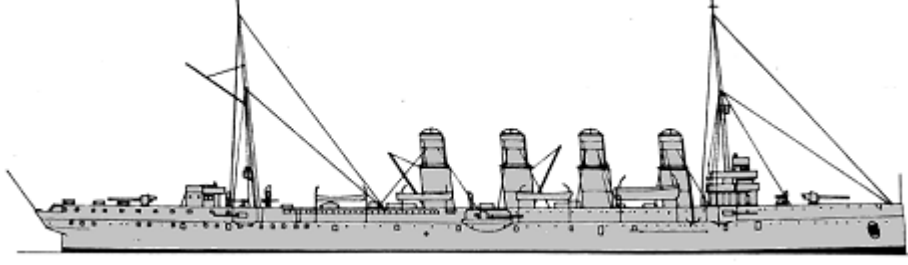
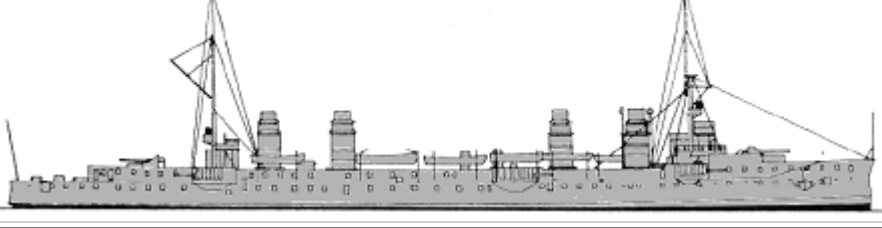

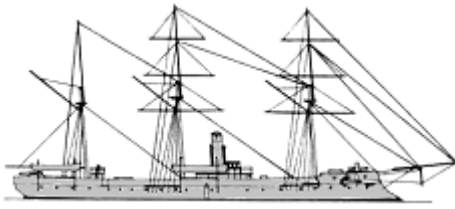
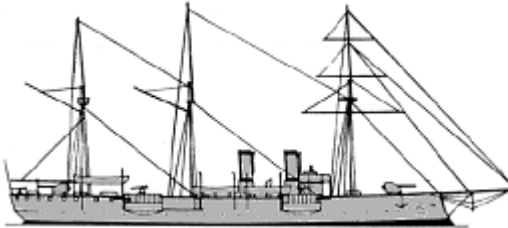

						
						
Davout	1	7	Davout	1891		3031t, 88.0x12.0x6.6m, 10b,2ite, 9000hp, 20.7kts, 329p; steel- 100slopes, 50deck, 70CT; 6x1-165/30, 4x1-65/50, 4x1-47/40, 2x1-37/20, 2-350TT
Alger	2	8	Alger	1891		4313(8)-4406(9)t, 107.0x13.0x6.1-6.5m, 24b,2vte(8)-8b,2hte(9), 8000hp, 19(8)-19.5(9)kts, 387(8)-405(9)p; steel- 100slopes, 50deck, 50shields(9), 50(8)-75(9)CT; 4x1-165/28, 6x1-139/30, 2x1-65/50, 8x1-47/40(8), 12x1-47/40(9), 8x5-37/20(8), 10x5-37/20(9), 7-350TT
		9	Isly	1893		
Linois	3	10	Linois	1895		2285(10)-2318(11,12)t, 98.0(10)-100.6(11,12)x10.6(10,12)-11.0(11)x5.4m, 6b,2vte(10)-16b,2vte(11,12), 6800hp, 20.5kts, 201p; steel- 40deck, 75shields, 125CT; 4x1-139/45, 2x1-100/45, 10x1-47/40, 4-450TT(10), 2-450TT(11,12), 120mines(10,11)
		11	Galilée	1897		
		12	Lavoisier	1898		
Friant	3	13	Friant	1895		3982(13)-3824(14)-3809(15)t, 97.0x13.0x6.3m, 20b,2vte(13,14)-24b,2vte(15), 9500hp, 18.7kts, 339p; steel- 80slopes, 30deck, 50shields, 75CT; 6x1-165/45, 4x1-100/45, 4x1-47/40, 11x1-37/20, 2-350TT
		14	Chasseloup-Laubat	1895		
		15	Bugeaud	1896		
Descartes	2	16	Descartes	1896		3960t, 99.0x13.0x6.5m, 16b,2vte, 8500hp, 19.5kts, 383(16)-401(17)p; steel- 60slopes, 45deck, 50shields, 70CT; 4x1-165/45, 10x1-100/45, 8x1-47/40(16), 14x1-47/40(17), 4x1-37/20(16), 8x1-37/20(17), 2-450TT
		17	Pascal	1897		
D'Assas	3	18	Cassard	1898		3890(18,20)-3962(19)t, 99.0x13.7x6.3m, 20b,2vte, 10000hp, 20kts, 370-392p; 100slopes, 70deck, 50shields, 100CT; 6x1-165/45, 4x1-100/45, 10x1-47/40, 9x1-37/20(18,20), 5x1-37/20(19), 2-450TT
		19	D'Assas	1898		
		20	Du Chayla	1898		
		21	Catinat	1898		

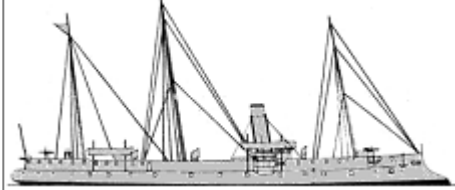
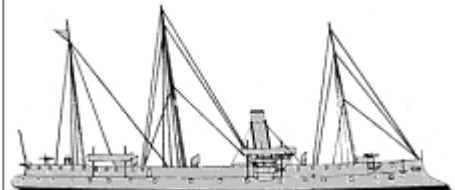

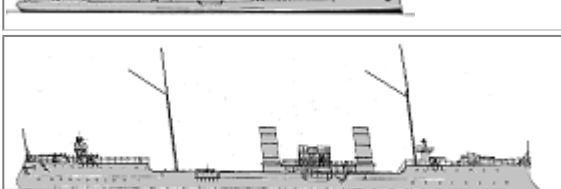

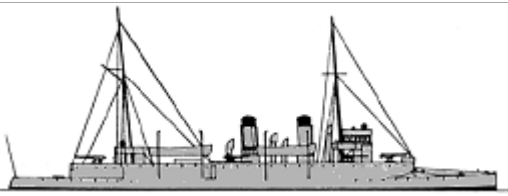

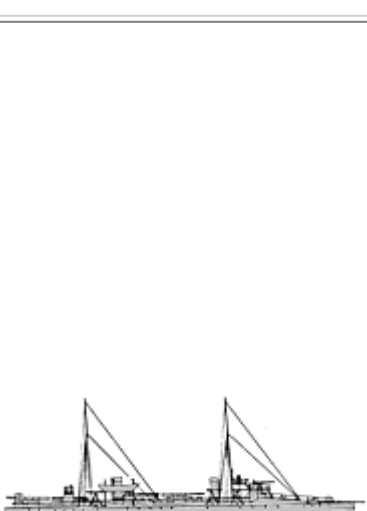

Catinat	2	22	Protet	1899		4048(21)-4001(22)t, 101.0x13.6x6.4m, 16b,2vte, 9500hp, 19.5(21)-20(22)kts, 400p; steel- 60slopes, 45deck, 50shields, 70CT; 4x1-165/45, 10x1-100/45, 10x1-47/40, 4x1-37/20, 2-350TT, 50mines
D'Entrecasteaux	1	23	D'Entrecasteaux	1899		8142t, 120.0x17.8x7.5m, 5b,2vte, 14500hp, 19.2kts, 559p; Harvey-100slopes, 55deck, 250turrets, 250CT; 2x1-240/40, 12x1-139/30, 12x1-47/40, 6x1-37/20, 6-450TT
Guichen	1	24	Guichen	1899		8151t, 139.0x17.0x7.5m, 36b,3vte, 25000hp, 23.5kts, 604p; Harvey-100slopes, 55deck, 60casemates, 160CT; 2x1-165/45, 6x1-139/45, 10x1-47/40, 5x1-37/20, 2-450TT
D'Estrées	2	25	D'Estrées	1899		2428t, 95.0x12.0x5.4m, 8b,2vte, 8500hp, 20.5kts, 235p; steel- 43deck; 2x1-139/45, 4x1-100/45, 8x1-47/40, 2x1-37/20
		26	Infernet	1900		
Châteaurenault	1	27	Châteaurenault	1902		7898t, 135.0x17.0x7.4m, 14b,3vte, 23000hp, 24kts, 604p; Harvey-100slopes, 55deck, 60casemates, 160CT; 2x1-165/45, 6x1-139/45, 10x1-47/40, 5x1-37/20
Jurien de la Gravière	1	28	Jurien de la Gravière	1903		5595t, 137.0x15.0x6.3m, 24b,3vte, 17400hp, 22.9kts, 463p; 65slopes, 80deck, 70shields, 100CT; 8x1-165/45, 10x1-47/40, 6x1-37/20, 2-450TT
Inconstant	1	1	Fulton	1888		898t, 61.3x8.0x4.2m, 6b,1hc, 1100hp, 13.8kts, 116p; 3x1-139/30, 1x1-

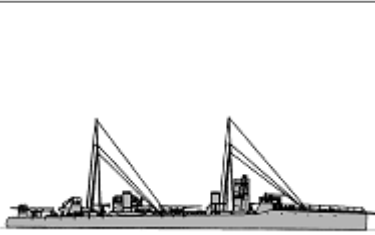

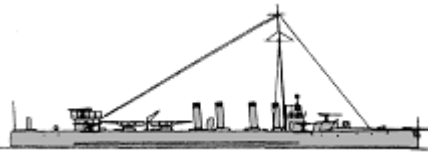







CLL						100/26, 5x5-37/20
	Kersaint	1 2	Kersaint	1898		1276t, 68.6x10.5x4.6m, 4b,1vte, 2400hp, 16kts, 146p; 1x1-139/45, 5x1-100/45, 7x1-37/20





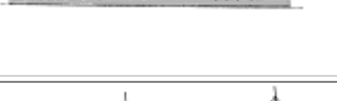

TORPEDO SHIPS

PGT	Condor	1	Épervier	1887		1268(1)-1311(2)t, 68.0ppx9.0x4.7m, 4b,2ic, 3000hp, 17kts, 137p; steel- 40deck; 5x1-100/26, 4x1-47/40, 6x5-37/20	
		2	Faucon	1887			
	Wattignies	1	3	Fleurus	1898		1280t, 68.0ppx8.9x4.8m, 8b,2hte, 4000hp, 18kts, 173p; steel- 40deck; 5x1-100/26, 6x1-47/40, 4x1-37/20
	Bombe	6	4	Bombe	1887		369-430t, 59.2ppx6.0x3.2m, 4b,2vc, 1800hp, 18-19kts, 70p; steel- 13CT; 2x1-47/40, 5x1-37/20, 2x1-350TT
			5	Couleuvrine	1887		
			6	Dragonne	1888		
			7	Flèche	1888		
			8	Lance	1890		
	Lévrier	2	9	Sainte-Barbe	1890		503t, 63.0x7.0x3.2m, 6b,2vte, 2400hp, 89p; 1x1-65/50, 3x1-47/40, 2x1-37/20, 2x1-450TT
			10	Léger	1891		
	D'Iberville	3	11	Lévrier	1891		952(12)-970(13,14)t, 81.9x8.1(12)-8.2(13,14)x3.5m, 8b,2vqe(12,13)-8b,2vte(14), 5000hp, 21.5-22kts, 143(12)-140(13,14)p; steel- 20belt(13,14), 40slopes(12), 20deck(13,14), 40CT(12); 1x1-100/45, 3x1-65/50, 6x1-47/40(12), 7x1-47/40(13,14), 2x1-450TT(13,14)
			12	D'Iberville	1894		
			13	Cassini	1895		
	Dunois	2	14	Casabianca	1896		889t, 78.0x8.4x3.9m, 8b,2vte, 7500hp, 21.7-22kts, 137p;
			15	Dunois	1898		

			16	La Hire	1899		steel- 25belt, 10deck, 50CT; 6x1-65/50, 6x1-47/40	
DD	Durandal	3	1	Durandal	1899		296(1,2)-306(3)t, 57.6x6.3x3.2m, 2b,2vte, 4800hp, 26kts, 52p; 1x1-65/50, 6x1-47/40, 2x1-380TT	
			2	Hallebarde	1899			
			3	Fauconneau	1900			
	Framée	3	4	Yatagan	1900		314t, 58.1x6.3x3.0m, 4b,2vte, 4800-5200hp, 26kts, 48p; 1x1-65/50, 6x1-47/40, 2x1-380TT	
			5	Pique	1901			
			6	Epée	1901			
	Pertuisane	4	7	Pertuisane	1902		344t, 57.6x6.3x3.2m, 2b,2vte, 4800hp, 26kts, 52p; 1x1-65/50, 6x1-47/40, 2x1-380TT	
			8	Escopette	1903			
			9	Flamberge	1903			
			10	Rapière	1903			
	Arquebuse	20	11	Carabine	1903		298t, 58.2x6.4x3.2m, 2b,2vte, 6300hp, 28kts, 60p; 1x1-65/50, 6x1-47/40, 2x1-380TT	
			12	Sarbacane	1903			
			13	Arquebuse	1903			
			14	Arbalète	1903			
			15	Mousquet	1903			
			16	Javeline	1903			
			17	Sagaie	1903			
			18	Épieu	1903			
			19	Harpon	1903			
			20	Fronde	1903			
			21	Francisque	1904			
			22	Sabre	1904			
			23	Dard	1904			
			24	Baliste	1904			
			25	Mousqueton	1904			
			26	Arc	1904			
			27	Pistolet	1903			
			28	Bélier	1904			
			29	Catapulte	1903			
			30	Bombarde	1903			
				31	Styler	1907		
				32	Tromblon	1907		
				33	Pierrier	1908		
				34	Obusier	1907		
				35	Mortier	1908		

Claymore	13	36	Claymore	1906		350t, 58.5x6.5x3.0m, 2b,2vte, 6800hp, 28kts, 60p; 1x1-65/50, 6x1-47/50, 2x1-450TT
		37	Carquois	1908		
		38	Trident	1909		
		39	Fleuret	1908		
		40	Coutelas	1908		
		41	Cognée	1908		
		42	Hache	1909		
		43	Massue	1909		
Branlebas	8	44	Sabretache	1908		339t, 57.9x6.6x2.4m, 2b,2vte, 6800hp, 27.5kts, 60p; 1x1-65/50, 6x1-47/50, 2x1-450TT
		45	Oriflamme	1908		
		46	Étendard	1909		
		47	Fanion	1909		
		48	Sape	1908		
		49	Gabion	1908		
		50	Branlebas	1908		
		51	Fanfare	1908		
Spahi	1	52	Carabinier	1909		550t, 67.0x6.5x2.4m, 4b,2vte, 7500hp, 28kts, 77-79p; 6x1-65/50, (1+2x1)-450TT
Chasseur	1	53	Chasseur	1909		520t, 64.2ppx6.5x3.1m, 4b,3st, 7200hp, 28kts, 77-79p; 6x1-65/50, (1+2x1)-450TT
Balny	3	1-3	Balny, Capitaine Cuny, Capitaine Mehl	1886		65t, 40.7x3.3x1.2m, 1b,1cr, 580hp, 19kts, 22p; 2x5-37/20, 2-350TT
		4	Coureur	1888		125(4)-131(5,6)t, 44.9(4)-45.1(5,6)x4.3(4)-4.4(5,6)x1.4m, 2b,2vcr(4)-2b,2vte(5,6), 1500(4)-1750(5,6)hp, 23.5kts; 2x1-47/40, 2-350TT
			5	Véloce		
Ouragan	3	7	Téméraire	1889		177t, 46.7x4.8x1.8m, 2b,1vqe, 1400hp, 16kts, 29-32p; 2x1-47/40, 4x1-350TT
		8	Aventurier	1889		
		9	Défi	1889		
Agile	6	10	Agile	1889		119(10-13)-129(14)t, 43.6(10-13)-44.2(14)x4.6x1.1m, 1b,1vte(10)-2b,1vte(11-14), 1100hp, 27kts; 3x5-37/20, 3x1-350TT(10-12), (1+1x1)-380TT(13,14)
		11	Eclaire	1891		
		12	Kabyle	1892		
		13	Orage	1892		
Avant-Garde	4	14	Tourbillon	1894		127(15)-129(16-18)t, 41.9ppx4.5x1.3m, 2b,2vte, 1750hp, 21kts, 27p; 2x1-47/40, (1+1x1)-350TT
		15	Turco	1892		
		16	Dragon	1892		
		17	Grenadier	1892		
		18	Lancier	1893		

TB	Corsaire	1	19	Corsaire	1893		168t, 50.5x4.5x1.7m, 2b,2vte, 2500hp, 25.5kts; 2x5-37/20, 2x1-380TT
	Mousquetaire	1	20	Mousquetaire	1893		123t, 48.0x4.7x1.3m, 2b,2vte, 2100hp, 24.5kts; 2x5-37/20, 2x1-450TT
	Chevalier	1	21	Chevalier	1894		135t, 43.8x4.5x1.5m, 2b,2vte, 2200hp, 24.5kts; 2x5-37/20, 2x1-450TT
	Argonaute	2	22	Argonaute	1894		129t, 42.9x4.5x1.7m, 2b,2vte, 2000hp, 23.5kts, 27p; 2x1-47/40, (1+1x1)-380TT
			23	Tourmente	1894		
	Averne	2	24	Averne	1894		131t, 43.9x4.6x1.3m, 2b,2vte, 1750hp, 23.5kts; 2x1-47/40, (1+1x1)-380TT
			25	Dauphin	1894		
	Filibustier	2	26	Ariel	1895		123t, 42.0x4.5x1.7m, 2b,2vte, 2000hp, 23.5kts; 2x1-47/40, (1+1x1)-380TT
			27	Aquilon	1896		
	Forban	1	28	Forban	1896		150t, 44.0x4.6x1.4m, 2b,2vte, 3260hp, 29kts, 29p; 2x1-37/20, 2x1-380TT
	Mangini	1	29	Mangini	1897		140t, 45.0ppx4.7x1.5m, 2b,2vte, 2100hp, 24kts, 27p; 2x1-47/40, (1+1x1)-380TT
	Cyclone	5	30	Cyclone	1899		150(30)-165(31-34)t, 46.4(30)-46.6(31-34)x4.7(30)-4.8(31-34)x1.5m, 2b,2vte, 4200(30)-3800(31-34)hp, 29kts; 2x1-47/40, 1x2-380TT
			31	Bourrasque	1902		
			32	Rafale	1902		
33			Borée	1901			
34			Tramontane	1902			
Takou	1	35	Takou	1898		284t, 59.0x6.4x2.6m, 4b,2vte, 5000hp, 27kts, 57p; 4x1-47/40, 2x1-37/20, 2x1-380TT	
Mistral	6	36	Mistral	1901		183t, 45.0x5.2x1.6m, 2b,2vte, 4200hp, 26kts, 30p; 24belt, 9deck; 2x1-47/40, 2x1-380TT	
		37	Siroco	1901			
		38	Simoun	1901			
		39	Typhon	1903			
		40	Trombe	1902			
		41	Audacieux	1900			
No29	1	1	No56	1882	No picture	11t, 18.3x2.3x0.6m, 1b,1cr, 12kts, 12p; 1-350TT	
No75	3	2-4	No123-125	1889	No picture	53t, 35.0ppx3.4x0.9m, 1b,1vcr, 525hp, 20kts, 16p; 2x5-37/20, 2-380TT	
No126	3	5-7	No127-129	1889-1890	No picture	78t, 36.0x3.9x1.2m, 1b,1vcr, 900hp, 21kts, 21p; 2x5-37/20, 2x1-380TT	
No130	14	8-21	No130-132, 134-144	1890-1892		52t, 34.0ppx3.5x0.9m, 1b,1vte, 720hp, 20kts, 18p; 2x1-37/20, 2x1-380TT	
		22-		1891-		78t, 35.9ppx3.9x1.2m, 1b,1vte(22-35,45,46)-2b,1vte(36-44),	

No145	25	46	No145-149, 152-171	1893		1000hp, 21kts, 22-23p; 2x5-37/20, (1+1x1)-380TT
No172	29	47-75	No172-200	1892-1895		78t, 35.9pp(47-66)-36.9pp(67-75)x3.9x1.2m, 2b,1vte(47-56,62-66)-1b,1vte(57-61,67-75), 1350hp, 22(47-69)-23(70-75)kts, 22-23p; 2x5-37/20, (1+1x1)-380TT
No201	90	76-165	No201-204, 206-233, 235-241, 6S, 243, 7S, 10S-14S, 250-253, 15S, 16S, 256-260, 1M, 2M, 263-270, 3M, 4M, 273-276, 8S, 278-283, 17S-19S, 5M, 288, 289, 6M, 20S, 21S, 9S	1897-1904		83-90t, 37.0x4.2x1.2m, 2b,1vte(76-115,117-165)-2b,1st(116), 1500-1800(76-115,117-165)-1900(116)hp, 24(76-150)-26(151-165)kts, 23p; 2x5-37/20, (1+1x1)-380TT
No293	1	166	No293	1904		94t, 39.5x4.1x1.3m, 2b,3st, 2000hp, 26kts; 2x5-37/20, (1+1x1)-380TT
No294	1	167	No294	1904		100t, 38.5x4.0x1.4m, 2b,2st, 1800hp, 24kts; 2x5-37/20, (1+1x1)-380TT
Libellule	1	168	Libellule	1905		39t, 36.4ppx3.4x1.9m, 1b,1st, 1000hp, 13kts; 1x1-380TT
		169	No295	1906		
		170	No296	1906		
		171	No297	1906		
		172	No298	1906		
		173	No299	1906		
		174	No300	1908		
		175	No301	1906		
		176	No302	1906		
		177	No303	1905		
		178	No304	1906		
		179	No305	1906		
		180	No306	1905		
		181	No307	1905		
		182	No308	1906		
		183	No309	1906		
		184	No310	1906		
		185	No311	1906		
		186	No312	1905		
		187	No313	1905		
		188	No314	1906		
		189	No315	1905		
		190	No316	1906		
		191	No317	1906		
		192	No318	1907		
		193	No319	1907		
		194	No320	1907		
		195	No321	1907		

TB2cl

No295

75









196	No322	1906
197	No323	1906
198	No324	1906
199	No325	1906
200	No326	1907
201	No327	1907
202	No328	1907
203	No329	1907
204	No330	1908
205	No331	1908
206	No332	1907
207	No333	1907
208	No334	1907
209	No335	1907
210	No336	1907
211	No337	1908
212	No338	1906
213	No339	1906
214	No340	1907
215	No341	1906
216	No342	1906
217	No343	1906
218	No344	1906
219	No345	1906
220	No346	1906
221	No347	1906
222	No348	1906
223	No349	1906
224	No350	1906
225	No351	1906
226	No352	1907
227	No353	1907
228	No354	1907
229	No355	1906
230	No356	1907
231	No357	1907
232	No358	1907
233	No359	1906
234	No360	1906
235	No361	1906
236	No362	1906



103-105t, 38.0x4.4x1.9m, 2b,1vte, 1800-2000hp, 26kts, 23p;
2x5-37/20, (1+1x2)-450TT





237	No363	1906
238	No364	1906
239	No365	1908
240	No366	1909
241	No367	1907
242	No368	1907
243	No369	1908

SUBMARINES

SS	Sirène	4	1	Sirène	1901		157/213t, 32.5x3.9x2.5m, 1b,1vte/em, 250/100hp, 9.8/5.8kts, 13p, 30m; 4-450TC
			2	Triton	1901		
			3	Espadon	1902		
			4	Silure	1902		
	Farfadet	1	5	Follet	1902		185/202t, 41.3x2.9x2.6m, 1em, 183hp, 6.1/4.3kts, 16p, 30m; 4-450TC
	Français	2	6	Français	1902		147/160t, 36.7x2.7x2.8m, 1em, 307hp, 10.1/8.3kts, 13p, 30m; 1-450TT, 2-450TC
			7	Algerien	1902		
	Naïade	20	8-27	Naïade, Protée, Perle, Esturgeon, Bonite, Thon, Souffleur, Dorade, Lynx, Ludion, Loutre, Castor, Phoque, Otarie, Méduse, Oursin, Grondin, Anguille, Alose, Truite	1904-1905		71/74t, 23.7x2.2x2.6m, 1pe/em, 57/95hp, 7.2/6kts, 12p, 30m; 2-450TC
	X	1	28	X	1905		168/179t, 37.0x3.1x2.4m, 2pe/em, 260/230hp, 8.4/6.1kts, 15p, 30m; 1-450TT, 3-450TC
	Z	1	29	Z	1905	No picture	202/222t, 41.3x3.0x2.8m, 1d/em, 190/hp, 9/7.1kts, 16p, 30m; 2-450TT
	Aigrette	2	30	Aigrette	1905		178/253t, 35.9x4.0x2.6m, 1d/em, 150/130hp, 9.3/6.2kts, 14p, 30m; 4-450TC
			31	Cigogne	1905		
	Émeraude	4	32	Émeraude	1908		392/425t, 44.9x3.9x3.6m, 2d/em, 600/200hp, 11.5/9.2kts, 21p, 40m; 6-450TT
			33	Opale	1908		
			34	Rubis	1909		
			35	Saphir	1909		
	Pluviôse	10	36	Pluviôse	1908		398/550t, 51.1x4.9x3.0m, 2b,2vte/em, 700/450hp, 12/8kts, 24p, 40m; 1-450TT, 6-450TC
			37	Ventôse	1908		
			38	Germinal	1908		
			39	Floréal	1909		
			40	Prairial	1909		
			41	Messidor	1909		
			42	Vendémiaire	1908		
			43	Papin	1909		
			44	Fresnel	1909		
45			Monge	1909			

Circé	2	46	Circé	1909		351/491t, 47.1x4.9x3.0m, 2d/em, 630/460hp, 11.9/7.7kts, 22p, 40m; 1x1-47/50, 6-450TC
		47	Calypso	1909		

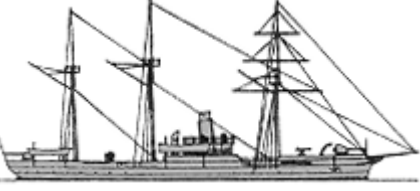
OTHER FIGHTING SHIPS

PG	Fusée	2	1	Fusée	1885		1073-1124t, 50.3x9.9x3.2m, 3b,2vc, 1500hp, 12.5kts, 89p; compound(2)-steel(1)- 240belt, 50deck, 200barbette; 1x1-240/29, 1x1-90/28, 4x5-37/20
			2	Mitraille	1888		
	Achéron	4	3	Achéron	1888		1690(3,4)-1767(5,6)t, 55.2(3,4)-58.7(5,6)x12.3x3.6m, 4b,2hc, 1600hp, 11.6-13kts, 110p; compound- 200belt, 50deck, 200turret; 1x1-274/29, 1x1-139/28(5,6), 2x1-100/26(3), 3x1-100/26(4), 2x1-47/40, 4x5-37/20(3,4), 7x5-37/20(5,6)
			4	Cocyte	1890		
			5	Phlégéon	1892		
			6	Styx	1892		
	Surprise	3	7	Surprise	1896		617-637t, 56.0-56.3ppx7.9-8.0x3.7m, 2b,1hte, 900hp, 13kts, 99p; 2x1-100/45, 4x1-65/50, 4x1-37/20
			8	Décidée	1898		
			9	Zélée	1900		
	PR	Vigilante	3	1	Argus	1900	No picture
2				Vigilante	1900		
3				Peï-Ho	1901		
	Doudart de la Grée	1	4	Doudart de la Grée	1909		183t, 54.4x6.7x1.0m, 2b,2vte, 900hp, 14kts, 66p; 6x1-37/20

MINE WARFARE SHIPS

ATL	-	1	1	Orient			385t
-----	---	---	---	--------	--	--	------

[home](#)[World navies yesterday](#)[1910](#)

Germany 01 January 1910

BATTLESHIPS

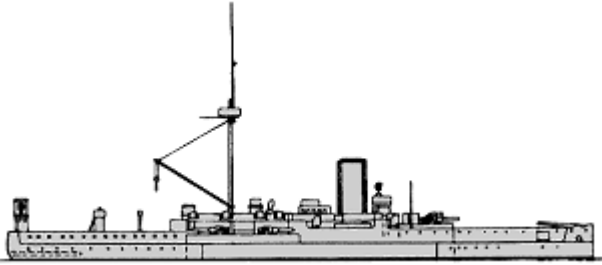
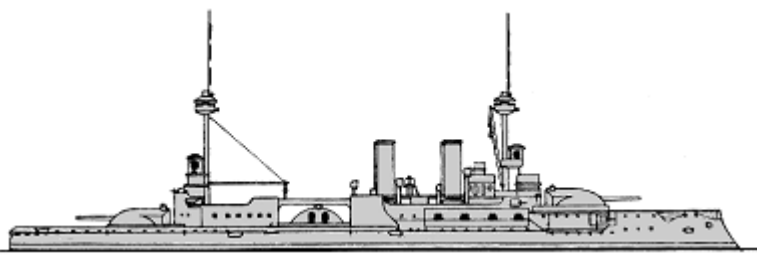
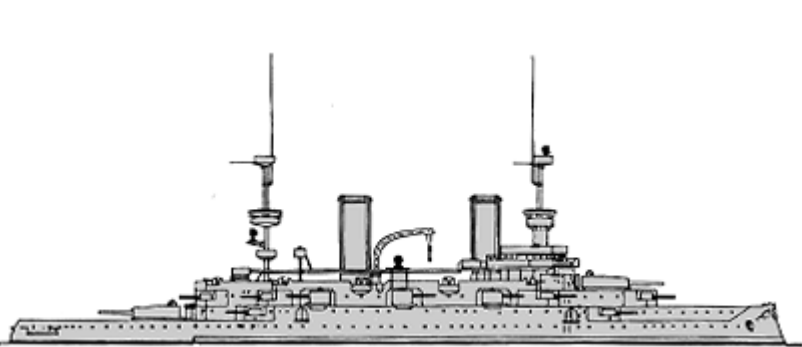
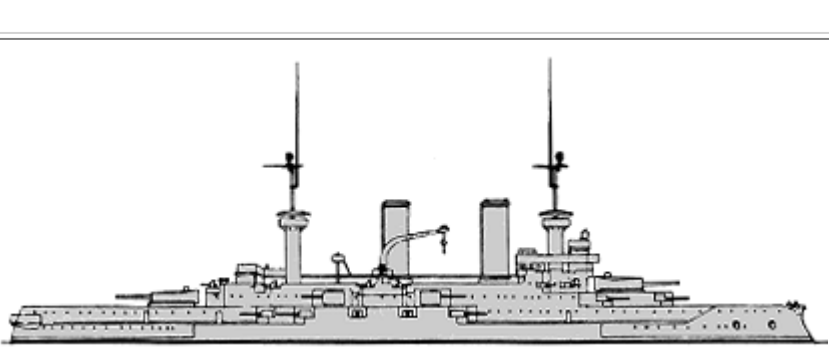
Sachsen	1	Sachsen	1878		7742-7938t, 98.2x18.4x6.5m, 8b,2hc, 6201-6454hp, 14.2-15.7kts, 317p; 254belt, 75deck, 254barbettes/citadel, 200CT; 6x1-263/20, 8x1-88/27, 6x1-87/22, 8x5-37/20, 2-450TT, 3-350TT
	2	Bayern	1881		
	3	Baden	1883		
Kurfürst Friedrich Wilhelm	4	Kurfürst Friedrich Wilhelm	1894		10670t, 115.7x19.5x7.9m, 12b,2vte, 10000hp, 16.5kts, 568p; compound(4,6); 400belt, 60deck, 300barbettes, 300CT; 2x2-283/37, 1x2-283/32, 8x1-105/32, 8x1-99/27, 3-450TT
	5	Brandenburg	1893		
	6	Weissenburg	1894		
	7	Wörth	1893		
Kaiser Friedrich III	8	Kaiser Friedrich III	1898		11785t, 125.3x20.4x8.3m, 12b,3vte(8,9)-10b,3vte(10-12), 13000hp, 17.5kts, 651p; 300belt, 65deck, 250turrets, 250CT; 2x2-238/37, 14x1-149/37(8), 18x1-149/37(9-12), 14x1-88/27(8), 12x1-88/27(9-12), 5-450TT(8), 6-450TT(9-12)
	9	Kaiser Wilhelm II	1900		
	10	Kaiser Wilhelm der Grosse	1901		
	11	Kaiser Karl der Grosse	1902		
	12	Kaiser Barbarossa	1901		
BB Wittelsbach	13	Wittelsbach	1902		12798t, 126.8x20.8x8.0m, 12b,3vte, 14000hp, 17.5kts, 683p; 225belt, 50deck, 250turrets, 250CT; 2x2-238/37, 18x1-149/37, 12x1-88/27, 6-450TT
	14	Wettin	1902		
	15	Zähringen	1902		
	16	Schwaben	1904		
	17	Mecklenburg	1903		

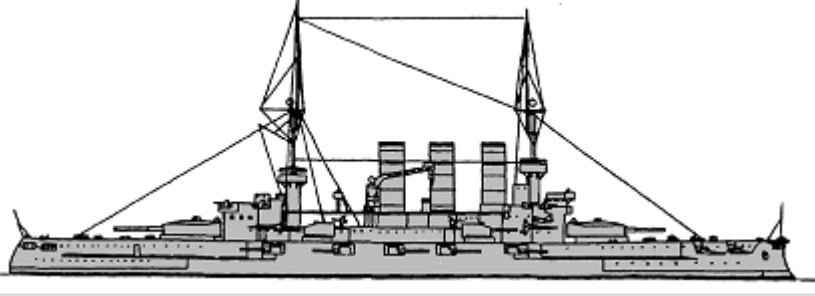
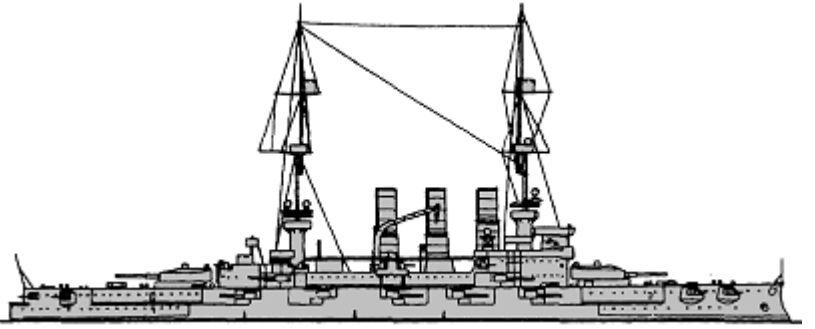
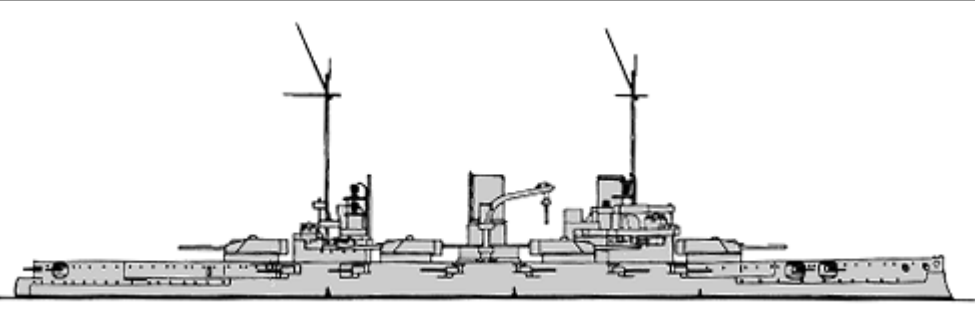
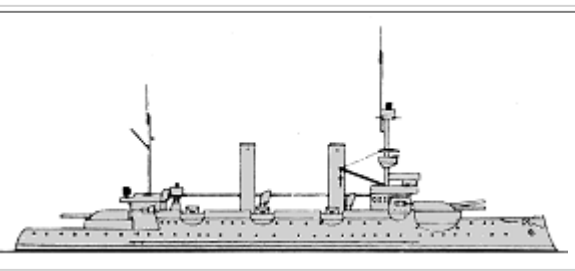
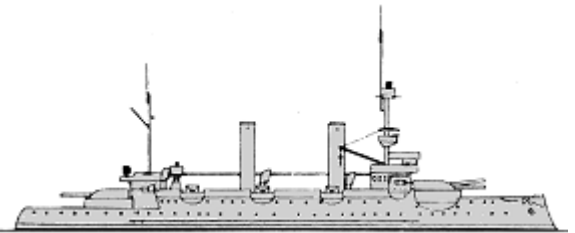
Braunschweig	18	Braunschweig	1904		14394t, 127.7x25.6x8.1m, 14b,3vte, 17000hp, 18.2kts, 743p; 225belt, 40deck, 250turrets, 300CT; 2x2-283/37, 14x1-173/37, 18x1-88/32, 6-450TT	
	19	Elsass	1904			
	20	Hessen	1905			
	21	Preussen	1905			
	22	Lothringen	1906			
Deutschland	23	Deutschland	1906		13994t, 127.6x22.2x8.3m, 12b,3vte, 20540hp, 19.1kts, 743p; 225(23)-240(24-27)belt, 40deck, 280turrets, 300CT; 2x2-283/37, 14x1-173/37, 20x1-88/32, 6-450TT	
	24	Hannover	1907			
	25	Pommern	1907			
	26	Schlesien	1908			
	27	Schleswig-Holstein	1908			
Nassau	28	Nassau	1909		20535t, 146.1x26.9x8.8m, 12b,3vte, 22000hp, 19.5kts, 1008p; 300belt, 80deck, 280turrets, 400CT; 6x2-283/42, 12x1-149/42, 16x1-88/45, 6-450TT	
	29	Westfalen	1909			
BC	Siegfried	1	Siegfried	1890		4236-4436t, 86.1x14.9x5.7m, 8b,2vte, 4700-5300hp, 15kts, 307p; compound; 240belt, 30(1-3,5)-50(4,6)deck, 200barbettes, 80(1-3,5)-160(4,6)CT; 3x1-238/32, 10x1-88/27, 3-450TT, 1-350TT
		2	Beowulf	1892		
		3	Frithjof	1893		
		4	Heimdall	1894		
		5	Hildebrand	1893		
		6	Hagen	1894		
Odin	Odin	7	Odin	1896		4236-4436t, 86.2x15.4x5.6m, 8b,2vte, 5000(7)-5600(8)hp, 15.5kts, 307p; 220belt, 70deck, 200barbettes, 120CT; 3x1-238/32, 10x1-88/27, 4-450TT
		8	Ägir	1896		

CRUISERS

						11461t, 127.0x20.4x8.5m, 12b,3vte, 13500hp, 18.7kts, 621p; 200belt,
--	--	--	--	--	--	---

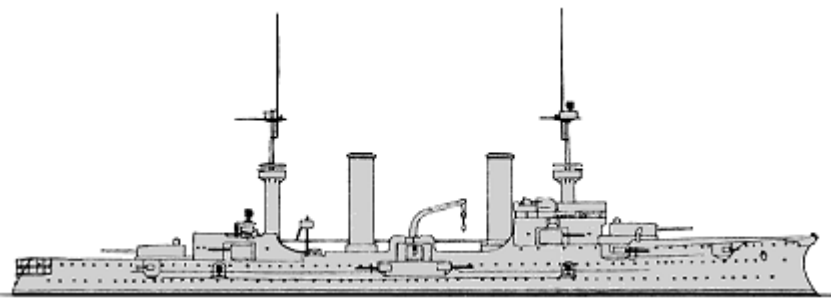
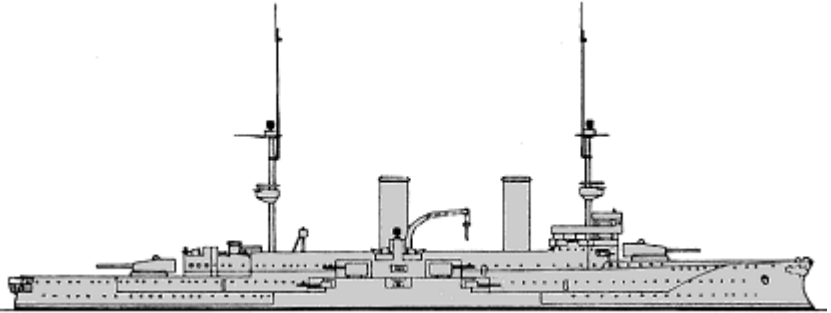
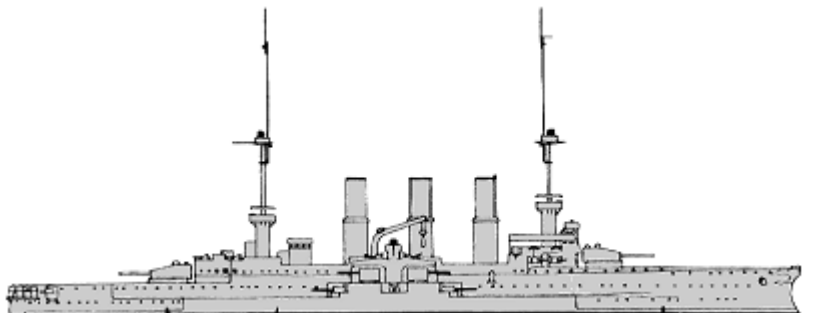
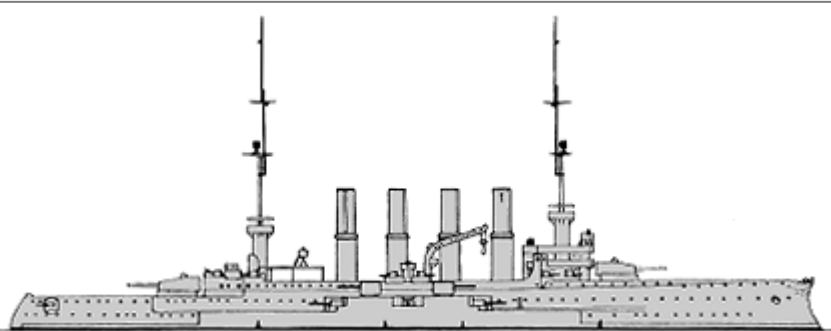
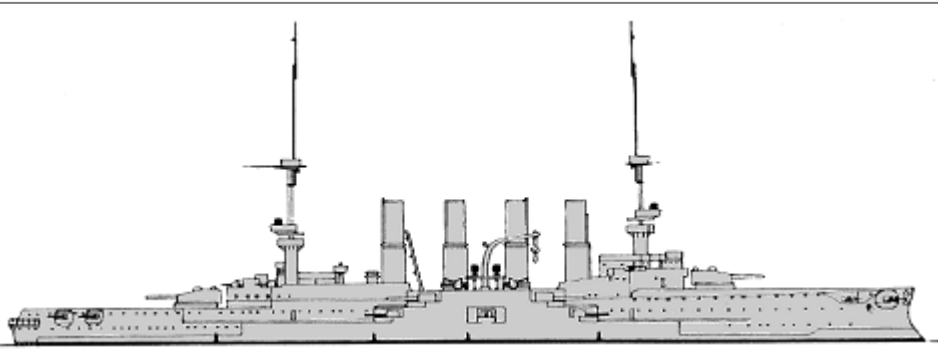
CA	Fürst Bismarck	1	1	Fürst Bismarck	1900		30deck, 200turrets, 200CT; 2x2-238/37, 12x1-149/37, 10x1-88/27, 6-450TT
	Prinz Heinrich	1	2	Prinz Heinrich	1902		9806t, 126.5x19.6x8.1m, 14b,3vte, 15000hp, 20kts, 567p; 100belt, 40deck, 150turrets, 150CT; 2x1-238/37, 10x1-149/37, 10x1-88/27, 4-450TT
	Prinz Adalbert	2	3	Prinz Adalbert	1904		9875t, 126.5x19.6x7.8m, 14b,3vte, 17000hp, 20.5kts, 586p; 100belt, 80deck, 150turrets, 150CT; 2x2-209/37, 10x1-149/37, 12x1-88/32, 4-450TT
			4	Friedrich Carl	1903		
	Roon	2	5	Roon	1906		10266t, 127.8x20.2x7.8m, 16b,3vte, 19000hp, 21kts, 633p; 100belt, 60deck, 150turrets, 150CT; 2x2-209/37, 10x1-149/37, 14x1-88/32, 4-450TT
	6		Yorck	1905			
	Scharnhorst	2	7	Scharnhorst	1907		12985t, 144.6x21.6x8.4m, 18b,3vte, 26000hp, 22.5kts, 764p; 150belt, 60deck, 170turrets, 200CT; (2x2+4x1)-209/37, 6x1-149/37, 18x1-88/32, 4-450TT
			8	Gneisenau	1908		

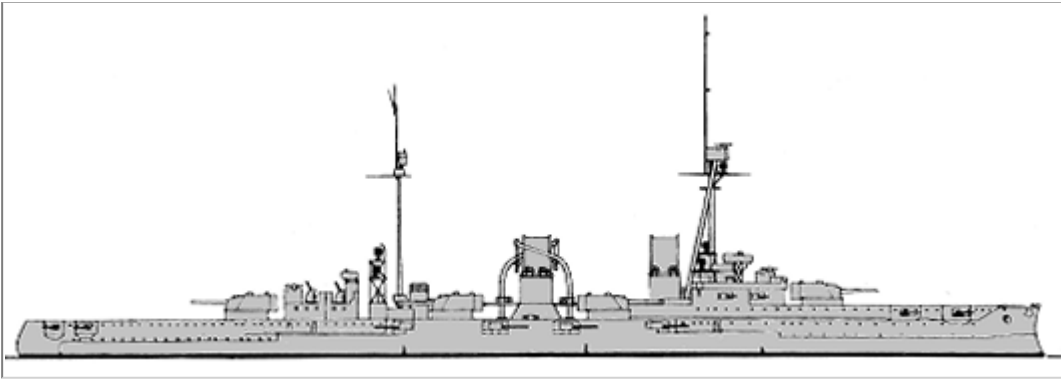
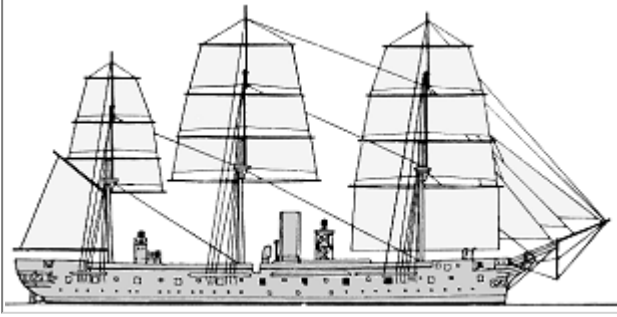
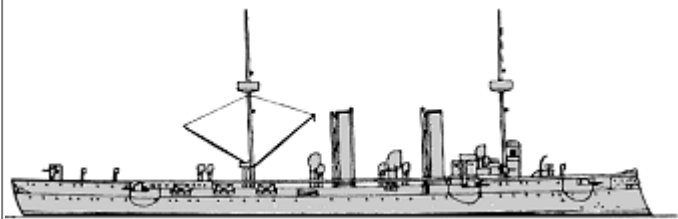
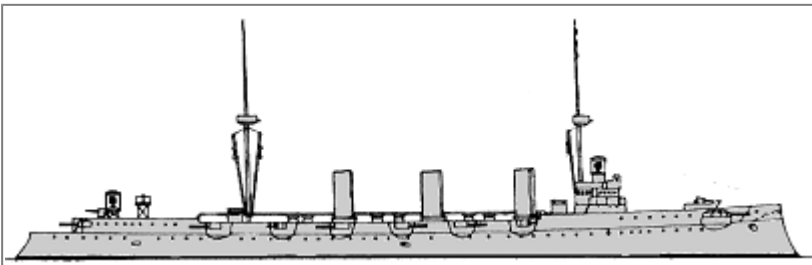
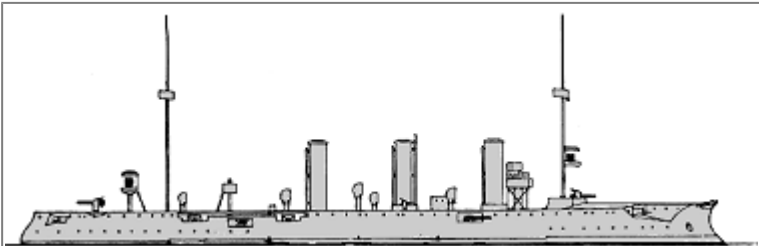
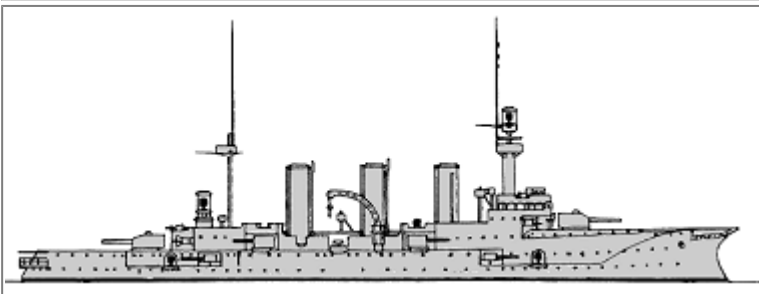

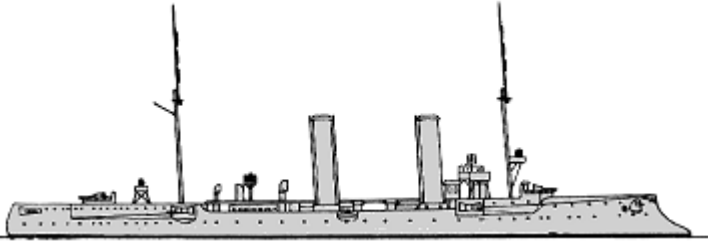
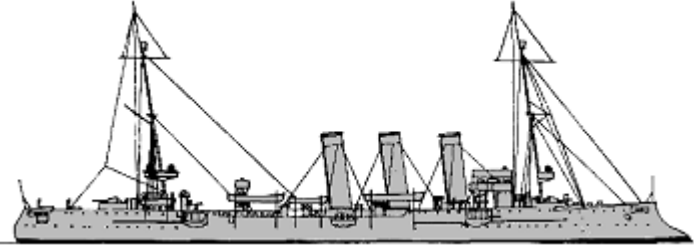
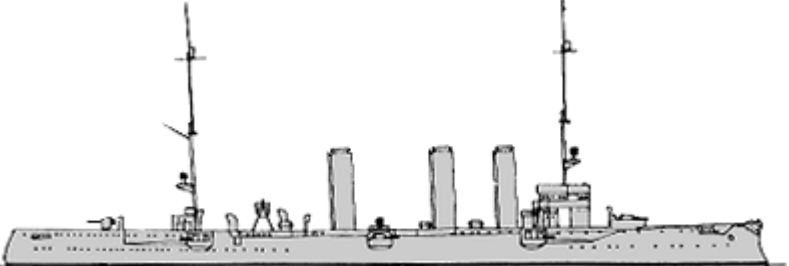
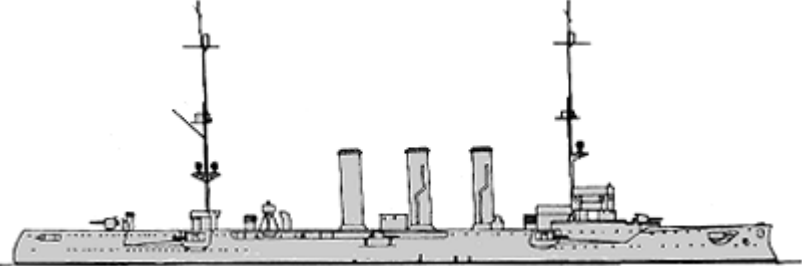
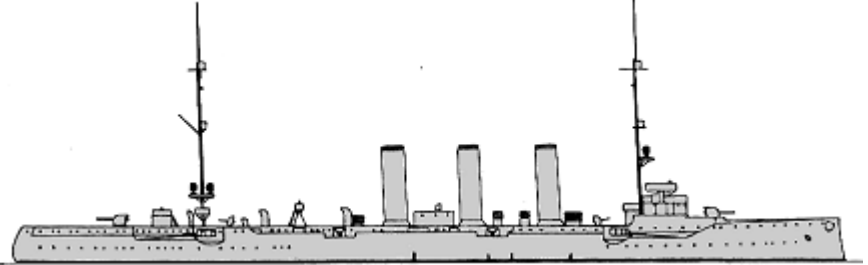
						17500t, 161.8x24.5x8.8m, 18b,3vte, 32000hp, 24.5kts, 853p; 180belt, 70deck, 180turrets, 250CT; 6x2-209/42, 8x1-149/42, 16x1-88/45, 4-450TT	
	Bismarck	1	1	Moltke	1878		2994t, 82.0x13.7x6.3m, 4b,1hse, 2500hp, 12.5kts, 404p; 10x1-149/22, 2x1-88/27, 6x5-37/20
	Irene	2	2	Irene	1888		5027t, 103.7x14.2x7.6m, 4b,2hc, 8000hp, 18kts, 365p; compound; 75slopes, 50deck, 50CT; 4x1-149/28, 8x1-105/32, 6x1-50/37, 3-350TT
			3	Prinzess Wilhelm	1889		
	Kaiserin Augusta	1	4	Kaiserin Augusta	1892		6381t, 123.2x15.6x7.4m, 8b,3vte, 12000hp, 21kts, 430p; 70slopes, 50deck, 50CT; 14x1-149/32, 8x1-88/27, 4x5-37/20, 1-350TT
	Gefion	1	5	Gefion	1894		4275t, 110.4x13.2x6.5m, 6b,2vte, 9000hp, 19kts, 212p; steel; 25slopes, 30deck, 30CT; 10x1-105/32, 6x1-50/37, 2x1-450TT
	Victoria Louise	5	6	Victoria Louise	1899		6491(6-8)-6705(9,10)t, 110.6x17.4(6-8)-17.6(9,10)x6.8-7.3m, 8b,3vte(6-8,10)-12b,3vte(9), 10000hp, 19.5(6-8)-18.5(9,10)kts, 477p; 100slopes, 40deck, 100turrets, 150CT; 2x1-209/37, 6x1-149/37(6-8,10), 8x1-149/37(9), 3x1-88/32(6-8,10), 11x1-88/27(6-8,10), 10x1-88/27(9), 3-450TT
			7	Hertha	1898		
			8	Freya	1898		
			9	Vineta	1899		
			10	Hansa	1899		

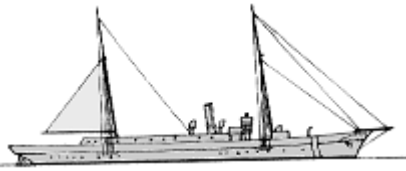
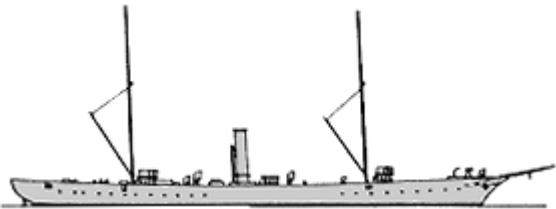
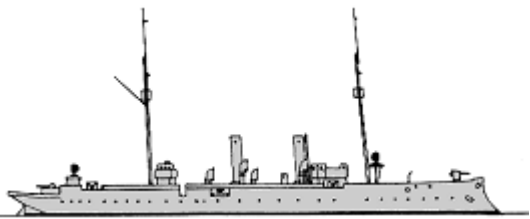
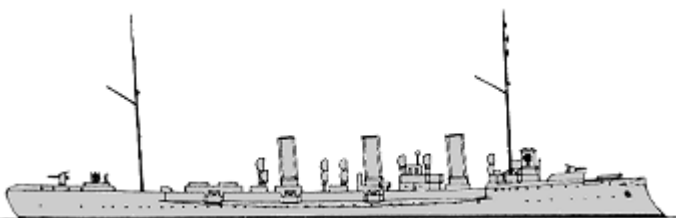
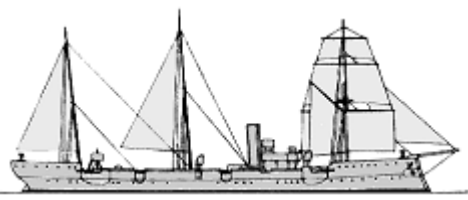
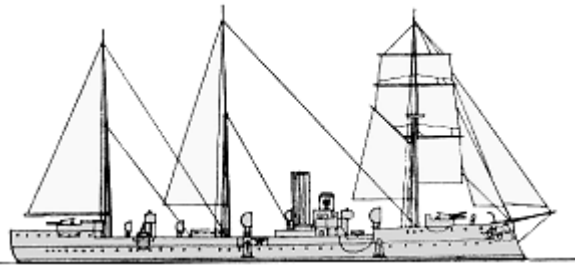
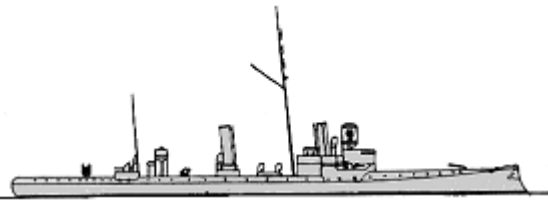

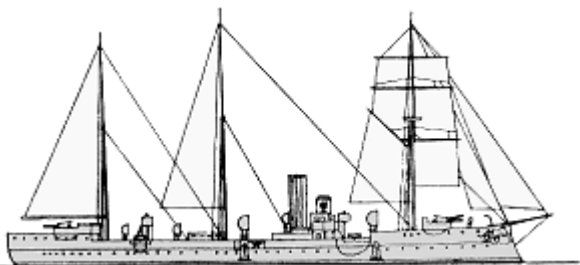
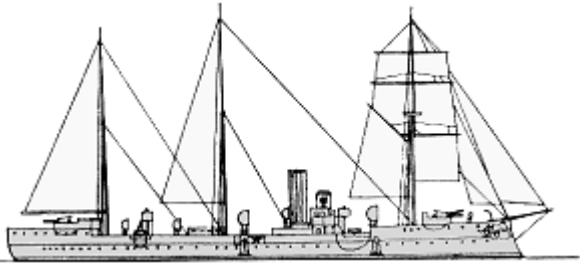
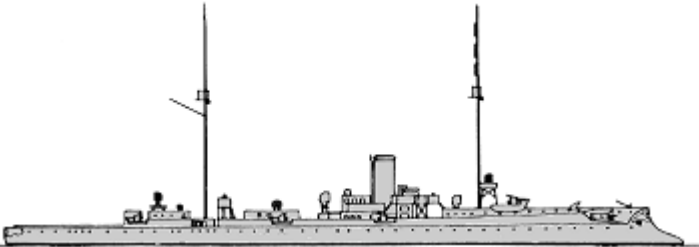

CL	Gazelle	10	11	Gazelle	1900		<p>2963(11,12)-3082(13-17)-3180(18-20)t, 105.0(11,12,18-20)-105.1(13-17)x12.2(11-17)-12.4(18-20)x5.5(11,12,18-20)-5.4(13-17)m, 8b,2vte(11,12)-10b,2vte(13)-9b,2vte(14-20), 6000(11)-8110(12)-9020(13-17)-8580(18-20)hp, 20(11)-22.1(12)-21.8(13-17)-21.5(18-20)kts, 249(11-17)-259(18-20)p; 50slopes, 25deck, 50shields, 80CT; 10x1-105/37, 3-450TT(11), 2-450TT(12-20)</p>
			12	Niobe	1900		
			13	Nymphe	1900		
			14	Thetis	1901		
			15	Ariadne	1901		
			16	Amazone	1901		
			17	Medusa	1901		
			18	Frauenlob	1903		
			19	Arcona	1903		
			20	Undine	1904		
Bremen	7	28	Bremen	1904		<p>3816(28-30,32-34)-3661(31)t, 111.1x13.3x5.6m, 10b,2vte(28-30,32-34)-10b,2st(31), 11750(28-30,32-34)-14400(31)hp, 23kts, 288p; 80slopes, 35deck, 50shields, 100CT; 10x1-105/37, 2-450TT</p>	
		29	Hamburg	1904			
		30	Berlin	1905			
		31	Lübeck	1905			
		32	München	1905			
		33	Leipzig	1906			
		34	Danzig	1907			
Königsberg	4	35	Königsberg	1907		<p>3814(35)-3902(36)-40002(37)-3822(38)t, 115.3(35)-117.4(36-38)x13.2(35)-13.3(36-38)x5.3(35)-5.2(36)-5.4(37)-5.1(38)m, 11b,2vte(35-37)-11b,4st(38), 13200(35-37)-13500(38)hp, 23(35-37)-24(38)kts, 322p; 80slopes, 30deck, 50shields, 100CT; 10x1-105/37, 8x1-52/52(36-38), 2-450TT</p>	
		36	Nürnberg	1908			
		37	Stuttgart	1908			
		38	Stettin	1907			
Dresden	2	39	Dresden	1908		<p>4268t, 118.3x13.5x5.5m, 12b,4st(39)-12b,2vte(40), 15000(39)-13500(40)hp, 24(39)-23.5(40)kts, 361p; 80slopes, 30deck, 50shields, 100CT; 10x1-105/37, 8x1-52/52, 2-450TT</p>	
		40	Emden	1909			
Kolberg	1	41	Mainz	1909		<p>4889t, 130.5x14.0x5.6m, 15b,2st, 20200hp, 26kts, 367p; 80slopes, 40deck, 50shields, 100CT; 12x1-105/42, 4x1-52/52, 2-450TT, 100mines</p>	
Grille	1	1	Grille	1858		<p>491t, 56.9x7.4x3.2m, 2b,1hc, 760hp, 14.4kts, 70p; 1x1-125/21, 2x1-79/25, 6x5-37/20</p>	

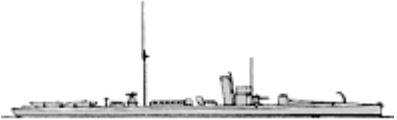
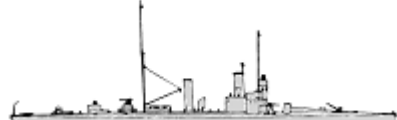
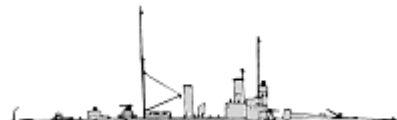
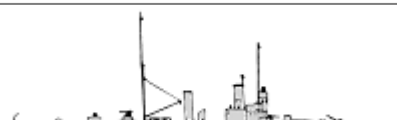

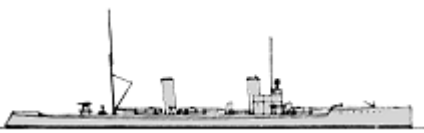

							
	Zieten	1	2	Zieten	1876		1170t, 79.4x8.6x4.6m, 6b,2hc, 2000hp, 16kts, 94p; 6x1-50/37
	Blitz	2	3	Blitz	1883		1486t, 78.4x9.9x4.4m, 8b,2hc, 2700hp, 15.6kts, 134p; 6x1-88/27, (2x1+1)-350TT
			4	Pfeil	1884		
	Greif	1	5	Greif	1887		2266t, 102.6x9.8x4.3m, 8b,2hc, 5795hp, 19kts, 170p; 2x1-105/32, 6x1-88/32, 4x5-37/20
	Schwalbe	1	6	Sperber	1889		1359t, 66.9x9.4x4.7m, 4b,2hc, 1500hp, 13.5kts, 117p; 8x1-105/32, 5x5-37/20
CLL	Bussard	2	7	Bussard	1890		1868t, 82.6x10.2x5.6m, 4b,2hte, 2800hp, 15.5kts, 161p; 8x1-105/32, 5x5-37/20, 2x1-350TT
			8	Falke	1891		
	Meteor	2	9	Meteor	1891		1078(9)-1117(10)t, 79.9x9.6x4.5m, 4b,2vte, 4500(9)-5000(10)hp, 19(9)-19.5(10)kts, 115p; steel; 25slopes, 15deck, 30CT; 4x1-88/27, 3-350TT
			10	Comet	1893		
	Seeadler	3	11	Seeadler	1892		1864t, 82.6x10.5x5.4m, 4b,2hte, 2800hp, 15.5kts, 161p; 8x1-105/32, 5x5-37/20, 2x1-350TT
			12	Condor	1892		

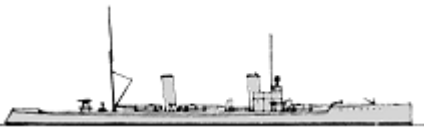
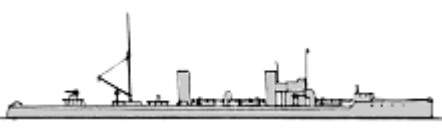
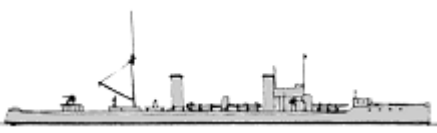





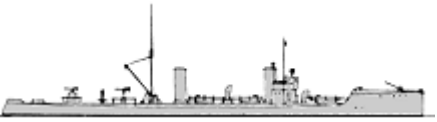
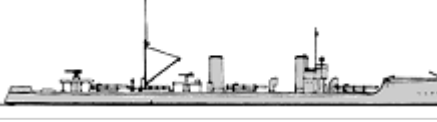

			13	Cormoran	1893		
Geier	1		14	Geier	1895		1918t, 83.9x10.6x5.2m, 4b,2hte, 2880hp, 15.5kts, 161p; 8x1-105/32, 5x5-37/20, 2x1-450TT
Hela	1		15	Hela	1896		2082t, 105.0x11.0x4.6m, 8b,2vte, 6000hp, 20kts, 178p; steel; 25slopes, 20deck, 30CT; 2x1-88/27, 6x1-50/37, 3-450TT

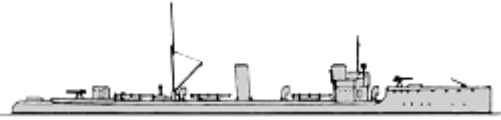
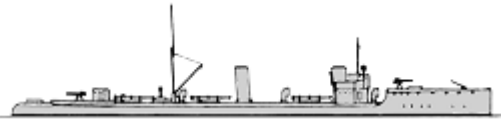
TORPEDO SHIPS

D1	2	1	D1	1887		300t, 56.1x6.6x3.4m, 2b,1vte, 2000hp, 20.6kts, 46p; 3x1-50/37, (1+2x1)-350TT
		2	D2	1887		
D3	2	3	D3	1888		300t, 57.6x6.8x3.2m, 2b,1vte, 2200hp, 20.3kts, 46p; 3x1-50/37, (1+2x1)-350TT
		4	D4	1888		
D5	2	5	D5	1889		406t, 59.6x7.4x3.5m, 2b,1vte, 3200hp, 22.6kts, 46p; 3x1-50/37, (1+2x1)-350TT
		6	D6	1889		
D7	2	7	D7	1891		410t, 59.7x7.4x3.4m, 2b,1vte, 3600hp, 22.5kts, 46p; 3x1-50/37, (1+2x1)-450TT
		8	D8	1891		
D9	1	9	D9	1894		458t, 63.0x7.7x3.7m, 3b,1vte, 4200hp, 23.5kts, 52p; 3x1-50/37, (1+2x1)-450TT

DD	D10	1	10	D10	1898		371t, 66.1x6.0x2.4m, 3b,2vte, 5783hp, 27.2kts, 47p; 5x1-50/37, (1+2x1)-450TT
	S90	12	11	S90	1899		394t, 63.0x7.0x2.8m, 3b,2vte, 5900hp, 27kts, 57p; 3x1-50/37(11-17,19-22), 1x1-50/37(18), 3x1-450TT(11-17,19-22)
			12	S91	1900		
			13	S92	1900		
			14	S93	1900		
			15	S94	1900		
			16	S95	1900		
			17	S96	1900		
			18	Sleipner	1900		
			19	S98	1900		
			20	S99	1900		
			21	S100	1901		
	22	S101	1901				
	Taku	1	23	Taku	1898		284t, 59.0x6.4x2.6m, 4b,2vte, 5000hp, 27kts, 57p; 2x1-50/37, 2x1-450TT
	S102	6	24	S102	1901		406t, 63.2x7.0x2.7m, 3b,2vte, 5900hp, 28kts, 57p; 3x1-50/37, 3x1-450TT
			25	S103	1901		
			26	S104	1901		
			27	S105	1901		
			28	S106	1901		
	G108	6	29	S107	1902		440t, 65.8x6.7x2.9m, 3b,2vte, 6600hp, 28kts, 57p; 3x1-50/37, 3x1-450TT
			30	G108	1902		
			31	G109	1902		
32			G110	1903			
33			G111	1902			
34			G112	1902			
S114	6	35	G113			415t, 63.2x7.0x2.7m, 3b,2vte, 5900hp, 27kts, 57p; 3x1-50/37, 3x1-450TT	
		36	S114	1902			
		37	S115	1903			
		38	S116	1903			
		39	S117	1903			
		40	S118	1903			
S120	5	41	S119	1903		468t, 64.7x7.0x2.6m, 3b,2vte, 6400hp, 27.5kts, 61p; 3x1-50/37, 3x1-450TT	
		42	S120	1904			
		43	S121	1904			
		44	S122	1904			
			45	S123	1904		

		46	S124	1904		
S125	1	47	S125	1905		454t, 64.7x7.0x3.2m, 3b,3st, 6600hp, 28kts, 61p; 3x1-50/37, 3x1-450TT
S126	6	48	S126	1905		482t, 64.7x7.0x2.8m, 3b,2vte, 6400hp, 28kts, 61p; 3x1-50/37, 3x1-450TT
		49	S127	1905		
		50	S128	1905		
		51	S129	1905		
		52	S130	1905		
		53	S131	1905		
G132	5	54	G132	1906		544t, 65.7x7.0x2.9m, 3b,2vte, 7000hp, 28kts, 69p; 1x1-88/32(57), 2x1-52/51(57), 4x1-50/37(54-56,58), 3x1-450TT
		55	G133	1906		
		56	G134	1907		
		57	G135	1907		
		58	G136	1907		
G137	1	59	G137	1907		693t, 71.5x7.7x3.2m, 4b,3st, 10800hp, 30kts, 81p; 1x1-88/32, 3x1-52/51, 3x1-450TT
S138	12	60	S138	1907		684t, 70.7x7.8x2.8m, 4b,2vte, 11000hp, 30.3kts, 80p; 1x1-88/32, 3x1-52/51, 3x1-450TT
		61	S139	1907		
		62	S140	1907		
		63	S141	1907		
		64	S142	1907		
		65	S143	1907		
		66	S144	1907		
		67	S145	1907		
		68	S146	1907		
		69	S147	1908		
		70	S148	1908		
		71	S149	1908		
V150	11	72	V150	1907		691t, 72.5x7.8x3.0m, 4b,2vte, 10900hp, 30kts, 84p; 2x1-88/32(72-77), 2x1-88/27(78-82), 3x1-450TT
		73	V151	1908		
		74	V152	1908		
		75	V153	1908		
		76	V154	1908		
		77	V155	1908		
		78	V156	1908		
		79	V157	1908		
		80	V158	1908		
		81	V159	1908		



		82	V160	1908		
V161	1	83	V161	1908		687t, 72.5x7.8x3.0m, 4b,2st, 14800hp, 32kts, 84p; 2x1-88/27, 3x1-450TT
V162	3	84	V162	1909		739t, 73.9x7.9x3.1m, 4b,2st(84,86)-4b,2gt(85), 15100hp, 32kts, 84p; 2x1-88/27, 3x1-450TT
		85	V163	1909		
		86	V164	1909		
G169	2	87	G169	1909		777t, 74.0x7.9x2.8m, 4b,3st, 15000hp, 32kts, 84p; 2x1-88/27, 3x1-450TT
		88	G170	1909		
Nr. XVIII	6	1-6	V1, 2, 5, 7-9	1884		61t, 32.8x3.8x1.8m, 1b,1vte, 590hp, 17.9kts, 14p; 2x5-37/20, 2-350TT
S7	9	7-15	S8, 11, 13-16, 20-22	1885		98t, 37.7x4.9x2.2m, 1b,1vte, 725hp, 20.4kts, 16p; 1x1-50/37, (1+2x1)-350TT
S24	7	16	S24	1886		103t, 37.7x4.8x2.3m, 1b,1vte, 840hp, 19.1kts, 16p; 1x1-50/37, (1+2x1)-350TT
		17	S25	1886		
		18	S27	1886		
		19	S28	1886		
		20	S29	1886		
		21	S30	1887		
		22	S31	1887		
S32	1	23	S32	1886		119t, 39.1x5.3x2.5m, 1b,1vte, 900hp, 19.9kts, 20p; 1x1-50/37, (1+2x1)-350TT
S33	8	24	S33	1887		113t, 39.9x4.8x2.3m, 1b,1vte, 1100hp, 20kts, 16p; 1x1-50/37, (1+2x1)-350TT
		25	S34	1887		
		26	S35	1887		
		27	S36	1887		
		28	S37	1887		
		29	S38	1887		
		30	S39	1887		
		31	S40	1887		
S42	1	32	S42	1889		153t, 44.2x5.0x2.6m, 1b,1vte, 1420hp, 22.2kts, 16p; 1x1-50/37, (1+2x1)-350TT
		33	S43	1889		
		34	S44	1889		
		35	S45	1889		
		36	S46	1889		
		37	S47	1889		

TB

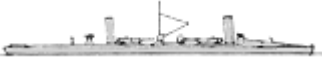
S43	14	38	S49	1890		152t, 44.2x5.0x2.7m, 1b,1vte, 1571hp, 21.5kts, 16p; 1x1-50/37, (1+2x1)-350TT
		39	S50	1890		
		40	S51	1890		
		41	S52	1890		
		42	S53	1890		
		43	S54	1890		
		44	S55	1890		
		45	S56	1890		
		46	S57	1890		
		S58	8	47		
48	S59			1892		
49	S60			1892		
50	S61			1892		
51	S62			1892		
52	S63			1892		
53	S64			1892		
54	S65			1892		
S66	1	55	S66	1893		172t, 47.9x5.4x2.7m, 2b,1vte, 1610hp, 22.1kts, 24p; 1x1-50/37, (1+2x1)-450TT
S67	7	56	S67	1893		166t, 47.9x5.4x2.6m, 1b,1vte, 1600hp, 21.9kts, 24p; 1x1-50/37, (1+2x1)-450TT
		57	S68	1893		
		58	S69	1893		
		59	S70	1893		
		60	S71	1893		
		61	S72	1893		
		62	S73	1894		
S74	1	63	S74	1895		186t, 49.9x5.5x2.8m, 2b,1vte, 2500hp, 23.7kts, 24p; 1x1-50/37, (1+2x1)-450TT
S75	7	64	S75	1895		180t, 49.0x5.3x2.9m, 2b,1vte, 1744hp, 22.3kts, 24p; 1x1-50/37, (1+2x1)-450TT
		65	S76	1895		
		66	S77	1895		
		67	S78	1895		
		68	S79	1895		
		69	S80	1895		
		70	S81	1896		
S82	6	71	S82	1897		170t, 48.2x5.1x2.6m, 2b,1vte, 2146hp, 25.3kts, 29p; 1x1-50/37, (1+2x1)-450TT
		72	S83	1897		
		73	S84	1897		
		74	S85	1898		
		75	S86	1898		

			76	S87	1898		
G88	2		77	G88	1898		177t, 48.7x5.0x2.8m, 2b,1vqe, 2468hp, 26kts, 29p; 1x1-50/37, (1+2x1)-450TT
			78	G89	1898		

SUBMARINES



SS	U1	1	1	U1	1906		238/283t, 42.4x3.8x3.2m, 2pe/em, 400/400hp, 10.8/8.7kts, 12p, 30m; 1-450TT
	U2	1	2	U2	1908		341/430t, 45.4x5.5x3.1m, 2pe/em, 600/630hp, 13.2/9kts, 22p, 30m; 4-450TT
	U3	2	3	U3	1909		421/510t, 51.3x5.6x3.1m, 2pe/em, 600/1030hp, 11.8/9.4kts, 22p, 30m; 4-450TT
4			U4	1909			

ESCORTS

PC	Sirius	4	1-4	Sirius, Vega, Castor, Pollux	1889-1890		52t, 22.6x4.6x1.6m, 1b,1vte, 200hp,; mines(4)
----	--------	---	-----	------------------------------	-----------	---	---

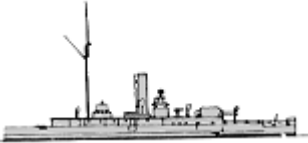
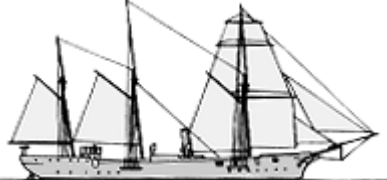
OTHER FIGHTING SHIPS

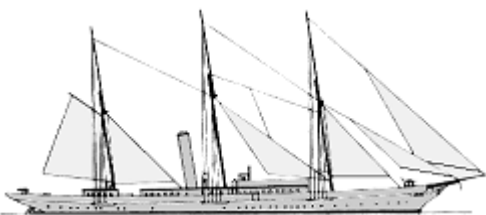
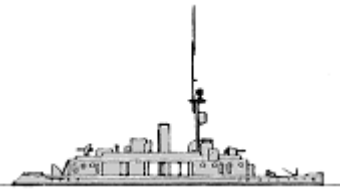
PG	Wespe	7	1	Biene	1877		1163t, 46.4x10.6x3.4m, 4b,2dc, 700hp, 10kts, 88p; iron- 203belt, 40deck, 203barbette, 20CT; 1x1-305/20, 2x1-87/22, 2x5-37/20, 2-350TT
			2	Mücke	1878		
			3	Scorpion	1877		
			4	Basilisk	1880		
			5	Crocodill	1880		
			6	Natter	1881		
			7	Hummel	1881		
PG	Wolf	1	8	Hyäne	1879		570t, 47.2x7.7x3.4m, 2b,1hse, 340hp, 8.5kts, 106p; 2x1-125/21, 2x1-87/22, 3x5-37/20
			Iltis	6	9	Iltis	1898
10	Jaguar	1899					
11	Tiger	1900					
12	Luchs	1900					
13	Panther	1902					
14	Eber	1903					
APG	-	1	1	Lorelei	1886		924t

							
PGR	Tsingtau	2	1	Tsingtau	1904		280t, 50.1x8.0x0.9m, 2b,2vte, 1300hp, 13kts, 47p; 1x1-88/27, 1x1-50/37
		2		Vaterland	1904		
APGR	-	1	1	Vorwärts	1899		406t

AMPHIBIOUS SHIPS

LC	Pferdeboot	14	1-14	P.B.9 L.N.1-14	1904-1909		14t, 10.5x3.4x0.6m, 1pe, 30hp, 13.5kts, 2p; 10t of cargo
----	------------	----	------	----------------	-----------	---	--

MINE WARFARE SHIPS

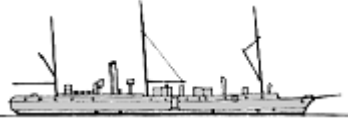
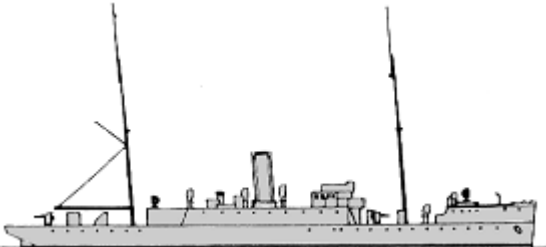
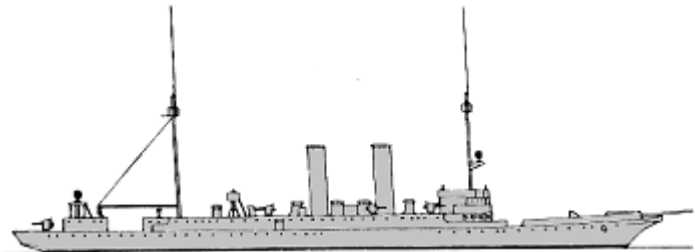
ML	Rhein	1	1	Rhein	1867		482t, 47.1x6.0x3.2m, 1b,1vse, 200hp, 9kts, 81p; 2x5-37/20, 100mines
	Pelikan	1	2	Pelikan	1891		2424t, 84.2x11.7x5.1m, 2b,2vte, 3000hp, 15kts, 195p; 4x1-88/27, 400mines
	Nautilus	1	3	Nautilus	1907		2345t, 98.2x11.2x4.5m, 4b,2vte, 6600hp, 20kts, 201p; 8x1-88/32, 391mines
	Albatross	1	4	Albatross	1908		2506t, 100.9x11.5x4.6m, 4b,2vte, 6600hp, 20kts, 208p; 8x1-88/32, 288mines

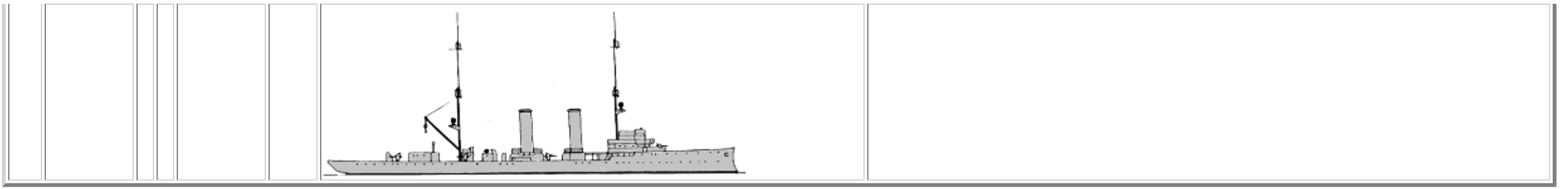

Google
Custom Search

© Ivan Gogin, 2014

[home](#)[World navies yesterday](#)[1910](#)

Greece 01 January 1910

BATTLESHIPS

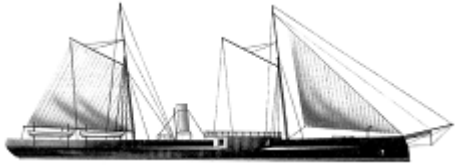
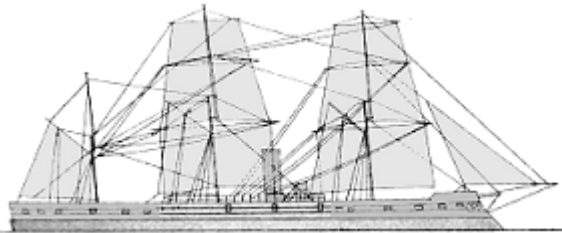
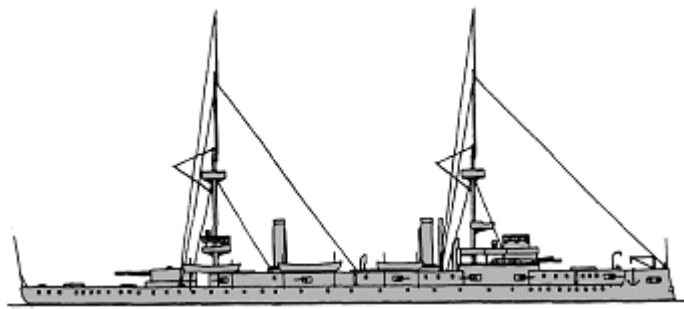

BC	Vasilefs Georgios	1	1	Vasilefs Georgios	1868		1774t, 61.0ppx10.1x4.9m, 4b,2vte, 3000hp, 14kts, 152p; iron- 178belt, 152battery, 25deck; 2x1-209/20, 1x1-149/27, 9x1-37/37
	Vasilissa Olga	1	2	Vasilissa Olga	1870		2030t, 76.0ppx11.9x5.8m, 4b,1vte, 4000hp, 16.5kts, 258p; iron- 152belt, 121battery, 25deck; 4x1-173/22, 2x1-173/17, 4x1-75/35, 4x5-37/17
	Idra	3	Idra	1892		1891	4885t, 102.0ppx15.8x5.5m, 4b,2vte, 6700hp, 17kts, 440p; steel, compound- 305belt, 57deck, 350casemate, 305barbette; 2x1-274/34, 1x1-274/28, 1x1-100/48, 8x1-65/50, 4x1-47/40, 10x5-37/17, 1-381TT, 2-356TT
4		Spetsai	1892				
5		Psara	1891				

CRUISERS

CLL	Navarchos Miaoulis	1	1	Navarchos Miaoulis	1879	No picture	1820t, 75.0ppx11.0x4.4m, 1hc, 2400hp, 13.5kts, 180p; 3x1-173/22, 1x1-173/17, 6x1-37/20, 3-356TT
-----	--------------------	---	---	--------------------	------	------------	---

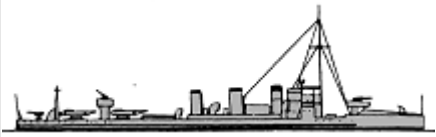
TORPEDO SHIPS

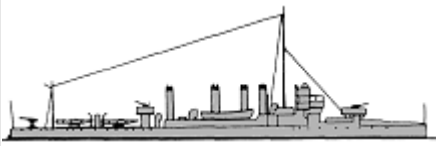
DD	Niki	4	1	Niki	1906		350t, 67.0x6.6x2.7m, 4b,2vte, 6800hp, 30kts, 58p; 2x1-76/51, 4x1-57/59, 2x1-450TT
			2	Doxa	1906		
			3	Aspis	1907		
			4	Velos	1907		
			5	Thyella	1907		

	Thyella	4	6	Nafkratoussa	1906		380t, 67.1x6.2x1.8m, 4b,2vte, 30kts, 70p; 2x1-76/51, 4x1-57/59, 2x1-450TT
			7	Lonchi	1907		
			8	Sfendoni	1907		
TB	Ionia	1	1	No.18	1881	No picture	35t, 27.1x3.4x1.0m, 1b,1vc, 500hp, 17.5kts, 9p; 2-356TC
	Samos	6	2-7	No.6-10, 17	1881	No picture	40t, 30.5x3.7x1.3m, 1b,1vc, 450hp, 19.5kts, 12p; 2x5-37/17, 2-356TT
	No11	5	8-12	No.11, 12, 14-16	1885		85t, 37.5x4.7x1.7m, 1b,1vc, 1000hp, 18kts, 20p; 1x5-37/17, (2+1x1)-356TT

OTHER FIGHTING SHIPS

PG	Afroessa	1	1	Plixavra	1857	No picture	380t, 38.0x7.0x2.7m, 160hp, 9kts; 1x1-87/22
	Sfaktiria	4	2-5	Alfa, Beta, Gamma, Delta	1880-1881	No picture	52t, 22.0x4.5x1.5m; 1x1-149/24, 1spar torpedo
	Hydra	2	6	Amvrakia	1881	No picture	470t, 39.0ppx7.9x2.2m, 2vc, 690hp, 12kts, 64p; 1x1-263/27, 1x1-149/27, 2x1-37/20, 1-356TT
			7	Aktion	1881		
	Achelaos	4	8	Achelaos	1884		400-420t, 41.0-42.0x7.4-7.6x3.5-4.0m, vc, 400hp, 9.8(8,9)-10.5(10,11)kts, 73p; 2x1-95/26, 2x1-37/20(8,9), 3x1-37/20(10,11)
			9	Alpheos	1884		
			10	Eurotas	1884		
			11	Peneos	1885		
Aidon	1	12	Aidon	1884	No picture	86t	
Kichli	2	13, 14	Kichli, Kissa	1884	No picture	86t, 24.2x4.9x2.1m, 1vc, 162hp, 10kts	

MINE WARFARE SHIPS

ML	Aigialeia	3	1	Aigialeia	1881	No picture	300t, 23.0x4.0x2.6m, 1vc, 300hp, 9kts; 20mines
			2	Monemvasia	1881		
			3	Nafplia	1881		
AML	-	1	1	Kanaris	1878		870t, 91.2x9.2m, 500hp, 14kts; 2x1-120/22, 2x5-37/17, 4-356TT, mines

© Ivan Gogin, 2014



[home](#)[World navies yesterday](#)[1910](#)

Haiti 01 January 1910

CRUISERS

CL	Dessalines	1	1	Dessalines	1883	No picture	1200t, 56.4x9.8x4.5m, 760hp, 16kts; 2x1-107/29, 1x1-100/26, 2x1-87/22
----	------------	---	---	------------	------	------------	---

OTHER FIGHTING SHIPS

PG	22 Décembre 1804	1	1	22 Décembre 1804	1860	No picture	900t, 63.4x9.1x4.9m, 360hp, 9kts; 4x1-121/22
	1804	1	2	1804	1875	No picture	600t, 44.2x8.8x3.1m, 100hp, 12kts; 6x1-121/22
	Saint Michael	1	3	Saint Michael	1875	No picture	850t, 49.4x10.7x3.4m, 120hp, 12kts; 1x1-279/12, 8x1-102/22
	Toussaint Louverture	1	4	Toussaint Louverture	1886		500t, 50.0ppx7.5x3.3m, 1vc, 790hp, 13kts; 1x1-165/28, 2x1-120/27
	Capois La Mort	2	5	Capois La Mort	1893		256t, 45.0x6.2x2.1m, 680hp, 14kts; 1x1-100/50, 4x1-37/20
			6	Alexander Pétion	1893		

© Ivan Gogin, 2015

[home](#)[World navies yesterday](#)[1910](#)

Honduras 01 January 1910

OTHER FIGHTING SHIPS

PG	Tatumbla	1	1	Tatumbla	1900s	No picture	200t, 12kts, 44p; 2x1-small guns
----	----------	---	---	----------	-------	------------	----------------------------------

COASTAL FORCES

YP	22 Februar	1	1	22 Februar	1897	No picture	13t, 22hp
	Liberia	1	2	Liberia	1908	No picture	24t, 25.9x3.7x1.4m, 1pe, 120hp, 13kts; 1x1-37/27

© Ivan Gogin, 2015

[home](#)[World navies yesterday](#)[1910](#)

Italy 01 January 1910

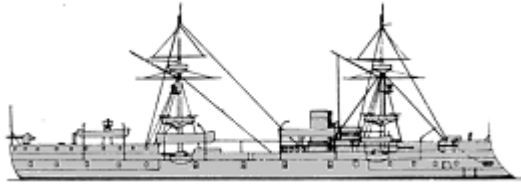
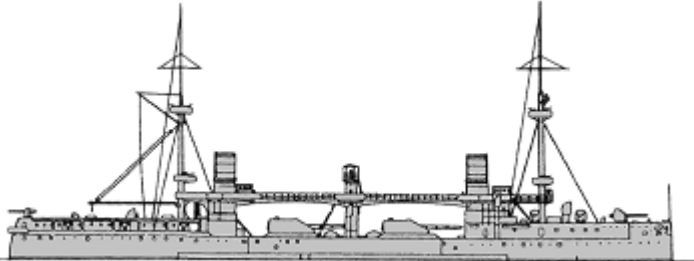
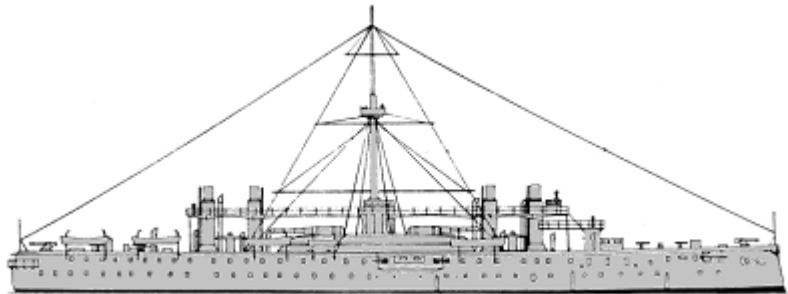
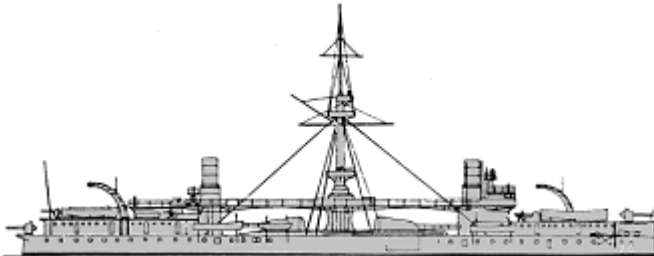

BATTLESHIPS

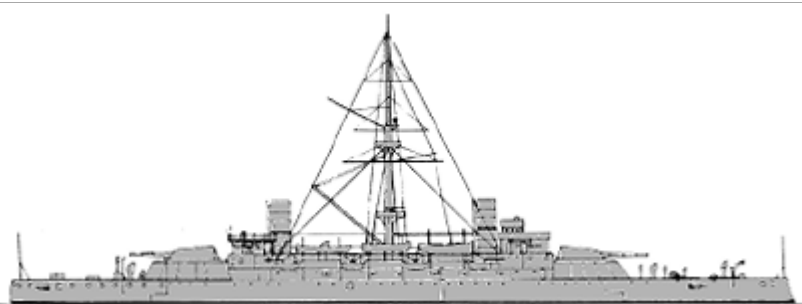
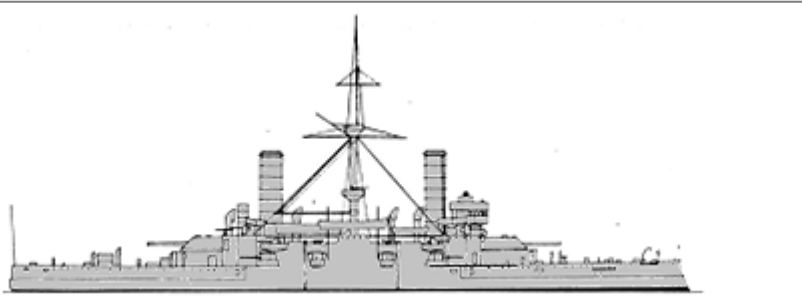
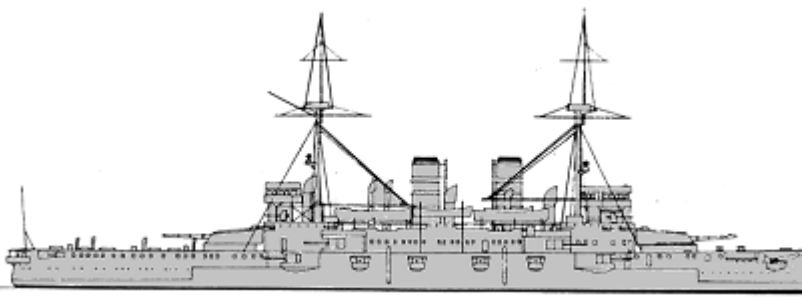
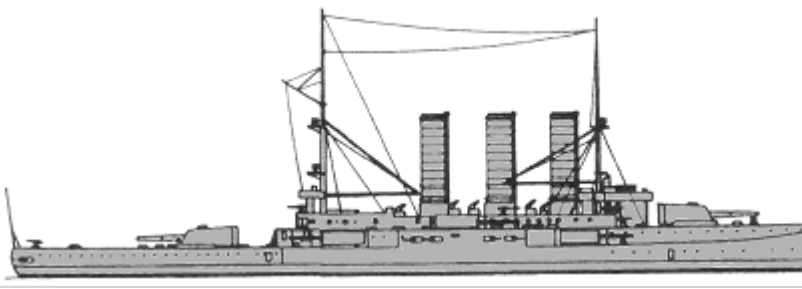
	Regina Maria Pia	1	1	Castelfidardo	1864		4527t, 81.8x15.2x6.4m, 8b,1hse, 2125hp, 12.1kts, 484p; iron, 110belt, 110battery; 1x1-76/40, 1x1-75/21, 4x1-57/43, 1x1-47/40, 2x5-37/20, 2-450TT
	Duilio	1	2	Dandolo	1882		11264t, 109.2x19.7x8.3m, 8b,2vc, 8045hp, 15.6kts, 495p; steel, 550belt, 50deck, 225turrets; 2x2-254/40, 7x1-152/40, 5x1-120/40, 16x1-57/43, 8x5-37/20, 4x1-11.4/94, 4-450TT
	Italia	2	3	Italia	1885		15047(3)-15649(4)t, 124.7x22.5(3)-22.3(4)x8.8(3)-9.4(4)m, 24b,4vc, 11986(3)-15797(4)hp, 17.8(3)-18.4(4)kts, 669p; 2x2-432/26-27(3), 2x2-432/27(4), 8x1-152/32(4), 6x1-149/26(3), 4x1-120/32, 2x1-76/40, 12x1-57/40(4), 2x5-37/20(3), 12x5-37/20(4), 2x1-11.4/94(3), 6-350TT(3), 4-350TT(4); 10000men
			4	Lepanto	1887		
	Ruggiero di Lauria	1	5	Andrea Doria	1891		11027t, 105.9x19.8x8.3m, 8b,2vc, 10000-10500hp, 16-17kts, 507p; steel, 450belt, 75deck, 360barbettes, 250CT; 2x2-432/27, 2x1-153/32, 4x1-120/32, 2-350TT
BB	Re Umberto	3	6	Re Umberto	1893		15454(6)-14842(7)-15426(8)t, 127.6(6)-130.7(7,8)x23.4x9.3(6)-8.8(7,8)m, 18b,2vc(6,7)-18b,2vte(8), 17000(6)-19131(7)-22800(8)hp, 18.2(6)-20(7,8)kts, 733-794p; steel, 100belt, 75deck, 100turrets, 300CT; 2x2-343/30, 8x1-152/40, 16x1-
			7	Sicilia	1895		

		8	Sardegna	1895		57/43(6), 20x1-57/43(7,8), 10x1-37/25, 5-450TT
Ammiraglio di Saint Bon	2	9	Ammiraglio di Saint Bon	1901		9940-10531t, 111.8x21.1x7.7m, 12b,2vte, 14000hp, 18.2kts, 565p; Harvey, 250belt, 70deck, 250turrets, 250CT; 2x2-254/40, 8x1-152/40, 8x1-120/40, 6x1-76/40(10), 8x1-57/43(9), 8x1-47/40(10), 2x1-37/25(9), 4-450TT
		10	Emanuele Filiberto	1902		
Regina Margherita	2	11	Regina Margherita	1904		14093(11)-14737(12)t, 138.7x23.8x8.8(11)-9.0(12)m, 28b,2vte, 20475-21790hp, 20kts, 900p; Harvey, 150belt, 80deck, 200turrets, 150CT; 2x2-305/40, 4x1-203/45, 12x1-152/40, 20x1-76/40, 2x1-47/40, 2x1-37/25, 2x1-11.4/94, 4-450TT
		12	Benedetto Brin	1905		
Regina Elena	4	13	Regina Elena	1907		13864-14192t, 144.6x22.4x8.5m, 28b,2vte(13,14)-18b,2vte(15)-22b,2vte(16), 19299-21968hp, 21kts, 764p; Harvey, 250belt, 38deck, 250turrets, 250CT; 2x1-305/40, 6x2-203/45, 16x1-76/40(13,14), 24x1-76/40(15,16), 2x1-47, 2-450TT
		14	Vittorio Emanuele	1908		
		15	Roma	1908		
		16	Napoli	1908		

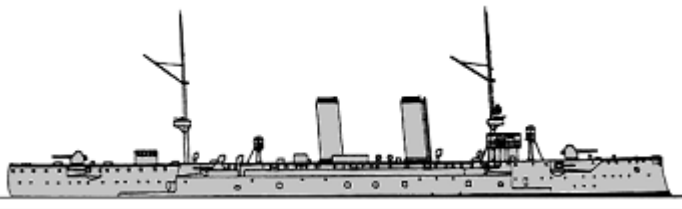
CRUISERS

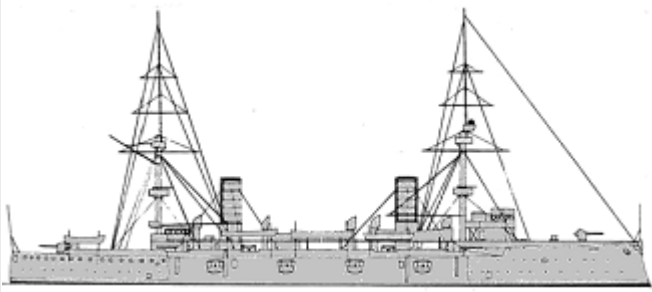
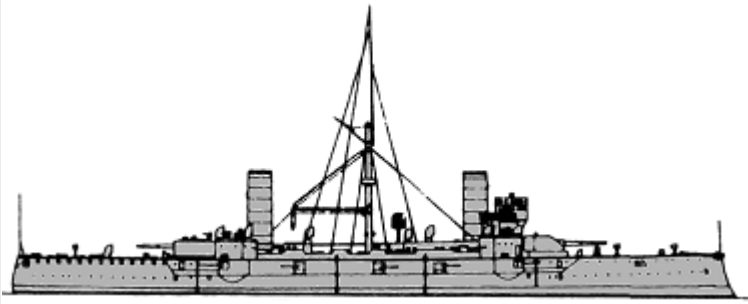
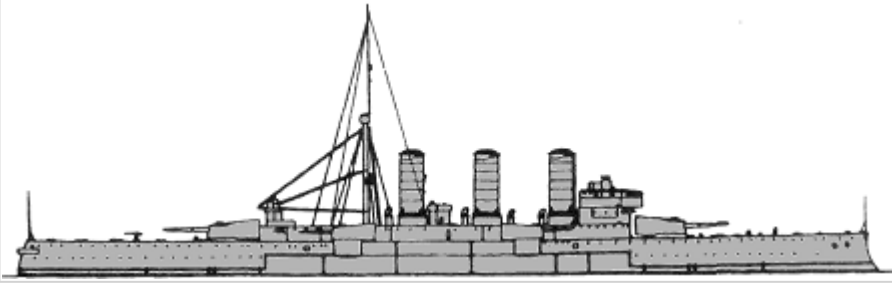
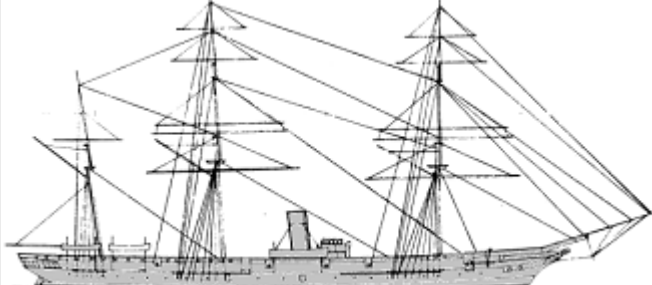

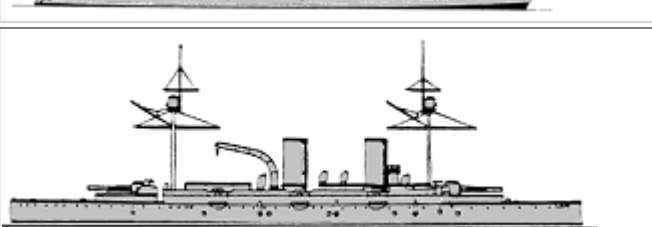

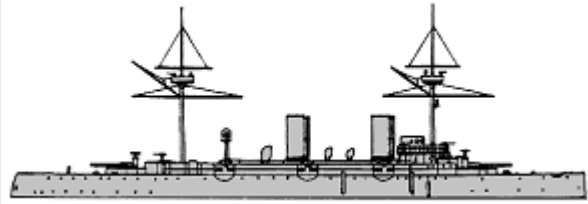
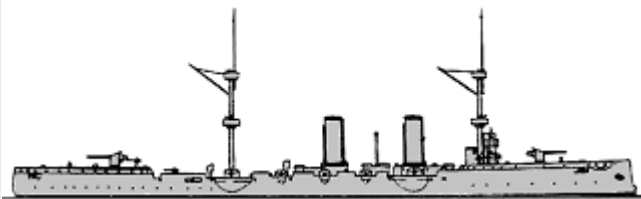
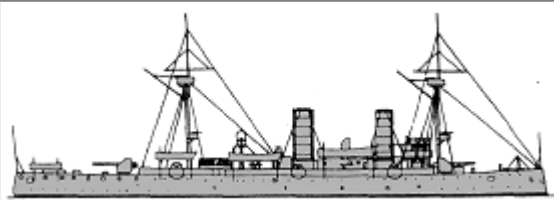
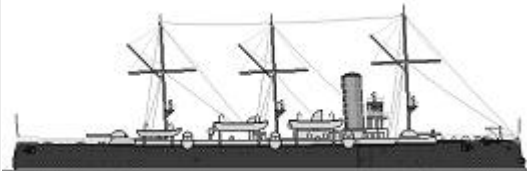
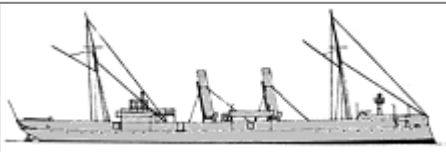
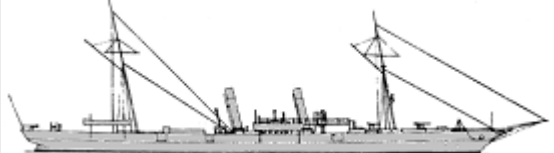



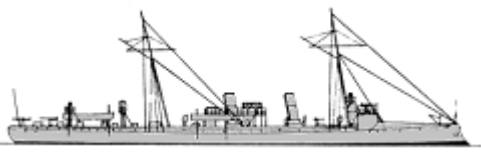

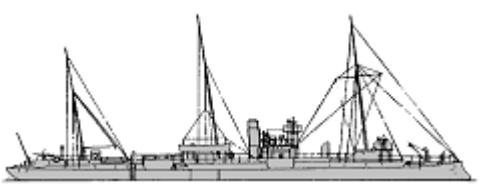
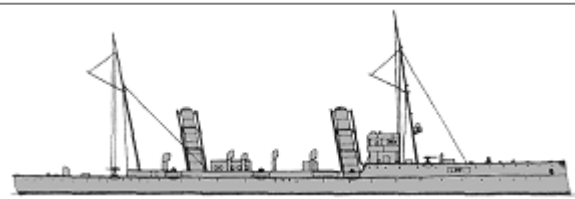

Marco Polo	1	1	Marco Polo	1894		4820t, 106.1x14.7x5.9m, 4b,2vte, 10663t, 17.8kts, 402p; 100belt, 25deck, 50shields, 50CT; 6x1-152/40, 10x1-120/40, 2x1-75/21, 9x1-57/40, 2x1-37/25, 2x1-11.4/94, 5-450TT
Vettor Pisani	2	2	Carlo Alberto	1898		7057(2)-7128(3)t, 105.7x18.0x7.2m, 8b,2vte, 13219(2)-13259(3)hp, 19.1(2)-18.6(3)kts, 486p; Harvey, 150belt, 37deck, 150casemates, 150CT; 12x1-152/40, 6x1-120/40(2), 4x1-120/40(3), 2x1-75/21, 14x1-57/40, 6x1-37/25(2), 8x1-37/25(3), 2x1-11.4/94, 4-450TT
			Vettor			

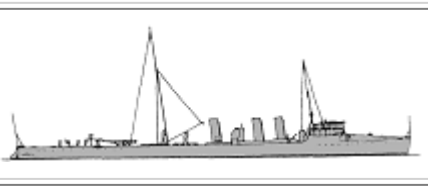





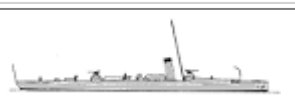

CA		3	Pisani	1899		
	Garibaldi	4	Varese	1901		7972t, 111.8x18.3x7.1m, 24b,2vte, 13500hp, 19.5kts, 559p; 150belt, 38deck, 150turrets, 150CT; 1x1-254/40, 1x2-203/45, 14x1-152/40, 10x1-76/40, 6x1-47/40, 4-450TT
		5	Giuseppe Garibaldi	1901		
		6	Francesco Ferruccio	1905		
	Amalfi	7	Pisa	1909		10600(7)-10401(8)t, 140.5x21.0x7.1m, 22b,2vte, 20000hp, 23kts, 687p; 200belt, 130deck, 160turrets, 180CT; 2x2-254/45, 4x2-190/45, 16x1-76/50, 8x1-47/50, 3-450TT
		8	Amalfi	1909		
	Flavio Gioia	1	1	Flavio Gioia	1883	
Amerigo Vespucci		2	Amerigo Vespucci	1884		2751t, 84.5x12.8x5.5m, 8b,1hr, 3000hp, 13kts, 268p; 4x1-120/40, 4x1-57/40, 2x1-37/20, 2-350TT
		3	Giovanni Bausan	1885		3277t, 89.3x12.9x6.0m, 4b,2vde, 6470hp, 17.4kts, 295p; compound, 38deck, 13CT; 2x1-254/30, 6x1-152/40, 4x1-57/40, (6x5+3x1)-37/20, 2x1-11.4/94, 2-350TT

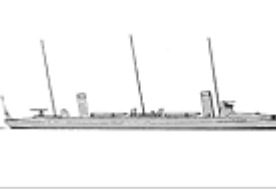
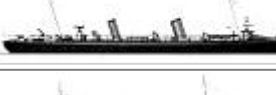
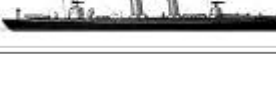
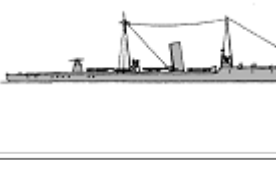

CL	Etna	4	Etna	1887		3737-3888t, 91.4x13.2x5.8m, 4b,2vde, 6252-7480hp, 16.6-18kts, 308p; compound, 38deck, 13CT; 4x1-152/40(4), 8x1-152/40(5), 2x1-120/40(4), 2x1-76/40(4), 1x1-75/21, 4x1-57/40(4), 5x1-57/40(5), 2x1-47/40(4), 2x1-37/25(4), (1x5+6x1)-37/20(5), 1x1-11.4/94(4), 3x1-11.4/94(5), 2-350TT	
		5	Vesuvio	1888			
	Piemonte	1	6	Piemonte	1889		2597t, 97.8x11.6x4.9m, 4b,2vte, 7100hp, 20.4kts, 298p; compound, 76deck, 114shields, 76CT; 2x1-152/40, 10x1-120/40, 10x1-57/40, 6x1-37/20, 4x1-11.4/94, 2-350TT
	Umbria	5	6	Lombardia	1893		2411-2750(7-9,11)-2950(10)t, 84.8(6-8)-88.2(9)-88.3(10)x12.0(6-8)-12.7(9)-12.0(11)x4.7-5.5m, 4b,2hte(6-9)-4b,2vte(10), 6842-7677hp, 17-19.8kts, 213-278p; Harvey, 50(6-9)-25(10)deck, 50CT; 2x1-152/40(6-9), 8x1-120/40(6-9), 6x1-120/40(10), 8x1-57/40(6-9), 6x1-57/40(10), 8x1-37/25(6-9), 2-450TT(6-9)
			7	Etruria	1894		
8			Liguria	1894			
9			Elba	1896			
	10	Puglia	1901				
Calabria	1	11	Calabria	1897		2660t, 81.0x12.7x5.1m, 4b,2vte, 4260hp, 16.4kts, 254p; 50deck, 50CT; 4x1-152/40, 6x1-120/40, 8x1-57/40, 8x1-37/25, 2-450TT	
SL	Agostino Barbarigo	1	Agostino Barbarigo	1879		805(1)-770(2)t, 68.1x7.4x3.4m, 4b,1vte, 1704-1760hp, 15kts, 104p; 5x1-57/43, 2x1-25/41	
		2	Marcantonio Colonna	1880			
	Archimede	1	3	Galileo Galilei	1888		886t, 77.0x8.0x3.8m, 4b,1vte, 1384-1411hp, 12kts, 73p; 4x1-57/43, 1x1-11.4/94

TORPEDO SHIPS



PGT	Tripoli	1	1	Tripoli	1886		952t, 73.4x7.9x3.7m, 6b,3de, 2500hp, 17.5kts, 111p; steel, 40deck; 1x1-76/40, 6x1-57/40, 1x1-47/40, 3-350TT	
		Goito	2	2	Goito	1888		955-974t, 73.4x7.9-8.0x3.0-3.6m, 6b,2vde(2)-6b,3vte(3), 2500(2)-3180(3)hp, 18(3)-17(2)kts, 121p; steel, 40deck; 6x1-57/40(3), 5x1-57/40(2), (3x5+2x1)-37/20(2), 2x1-37/20(3), 4-350TT(3), 60mines(2)
	3		3	Montebello	1889			
			4	4	Partenope	1890		821-931t, 73.1x8.2x3.5m, 4b,2vte, 2481(4)-3884-4422(5-9)hp, 17.1(4)-18.1-20.8(5-9)kts, 121p;
			5	5	Minerva	1892		
			6	6	Urania	1893		

DD	Partenope	6					1x1-120/40(5-8), 2x1-120/40(9), 2x1-76/40(4), 6x1-57/43(5-8), 4x1-57/43(4,9), 3x1-37/20(5-8), 2x1-37/20(4,9), (2+4x1)-450TT(5-9), 20mines(4)	
			7	Iride	1892			
			8	Aretusa	1892			
			9	Caprera	1895			
	Agordat	2	10	Agordat	1900		1340-1292t, 91.6x9.3x3.6m, 8b,2vte, 7500(10)-8000(11)hp, 22(10)-22.5(11)kts, 185p; steel, 20deck; 12x1-76/40, 2x1-450TT	
			11	Coatit	1900			
	DD	Fulmine	1	1	Fulmine	1900		337t, 62.2x6.4x2.3m, 4b,2vte, 4729hp, 24kts, 48p; 1x1-76/40, 3x1-57/43, 2x1-350TT
		Lampo	6	2	Lampo	1900		348t, 62.1x6.5x2.6m, 4b,2vte, 5230-5998hp, 30kts, 61p; 1x1-76/40(2-4,6), 5x1-57/43(2-4,6), 6x1-57/43(5,7), 2x1-350TT
				3	Freccia	1902		
				4	Dardo	1901		
5				Strale	1901			
6				Euro	1901			
7				Ostro	1901			
Nembo		6	8	Nembo	1902		380t, 64.0x5.9x2.3m, 3b,2vte, 5200-5350hp, 30kts, 58p; 4x1-76/40, 2x1-450TT	
			9	Turbine	1902			
			10	Aquilone	1903			
			11	Borea	1903			
			12	Zeffiro	1905			
			13	Espero	1905			
Artigliere		4	14	Artigliere	1907		412t, 65.0x6.1x2.1m, 3b,2vte, 6000hp, 28.5kts, 55p; 4x1-76/40, 3x1-450TT, 10mines	
			15	Bersagliere	1907			
			16	Granatiere	1907			
			17	Lanciere	1907			
Aldebaran	3	1-3	26T, 31T, 35T	1882-1883		39t, 30.6x3.6x1.7m, 1b,1vde, 430-455hp, 21kts, 11p; 1x2-25/41, 2-350TT		
Arturo	3	4-6	38T, 46T, 51T	1885-1887		39t, 30.6x3.6x1.7m, 1b,1vde, 430-455hp, 21kts, 11p; 1x2-25/41, 2-350TT		
Vega	2	7, 8	36T, 52T	1885-1887		39t, 30.6x3.6x1.7m, 1b,1vde, 430hp, 21kts, 11p; 1x2-25/41, 2-350TT		
Procione	1	9	48T	1886		39t, 30.6x3.6x1.7m, 1b,1vde, 390-430hp, 21kts, 11p; 1x2-25/41, 2-350TT		
Acquario	1	10	43T	1885		39t, 30.6x3.6x1.7m, 1b,1vde, 387-430hp, 21kts, 11p; 1x2-25/41, 2-350TT		
56S	12	11-22	99S-104S, 106S-111S	1887		78t, 39.8x4.8x2.0m, 1b,1vde, 902-1080hp, 21-22kts, 17p; 2x1-37/20, (1+1x1)-350TT		
76Ya	1	23	76Ya	1887		108t, 41.2x4.3x1.5m, 2b,2vde, 1600hp, 26kts, 20p; 2x5-37/20, (2+1x2)-350TT		
			105S, 112S-123S, 128S-	1887				





TB	72S	24	24-47	131S, 136S-138S, 147S-150S	- 1895		78t, 39.8x4.8x2.0m, 1b,1vde, 902-1080hp, 21-22kts, 17p; 2x1-37/25, (1+1x1)-350TT
	68S	7	48-54	116S-119S, 146S, 153S, 154S	1887 - 1894		78t, 39.8x4.8x2.0m, 1b,1vde, 723-1946hp, 21-22kts, 17p; 2x1-37/25, (1+1x1)-350TT
	60S	10	55-64	112S-115S, 132S-135S, 151S, 152S	1888 - 1894		78t, 39.8x4.8x2.0m, 1b,1vde, 683-1082hp, 21-22kts, 17p; 2x1-37/25, (1+1x1)-350TT
	56S	18	65-82	80S, 86S-92S, 124S-127S, 139S-144S	1888 - 1893		78t, 39.8x4.8x2.0m, 1b,1vde, 782-1079hp, 21-22kts, 17p; 2x1-37/25, (1+1x1)-350TT
	Aquila	5	83	Aquila	1888		137t, 47.6x5.1x2.2m, 2b,2vde, 2180hp, 24kts, 24p; 2x1-37/25, (1+2x1)-350TT
			84	Sparviero	1888		
			85	Falco	1888		
			86	Nibbio	1888		
			87	Avvoltoio	1888		
	Condore	1	88	Condore	1900		138t, 48.0x5.6x1.4m, 2b,2vte, 2370hp, 26kts, 31p; 2x1-37/25, 2x1-350TT
	Pellicano	1	89	Pellicano	1900		181t, 48.7x5.7x1.5m, 3b,2vte, 2740hp, 21kts, 30p; 2x1-37/25, 2x1-350TT
	Sirio	5	90	Sirio	1905		207t, 51.1x6.0x1.6m, 2b,2vte, 3100hp, 25.5kts, 38p; 3x1-47/40, 3x1-450TT
			91	Sagittario	1905		
			92	Spica	1905		
			93	Scorpione	1905		
			94	Saffo	1906		
	Pegaso	4	95	Perseo	1906		207t, 50.4x5.3x1.7m, 2b,2vte, 2900-3279hp, 25-26.6kts, 42p; 2x1-57/43, 1x1-47/40, 3x1-450TT
96			Pegaso	1905			
97			Procione	1906			
98			Pallade	1906			
Cigno	8	99	Calipso	1909		208(99,105)-217(99-104,106)t, 50.3x5.3x1.7m, 2b,2vte, 2900hp, 25kts, 38p; 3x1-47/40, 3x1-450TT	
		100	Calliope	1906			
		101	Canopo	1907			
		102	Cassiopea	1906			
		103	Centauro	1907			
		104	Cigno	1906			
		105	Climene	1909			
		106	Clio	1907			
Alcione	6	107	Airone	1907		217t, 50.3x5.3x1.7m, 2b,2vte, 2900hp, 25kts, 38p; 3x1-47/40, 3x1-450TT	
		108	Albatros	1907			
		109	Alcione	1907			
		110	Ardea	1907			
		111	Arpia	1908			

			112	Astore	1908		
Orione	4		113	Olimpia	1907		220t, 52.6x6.0x1.5m, 2b,2vte, 2900hp, 25kts, 38p; 3x1-47/40, 3x1-450TT
			114	Orfeo	1907		
			115	Orione	1907		
			116	Orsa	1907		
Gabbiano	1	117	Gabbiano	1907		174t, 49.6x5.9x1.7m, 2b,2vc, 2200hp, 22kts, 32p; 2x1-47/40, 3x1-350TT, 14mines	

SUBMARINES

SS	Delfino	1	1	Delfino	1895		102/113t, 24.7x2.9x2.8m, 1pe/em, 130/65hp, 10/5kts, 11p, 30m; 1-450TT
	Glauco	5	2	Glauco	1905		157-161/240-244t, 36.8x4.3x2.6m, 2pe/em, 600/170hp, 13/6kts, 15p, 25m; 3-450TT(2), 2-450TT(3-6)
			3	Narvalo	1907		
			4	Otaria	1908		
			5	Squalo	1906		
			6	Tricheco	1909		
	Foca	1	7	Foca	1909		185/280t, 42.5x4.2x2.6m, 3pe/2em, 800/160hp, 16/6kts, 17p, 35m; 2-450TT

OTHER FIGHTING SHIPS

PG	Curtatone	2	1	Volturno	1889		1155(1)-1039(2)t, 54.1ppx9.9x4.5m, 3b,1vc, 1110(1)-1043(2)hp, 11.4(1)-10.7(2)kts, 144p; 4x1-120/32, 4x1-57/43, 1-350TT
			2	Curtatone	1890		
	Castore	1	3	Polluce	1891		522t, 35.1x11.3x2.5m, 2b,1vc, 364hp, 8kts, 49p; 1x1-120/40, 1x1-11.4/94
	Governolo	1	4	Governolo	1896		1203t, 56.4ppx10.3x4.6m, 3b,1vc, 1100hp, 14kts, 137p; 4x1-120/32, 4x1-57/43, 2x1-37/25, 2x1-11.4/94, 1-450TT
Brondolo	2	5	Brondolo	1909			117t, 38.1x6.3x0.8m, 1b,2vte, 500hp, 13kts, 18p; 1x1-76/40, mines
		6	Marghera	1909			

MINE WARFARE SHIPS

ML	Castore	1	1	Castore	1889		522t, 35.1x11.3x2.5m, 2b,1vc, 364hp, 8kts, 49p; 20mines
----	---------	---	---	---------	------	--	---

						
AML	-	1	1	Betta N.3	1891	580t; mines





© Ivan Gogin, 2014

[home](#)[World navies yesterday](#)[1910](#)

Japan 01 January 1910

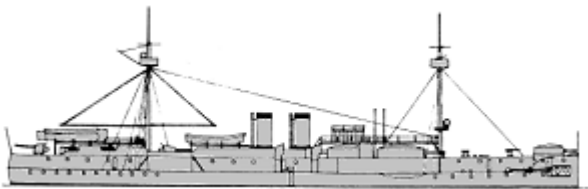
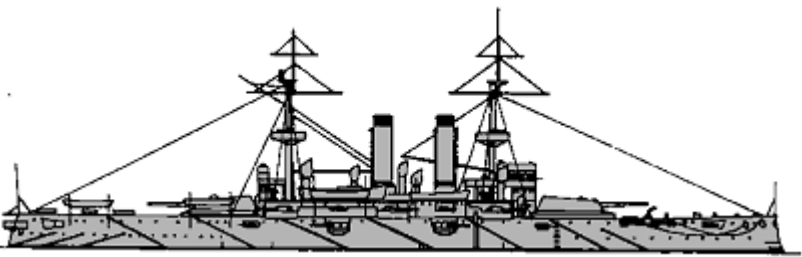
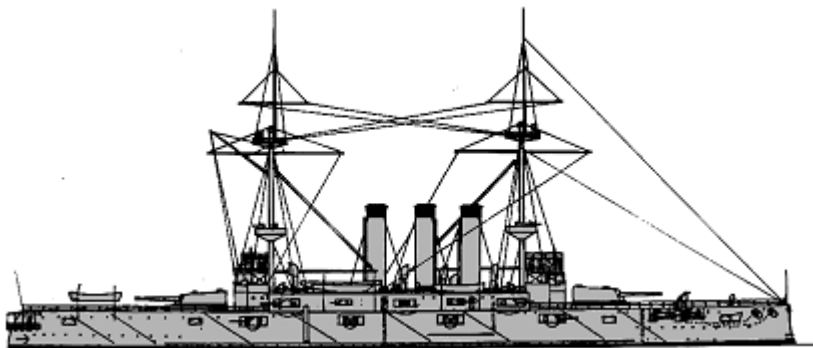
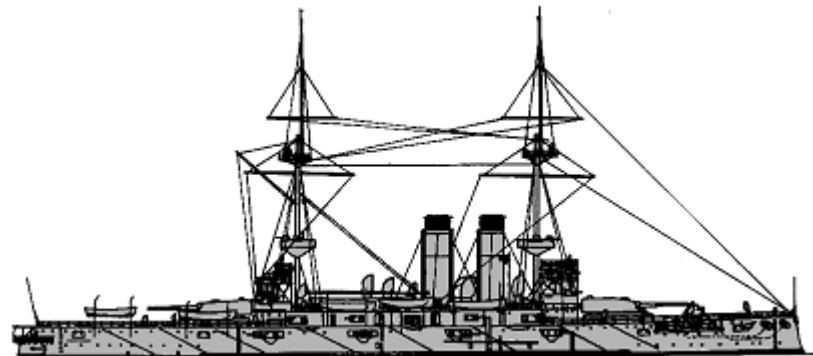
BATTLESHIPS

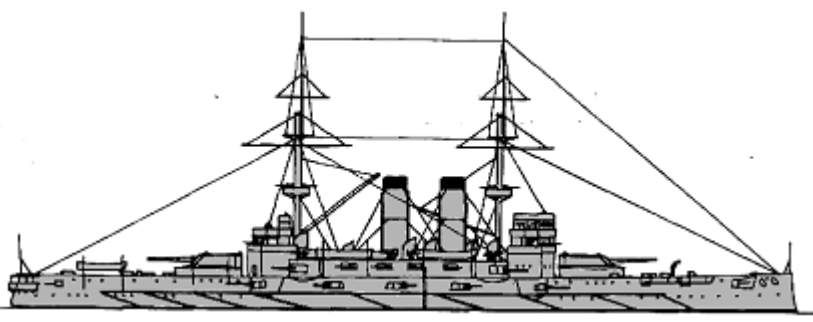
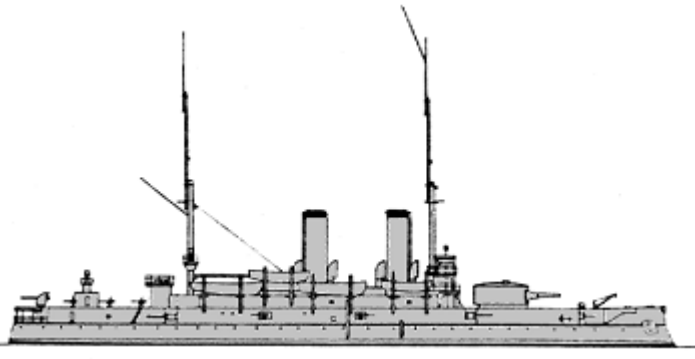
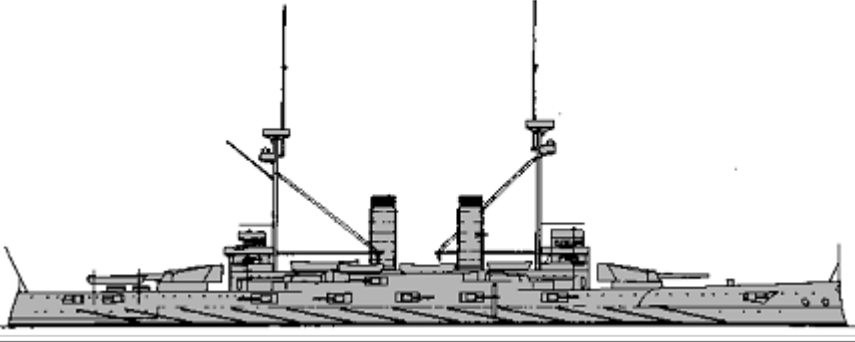
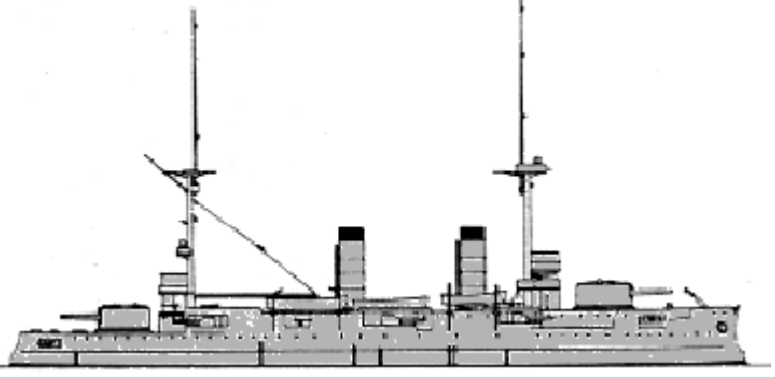

Chin Yen	1	1	Chin Yen	1885		7670t, 93.9x18.0x6.1m, 8b,2hc, 6300hp, 14.5kts, 329p; steel-356belt, 76deck, 305turrets, 203CT; 2x2-305/22, 4x1-152/40, 2x1-57/43, 8x1-47/40, 3-350TT, 2tb
Fuji	1	2	Fuji	1897		12533t, 125.5x22.2x8.1m, 10b,2vte, 14000hp, 18kts, 741p; Harvey- 457belt, 63deck, 152turrets, 356CT; 2x2-305/40, 10x1-152/40, 16x1-76/40, 4x1-47/40, 4x1-47/30, 5-450TT
Shikishima	1	3	Shikishima	1900		15453t, 133.5x23.0x8.3m, 25b,2vte, 14500hp, 18kts, 836p; Harvey- 229belt, 102deck, 254turrets, 356CT; 2x2-305/40, 14x1-152/40, 20x1-76/40, 6x1-47/40, 6x1-47/30, 5-450TT
Asahi	1	4	Asahi	1900		15374t, 129.6x22.9x8.3m, 25b,2vte, 15000hp, 18kts, 830p; Harvey- 229belt, 102deck, 254turrets, 356CT; 2x2-305/40, 14x1-152/40, 20x1-76/40, 6x1-47/40, 6x1-47/30, 4-450TT

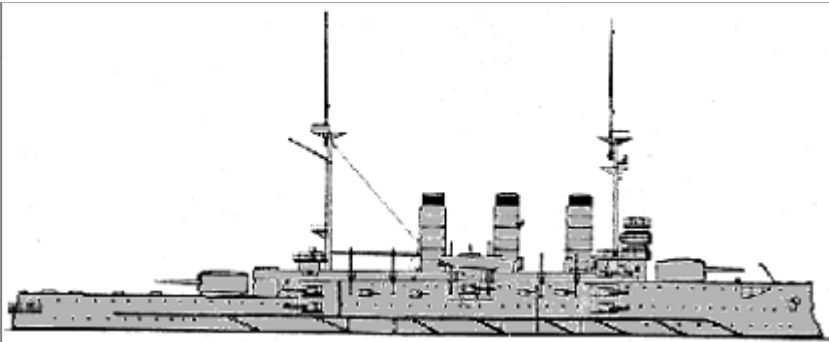
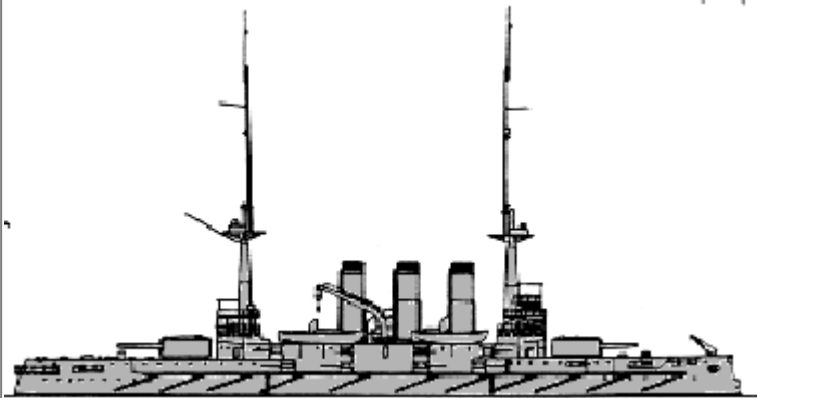
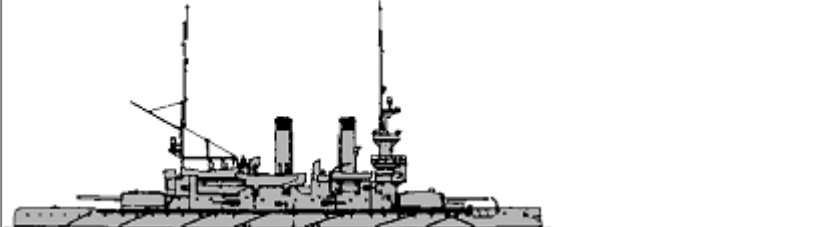
BB	Mikasa	1	5	Mikasa	1902		15179t, 131.7x23.2x8.3m, 25b,2vte, 15000hp, 18kts, 830p; Harvey- 229belt, 76deck, 254turrets, 356CT; 2x2-305/45, 14x1-152/45, 20x1-76/40, 8x1-47/40, 4x1-47/30, 4-450TT
	Iki	1	6	Iki	1891		9672t, 105.6x20.4x7.8m, 16b,2hte, 8500hp, 15.3kts, 616p; compound- 356belt, 63deck, 254turret, 203CT; 1x2-305/27, 6x1-152/40, 6x1-120/40, 6x1-76/40, 6-381TT
	Kashima	2	7	Kashima	1906		17200(7)-16663(8)t, 139.6(7)-139.0(8)x23.8x8.1(7)-8.2(8)m, 20b,2vte, 16600(7)-15800(8)hp, 18.5kts, 864p; 229belt, 51deck, 229turrets, 229CT; 2x2-305/45, 4x1-254/45, 10x1-152/45, 16x1-76/50, 3x1-47/40, 5-450TT
			8	Katori	1906		
	Iwami	1	9	Iwami	1904		15300t, 121.0x23.2x8.0m, 20b,2vte, 16300hp, 17.8kts, 806p; 190belt, 75deck, 254turrets, 203CT; 2x2-305/38, 6x1-203/45, 16x1-75/48, 4x1-47/40, 2-381TT
	Sagami	2	10	Sagami	1901		13500t, 133.4x21.8x7.9(10)-8.0(11)m, 32b,3vte(10)-30b,3vte(11), 15000hp, 18kts, 775p; 229belt, 76deck, 229turrets, 152CT; 2x2-254/42, 10x1-152/40, 16x1-76/40, 2-381TT
11			Suwo	1902			

							
	Hizen	1	12	Hizen	1901		12902t, 117.9x22.0x7.9m, 24b,2vte, 17000hp, 18kts, 791p; 229belt, 76deck, 229turrets, 254CT; 2x2-305/38, 12x1-152/43, 14x1-76/40, 2x1-47/40, 2-450TT
BC	Mishima	2	2	Mishima Okinoshima	1897 1899		5050t, 86.4x15.9x5.8m, 8b,2vte(1)-18b,2vte(2), 5750hp, 16kts, 404p; Harvey- 254belt, 76deck, 203turrets, 203CT; 2x2-254/42(1), (1x2+1x1)-254/42(2), 6x1-152/40(1), 6x1-120/40(2)

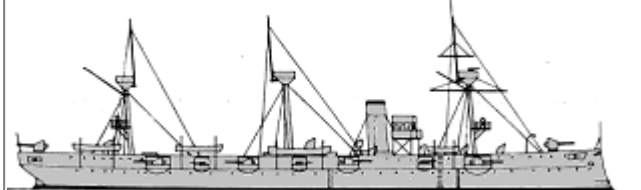
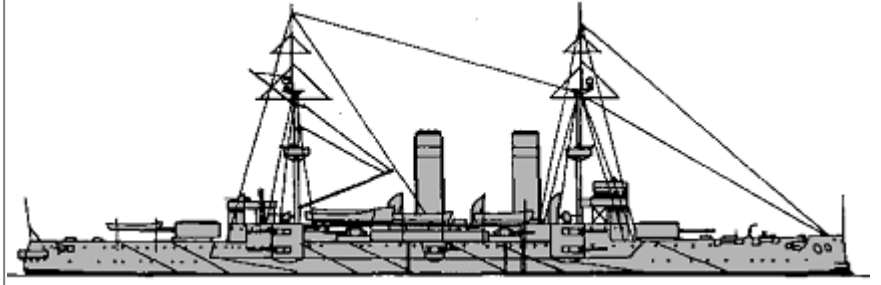
CRUISERS

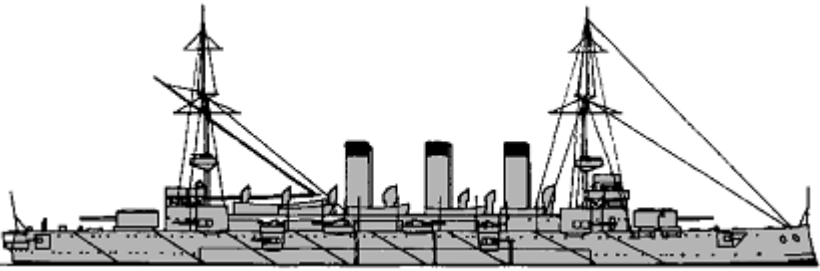
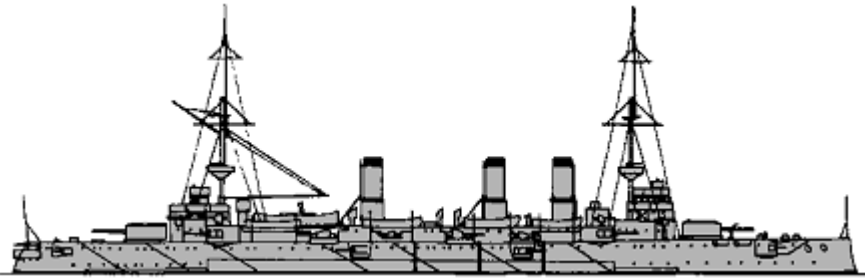
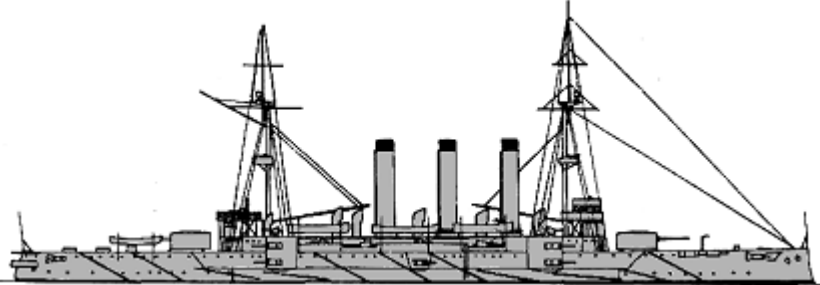
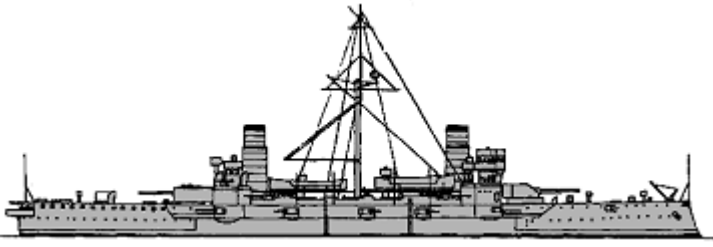
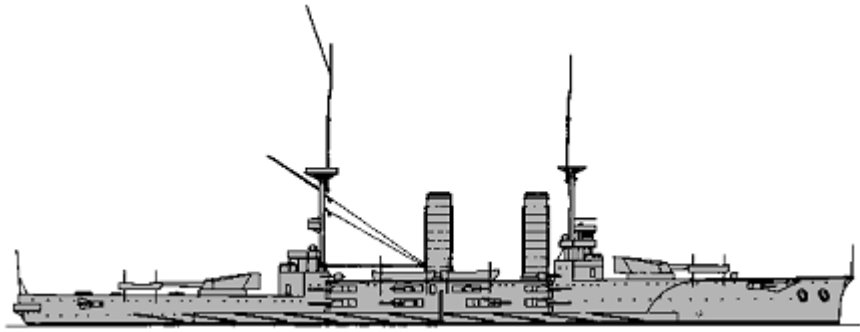

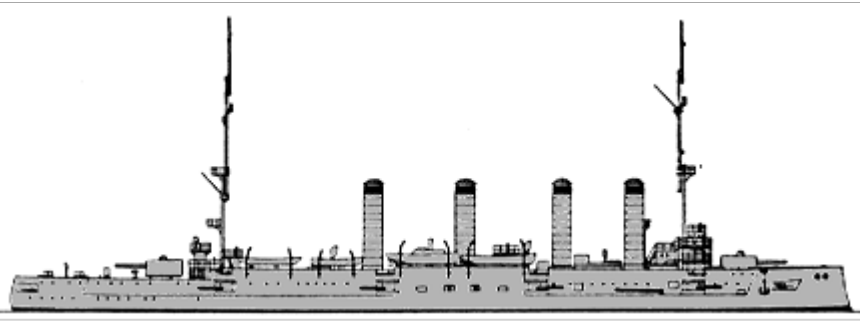
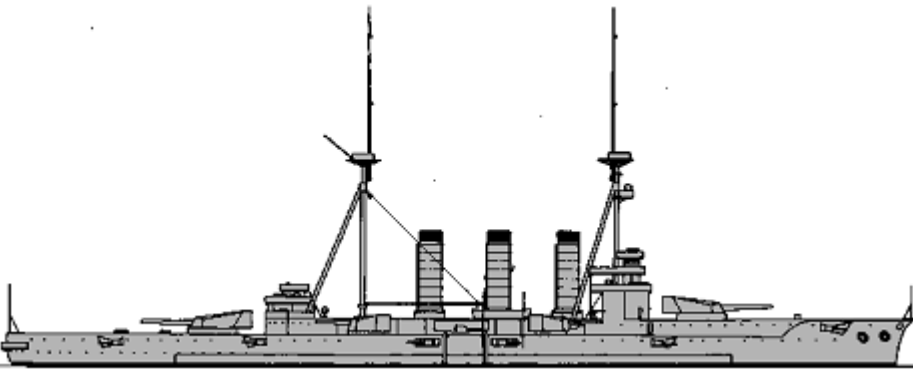
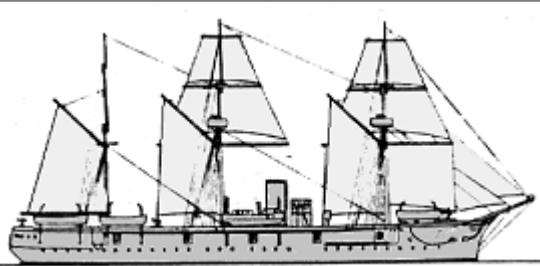
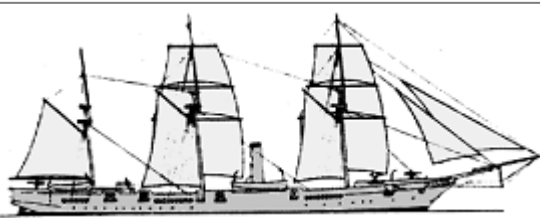
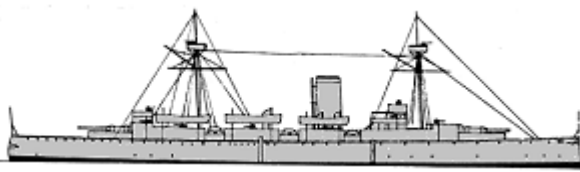
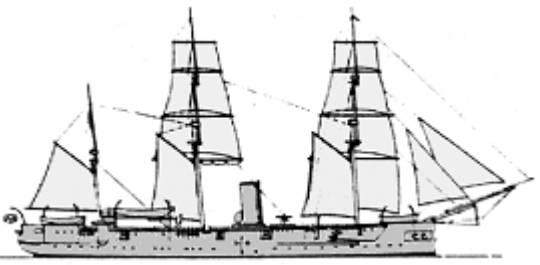

	Chiyoda	1	1	Chiyoda	1891		2439t, 94.5x12.8x4.3m, 12b,2vte, 5600hp, 19kts, 350p; compound- 92belt, 35deck, 30CT; 10x1-120/40, 14x1-47/40, 3x10-11.4/94, 3-350TT
	Asama	2	2	Asama	1899		10500t, 134.7x20.5x7.4m, 12b,2vte, 18000hp, 21.5kts, 726p; Harvey- 178belt, 76deck, 152turrets, 356CT; 2x2-203/45, 14x1-152/40, 12x1-76/40, 7x1-47/30, 5-450TT
			3	Tokiwa	1899		

CA	Yakumo	1	4	Yakumo	1900		10300t, 132.3x19.6x7.2m, 24b,2vte, 15500hp, 20.5kts, 700p; 178belt, 63deck, 152turrets, 356CT; 2x2-203/45, 12x1-152/40, 12x1-76/40, 7x1-47/30, 5-450TT
	Adzuma	1	5	Adzuma	1900		9953t, 137.9x20.9x7.2m, 24b,2vte, 17000hp, 20kts, 650p; 178belt, 63deck, 152turrets, 356CT; 2x2-203/45, 12x1-152/40, 12x1-76/40, 12x1-47/40, 5-450TT
	Idzumo	6	Idzumo	1900		10300t, 132.3x20.9x7.4m, 24b,2vte, 14500hp, 20.8kts, 672p; 178belt, 63deck, 152turrets, 356CT; 2x2-203/45, 14x1-152/40, 12x1-76/40, 8x1-47/30, 4-450TT	
		7	Iwate	1901		10300t, 132.3x20.9x7.4m, 24b,2vte, 14500hp, 20.8kts, 672p; 178belt, 63deck, 152turrets, 356CT; 2x2-203/45, 14x1-152/40, 12x1-76/40, 8x1-47/30, 4-450TT	
	Kasuga	8	Kasuga	1904		8500t, 111.7x18.9x7.3m, 12b,2vte, 13500hp, 20kts, 600p; 150belt, 38deck, 150turrets, 150CT; 1x1-254/40(8), 1x2-203/45(8), 2x2-203/45(9), 14x1-152/40, 10x1-76/40, 6x1-47/40(8), 4x1-47/40(9), 4-450TT	
		9	Nisshin	1904		8500t, 111.7x18.9x7.3m, 12b,2vte, 13500hp, 20kts, 600p; 150belt, 38deck, 150turrets, 150CT; 1x1-254/40(8), 1x2-203/45(8), 2x2-203/45(9), 14x1-152/40, 10x1-76/40, 6x1-47/40(8), 4x1-47/40(9), 4-450TT	
	Tsukuba	2	10	Tsukuba	1907		15400t, 137.1x22.8x8.0m, 20b,2vte, 20500hp, 20.5kts, 879p; 178belt, 76deck, 178turrets, 203CT; 2x2-305/45, 12x1-152/45, 12x1-120/40, 4x1-76/40, 3-450TT
		11	Ikoma	1908	15400t, 137.1x22.8x8.0m, 20b,2vte, 20500hp, 20.5kts, 879p; 178belt, 76deck, 178turrets, 203CT; 2x2-305/45, 12x1-152/45, 12x1-120/40, 4x1-76/40, 3-450TT		
Aso	1	12	Aso	1903		7800t, 137.0x17.5x6.5m, 26b,2vte, 16500hp, 21kts, 593p; Harvey- 200belt, 50deck, 100turrets, 160CT; 2x1-203/42, 8x1-152/45, 16x1-76/40	

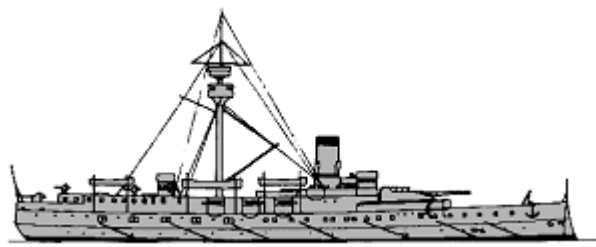
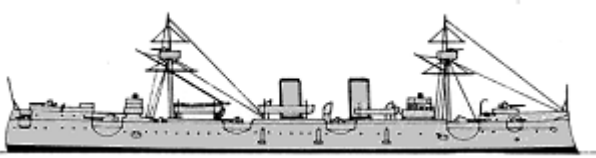
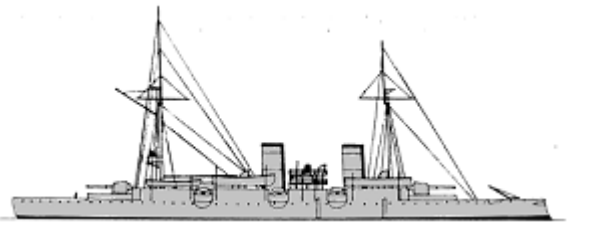
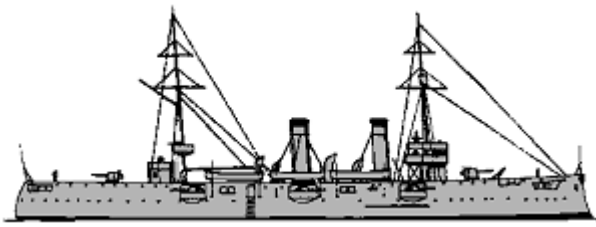
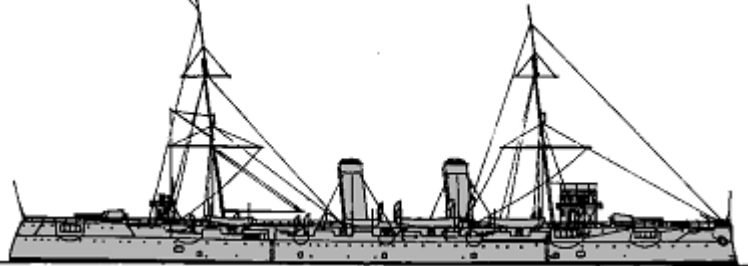
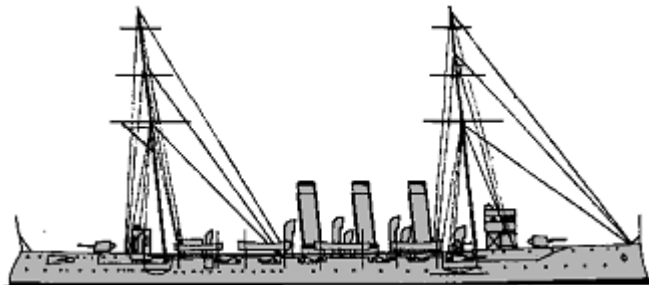
						
Ibuki	1	13	Ibuki	1909		15595t, 147.8x23.0x8.0m, 18b,2st, 24000hp, 21.5kts, 844p; 178belt, 76deck, 178turrets, 203CT; 2x2-305/45, 4x2-203/45, 14x1-120/40, 4x1-76/40, 3-450TT
Kongo	1	1	Hiei	1878		3718t, 70.5x12.5x5.5m, 2b,1hc, 2490hp, 14kts, 314p; compound- 114belt; 3x1-173/17, 6x1-149/22, 2x1-75/11, 2x1-47/40, 4x4-25/60, 2x5-11.4/94, 2-350TT
Kaimon	1	2	Tenryu	1884		1525t, 64.7x10.8x5.2m, 4b,1hcra, 1267hp, 12kts, 214p; 1x1-173/22, 1x1-149/22, 4x1-120/22, 1x1-79/25, 4x4-25/60
Naniwa	2	3	Naniwa	1885		3708t, 97.5x14.0x6.1m, 6b,2hc, 7000hp, 18.5kts, 325p; steel- 76deck, 51barbettes, 38CT; 8x1-152/40, 6x1-47/40, 4-350TT, mines(4)
		4	Takachiho	1886		
Katsuragi	3	5	Katsuragi	1887		1502t, 62.8x10.7x4.6m, 6b,1hcra, 1622hp, 13kts, 231p; 4x1-76/40, 4x1-47/30
		6	Yamato	1888		
		7	Musashi	1887		
		8	Itsukushima	1891		

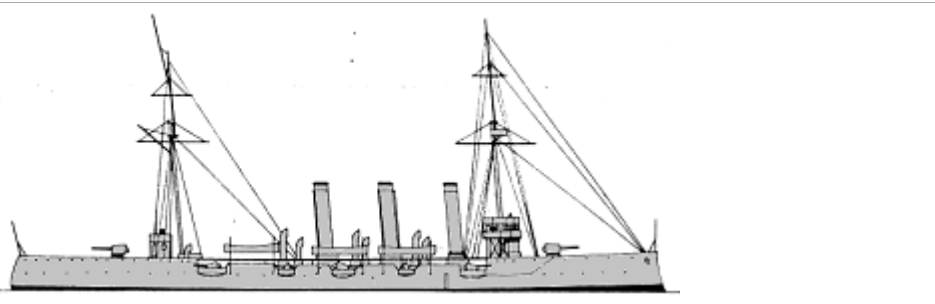
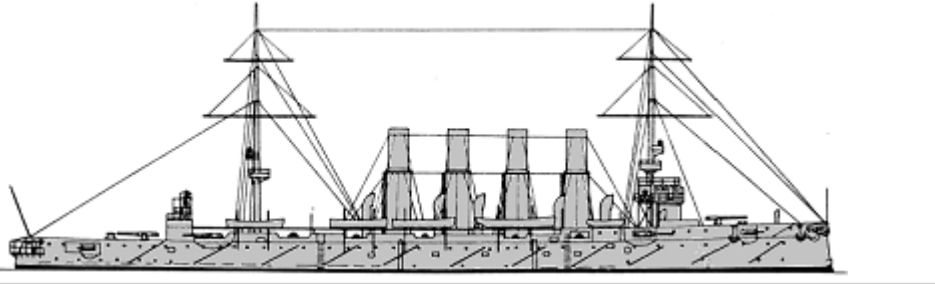
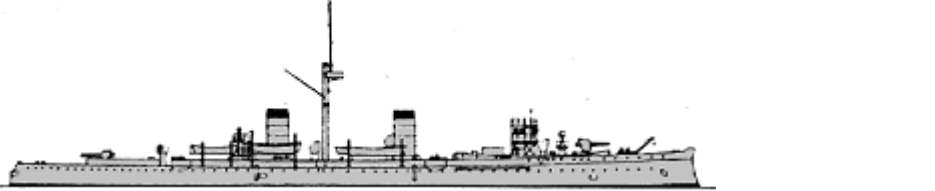

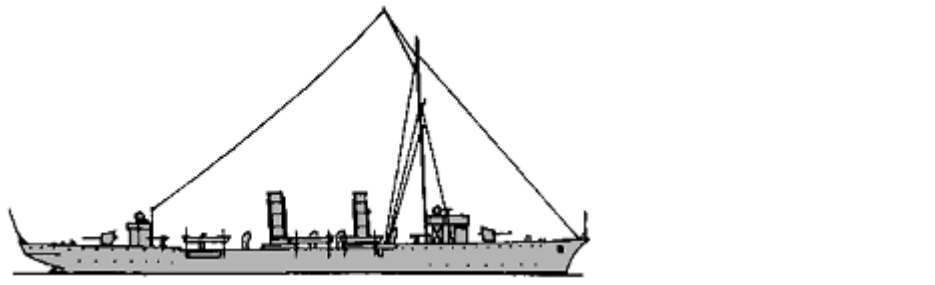

CL

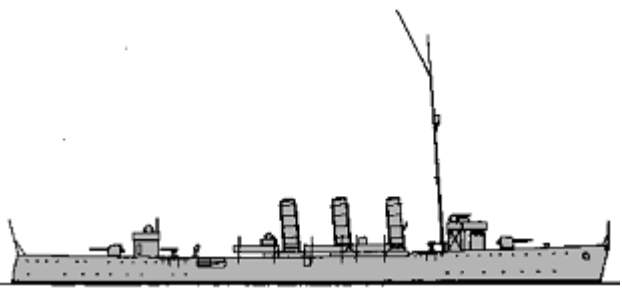

Itsukushima	2	9	Hashidate	1894		4217t, 99.8x15.4x6.0m, 8b,2hte, 5400hp, 16.5kts, 360p; Harvey- 40deck, 100turret, 125CT; 1x1-320/38, 11x1-120/40, 5x1-57/40(8), 6x1-57/40(9), 12x1-37/20(8), 11x1-37/20(9), 4-350TT
Akitsushima	1	10	Akitsushima	1894		3150t, 92.0x13.1x5.3m, 6b,2vte, 8400hp, 19kts, 314p; Harvey- 76deck, 114shields; 4x1-152/40, 6x1-120/40, 8x1-47/40, 4-350TT
Idzumi	1	11	Idzumi	1884		2920t, 82.3ppx12.8x5.6m, 12b,2hc, 6083hp, 18.2kts, 300p; compound- 25slopes, 13deck; 2x1-152/40, 6x1-120/40, 2x1-57/40, 6x1-47/40, 3-350TT
Suma	2	12	Suma	1896		2657(12)-2756(13)t, 95.0(12)-93.3(13)x12.2(12)-12.7(13)x4.6(12)-4.8(13)m, 4b,2vte(12)-9b,2vte(13), 8500hp, 20kts, 310p; Harvey- 51slopes, 25deck, 114shields; 2x1-152/40, 6x1-120/40, 10x1-47/40, 4x1-47/30, 2-380TT
		13	Akashi	1899		
Chitose	2	14	Chitose	1899		5598(14)-6066(15)t, 120.4(14)-121.5(15)x15.0(14)-14.9(15)x5.4m, 8b,2vte, 15000hp, 22.5kts, 434(14)-405(15)p; Harvey- 114slopes, 45deck, 114shields, 114CT; 2x1-203/45, 10x1-120/40, 12x1-76/40, 6x1-47/30, 5-350TT
		15	Kasagi	1898		
Tsushima	2	16	Niitaka	1904		3716t, 104.1x13.4x4.9m, 16b,2vte, 9500hp, 20kts, 320p; 64slopes, 38deck, 25shields, 102CT; 6x1-152/40, 10x1-76/40, 4x1-47/30
		17	Tsushima	1904		
Otowa	1	18	Otowa	1904		3000t, 103.9x12.6x4.8m, 10b,2vte, 10000hp, 21kts, 312p; Harvey- 76slopes, 76deck, 38shields, 102CT; 2x1-152/40, 6x1-120/40, 4x1-76/40, 2-450TT



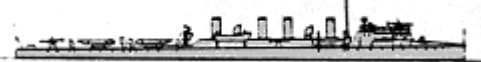
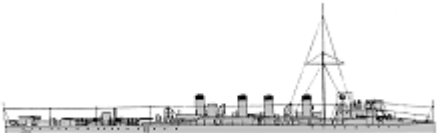

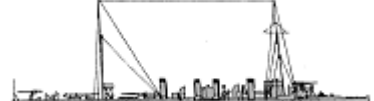

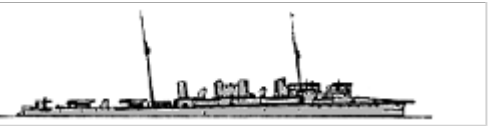

						
	Soya	1 19	Soya	1901		6500t, 129.8x15.9x6.3m, 30b,2vte, 21000hp, 23.2kts, 580p; 76slopes, 38deck, 152CT; 12x1-152/43, 10x1-75/48, 2x1-47/30, 2-381TT
	Suzuya	1 20	Suzuya	1901		3080t, 110.5x12.2x5.0m, 6b,3vte, 6000hp, 20kts, 337p; 51slopes, 38deck, 25shields, 30CT; 2x1-120/40, 4x1-76/40, 6x1-47/40, 2x5-37/20
CLL	Takao	1 1	Takao	1889		1927t, 71.1x10.4x4.0m, 5b,2hc, 2330hp, 15kts, 229p; 4x1-152/40, 2x1-47/40, 2-450TT
	Tatsuta	1 2	Tatsuta	1894		850t, 73.1ppx8.4x2.9m, 4b,2vte, 5500hp, 21kts, 100p; 2x1-120/40, 4x1-76/40, (1+2x2)-450TT
	Chihaya	1 3	Chihaya	1901		1464t, 87.7x9.6x2.8m, 4b,2vte, 6000hp, 21kts, 125p; 2x1-120/40, 4x1-76/40, 2x1-450TT
	Yodo	1 4	Yodo	1908		1250t, 93.1x9.8x3.0m, 4b,2vc, 6500hp, 22kts, 180p; 63slopes, 63deck, 51CT; 2x1-120/40, 4x1-76/40, 2x1-450TT

	Mogami	1	5	Mogami	1908		1350t, 96.3x9.8x3.0m, 6b,3st, 8000hp, 23kts, 180p; 63slopes, 63deck, 51CT; 2x1-120/40, 4x1-76/40, 2x1-450TT
--	--------	---	---	--------	------	---	---

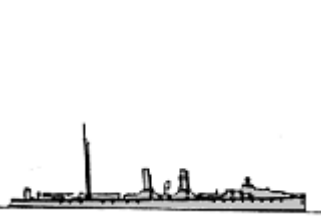

TORPEDO SHIPS

PGT	Makigumo	2	1	Makigumo	1894		432t, 60.2x7.4x3.5m, 2b,1vte, 3000hp, 22kts, 64p; 6x1-47/40, 3x1-37/20, (1+1x1)-381TT
			2	Shikinami	1894		
Murakumo	6	6	1	Kagero	1899		361t, 65.7x6.0x1.7m, 3b,2vte, 5800hp, 30kts, 54p; 2x1-76/40, 4x1-57/40, 2x1-450TT
			2	Murakumo	1898		
			3	Shinonome	1899		
			4	Shiranui	1899		
			5	Usugumo	1900		
			6	Yugiri	1899		
Ikazuchi	4	4	7	Ikazuchi	1899		410t, 68.5x6.3x1.6m, 4b,2vte, 6000hp, 31kts, 55p; 2x1-76/40, 4x1-57/40, 2x1-450TT
			8	Akebono	1899		
			9	Oboro	1899		
			10	Sazanami	1899		
Akatsuki	1	11	Kasumi	1902		415t, 68.5x6.3x1.7m, 4b,2vte, 6000hp, 31kts, 60p; 2x1-76/40, 4x1-57/40, 2x1-450TT	
Shirakumo	2	2	12	Shirakumo	1902		428t, 67.5x6.3x1.8m, 4b,2vte, 7000hp, 31kts, 59p; 2x1-76/40, 4x1-57/40, 2x1-450TT
			13	Asashio	1902		
Harusame	6	6	14	Asagiri	1903		435t, 71.4x6.6x1.8m, 4b,2vte, 6000hp, 29kts, 55p; 2x1-76/40, 4x1-57/40, 2x1-450TT
			15	Harusame	1903		
			16	Murasame	1903		
			17	Ariake	1905		
			18	Arare	1905		
			19	Fubuki	1905		
Akatsuki	2	2	20	Yamabiko	1902		305t, 61.0x5.7x2.4m, 8b,2vte(20)-4b,2vte(21), 3800hp, 27kts, 58p; 1x1-75/48, 3x1-47/40, 2x1-381TT
			21	Fumizuki	1903		
Satsuki	1	22	Satsuki	1902		480t, 64.0x6.4x2.6m, 4b,2vte, 5700hp, 26kts, 75p; 5x1-47/40, 2x1-450TT	

DD	Asakaze	32	23	Asakaze	1906		
			24	Wakaba	1906		
			25	Ushio	1905		
			26	Nenohi	1905		
			27	Kisaragi	1905		
			28	Kamikaze	1905		
			29	Hatsushimo	1905		
			30	Yugure	1906		
			31	Harukaze	1906		
			32	Yayoi	1905		
			33	Oite	1906		
			34	Hibiki	1906		
			35	Hatsuyuki	1906		
			36	Yudachi	1906		
			37	Asatsuyu	1906		
			38	Nowaki	1906		450t, 72.0x6.6x1.8m, 4b,2vte, 6000hp, 29kts, 70p; 2x1-76/40, 4x1-76/23, 2x1-450TT
			39	Mikazuki	1906		
			40	Shigure	1906		
			41	Hatsuharu	1907		
			42	Shiratsuyu	1906		
			43	Shirayuki	1906		
			44	Shirotae	1907		
			45	Matsukaze	1907		
			46	Nagatsuki	1907		
			47	Yunagi	1906		
			48	Uzuki	1907		
			49	Minazuki	1907		
			50	Hayate	1907		
			51	Kikuzuki	1907		
			52	Uranami	1908		
			53	Isonami	1909		
			54	Ayanami	1909		
	Shirataka	1	1	Shirataka	1900		
			2	Chidori	1901		
			3	Hayabusa	1900		
			4	Kasasagi	1900		

TB1	Hayabusa	15	5	Manazuru	1900		150t, 46.4x4.9x1.5m, 2b,2vte, 4200hp, 29kts, 30p; 1x1-57/40, 2x1-47/30, (1+2x1)-450TT					
			6	Aotaka	1903							
			7	Uzura	1904							
			8	Hashitaka	1904							
			9	Hato	1903							
			10	Hibari	1904							
			11	Kamome	1904							
			12	Kari	1903							
			13	Kiji	1904							
			14	Otori	1904							
			15	Sagi	1904							
			16	Tsubame	1903							
			TB2	22-go	1			1	25-go	1895		85t, 39.0ppx4.8x1.1m, 1b,1vte, 990hp, 19kts, 20p; 2x1-47/30, 3x1-350TT
				21-go	2			2, 3	21-go, 24-go	1894 - 1895		80t, 36.0ppx4.0x1.2m, 1b,1vte, 1150hp, 21kts, 21p; 1x1-47/30, 3x1-350TT
				29-go	2			4, 5	29-go, 30-go	1900		88t, 37.0ppx4.1x1.2m, 2b,1vte, 2000hp, 22.5kts, 20p; 1x1-47/40, (1+2x1)-350TT
				31-go	13			6 - 18	31-go-33-go, 36-go-38-go, 44-go-47-go, 49-go, 60-go, 61-go	1900 - 1901		89t, 39.0ppx4.8x1.1m, 2b,1vte, 1200hp, 24kts, 20p; 2x1-47/30, (1+2x1)-350TT
39-go	9	19		39-go	1901		102t, 46.5x4.7x1.6m, 2b,1vte, 1920hp, 26kts, 20p; 2x1-47/40, 3x1-350TT					
		20		40-go	1901							
		21		41-go	1901							
		22		43-go	1901							
		23		62-go	1902							
		24		63-go	1902							
		25		64-go	1902							
		26		65-go	1902							
27	66-go	1902										
67-go	8	28 - 35	67-go, 68-go, 70-go-75-go	1903 - 1904		89t, 40.1x4.9x1.3m, 2b,1vte, 1200hp, 23.5kts, 24p; 2x1-47/40, (1+2x1)-350TT						
TB3	5-go	7	1 - 7	10-go-13-go, 17-go-19-go	1892 - 1894		54t, 35.0x3.4x0.9m, 1b,1hc, 525hp, 20kts, 16p; 1x1-47/30, (1+1x1)-350TT					
	15-go	1	8	20-go	1894		54t, 35.0x3.5x1.0m, 1b,1vte, 657hp, 20kts, 20p; 1x1-47/30, 1x2-350TT					
	50-go	7	9 - 15	50-go, 52-go, 54-go-58-go	1900 - 1902		54t, 34.0x3.5x1.0m, 1b,1vte, 660hp, 20kts, 16p; 1x1-47/40, 1x2-350TT					

SUBMARINES

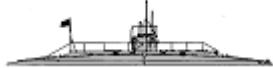
SS	Holland	5	1	1-go	1905		103/124t, 20.4x3.6x3.1m, 1pe/em, 180/70hp, 8/7kts, 13p, 30m; 1-450TT
			2	2-go	1905		
			3	3-go	1905		
			4	4-go	1905		
			5	5-go	1905		
	Kaigun-Holland	2	6, 7	6-go, 7-go	1906		78/95(6)-57/63(7)t, 25.7(6)-22.5(7)x2.4(6)-2.1(7)x2.3(6)-2.0(7)m, 1pe/em, 300/22hp, 8.5/4kts, 14p, 30m; 1-450TT
C1		2	8	8-go	1909		286/321t, 43.3x4.1x3.4m, 1pe/em, 600/300hp, 12/8.5kts, 26p, 30m; 2-450TT
			9	9-go	1909		

OTHER FIGHTING SHIPS

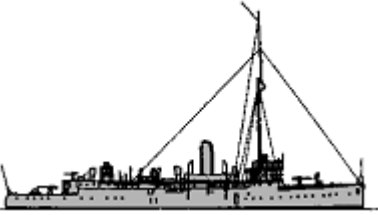
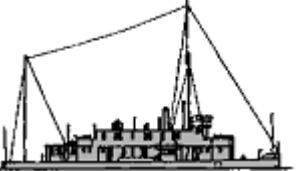
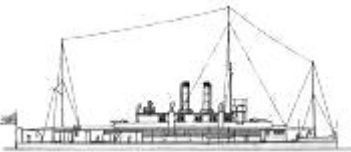
PG	Banjo	1	1	Banjo	1880	No picture	708t, 46.9x7.9x3.9m, 4b,1hc, 659hp, 10kts, 112p; 1x1-149/22, 1x1-120/22, 2x1-79/25, 3x4-25/60
	Maya	3	2	Maya	1888		622t, 46.8ppx8.2x3.1m, 2b,2hcda, 963hp, 12kts, 104p; 1x1-209/19(3), 4x1-120/40(2,4), 1x1-120/22(3), 2x1-57/43(2), 2x1-47/40(2), 4x1-47/40(4), 2x4-25/60
			3	Chokai	1888		
			4	Akagi	1890		
Uji	1	5	Uji	1903			
PGR	Sumida	1	1	Sumida	1906		126t, 44.2ppx7.2x0.6m, 2b,3vte, 550hp, 13kts, 40p; 2x1-47/40
	Fushimi	1	2	Fushimi	1906		180t, 48.7ppx7.4x0.7m, 2b,3vte, 900hp, 14kts, 45p; 2x1-57/40

[home](#)

[World navies yesterday](#)

[1910](#)

Liberia 01 January 1910

ESCORTS



AY	-	1	1	Lark	1876		770t
----	---	---	---	------	------	--	------

© Ivan Gogin, 2015

[home](#)[World navies yesterday](#)[1910](#)

Mexico 01 January 1910

CRUISERS

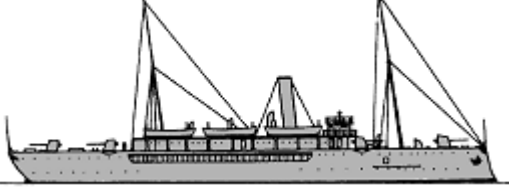
CL	Porfirio Díaz	1	1	Porfirio Díaz	1892		1200t, 68.0x9.3x4.3m, 2b,1vte, 1300hp, 15kts, 270p; 4x1-120/40, 2x1-57/40
CP	Progreso	1	1	Progreso	1907		1700t, 70.1x10.3x3.0m, 1vte, 1400hp, 13kts, 140p; 4x1-57/40; troops
	Vincente Guerrero	1	2	Vincente Guerrero	1908		1850t, 74.6ppx13.2x5.3m, 1vte, 1500hp, 12kts, 300p; 6x1-102/40, 2x1-47/50; 550troops, 45horses

OTHER FIGHTING SHIPS

PG	Independencia	1	Independencia	1874		480t, 38.1x7.3x2.7m, 1hc, 425hp, 10kts, 63p; 1x1-163/16, 4x1-95/21
		2	Libertad	1874		
	Democrata	3	Democrata	1875		445t, 42.7x7.6x3.4m, 600hp, 11kts, 80p; 2x1-163/16, 2x1-107/19
		4	Mexico	1875		
Tampico	2	5	Tampico	1902		980t, 61.0ppx10.1x3.4m, 2vte, 2400hp, 16kts, 98p; 2x1-102/40, 6x1-57/40, 1-356TT, 200troops
	6	Vera Cruz	1902			

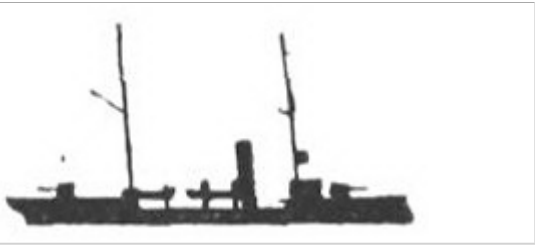
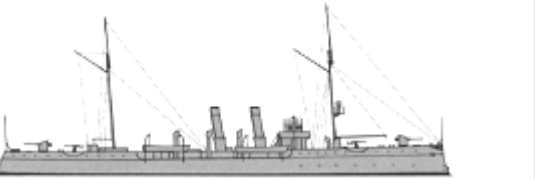

					
Nicholas Bravo	2	7 Nicholas Bravo	1904		1493t, 73.8x10.4x3.0m, 2vte, 2565hp, 17kts, 116p; 2x1-102/40, 6x1-57/40, 1-356TT
		8 Morales	1904		

© Ivan Gogin, 2015

[home](#)[World navies yesterday](#)[1910](#)

Netherlands 01 January 1910

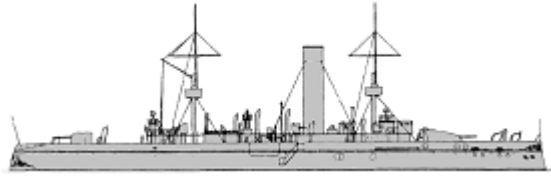
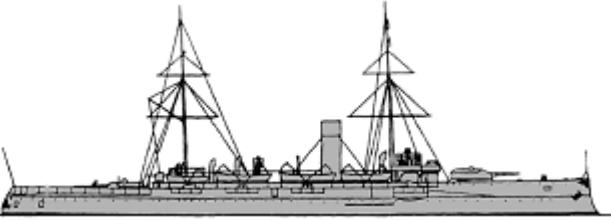
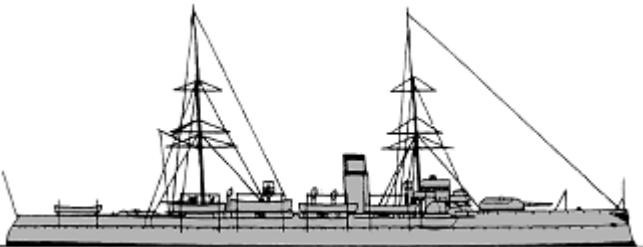
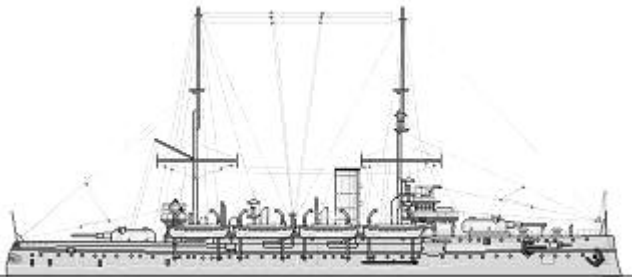

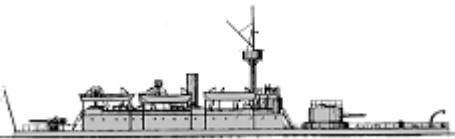

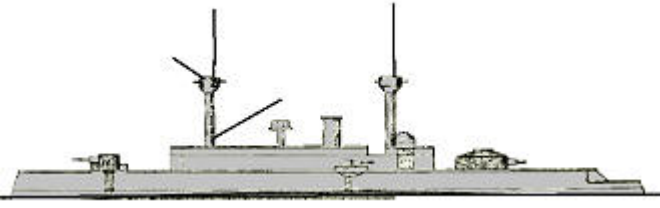
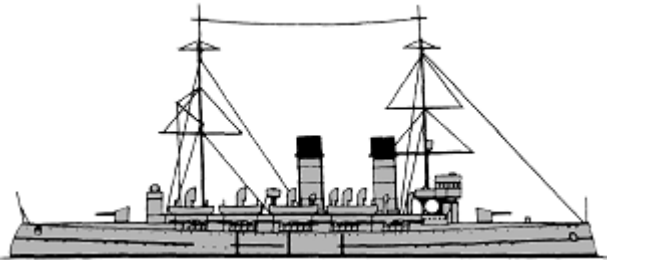

BATTLESHIPS



BC	Evertsen	1	Evertsen	1896		3464t, 86.2x14.3x5.2m, 6b,2vte, 4700hp, 16kts, 263p; steel- 150belt, 55deck, 240barbette, 240CT; (1x2+1x1)-209/32, 2x1-149/32, 6x1-75/27, 8x1-37/20, 3-450TT
		2	Piet Hein	1896		
		3	Kortenaer	1895		
	Koningin Regentes	4	Koningin Regentes	1901		5002(4,5)-5084(6)t, 96.6x15.2x5.8m, 6b,2vte, 6500hp, 16.5kts, 340p; 150belt, 50deck, 100turrets, 250CT; 2x1-238/37, 4x1-149/37, 8x1-75/37, 4x1-37/20, 3-450TT
5		De Ruyter	1902			
6		Hertog Hendrik	1904			
BC	Marten Harpertzoon Tromp	1	Marten Harpertzoon Tromp	1905		5295t, 100.8x15.2x5.7m, 8b,2vte, 6400hp, 16.5kts, 340p; 150belt, 50deck, 100turrets, 195CT; 2x1-238/37, 4x1-149/37, 8x1-75/37, 4x1-37/20, 3-450TT
		7	Marten Harpertzoon Tromp	1905		
BC	Jacob van Heemskerck	1	Jacob van Heemskerck	1908		4920t, 98.0x15.2x5.7m, 8b,2vte, 6400hp, 16.5kts, 340p; 150belt, 50deck, 100turrets, 195CT; 2x1-238/37, 6x1-149/37, 6x1-75/37, 4x1-37/20, 2-450TT
MON	Draak	1	Draak	1878		2198t, 65.1x15.0x3.6m, 4b,2hc, 807hp, 8.4kts, 131p; iron- 205side, 23deck, 305turret, 140CT; 1x2-283/20, 2x1-37/20, 2x5-37/17
	Reinier Claeszen	1	Reinier Claeszen	1894		2440t, 70.0x13.5x4.6m, 3b,2vc, 2315hp, 12.5kts, 161p; compound- 120belt, 75deck, 280turret, 280CT; 1x1-209/32, 1x1-173/32, 4x1-50/37, 2-356TT

CRUISERS

CL	Koningin Wilhelmina der Nederlanden	1	1	Koningin Wilhelmina der Nederlanden	1894		4530t, 99.8x14.9x6.1m, 6b,2vte, 4600hp, 15.8kts, 296p; compound- 75slopes, 50deck, 280turret; 1x1-283/27, 1x1-209/32, 2x1-173/32, 4x1-75/37, 6x1-37/20, 4x5-37/17, 4-356TT
	Holland	6	2	Holland	1898		3840(2-4)-3970(5-7)t, 93.3(2-4)-94.7(5-7)x14.8x5.4m, 8b,2vte(2-4)-10b,2vte(5-7), 10000hp, 20kts, 371p; Harvey- 57deck, 152shields, 102CT; 2x1-149/37, 6x1-120/37, 6x1-75/37, 8x1-37/20, 4x5-37/17, 2-450TT
			3	Zeeland	1898		
			4	Friesland	1898		
			5	Gelderland	1900		
			6	Noord Brabant	1900		
	7	Utrecht	1900				
CLL	Sommelsdijk	1	1	Sommelsdijk	1882	No picture	997t, 54.5x9.5x3.6m, 759hp, 11.4kts, 96p; 1x1-149/22, 3x1-120/16, 2x1-37/20, 2x5-37/17

TORPEDO SHIPS

TB1cl	Ardjoeno	10	1-10	Ardjoeno, Dempo, Habang, Krakatau, Cycloop, Batok, Foka, Idjen, Empong, Goentoer	1887-1892		79-90t, 38.4-39.2x4.0x1.8-2.1m, 1b,1vc, 725-1089hp, 19.1-22.8kts, 16p; 2x1-37/20, 2-450TT
	No.XXIII	1	11	Cerberus	1888		82t, 38.2x4.0x1.8m, 1b,1vc, 912hp, 21.2kts, 16p; 2x1-37/20, (1+2x1)-450TT
	Lamongan	3	12-14	Lamongan, Nobo, Makjan	1891	No picture	59t, 32.9x4.0x1.6m, 1b,1vc, 780hp, 20.4kts, 15p; 2x1-37/20, 2-450TT
	Hydra	5	15	Hydra	1900		103t, 39.6x4.1x2.1m, 2b,1vte, 1500hp, 24kts, 21p; 2x1-37/20, 3x1-450TT
			16	Scylla	1900		
			17	Minotaurus	1902		
			18	Python	1902		
			19	Sphinx	1903		
	Ophir	6	20	Ophir	1901		140t, 46.6x4.7x2.4m, 2b,1vte, 2000hp, 25kts, 25p; 2x1-50/37, 3x1-450TT
			21	Pangrango	1901		
			22	Rindjani	1901		
			23	Smeroe	1903		
			24	Tangka	1903		
			25	Wajang	1903		
	G1	4	26	G1 Johan van Brakel	1905		145t, 46.6x4.7x2.3m, 2b,1vte, 2000hp, 25kts, 25p; 2x1-50/37, (1+2x1)-450TT
			27	G2 Jan Danielzoon van der Rijn	1905		
			28	G3 Meijndert Jentjes	1905		
			29	G4 Willem Willemsze	1905		
	Draak	3	30	Draak	1907		103t, 39.6x4.1x2.2m, 2b,1vte, 1500hp, 24kts, 21p; 2x1-37/20, (1+1x1)-450TT
			31	Krokodil	1907		
32			Zeeslang	1907			

TB2cl	No.XIII	1	1	No.XVII	1880		30t, 24.6x3.2x1.6m, 1b,1hda, 250hp, 17-18kts, 11p; 2spar torpedoes
	No.XXI	2	2, 3	Hekla, Etna	1882		45t, 31.0x3.8x1.7m, 1b,1hc, 550hp, 21.4kts, 15p; 2x1-37/20, 2-356TT
	No.III	3	4-6	No.III Jan Haring, No.XXI Jasper Leynssen, No.XXII Jacob Hobein	1891		37t, 25.6x3.2x1.6m, 1b,1vc, 440hp, 17.5kts; 2x1-37/20, 2-356TT
	K1	3	7-9	K1 Michiel Gardeyn, K2 Christiaan Cornelis, K3 Willem Warmont	1905	No picture	47t, 30.0x3.6x1.7m, 1b,1vte, 560hp, 18.7kts, 12p; 2x1-37/20, 2-356TT



SUBMARINES

SS	O1	1	1	O1	1906		105/124t, 20.4x4.9x2.8m, 1pe/em, 160/80hp, 9/6kts, 10p, 25m; 1-250TT
----	----	---	---	----	------	---	--

ESCORTS

AFPV	-	2	1	Dolfijn	1889		
			2	Zeehond	1892		

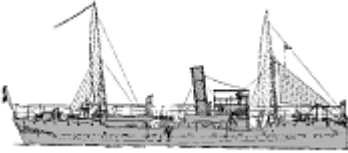
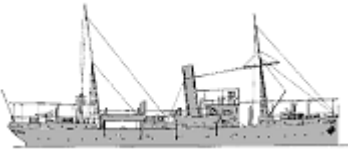
OTHER FIGHTING SHIPS

PG	Lombok	2	1	Lombok	1891	No picture	600t, 52.4x8.3x3.4m, 960hp, 12.3kts, 87p; 3x1-120/16, 2x1-37/20			
			2	Sumbawa	1891					
	Borneo	1	3	3	Borneo	1892	No picture	800t, 53.8x9.5x4.1m, 1040hp, 13.2kts, 102p; 6x1-105/32, 2x1-37/20, 2x5-37/17		
				Nias	3	4			Mataram	1896
						5			Edi	1897
	Koetei	3	6	6	Serdang	1897		810-820t, 53.9x9.4x3.7m, 2vte, 1300hp, 12.9kts, 97p; 2x1-105/32, 4x1-37/20, 2x5-37/17		
				Koetei	3	7			Koetei	1898
						8			Siboga	1898
	Hydra	6	9	9	Assahan	1900		788t, 53.7x9.4x3.7m, 2vte, 1380hp, 13.7kts, 97p; 2x1-105/32, 4x1-37/20, 2x5-37/17		
				Wodan	13	10			Ever	1873
						11			Das	1876
						12			Gier	1875
						13			Havik	1874
						14			Lynx	1875
	Wodan	13	15	15	Sperwer	1875		221t, 25.9x8.0x2.2m, 2b,1vc, 124-146hp, 7.5-8kts, 34p; 1x1-209/32, 2x1-37/20, 1x5-37/20		
				16	Wodan	1877				
				17	Balder	1879				
				18	Braga	1879				
				19	Freyr	1877				
				20	Heimdall	1879				
				21	Njord	1878				
	22	Thor	1877							
	23	Tyr	1878							
							264-280t, 27.8x8.2x2.3m, 2b,1vc, 101-171hp, 7-8.3kts, 34p; 1x1-283/27(24,26-28), 1x1-283/20(17-23,25), 1x1-120/37(16), 2x1-37/20, 1x5-37/17			

			24	Hefring	1880		
			25	Vidar	1879		
			26	Bulgia	1884		
			27	Dufa	1879		
			28	Udur	1879		
PR	Isala	1	1	Rhenus	1877	No picture	373-388t, 48.6x7.6x1.4m, 306-400hp, 7.7-8kts, 44p; iron- 125side, 25deck, 125turrets; 2x1-120/16

MINE WARFARE SHIPS

ML	Wodan	1	1	Hadda	1880		264-280t, 27.8x8.2x2.3m, 2b,1vc, 101-171hp, 7-8.3kts, 34p; 2x1-37/20, 1x5-37/17, mines
----	-------	---	---	-------	------	---	--

Google
Custom Search

© Ivan Gogin, 2014

[home](#)

[World navies yesterday](#)

[1910](#)

New Zealand 01 January 1910

OTHER FIGHTING SHIPS

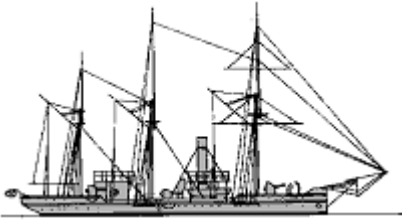
PG	Redbreast	1	1	Amokura (TS)	1890		805t, 50.3ppx9.5x3.4m, 2b,1vte, 1200hp, 13kts, 76p; 6x1-102/27, 2x1-47/40, 2x1-11.4
----	-----------	---	---	--------------	------	--	---





Custom Search

© Ivan Gogin, 2014

[home](#)[World navies yesterday](#)[1910](#)

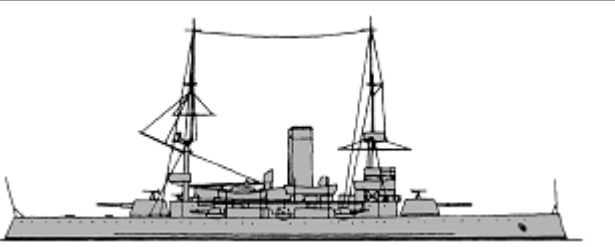
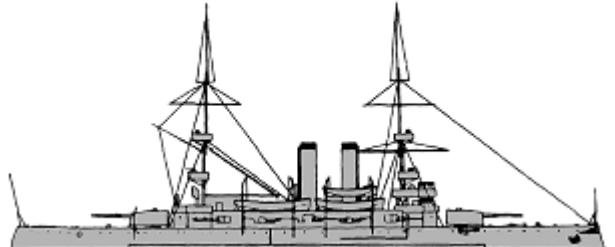
Norway 01 January 1910







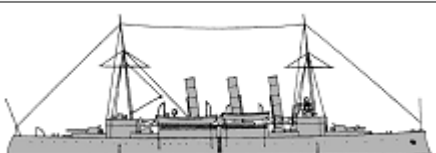



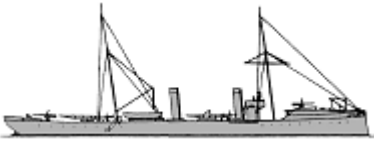
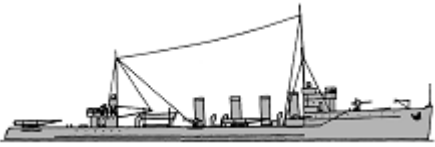



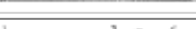

BATTLESHIPS

BC	Harald Haarfagre	1	Harald Haarfagre	1898		3858t, 92.7x14.8x5.4m, 3b,2vte, 4000hp, 16.9kts, 245p; Harvey- 178belt, 51deck, 203turrets, 152CT; 2x1-209/44, 6x1-120/44, 6x1-76/40, 6x1-37/45, 2-450TT
		2	Tordenskjold	1898		
Norge	Norge	3	Norge	1901		4166t, 94.6x15.4x5.4m, 6b,2vte, 4500hp, 16.5kts, 266p; 152belt, 51deck, 203turrets, 152CT; 2x1-209/44, 6x1-149/46, 8x1-76/40, 4x1-47/46, 2-450TT
		4	Eidsvold	1901		
MON	Mjølnar	1	Thrudvang	1869		1539t, 62.3x13.9x3.5m, 4b,1vle, 450hp, 8kts, 84p; iron- 125side, 25deck, 305turret; 1x2-120/44, 2x1-65/50, 2x1-37/40
	Thor	1	Thor	1876		2035t, 62.3x14.5x3.8m, 4b,1vle, 600hp, 8kts, 94p; iron- 175side, 25deck, 365turret; 1x2-120/44, 2x1-65/50, 2x1-37/40

CRUISERS

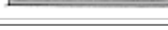
CL	Viking	1	Viking	1891		1181t, 63.5x9.3x3.7m, 4b,2vc, 2000hp, 15kts, 125p; Harvey- 35deck, 25shields, 35CT; 1x1-149/46, 1x1-120/44, 4x1-76/40, 2x1-75/37, 6x1-47/40, 1-356TT
	Frithjof	1	Frithjof	1896		1427t, 68.2x10.0x4.0m, 6b,2vte, 2800hp, 15kts, 154p; Harvey- 30deck; 2x1-120/44, 4x1-76/40, 4x1-37/45, 1-450TT

TORPEDO SHIPS

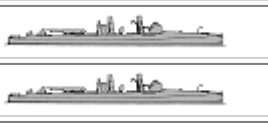
DD	Valkirjen	1	1	Valkirjen	1896		415t, 59.4x7.4x2.6m, 2b,2vte, 3300hp, 23kts, 59p; 2x1-76/40, 4x1-37/45, 2x1-450TT
	Draug	1	2	Draug	1909		578t, 69.2x7.3x2.9m, 4b,2vte, 7500hp, 26.5kts, 76p; 6x1-76/40, 3x1-450TT
TB1cl	Hval	3	1	Hval	1896		102t, 39.9x4.8x2.2m, 2b,1vte, 1100hp, 21kts, 23p; 2x1-37/45, 2x1-450TT
			2	Delfin	1896		
			3	Hai	1896		
	Storm	3	4	Storm	1898		107t, 39.9x4.8x2.2m, 2b,1vte, 1100hp, 21kts, 23p; 2x1-37/45, 2x1-450TT
			5	Brand	1898		
			6	Trods	1898		
	Laks	4	7	Laks	1900		107t, 38.5x4.8x2.2m, 2b,1vte, 1150hp, 21kts, 23p; 2x1-37/45, 2x1-450TT
			8	Sild	1900		
			9	Sæl	1901		
			10	Skrei	1901		
TB2cl	Rap	1	1	Rap	1873		15t, 17.3x2.3x0.9m, 1b,1hda, 90hp, 15kts, 6p
	Ulven	1	2	Ulven	1878		16t, 17.2x2.9x1.1m, 1b,1hda, 70hp, 10kts, 6p
	Od	1	3	Od	1882		41t, 29.0xxm, 1b,1vc, 420hp, 18kts; 1x1-37/20, 1-356TT
	Springer	1	4	Springer	1883		44t, 30.0xxm, 1b,1vc, 420hp, 18kts; 1x1-37/20, 2-356TT
	Rask	2	5, 6	Rask, Pil	1885-1886		44t, 30.5xxm, 1b,1vc, 500hp, 19kts; 1x1-37/20, 2-356TT
	Snar	1	7	Snar	1887		49t, 32.0xxm, 2b,1vc, 600hp, 19kts; 1x1-37/20, 2-356TT
	Orm	2	8, 9	Orm, Oter	1888		54t, 33.0xxm, 2b,1vc, 600hp, 19kts; 1x1-37/20, 2-381TT
	Varg	2	10, 11	Varg, Raket	1894		64t, 34.5x3.8x1.6m, 2b,1vte, 650hp, 19kts, 12p; 1x5-37/12, 2-450TT
	Lyn	3	12-14	Lyn, Blink, Glimt	1896-1897		64t, 34.5x3.8x1.8m, 2b,1vte, 650hp, 19kts, 21p; 1x1-37/45, (1+1x1)-450TT
	Djerv	3	15-17	Djerv, Kvikk, Dristig	1897-1898		66t, 34.5x3.8x1.7m, 2b,1vte, 650hp, 19kts, 21p; 2x1-37/45, (1+1x1)-450TT
	Myg	1	18	Myg	1900		27t, 25.0xxm, 1b,1vc, 285hp, 17.7kts; 1x1-37/45, 1-356TT
	Hvass	2	19, 20	Hvass, Kjæk	1901		74t, 34.1x4.4x1.6m, 2b,2vte, 650hp, 19kts, 16p; 2x1-37/45, (1+1x1)-450TT
	Hauk	2	21, 22	Hauk, Falk	1904		73t, 34.9x4.4x1.6m, 2b,2vte, 750hp, 20kts, 16p; 2x1-37/45, (1+1x1)-450TT
	Ørn	2	23, 24	Ørn , Ravn	1905		73t, 34.5x4.4x1.6m, 2b,1vte, 850hp, 23kts, 16p; 2x1-37/45, (1+1x1)-450TT
	Grib	3	25-27	Grib, Jo, Lom	1906		74t, 36.2x4.5x1.9m, 2b,1vte, 1000hp, 23kts, 16p; 2x1-37/45, (1+1x1)-450TT
Teist	2	28	Teist	1908		103t, 41.1x4.7x2.3m, 2b,1vte, 1700hp, 25kts, 21p; 2x1-47/46, (1+2x1)-450TT	
		29	Skarv	1908			

SUBMARINES

SS	Kobben	1	1	Kobben	1909		206/259t, 39.3x3.7x3.0m, 2d/em, 440/250hp, 11.9/8.9kts, 14p, 30m; 3-450TT
----	--------	---	---	--------	------	---	---

OTHER FIGHTING SHIPS

PG	Sarpen	1	1	Sarpen	1861	No picture	220t; 2x1-65/50, 2x1-37/45
	Vale	2	2	Vale	1874		229t, 27.3x7.9x2.2m, 2b,2vc, 200hp, 8kts, 38p; 1x1-267/14, 1x1-37/20, 2x5-37/17
			3	Uller	1877		
	Sleipner	1	4	Sleipner	1878		720t, 53.3x7.9x3.4m, 2vc, 650hp, 12kts, 90p; 1x1-149/37, 2x1-76/40, 2x1-65/50, 2x5-37/17
	Brage	2	5	Brage	1879		264t, 28.9x7.9x2.2m, 2b,2vc, 220hp, 8.5kts, 38p; 1x1-267/14, 1x1-37/20, 2x5-37/17, 1-356TT(14)
			6	Nor	1879		
	Vidar	1	7	Vidar	1882		262t, 28.9x7.9x2.2m, 2b,2vc, 330hp, 9.5kts, 38p; 1x1-267/17, 1x1-37/20, 2x5-37/17
	Ellida	1	8	Ellida	1882	No picture	1045t, 58.0x9.9x4.4m, 2vc, 900hp, 10.5kts, 130p; 2x1-76/40, 1x1-75/52, 2x1-65/50, 2x1-37/45
	Gor	2	9	Gor	1885		290(17)-278(18)t, 31.3x8.5x2.2m, 2b,2vc, 420hp, 10.5kts, 44p; 1x1-263/17, 1x1-57/40(18), 1x1-37/20(17), 2x5-37/17, 1-356TT
			10	Tyr	1887		
Æger	1	11	Æger	1894		413t, 33.2x8.8x2.4m, 2b,2vte, 350hp, 9kts, 43p; 38deck; 1x1-209/35, 1x1-65/50, 2x1-47/40	



FISHERY PROTECTION VESSELS

FPV	Heimdal	1	1	Heimdal	1892	No picture	640t; 4x1-76/40
	Michael Sars	1	2	Michael Sars	1900	No picture	226t

[home](#)[World navies yesterday](#)[1910](#)

Ottoman Empire 01 January 1910

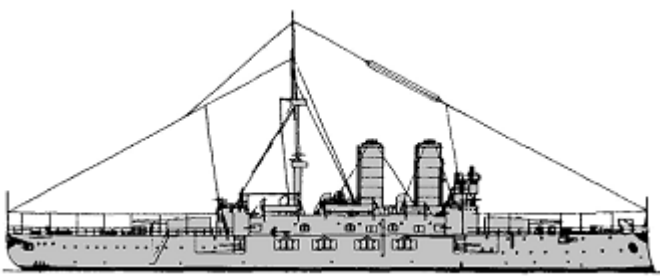
BATTLESHIPS

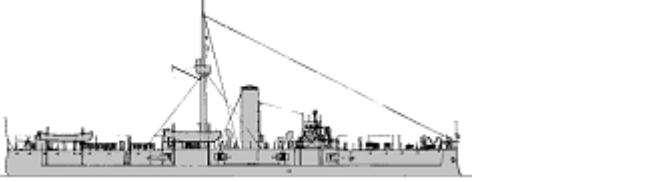
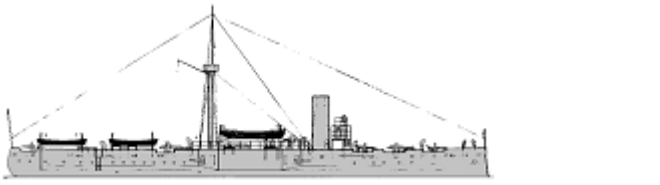
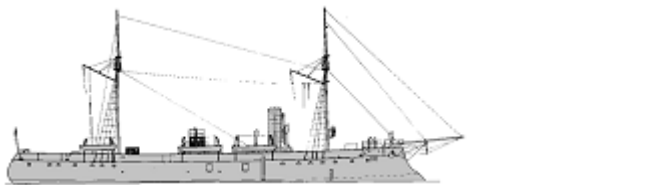

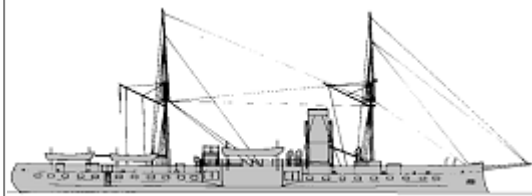
BB	Mesudiye	1	1	Mesudiye	1875		9710t, 102.4x17.9x7.9m, 16b,2vte, 11135hp, 17kts, 700p; iron- 305belt, 229turrets, 203CT; 2x1-234/47, 12x1-152/45, 14x1-76/50, 10x1-57/40, 2x1-47/40
	Asar-i Tevfik	1	1	Asar-i Tevfik	1870		4687t, 83.0ppx16.0x6.5m, 6b,1vte, 4500hp, 15kts, 320p; iron- 203belt, 76deck(steel), 152battery, 152CT(steel); 3x1-149/37, 7x1-120/37, 6x1-57/37, 2x1-37/37
	Avnillah	2		Avnillah	1870		2362t, 71.9x11.0x5.0m, 2b,1hc, 2200hp, 12kts, 145p; iron- 152belt, 127casemates, 152CT(steel); 4x1-149/37, 6x1-75/37, 10x1-57/37, 2x1-47/37
		3		Muin-i Zafer	1870		
BC	Feth-i Bülend	1	4	Feth-i Bülend	1870		2762t, 72.0ppx12.0x5.5m, 2b,1hc, 3250hp, 13kts, 169p; iron- 229belt, 152CT(steel), 229casemates; 4x1-149/37, 6x1-75/37, 6x1-57/37
	İclaliye	1	5	İclaliye	1871		2228t, 66.0x13.0x5.3m, 2b,1hc, 1800hp, 12kts, 148p; iron- 152belt, 114battery; 2x1-229/14, 2x1-178/16, 2x1-87/22, 2x5-37/27, 2x1-25/42
	Mukaddeme-i Hayir	1	6	Mukaddeme-i Hayir	1874		2762t, 72.0ppx12.0x5.5m, 4b,1hc, 3000hp, 12kts, 169p; iron- 229belt, 229casemates; 4x1-229/14, 2x1-87/22, 2x1-57/37, 2x5-37/27, 2x1-25/42



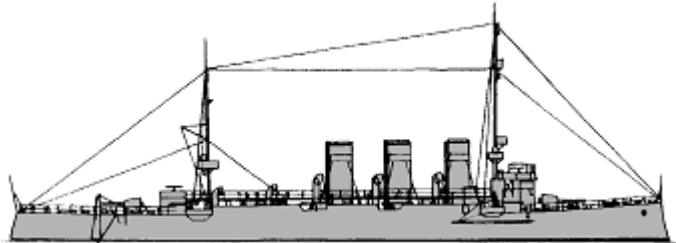
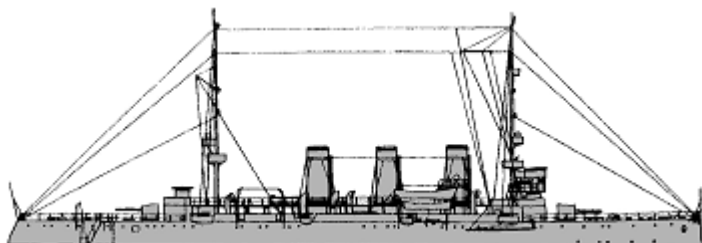
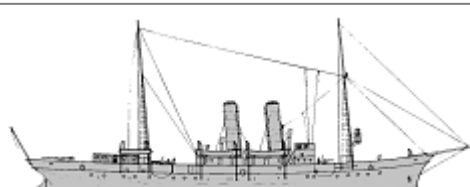

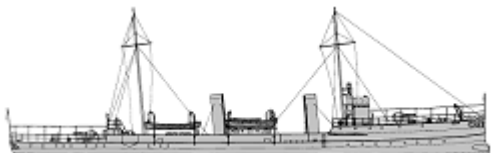

CRUISERS

CL	Mecidiye	1	1	Mecidiye	1903		3967t, 102.4x12.8x4.8m, 16b,2vte, 12500hp, 22kts, 312p; 102slopes, 38deck; 2x1-152/44, 8x1-120/45, 6x1-47/50, 6x1-37/30, 2-450TT
	Hamidiye	1	2	Hamidiye	1904		3904t, 112.0x14.5x4.9m, 6b,2vte, 12000hp, 22kts, 302p; 102slopes, 38deck; 2x1-152/45, 8x1-120/45, 6x1-47/50, 6x1-37/30, 2x1-450TT
CLL	Zuhaf	1	1	Zuhaf	1896		643t, 57.9ppx7.3x3.5m, 2b,1vte, 640hp, 14kts, 82p; 1x1-120/22, 4x1-37/37

TORPEDO SHIPS

PGT	Peleng-i Derya	1	1	Peleng-i Derya	1896		900t, 75.5x8.5x2.9m, 4b,2vte, 4700hp, 18kts, 80p; 2x1-120/37, 2x1-88/27, 5x5-37/27, (1+2x1)-356TT
	Peyk-i Şevket	2	2	Peyk-i Şevket	1907		775t, 80.1ppx8.4x4.6m, 4b,2vte, 5100hp, 21kts, 105p; 2x1-105/37, 6x1-57/42, 2x1-37/42, (1+2x1)-450TT
			3	Berk-i Satvet	1907		
DD	Samsun	4	1	Samsun	1907		284t, 58.2x6.3x2.8m, 2b,2vte, 5950hp, 28kts, 23p; 1x1-65/50, 6x1-47/50, 2x1-450TT
			2	Yarhisar	1907		
			3	Taşoz	1907		
			4	Basra	1907		
	Nasir	2	1, 2	Fatih, Pervin	1889-1890		87t, 39.0x4.8x2.6m, 1b,1vte, 1200hp, 21kts, 27p; 2x5-37/27, 2-356TT

TB							
	Berk Efşan	1	3	Berk Efşan	1894	No picture	230t, 59.9x6.6x2.4m, 2b,2vte, 3500hp, 21kts, 50p; 6x5-37/27, 2-428TT
	Hamidiye	2	4	Hamidiye	1902		145t, 50.6x5.6x1.2m, 3b,2vte, 2400hp, 26kts, 30p; 1x1-37/20, 2x1-450TT
			5	Yunus	1902		
	Akhisar	2	6	Akhisar	1904		165t, 51.0x5.7x1.4m, 2b,2vte, 2400hp, 24kts, 30p; 2x1-37/20, 2x1-450TT
			7	Alpagot	1904		
	Antalya	6	8	Antalya	1906		165t, 51.0x5.7x1.4m, 2b,2vte, 2700hp, 26kts, 30p; 2x1-37/20, 2x1-450TT
			9	Ankara	1906		
			10	Tokad	1906		
			11	Draç	1907		
			12	Kütahya	1907		
			13	Musul	1907		
	Demirhisar	4	14	Demirhisar	1907		101t, 40.2x4.4x1.9m, 2b,1vte, 2200hp, 26kts, 23p; 2x1-37/20, (1+1x2)-450TT
			15	Sultanhisar	1907		
			16	Sivrihisar	1907		
			17	Hamidabad	1907		

OTHER FIGHTING SHIPS

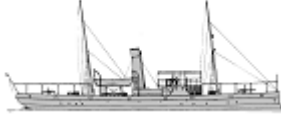
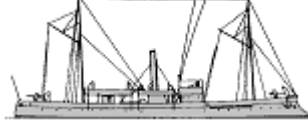
PG	Firat	1	1	Firat	1885	No picture	197t, 37.0ppx6.5x2.4m, 1b,1hc, 280hp, 10kts, 55p; 2x1-37/20, 2x5-37/17
	Nasr-ü Hüda	3	2	Nasr-ü Hüda	1904	No picture	198t, 38.6ppx5.4x1.9m, 1b,1vte, 400hp, 10kts, 45p; 1x1-75/37, 2x1-47/42, 1x1-37/20
			3	Seyyar	1906		
			4	Barika-i Zafer	1908		
	Kastamonu	2	5	Kastamonu	1905		240t, 42.2x5.8x1.8m, 1b,1vte, 460hp, 12kts, 12p; 2x1-47/42
			6	Yozgat	1905		
	Nur-ü Bahir	1	7	Nur-ü Bahir	1898	No picture	450t, 52.0ppx7.8x4.4m, 1b,1vc, 300hp, 12kts; 2x1-75/37
	Marmaris	1	8	Marmaris	1908	No picture	531t, 52.4x7.5x2.4m, 2b,1vte, 950hp, 14.8kts, 66p; 4x1-65/50, 2x1-37/40
	Taşköprü	9	9	Taşköprü	1908		315(12-15)-309(16-20)t, 47.0x6.2x1.9m, 1b,1vte, 480hp, 12kts, 47p; 2x1-47/50
			10	Nevşehir	1908		
			11	Gökçedağ	1908		
			12	Refahiye	1908		
			13	Ayntab	1908		
			14	Malatya	1908		
			15	Seddübahir	1908		
			16	Ordu	1908		
			17	Bafra	1908		
AGS	-	4	1	İskenderun	1895		142t
			2	Sakiz	1895		142t
			3	Nur-ül Bahir	1893		295t

		4	Bahr-i Sefid	1903		210t
--	--	---	--------------	------	--	------

© Ivan Gogin, 2015

[home](#)

[World navies yesterday](#)

[1910](#)

Paraguay 01 January 1910

OTHER FIGHTING SHIPS

APGR	-	1	1	Capitán Cabral	1907		206t; 1x1-76/40
------	---	---	---	----------------	------	--	-----------------

© Ivan Gogin, 2015

[home](#)[World navies yesterday](#)[1910](#)

Persia 01 January 1910

OTHER FIGHTING SHIPS

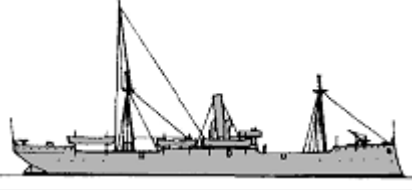
PG	Persepolis	1	1	Persepolis	1885		1200t, 63.1x10.0x5.9m, 1vte, 450hp, 10kts; 1x1-102/27, 1x1-95/19, 2x1-37/40
	Muzaffer	1	2	Muzaffer	1899	No picture	379t, 41.1x7.9x4.0m
PGR	Azerbaijan	1	1	Azerbaijan	1900s	No picture	
	Perebonia	1	2	Perebonia	1900s	No picture	

© Ivan Gogin, 2015

[home](#)[World navies yesterday](#)[1910](#)

Peru 01 January 1910

CRUISERS

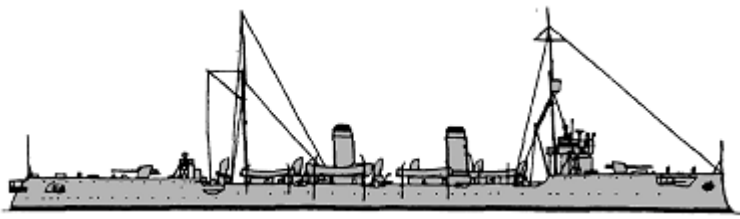
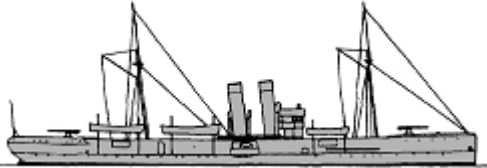
CL	Apurimac	1	1	Apurimac	1850	No picture	1000t; 34guns
	Almirante Grau	2	2	Almirante Grau	1907		4877t, 115.8x12.3x4.3m, 10b,2vte, 14000hp, 24kts, 320p; 38belt, 38deck, 76shields, 76CT; 2x1-152/50, 8x1-76/40, 6x1-57/40, 2x1-37/20, 2-450TT
			3	Coronel Bolognesi	1907		
CLL	Lima	1	1	Lima	1888		1790t, 76.2x10.7x4.6m, 4b,2hc, 1800hp, 16.2kts, 150p; 2x1-152/26, 3x1-47/40

OTHER FIGHTING SHIPS

PG	Santa Rosa	1	1	Santa Rosa	1883	No picture	2x1-152/26
PGR	Iquitos	1	1	Iquitos	1875	No picture	50t, 23.4x3.7x1.2m, 7.5kts; 1x1-47/40
	América	1	2	América	1904	No picture	240t, 40.5x5.9x1.4m, 2b,2vte, 350hp, 14kts, 26p; 4x1-47/40

© Ivan Gogin, 2015

[home](#)[World navies yesterday](#)[1910](#)

Portugal 01 January 1910

BATTLESHIPS

BC	Vasco da Gama	1	1	Vasco da Gama	1876		3200t, 70.9ppx12.2x6.3m, 2vte, 15.5kts, 260p; steel- 250belt, 75deck, 200shields; 2x1-203/40, 1x1-152/45, 1x1-76/40, 6x1-47/40
----	---------------	---	---	---------------	------	--	--

CRUISERS

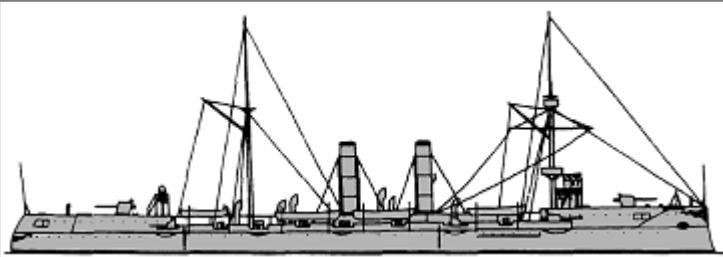
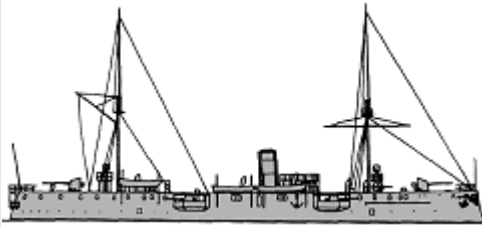
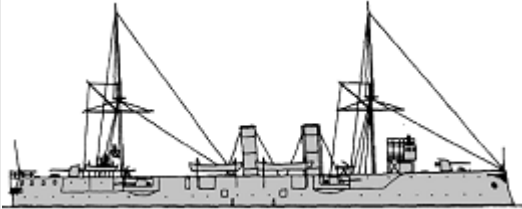
	Dom Carlos I	1	1	Dom Carlos I	1898		4253t, 117.0x14.4x5.3m, 12b,2vte, 12500hp, 22kts, 473p; 110slopes, 37deck, 102CT; 4x1-152/45, 8x1-120/44, 14x1-47/40, 2x1-37/25, 2-356TT
CL	São Gabriel	2	2	São Gabriel	1899		1771t, 75.0x10.8x4.3m, 4b,2vte, 4000hp, 17.5kts, 242p; 20deck, 60CT; 2x1-149/45, 4x1-120/45, 8x1-47/40, 2x1-37/20, 1-356TT
			3	São Rafael	1899		
	Rainha Dona Amélia	1	4	Rainha Dona Amélia	1901		1630t, 75.0ppx11.8x4.5m, 4b,2vte, 5000hp, 20kts, 273p; 30deck; 4x1-149/45, 2x1-100/45, 2x1-47/40, 2x1-37/25, 2-356TT
CLL	Duque da Terceira	1	1	Duque da Terceira	1864	No picture	1406t, 54.9ppx10.4x4.5m, 660hp, 10kts, 194p; 2x1-120/44, 2x1-65/40
	Adamastor	1	2	Adamastor	1897		1757t, 74.0ppx10.7x4.7m, 4b,2vte, 4000hp, 18kts, 237p; 30deck, 65CT; 2x1-149/27, 4x1-105/37, 4x1-65/40, 2x1-37/25, 3-356TT

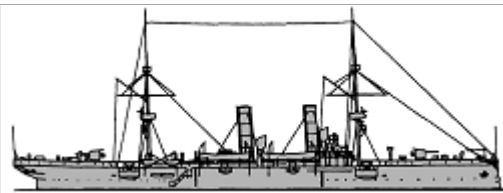

TORPEDO SHIPS

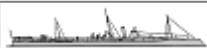
DD	Tejo	1	1	Tejo	1904		522t, 70.0x7.0x2.5m, 4b,2vte, 7000hp, 25kts, 85p; 1x1-100/27, 1x1-65/40, 4x1-47/40, 2x1-356TT
TB	Espadarte	1	1	N°1	1881	No picture	53t, 26.2ppx3.4x1.5m, 1b,1vc, 450hp, 19.7kts, 18p; 2-356TT
	N°2	3	2-4	N°2-4	1886		65t, 36.5ppx3.9x1.0m, 1b,1vc, 700hp, 19kts; 2x5-37/17, 2-356TT

SUBMARINES

SS	Plongeur	1	1	Plongeur	1892	No picture	/100t, 22.0x3.5xm, 2em, /6kts, 6p; 4-356TC
----	----------	---	---	----------	------	------------	--

OTHER FIGHTING SHIPS

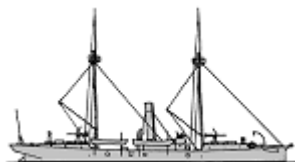
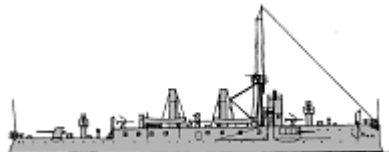
PG	Rio Lima	1	1	Rio Lima	1875	No picture	628t, 45.4x8.6x3.2m, 500hp, 11kts, 109p; 1x1-152/26, 2x1-100/27
	Rio Tâmega	1	2	Rio Sado	1875	No picture	635t, 45.4ppx8.6x3.2m, 500hp, 11kts, 109p; 2x1-105/32, 2x1-65/40, 1x1-37/20
	Tavira	2	3	Tavira	1878	No picture	160t
			4	Faro	1878		
	Vilhena	1	5	Vilhena	1882	No picture	160t, 29.0x4.9x1.8m, 310hp, 12kts, 42p; 1x1-76/16
	Liberal	2	6	Liberal	1884	No picture	560t, 42.5ppx7.9x3.4m, 500hp, 10kts, 109p; 1x1-152/26, 2x1-100/27, 1x1-37/20
			7	Zaire	1884		
	Zambeze	1	8	Zambeze	1886	No picture	631t, 43.6ppx7.9x3.3m, 460hp, 10kts, 113p; 3x1-100/27, 1x1-37/20
	Diu	1	9	Diu	1889	No picture	730t, 45.0ppx8.2x4.0m, 700hp, 11.5kts, 124p; 1x1-149/27, 2x1-105/32
	Limpopo	1	10	Limpopo	1890	No picture	288t, 37.8x6.4x2.0m, 1b,1vc, 520hp, 11.3kts, 42p; 2x1-47/40
	D. Luiz	1	11	D. Luiz	1895	No picture	789t, 45.9ppx8.3x4.2m, 500hp, 10kts, 120p; 4x1-105/32, 2x1-47/40
	Thomaz Andrea	1	12	Al. Baptista de Andrade	1897	No picture	300t, 41.0ppx8.0x2.0m, 500hp, 12kts; 2x1-47/40
	Chaimite	1	13	Chaimite	1898		341t, 41.0ppx8.0x2.0m, 2vte, 480hp, 11kts, 26p; 2x1-47/40
	Pátria	1	14	Pátria	1905		626t, 60.0ppx8.3x2.5m, 4b,2vte, 1800hp, 16.7kts, 95p; 12deck; 4x1-100/45, 6x1-47/40

	Lúrio	2	15	Lúrio	1907		305t, 42.8x7.2x1.8m, 2b,2vte, 500hp, 12.5kts, 51p; 2x1-47/40
			16	Save	1908		
PR	Pedro d'Annaia	1	1	Diogo Cão	1895	No picture	93t, 30.0ppx6.0x0.8m, 500hp, 9kts; 2x1-47/40
	Cacheu	4	2-5	Cacheu, Farim, Tété, Sena	1902-1904	No picture	70t, 9kts; 2x1-37/20
	Infante D. Manuel	1	6	Infante D. Manuel	1904	No picture	38t, 24.6x4.0x0.6m, 1b,1vte(sw), 64hp, 7.5kts, 8p; 2x1-37/20
	Flecha	1	7	Flecha	1909	No picture	44t, 21.0x4.0x0.7m, 1b,1vte(sw), 45hp, 10kts, 7p; 1x1-37/20

© Ivan Gogin, 2014

[home](#)[World navies yesterday](#)[1910](#)

Romania 01 January 1910

CRUISERS

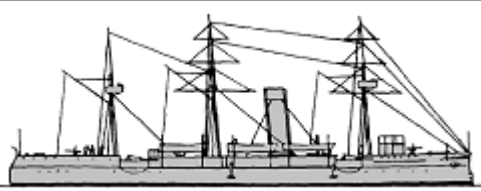
CL	Elisabeta	1	1	Elisabeta	1888		1300t, 73.0x10.2x3.7m, 4b,2vte, 4700hp, 17.3kts, 190p; steel- 86slopes, 43deck; 4x1-120/45, 4x1-75/35, 4-356TT
----	-----------	---	---	-----------	------	--	--

TORPEDO SHIPS

TB	Năluca	3	1-3	Năluca, Sborul, Smeul	1888	No picture	56t, 36.8x3.5x0.9m, 1b,1vc, 540hp, 16kts, 20p; 1x5-37/17(1,2), 2x5-37/17(3), 2-356TT, 1spar torpedo
TBR	Căpitan Nicolae Lascăr Bogdan	8	1-8	Major Ene Constantin, Căpitan Nicolae Lascăr Bogdan, Căpitan Romani Michail, Major Giurascu Dimitrie, Major Sontu Gheorge, Major Grigore Ioan, Locotenent Calinescu Dimitrie, Căpitan Valter Maracineanu	1906-1907		51t, 30.4x4.0x0.8m, 2b,2vce, 550hp, 18kts, 20p; 1x1-47/40, 2spar torpedoes

OTHER FIGHTING SHIPS

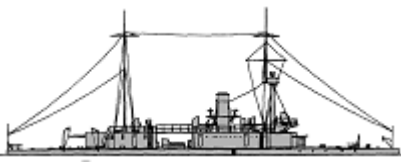
PG	Grivița	1	1	Grivița	1880	No picture	110t, 60.5x5.2x1.8m, 180hp, 9kts, 30p; 2x1-57/42, 2x1-37/42
RMON	Ion C. Brătianu	4	1	Ion C. Brătianu	1907		750t, 63.5x10.5x1.8m, 2b,2vte, 1800hp, 13kts, 110p; 70belt, 70deck, 75turrets, 75CT; 3x1-120/33, 2x1-120/8, 4x1-47/40
			2	Lascăr Catargiu	1907		
			3	Alexandru Lachovari	1908		
			4	Mihail Kogălniceanu	1907		
PGR	Rahova	3	1-3	Rahova, Smardan, Opanezul	1882	No picture	45t, 8.5kts; 1x1-37/20
	Oltul	3	4	Oltul	1888	No picture	116t, 30.5x4.1x1.7m, 380hp, 13kts, 30p; 1x1-57/42, 1x1-37/42
			5	Siretul	1888		
			6	Bistrița	1888		
	Alexandru cel Bun	1	7	Alexandru cel Bun	1882	No picture	104t
Monteano	3	8-10	Monteano, Olteano, Imeo	1893	No picture	95t, 13.5kts; 1x1-57/42, 2x1-37/42	

[home](#)[World navies yesterday](#)[1910](#)

Russia 01 January 1910

BATTLESHIPS

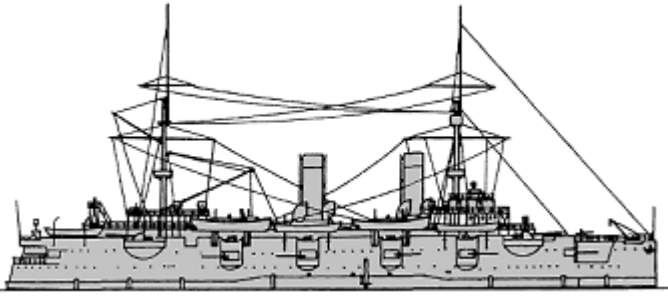
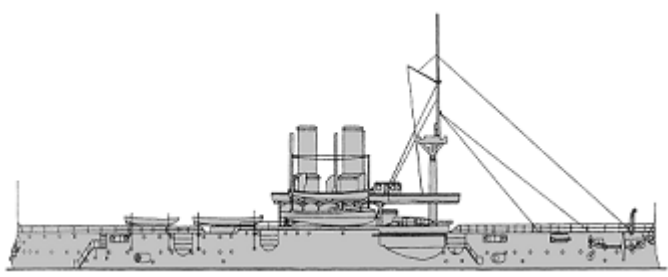
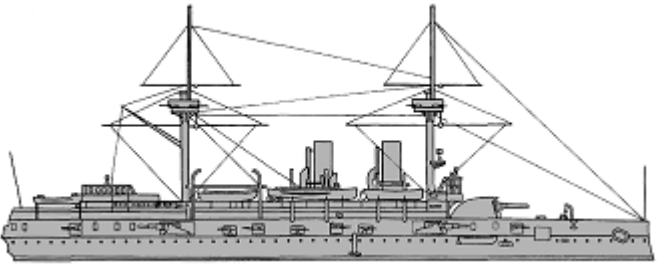
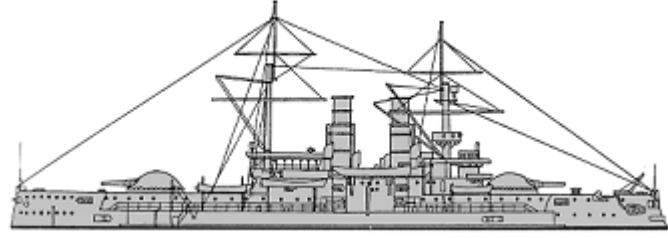
Pyotr Velikiy	1	1	Pyotr Velikiy	1876		9790t, 103.5x19.0x8.3m, 12b,2vc, 5500hp, 12.9kts, 440p; iron- 356belt, 76deck; 4x1-203/49, 12x1-152/44, 12x1-75/48, 4x1-57/40, 8x1-47/40, 2x1-37/20
Yekaterina II	2	2	Sinop	1889		10181(2)-10750(3)t, 103.5x21.0x8.8m, 16b,2vte, 13000hp, 16(2)-16.5(3)kts, 633-645p; compound(2)-steel(3), 406belt, 57deck, 305redoubt, 292(2)-305(3)CT; 3x2-305/27(2), 3x2-305/32(3), 7x1-152/32, 2x1-63/17(2), 8x1-47/40(3), 8x5-47/22(2), 4x5-37/17(2), 7-381TT(2), 100mines(2)
		3	Georgiy Pobedonosets	1893		
Imperator Aleksandr II	1	4	Imperator Aleksandr II	1890		10010t, 105.6x20.4x7.8m, 12b,2vc, 8500hp, 15.3kts, 616p; compound- 356belt, 63deck, 254barbette, 254CT; 1x2-305/27, 5x1-203/43, 8x1-152/44, 4x1-63/17, 10x1-47/40
Dvenadtsat Apostolov	1	5	Dvenadtsat Apostolov	1892		8709t, 104.2x18.3x8.4m, 8b,2vte, 8750hp, 15.7kts, 599p; compound- 356belt, 63deck, 305barbette, 203CT; 2x2-305/27, 4x1-152/32, 12x1-47/40, 10x1-37/20, 4x5-37/17, 6-381TT

BB

Tri Svyatitelya

1 6

Tri Svyatitelya

1897

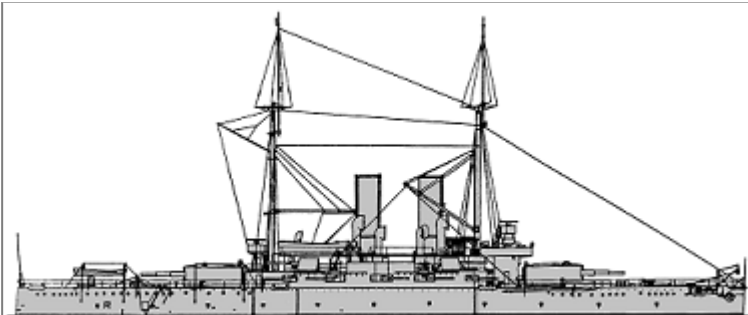

13318t, 115.1x22.3x8.7m, 14b,2vte, 11300hp, 753p; Harvey+NS- 457belt, 76deck, 406turrets, 305CT; 2x2-305/38, 14x1-152/44, 4x1-120/43, 2x1-63/17, 10x1-47/40, 10x1-37/20, 6-381TT

Rostislav

1 7

Rostislav

1898

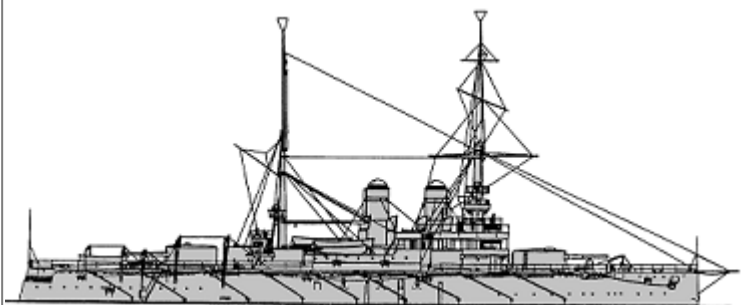

10140t, 107.2x20.7x6.7m, 12b,2vte, 8700hp, 15.6kts, 632p; Harvey- 356belt, 76deck, 254turrets, 152CT; 2x2-254/43, 4x2-152/44, 2x1-63/17, 12x1-47/40, 14x1-37/20, 6-381TT

Tsesarevich

1 8

Tsesarevich

1903

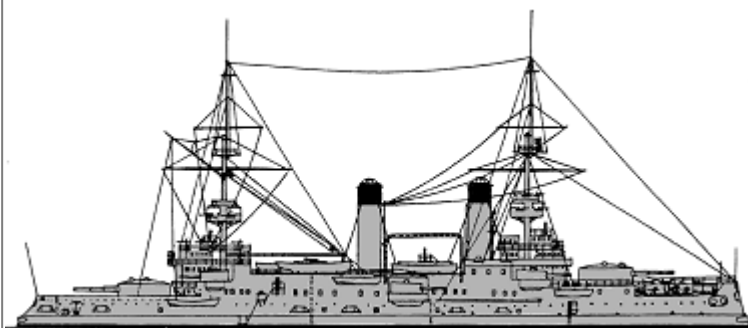

13110t, 118.5x23.2x7.9m, 20b,2vte, 16300hp, 18kts, 779p; 250belt, 90deck, 250turrets, 254CT; 2x2-305/38, 6x2-152/44, 20x1-75/48, 4x1-47/40, 4-381TT

Borodino

1 9

Slava

1905

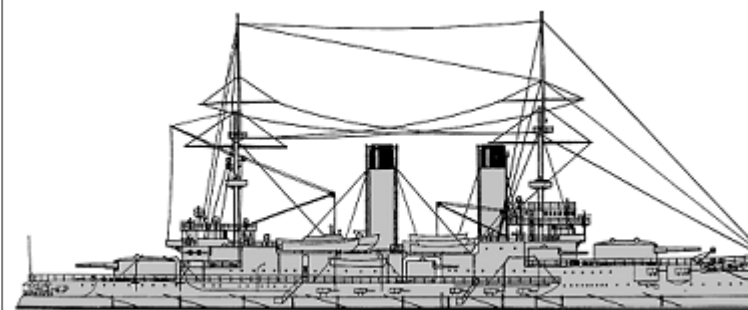

14415t, 121.0x23.2x8.0m, 20b,2vte, 16300hp, 17.5-17.8kts, 835p; 194belt, 63deck, 254turrets, 203CT; 2x2-305/38, 6x2-152/44, 20x1-75/48, 4x1-47/40, 4-381TT

Knyaz
Potyomkin-
Tavricheskiy

1 10

Knyaz
Potyomkin-
Tavricheskiy

1905

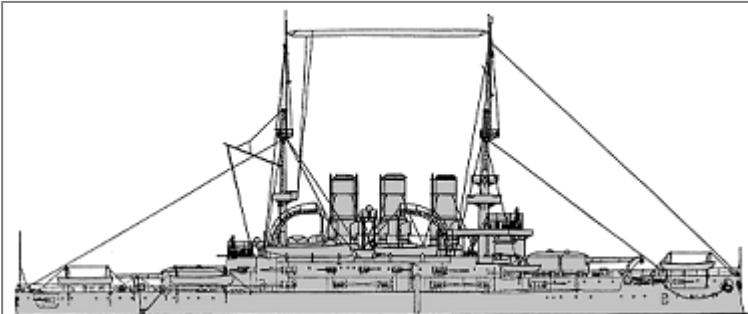

12582t, 115.4x22.3x8.2m, 22b,2vte, 10600hp, 16.6kts, 750p; 229belt, 76deck, 254turrets, 229CT; 2x2-305/38, 16x1-152/44, 16x1-75/48, 2x1-63/17, 6x1-47/40, 2x1-37/20, 5-381TT



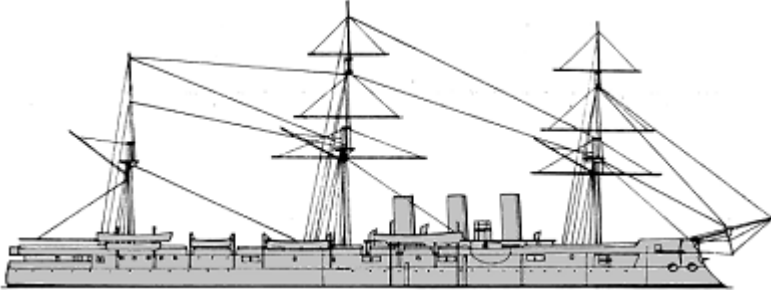
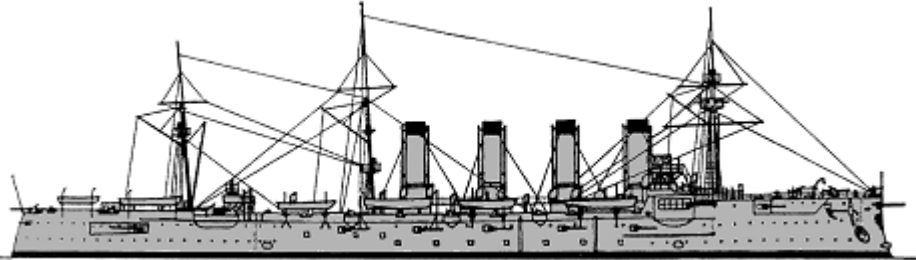
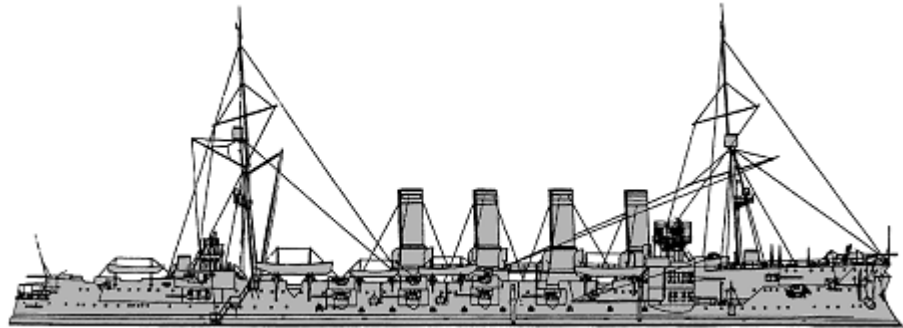
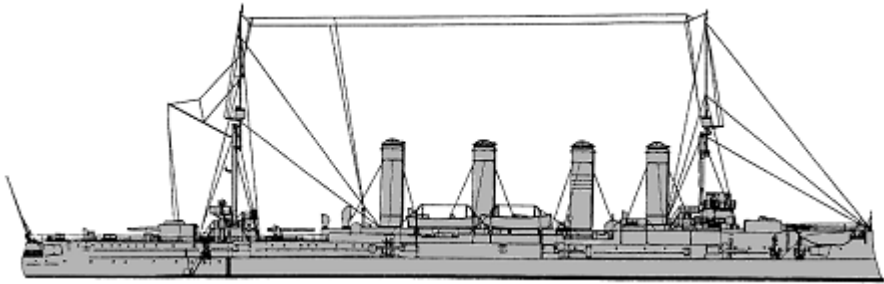
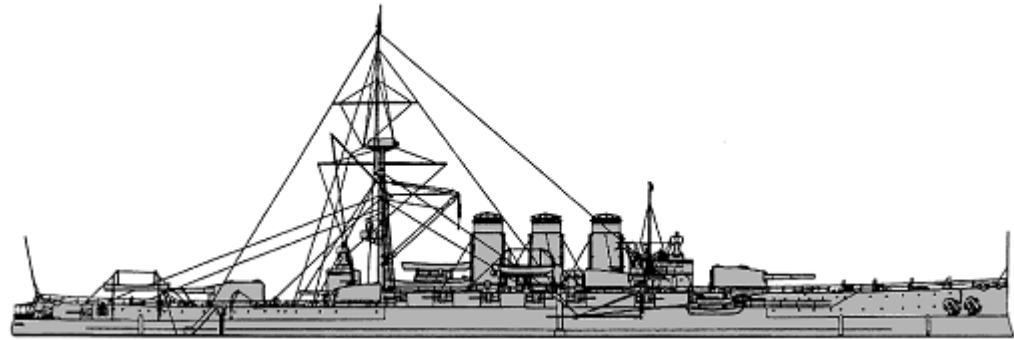

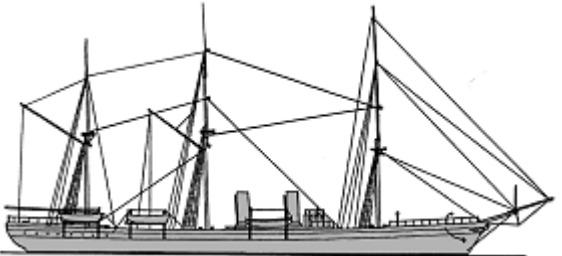
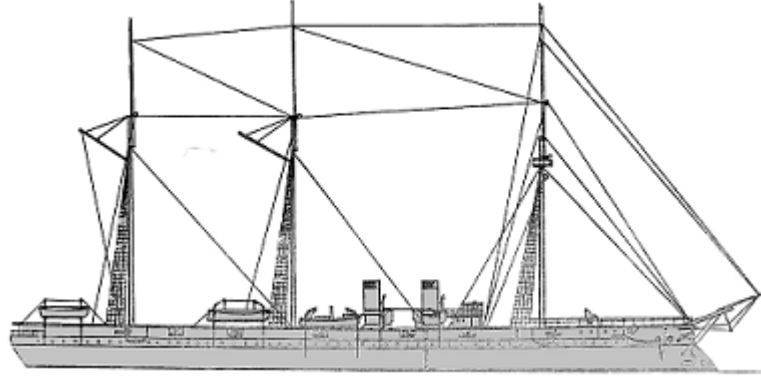
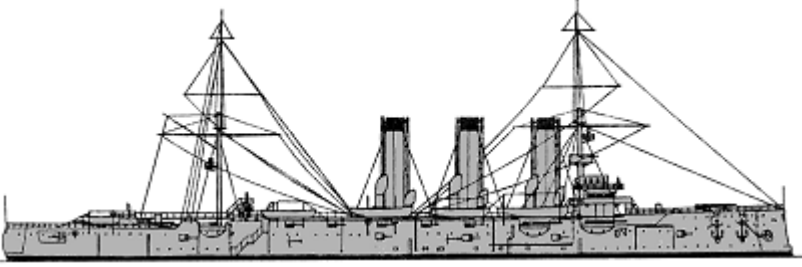
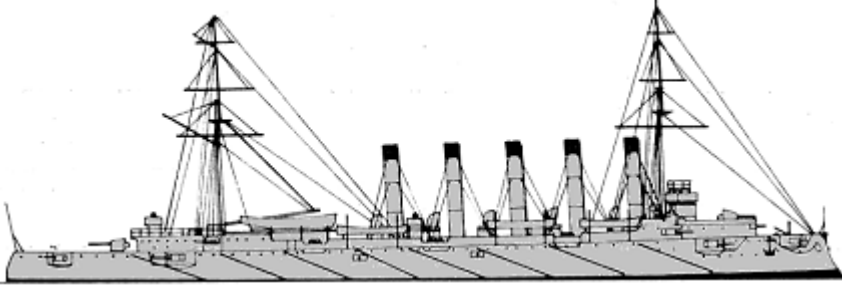
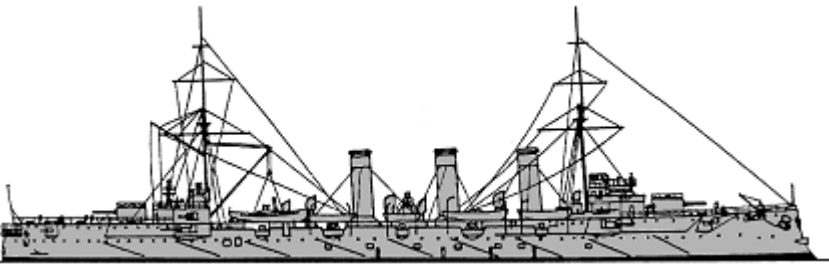
CRUISERS

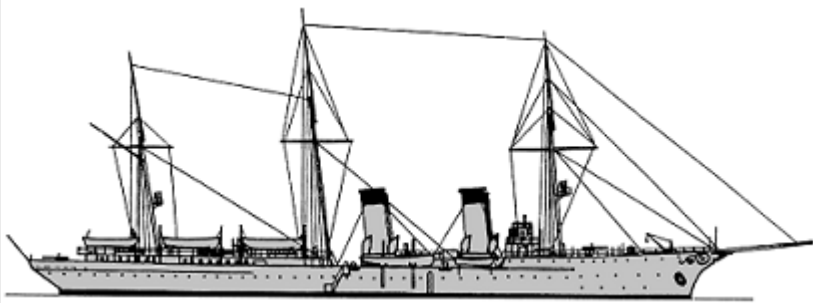
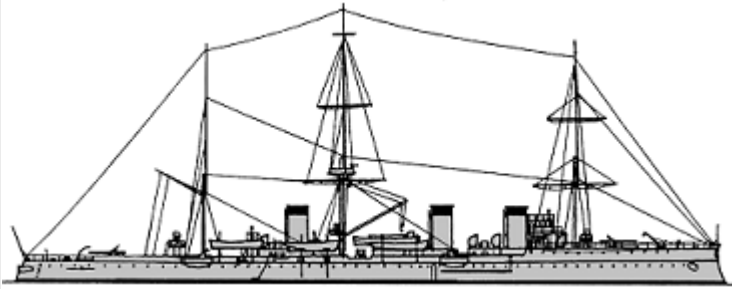
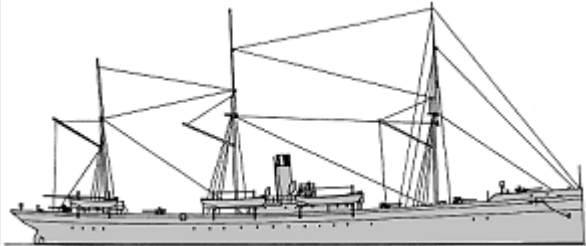

CA	Pamyat Azova	1	1	Dvina	1890		6674t, 117.2x17.2x8.2m, 18b,2vte, 8500hp, 17kts, 640p; compound- 152belt, 63deck, 51shields, 38CT; 4x1-47/40
	Rossiia	1	2	Rossiia	1897		12195t, 147.8x20.9x7.9m, 32b,2vte, 14500hp, 20.4kts, 839p; Harvey- 203belt, 76deck, 127casemates, 305CT; 4x1-203/43, 22x1-152/44, 15x1-75/48, 300mines
	Gromoboy	1	3	Gromoboy	1899		12455t, 146.6x20.9x7.9m, 32b,3vte, 14500hp, 19kts, 874p; 152belt, 76deck, 127casemates, 305CT; 4x1-203/43, 22x1-152/44, 18x1-75/48, 12x1-47/40, 18x1-37/20, 4-381TT
	Bayan	1	4	Admiral Makarov	1908		8250t, 138.8x17.5x6.6m, 26b,2vte, 16500hp, 21kts, 573p; 175belt, 30deck, 132turrets, 136CT; 2x1-203/43, 8x1-152/44, 22x1-75/48, 2-450TT
	Ryurik	1	5	Ryurik	1909		17880t, 161.2x22.9x8.7m, 28b,2vte, 19700hp, 21kts, 950p; 152belt, 76deck, 203turrets, 203CT; 2x2-254/49, 4x2-203/49, 20x1-120/49, 4x1-47/40, 2-450TT
	Vityaz	1	1	Rynda	1886		3537t, 79.4x13.7x5.3m, 10b,1hc, 3000hp, 11.5kts, 396p; steel- 38deck; 4x1-

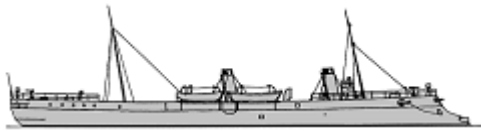

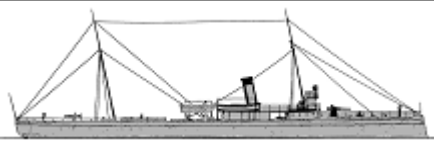

CL					75/48, 4x1-47/40	
	Admiral Kornilov	1 2	Admiral Kornilov	1888		5880t, 112.2x14.8x7.8m, 8b,2hte, 5977hp, 17.6kts, 479p; steel- 63deck, 76CT; 10x1-152/44, 4x1-75/48, 6x1-47/40, 2x5-37/17, 6-381TT
	Pallada	3	Diana	1901		6932(3)-6897(4)t, 126.8x16.8x6.5m, 24b,3vte, 11610hp, 19.2kts, 570p; NS-63slopes, 38deck, 25(4)shields, 152CT; 8x1-152/44(3), 10x1-152/44(4), 24x1-75/48(3), 20x1-75/48(4), 8x1-37/20(3), 3-381TT(3), 126mines(4)
		2 4	Avrora	1903		
	Askold	1 5	Askold	1901		5950t, 132.1x15.6x6.2m, 19b,3vte, 19000hp, 23kts, 534p; 76slopes, 51deck, 25shields, 152CT; 12x1-152/44, 12x1-75/48, 2x1-63/17, 8x1-47/40, 2x1-37/20, 5-381TT
	Bogatyry	4	6	Bogatyry	1902	
7			Oleg	1904		
8			Pamyat Merkuriya	1905		
9			Kagul	1909		
Almaz	1 1	Almaz	1903		3285t, 111.5x13.3x5.3m, 16b,2vte, 7500hp, 19kts, 295p; 6x1-75/48, 6x1-47/40	

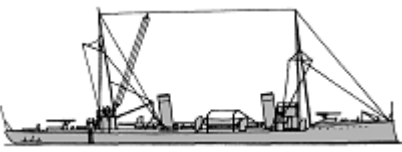







CLL						
	Zhemchug	1	2	Zhemchug	1904	
AMC -		1	Aziya	1874		2449t, 82.0x10.7xm, 1100hp, 15.6kts; 2x1-152/23, 7x1-107/17
		2	Afrika	1878		2590t, 90.2x10.9xm, 1417hp, 12.8kts; 5x1-152/23, 4x1-107/17, 2x1-87/21

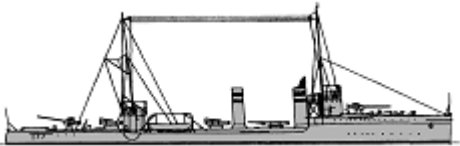

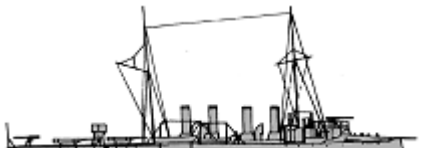
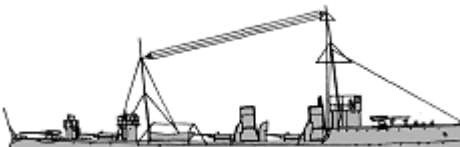

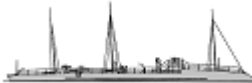
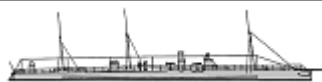





TORPEDO SHIPS



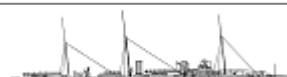

	Leytenant Ilyin	1	1	Leytenant Ilyin	1887		714t, 72.3x7.4x3.2m, 6b,2vte, 3500hp, 20.8kts, 128p; steel- 19deck; 5x1-47/40, 10x1-37/20, 5-381TT
PGT	Kazarskiy	4	2	Kazarskiy	1890		432t, 60.2x7.4x3.5m, 2b,1vte, 3500hp, 21-22.5kts, 65p; 3x1-75/48(2), 2x1-57/50(3,4), 4x1-47/40(3,4), 6x1-47/40(5), 3x1-37/20(3-5), (1+1x1)-381TT(3-5)
			3	Voevoda	1892		
			4	Posadnik	1892		
			5	Griden	1895		
	Abrek	1	6	Abrek	1897		675t, 65.5x7.8x3.4m, 4b,2vte, 4500hp, 21.2kts, 88p; 4x1-57/50, 2x1-47/40
	Sokol	1	1	Prytkiy	1895		240t, 57.9x5.6x2.3m, 8b,2vte, 3800hp, 29kts, 54p; 1x1-75/48, 3x1-47/40, 2x1-381TT
			2	Poslushny	1900		
			3	Pylkiy	1900		
			4	Prochny	1902		

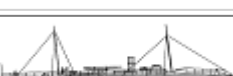
Krechet	18	5	Porazhayushchiy	1902		305t, 57.9-61.0x5.6-5.7x2.3-2.4m, 8b,2vte(2-6,11)-4b,2vte(7-10,12-18), 3800hp, 26.5-27.5kts, 51-58p; 1x1-75/48(2-4,6-11,16-19), 2x1-75/48(5,12-15), 3x1-47/40(2-4,6-11,16-19), 2x1-381TT(2-4,6-11,16-19), 2x1-450TT(5,12-15), 10mines(5,12-15)				
		6	Pronzitelny	1902						
		7	Prozorlivy	1902						
		8	Rezvy	1902						
		9	Retivy	1902						
		10	Ryany	1902						
		11	Podvizhny	1902						
		12	Strogiy	1902						
		13	Smetlivy	1902						
		14	Svirepy	1902						
		15	Stremitelny	1902						
		16	Serdity	1903						
		17	Smely	1903						
		18	Skory	1903						
		19	Statny	1904						
		Kit	3	20			Besposhchadny	1900		445t, 63.5x7.0x2.7-2.9m, 4b,2vte, 6000hp, 27kts, 64p; 1x1-75/48, 5x1-47/40, 3x1-381TT
				21			Besshumny	1900		
				22			Besstrashny	1900		
		Forel	2	23			Vlastny	1902		347t, 56.6x5.9x3.0m, 4b,2vte, 5200hp, 26.5kts, 64p; 1x1-75/48, 5x1-47/40, 2x1-381TT
24	Grozovoy			1902						
Boykiy	15	25	Boykiy	1902		520-530t, 64.0x6.4x2.4-2.5m, 4b,2vte, 5700hp, 26kts, 69p; 2x1-75/48(25-28,39), 1x1-75/48(29-38), 5x1-47/40(29-38), 2x1-450TT(25-28,39), (1+2x1)-381TT(29-38), 18mines				
		26	Bravy	1902						
		27	Bodry	1902						
		28	Vidny	1905						
		29	Zharkiy	1905						
		30	Zhivoy	1906						
		31	Zhivuchiy	1906						
		32	Zhutkiy	1905						
		33	Zavetny	1903						
		34	Zavidny	1903						
		35	Zorkiy	1905						
		36	Zvonkiy	1905						
		37	Leytenant Pushchin	1907						
		38	Grozny	1904						
		39	Gromyashchiy	1905						
		40	Leytenant Burakov	1905						
		41	Metkiy	1906						



DD	Leytenant Burakov	11	42	Ispolnitelny	1906		492t, 56.5x6.4x3.5m, 4b,2vte, 5700hp, 27kts, 67p; 2x1-75/48, 2x1-450TT
			43	Iskusny	1906		
			44	Krepkiy	1906		
			45	Molodetskiy	1906		
			46	Lyogkiy	1906		
			47	Moshchny	1905		
			48	Lovkiy	1906		
			49	Letuchiy	1906		
			50	Likhoy	1906		
			DD	Ukrayna	8		
52	Voyskovoy	1905					
53	Turkmenets-Stavropolskiy	1905					
54	Kazanets	1906					
55	Steregushchiy	1906					
56	Strashny	1906					
57	Donskoy Kazak	1906					
58	Zabaykalets	1907					
DD	Emir Bukharskiy	4	59	Emir Bukharskiy	1905		720t, 71.9x7.2x2.7m, 4b,2vte, 6500hp, 25kts, 99p; 2x1-75/48, 6x1-57/50, 3x1-450TT, 20mines
			60	Finn	1906		
			61	Moskvityanin	1906		
			62	Dobrovolets	1906		
DD	Tochny	5	63	Tochny	1906		370-385t, 58.4x5.6x2.2m, 4b,2vte, 3800hp, 26kts, 60p; 1x1-75/48, 3x1-47/40, (1+1x1)-381TT
			64	Trevozhny	1907		
			65	Tvyordy	1907		
			66	Inzhener-Mekhanik Anastasov	1908		
			67	Leytenant Maleev	1908		
DD	Inzhener-Mekhanik Zverev	10	68	Inzhener-Mekhanik Zverev	1906		540t, 63.6x7.0x2.7m, 4b,2vte, 6000hp, 27kts, 65p; 2x1-75/48, 3x1-450TT, 16mines
			69	Inzhener-Mekhanik Dmitriev	1906		
			70	Boevoy	1906		
			71	Burny	1906		
			72	Vnimatelny	1906		
			73	Bditelny	1906		
			74	Vnushitelny	1906		
			75	Vynoslivy	1906		
76	Kapitan Yurasovskiy	1907					



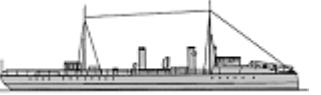

		77	Leytenant Sergeev	1907		
Vsadnik	4	78	Vsadnik	1906		930t, 71.9x7.2x2.4m, 4b,2vte, 6500hp, 25kts, 99p; 2x1-75/48, 6x1-57/50, 3x1-450TT, 25mines
		79	Gaydamak	1906		
		80	Amurets	1907		
		81	Ussuriets	1907		
General Kondratenko	4	82	General Kondratenko	1906		840t, 75.2x8.2x2.4m, 4b,2vte, 7300hp, 25.5kts, 102p; 2x1-75/48, 6x1-57/50, 3x1-450TT, 25mines
		83	Okhotnik	1906		
		84	Sibirskiy Strelak	1906		
		85	Pogranichnik	1906		
Silny	8	86	Silny	1907		475t, 64.0x6.4x2.6m, 4b,2vte, 5800hp, 27kts, 67p; 2x1-75/48, 2x1-450TT
		87	Storozhevoy	1907		
		88	Stroyny	1907		
		89	Razyashchiy	1908		
		90	Rastoropny	1908		
		91	Delny	1907		
		92	Deyatelny	1907		
Leytenant Shestakov	4	94	Leytenant Shestakov	1909		849t, 74.1x8.3x2.6m, 4b,2vte, 6500hp, 25kts, 91p; 1x1-120/43(94-96), 6x1-75/48(97), 5x1-75/48(95,96), 5x1-47/40(94), 3x1-450TT
		95	Kapitan Saken	1909		
		96	Kapitan-Leytenant Baranov	1909		
		97	Leytenant Zatsaryonny	1909		
Poti	1	1	No258	1883		63t, 38.0x3.1x2.0m, 1b,1vc, 575hp, 18.5kts, 18p; 2x1-37/20
No17	2	2, 3	No106, 107	1888		74t, 38.9x3.5x2.3m, 1b,1vc, 296hp, 15.8kts, 21p; 4x5-37/17, 2-381TT
Sveaborg	2	4	No205	1886		96(4)-108(5)t, 46.8x3.4(4)-3.7(5)x2.6(4)-2.5(5)m, 1b,1vte, 737(4)-837(5)hp, 19.2(4)-19.7(5)kts, 21p; 2x5-37/17, 2-381TT
		5	No206	1886		
Vyborg	1	6	No102	1886		150t, 45.1x5.2x2.1m, 2b,2vc, 1300hp, 20kts, 24p; 2x5-37/17, 2-381TT
Abo	1	7	No108	1886		76t, 38.5x4.5x1.9m, 1b,1vc, 640hp, 19.3-20kts, 21p; 2x1-47/40, 2x5-37/17
Yalta	6	8-13	No261-266	1886		85-90t, 38.6x4.6x2.0m, 1b,1vte, 900hp, 20-20.8kts, 18p; 2x5-37/17, 2-381TT
Yanchikhe	2	14, 15	No201, 202	1889		76t, 39.0x4.5x1.9m, 1b,1vc, 970hp, 16.8-17.2kts, 21p; 2x5-37/17, 2-381TT

TB	Adler	1	16	No259	1890		164t, 46.9x5.1x2.0m, 2b,2vte, 2000hp, 26.7kts, 25p; 2x5-37/17, (1+2x1)-381TT
	Anakriya	1	17	No260	1890		100t, 38.6x4.8x2.1m, 2b,1vte, 1100hp, 21kts, 21p; 2x5-37/17, (1+1x1)-381TT
	Biorke	4	18-21	No111-114	1891-1892		81t, 38.4x4.5x2.6m, 1b,1vte, 1000-1100hp, 17.8-19kts, 21p; 2x5-37/17, 2x1-381TT
	Borgo	1	22	No117	1891		118t, 41.7x4.5x2.6m, 1b,1vte, 1245hp, 20kts, 21p; 2x5-37/17, (1+1x1)-381TT
	Anapa	2	23, 24	No252, 253	1891-1892		96t, 38.4x4.5x2.6m, 1b,1vte, 1000-1100hp, 17.2-19kts, 18p; 2x5-37/17, 2x1-381TT
	Dago	2	25	No118	1892		101-105t, 46.5-46.8x3.9x2.3-2.6m, 1b,1vte, 1000-1030hp, 16.2-19kts, 21p; 2x5-47/22(25), 2x5-37/17(26), (1+1x1)-381TT(25), 1x1-450TT(26)
			26	No256	1892		
	Pernov	1	27	No103	1892		120t, 42.0x4.5x2.1m, 2b,2vte, 2000hp, 26kts, 21p; 2x5-37/17
	Tosna	1	28	No115	1893		85-87t, 38.7x4.6x2.0m, 1b,1vte, 1000hp, 20kts, 21p; 2x5-47/22, (1+1x1)-381TT
	Aspe	4	29	No121	1895		105t, 38.8x4.8x2.1m, 2b,1vte, 1300hp, 20kts, 21p; 2x5-37/17, (1+1x1)-381TT
			30	No122	1895		
			31	No125	1894		
			32	No126	1894		
	Sestroretsk	1	33	No104	1894		80t, 36.8x4.2x2.6m, 1b,1vte, 1300hp, 23kts, 21p; 2x5-37/17, (1+1x1)-381TT
	No119	20	34	No119	1895		120t, 42.0x4.5x2.1m, 2b,2vte, 2000hp, 19.5-23.2kts, 21p; 2x5-37/17, (1+2x1)-381TT
35			No120	1895			
36			No127	1898			
37			No128	1898			
38			No129	1899			
39			No130	1900			
40			No133	1897			
41			No134	1897			
42			No135	1897			
43			No136	1897			
44			No137	1897			
45			No138	1897			
46			No139	1897			
47	No140	1897					
48	No141	1897					
49	No142	1897					
50	No270	1897					

		51	No271	1897		
		52	No272	1899		
		53	No273	1899		
No131	3	54	No131	1897		100t, 38.7x5.2x2.0m, 2b,2vte, 1000hp, 21kts, 18p; 2x5-37/17, (1+1x1)-381TT
		55	No132	1896		
		56	No268	1895		
No208	3	57	No209	1899		130t, 42.0x4.5x2.1m, 2b,2vte, 1460hp, 18.5kts, 21p; 2x5-37/17, (1+2x1)-381TT
		58	No210	1899		
		59	No211	1900		
No212	2	60	No212	1902		204t, 53.5x5.3x1.6m, 4b,2vte, 3800hp, 24kts, 26p; 3x1-37/20, (1+2x1)-381TT
		61	No213	1902		
No214	8	62	No214	1903		152t, 45.1x4.7x2.7m, 2b,2vte, 3700hp, 29kts, 28p; 2x1-47/40, 1x2-381TT
		63	No215	1903		
		64	No216	1903		
		65	No217	1903		
		66	No218	1903		
		67	No219	1903		
		68	No220	1903		
		69	No222	1902		
Lastochka	1	70	Lastochka	1905		140t, 46.5x4.7x1.5m, 2b,2st+1vte, 2250hp, 26.4kts, 23p; 2x1-47/40, 3x1-381TT

SUBMARINES

SS	Delfin	1	1	Delfin	1904		113/136t, 19.6x3.6x3.0m, 1pe/em, 300/120hp, 9/7kts, 12p, 26m; 2-381TC
	Som	2	Som	1904		105/120(2)-105/124(3-8)t, 19.3(2)-19.8(3-8)x3.6x2.9m, 1pe/em(2-7)-1d/em(8), 160/70hp, 8.5/6kts, 18p, 30m; 1-450TT	
		3	Shchuka	1905			
		4	Peskar	1906			
		5	Sterlyad	1906			
		6	Beluga	1906			
		7	Losos	1906			
	8	Sudak	1907				
	Osyotr	9	Osyotr	1905		136/174(9)-153/189(10-14)t, 19.8(9)-22.0(10-14)x3.4(9)-3.6(10-14)x3.7m, 2pe/em, 240/120(9)-240/130(10-14)hp, 8.5/5.6(9)-8.3/5(10-14)kts, 12p, 30m; 3-450TT	
		10	Kefal	1905			
		11	Paltus	1906			
		12	Bychok	1906			
		13	Plotva	1906			
		14	Sig	1905			
		15	Kasatka	1905			

Kasatka	6	16	Makrel	1908		142/177t, 33.4x3.4x2.8m, 1peg,1em(15,17-20)-2pe,1em(16), 100(15,17-20)-120/100(16)hp, 14/8.5(15,17-20)-9/8.5(16)kts, 24p, 50m; 4-450TT	
		17	Nalim	1905			
		18	Okun	1908			
		19	Skat	1905			
		20	Feldmarshal Graf Sheremetyev	1905			
		Karp	2	21			Karp
22	Karas			1907			
Pochtovy	1	23	Pochtovy	1908		134/149t, 36.0x3.2x2.7m, 2pe/1pe, 260/130hp, 11.6/6.2kts, 11p, 30m; 4-450TT	
Minoga	1	24	Minoga	1909		123/152t, 32.6x2.8x2.7m, 1d/em, 240/70hp, 10/5.2kts, 22p, 45m; 2-450TT	
Kayman	3	25	Alligator	1909		409/482t, 40.8x3.9x4.9m, 2pe/em, 1200/200hp, 10.7/8.8kts, 34p, 50m; 4-450TT	
		26	Kayman	1909			
		27	Krokodil	1909			
SSX	Forel	1	1	Forel	1904		17/18t, 12.5x1.7x1.1m, 1em, 65hp, 4.5/3.5kts, 4p, 10m; 2-381TT

ESCORTS

PC	Dozorny	2	1	Dozorny	1905		100t, 30.8x5.0x1.7m, 2b,1vte, 660hp, 16kts, 31p; 1x1-37/20
			2	Razvedchik	1905		

OTHER FIGHTING SHIPS

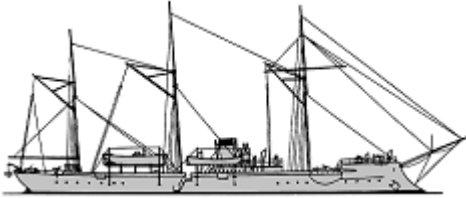
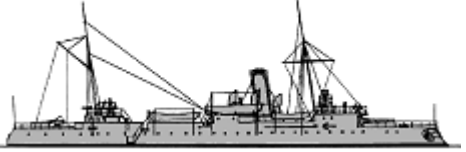
Koreets	1	1	Mandzhur	1887		1418t, 66.6x10.7x3.8m, 6b,2hc, 1500hp, 13kts, 179p; 2x1-203/33, 1x1-152/32, 4x1-107/17, 1x1-63/17, 2x1-47/40, 4x5-37/17, 1-381TT			
			Kubanets	6			2	Kubanets	1887
							3	Terets	1887
							4	Uralets	1888
							5	Zaporozhets	1888
							6	Chernomorets	1889
							7	Donets	1889
Grozyashchiy	1	8	Grozyashchiy	1892		1627t, 72.3x12.7x4.0m, 6b,2vte, 2050hp, 14-14.5kts, 178-188p; steel- 127belt, 38deck, 25CT; 1x1-229/32, 1x1-152/32, 6x1-47/40, 4x5-37/17, 2-381TT, 20mines			
			PG						

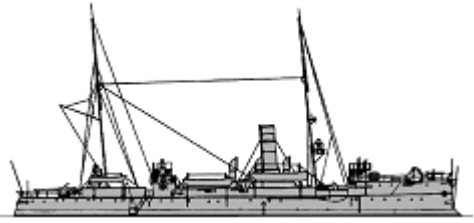
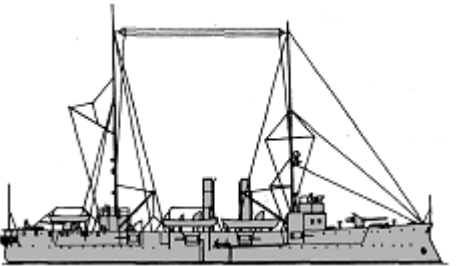
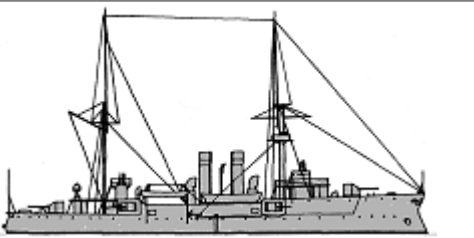
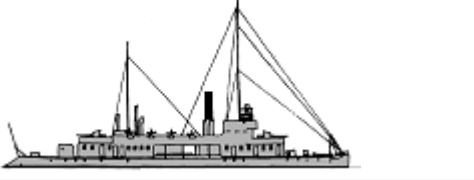
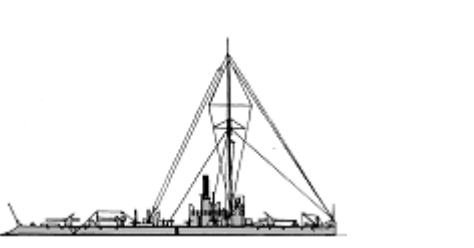

	Khrabry	1	9	Khrabry	1897		20mines
	Khivinets	1	10	Khivinets	1906		1360t, 70.5x11.3x3.5m, 8b,2vte, 1400hp, 13.5kts, 161p; steel- 45CT; 2x1-120/43, 8x1-75/48
	Gilyak	4	11	Gilyak	1907		1100t, 66.5x11.0x3.4m, 4b,2vte, 900hp, 12kts, 140p; 20CT; 2x1-120/43, 4x1-75/48, 40mines
12			Koreets	1907			
13			Bobr	1908			
14			Sivuch	1908			
PGR	Buryat	3	1	Buryat	1907		288t, 54.5x8.2x0.9m, 2b,2vte, 480hp, 11.5kts, 40p; 12belt, 5deck, 8CT; 2x1-75/48
			2	Mongol	1907		
			3	Orochanin	1907		
	Vogul	7	4	Vogul	1909		349t, 54.5x8.2x1.2m, 2b,2vte, 480hp, 10.5kts, 63p; 13belt, 9deck, 13CT; 2x1-120/43, 1x1-122/12
			5	Votyak	1909		
			6	Zyryanin	1909		
			7	Kalmyk	1909		
			8	Kirgiz	1909		
			9	Korel	1909		
			10	Sibiryak	1909		

COASTAL FORCES

PT	No1	10	1-10	No1-10	1906		35t, 27.4x3.7x1.5m, 2pe, 600hp, 20kts, 11p; 1x1-47/40, 1x1-450TT
----	-----	----	------	--------	------	---	--

MINE WARFARE SHIPS

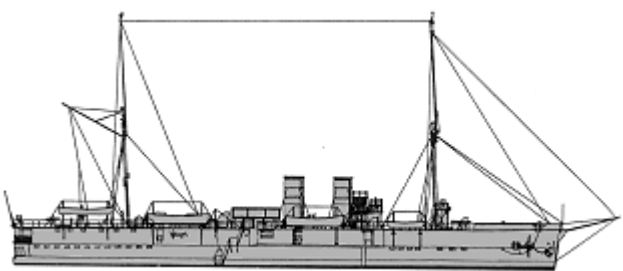
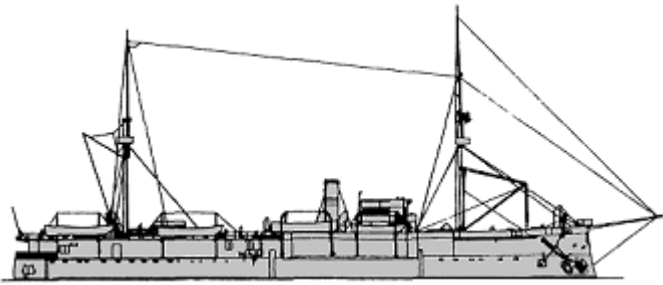
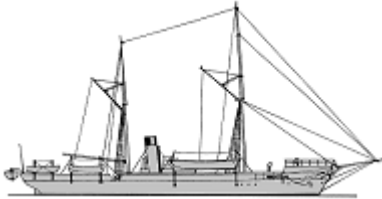
		1	Narova	1875		
General-Admiral	2	2	Onega	1877		5031(1)-4838(2)t, 91.0(1)-86.9(2)x14.6x7.0(1)-7.3(2)m, 5b,1vc(1)-4b,1vc(2), 4470(1)-5222(2)hp, 12.3(1)-13.2(2)kts, 490p; iron- 152belt, 25deck; 4x1-75/48, 8x1-37/20(1), 1-381TT(1), 600mines(1), 647mines(2)

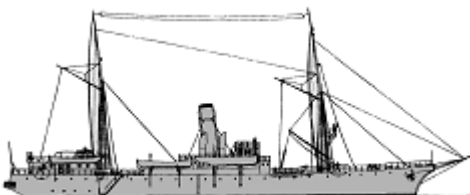
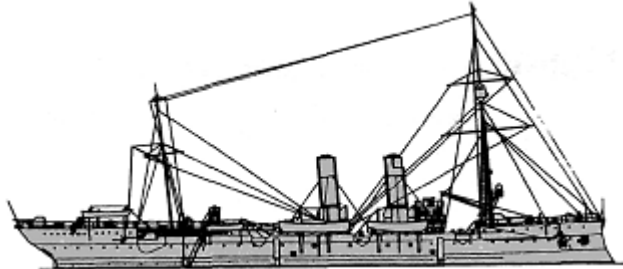
						
ML	Minin	1 3	Ladoga	1878		6100t, 89.9x15.1x7.7m, 18b,1vte, 4000hp, 12.2kts, 545p; compound- 178belt, 25deck; 4x1-47/40, 1080mines
	Aleut	1 4	Aleut	1886		892t, 49.4x9.4x3.5m, 2b,1vc, 730hp, 11.9kts, 100p; 4x5-37/17, 250mines
	Bug	1 5	Dunay	1893		1490t, 62.2x10.4x4.6m, 4b,2vte, 1400hp, 13kts, 226p; 4x1-47/40, 545mines
	Zagraditel	1 6	Zagraditel	1906		459t, 46.3x7.3x3.1m, 2b,1vte, 480hp, 9.5kts, 33p; mines
	Volga	1 7	Volga	1909		1711t, 70.3x11.9x4.4m, 4b,2vte, 1600hp, 13.5kts, 219p; 4x1-47/40, 230mines
	Amur	2 9	Enisey	1909		2926t, 98.9x14.0x4.4m, 12b,2vte, 5000hp, 16kts, 312p; 5x1-120/43, 2x1-75/48, 320mines

BOARD GUARD SHIPS

CG	Roksana	1	1	Roksana	1893	No picture	157t, 37.0x4.2x2.0m, 2b,1vte, 600hp, 12kts; 2x5-37/17
	Oryol	1	2	Oryol	1898	No picture	125t, 35.1x5.2x2.4m, 250hp, 12kts, 28p; 2x1-37/20
	Kondor	2	3	Kondor	1902	No picture	322t, 48.6x6.6x2.4m, 2vte, 1200hp, 13.5kts; 4x1-47/40, 2x1-37/20
4			Berkut	1904			
CB	Strazh	2	1	Strazh	1874	No picture	230t, 33.0x6.4x2.5m, 1vc, 300hp, 11kts, 36p; 1x1-87/17
			2	Chasovoy	1874		
	Yastreb	2	3, 4	Yastreb, Voron	1900	No picture	60t, 21.0x6.3x1.3m, 1vte, 150hp, 9kts; 1x1-76/14
	Korshun	1	5	Korshun	1900	No picture	100t, 30.5x6.1x1.5m, 1d, 225hp, 8kts, 36p; 2x1-37/20



© Ivan Gogin, 2014

[home](#)[World navies yesterday](#)[1910](#)

Sarawak 01 January 1910

OTHER FIGHTING SHIPS

PG	Aline	1	1	Aline	1875	No picture	175brt, 43.4x6.5m, 35hp; 2x1-small guns
	Lorna Doone	1	2	Lorna Doone	1881	No picture	118brt, 31.5x5.2m, 40hp, 2x1-small guns
	Aden	1	3	Aden	1884	No picture	300brt, 45.6x7.7m, (sw), 75hp; 1x1-small gun
	Kaka	1	4	Kaka	1901	No picture	400brt, (sw)

© Ivan Gogin, 2015



[home](#)[World navies yesterday](#)[1910](#)

Siam 01 January 1910

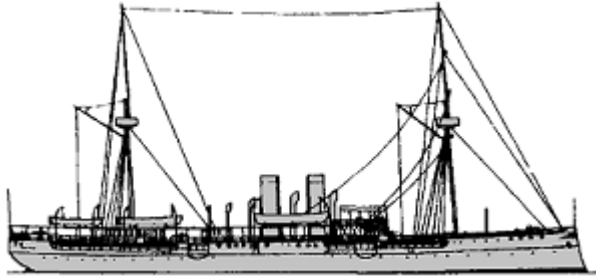
CRUISERS

CL	Maha Chakri	1	1	Maha Chakri	1893		2500t, 88.4x12.0x4.2m, 5b,2vte, 3000hp, 15kts, 318p; steel- 51deck; 4x1-120/40, 10x1-57/40
----	-------------	---	---	-------------	------	--	--

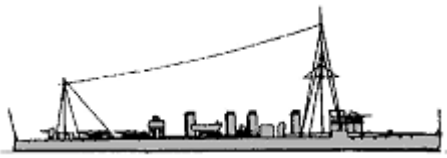
TORPEDO SHIPS

DD	Sua Tayanchon	1	1	Sua Tayanchon	1908		385t, 69.2ppx6.6x1.8m, 4b,2vte, 6000hp, 27kts, 75p; 1x1-76/40, 5x1-57/40, 2x1-450TT
TB	No1	3	1	No1	1908		100t, 41.1x4.9x2.1m, 2b,1vte, 1200hp, 23kts, 29p; 1x1-57/40, 1x1-47/40, 2x1-450TT
			2	No2	1908		
			3	No3	1908		

OTHER FIGHTING SHIPS

PG	Han Hak Sakru	1	1	Han Hak Sakru	1866	No picture	260t, 26.8x7.9x2.0m, 7kts; 1x1-102/27	
	Maida	1	2	Maida	1867	No picture	370t, 41.8x5.9x3.1m, 11kts; 1x1-121/21	
	Mongkut Rajakumarn	1	3	Mongkut Rajakumarn	1887	No picture	700t, 53.3x7.2x3.4m, 2b,2vte, 800hp, 14kts, 100p; 2x1-120/40, 4x1-57/40, 3x1-37/20, 1-356TT	
	Koh Si Chang	1	4	Koh Si Chang	1890	No picture	100t	
	Udhai Rajakich	1	5	Udhai Rajakich	1890	No picture	134t	
	Sathit Rajakarn	1	6	Sathit Rajakarn	1892	No picture		
	Theva Sooraram	1	7	Theva Sooraram	1898	No picture	115t	
	Muratha		3	8	Muratha	1898		530(8)-580(9,10)t, 44.2(8)-49.4(9,10)x7.0x3.1m, 2b,2vte, 500hp, 11.4kts, 83p; 1x1-120/40, 5x1-57/40, 4x1-37/20
				9	Bali	1900		
				10	Sugrib	1901		

	Sri Monthon	1	11	Sri Monthon	1908		225t, 41.8x5.5x2.0m, 1b,2vte, 7500hp, 14.5kts, 34p; 2x1-57/40
FB	Siam Mongkut	1	1	Siam Mongkut	1870	No picture	950t, 64.0m; iron- 63battery; 8x1-102/21
DV	Prap Porapak	1	1	Prap Porapak	1898	No picture	210t

© Ivan Gogin, 2015

[home](#)[World navies yesterday](#)[1910](#)

Spain 01 January 1910

BATTLESHIPS

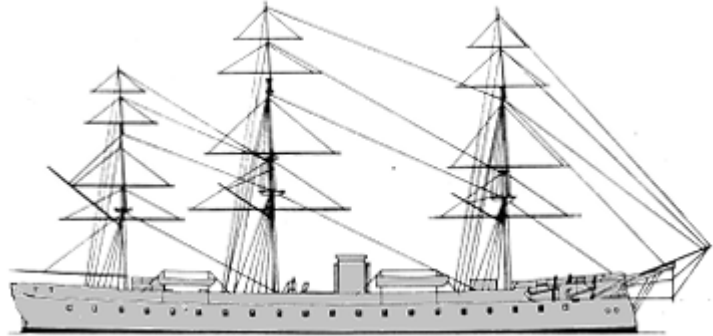
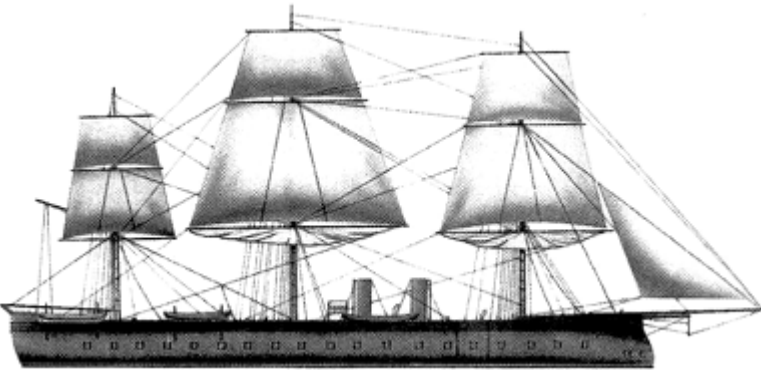
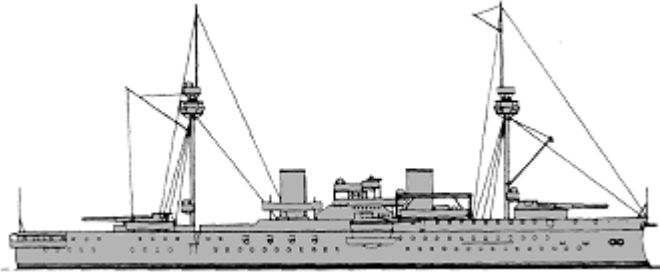
						7189t, 96.1x17.4x8.2m, 8b,1vc, 4500hp, 13kts, 500p; iron- 130belt, 120battery; 4x1-200/35, 3x1-150/48, 8x1-140/36, 12x1-47/40, 2-356TT
BB	Vitoria	1 2	Vitoria	1867		7135t, 96.4ppx17.4x8.1m, 8b,1hr, 4500hp, 12kts, 500p; iron- 130belt, 120battery; 4x1-200/35, 12x1-149/37, 8x1-57/42, 4x1-47/40, 4x1-37/27
	Pelayo	1 3	Pelayo	1888		9950t, 105.1x20.2x7.6m, 16b,2vc, 9473hp, 16kts, 520p; steel- 450belt, 70deck, 400barbettes, 155CT; 2x1-320/35, 2x1-280/35, 9x1-140/36, 5x1-57/42, 14x1-37/27, 3-381TT





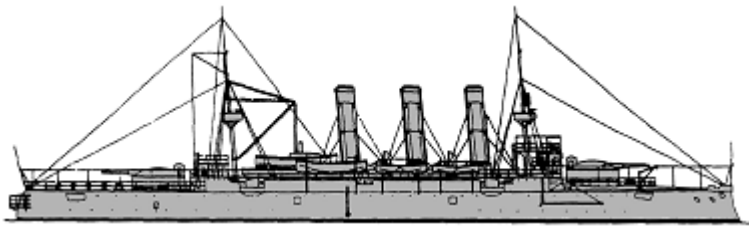
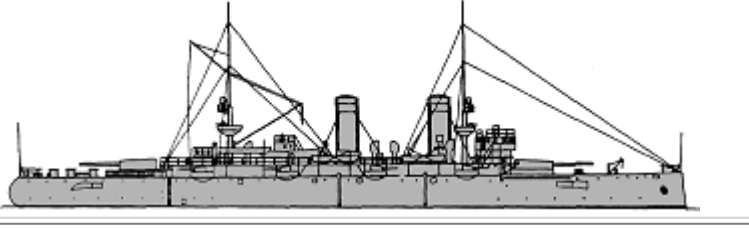
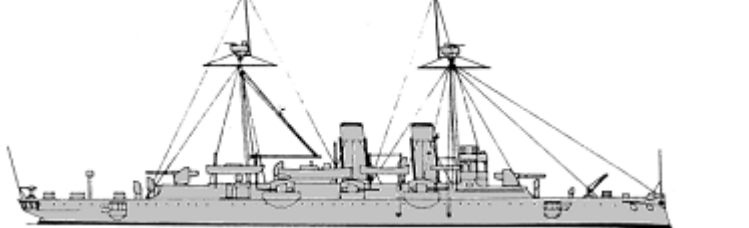
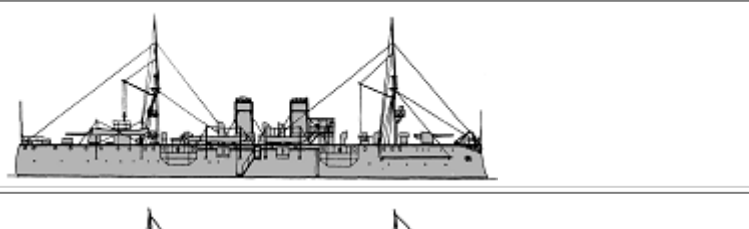
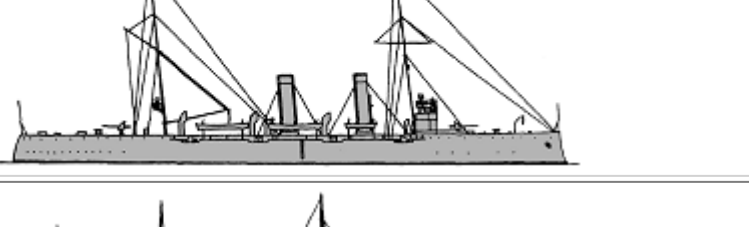
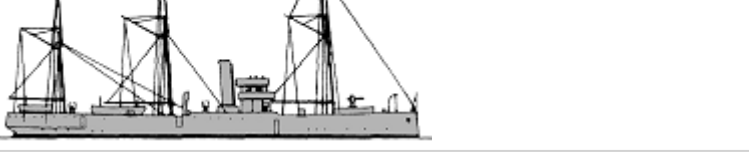

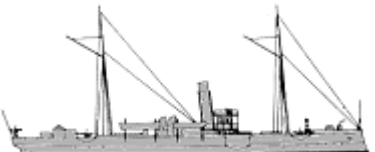

CRUISERS

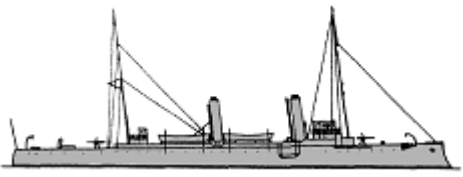
	Carlos V	1 1	Carlos V	1897		10100t, 115.8x20.4x7.6m, 12b,2vte, 18500hp, 20kts, 583p; 50belt, 50deck, 250barbettes, 300CT;
--	----------	-----	----------	------	--	---

CA					2x1-280/35, 8x1-140/36, 4x1-57/42, 2x1-42/43, 4x1-37/27, 6-356TT	
Princesa de Asturias	2	2	Princesa de Asturias	1903		7549t, 111.0x18.6x6.6m, 6b,2hte, 14800hp, 20kts, 542p; Harvey- 300belt, 57deck, 100turrets, 200CT; 2x1-240/41, 8x1-140/33, 8x1-57/42, 10x1-37/27, 5-450TT
		3	Cataluña	1904		
Reina Regente	1	1	Lepanto	1899		4725t, 97.1x15.2x6.2m, 4b,2hte, 11500hp, 20.4kts, 440p; steel- 120deck, 75shields; 4x1-200/35, 6x1-120/35, 6x1-57/42, 6x1-37/27, 5-356TT
Río de La Plata	1	2	Río de La Plata	1900		1950t, 76.3x10.8x4.4m, 2vte, 7100hp, 20kts, 213p; steel- 20slopes, 15deck, 120CT; 2x1-140/43, 4x1-100/56, 6x1-57/42, 2x1-37/27, 2-356TT
Extremadura	1	3	Extremadura	1902		2180t, 88.4x11.0x4.3m, 4b,2vte, 7000hp, 20kts, 246p; 50deck, 30CT; 8x1-101/50, 2x1-75/14, 4x1-57/42, 2x1-37/20
CLL Velasco	1	1	Infanta Isabel	1888		1152t, 67.4x9.8x3.9m, 4b,1hc, 1500hp, 13kts, 173p; 4x1-120/35, 4x5-37/17, 4x1-25/40, 2-356TT

TORPEDO SHIPS

PGT	Temerario	1	Temerario	1891		630t, 58.0ppx6.7x3.2m, 2b,2vte, 2600hp, 19kts, 91p; steel- 13deck; 2x1-120/35, 4x1-57/42, 1x4-25/42, 2x1-356TT
		2	Nueva España	1891		
		3	Marqués de Molins	1894		
		4	Martín Alonzo Pinzón	1893		
		5	Vicente Yáñez Pinzón	1894		

	María de Molina	6	María de Molina	1898		830t, 71.6ppx8.0x2.7m, 4b,2vte, 3500hp, 19.5kts, 91p; 152CT; 2x1-120/35, 4x1-42/42, (1+2x1)-356TT	
		7	Marqués de la Victoria	1900			
		8	Álvaro de Bazán	1900			
DD	Furor	1	1	Terror	1896		450t, 67.1ppx6.7x1.7m, 4b,2vte, 6000hp, 28kts, 67p; 2x1-75/42, 2x1-57/42, 2x1-37/27, 2x1-356TT
	Audaz	2	Audaz	1898		430(2,3)-457(4)t, 69.8x6.9x1.8m, 4b,2vte, 7500hp, 30kts, 67p; 2x1-75/42, 2x1-57/42, 2x1-37/27, 2x1-356TT	
		3	Osado	1898			
4		Proserpina	1898				
TB	Acevedo	2	1, 2	No12, 13	1885		65t, 36.5x3.8x1.7m, 1b,1vc, 660hp, 20.5kts, 17p; 2x5-25/42, 2-356TT
	Orión	1	3	No11	1886		88t, 38.0x4.8x2.0m, 1b,1vc, 1000hp, 21kts, 18p; 2x5-25/42, 2-356TT
	Barceló	2	4, 5	No9, 14	1886-1887		65t, 38.0x3.1x2.2m, 1b,1vc, 800hp, 20kts, 17p; 2x1-47/40(8), 2x5-25/42(7), 2-356TT
	Habana	1	6	No15	1887		67t, 38.9x3.8x1.6m, 1b,1vc, 730hp, 24.5kts, 17p; 1x5-25/42, 2-356TT
	Azor	2	7	No1	1887		108t, 41.1x4.2x2.1m, 1b,1vc, 1300hp, 24kts, 23p; 3x1-42/42, 2-356TT
8			No2	1887			

OTHER FIGHTING SHIPS

PG	General Concha	1	1	General Concha	1885	No picture	620t, 50.4x7.9x3.4m, 2b,2vc, 600hp, 11kts, 98p; 3x1-120/25, 2x4-25/42
	Mac-Mahón	1	2	Mac-Mahón	1888	No picture	115t, 27.6x4.9x1.8m, 2b,2vte, 150hp, 9kts, 15p; 2x1-42/42, 1x5-37/17
	Hernan Cortés	2	3	Hernan Cortés	1895	No picture	295t, 47.4x6.6x1.9m, 1b,1vte, 352hp, 13kts, 53p; 2x1-75/42, 2x1-57/42
			4	Vasco Núñez de Balboa	1895		
Ponce de Leon	1	5	Ponce de Leon	1896	No picture	200t, 41.4x5.8x1.8m, 2b,2vte, 230hp, 12kts, 38p; 2x1-57/42	
PR	Perla	1	1	Perla	1889	No picture	42t, 19.0x3.6x1.8m, 110hp, 7kts, 26p; 1x2-25/42
	Cartagenera	1	2	Cartagenera	1908		27t, 16.3x3.6x1.2m, 1b,1vc, 120hp, 12kts; 1x1-42/42

MINE WARFARE SHIPS

ML	Anteo	1	1	Anteo	1903	No picture	342t, 40.0x6.6x2.1m, 1b,1vte, 650hp, 11kts; 40mines, sweeps
----	-------	---	---	-------	------	------------	---

[home](#)[World navies yesterday](#)[1910](#)

Sweden 01 January 1910

BATTLESHIPS

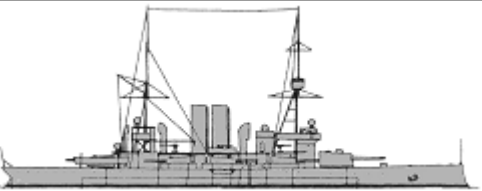
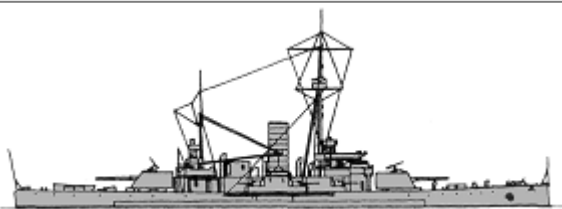
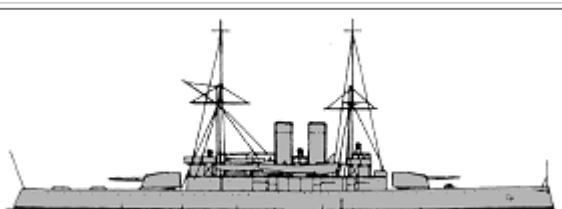
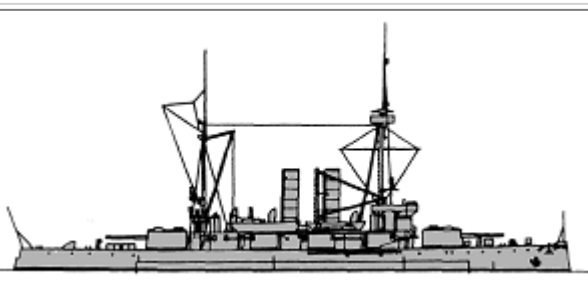
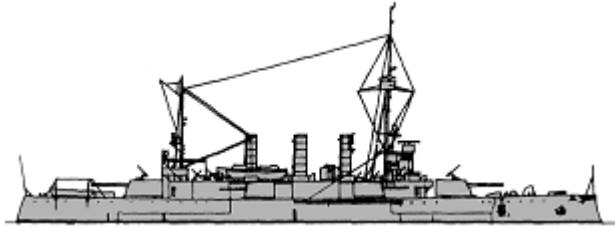



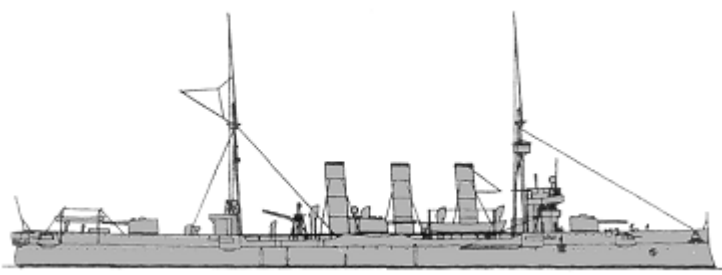

BC	Svea	1	Svea	1886		3273(1)-3300(2,3)t, 75.7(1)-78.8(2)-79.5(3)x14.8(1)-14.6(2,3)-5.1m, 6b,2vc, 3640(1)-4700(2,3)hp, 14.7(1)-16(2,3)kts, 252p; compound(1)-steel(2,3)- 297(1)-293(2,3)belt, 49deck, 190(KC)turret; 1x1-209/43, 7x1-152/43, 11x1-57/50	
		2	Göta	1891			
		3	Thule	1893			
	Oden	4	Oden	1897		3715(4)-3720(5,6)t, 86.3x14.8x5.3m, 6b,2vte, 5350hp, 16.5kts, 254p; steel(4)-Harvey(5,6)- 243(4)-240(5,6)belt, 49deck, 200(4)-190(5,6)turrets, 247(4)-190(5,6)CT; 2x1-254/41, 4x1-120/43(4), 6x1-120/43(5,6), 10x1-57/52, 2x2-25/32, 1-450TT	
		5	Thor	1899			
		6	Njord	1899			
	Dristigheten	1	7	Dristigheten	1901		3600t, 89.0x14.8x4.9m, 8b,2vte, 5400hp, 16.5kts, 275p; Harvey- 200belt, 50deck, 200turrets, 247CT; 2x1-209/43, 6x1-152/43, 10x1-57/50, 2-450TT
	Äran	8	Äran	1902		3735t, 89.7x15.0x5.0m, 8b,2vte, 6500hp, 17kts, 275p; 175belt, 48deck, 190turrets, 200CT; 2x1-209/43, 6x1-152/43, 10x1-57/50, 2x1-37/34, 2-450TT	
		9	Wasa	1902			
		10	Tapperheten	1903			
11		Manligheten	1904				
Oscar II	1	12	Oscar II	1907		4584t, 95.6x15.4x5.5m, 10b,2vte, 9400hp, 18kts, 331p; 150belt, 50deck, 190turrets, 157CT; 2x1-209/43, 4x2-152/49, 10x1-57/50, 3x1-37/34, 2-450TT	
MON	John	1	John Ericsson	1865		1476t, 60.8x13.8x3.7m, 2b,1vde, 380hp, 7kts, 80p; iron- 125(1)-118(2,3)belt, 48(1)-25(2,3)deck, 270(1)-261(2,3)turret, 250(1)-237(2,3)CT; 2x1-152/30(1), 1x2-120/43(2,3), 8x1-57/50(3), 6x1-57/46(1), 8x1-	



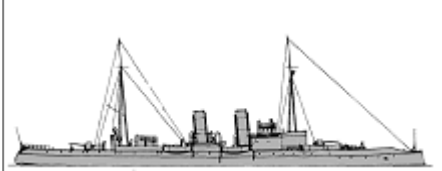

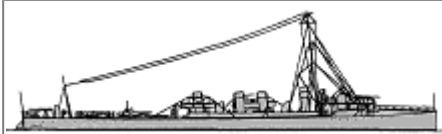
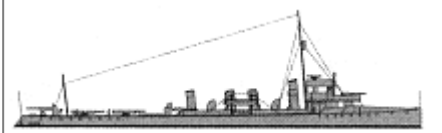



Ericsson	2	Thordön	1866		47/49(2)
	3	Tirfing	1867		

CRUISERS



CA	Fylgia	1	1	Fylgia	1907		4734t, 115.1x14.8x6.3m, 12b,2vte, 12000hp, 21.5kts, 320p; 100belt, 35deck, 125turrets, 100CT; 4x2-152/49, 14x1-57/50, 2-450TT
----	--------	---	---	--------	------	--	---

TORPEDO SHIPS



PGT	Örnen	5	1	Örnen	1897		844(1)-846(2)-835(3)-814(4)-800(5)t, 67.7(1-3)-70.7(4,5)x8.2(1-3)-8.3(4,5)x3.1(1-3)-3.0(4,5)m, 8b,2vte, 4000hp, 20kts, 113p; 2x1-120/43, 4x1-57/50, 1-381TT
			2	Claes Horn	1898		
			3	Jacob Bagge	1898		
			4	Psilander	1900		
			5	Claes Ugglå	1900		
DD	Mode	1	1	Mode	1902		453t, 67.1x6.2x2.7m, 4b,2vte, 6000hp, 30kts, 62p; 6x1-57/50, 2x1-450TT
	Magne	1	2	Magne	1905		460t, 65.8x6.3x2.5m, 4b,2vte, 7200hp, 30kts, 67p; 6x1-57/50, 2x1-450TT
	Wale	1	3	Wale	1908		461t, 66.1x6.3x2.8m, 4b,2vte, 7665hp, 30kts, 54p; 2x1-75/49, 4x1-57/50, 2x1-450TT
	Ragnar	2	4	Ragnar	1909		460t, 66.1x6.3x2.7m, 4b,2vte, 7200hp, 30kts, 54p; 2x1-75/49, 4x1-57/50, 2x1-450TT
			5	Sigurd	1909		
	Hugin	1	1	Hugin	1884		64t, 34.5x3.8x2.0m, 1b,1vc, 620hp, 18.5kts; 1x1-25/32, 2-381TT
	Munin	3	2-4	Munin, Freke, Gere	1887		66t, 34.8x3.8x2.0m, 1b,1vc, 620hp, 18.5kts; 1x1-25/57, 2-381TT
	Gondul	2	5, 6	Gondul, Gudur	1894		86t, 38.6x4.3x2.1m, 1b,1vc, 850hp, 19.5kts, 18p; 2x1-25/57, (1+1x1)-381TT
			7	Komet	1896		
			8	Blixt	1898		
			9	Meteor	1899		
			10	Stjerna	1899		

TB 1cl	Komet	12	11	Orkan	1900		120t, 39.8x4.8x2.5m, 1b,1vc, 1300hp, 23kts, 18p; 2x1-37/37, (1+1x1)-381TT	
			12	Bris	1900			
			13	Vind	1900			
			14	Virgo	1902			
			15	Mira	1902			
			16	Orion	1903			
			17	Sirius	1903			
			18	Kapella	1904			
	Plejad	12	19	Plejad	1905		106t, 40.2x4.4x2.6m, 2b,1vte, 2000hp, 26kts, 25p; 2x1-37/37, (1+1x1)-450TT	
			20	Iris	1908			
			21	Thetis	1908			
			22	Spica	1908			
			23	Astrea	1908			
			24	Antares	1909			
			25	Arcturus	1909			
			26	Altair	1909			
			27	Argo	1909			
			28	Polaris	1909			
			29	Castor	1909			
			30	Pollux	1909			
	TB2cl	Rolf	1	1	Blink	1882		38t, 27.9xxm, 1b,1vc, 350hp, 16kts; 1x1-25/32, 2-356TT
		Blixt	2	2, 3	Blixt, Galdr	1883-1885		43t, 30.5xxm, 1b,1vc, 420hp, 19kts; 1x1-25/32, 2-356TT
		Narf	2	4, 5	Narf, Nörve	1886		45t, 30.5x3.6x1.9m, 1b,1vc, 440hp, 19.5kts; 1x1-25/32, 2-356TT
		Bygve	2	6, 7	Bygve, Bylgia	1887		57t, 31.5x3.6x1.9m, 1b,1vc, 460hp, 18.5kts; 1x1-25/58, 2-381TT
		Agne	2	8, 9	Agne, Agda	1891-1892		55t, 30.6x3.6x1.9m, 1b,1vc, 460hp, 18.9kts; 1x1-25/58, (1+1x1)-381TT
		N:o79	2	10,11	N:o79, 81	1903		55t, 31.7x3.6x1.9m, 1b,1vc, 700hp, 20.5kts; 1x1-37/37, (1+1x1)-381TT
		N:o83	2	12,13	N:o83, 85	1903		56t, 32.4x3.6x1.9m, 1b,1vc, 635hp, 20.8kts; 1x1-37/37, (1+1x1)-381TT

SUBMARINES

SS	Hajen	1	1	N:r1	1905		111/127t, 21.6x3.6x3.0m, 1pe/em, 200/70hp, 9.5/7kts, 11p, 30m; 1-450TT
	Hvalen	1	2	Hvalen	1909		186/230t, 42.4x4.3x2.7m, 3pe/1em(1), 750/150hp, 14.8/6.3kts, 17p, 30m; 2-450TT
	N:r2	2	3	N:r2	1909		138/230t, 26.8x3.6x3.0m, 1d/em, 420/200hp, 8.8/6.6kts, 12p, 30m; 1-450TT
			4	N:r3	1909		

OTHER FIGHTING SHIPS

MONL	Gerda	2	1	Gerda	1872		459t, 39.7x8.0x2.5m, 2b,2hc, 133hp, 7.6kts, 42p; iron- 76belt, 418turret, 254CT; 1x1-120/44, 2x1-25/32
			2	Hildur	1872		
	Ulf	5	3	Ulf	1873		460t, 39.8x8.0x2.5m, 2b,2hc, 155hp, 8kts, 42p; iron- 76belt, 418turret, 254CT; 1x1-120/44, 2x1-57/50
			4	Björn	1874		
			5	Berserk	1874		
			6	Sölve	1875		
			7	Folke	1875		
PG	Blenda	1	1	Disa	1877	No picture	550t, 51.1x8.1x3.0m, 2b,2hc, 590hp, 11.5kts, 71p; 51CT; 1x1-152/25, 2x1-57/50(3)
			2	Urd	1877	No picture	550t, 53.6x8.1x2.8m, 2b,2hc, 780hp, 72p; 51CT(2,3,5); 1x1-152/30(2,3,5), 1x1-120/43, 2x1-57/50(2,3,5)
	3	Skagul	1878				
	4	Skuld	1881				
	5	Skäggard	1879				
	Svenskund	1	6	Svenskund	1891	No picture	280t, 38.5x7.9x3.0m, 440hp, 12.5kts; 2x1-57/50, mines

MINE WARFARE SHIPS

ML	Ångkranpramen N:r3	1	1	Ångkranpramen N:r3	1879	No picture	190t, 6.5kts; mines
	Ångkranpramen N:r3	4	2	Ångkranpramen N:r5	1904	No picture	120t, 7.5kts; mines
			3	Ångkranpramen N:r6	1904		
			4	Ångkranpramen N:r7	1904		
			5	Ångkranpramen N:r7	1905		
	Edda	1	6	Edda	1885	No picture	640t, 55.8x8.3x3.1m, 2b,2vc, 960hp, 13.5kts, 76p; 4x1-57/50, mines

[home](#)[World navies yesterday](#)[1910](#)

United Kingdom 01 January 1910

BATTLESHIPS

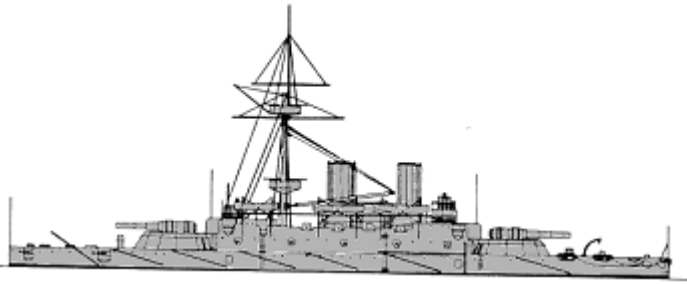
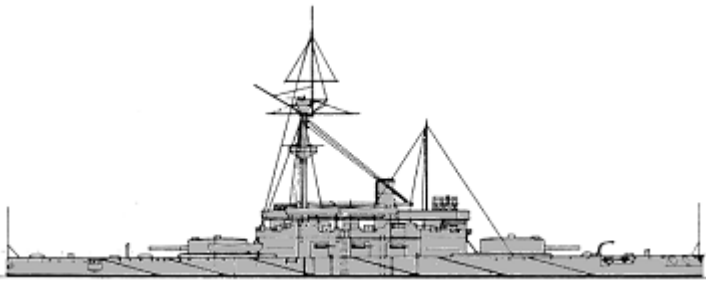
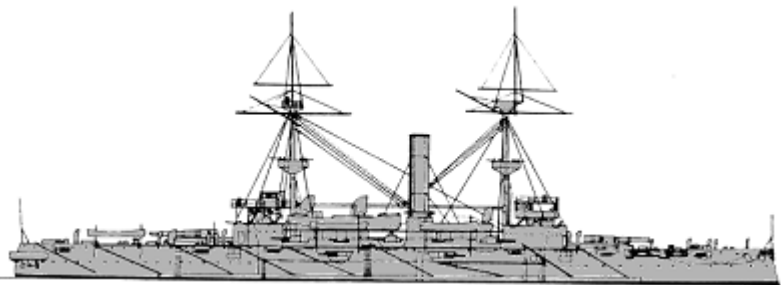

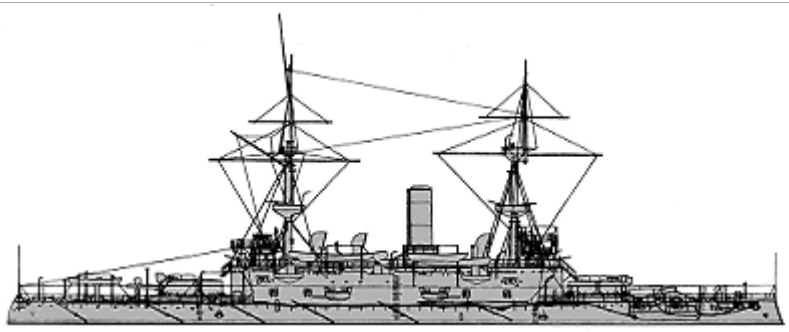
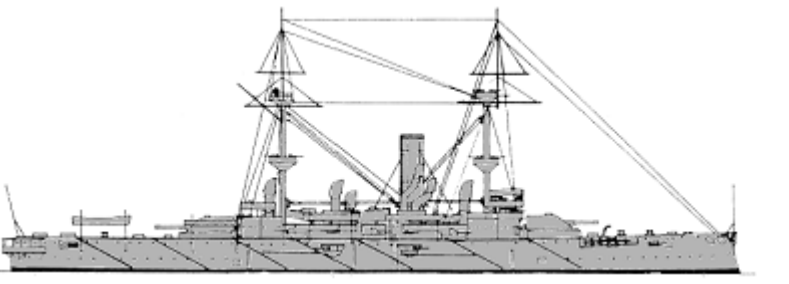
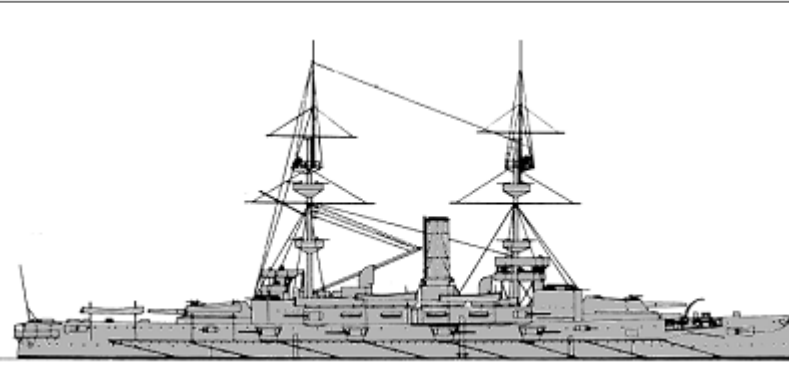
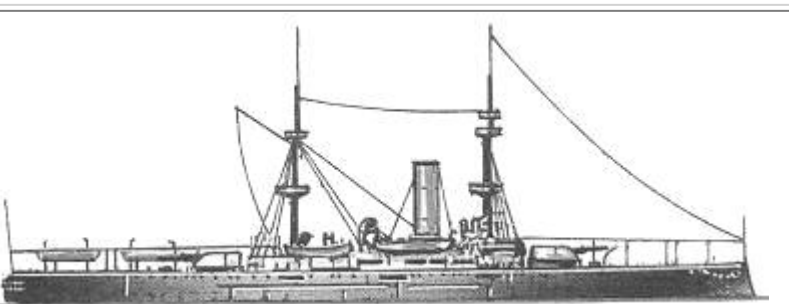
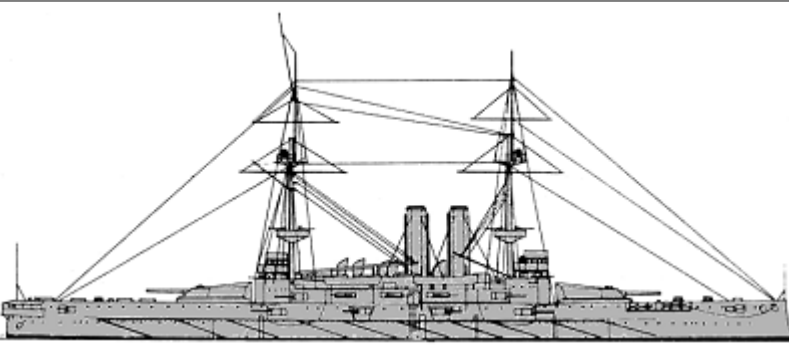
Rodney	1	1	Howe	1889		10300t, 99.1ppx20.7x8.5m, 12b,3ice, 11500hp, 17kts, 530p; compound: 457belt, 76decks, 292barbettes, 305CT; 2x2-343/30, 6x1-152/27, 12x1-57/40, 10x1-47/40, 5-356TT
Trafalgar	2	2	Trafalgar	1890		12590t, 105.2ppx22.3x8.7m, 6b,2vte, 12000hp, 16.7kts, 577p; compound: 508belt, 76deck, 457turret, 356CT; 2x2-343/30, 6x1- 152/40, 8x1-57/40, 9x1-47/40, 4-356TT
		3	Nile	1891		
Royal Sovereign	7	4	Royal Sovereign	1892		15580t, 125.0x22.9x8.4m, 8b,2vte, 11000hp, 16.5kts, 712p; compound: 457belt, 76deck, 432barbettes, 356CT; 2x2-343/30, 10x1-152/40, 16x1-57/40, 12x1-47/40, 7-450TT
		5	Empress of India	1893		
		6	Repulse	1894		
		7	Ramillies	1893		
		8	Resolution	1893		
		9	Revenge	1894		
		10	Royal Oak	1894		
Hood	1	11	Hood	1893		15590t, 125.0x22.9x8.3m, 8b,2vte, 11000hp, 16.7kts, 690p; compound: 457belt, 76deck, 432turrets, 356CT; 2x2-343/30, 10x1- 152/40, 10x1-57/40, 12x1-47/40, 1-450TT

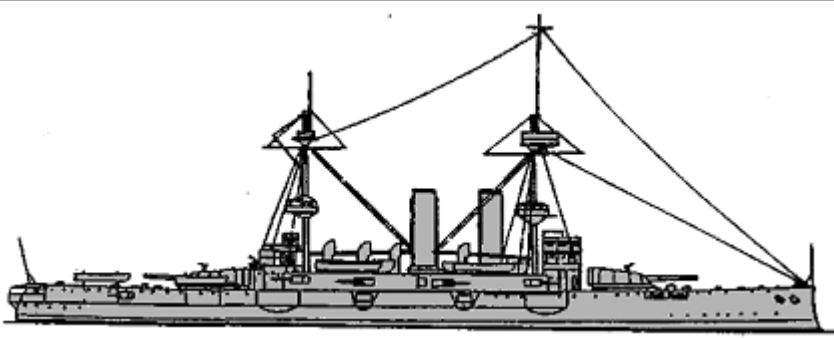
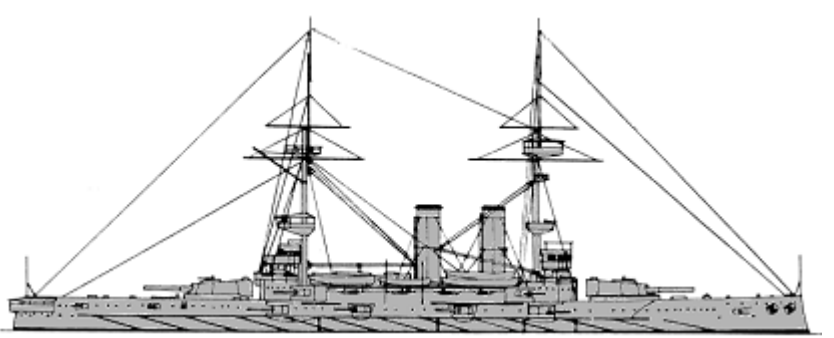
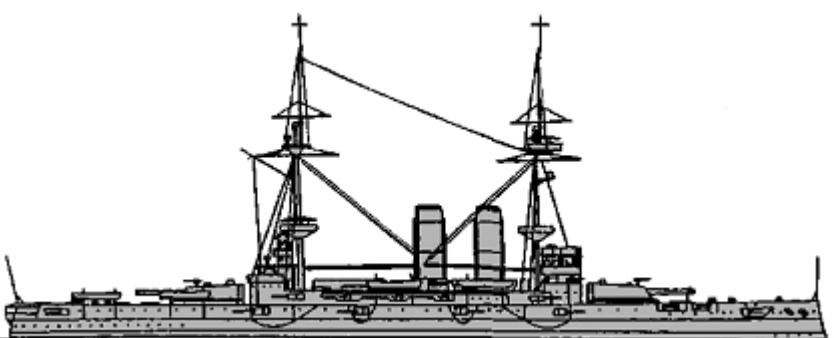
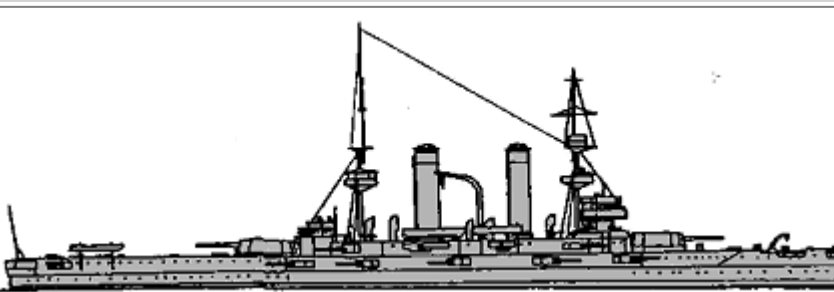
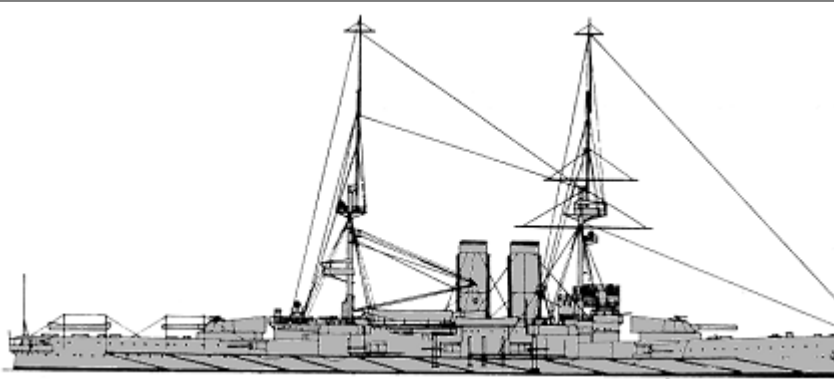
						
Centurion	2	12	Centurion	1894		10500t, 109.7ppx21.3x7.8m, 8b,2vte, 13000hp, 18.5kts, 620p; compound: 305belt, 64(NS)deck, 152(Harvey) gun houses, 305CT; 2x2-254/32, 10x1-152/40, 8x1-57/40, 12x1-47/40, 2-450TT
		13	Barfleur	1894		
Majestic	9	14	Magnificent	1895		15730-16060T, 128.3X22.9X8.2m, 8b,2vte, 12000hp, 17kts, 672p; Harvey: 229belt, 102deck, 254gunhouses, 356CT; 2x2-305/35, 12x1-152/40, 16x1-76/40, 12x1-47/40, 5-450TT
		15	Majestic	1895		
		16	Prince George	1896		
		17	Victorious	1896		
		18	Jupiter	1897		
		19	Mars	1897		
		20	Hannibal	1898		
		21	Caesar	1898		
		22	Illustrious	1898		
Renown	1	23	Renown	1897		12350t, 124.4x22.0x8.2m, 8b,2vte, 12000hp, 18kts, 674p; Harvey: 203belt, 76deck, 152gunhouses, 229CT; 2x2-254/32, 12x1-76/40, 12x1-47/40, 5-450TT
Canopus	6	24	Canopus	1899		14300t, 128.5x22.6x8.0m, 20b,2vte, 13500hp, 18kts, 682p; Harvey: 152(Krupp)belt, 76deck, 203(24-28)-203(Krupp, 29)gunhouses, 305CT; 2x2-305/35, 12x1-152/40, 10x1-76/40, 6x1-47/40, 4-450TT
		25	Goliath	1900		
		26	Albion	1901		
		27	Ocean	1900		
		28	Glory	1900		
		29	Vengeance	1902		
		30	Formidable	1901		
		31	Irresistible	1902		

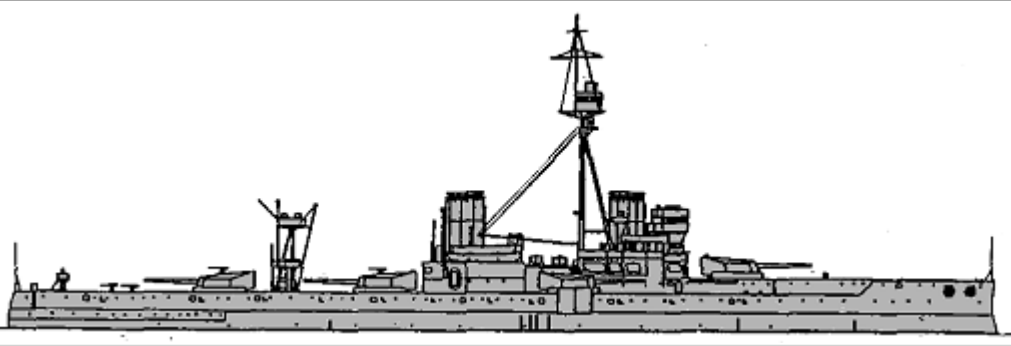
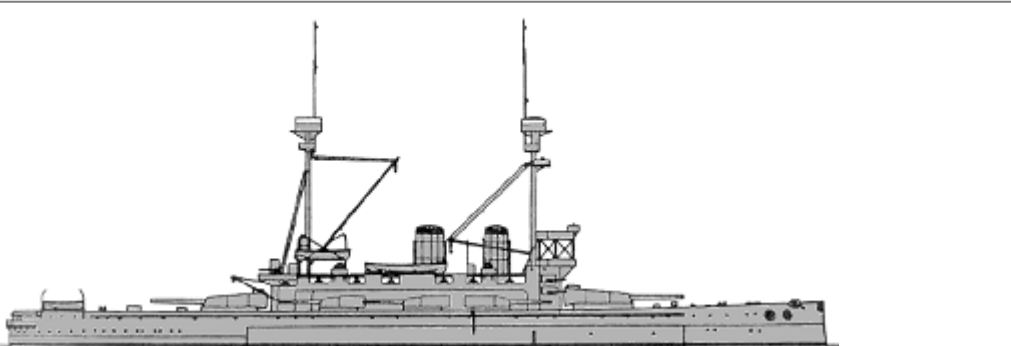
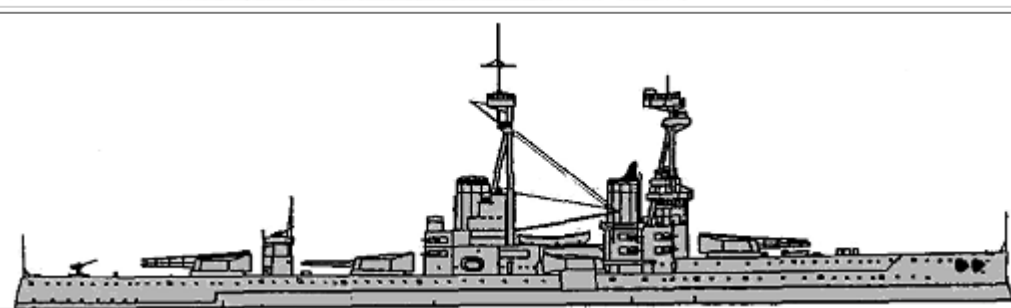
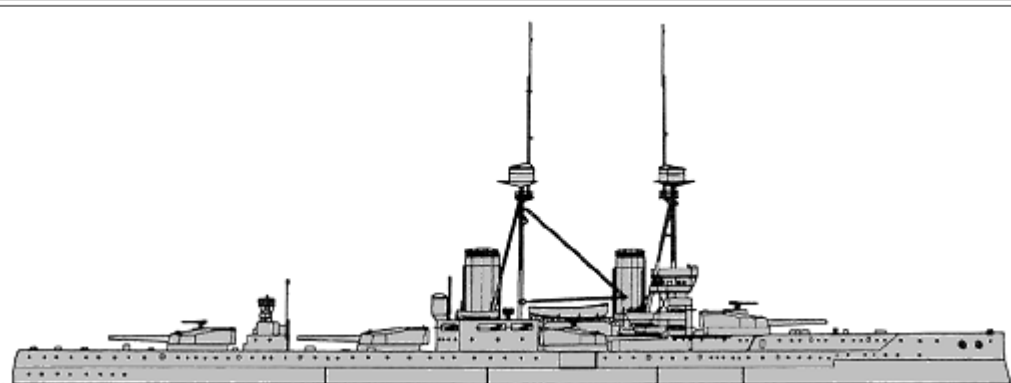
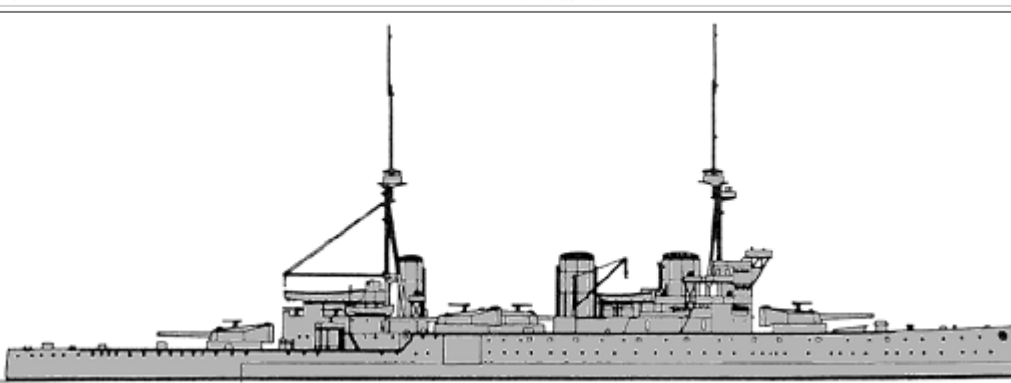
BB	Formidable	3				<p>15800t, 131.6x22.9x7.9m, 20b,2vte, 15000hp, 18kts, 780p; 229belt, 76decks, 254turrets, 356CT; 2x2-305/40, 12x1-152/45, 16x1-76/40, 6x1-47/40, 4-450TT</p>
			32	Implacable		
London	5	33	London	1902		<p>15700(33-35)-15400(36,37)t, 131.6x22.9x7.9m, 20b,2vte, 15000hp, 18kts, 714p; 229belt, 64decks, 254turrets, 356CT; 2x2-305/40, 12x1-152/45, 16x1-76/40, 6x1-47/40, 4-450TT</p>
		34	Bulwark	1902		
		35	Venerable	1902		
		36	Queen	1904		
		37	Prince of Wales	1904		
Duncan	5	38	Russell	1903		<p>14900-15200t, 131.7x23.0x7.9m, 24b,2vte, 18000hp, 19kts, 720p; 178belt, 51decks, 254turrets, 305CT; 2x2-305/40, 12x1-152/45, 10x1-76/40, 6x1-47/40, 4-450TT</p>
		39	Albermarle	1903		
		40	Duncan	1903		
		41	Cornwallis	1904		
		42	Exmouth	1903		
Swiftsure	2	43	Swiftsure	1904		<p>11800(43)-11985(44)t, 146.2x21.6x7.7m. 12b,2vte, 12500hp, 19kts, 800p; 178belt, 76decks, 254turrets, 279CT; 2x2-254/45, 14x1-190/50, 14x1-76/50, 6x1-57/50, 2-450TT</p>
		44	Triumph	1904		
King Edward VII	8	45	Commonwealth	1905		<p>17009-17290t, 138.3x23.8x7.7m, 16b,1vte(45-47)-15b,2vte(48-52), 18000hp, 18.5kts, 777p; 229belt, 64decks, 305turrets, 305CT; 2x2-305/40, 4x1-234/47, 10x1-152/45(45-47), 10x1-152/50(48-52), 14x1-76/45(45-49), 14x1-76/50(50-52), 14x1-47/40(45-47), 14x1-47/50(48-52), 4-450TT</p>
		46	King Edward VII	1905		
		47	Dominion	1905		
		48	Hindustan	1905		
		49	New Zealand	1905		
		50	Britannia	1906		
		51	Africa	1906		
52	Hibernia	1907				

	Dreadnought	1	53	Dreadnought	1906		21845t, 160.6x25.0x9.4m, 18b,4st, 23000hp, 21kts, 773p; 279belt, 76decks, 279turrets, 279CT; 5x2-305/45, 24x-76/50, 5-450TT
	Agamemnon	2	54	Agamemnon	1908		17820(54)-17683(55)t, 135.2x24.2x7.9m, 15b,2vte, 16750hp, 18kts, 800p; 305belt, 102deck, 305turrets, 305CT; 2x2-305/45, (4x2+2x1)-234/50, 24x1-76/50, 2x1-47/40, 5-450TT
			55	Lord Nelson	1908		
	Bellerophon	3	56	Bellerophon	1909		22102t, 160.3x25.2x8.3m, 18b,4st, 23000hp, 20.7kts, 733p; 254belt, 102decks, 279turrets, 279CT; 5x2-305/45, 16x1-102/50, 4x1-47/40, 3-450TT
			57	Temeraire	1909		
			58	Superb	1909		
	St. Vincent	1	59	St. Vincent	1909		23030t, 163.4x25.6x8.5m, 18b,4st, 24500hp, 21kts, 718p; 254belt, 76deck, 279turrets, 279CT; 5x2-305/50, 20x1-102/50, 4x1-47/40, 3-450TT
CB	Invincible	3	1	Indomitable	1908		20078t, 172.8x22.1x8.0m, 31b,st, 41000hp, 25.5kts, 784p; 152belt, 64deck, 178turrets, 254CT; 4x2-305/45, 16x1-102/40, 5-450TT
			2	Invincible	1909		
			3	Inflexible	1908		

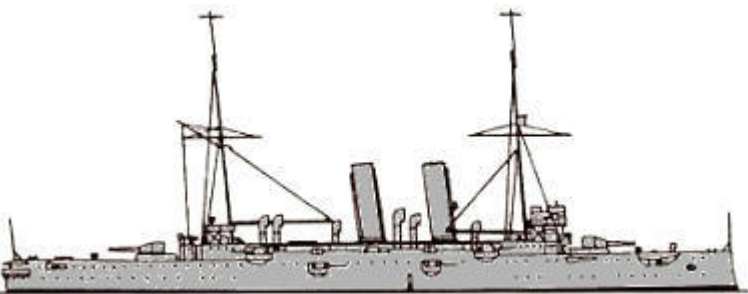
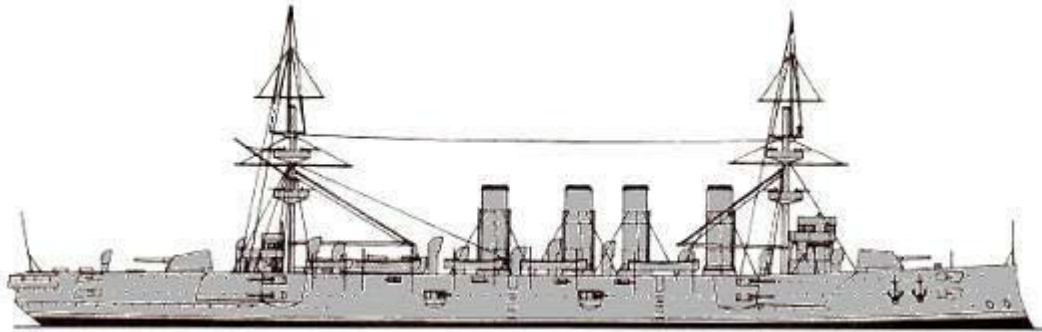
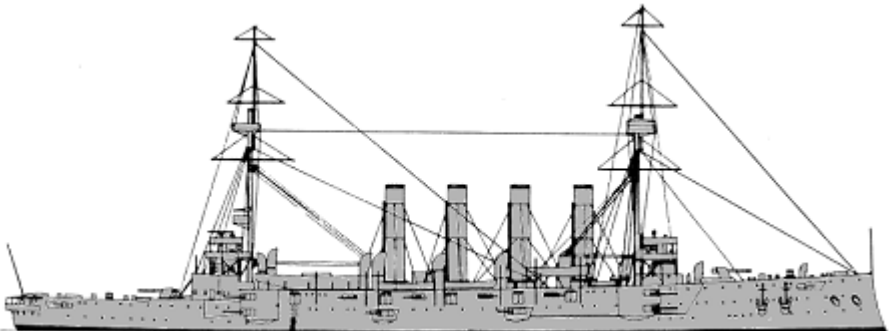
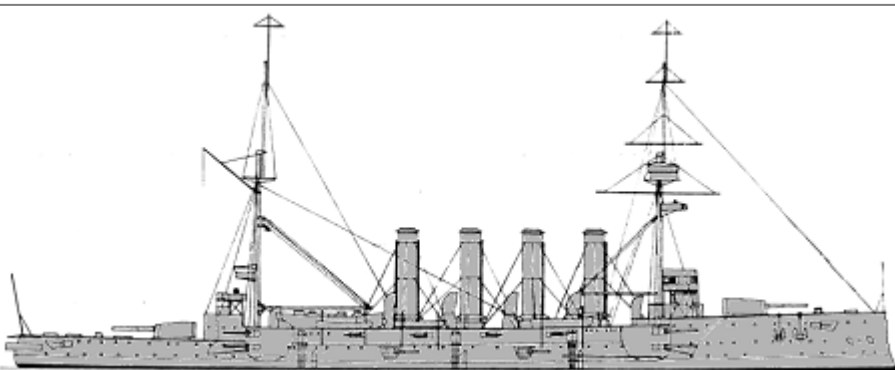
CRUISERS

Edgar	9	1	Edgar	1893		7350(1,3-5,9)-7700(2,6-8)t, 118.1x18.3x7.2m, 5b,2vte, 12000hp, 20kts, 544p; steel: 127deck, 152casemates, 305CT; 2x1-234/32(1,3-5,7-9), 1x1-234/32(2,6), 10x1-152/40(1,3-5,7-9), 12x1-152/40(2,6), 12x1-57/40, 5x1-47/40, 4-450TT
		2	Royal Arthur	1893		
		3	Hawke	1893		
		4	Endymion	1894		
		5	Grafton	1894		
		6	Crescent	1894		
		7	Gibraltar	1894		
		8	St. George	1894		
		9	Theseus	1896		
Powerful	2	10	Terrible	1898		14200t, 164.0x21.6x7.3m, 48b,2vte, 25000hp, 22kts, 894p; Harvey: 152deck, 152turrets, 305CT; 2x1-234/41, 16x1-152/40, 14x1-76/40, 12x1-47/40, 4-450TT
		11	Powerful	1897		
Diadem	8	12	Diadem	1898		11000t, 141.0x21.0x7.8m, 30b,2vte, 16500(12-15)-18000(16-20)hp, 20.2(12-15)-20.7(16-20)kts, 677p; Harvey: 102deck, 114casemates, 305CT; 16x1-152/40, 14x1-76/40, 3x1-47/40, 3-450TT
		13	Niobe	1898		
		14	Europa	1899		
		15	Andromeda	1899		
		16	Amphitrite	1901		
		17	Argonaut	1900		
		18	Ariadne	1902		
		19	Spartiate	1903		
Cressy	6	20	Sutlej	1902		12000t, 143.9x21.2x7.9m, 30b,2vte, 21000hp, 21kts, 760p; 152belt, 76deck, 152turrets, 305CT; 2x1-234/47, 12x1-152/45, 12x1-76/40, 3x1-47/40, 2-450TT
		21	Cressy	1901		
		22	Aboukir	1902		
		23	Hogue	1902		
		24	Bacchante	1902		
		25	Euryalus	1904		
		26	Good Hope	1902		14150t, 162.6x21.7x7.9m, 43b,2vte, 30000hp, 23kts, 900p; 152belt,
		27	Drake	1903		
		28	Leviathan	1903		

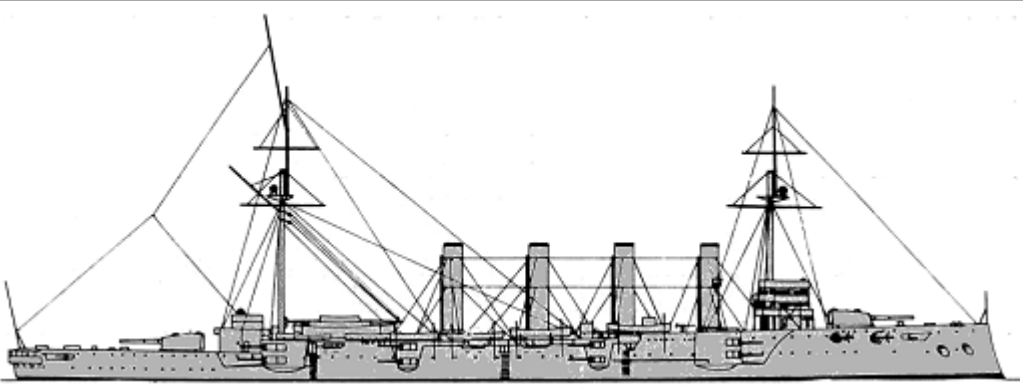
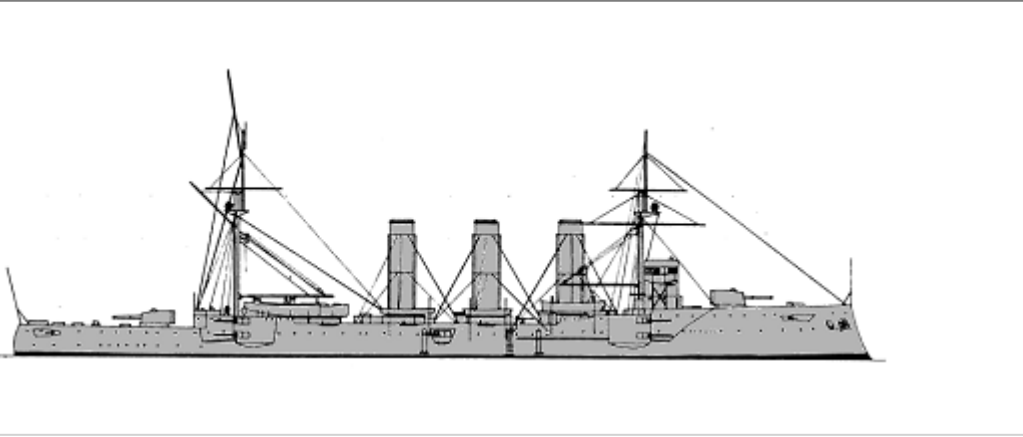
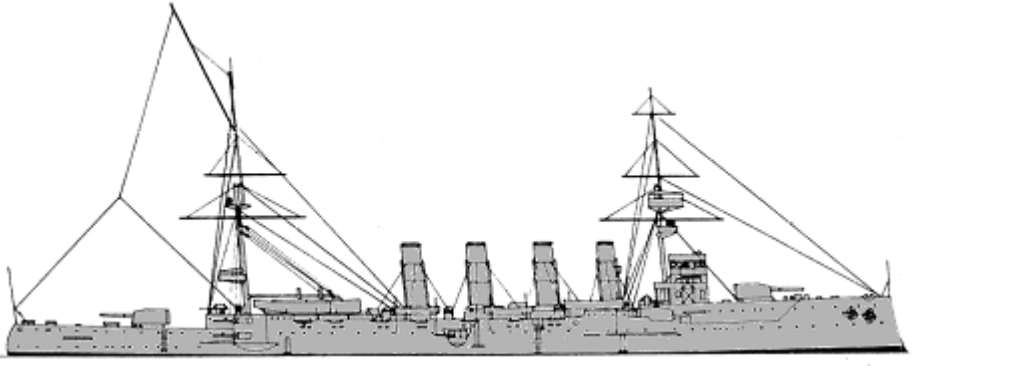
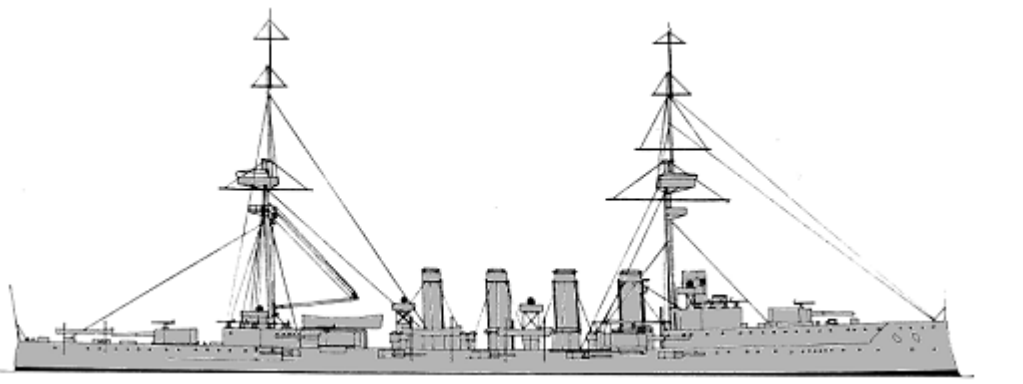
CA	Drake	4				64deck, 152turrets, 305CT; 2x1-234/47, 16x1-152/45, 14x1-76/40, 3x1-47/40, 2-450TT	
	Monmouth	10	29	King Alfred	1903		9800t, 141.3x20.1x7.6m, 31b,2vte, 22000hp, 23kts, 678p; 102belt, 51deck, 127turrets, 254CT; (2x2+10x1)-152/45, 10x1-76/40, 3x1-47/40, 2-450TT
			30	Kent	1903		
			31	Essex	1904		
			32	Bedford	1903		
			33	Monmouth	1903		
			34	Donegal	1903		
			35	Berwick	1903		
			36	Cornwall	1904		
			37	Cumberland	1904		
38			Lancaster	1904			
39	Suffolk	1904					
Hampshire	6	40	Hampshire	1905		10850t, 144.3x20.9x7.3m, 15-17b, 2vte, 21000hp, 22kts, 655p; 152belt, 51deck, 127turrets, 305CT; 4x1-190/45, 6x1-152/45, 2x1-76/40, 18x1-47/50, 2-450TT	
		41	Carnarvon	1905			
		42	Antrim	1905			
		43	Roxburgh	1905			
		44	Argyll	1905			
		45	Devonshire	1905			
Duke of Edinburgh	2	46	Duke of Edinburgh	1906		13550t, 154.1x22.4x7.9m, 20b, 2vte, 23000hp, 23kts, 790p; 152belt, 38deck, 190turrets, 254CT; 6x1-234/47, 10x1-152/50, 22x1-47/50, 3-450TT	
		47	Black Prince	1906			
		48	Warrior	1906			
		49	Cochrane	1907			
		50	Achilles	1907			

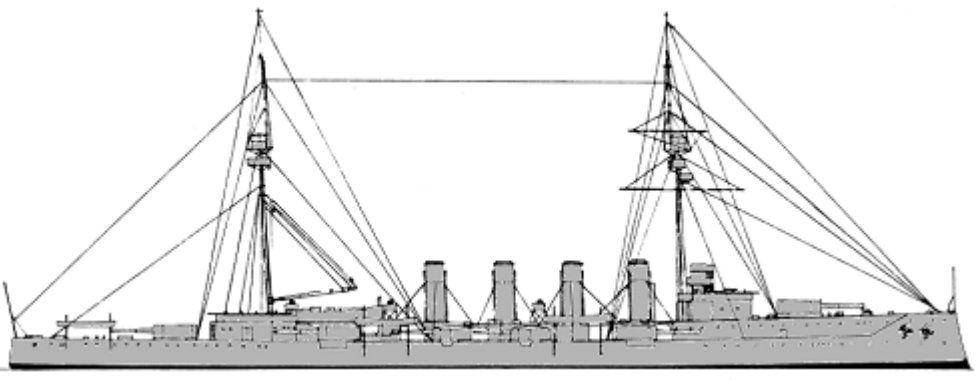
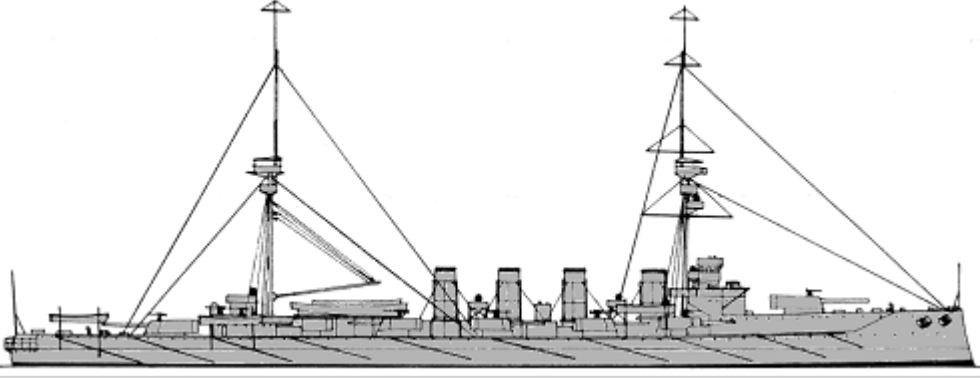
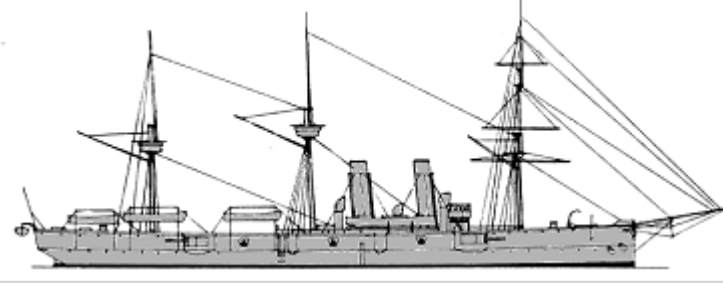
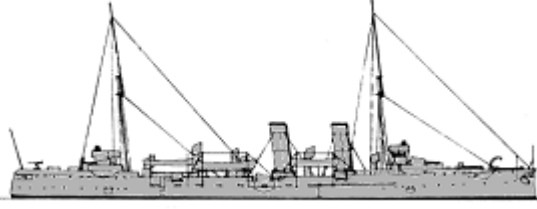
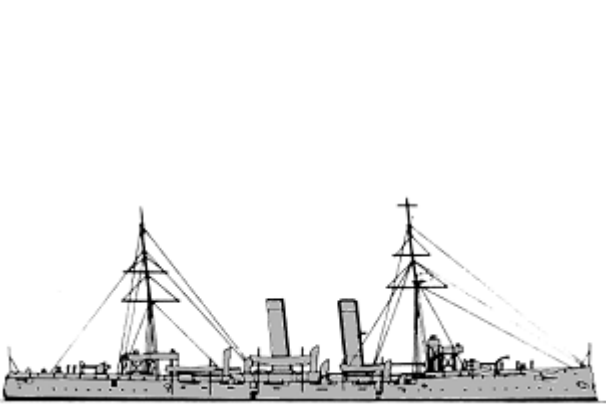



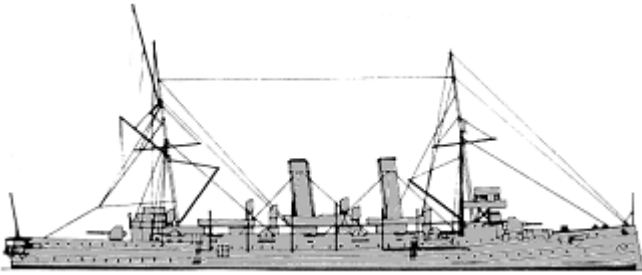
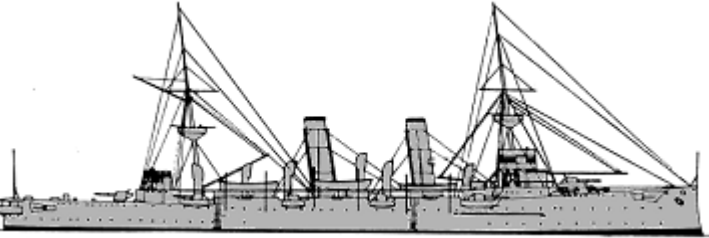
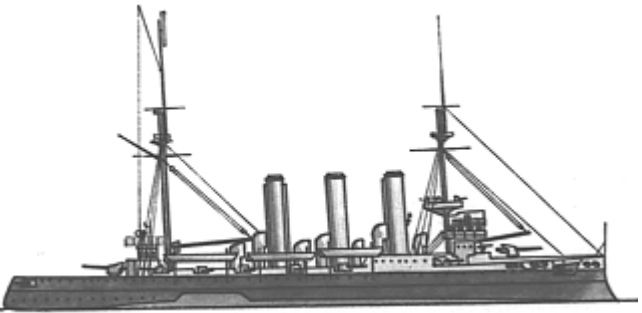
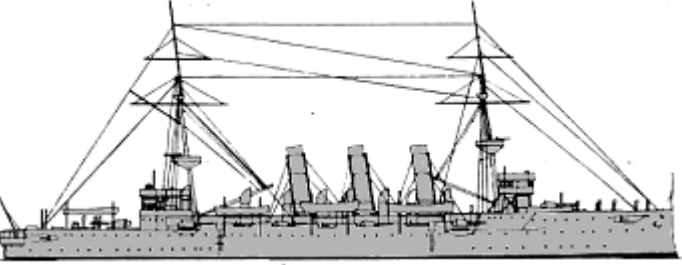

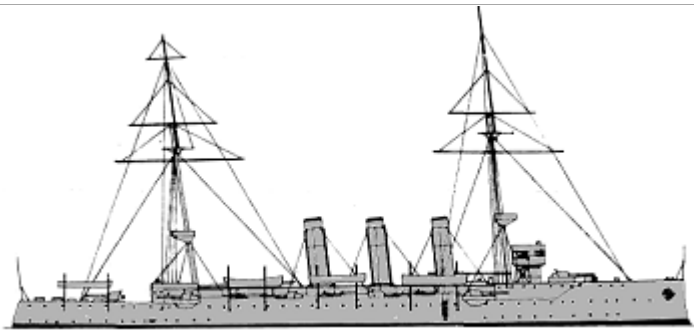
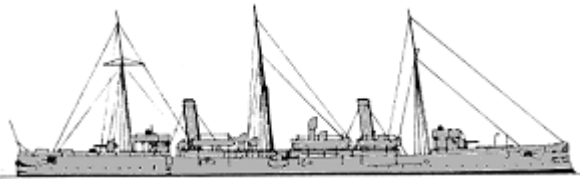
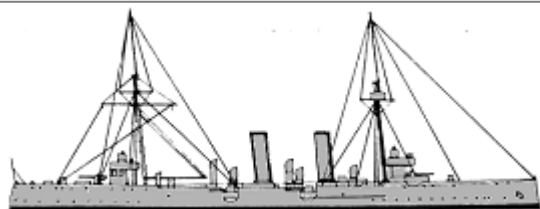
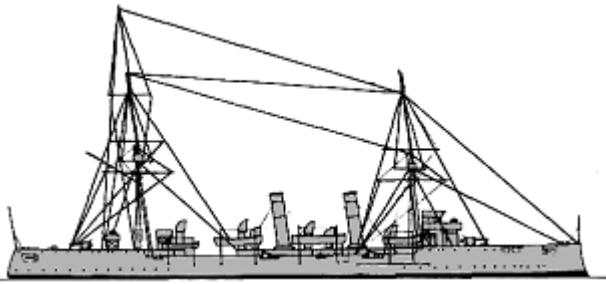
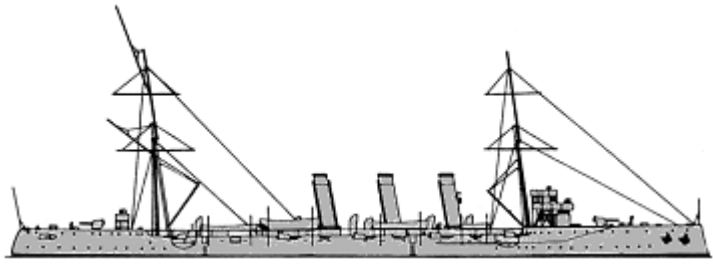

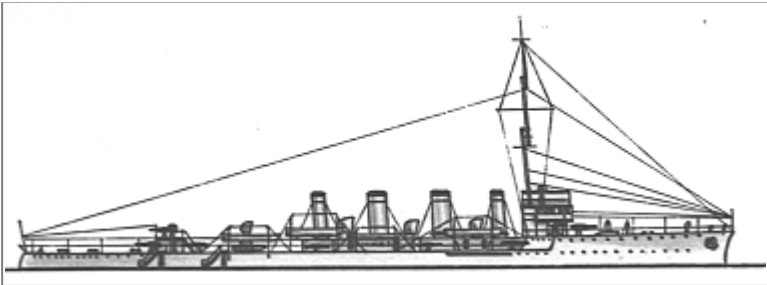
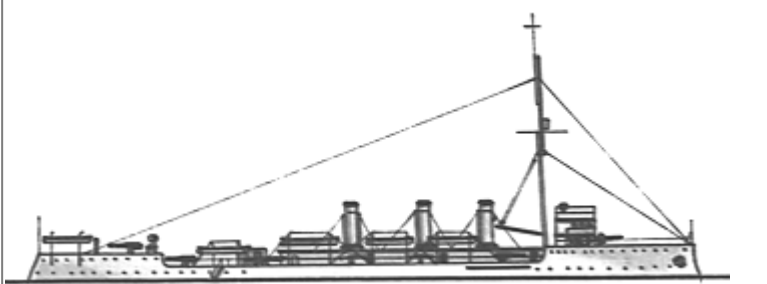
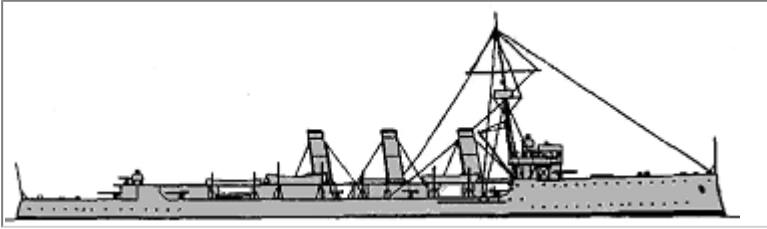
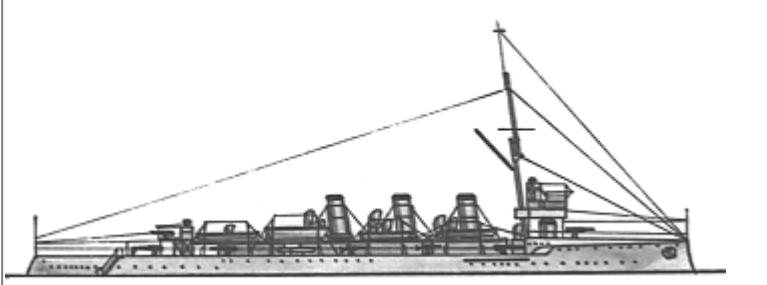
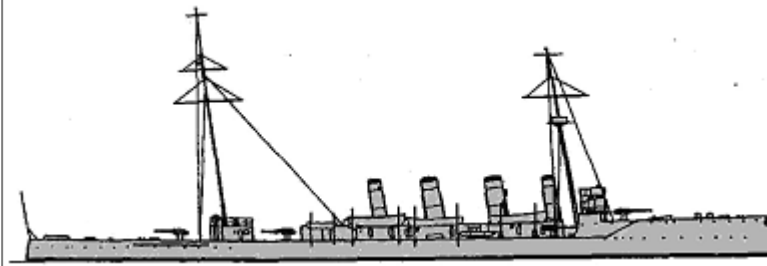
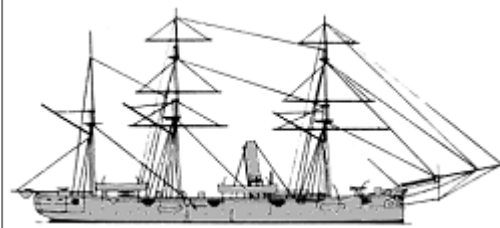
Warrior	4					13550t, 154.0x22.4x7.6m, 25b,2vte, 23000hp, 23kts, 712p; 152belt, 38deck, 190turrets, 254CT; 6x1-234/47, 4x1-190/50, 26x1-47/50, 3-450TT
		51	Natal	1907		
Minotaur	3	52	Minotaur	1908		14600t, 158.2x22.7(52,54)-23.0(53)x7.9m, 24b,2vte, 27000hp, 23kts, 755p; 152belt, 38deck, 203turrets, 254CT; 2x2-234/50, 10x1-190/50, 16x1-76/50, 5-450TT
		53	Shannon	1908		
		54	Defence	1909		
Leander	1	1	Phaeton (TS)	1886		4300t, 96.0x14.0x6.3m, 12b,2hdace, 5500hp, 16.5kts, 278p; steel: 38deck, 38shields; 10x1-152/26, 4x1-47/40, 6x4-25/40, 2x6-11.4, 4x5-11.4, 4-356TC
Medea	2	2	Medea	1889		2800t, 80.8ppx12.5x5.0m, 6b,2vce, 9000hp, 20kts, 218p; steel: 51deck, 114shields, 76CT; 6x1-152/26, 9x1-57/40, 1x1-47/40, 3x1-11.4, (2+2)-356TT/TC
		3	Medusa	1889		
Apollo	14	4	Melampus	1891		3400(4-9)-3600(10-17), 95.7x13.1(4-9)-13.3(10-17)x5.3(4-9)-5.6(10-17), 5b,2vte, 9000hp, 20(4-9)-19.7(10-17), 273p; steel: 51deck, 114shields, 76CT; 2x1-152/40, 6x1-120/40, 8x1-57/40, 1x1-47/40, 4x1-11.4, 4-356TT
		5	Terpsichore	1892		
		6	Naiad	1892		
		7	Tribune	1892		
		8	Sappho	1893		
		9	Scylla	1893		
		10	Sirius	1892		
		11	Pique	1893		
12	Indefatigable	1892				
13	Rainbow	1893				

CL

		14	Intrepid	1892		
		15	Brilliant	1893		
		16	Retribution	1893		
		17	Aeolus	1894		
	Astraea	7	18 Cambrian	1894		4360t, 103.5x15.1x5.8m, 8b,2vte, 9500hp, 19.5kts, 318p; steel: 51deck, 114shields, 76CT; 2x1-152/40, 8x1-120/40, 10x1-57/40, 1x1-47/40, 4-450TT
			19 Astraea	1895		
			20 Charybdis	1896		
			21 Fox	1896		
			22 Hermione	1896		
			23 Flora	1895		
			24 Forte	1895		
	Eclipse	9	25 Eclipse	1897		5600t, 113.7x16.3x6.3m, 8b,2vte, 9600hp, 19.5kts, 450p; Harvey: 76deck, 76shields, 152CT; 5x1-152/40(25), 11x1-152/45(26-33), 6x1-120/40(25), 8x1-76/40, 6x1-47/40, 2x1-11.4, 3-450TT
			26 Talbot	1896		
			27 Venus	1897		
			28 Minerva	1897		
			29 Juno	1897		
			30 Diana	1897		
			31 Doris	1897		
			32 Dido	1898		
			33 Isis	1898		
	Arrogant	3	34 Arrogant	1898		5750t, 104.2x17.5x6.1m, 18b,2vte, 10000hp, 19kts, 480p; Harvey: 76deck, 114shields, 229CT; 10x1-152/45, 8x1-76/40, 3x1-47/40, 5x1-11.4, 3-450TT
			35 Furious	1898		
			36 Vindictive	1900		
	Highflyer	3	37 Hermes	1899		5650t, 113.4x16.5x6.3m, 18b,2vte, 10000hp, 20kts, 450p; Harvey: 76deck, 76shields, 152CT; 11x1-152/40, 9x1-76/40, 6x1-47/40, 2-450TT
			38 Highflyer	1899		
			39 Hyacinth	1900		
	Challenger	2	40 Challenger	1904		5880t, 113.4x16.5x6.3m, 18b,2vte, 12500hp, 21kts, 450p; 76deck, 76shields, 152CT; 11x1-152/45, 9x1-76/40, 6x1-47/40, 2-450TT
			41 Encounter	1905		

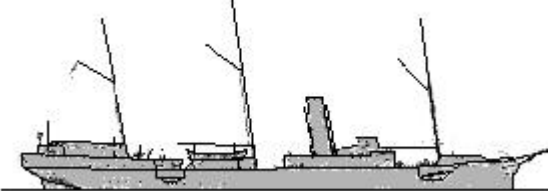







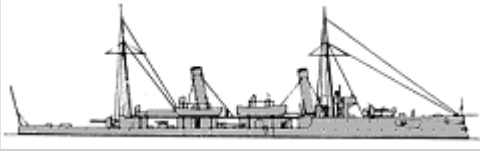
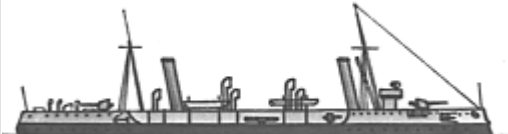

							
	Barham	1	1	Barham	1891		1830t, 85.3ppx10.7x4.0m, 6b,2vte, 4700hp, 18kts, 169p; steel: 51deck, 51shields; 6x1-120/40, 4x1-47/40, 2x1-11.4, 2-356TT
	Pearl	1	2	Philomel	1891		2575t, 84.7x12.5x4.7m, 4b,2vte, 7500hp, 19kts, 217p; steel: 51deck, 51shields, 76CT; 8x1-120/40, 8x1-47/40, 4x1-11.4, (2+2)-356TT/TC
	Pelorus	11	3	Proserpine	1899		2135-2200t, 95.6x11.1x4.9m, 16b,2vte, 7000hp, 20kts, 224p; steel: 51deck, 76shields, 76CT; 8x1-102/40, 8x1-47/40, 3x1-7.7, 2-450TT
			4	Pelorus	1897		
			5	Pactolus	1898		
			6	Pegasus	1898		
			7	Pyramus	1900		
			8	Perseus	1901		
			9	Pomone	1899		
			10	Psyche	1900		
			11	Prometheus	1899		
			12	Pioneer	1900		
	Gem	4	14	Topaze	1904		3000t, 113.9x12.2x4.4m, 10b,2vte(14,16,17)-19b,3st(15), 9800(14,16,17)-12000(15)hp, 21.7(14,16,17)-22.5(15)kts, 296p; 51deck, 25shields, 76CT; 12x1-102/40, 8x1-47/40, 2-450TT
			15	Amethyst	1905		
			16	Diamond	1905		
			17	Sapphire	1905		
CLL	Adventure	2	18	Adventure	1905		120.4x11.7x3.7m, 12b,2vte, 16000hp, 25kts, 268p; 51deck, 76CT; 12x1-76/50, 6x1-57/40, 2-450TT
			19	Attentive	1905		







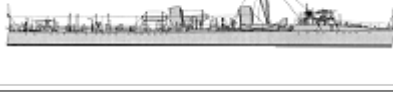
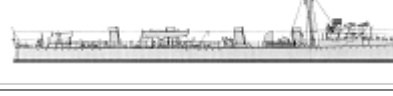

						
Forward	2	20	Forward	1905		2860t, 115.5x12.0x4.3m, 12b,2vte, 16500hp, 25kts, 268p; 51belt, 29deck, 76CT; 12x1-76/50, 6x1-57/40, 2-450TT
		21	Foresight	1905		
Pathfinder	2	22	Pathfinder	1905		2900t, 115.5x11.8x4.0m, 12b,2vte, 16500hp, 25kts, 268p; 51belt, 38deck, 76CT; 12x1-76/50, 6x1-57/40, 2x1-450TT
		23	Patrol	1905		
Sentinel	2	24	Sentinel	1905		2880t, 116.1x12.2x4.3m, 12b,2vte, 17000hp, 25kts, 268p; 38deck, 76CT; 12x1-76/50, 6x1-57/40, 2-450TT
		25	Skirmisher	1905		
Boadicea	1	26	Boadicea	1909		3800t, 123.4x12.5x4.5m, 12b,4st, 18000hp, 25kts, 317p; 25deck, 102CT; 6x1-102/50, 4x1-47/40, 2x1-450TT
Doterel	1	1	President (TS)	1879		1130t, 58.8ppx11.0x4.8m, 3b1hce, 1107hp, 11.5kts, 150p; 2x1-178/16MLR, 2x1-127/25, 6x1-11.4
Alert	1	2	Torch	1895		960t, 62.4x9.9x3.5m, 4b1vte, 1400hp, 13.2kts, 105p; 38deck; 6x1-102/40,



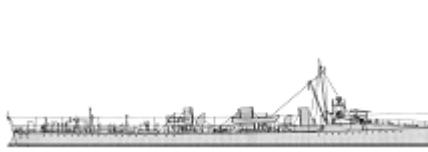

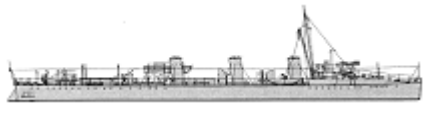

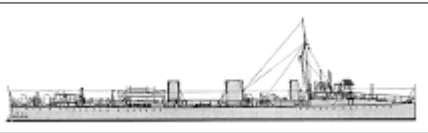

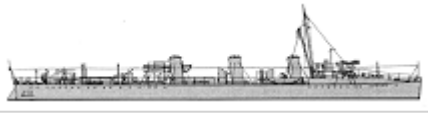
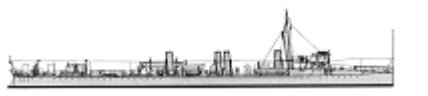

SL						4x1-47/40, 2x1-11.4	
	Phoenix	1	3	Algerine	1896		1050t, 62.4x9.9x4.2m, 4b,1vte, 1400hp, 13kts, 106p; 6x1-102/40, 4x1-47/40, 3x1-11.4
	Condor	4	4	Rosario	1899		980t, 62.2x9.9x3.5m, 4b,2vte, 1400hp, 13.5kts, 130p; steel: 38deck, 6shields; 6x1-102/40, 4x1-47/40, 3x1-11.4
			5	Shearwater	1900		
			6	Vestal	1900		
7			Rinaldo	1900			
Espiegle	4	8	Espiegle	1901		1070t, 64.1x10.1x3.4m, 4b,2vte, 1400hp, 13.2kts, 135p; 38deck, 6shields; 6x1-102/40, 4x1-47/40, 3x1-11.4	
		9	Odin	1902			
		10	Clio	1904			
		11	Cadmus	1904			
DV	Surprise	2	1	Surprise	1886		1650-1700t, 83.9x9.9x4.0m, 4b,2hdace, 3030hp, 17kts, 93p; steel: 10deck; 4x1-127/25(1), 4x1-57/40(1), 10x1-57/40(2), 2x1-11.4(1)
			2	Alacrity	1886		
	Havock	1	3	Havock	1894		275t, 56.4x5.7x2.2m, 3b,2vte, 3800hp, 26kts, 46p; 1x1-76/40, 5x1-57/40
	Daring	1	4	Daring	1895		288t, 56.4x5.8x2.1m, 3b,2vce, 3200hp, 27kts, 48p; 1x1-76/40, 5x1-57/40
Ferret	1	5	Lynx	1895		280t, 60.1x6.0x2.7m, 4b,2vte, 4475hp, 27.2kts, 46p; 1x1-76/40, 5x1-57/40	

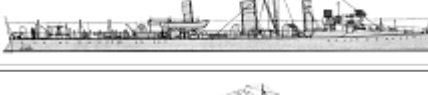







TORPEDO SHIPS





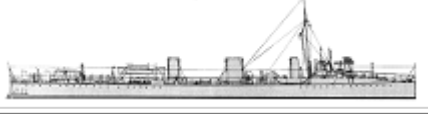



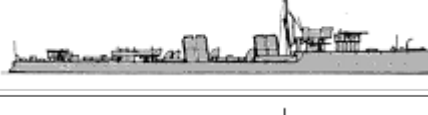
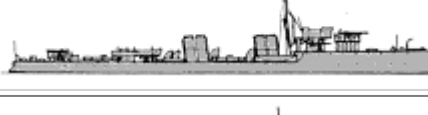
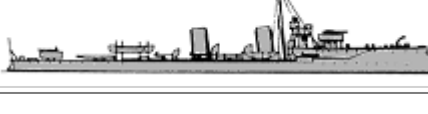

PGT	Alarm	1	1	Antelope	1894		810t, 70.1ppx8.2x3.7m, 4b,3vte, 3500hp, 18.7kts, 91p; 2x1-120/40, 4x1-47/40, 1x5-11.4, (1+2x2)-356TT
	Dryad	4	2	Dryad	1894		1070t, 80.1x9.3x3.5m, 4b,2vte, 6000hp, 20kts, 120p; 2x1-120/40, 4x1-57/40, 1x5-11.4, (1+4x1)-450TT
			3	Harrier	1895		
			4	Halcyon	1895		





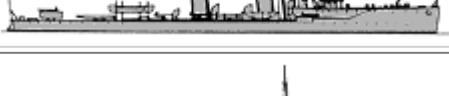



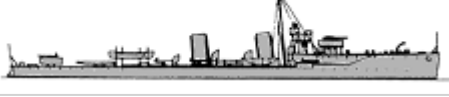
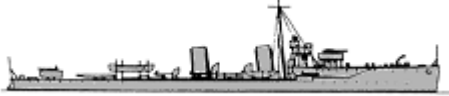



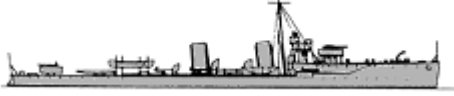



		5	Hussar	1895		
Ardent	3	1	Ardent	1895		295t, 61.5x5.8x2.2m, 3b,2vte, 4500(1,3)-4200(2)hp, 28(1)-29(2)-30(3)kts, 53p; 1x1-76/40, 5x1-57/40, 2x1-450TT
		2	Boxer	1895		
		3	Bruizer	1895		
Janus	3	4	Janus	1895		320t, 61.1x5.9x2.4m, 4b,2vte, 3900hp, 28kts, 54p; 1x1-76/40, 5x1-57/40, 2x1-450TT
		5	Lightning	1896		
		6	Porcupine	1896		
Banshee	3	7	Banshee	1895		345t, 64.9x5.9x2.9m, 4b,2vte, 4400hp, 28kts, 58p; 1x1-76/40, 5x1-57/40, 2x1-450TT
		8	Contest	1895		
		9	Dragon	1895		
Handy	3	10	Handy	1895		310t, 60.1x5.9x2.3m, 3b,2vte, 4000hp, 27kts, 55p; 1x1-76/40, 5x1-57/40, 2x1-450TT
		11	Hart	1896		
		12	Hunter	1896		
Rocket	3	13	Rocket	1895		325t, 62.2x6.0x2.21m, 4b,2vte, 4100hp, 27kts, 58p; 1x1-76/40, 5x1-57/40, 1x1-450TT(13,15), 2x1-450TT(14)
		14	Shark	1895		
		15	Surly	1895		
Charger	3	16	Charger	1896		295t, 59.4x5.6x2.2m, 4b,2vte, 3100(16,17)-3800(18)hp, 26.2kts, 53p; 1x1-76/40, 5x1-57/40, 2x1-450TT
		17	Hasty	1896		
		18	Dasher	1896		
Haughty	2	19	Haughty	1896		325t, 61.0x5.9x2.4m, 8b,2vte, 4200hp, 27kts, 54p; 1x1-76/40, 5x1-57/40, 2x1-450TT
		20	Hardy	1896		
Salmon	2	21	Salmon	1896		340t, 61.5x6.0x2.4m, 8b,2vte, 3700hp, 27kts, 52p; 1x1-76/40, 5x1-57/40, 2x1-450TT
		22	Snapper	1896		
Sunfish	3	23	Sunfish	1896		340t, 62.2x5.8x2.6m, 8b,2vte, 4000hp, 27kts, 58p; 1x1-76/40, 5x1-57/40, 2x1-450TT
		24	Opossum	1896		
		25	Ranger	1896		
Sturgeon	2	26	Sturgeon	1896		340t, 59.3x5.8x2.3m, 4b,2vte, 4000hp, 27.8kts, 52p; 1x1-76/40, 5x1-57/40, 2x1-450TT
		27	Starfish	1896		
Swordfish	2	28	Swordfish	1896		355t, 62.3x5.8x2.4m, 8b,2vte, 4500hp, 27kts, 58p; 1x1-76/40, 5x1-57/40, 2x1-450TT
		29	Spitfire	1896		
Desperate	4	30	Desperate	1897		350t, 64.0x6.0x2.1m, 3b,2vte, 5700hp, 30kts, 54p; 1x1-76/40, 5x1-57/40, 2x1-450TT
		31	Fame	1897		
		32	Foam	1897		
		33	Mallard	1897		
Quail	3	34	Quail	1897		415t, 66.5x6.6x2.9m, 4b,2vte, 6300hp, 30kts, 56p; 1x1-76/40, 5x1-57/40, 2x1-450TT
		35	Thrasher	1897		
		36	Virago	1897		
		37	Avon	1899		







Avon	3	38	Bittern	1897		405t, 65.3x6.1x2.5m, 4b,2vte, 6300hp, 30kts, 60p; 1x1-76/40, 5x1-57/40, 2x1-450TT
		39	Otter	1900		
Earnest	6	40	Earnest	1897		415t, 66.5x6.6x3.0m, 4b,2vte, 6300hp, 30kts, 56p; 1x1-76/40, 5x1-57/40, 2x1-450TT
		41	Griffon	1897		
		42	Locust	1898		
		43	Panther	1898		
		44	Seal	1898		
Star	5	45	Wolf	1898		440t, 67.1x6.4x3.0m, 4b,2vte, 6200hp, 30kts, 58p; 1x1-76/40, 5x1-57/40, 2x1-450TT
		46	Star	1898		
		47	Whiting	1897		
		48	Bat	1897		
		49	Crane	1898		
Angler	1	50	Flying Fish	1898		352t, 64.0x6.0x2.1m, 3b,2vte, 5700hp, 30kts, 54p; 1x1-76/40, 5x1-57/40, 2x1-450TT
		51	Angler	1898		
Violet	2	52	Violet	1898		400t, 65.2(52)-65.5(53)x6.4x2.9m, 4b,2vte, 6300hp, 30kts, 58p; 1x1-76/40, 5x1-57/40, 2x1-450TT
		53	Sylvia	1899		
Gipsy	3	54	Gipsy	1898		400t, 65.7x6.5x2.5m, 4b,2vte, 6300hp, 30kts, 60p; 1x1-76/40, 5x1-57/40, 2x1-450TT
		55	Osprey	1898		
		56	Fairy	1898		
Fawn	2	57	Fawn	1898		440t, 67.1x6.4x3.0m, 4b,2vte, 6200hp, 30kts, 58p; 1x1-76/40, 5x1-57/40, 2x1-450TT
		58	Flirt	1899		
Conflict	3	59	Conflict	1899		360t, 62.7x6.1x2.5m, 3b,2vte, 4500hp, 27kts, 54p; 1x1-76/40, 5x1-57/40, 2x1-450TT
		60	Teazer	1899		
		61	Wizard	1899		
Cheerful	2	62	Cheerful	1900		400t, 65.5x6.4x2.5m, 4b,2vte, 6100hp, 30kts, 58p; 1x1-76/40, 5x1-57/40, 2x1-450TT
		63	Mermaid	1899		
Coquette	3	64	Coquette	1899		367t, 64.0x6.0x2.3m, 3b,2vte, 5700hp, 30kts, 54p; 1x1-76/40, 5x1-57/40, 2x1-450TT
		65	Cynthia	1899		
		66	Cygnnet	1900		
Leopard	1	67	Leopard	1899		400t, 65.3x6.1x2.5m, 4b,2vte, 6300hp, 30kts, 60p; 1x1-76/40, 5x1-57/40, 2x1-450TT
						420t, 65.7x6.5x2.5m, 4b,2vte, 6100hp, 30kts, 58p; 1x1-76/40, 5x1-57/40, 2x1-

DD	Leven	1	68	Leven	1899		450TT
	Fervent	2	69	Fervent	1900		320t, 62.4x5.8x2.2m, 2b,2vte, 4000hp, 26kts, 48p; 1x1-76/40, 5x1-57/40, 2x1-450TT
			70	Zephyr	1901		
	Zebra	1	71	Zebra	1900		365t, 62.4x5.8x2.3m, 3b,2vte, 4800hp, 27kts, 54p; 1x1-76/40, 5x1-57/40, 2x1-450TT
	Brazen	4	72	Brazen	1900		425(72-74)-385(75)t, 65.2(72,73)-66.5(74)-67.8(75)x6.1x2.5m, 4b,2vte, 5800hp, 30.5kts, 60p; 1x1-76/40, 5x1-57/40, 2x1-450TT
			73	Electra	1900		
			74	Recruit	1900		
			75	Vulture	1900		
	Kestrel	1	76	Kestrel	1900		395t, 67.8x6.3x2.7m. 4b,2vte, 5800hp, 30kts, 58p; 1x1-76/40, 5x1-57/40, 2x1-450TT
	Spiteful	2	77	Spiteful	1900		450(77)-420(78)t, 67.1(77)-66.9(78)x6.4x2.7m, 4b,2vte, 6200hp, 30kts, 58p; 1x1-76/40, 5x1-57/40, 2x1-450TT
			78	Peterel	1900		
	Orwell	1	79	Orwell	1900		410t, 66.0x6.6x2.9m, 4b,2vte, 6300hp, 30kts, 56p; 1x1-76/40, 5x1-57/40, 2x1-450TT
	Stag	1	80	Stag	1900		371t, 64.0x6.0x2.2m, 3b,2vte, 5800hp, 30kts, 63p; 1x1-76/40, 5x1-57/40, 2x1-450TT
	Albatross	1	81	Albatross	1900		490t, 69.2x6.5x2.8m, 4b,2vte, 7500hp, 31.5kts, 69p; 1x1-76/40, 5x1-57/40, 2x1-450TT
	Taku	1	82	Taku	1898		305t, 59.1x6.4x2.0m, 4b,2vte, 6000hp, 30kts, 58p; 6x1-47/35, 2x1-356TT
	Bullfinch	2	83	Bullfinch	1901		390t, 65.4x6.3x2.4m, 4b,2vte, 5800hp, 30kts, 58p; 1x1-76/40, 5x1-57/40, 2x1-450TT
84			Dove	1901			
Myrmidon	2	85	Myrmidon	1901		420(85)-440(86)t, 67.0-67.1x6.4x2.7-2.8m, 4b,2vte, 6300hp, 56p; 1x1-76/40, 5x1-57/40, 2x1-450TT	
		86	Syren	1902			
Falcon	2	87	Falcon	1901		420t, 65.7(87)-65.4(88)x6.5x2.7m, 4b,2vte, 6100hp, 30kts, 58p; 1x1-76/40, 5x1-57/40, 2x1-450TT	
		88	Ostrich	1901			

						
Thorn	2	89	Thorn	1901		425t, 67.7x6.3x2.7m, 4b,2vte, 6400hp, 30kts, 60p; 1x1-76/40, 5x1-57/40, 2x1-450TT
		90	Vigilant	1901		
Kangaroo	1	91	Kangaroo	1901		420t, 67.0x6.4x2.7m, 4b,2vte, 6100hp, 30kts, 56p; 1x1-76/40, 5x1-57/40, 2x1-450TT
Greyhound	3	92	Greyhound	1902		430t, 65.4x6.4x4.0m, 4b,2vte, 6100hp, 30kts, 58p; 1x1-76/40, 5x1-57/40, 2x1-450TT
		93	Racehorse	1902		
		94	Roebuck	1902		
Success	1	95	Success	1902		420t, 65.5x6.4x2.7m, 4b,2vte, 6300hp, 30kts, 58p; 1x1-76/40, 5x1-57/40, 2x1-450TT
Vixen	1	96	Vixen	1902		445t, 65.7x6.5x2.5m, 4b,2vte, 6300hp, 30kts, 58p; 1x1-76/40, 5x1-57/40, 2x1-450TT
Lively	2	97	Lively	1902		435t, 66.8x6.7x2.6m, 4b,2vte, 6250hp, 30kts, 56p; 1x1-76/40, 5x1-57/40, 2x1-450TT
		98	Sprightly	1902		
Express	1	99	Express	1902		540t, 73.0x7.2x3.1m, 4b,2vte, 9250hp, 31kts, 74p; 1x1-76/40, 5x1-57/40, 2x1-450TT
Arab	1	100	Arab	1903		530t, 70.7x6.8x3.0m, 4b,2vte, 8600hp, 30.7kts, 69p; 1x1-76/40, 5x1-57/40, 2x1-450TT
Velox	1	101	Velox	1904		445t, 65.5x6.0x2.7m, 4b,4st/st(2), 8000/200hp, 30kts, 63p; 1x1-76/40, 5x1-57/40, 2x1-450TT
Erne	3	102	Erne	1904		620t, 71.2x7.2x3.0m, 4b,2vte, 7000hp, 25.5kts, 70p; 1x1-76/40, 3x1-76/28, 2x1-450TT
		103	Etrick	1904		
		104	Exe	1904		
Usk	3	105	Usk	1904		660t, 70.5x7.2x3.1m, 4b,2vte, 7500hp, 26kts, 70p; 1x1-76/40, 3x1-76/28, 2x1-450TT
		106	Teviot	1904		
		107	Ribble	1904		
Derwent	2	108	Derwent	1904		620t, 68.7x7.2x2.7m, 4b,2vte(108)-4b,3st(109), 7000hp, 25.6(108)-26.2(109)kts, 70p; 1x1-76/40, 3x1-76/28, 2x1-450TT
		109	Eden	1904		
Foyle	2	110	Foyle	1904		625t, 69.1x7.2x2.9m, 4b,2vte, 7000hp, 25.6kts, 70p; 1x1-76/40, 3x1-76/28, 2x1-450TT
		111	Itchen	1904		



						
Welland	1	112	Welland	1904		660t, 70.5x7.2x3.1m, 4b,2vte, 7500hp, 26kts, 70p; 1x1-76/40, 3x1-76/28, 2x1-450TT
Cherwell	2	113	Cherwell	1904		615(113)-620(114)t, 70.1x7.2x3.0m, 4b,2vte, 7000hp, 25.5kts, 70p; 1x1-76/40, 3x1-76/28, 2x1-450TT
		114	Dee	1904		
Arun	1	115	Arun	1904		625t, 69.1x7.2x2.9m, 4b,2vte, 7000hp, 25.6kts, 70p; 1x1-76/40, 3x1-76/28, 2x1-450TT
Waveney	1	116	Waveney	1904		620t, 68.7x7.2x2.7m, 4b,2vte, 7000hp, 25.6kts, 70p; 1x1-76/40, 3x1-76/28, 2x1-450TT
Kennet	2	117	Kennet	1905		615t, 68.6x7.3x2.8m, 4b,2vte, 7500hp, 25.8kts, 70p; 1x1-76/40, 3x1-76/28, 2x1-450TT
		118	Jed	1905		
Chelmer	2	119	Chelmer	1905		615t, 68.6x7.3x2.8m, 4b,2vte, 7500hp, 25.8kts, 70p; 1x1-76/40, 3x1-76/28, 2x1-450TT
		120	Colne	1905		
Gala	1	121	Garry	1905		660t, 70.5x7.2x3.1m, 4b,2vte, 7500hp, 26.5kts, 70p; 1x1-76/40, 3x1-76/28, 2x1-450TT
Ness	2	122	Ness	1905		630t, 70.0x7.3x2.9m, 4b,2vte, 7500hp, 25.6kts, 70p; 1x1-76/40, 3x1-76/28, 2x1-450TT
		123	Nith	1905		
Ure	3	124	Ure	1905		620t, 70.1x7.3x2.8m, 4b,2vte, 7000hp, 25.6kts, 70p; 1x1-76/40, 3x1-76/28, 2x1-450TT
		125	Wear	1905		
		126	Swale	1905		
Liffey	3	127	Liffey	1905		625t, 69.1x7.2x2.9m, 4b,2vte, 7000hp, 25.5kts, 70p; 1x1-76/40, 3x1-76/28, 2x1-450TT
		128	Moy	1905		
		129	Ouse	1905		
Boyne	3	130	Boyne	1905		615t, 68.7x7.2x2.7m, 4b,2vte, 7000hp, 25.7kts, 70p; 1x1-76/40, 3x1-76/28, 2x1-450TT
		131	Doon	1905		
		132	Kale	1905		
Rother	1	133	Rother	1905		662t, 70.1x7.2x2.8m, 4b,2vte, 7000hp, 25.5kts, 70p; 1x1-76/40, 3x1-76/28, 2x1-450TT
		134	Cossack	1908		
		135	Mohawk	1908		

Tribal-1	5	136	Ghurka	1908		1000t, 78.2-84.5x7.5-7.8x3.1m, 5b,3st(134,136,137)-6b,3st(135,138), 14000hp, 33kts, 68p; 5x1-76/40, 2x1-450TT
		137	Afridi	1909		
		138	Tartar	1908		
Tribal-2	5	139	Saracen	1909		1200t, 85.0-87.6x8.0-8.4x3.1m, 6b,3st, 14000hp, 33kts, 68p; 2x1-102/40, 2x1-450TT
		140	Amazon	1909		
		141	Crusader	1909		
		142	Nubian	1909		
		143	Maori	1909		
Albacore	2	144	Albacore	1909		550t, 65.7x6.5x2.2m, 4b,2st, 7000hp, 26.5kts, 56p; 3x1-76/40, 2x1-450TT
		145	Bonetta	1909		
Stour	2	146	Stour	1909		620t, 69.1x7.2x2.7m, 4b,2st, 7000hp, 25.5kts, 70p; 1x1-76/40, 3x1-76/28, 2x1-450TT
		147	Test	1909		
TB81	1	1	TB081	1885		137t, 46.9x5.3x2.9m, 2b,1vce, 1330hp, 23.7kts, 25p; 4x1-47/40, (1+2x1)-356TT
TB25	1	2	TB025	1886		60t, 39.1x3.8x1.8m, 1b,1hce, 591hp, 19.4kts, 16p; 3x2-25/40, 2x2-356TT
TB26	21	3 - 23	TB026, 027, 029, 041-046, 048-055, 057-060	1886 - 1887		60t, 38.9x3.8x2.5m, 1b,1hce, 700-750hp, 19.5-21.5kts, 16p; 3x2-25/40, 2x2-356TT
TB30	16	24 - 39	TB031, 033, 063-068, 070-074, 076-078	1886 - 1887		60t, 38.2x4.0x2.5m, 1b,1hce, 670hp, 19.5kts, 16p; 2x1-25/40, (1+2x2)-356TT
TB34	5	40 - 44	TB034-038	1886 - 1887		60(40-43)-66(44,45)t, 38.1pp(40-43)-40.3pp(44,45)x4.4x1.3m, 1b,1hce, 950hp, 18-19kts, 16p; 2x1-47/40(44,45), 2x1-25/40(40-43), (1+2x2)-356TT
TB79	1	45	TB079	1886		75t, 39.2x4.0x1.7m, 1b,1vte, 1000hp, 22.2kts, 16p; 2x1-47/40, (2+1x1)-356TT
TB80	1	46	TB080	1887		105t, 41.2ppx4.3x1.8m, 2b,1vte, 1539hp, 23kts, 21p; 3x1-47/40, (1+1x2)-356TT
Gurkha	1	47	TB101	1888		92t, 41.2x4.3x2.1m, 2b,1hce, 1000hp, 21.5kts, 18p; 2x2-25/40, (1+2x2)-356TT
Mahratta	3	48 - 50	TB104 - 106	1889		95t, 41.2x4.4x2.3m, 2b,1hce, 1000hp, 22kts, 18p; 2x2-25/40, (1+2x2)-356TT
TB82	5	51 - 55	TB082, 083, 085-087	1889		85t, 39.7ppx4.1x1.8m, 1b,1vte, 1800hp, 23kts, 19p; 3x1-47/40, (1+1x2)-356TT
TB88	2	56	TB088	1894		112t, 43.3ppx4.5x2.3m, 1b,1vte, 1850hp, 23.5kts, 18p; 3x1-47/40, (1+1x2)-450TT
		57	TB089	1894		
TB91	2	58	TB091	1894		141t, 43.3(79)-42.8(80)x4.7x2.3m, 1b,1vte, 2350hp, 24.5kts, 18p; 3x1-47/40, (1+1x2)-450TT
		59	TB092	1894		
TB93	1	60	TB093	1894		136t, 42.8x4.7x1.6m, 2b,2vte, 2200hp, 23.5kts, 18p; 3x1-47/40, (1+1x2)-450TT
TB94	3	61	TB094	1894		130t, 43.4ppx4.7x2.7m, 2b,2vte, 2000hp, 23kts, 18p; 3x1-47/40, (1+1x2)-450TT
		62	TB095	1895		
		63	TB096	1895		

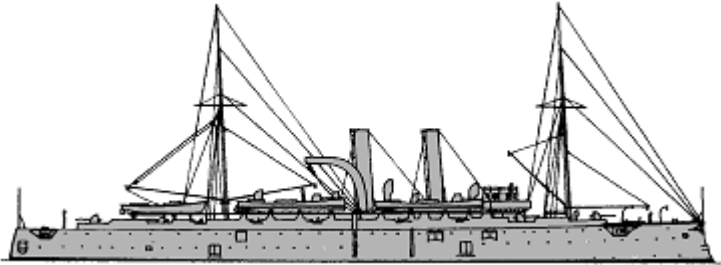
TB	TB97	1	64	TB097	1894		130t, 42.8ppx4.9x2.3m, 2b,2vte, 2000hp, 23kts, 18p; 3x1-47/40, (1+1x2)-450TT
	TB90	1	65	TB090	1895		112t, 42.8ppx4.4x2.0m, 1b,1vte, 1500hp, 23kts, 18p; 3x1-47/40, (1+1x2)-450TT
	TB98	4	66	TB098	1901		185t, 50.0x5.2x1.8m, 2b,2vte, 3000hp, 25kts, 32p; 3x1-47/40, 3x1-450TT
			67	TB099	1901		
			68	TB107	1901		
			69	TB108	1901		
	TB109	5	70	TB109	1902		200t, 50.6x5.3x1.7m, 2b,2vte, 3050hp, 25kts, 32p; 3x1-47/40, 3x1-450TT
			71	TB110	1902		
			72	TB111	1902		
			73	TB112	1903		
74			TB113	1903			
TB114	4	75	TB114	1904		219t, 50.3ppx5.3x2.6m, 2b,2vte, 3050hp, 25kts, 32p; 3x1-47/40, 3x1-450TT	
		76	TB115	1904			
		77	TB116	1904			
		78	TB117	1905			
Cricket	36	79	TB1	1906		400t, 53.3(79-90)-56.4(91-114)x5.3(79-90)-5.5(91-114)x1.8(79-90)-2.0(91-114)m, 2b,3st, 3750(79-90)-4000(91-114)hp, 26.5(79-90)-26(91-114)kts, 35p; 2x1-76/40, 3x1-450TT	
		80	TB2	1907			
		81	TB3	1907			
		82	TB4	1907			
		83	TB5	1907			
		84	TB6	1906			
		85	TB7	1907			
		86	TB8	1907			
		87	TB9	1907			
		88	TB10	1907			
		89	TB11	1907			
		90	TB12	1907			
		91	TB13	1908			
		92	TB14	1908			
93	TB15	1908					
94	TB16	1908					
95	TB17	1908					
96	TB18	1908					
97	TB19	1908					
98	TB20	1908					
99	TB21	1909					
100	TB22	1909					
101	TB23	1908					
102	TB24	1909					

			103	TB25	1909		
			104	TB26	1909		
			105	TB27	1909		
			106	TB28	1909		
			107	TB29	1908		
			108	TB30	1908		
			109	TB31	1909		
			110	TB32	1909		
			111	TB33	1909		
			112	TB34	1909		
			113	TB35	1909		
			114	TB36	1909		
TB2cl	TB76	1	1	TB95	1883	No picture	13t, 19.5x2.3x1.1m, 1b,1hce, 170hp, 16.5kts, 7p; 2-356TT
	WTB1	3	2 - 4	WTB9, 11, 12	1885 - 1888	No picture	11-14t, 17.1x2.8x1.5m, 1b,1hce, 140-200hp, 16kts, 9p; (1-2)x1-11.4, 1-356TT or 2-356TC or 1x1-356TT
	TB39	4	5 - 8	TB45 - 48	1889		17t, 18.3ppx2.8xm, 1b,1vte, 240hp, 16.5kts, 9p; 1x1-25/40, 2-356TC
CTB	Hecla	1	1	Hecla	1879	No picture	6400t, 119.6ppx11.8x6.9m, b,2hice, 1758hp, 12.1kts, 277p; 4x1-160/16MLR, 1x1-127/25, 1x1-121/21, 4 TB2cl
	Vulcan	1	2	Vulcan	1891		6620t, 113.7x17.7x6.7m, 5b,2vte, 12000hp, 20kts, 432p; steel: 127deck, 152CT; 8x1-120/40, 12x1-47/40, 12x1-11.4, 6TT, 9 TB2cl

SUBMARINES

Holland	5	1	No1	1903		110/122t, 19.5x3.6x3.0m, 1pe/em, 160/74hp, 8/7kts, 8p, 30m; 1-356TT
		2	No2	1902		
		3	No3	1902		
		4	No4	1903		
		5	No5	1903		
A	12	6	A2	1904		165/180(6-8)-180/207(9-17)t, 30.5(6-8)-30.2(9-17)x3.5(6-8)-3.9(9-17)x3.1m, 1pe/em(6-16), 1d/em(17), 450/80(6-8)-550/150(9-16)-400/150(17)hp, 11.5/7(6-8)-12/8(9-16)-11/8(17)kts, 11(6-8)-13(9-17)p, 30m; 2-450TT
		7	A3	1904		
		8	A4	1904		
		9	A5	1905		
		10	A6	1905		
		11	A7	1905		
		12	A8	1905		
		13	A9	1905		





		14	A10	1905		
		15	A11	1905		
		16	A12	1905		
		17	A13	1908		
B	11	18	B1	1904		287/316t, 43.3x4.1x3.4m, 1pe/em, 600/290hp, 12/6kts, 15p, 30m; 2-450TT
		19	B2	1905		
		20	B3	1906		
		21	B4	1906		
		22	B5	1906		
		23	B6	1906		
		24	B7	1906		
		25	B8	1906		
		26	B9	1906		
		27	B10	1906		
		28	B11	1906		
SS	C	29	C1	1906		290/320t, 43.4x4.1x3.5m, 1pe/em, 600/300hp, 13/7.5kts, 16p, 30m; 2-450TT
		30	C2	1906		
		31	C3	1907		
		32	C4	1907		
		33	C5	1907		
		34	C6	1907		
		35	C7	1907		
		36	C8	1907		
		37	C9	1907		
		38	C10	1907		
		39	C12	1908		
		40	C13	1908		
		41	C14	1908		
		42	C15	1908		
		43	C16	1908		
		44	C17	1909		
		45	C18	1909		
		46	C19	1909		
47	C21	1909				
48	C22	1909				
49	C23	1909				
50	C24	1909				
51	C25	1909				
52	C26	1909				
53	C27	1909				
54	C28	1909				



			55	C29	1909		
			56	C30	1909		
			57	C31	1909		
			58	C32	1909		
D	1	59	D1	1909		483/595t, 49.7x6.1x3.2m, 2d/em, 1200/550hp, 14/9kts, 25p, 30m; 3-450TT	

ESCORTS

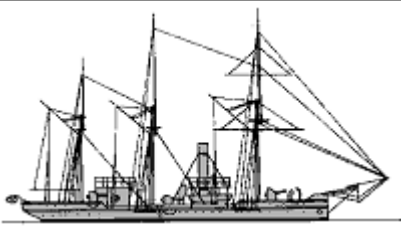

AFPV	-	3	1	Julia	1897	310t
			2	Argus	1904	380t
			3	Squirrel	1904	230t

OTHER FIGHTING SHIPS

PG	Ant	6	1	Bustard	1871		254t, 25.9x8.0x1.8-2.0m, 1b,2hse(t), 260hp, 8.5kts, 30p; 1x1-254MLR
			2	Kite	1871		
			3	Mastiff	1871		
			4	Arrow	1871		
			5	Ant	1873		
			6	Cuckoo	1873		
	Medina	4	7	Sabrina	1876		363t, 33.5x10.4x1.8m, 1b,2hse, 310hp, 9.5kts, 51p; 3x1-160/16MLR
			8	Spey	1876		
			9	Tay	1876		
			10	Don	1877		
	Bouncer	1	11	Insolent	1881		265t, 26.6x8.0x2.0m, 1b,2hse, 230hp, 8.5kts, 30p; 1x1-254/15MLR
	Handy	1	12	Excellent	1883	No picture	508t, 35.1x11.3x2.8m, 2b,2hse, 310hp, 8.5kts; 1x1-190/45, 1x1-102/40
	Bramble	1	13	Rattler	1887	No picture	810t, 50.3ppx8.8x3.4m, 2b,1vte, 1200hp, 13kts, 76p; 6x1-102/40, 4x1-11.4
	Redbreast	3	14	Lapwing	1889		805t, 50.3ppx9.5x3.4m, 2b,1vte, 1200hp, 13kts, 76p; 6x1-102/27(15,16), 6x1-102/28(14), 4x1-11.4
			15	Redbreast	1889		
			16	Ringdove	1890		
	Bramble	4	17	Bramble	1900		710t, 57.2x10.1x2.4m, 4b,2vte, 1300hp, 13.5kts, 85p; 2x1-102/40, 4x1-76/40, 10x1-11.4
			18	Britomart	1900		
			19	Dwarf	1899		
			20	Thistle	1901		
Heron	4	1-4	Nightingale, Robin, Sandpiper, Snipe	1898	No picture	85t, 32.8x6.1x0.6m, 1b,1vte, 240hp, 9kts, 25p; 2x1-57/40	
		5	Woodcock	1898			

PGR	Woodcock	2	6	Woodlark	1898	No picture	150t, 44.2x7.3x0.6m, 1b,1vte, 550hp, 13kts, 25p; 2x1-57/40, 4x1-7.9
	Teal	2	7	Teal	1901		180t, 48.7x7.5x0.8m, 1b,1vte, 670hp, 13kts, 35p; 2x1-57/40, 4x1-7.9
			8	Moorhen	1901		
	Widgeon	1	9	Widgeon	1904		195t, 48.7x7.5x1.0m, 1b,1vte, 800hp, 12.5kts, 35p; 2x1-57/40
APGR	-	1	1	Kinsha	1900		616t; 2-76/40

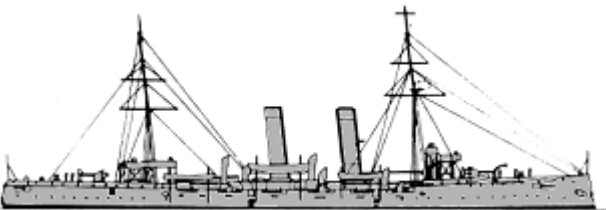
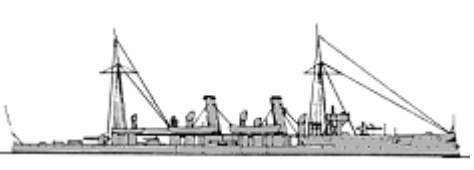
MINE WARFARE SHIPS

ML	Apollo	5	1	Latona	1891		3400(1-4)-3600(5), 95.7x13.1(1-4)-13.3(5)x5.3(1-4)-5.6(5), 5b,2vte, 9000hp, 20(1-4)-19.7(5), 273p; steel: 51deck, 114shields, 76CT; 2x1-152/40, 4x1-120/40, 140mines
			2	Andromache	1891		
			3	Thetis	1892		
			4	Apollo	1892		
			5	Iphigenia	1893		
MS	Sharpshooter	5	1	Spanker	1890		735t, 70.1ppx8.2x3.2m, 4b,2vte, 3600hp, 19kts, 91p; 2x1-120/40, 4x1-47/40, 1-356TT, sweeps
			2	Speedwell	1890		
			3	Skipjack	1891		
			4	Seagull	1891		
			5	Gossamer	1891		
	Alarm	6	6	Jason	1893		810t, 70.1ppx8.2x3.7m, 4b,3vte, 3500(6-10)-5000(11)hp, 18.7(6-10)-20.5(11)kts, 91p; 2x1-120/40, 4x1-47/40, 1x5-11.4, 1-356TT, sweeps
			7	Circe	1893		
			8	Hebe	1894		
			9	Leda	1893		
			10	Niger	1893		
			11	Speedy	1894		
ATL	-	4	1	Seaflower	1908		275brt; 1x1-76/40, sweeps
			2	Seamew	1908		265brt; 1x1-76/40, sweeps
			3	Sparrow	1908		266brt; 1x1-76/40, sweeps
			4	Spider	1908		256brt

[home](#)[World navies yesterday](#)[1910](#)

United States of America 01 January 1910

CAPITAL SHIPS

	Texas	1	1		Texas	1895	A line drawing of the USS Texas (BB-3), a pre-dreadnought battleship, shown from a starboard profile view. It features two masts, two funnels, and a main battery of 10 152mm guns.	6665t, 94.1x19.5x6.9m, 4b,2vte, 8600hp, 17kts, 392p; Harvey: 305belt, 76deck, 305turrets, 305CT; 2x1-305/35, 2x1-152/35, 4x1-152/30, 10x1-57/45, 2x1-57/40, 6x1-37/40, 4x5-37/20, 4-356TT
	Indiana	2	BB1	Indiana	1895	A line drawing of the USS Indiana (BB-1), a pre-dreadnought battleship, shown from a starboard profile view. It features two masts, two funnels, and a main battery of 12 152mm guns.	11688t, 107.0x21.1x7/3m, 8b,2vte, 9000hp, 15kts, 473p; Harvey: 457belt, 76deck, 432turrets, 254CT; 2x2-330/35, 4x2-203/37, 12x1-76/50, 10x1-57/40	
		3	BB2	Massachusetts	1896			
		4	BB3	Oregon	1896			
	Iowa	1	5	BB4	Iowa	1897	A line drawing of the USS Iowa (BB-4), a pre-dreadnought battleship, shown from a starboard profile view. It features two masts, two funnels, and a main battery of 10 152mm guns.	12647t, 110.5x22.0x7.3m, 5b,2vte, 11000hp, 16kts, 486p; Harvey: 356belt, 76deck, 381turrets, 254CT; 2x2-305/35, 4x2-203/37, 10x1-102/40
	Kearsarge	6	BB5	Kearsarge	1900	A line drawing of the USS Kearsarge (BB-5), a pre-dreadnought battleship, shown from a starboard profile view. It features two masts, two funnels, and a main battery of 10 152mm guns.	12850t, 114.4x22.0x7.2m, 5b,2vte, 10000hp, 16kts, 553p; Harvey: 419belt, 127deck, 432turrets, 254CT; 2x2-330/35, 2x2-203/37, 14x1-127/40, 20x1-57/40, 8x5-37/20, 4-450TT	
		7	BB6	Kentucky	1900			
	Illinois	8	BB7	Illinois	1901	A line drawing of the USS Illinois (BB-7), a pre-dreadnought battleship, shown from a starboard profile view. It features two masts, two funnels, and a main battery of 10 152mm guns.	12250t, 114.4(8)-114.0(9,10)x22.0x7.2m, 8b,2vte, 10000hp, 16kts, 536p; Harvey: 419belt, 127deck, 356turrets, 254CT; 2x2-330/35, 14x1-152/40, 16x1-57/40, 6x1-37/40(8,10), 4c1-37/40(9), 4-450TT	
		9	BB8	Alabama	1900			
		10	BB9	Wisconsin	1901			
BB		11	BB10	Maine	1902			
		12	BB11	Missouri	1903			

MON	Maine	3							<p>13700t, 120.1x22.0x7.2-7.4m, 24b,2vte(11)-12b,2vte(12,13), 16000hp, 18kts, 561p; 279belt, 102deck, 305turrets, 254CT; 2x2-305/40, 16x1-152/49, 6x1-76/50, 8x1-47/40, 6x1-37/40, 2-450TT</p>
			13	BB12	Ohio	1904			
	Virginia	5	14	BB13	Virginia	1906		<p>16094t, 134.5x23.3x7.2m, 24b,2vte(14,16)-12b,2vte(15,17,18), 19000hp, 19kts, 812p; 279belt, 76deck, 305turrets, 229CT; 2x2-305/40, 4x2-203/45, 12x1-152/49(14-16), 12x1-152/50(17,18), 12x1-76/50, 12x1-47/40, 4-533TT</p>	
			15	BB14	Nebraska	1907			
			16	BB15	Georgia	1906			
			17	BB16	New Jersey	1906			
			18	BB17	Rhode Island	1906			
	Connecticut	2	19	BB18	Connecticut	1906		<p>17666t, 139.1x23.4x7.5m, 12b,2vte, 16500hp, 18kts, 827-896p; 279belt, 76deck, 279turrets, 229CT; 2x2-305/45, 4x2-203/45, 12x1-178/44, 20x1-76/50, 12x1-47/40, 4x1-37/40(19), 2x1-37/40(20), 4-533TT</p>	
			20	BB19	Louisiana	1906			
	Vermont	4	21	BB20	Vermont	1907		<p>17666t, 139.1x23.4x7.5m, 12b,2vte, 16500hp, 18kts, 850-880p; 229belt, 76deck, 305turrets, 229CT; 2x2-305/45, 4x2-203/45, 12x1-178/44, 20x1-76/50, 10x1-47/40(21), 12x1-47/40(22,23), 2x1-37/40, 4-533TT</p>	
			22	BB21	Kansas	1907			
			23	BB22	Minnesota	1907			
			24	BB25	New Hampshire	1908			
	Mississippi	2	25	BB23	Mississippi	1908		<p>14465t, 116.4x23.5x7.5m, 8b,2vte, 10000hp, 17kts, 744p; 229belt, 76deck, 305turrets, 229CT; 2x2-305/45, 4x2-203/45, 8x1-178/44, 12x1-76/50, 6x1-47/40, 2x1-37/40, 2-533TT</p>	
			26	BB24	Idaho	1908			
	MON	Amphitrite	4	1	M2	Amphitrite	1895		<p>3990t, 80.1(1)-79.9(2)-80.2(3,4)x16.9x4.4(1-3)-4.5(4)m, 4b,2hce(1)-4b,2hte(2)-6b,2hce(3,4), 1600(1,3,4)-3000(2)hp, 12(1,3,4)-14.5(2)kts, 150-191p; steel, iron: 229(1,2)-178(3,4)belt, 44deck, 190(1,2)-292(3,4)turrets, 190(1-3)-229(4)CT; 2x2-254/31(1-3), 1x2-254/35(4), 1x2-254/31(4), 2x1-102/40(1,2), 2x1-57/40, 2x5-37/20</p>
				2	M3	Monadnock	1896		
				3	M4	Terror (TS)	1896		
4				M5	Miantonomoh	1891			
Monterey		1	5	M6	Monterey	1893		<p>4084t, 79.5x18.0x4.5m, 4b,2vte, 5250hp, 13.6kts, 218p; Harvey: 330belt, 64deck, 203turrets, 254CT; 1x2-305/35, 1x2-254/31, 6x1-57/40</p>	

Arkansas	4	6	M7	Arkansas	1902		3225t, 77.8x15.2x3.8m, 4b,2vte, 2400hp, 12.5kts, 220p; Harvey: 279belt, 38deck, 254turret, 190CT; 1x2-305/40, 4x1-102/50, 3x1-57/40
		7	M8	Nevada	1903		
		8	M9	Florida	1903		
		9	M10	Wyoming	1902		







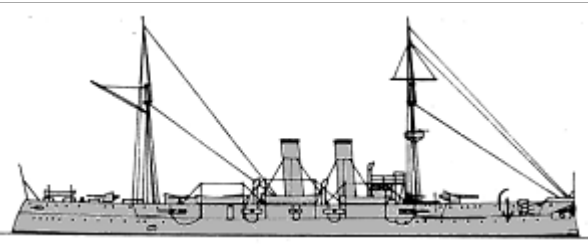
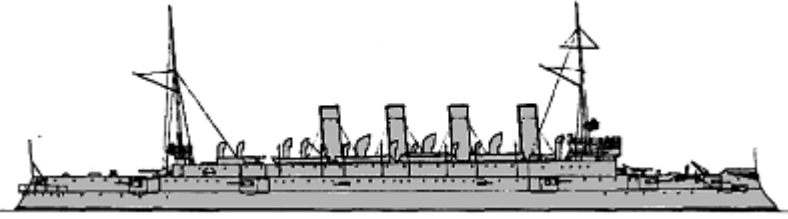
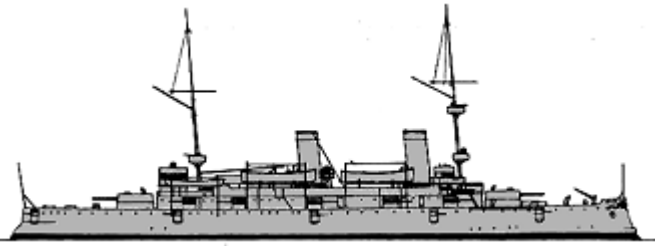
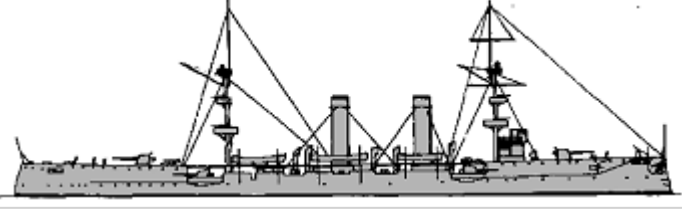
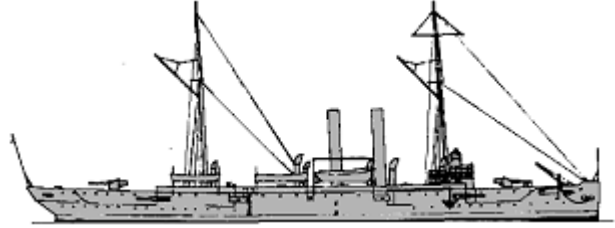
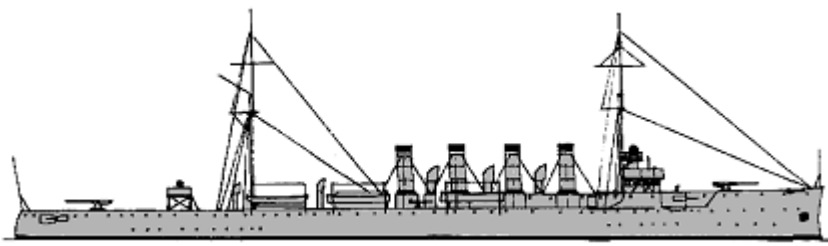
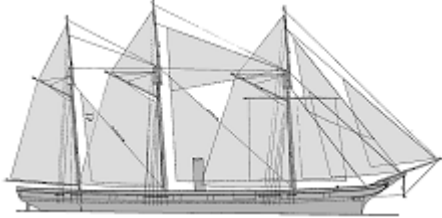



CRUISERS









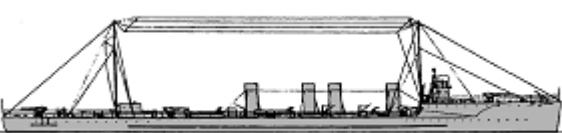



CA	New York	1	1	ACR2	New York	1893		9021t, 117.0x19.8x7.3m, 12b,2vte, 16000hp, 20kts, 566p; nickel steel: 102belt, 152deck, 165turrets, 190CT; 2x2-203/45, 10x1-127/50, 8x1-76/50
	Pennsylvania	6	3	ACR4	Pennsylvania	1905		15138t, 153.6x21.2x7.3m, 32b,2vte(3,6)-16b,2vte(4,5,7,8), 23000hp, 22kts, 829-928p; 152belt, 102deck, 165turrets, 229CT; 2x2-203/42, 14x1-152/49, 18x1-76/50, 12x1-47/45, 2x1-37/40, 2-450TT
			4	ACR5	West Virginia	1905		
			5	ACR6	California	1907		
			6	ACR7	Colorado	1905		
			7	ACR8	Maryland	1905		
			8	ACR9	South Dakota	1908		
	St. Louis	3	9	C20	St. Louis	1906		10839t, 129.9x20.1x6.9m, 16b,2vte, 21000hp, 22kts, 673-767p; Harvey: 102belt, 76deck, 102casemate, 127CT; 14x1-152/49, 18x1-76/50, 12x1-47/45, 8x1-37/40
			10	C21	Milwaukee	1906		
			11	C22	Charleston	1905		
	Tennessee	4	12	ACR10	Tennessee	1906		15715(12,13)-15981(14,15)t, 153.8x22.2x7.6m, 16b,2vte, 23000hp, 22kts, 856-914p; 127belt, 102deck, 229turrets, 229CT; 2x2-254/40, 16x1-152/49, 22x1-76/50, 12x1-47/45, 2x1-37/40(12,13), 4x1-37/40(14,15), 4-533TT
			13	ACR11	Washington	1906		
			14	ACR12	North Carolina	1908		
			15	ACR13	Montana	1908		

CL	Hartford	1	1		Hartford (TS)	1859	A three-masted sailing ship with a single funnel, shown in profile.	2550t, 68.6ppx13.4x7.1m, 2b,1vce, 696hp, 9.5kts, 310p; 16x1-229/15, 1x1-203/15, 13x1-127/40
	Atlanta	2	2		Atlanta	1886	A three-masted sailing ship with two funnels, shown in profile.	3189t, 86.3x12.8x5.2m, 8b,1hce, 3500hp, 13kts, 284p; steel: 38deck, 51barbettes; 2x1-203/31, 6x1-152/30, 2x1-57/40, 2x1-47/40, 2x1-37/20
			3		Boston	1887		
	Chicago	1	4		Chicago	1889	A three-masted sailing ship with two funnels, shown in profile.	5000t, 104.3x14.7x5.8m, 10b,2hte, 9000hp, 18kts, 471p; steel: 29belt, 38deck, 25battery, 76CT; 4x1-203/37, 14x1-127/40, 2x1-57/40, 2x1-37/20
	Baltimore	1	5	C3	Baltimore	1890	A three-masted sailing ship with two funnels, shown in profile.	5436t, 102.1x14.8x5.9m, 8b,2hte, 10750hp, 19kts, 386p; steel: 102slopes, 64deck, 76CT; 12x1-152/41, 4x1-57/40, 2x1-47/40, 2x1-37/20
	Newark	1	6	C1	Newark	1891	A three-masted sailing ship with two funnels, shown in profile.	4592t, 100.0x15.0x5.7m, 4b,2hte, 8500hp, 18kts, 384p; steel: 76slopes, 51deck, 76CT; 12x1-152/41, 4x1-57/40, 4x1-47/40, 2x1-37/20
	Montgomery	2	7	C10	Detroit	1893	A three-masted sailing ship with two funnels, shown in profile.	2235t, 82.1x11.3x4.4m, 6b,2vte, 5400hp, 17kts, 274p; steel: 13slopes, 13deck, 51CT; 9x1-127/40, 6x1-57/45, 2x1-37/40
			8	C11	Marblehead	1894		
Cincinnati	2	9	C7	Cincinnati	1894		3339t, 93.2x12.8x5.5m, 8b,2vte, 10000hp, 19kts, 322p; steel: 64slopes, 25deck, 102shields, 51CT; 11x1-127/40, 8x1-57/45, 2x1-37/40(9), 4x1-37/40(10)	
		10	C8	Raleigh	1894			

							
Columbia	2	11	C12	Columbia	1894		8270t, 125.9x17.7x6.9m, 8b,3vte, 21000hp, 21kts, 477p; steel: 102slopes, 64deck, 102casemates, 127CT; 3x1-152/40, 8x1-102/40, 12x1-57/45, 4x1-37/40, 4-450TT(12), 4-356TT(11)
		12	C13	Minneapolis	1894		
Olympia	1	13	C6	Olympia	1895		6558t, 104.9x16.2x6.6m, 6b,2vte, 13500hp, 20kts, 447p; Harvey: 121slopes, 51deck, 89turrets, 127CT; 2x2-203/37, 10x1-127/40, 14x1-57/45, 6x1-37/40
New Orleans	2	14		New Orleans	1898		4011t, 108.0x13.3x5.5m, 4b,2vte, 7500hp, 20kts, 366p; 89slopes, 32deck, 102CT; 10x1-127/50, 10x1-57/40, 8x1-37/20, 3-450TT
		15		Albany	1900		
Denver	6	16	C14	Denver	1904		3514t, 94.1x13.4x4.8m, 6b,2vte, 4500hp, 16.5kts, 339p; 64slopes, 8deck, 44casemates; 10x1-127/50, 8x1-57/50, 2x1-37/50
		17	C15	Des Moines	1904		
		18	C16	Chattanooga	1904		
		19	C17	Galveston	1905		
		20	C18	Tacoma	1904		
		21	C19	Cleveland	1903		
CLL Chester	3	1	CS1	Chester	1908		4687t, 129.0x14.3x5.1m, 12b,4st(1)-12b,2vte(2)-12b,2st(3), 16000hp, 24(1,3)-22.4(2)kts, 359p; 51belt, 25deck; 2x1-127/50, 6x1-76/50, 2-533TT
		2	CS2	Birmingham	1908		
		3	CS3	Salem	1908		
SL Alert	2	1		Alert	1875		1020t, 53.3ppx9.8x3.9m, 5b,1hcr, 380hp, 10kts, 148p; 1x1-279/15(1), 2x1-229/15(1), 1x1-135/21, 4x1-37/20(1)
		2		Ranger	1876		





TORPEDO SHIPS

DD	Farragut	1	1	TB11	Farragut	1899		279t, 65.2x6.3x1.8m, 3b,2vte, 5878hp, 30kts, 66p; 4x1-57/50, 2x1-450TT
	Bailey	1	2	TB21	Bailey	1901		235t, 62.5x5.8x1.8m, 4b,2vte, 5600hp, 30kts, 56p; 4x1-57/50, 2x1-450TT
	Bainbridge	3	DD1	Bainbridge	1902			420t, 76.2x7.2x2.0m, 4b,2vte, 8000hp, 29kts, 73p; 2x1-76/50, 5x1-57/50, 2x1-450TT
		4	DD2	Barry	1902			
		5	DD3	Chauncey	1902			
		6	DD4	Dale	1902			
		7	DD5	Decatur	1902			
	Paul Jones	8	DD10	Paul Jones	1903			480t, 76.4x7.2x2.2m, 4b,2vte, 8000hp, 29kts, 73p; 2x1-76/50, 5x1-57/50, 2x1-450TT
		9	DD11	Perry	1902			
		10	DD12	Preble	1903			
	Stewart	1	11	DD13	Stewart	1902		420t, 76.3x7.2x2.0m, 4b,2vte, 8000hp, 29kts, 71p; 2x1-76/50, 5x1-57/50, 2x1-450TT
	Truxtun	12	DD14	Truxtun	1902			433t, 79.1x7.1x1.8m, 4b,2vte, 8300hp, 30kts, 73p; 2x1-76/50, 6x1-57/50, 2x1-450TT
		13	DD15	Whipple	1902			
		14	DD16	Worden	1902			
	Hopkins	15	DD6	Hopkins	1903			408t, 75.8x7.5x1.8m, 4b,2vte, 7200hp, 29kts, 78p; 2x1-76/50, 6x1-57/50, 2x1-450TT
		16	DD7	Hull	1903			
	Lawrence	17	DD8	Lawrence	1903			430t, 75.1x6.8x2.0m, 4b,2vte, 8400hp, 28.4kts, 78p; 7x1-57/50, 2x1-450TT
		18	DD9	MacDonough	1903			
	Stringham	1	19	TB19	Stringham	1905		340t, 69.6x6.7x2.0m, 4b,2vte, 7200hp, 30kts, 59p; 4x1-57/50, 2x1-450TT
	Goldsborough	1	20	TB20	Goldsborough	1908		255t, 60.4x6.3x2.1m, 3b,2vte, 6000hp, 27kts, 59p; 4x1-57/50, 2x1-450TT
Smith	21	DD17	Smith	1909			900t, 89.6x7.9x2.4m, 4b,3st, 10000hp, 28kts, 87p; 5x1-76/50, 3x1-450TT	
	22	DD19	Preston	1909				
	23	DD20	Flusser	1909				
	24	DD21	Reid	1909				

TB	Stiletto	1	1	WTB1	Stiletto	1887	No picture	31t, 28.6x3.5x0.9m, 1b,1vc, 359hp, 18.2kts, 6p; 2Howel torps
	Cushing	1	2	TB1	Cushing	1890		116t, 42.7x4.6x1.5m, 2b,2vqe, 1600hp, 23kts, 22p; 3x1-57/40, (1+2x1)-450TT
	Ericsson	1	3	TB2	Ericsson	1897		120t, 45.6x4.7x1.5m, 2b,2vqe, 1800hp, 24kts, 22p; 4x1-37/40, (1+2x1)-450TT
	Foote	3	4	TB3	Foote	1897		142t, 48.8x4.9x1.5m, 2b,2vte, 2000hp, 25kts, 20p; 3x1-37/40, 3x1-450TT
			5	TB4	Rodgers	1898		
			6	TB5	Winslow	1897		
	Porter	2	7	TB6	Porter	1897		165t, 53.5x5.4x1.4m, 3b,2vqe, 3200hp, 27.5kts, 24p; 4x1-37/40, 3x1-450TT
			8	TB7	DuPont	1897		
	Morris	1	9	TB14	Morris	1898		105t, 42.5x4.7x1.2m, 2b,2vte, 1750hp, 23kts, 26p; 3x1-37/40, 3x1-450TT
	Talbot	2	10, 11	TB15, 16	Talbot, Gwin	1898	No picture	46t, 30.5x3.8x1.0m, 1b,1vte, 850hp, 20kts, 12p; 1x1-37/40, 2x1-450TT
	MacKenzie	2	12, 13	TB17, 18	MacKenzie, McKee	1898-1899	No picture	65t, 30.9x3.9x1.3m, 2b,1vte, 850hp, 20kts, 12p; 1x1-37/40(13), 2x1-37/40(14), 2x1-450TT
	Somers	1	14	TB22	Somers	1898	No picture	143t, 47.6x5.3x1.8m, 1b,1vqe, 1700hp, 23kts, 24p; 4x1-37/40, (1+2x1)-450TT
	Rowan	1	15	TB8	Rowan	1899		182t, 51.8x5.2x1.8m, 3b,2vqe, 3200hp, 26kts, 24p; 4x1-37/40, 3x1-450TT
	Davis	2	16	TB12	Davis	1899		155t, 45.1x4.7x1.8m, 2b,2vte, 1750hp, 23kts, 24p; 3x1-37/40, 3x1-450TT
			17	TB13	Fox	1899		
	Dahlgren	2	18	TB9	Dahlgren	1900		146t, 46.1x5.0x1.4m, 2b,2vte, 4200hp, 31kts, 29p; 4x1-37/40, 2x1-450TT
			19	TB10	Craven	1900		
	Bagley	3	20	TB24	Bagley	1901	No picture	168t, 47.9x5.2x1.5m, 2b,2vte, 4200hp, 28kts, 29p; 3x1-37/40, 3x1-450TT
			21	TB25	Barney	1901		
			22	TB26	Biddle	1901		
Shubrick	3	23	TB31	Shubrick	1901		200t, 53.4x5.4x1.9m, 3b,2vte, 3375hp, 26(23)-25(24,25)kts, 28(23)-29(24,25)p; 3x1-47/45(24,25), 3x1-37/40(23), 3x1-450TT	
		24	TB32	Stockton	1901			
		25	TB33	Thornton	1902			
Blakely	2	26	TB27	Blakely	1904		196t, 53.4x5.2x1.8m, 3b,2vte, 3000hp, 26kts, 28-29p; 3x1-37/40, 3x1-450TT	
		27	TB28	De Long	1902			
Wilkes	1	28	TB35	Wilkes	1902		175t, 53.4x5.4x1.4m, 3b,2vte, 3000hp, 27kts, 29p; 3x1-37/40, 3x1-450TT	
Tingey	1	29	TB34	Tingey	1904		165t, 53.4x5.4x1.4m, 3b,2vte, 3000hp, 25kts, 29p; 3x1-37/40, 3x1-450TT	

SUBMARINES

	Holland	1	1	SS1	Holland	1900		64/74t, 16.4x3.1x2.6m, 1pe/em, 45/50hp, 8/5kts, 7p, 25m; 1x1-203/40pneumatic, 1-450TT
			2	SS2	Plunger	1903		
			3	SS3	Adder	1903		
			4	SS4	Grampus	1903		





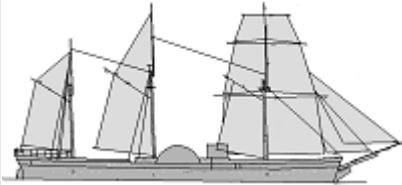
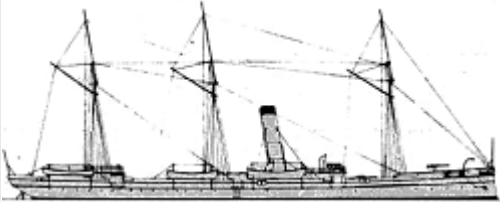

SS	A	7	5	SS5	Moccasin	1903		107/123t, 19.5x3.6x3.2m, 1pe/em, 160/150hp, 8/7kts, 7p, 25m; 1-450TT
			6	SS6	Pike	1903		
			7	SS7	Porpoise	1903		
			8	SS8	Shark	1903		
	B	3	9	SS10	Viper	1907		145/173t, 25.1x3.8x3.2m, 1pe/em, 250/150hp, 9/8kts, 10p, 45m; 2-450TT
			10	SS11	Cuttlefish	1907		
			11	SS12	Tarantula	1907		
	C	4	12	SS9	Octopus	1908		238/275t, 32.1x4.2x3.0m, 2pe/em, 500/300hp, 10.5/9kts, 15p, 60m; 2-450TT
			13	SS13	Stingray	1909		
			14	SS14	Tarpon	1909		
			15	SS15	Bonita	1909		
	D	2	16	SS17	Narwhal	1909		288/337t, 41.1x4.2x3.6m, 2pe/em, 600/260hp, 12/9.5kts, 15p, 60m; 4-450TT
			17	SS18	Grayling	1909		

ESCORTS

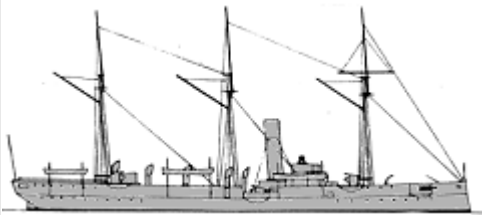
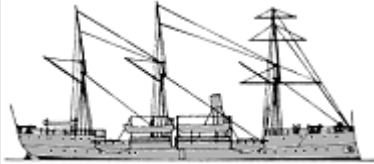
AY	-	9	1	Mayflower	1896	2690t, 83.2x11.0x5.3m, 2vte, 4700hp, 16.8kts; 2x1-127/40, 12x1-57/40
			2	Dorothea	1897	594t
			3	Eagle	1890	850t
			4	Gloucester	1891	786t
			5	Hawk	1891	545t
			6	Hornet	1890	425t
			7	Scorpion	1896	850t
			8	Vixen	1896	806t
			9	Wasp	1898	630t

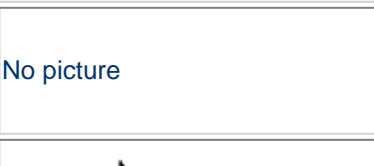
OTHER FIGHTING SHIPS

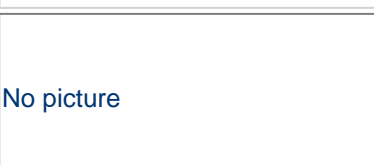
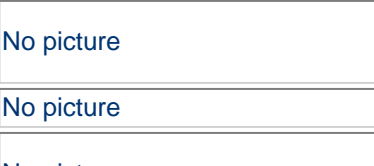
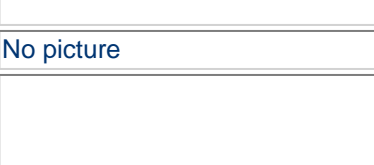
Michigan	1	1		Michigan	1844		686t, 49.5ppx8.2x3.7m, 1b,1dse(sw), 110hp, 12kts, 148p; 6x1-47/40
Dolphin	1	2		Dolphin	1884		1486t, 78.2x9.8x4.4m, 4b,1vc, 2255hp, 16kts, 152p; 1x1-152/30, 2x1-57/40, 4x5-37/20
Yorktown	2	3	PG1	Yorktown	1889		1921t, 74.5x11.0x4.3m, 4b,2hte, 3400hp, 16kts, 187-201p; 51CT; 6x1-152/30(3), 6x1-152/35(4), 2x1-57/40(4), 4x1-47/40(3), 2x1-47/40(4), 4x1-37/40(3), 2x1-37/40(4)
		4	PG3	Concord	1889		

			26	PG18	Paducah	1905		
APG	-	1	1	PG35	Topeka	1881		2372t, 76.2x10.7x5.4m, 4b,2hce, 2200hp, 16kts; 8x1-102/40, 2x1-57/50, 4x1-47/45, 2x1-37/40

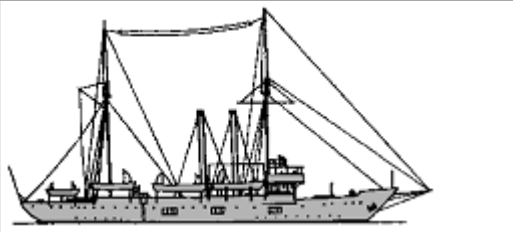
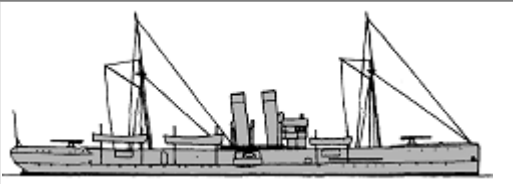
MINE WARFARE SHIPS

ML	San Francisco	1	1	C5	San Francisco	1890		4583t, 98.9x15.0x5.7m, 8b,2hte, 10500hp, 19kts, 384p; steel: 76slopes, 51deck, 76CT; 8x1-127/40, 180mines
----	---------------	---	---	----	---------------	------	--	---

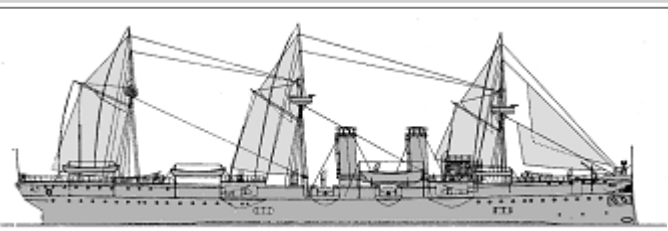
COAST GUARD CUTTERS

CGC	Manhattan	1	1		Manhattan	1873	No picture	147t, 31.1x6.2x2.6m, 1vce, 16p; 1x1-57/40	
	Dallas	1	2		Rush	1874	No picture	300t, 53.4x7.9x3.8m, 1b,1vce, 400hp, 9.5kts, 40p; 3x1-57/40	
	Walter Forward	1	3		Walter Forward	1882	No picture	267t, 47.3x7.6x2.3m, 2vce, 38p; 2x1-	
	Commodore Perry	1	4		Commodore Perry	1884	No picture	282t, 50.3x7.6x3.4m, 1hdase, 41p; 2x1-	
	Bear	1	5		Bear	1874	No picture	703t, 60.5x9.2x5.5m, 1b,1vce, 51p; 3x1-57/40	
	Lot M. Morrill	1	6		Lot M. Morrill	1889	No picture	288t, 44.3x7.3x2.9m, 1b,1vce, 13kts, 38p; 1x1-76/50, 2x1-57/40	
	Winona	1	7		Winona	1890	No picture	321t, 45.3x8.0x1.8m, 2vce, 600hp, 39p; 1x1-	
	Galveston	1	8		Apache	1891	No picture	708t, 57.9x8.8x2.8m, 2b,1vte, 1200hp, 12kts, 41p; 4x1-57/40	
	Bancroft	1	9		Itasca	1893	No picture	839t, 57.6x9.8x3.7m, 2b,2vte, 1200hp, 14.5kts, 148p; 4x1-57/50	
	William Windom	1	10		William Windom	1896	No picture	670t, 52.0x8.2x2.9m, 2b,2vte, 800hp, 15kts, 49p; 3x1-47/40	
	Gresham		4	11	CG1	Gresham	1897	No picture	1190t, 62.6x9.8x3.4m, 4b,1vte, 2500hp, 17kts, 73p; 4x1-57/40
				12	CG2	Manning	1898		
				13	CG4	Algonquin	1898		
				14	CG5	Onondaga	1898		
	McCulloch	1	15		McCulloch	1897	No picture	1280t, 66.8x10.2x4.3m, 2b,1vte, 17kts, 130p; 4x1-76/50, 1-450TT	
	Thetis	1	16		Thetis	1881	No picture	1250t, 57.5x8.9x5.4m, 1vce; 3x1-47/40	
	Seminole	1	17		Seminole	1900	No picture	860t, 57.3x8.8x3.4m, 2b,1vte, 14.7kts, 67p; 4x1-57/40	
Tuscarora	1	18		Tuscarora	1902	No picture	739t, 54.3x9.1x3.4m, 2b,1vte, 14.2kts, 65p; 1x1-57/45		
Mohawk	1	19		Mohawk	1904	No picture	980t, 62.7x9.8x3.8m, 1vte, 71p; 2x1-57/40		
Pamlico	1	20	CG15	Pamlico	1907	No picture	455t, 48.2x9.1x1.7m, 1b,2vte, 600hp, 9.8kts, 33p; 2x1-47/45		

Androscoggin	1	21	CG14	Androscoggin	1908	No picture	1605t, 64.0x10.7x5.3m, 2b,1vte, 1800hp, 13kts, 74p; 4x1-57/45
Tahoma	2	22	CG20	Tahoma	1909	No picture	1082t, 58.2x9.8x4.3m, 1vte, 14.1kts, 69p; 2x1-57/45
		23	CG21	Yamacraw	1909		
Snohomish	2	24	CG16	Snohomish	1908	No picture	879t, 46.3x8.8x4.2m, 1b,1vte, 1200hp, 12kts, 53p; 2x1-37/45
		25		Acushnet	1908		
Seneca	1	26	CG17	Seneca	1908	No picture	1445t, 62.2x10.4x5.2m, 2b,1vte, 1500hp, 12.5kts, 74p; 4x1-57/45

© Ivan Gogin, 2014

[home](#)[World navies yesterday](#)[1910](#)

Uruguay 01 January 1910

CRUISERS

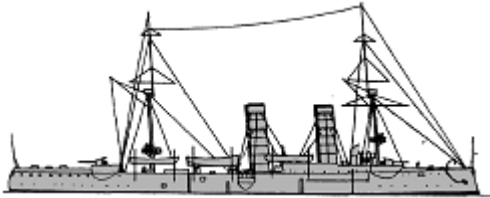
CL	24 de Agosto	1	1	24 de Agosto	1887		2050t, 76.2x11.3x4.4m, 4b,2vte, 5012hp, 17.7kts, 250p; compound- 51deck, 114shields, 51CT; 6x1-152/32, 9x1-57/40, 4-350TT
----	--------------	---	---	--------------	------	--	---

ESCORTS

AY	-	1	1	18 de Julio	1884	678t
----	---	---	---	-------------	------	------

OTHER FIGHTING SHIPS

PG	General Artigas	1	1	General Artigas	1883	No picture	270t, 39.0x6.3x2.6m, 1hc, 520hp, 12.5kts; 2x1-120/27
	Malvinas	1	2	Malvinas	1885	No picture	400t, 43.0x7.0x3.1m, 280hp, 8kts; 2x1-small guns
	General Suárez	1	3	General Suárez	1864	No picture	405t, 38.8x6.7x3.0m, 205hp, 9kts, 62p; 4x1-79/27
PGR	Maldonado	1	1	Barón de Río Branco	1886	No picture	300t, (stw), 12kts; 4x1-small guns

© Ivan Gogin, 2015

[home](#)[World navies yesterday](#)[1910](#)

Venezuela 01 January 1910

TORPEDO SHIPS

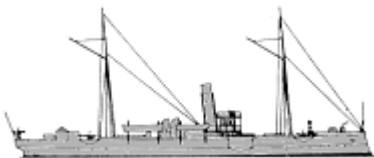
PGT	Bolívar	1	1	Bolívar	1894		630t, 58.0ppx6.7x3.2m, 4b,2vte, 2600hp, 19kts, 91p; steel- 13deck; 2x1-120/35, 4x1-57/42, 1x4-25/42, 2x1-356TT
-----	---------	---	---	---------	------	---	--

OTHER FIGHTING SHIPS

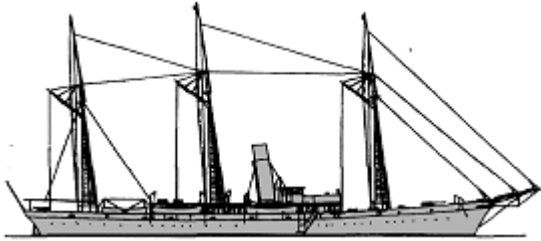
PG	Miranda	1	1	Miranda	1895	No picture	200t, 41.5x5.8x2.5m, 1b,1vte, 315hp, 10kts, 55p; 4x1-57/42
APG	-	2	1	Restaurador	1884		750t; 1x1-76/40
			2	Jose Felix Ribas	1894		300t

© Ivan Gogin, 2015