

[home](#)

THE NAVAL BALANCE 1905

Navies of the world

01/01/1905

1. United Kingdom - 1695 tt; France - 635 tt; 3. Russia - 513 tt; 4. Germany - 462 tt; 5. USA - 362 tt; 6. Japan - 297 tt; 7. Italy - 289 tt; 8. Austria-Hungary - 127 tt

tt - thousand ton



[Argentina](#)

[Australia](#)

[Austria-Hungary](#)

[Belgium](#)

[Brazil](#)

[Bulgaria](#)

[Cambodia](#)

[Chile](#)

[China](#)

[Colombia](#)

[Costa Rica](#)

[Cuba](#)

[Denmark](#)

[Dominican Republic](#)

[Ecuador](#)

[Egypt](#)

[El Salvador](#)

[France](#)

[Germany](#)

[Greece](#)

[Haiti](#)

[Honduras](#)

[Italy](#)

[Japan](#)

[Mexico](#)

[Morocco](#)

[Netherlands](#)

[Norway](#)

[Ottoman Empire](#)

[Persia](#)

[Peru](#)

[Portugal](#)

[Romania](#)

[Russia](#)

[Sarawak](#)

[Siam](#)

[Spain](#)

[Sweden](#)

[United Kingdom](#)

[United States of America](#)

[Uruguay](#)

[Venezuela](#)

1576469

[Website Hit Counter](#)

© Ivan Gogin, 2015



[home](#)[World navies yesterday](#)[1905](#)

Argentina 01 January 1905

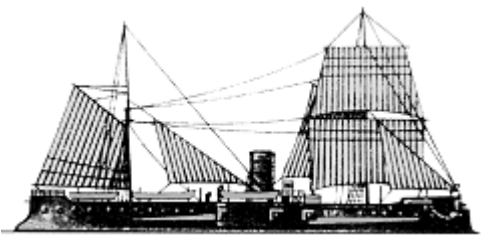
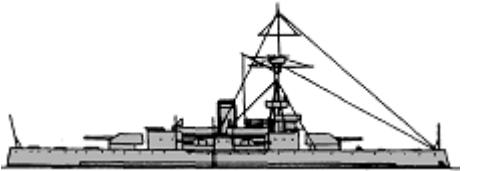
BATTLESHIPS



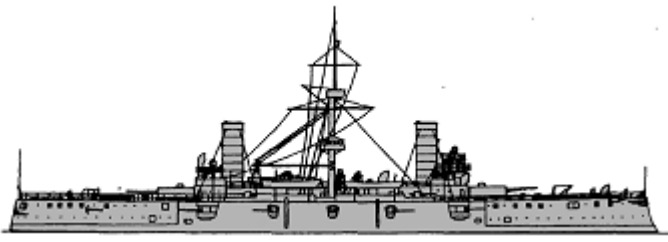

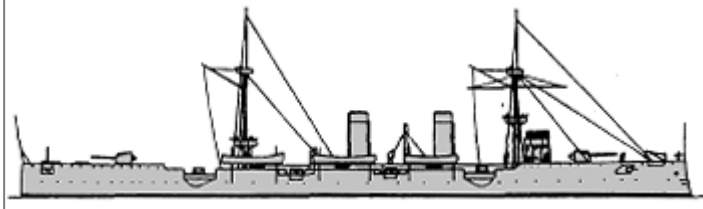
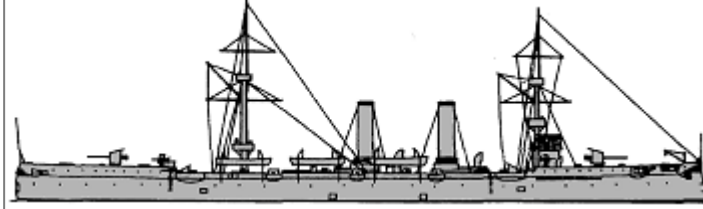
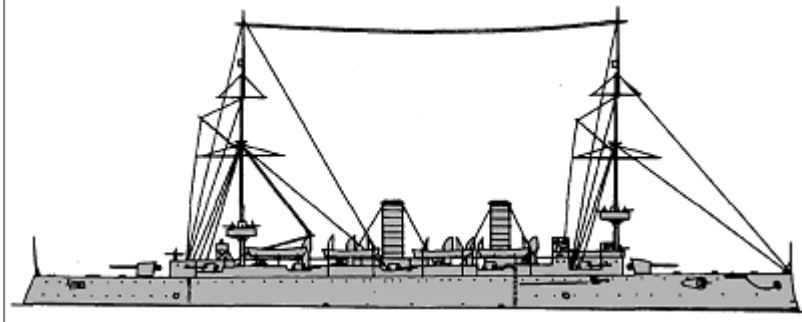

	El Plata	1	El Plata	1875		1500t, 56.7x13.4x3.2m, 4b,2vc, 750hp, 9.5kts, 126p; iron- 152belt, 30deck, 229turret; 1x2-203/30, 2x1-120/40, 2x1-57/40, 4x1-25/42
		2	Los Andes	1875		
BC	Almirante Brown	1	Almirante Brown	1882		4200t, 73.2ppx15.2x6.3m, 8b,2vc, 5400hp, 14kts, 520p; compound- 229belt, 203battery, 203CT; 10x1-150/50, 6x1-120/50, 2x1-47/40, 2-450TT
	Libertad	4	Libertad	1892		2595t, 70.1ppx13.1x4.0m, 4b,2vte, 2780hp, 14.2kts, 230p; steel- 203belt, 37deck, 203barbettes, 102CT; 2x1-238/32, 4x1-120/41, 4x1-47/42, 2-450TT
		5	Independencia	1892		

CRUISERS

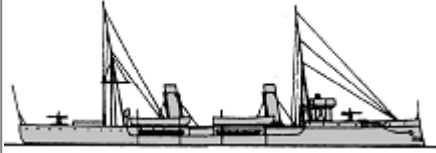
CA	Garibaldi	1	Garibaldi	1896		6775t, 111.7x18.2x7.1m, 8b,2vte(1-3)-16b,2vte(4), 13000hp, 20kts, 500-540p; Harvey(1-3)- 150belt, 150turrets, 37deck, 150CT; 2x1-254/40(1,3,4), 2x2-203/45(2), 10x1-152/40(1,2), 14x1-152/40(3,4), 6x1-120/41(1,2), 2x1-76/40(3,4), 10x1-57/40, 10x1-37/20(1,2), 12x1-37/20(3,4)
		2	San Martin	1898		
		3	General Belgrano	1898		
		4	Pueyrredon	1898		
	Patagonia	1	Patagonia	1887		1530t, 64.9ppx10.0x3.9m, 2b,2hc, 2730hp, 14kts, 140p; steel- 102shield, 32deck, 38CT; 1x1-254/33, 3x1-152/31, 4x1-76/26
	Veinticinco	1	Veinticinco	1891		3500t, 107.9x13.4x4.9m, 4b,2vte, 14050hp, 22.4kts, 320p; steel- 114slopes, 89deck, 51shields,

						102CT; 1x1-209/32, 8x1-120/37, 12x1-47/37, (1+2x1)-450TT
CL	Nueve de Julio	1 3	Nueve de Julio	1893		3600t, 113.5x13.4x5.0m, 8b,2vte, 14500hp, 22.2kts, 327p; steel- 114slopes, 89deck, 51shields, 102CT; 4x1-152/40, 8x1-120/41, 12x1-47/40, 5-450TT
	Buenos Aires	1 4	Buenos Aires	1896		4788t, 129.2x12.9x5.6m, 8b,2vte, 17000hp, 24kts, 350p; steel- 127slopes, 38deck, 114shields, 152CT; 2x1-203/45, 4x1-152/45, 6x1-120/44, 16x1-47/40, 5-450TT

TORPEDO SHIPS

PGT	Espera	1 1	Espera	1890		520t, 64.0x7.6x2.5m, 4b,2vte, 3420hp, 19.4kts, 47p; 2x1-76/46, 1x1-63/42, 2x1-47/42, (1+2x2)-450TT
	Patria	1 2	Patria	1894		1029t, 76.7x9.6x3.0m, 4b,2vte, 5000hp, 20.5kts, 100p; 2x1-120/41, 4x1-63/42, 2x1-47/42, 5-450TT
DD	Corrientes	1	Corrientes	1898		280t, 57.9x5.9x2.2m, 6b,2vte, 4200hp, 27kts, 54p; 1x1-76/46, 3x1-57/42, (1+2x1)-450TT
		2	Entre Rios	1896		
		3	Misiones	1897		
TB	Ferré	4 1-4	Ferré, Enrique Py, Centella, Alerta	1880-1882		52t, 30.5x3.8x1.8m, 1b,1vc, 500hp, 18.5-20kts, 11p; 2x4-25/42, 2-356TT
	Nr.1	2 5, 6	Nr.1, 2	1881	No picture	17t, 18.4x2.3x1.1m, 1b,1vc, 230hp, 16kts, 10p; 1spar torpedo
	Nr.1	8 7-14	Nr.1-8	1890		16t, 18.3x2.8x1.1m, 1b,1vte, 230-250hp, 17-18kts, 10p; 1x1-47/42, 1x1-356TT
	Bouchard	6 15-20	Bouchard, Bathurst, Jorge, King, Pinedo, Thorne	1890-1892		90t, 39.6ppx4.3x1.8m, 2b,2vte(15,17-20)-2b,1vqe(16), 1110(15,17-20)-1230(16)hp, 23.5(15,17-20)-24.4(16)kts, 15p; 2x1-47/42, 1x4-25/42, (1+1x2)-450TT
	Comodoro Py	2 21-22	Comodoro Py Comodoro Murature	1892 1892	No picture	110t, 45.7x4.4x1.1m, 2b,1vte, 1800hp, 25kts, 27p; 2x1-47/42, 1x4-25/42, (1+1x2+1x1)-450TT

OTHER FIGHTING SHIPS

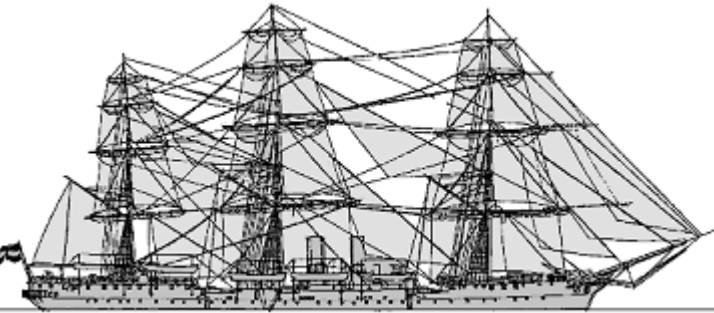

PG	Pilcomayo	1	República	1876		420t, 33.5x9.1x2.4m, 2b,2hc, 430hp, 9.7kts, 100p; 1x1-279/14, 2x1-79/25, 2x1-63/42
		2	Constitución	1876		
CT	Presidente Sarmiento	1	Presidente Sarmiento	1898		2733t, 85.5ppx13.3x5.9m, 4b,2vc, 1800hp, 13kts, 305+40p, 4x1-120/43, 6x1-57/42, 2x1-37/27, 3-356TT

© Ivan Gogin, 2015

[home](#)[World navies yesterday](#)[1905](#)

Australia 01 January 1905

TORPEDO SHIPS

PGT	Sharpshooter	1	Boomerang	1891		735t, 70.1ppx8.2x3.2m, 4b,2vte, 3600hp, 19kts, 91p; 2x1-120/40, 4x1-47/40, (1+2x2)-356TT
		2	Karakatta	1891		
TB	Childers	1	Childers	1884	No picture	61t, 35.5x3.8x1.7m, 1b,1hce, 679hp, 18kts, 18p; 2x1-37/30, 2-381TT
	Countess of Hopetown	1	Countess of Hopetown	1890		82t, 36.6x4.1xm, 1b,1vte, 1150hp, 23kts, 19p; 3x1-47/40, (2+1x1)-356TT
TB2cl	Gordon	1	Gordon	1886	No picture	12t, 17.1x2.9x1.5m, 1b,1csce, 150hp, 15kts, 11p; 3x1-25/40, 2-356TC
	Midge	1	Midge	1888	No picture	12t, 17.2x2.8x1.4m, 1b,1hce, hp, kts, p; 2x2-25/40, 1spar torpedo
	Defender	4	Nepean, Lonsdale, No191, Mosquito	1883 - 1884	No picture	12t, 19.2ppx2.3x1.2m, 1b,1hce, 17kts, 7p; 1x2-25/40, 1-356TT

OTHER FIGHTING SHIPS

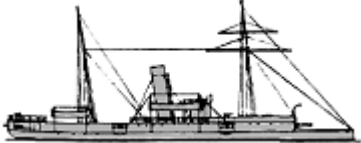
PG	Protector	1	Protector	1884		920t, 57.3x9.1x3.8m, 4b,2vce, 1500hp, 14kts, 90p; 1x1-203/26, 5x1-152/31, 4x1-47/40, 5x1-11.4
	Paluma	2	Paluma	1884	No picture	360t, 36.6x7.9x2.9m, 1b,2vce, 400hp, 10.5kts, p; 1x1-203/26(54), 1x1-152/31, 2x1-37/30, 2x1-11.4
		3	Gayundah	1884		

Google
Custom Search



© Ivan Gogin, 2014

[home](#)[World navies yesterday](#)[1905](#)

Austria-Hungary 01 January 1905

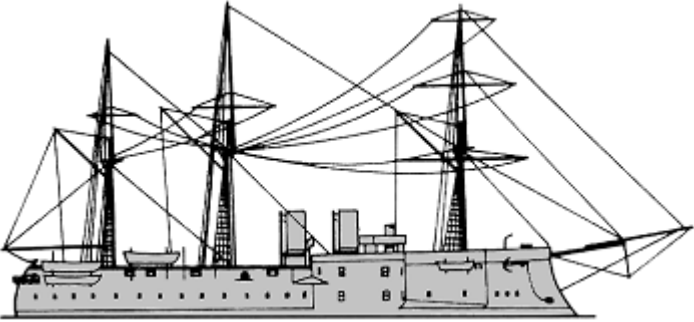
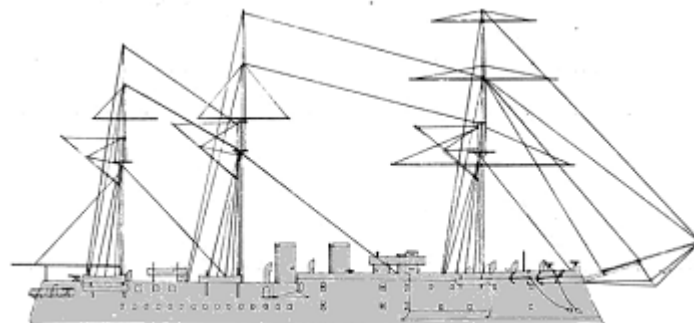
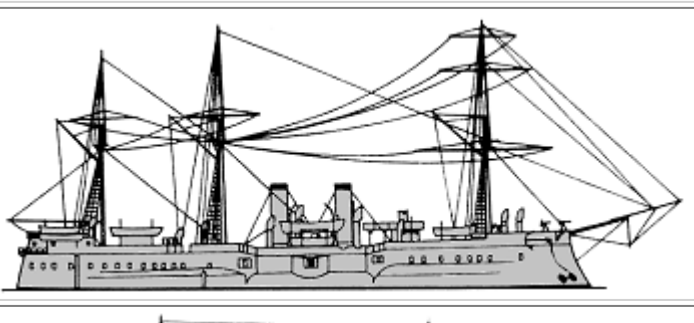
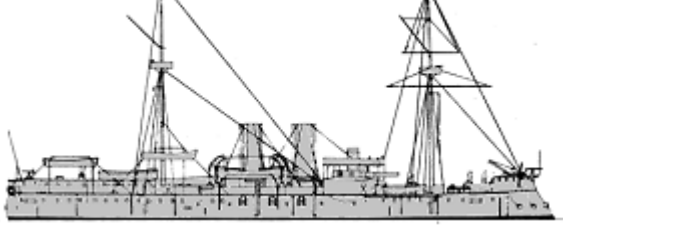
BATTLESHIPS

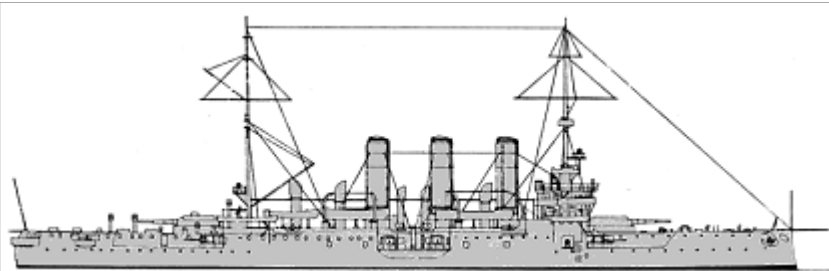
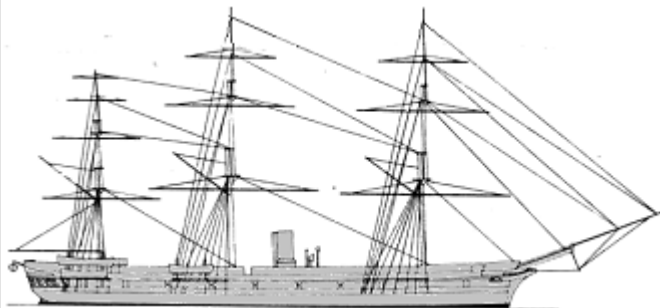
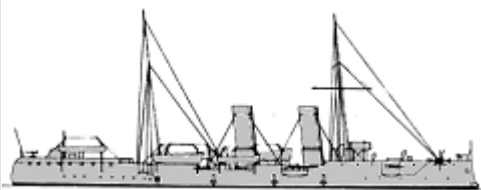

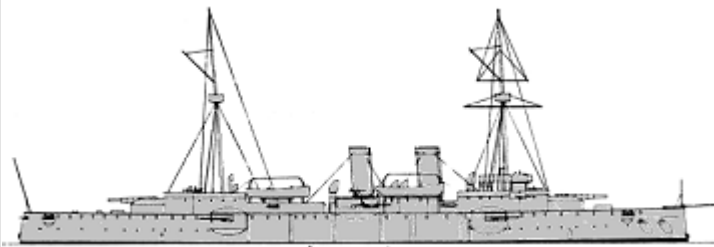
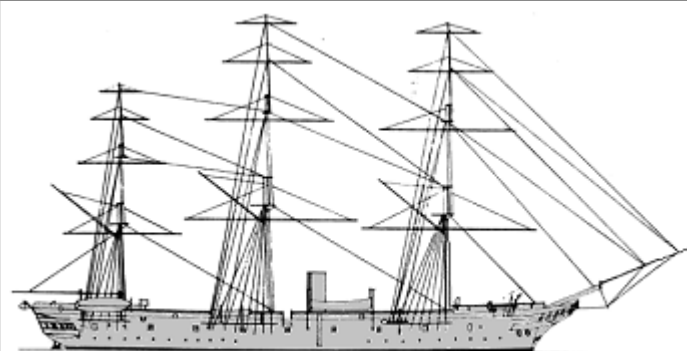

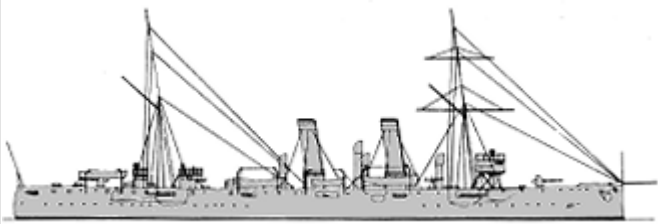
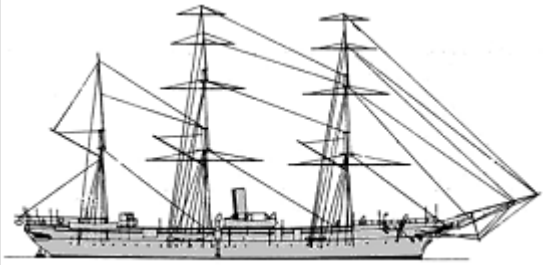



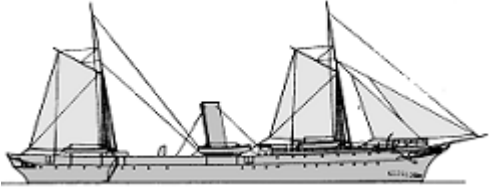
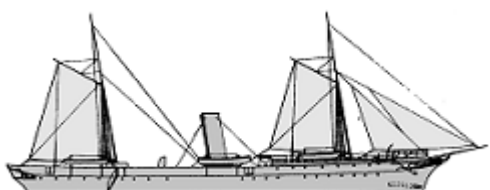
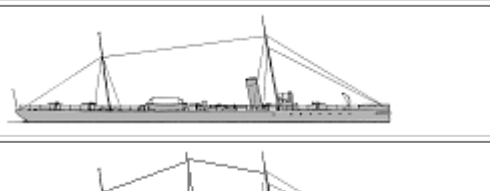
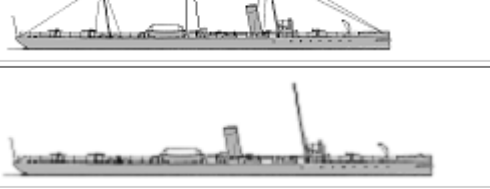
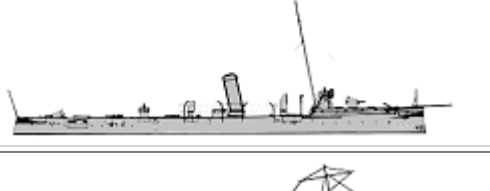
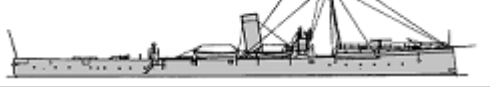



						5980t, 89.7x17.2x6.7m, 8b,1hr, 3969hp, 12.8kts, 540p; iron- 205belt, 175casemates; 8x1-235/20, 6x1-87/22, 2x1-66/16, 4x1-47/30, 5x5-47/22, 2x5-25/41, 4-356TT
						7731t, 95.0x17.7x7.9m, 8b,1hr, 4158hp, 13.7kts, 548p; iron- 230belt, 175casemates; 8x1-263/20, 6x1-87/22, 2x1-66/16, 4x1-47/30, 5x5-47/22, 2x5-25/41, 4-356TT
						7431t, 89.4x21.8x7.6m, 8b,2vt, 8160hp, 15.3kts, 575p; iron- 370belt, 40deck, 370casemates, 175CT; 6x1-235/32, 5x1-149/33, 2x1-66/16, 9x1-47/40, 6x1-47/30, 2-356TT
BB						5075t, 87.2x17.1x6.6m, 10b,2vc, 8000hp, 17kts, 430p; compound- 230belt, 25deck, 280turrets, 50CT; 2x1-305/32, 6x1-149/33, 2x1-66/16, 7x1-47/40, 2x1-47/30, 2x1-37/20, 4-400TT

							
	Saida	1	1	Saida	1879		2662t, 79.4x13.1x5.8m, 4b,1hse, 1790hp, 12kts, 359p; 8x1-149/24, 1x1-66/16, 2x1-47/30
	Panther	2	2	Panther	1885		1557t, 73.2x10.4x4.3m, 6b,2vc, 5940(2)-6380(3)hp, 18.4(2)-18.7(3)kts, 186p; steel- 12deck; 2x1-120/31, 4x1-47/40, 6x5-47/22, 4-356TT
		3	3	Leopard	1886		
	Tiger	1	4	Tiger	1888		1657t, 76.0x10.6x4.3m, 6b,2vc, 5700hp, 18.6kts, 188p; steel- 12deck; 4x1-120/31, 6x1-47/40, 4x5-47/22, 4-356TT
CL	Kaiser Franz Joseph I	5	5	Kaiser Franz Joseph I	1890		4494t, 103.7x14.8x5.7m, 10b,2hte, 8450hp, 19kts, 367p; steel- 57hull, 38deck, 90barbettes, 50CT; 2x1-238/32, 6x1-149/33, 2x1-66/16, 5x1-47/40, 4x1-47/30, 3x1-37/20, 4-400TT
		6	6	Kaiserin Elisabeth	1892		
	Donau	1	7	Donau	1894		2306t, 70.0x12.8x5.6m, 4b,1vc, 1300hp, 10kts, 333p; 10x1-120/31, 1x1-66/16, 4x5-25/41
	Zenta	8	8	Zenta	1899		2503(8)-2625(9)-2562(10)t, 96.9x11.7x4.2m, 8b,2vte, 8160hp, 20.8kts, 308p; steel- 50slopes, 40deck, 35casemates, 50CT; 8x1-120/37, 8x1-
		9	9	Aspern	1900		
		3	3				

			10	Szigetvár	1901		47/40, 2x1-47/30, 2-450TT
CLL	Zrinyi	1	1	Zrinyi	1871		1353t, 69.1x10.5x5.0m, 2b,1hse, 1000hp, 11kts, 210p; 2x1-149/18, 4x1-87/22, 2x1-66/16, 2x5-47/22

TORPEDO SHIPS

PGT	Zara	1	Zara	1881		852t, 67.2x8.2x3.7m, 5b,2vc, 2600hp, 14.3kts, 148p; 4x1-87/22, 1x1-66/16, 4x1-47/30, 1x5-47/22, 2x5-25/41, (2+2x1)-356TT	
		2	Spalato	1880		890t, 69.7x8.2x3.4m, 4b,2vc, 1344hp, 12.8kts, 135p; 2x1-120/37, 1x1-66/16, 4x1-47/40, 4x1-47/30, 4x1-37/20	
	Sebenico	1	3	Sebenico	1882		426t, 59.0ppx6.9x2.1m, 2b,1vte, 2600hp, 21kts, 61p; 8x1-47/40, (1+1x1)-450TT(5), (1+1x1)-356TT(4)
	Blitz	2	4	Blitz	1888		436t, 57.0ppx6.8x2.6m, 2b,1vte, 2600hp, 21kts, 60p; 9x1-47/30, (1+1x1)-450TT
			5	Komet	1889		525t, 67.1x7.0x2.8m, 4b,2vte, 3500hp, 19.6kts, 84p; 2x1-66/37, 8x1-47/40, (1+1x1)-450TT
	Meteor	1	6	Meteor	1889		540t, 67.0x8.0x2.4m, 4b,2vte, 3800hp, 20.1kts, 84p; 2x1-66/37, 8x1-47/40, (1+1x1)-450TT
	Planet	1	7	Planet	1890		616t, 68.9x8.1x2.4m, 4b,2vte, 4000hp, 23kts, 86p; 1x1-66/37, 6x1-47/40, (1+1x1)-450TT
	Trabant	1	8	Trabant	1890		
	Satellit	1	9	Satellit	1893		

	Magnet	1	10	Magnet		1896		510t, 67.5ppx8.2x3.3m, 4b,2vte, 6000hp, 26kts, 80p; 6x1-47/40, 2x1-450TT
TB	I	1	1	I		1875		10t, 20.7x2.6x1.2m, 1b,1vse, 184hp, 18kts, 9p; 1x1-37/20
	XI	12	2-13	XI, XII, XV-XVIII, XX-XXIV, XXVI		1884-1886		55t, 34.3x3.8x1.7m, 1b,1vc, 600hp, 18-19kts, 16p; 2x1-37/20(2-6,12,13), 1x1-37/20(7-11), 2-356TT(7-11)
	Adler	2	14	Adler		1886		100t, 41.2x4.2x1.7m, 2b,1vc, 1300hp, 22kts, 16p; 2x1-37/20, 2-356TT
			15	Falke		1886		
	Sperber	2	16, 17	Sperber, Habicht		1886		93t, 39.9x4.8x1.9m, 1b,1vte, 970hp, 18.5kts, 16p; 2x1-37/20, 2-356TT
	Bussard	20	18-37	Bussard, Condor, Geier, Uhu, Würger, Kranich, Reiher, Ibis, Rabe, Elster, Kukuk, Staar, Krähe, Flamingo, Sekretär, Weihe, Marabu, Gaukler, Harpie, Kibitz		1886-1891		88t, 39.9x4.8x1.9m, 1b,1vte, 1000hp, 19kts, 16p; 2x1-37/20, (1+1x1)-356TT
	XXVII	2	38, 39	XXVII, XXXII		1886-1888		55t, 34.3x3.8x1.7m, 1b,1vc, 600hp, 18-19kts, 16p; 1x1-37/20, 2-356TT(39)
	XXXIII	1	40	XXXIII		1887		70t, 36.8x4.5x1.9m, 1b,1vc, 700hp, 17kts, 16p; 2x1-37/20, 2-356TT
	XXXIV	6	41-46	XXXIV-XXXIX		1889-1891		64t, 36.9x4.8x1.9m, 1b,1vc, 750hp, 20.3kts, 16p; 2x1-37/20, (1+1x1)-356TT
	Natter	1	47	Natter		1896		166t, 47.3x5.3x2.8m, 2b,1vte, 2200hp, 24kts, 21p; 2x1-47/30, 3x1-450TT
Viper	1	48	Viper		1896		124t, 45.0x4.5x2.3m, 2b,1vte, 1900hp, 25kts, 21p; 2x1-47/30, 3x1-450TT	
Boa	4	49	Boa		1898		132t, 46.6x4.7x2.3m, 2b,1vte, 2000hp, 24.5kts, 21p; 2x1-47/30, 3x1-450TT	
		50	Cobra		1898			
		51	Python		1899			
		52	Kigyo		1900			

ESCORTS

AY	-	1	1	Dalmat	1896	260t
----	---	---	---	--------	------	------

OTHER FIGHTING SHIPS

PG	Albatros	2	1	Albatros	1874	No picture	570t, 46.0x8.3x3.4m, 400hp, 10kts, 99p; 2x1-149/24, 1x1-83/17
			2	Nautilus	1874		
	Leitha	2	1	Leitha	1872		315t, 50.6x8.1x1.1m, 2b,2vte, 700hp, 8kts, 59p; steel- 44side, 25deck, 50CT; 1x1-120/33, 2x1-47/40
			2	Maros	1872		

RMON	Körös	2	3	Körös	1892		448t, 54.0x9.0x1.2m, 2b,2vte, 1200hp, 10kts, 72p; 50side, 19deck, 75(3)-50(4)CT; 2x1-120/31, 2x1-66/37
			4	Szamos	1892		
	Temes	2	5	Temes	1904		
			6	Bodrog	1904		

COASTAL FORCES

YPR	A	1	1	A	1895	No picture	33t, 22.0x3.5x1.1m, 200hp
-----	---	---	---	---	------	------------	---------------------------

MINE WARFARE SHIPS

ML	Dromedar	1	1	Dromedar	1891	No picture	175t, 32.0x5.4x1.9m, 1b,1vte, 350hp, 10kts, 25p; 2x1-47/30, 50mines
	Salamander	1	2	Salamander	1892	No picture	286t, 39.6x8.1x1.5m, 1b,1vte, 350hp, 10kts, 28p; 2x1-47/30, 90mines
	Basilisk	1	3	Basilisk	1903	No picture	314t, 46.0x7.9x1.5m, 1b,1vte, 550hp, 11kts, 40p; 2x1-47/40, 145mines



[home](#)

[World navies yesterday](#)

[1905](#)

Belgium 01 January 1905

ESCORTS

FPV	Ville d'Anvers	1	1	Ville d'Anvers	1886	No picture	684t, 65.2x9.1x3.6m, 45p
-----	----------------	---	---	----------------	------	------------	--------------------------

© Ivan Gogin, 2015

[home](#)[World navies yesterday](#)[1905](#)

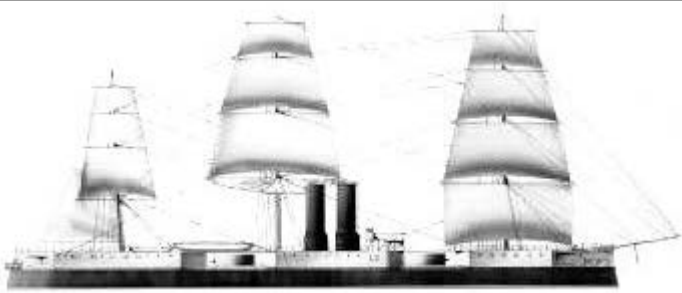
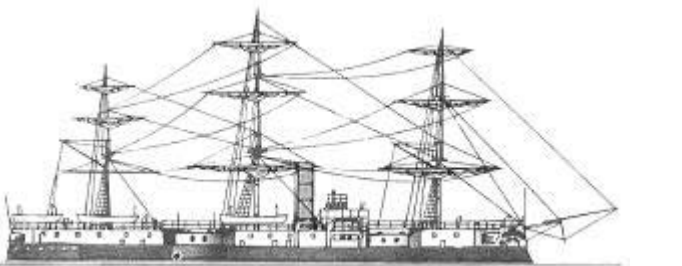
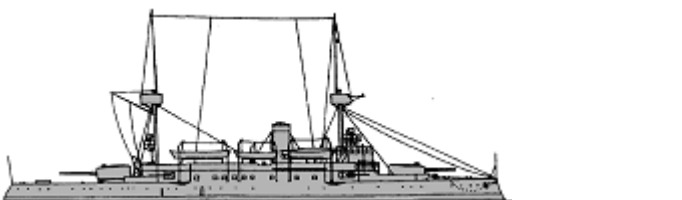

Brazil 01 January 1905

BATTLESHIPS

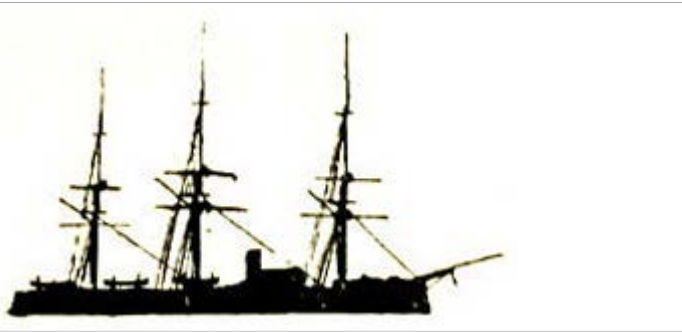

BB	Riachuelo	1	1	Riachuelo	1883		6100t, 93.0ppx15.9x6.0m, 10b,2vc, 7300hp, 16.7kts, 367p; compound- 292belt, 254turrets, 254CT; 2x2-234/31, 6x1-120/32, 6x1-47/40, 5-356TT
	Aquidabã	1	2	Aquidabã	1887		4921t, 85.3x15.9x5.6m, 8b,2ic, 6500hp, 15.8kts, 277p; compound- 292belt, 254turrets, 254CT; 2x2-234/31, 4x1 - 120/40, 10x1-57/42, 3-356TT
BC	Marshal Deodoro	2	1	Marshal Deodoro	1900		3162t, 81.5x14.4x4.2m, 8b,2vte, 3400hp, 15kts, 200p; Harvey- 350belt, 45deck, 220turrets, 125CT; 2x1-234/45, 4x1-120/50, 6x1-57/40, 2-450TT
			2	Marshal Floriano	1901		

CRUISERS

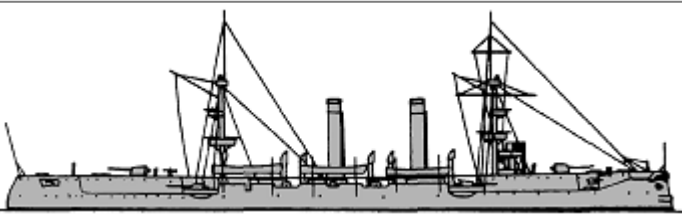
	Guanabara	1	1	Paysandú	1879	No picture	1914t, 61.0ppx12.6x5.4m, 1hse, 3000hp, 13kts, 287p; 9x1-127/24, 2x1-76/23, 1 spar torpedo
	Almirante Tamandaré	1	2	Almirante Tamandaré	1893		4735t, 89.7x14.4x6.0m, 7b,2hte, 7500hp, 17kts, 400p; steel- 40deck, 76casemates, 51CT; 10x1-152/40, 2x1-120/40, 10x1-47/40

CL	Benjamin Constant	1	3	Benjamin Constant	1894		2820t, 74.0x13.6x5.6m, 2vte, 4000hp, 15kts, 216+184p; 51deck, 95CT; 4x1-152/40, 8x1-120/40, 2x1-76/40, 2x1-37/20, 2x5-37/17, 4-450TT
	República	1	4	República	1894		1300t, 64.0ppx10.7x3.9m, 2hte, 3800hp, 17.4kts, 160p; steel- 51slopes, 25deck; 6x1-120/40, 4x1-57/40, (1+2x1)-356TT
	Almirante Barroso	1	5	Almirante Barroso	1897		3437t, 108.0x13.3x5.2m, 4b,2vte, 7500hp, 20.2kts, 366p; 88slopes, 31deck, 102CT; 6x1-152/50, 4x1-120/50, 10x1-57/40, 4x1-37/20, 3-450TT
CLL	Trajano	1	1	Tonelero	1873	No picture	1392t, 61.0ppx10.5x4.7m, 1hc, 2400hp, 11kts, 206p; 6x1-127/24
	Parnaíba	1	2	Parnaíba	1878	No picture	742t, 52.5ppx8.9x3.5m, 1hse, 900hp, 11.5kts, 149p; 6x1-127/24
	Primeiro de Março	1	3	Primeiro de Março	1881	No picture	750t, 50.8ppx8.4x3.5m, 1hc, 750hp, 8.5kts, 142p; 4x1-57/40, 2x1-37/20

TORPEDO SHIPS

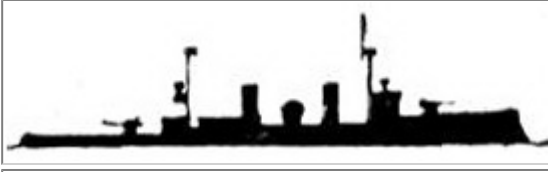
PGT	Tiradentes	1	1	Tiradentes	1893		795t, 50.3ppx9.1x3.3m, 2vte, 1646hp, 14.5kts, 110p; steel- 25CT; 4x1-120/40, 3x1-57/40, 2x1-356TT
	Gustavo Sampaio	1	2	Gustavo Sampaio	1893		480t, 60.0ppx6.1x2.6m, 2vte, 2000hp, 18kts, 60p; steel- 19CT; 2x1-89/40, 4x1-47/40, (1+2x1)-356TT
	Tupi	2	3	Tupi	1897		1014t, 76.1x9.4x3.1m, 2vte, 7000hp, 22.5kts, 110p; steel- 13deck, 114shields, 25CT; 2x1-120/37, 6x1-57/37, 2x1-37/37, (1+2x1)-356TT
			4	Timbira	1897		
Tamoio	1	5	Tamoio	1900		1063t, 82.0x8.8x3.0m, 2vte, 6500hp, 23kts, 110p; steel- 13deck, 114shields, 25CT; 2x1-120/37, 6x1-57/37, 2x1-37/37, (1+2x1)-356TT	
			1-				

TB	Núm.1	5	5	Núm.1-5	1882	No picture	40(1)-52(2-5)t, 30.5(1)-33.5(2-5)x3.8x1.7m, 1b,1vc, 500hp, 20(1)-20.4(2-5)kts; 1x1-37/20, 2-356TT
	Alpha	3	6-8	Alpha, Beta, Gamma	1885-1886	No picture	4t, 13.7x1.8x0.4m, 1b,1vse, 12.3kts; 1spar torpedo
	Araguari	3	9	Araguari	1893	No picture	110t, 45.7x4.4x1.1m, 2b,1vte, 1800hp, 25kts, 27p; 2x1-47/42, (1+2x1)-381TT
			10	Marcílio Dias	1893		
			11	Iguatemi	1893		
	Panne	5	12	Panne	1892		130t, 46.3x5.3x2.4m, 2b,2vte, 2200hp, 26kts, 24p; 2x1-37/37, (1+2x1)-356TT
			13	Pedro Affonso	1892		
			14	Pedro Ivo	1892		
			15	Pernambuco	1892		
			16	Silvado	1892		
Moxotó	1	17	Moxotó	1893	No picture	17t, 18.3x2.8x1.2m, 1b,1vc, 230hp, 16kts; 2x1-37/20, 1-340TT	

OTHER FIGHTING SHIPS



RMON	Pará	1	1	Rio Grande	1867		490t, 39.0x8.5x1.5m, 2b,2hda, 180hp, 8kts, 43p; iron- 102belt, 13deck, 152turret; 1x1-163/23 or 1x1-127/24
PGR	Yutohy	2	1, 2	Yutohy, Teffé	1892	No picture	33t, 27.4ppx4.6x1.5m, 11kts; 1x1-47/40

© Ivan Gogin, 2015

[home](#)[World navies yesterday](#)[1905](#)

Bulgaria 01 January 1905

TORPEDO SHIPS

PGT	Nadezhda	1	1	Nadezhda	1898		715t, 67.0x8.3x3.1m, 4b,2vte, 2600hp, 18kts, 97p; 2x1-100/45, 2x1-65/50, 2x1-47/40, 2x1-381TT
TB	Vasil Levski	2	1, 2	Vasil Levski, Khristo Botev	1877-1878		20t, 18.3x2.3x1.1m, 1b,1vc, 220hp, 13kts, 9p

© Ivan Gogin, 2015

[home](#)

[World navies yesterday](#)

[1905](#)

Cambodia 01 January 1905

OTHER FIGHTING SHIPS



PG	Lutin	1	1	Lutin	1877		492t, 44.1x7.3x3.3m, 2b,1hc, 440hp, 11kts, 76p; 2x1-139/21, 2x1-90/36, 4x5-37/17
----	-------	---	---	-------	------	---	--

© Ivan Gogin, 2015

[home](#)[World navies yesterday](#)[1905](#)

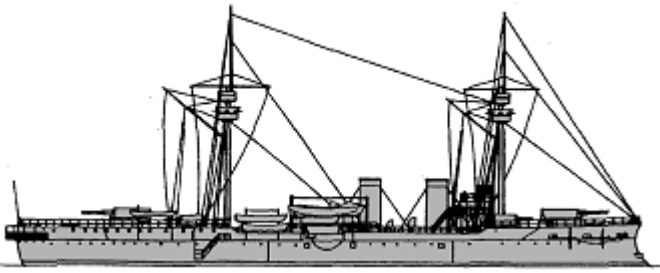

Chile 01 January 1905

BATTLESHIPS

BB	Capitán Prat	1	1	Capitán Prat	1893		6901t, 100.0ppx18.5x7.0m, 5b,2hte, 12000hp, 18.3kts, 480p; steel- 300belt, 50deck, 275barbettes, 265CT; 4x1-240/36, 4x2-120/45, 6x1-57/40, 4x1-47/40, 10x1-37/20, 4-450TT
BC	Cochrane	1	1	Cochrane	1874		3560t, 64.0ppx13.9x6.7m, 6b,2hte, 4300hp, 13.6kts, 300p; iron- 229belt, 203battery, 76CT; 6x1-203/30, 3x1-57/40, 6x1-37/20, 3-356TT
MON	Huascár	1	1	Huascár	1866		2030t, 57.9ppx10.7x5.6m, 4b,1hse, 1650hp, 12.3kts, 170p; iron- 114belt, 203turret, 76CT; 1x2-203/26, 2x1-57/40, 2x5-37/17

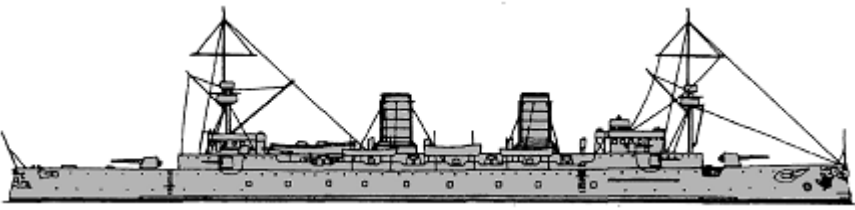

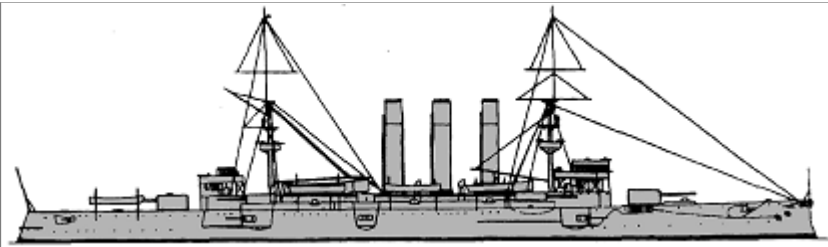
CRUISERS

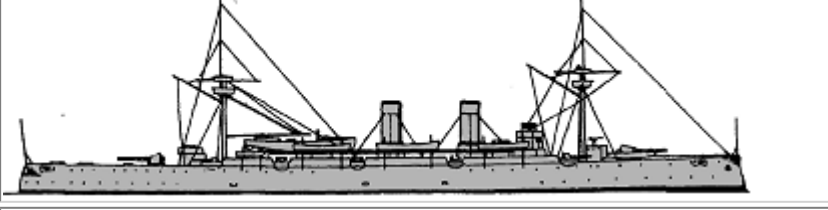
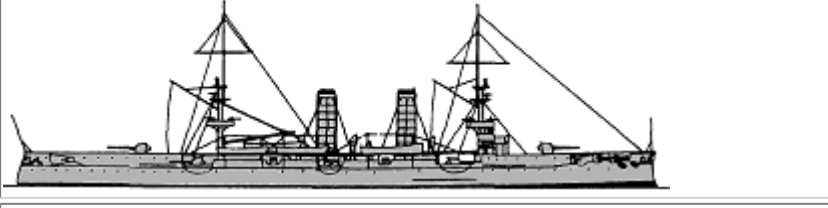
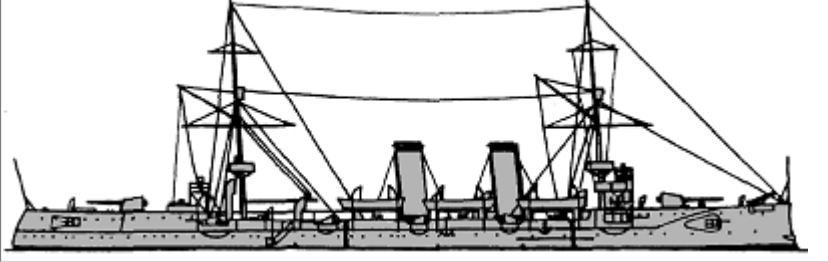
CA	Esmeralda	1	1	Esmeralda	1896		7000t, 132.9ppx16.2x6.2m, 12b,2vte, 16000hp, 22.2kts, 500p; Harvey- 152belt, 51deck, 114shields, 203CT; 2x1-203/40, 16x1-152/40, 8x1-76/40, 3-450TT
	O'Higgins	1	2	O'Higgins	1898		8500t, 135.2x19.1x6.7m, 30b,2vte, 16000hp, 21kts, 500p; Harvey- 178belt, 51deck, 178turrets, 229CT; 4x1-203/40, 10x1-152/40, 4x1-120/44, 10x1-76/40, 10x1-57/40, 3-450TT

							
CL	Presidente Errázuriz	1	Presidente Errázuriz	1892		2047t, 81.8ppx10.9x4.4m, 4b,2hte, 5400hp, 18.3kts, 170p; steel- 60slopes, 35deck, 90shields, 50CT; 4x1-150/36, 2x1-120/36, 4x1-57/40, 3-356TT	
		2	Presidente Pinto	1892			
	Blanco Encalada	1	3	Blanco Encalada	1894		4568t, 112.8ppx14.2x5.6m, 8b,2vte, 14600hp, 22.8kts, 427p; steel- 102slopes, 44deck, 152shields, 152CT; 2x1-203/40, 10x1-152/40, 12x1-76/40, 12x1-37/20, 5-450TT
	Ministro Zenteno	1	4	Ministro Zenteno	1898		3437t, 100.6ppx13.3x5.1m, 8b,2vte, 7500hp, 20.2kts, 317p; steel- 89slopes, 32deck, 102CT; 8x1-152/45, 10x1-57/40, 4x1-37/20, 3-450TT
	Chacabuco	1	5	Chacabuco	1902		4877t, 127.5x14.2x5.2m, 8b,2vte, 15700hp, 23kts, 400p; Harvey- 114slopes, 44deck, 114shields, 76CT; 2x1-203/45, 10x1-120/40, 12x1-76/40, 6x1-47/40, 3-450TT

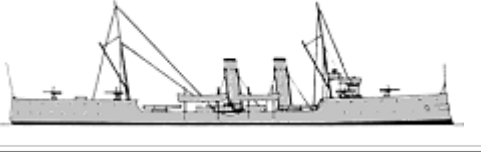
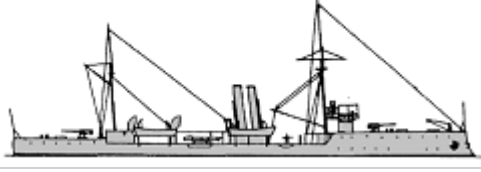
TORPEDO SHIPS

PGT	Almirante Lynch	1	Almirante Lynch	1890		713t, 70.1ppx8.4x2.5m, 4b,2vte, 4275-4532hp, 20.3-20.6kts, 87p; steel- 25deck; 6x1-57/50, (1+4x1)-356TT
		2	Almirante Condell	1890		
	Almirante Simpson	1	3	Almirante Simpson	1896	
		1	Capitán Orella	1896		

DD	Capitán Orella	4	2	Capitán Muñoz Gamero	1896		300t, 64.9ppx6.6x1.8m, 4b,2vte, 6250hp, 30kts, 65p; 1x1-76/40, 5x1-57/40, 2x1-450TT
			3	Teniente Serrano	1896		
			4	Guardiamarina Riquelme	1896		
	Capitán Merino Jarpa	3	5	Capitán Merino Jarpa	1902		
6			Capitán O'Brien	1902			
7			Capitán Thomson	1902			
TB	Sargente Aldea	1	1	Sargente Aldea	1886	No picture	80t, 38.1x4.0x2.1m, 1b,1vc, 700hp, 20kts, 16p; 2x2-25/42, 2-356TT
	Ingeniero Hyatt	6	2	Cirujano Videla	1896		140t, 46.5x4.7x2.4m, 2b,1vte, 2200hp, 27kts, 16p; 3x1-47/40, (1+1x2)-356TT
			3	Ingeniero Mery	1896		
			4	Ingeniero Hyatt	1896		
			5	Teniente Rodriguez	1896		
			6	Ingeniero Mutilla	1898		
			7	Guardiamarina Contreras	1898		

OTHER FIGHTING SHIPS



PG	Magallanes	1	1	Magallanes	1874	No picture	950t, 61.0x9.1x3.5m, 2hc, 1040hp, 11kts, 200p; 1x1-178/14, 1x1-161/14, 2x1-95/16
	Pilcomayo	1	2	Pilcomayo	1875	No picture	800t, 55.4ppx7.5x3.5m, 1hc, 1080hp, 11kts, 130p; 2x1-147/21, 2x1-121/22

© Ivan Gogin, 2015

[home](#)[World navies yesterday](#)[1905](#)

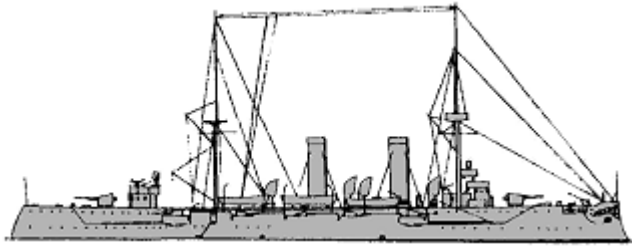
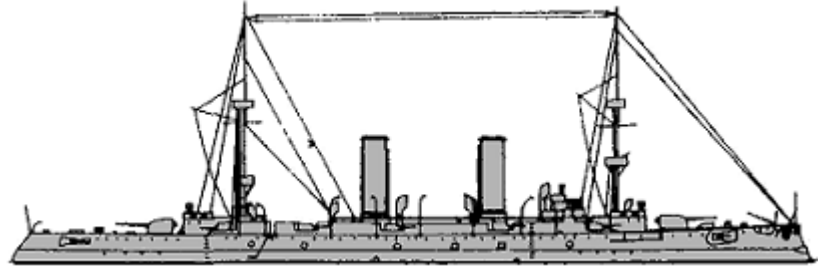

China 01 January 1905

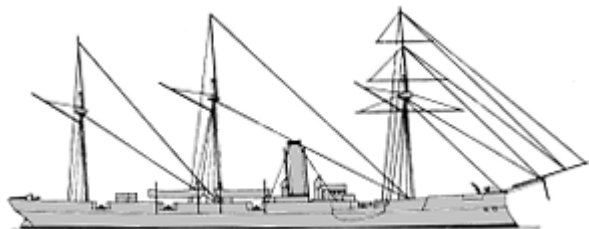
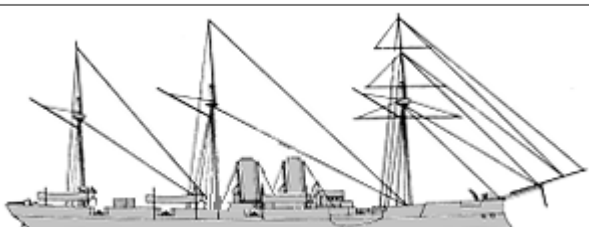
CRUISERS

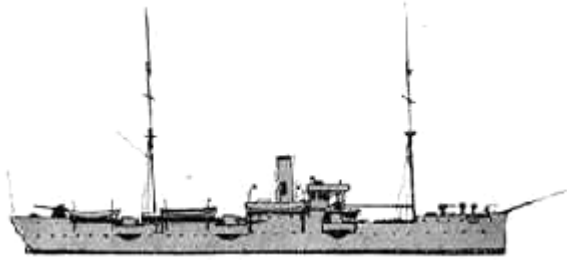
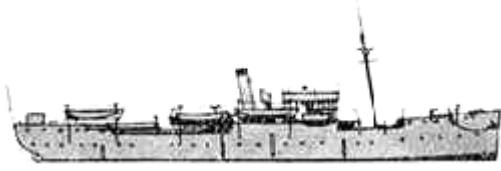
CL	Hai Yung	1	Hai Yung	1898		2950t, 100.0x12.4x5.8m, 8b,2vte, 7500hp, 19.5kts, 244p; 70slopes, 32deck, 51shields, 37CT; 3x1-149/37, 8x1-105/37, 6x1-47/37, 3-356TT
		2	Hai Chou	1898		
3		Hai Chen	1898			
	Hai Chi	1	Hai Chi	1899		4515t, 129.2x14.2x5.5m, 12b,4vte, 17000hp, 24kts, 350p; Harvey- 127slopes, 37deck, 114turrets, 152CT; 2x1-203/45, 10x1-120/45, 16x1-47/40, 5-450TT
CLL	Wei Yuen	1	Wei Yuen	1877		1258t, 66.2x9.0x3.8m, 750hp, 11kts, 180p; iron- 32shields; 1x1-160/14(1,3), 2x1-152/26(2), 6x1-121/22(1,3), 7x1-121/22(2)
		2	Chao Wu	1879		
		3	Kang Chi	1880		
	Kai Che	1	King Ch'ing	1886		2100t, 76.2x11.0x5.5m, 8b,1hte, 2400hp, 16kts, 300p; steel- casemates; 3x1-178/26, 7x1-121/22, 2-356TT
	Nan Thin	5	Nan Thin	1884		2200t, 84.0x11.0x5.5m, 8b,1hc, 2400hp, 15kts, 250p; 2x1-209/20, 8x1-120/32, 10x4-25/42, 1-356TT
		6	Nan Shui	1884		

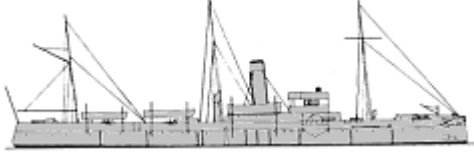
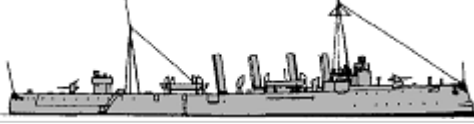
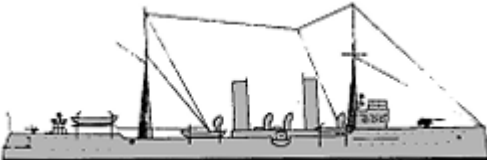

	Tung Chi	1	7	Tung Chi	1896		1900t, 77.0ppx10.4x4.9m, 4b,1vc, 1600hp, 11.6kts, 335p; 2x1-152/40, 5x1-120/45, 3x1-57/40, 8x1-37/20
	Fu An	1	8	Fu An	1897		1700t, 76.8ppx11.6x5.5m, 4b,1vc, 1600hp, 10kts, 105p; 2x1-57/40

TORPEDO SHIPS

PGT	Kuang Ping	1	1	Fu Ch'ing	1894		1000t, 71.6x8.2x4.0m, 3b,2hte, 2400hp, 16kts, 120p; steel- 25deck, 51CT; 3x1-120/32, 4x1-47/40, (2+2x1)-356TT
	Fei Ying	1	2	Fei Ying	1896		850t, 75.0x8.6x4.0m, 8b,2vte, 5430hp, 22kts, 90p; 25deck, 50shields; 2x1-105/37, 6x1-57/40, 4x1-37/20, (1+2x1)-356TT
	Chien Wei	2	3	Chien Wei	1903		900t, 79.2x8.1x3.5m, 4b,2vte, 6500hp, 20.5kts, 140p; steel- 25belt, 25deck; 1x1-100/44, 3x1-65/50, 6x1-37/27, 2x1-356TT
4			Chien An	1903			
TB	Lei Fu	2	1, 2	Lei Fu, Lei Lung	1884	No picture	64t, 35.0x4.0x1.7m, 2b,1vte, 700hp, 19.8kts, 20p; 2x5-37/17, 2-356TT
	Lei Chen	9	3-11	Lei Chen, Lei Chung, Lei Kong, Lei Kwong, Lei Kung, Lei Li, Lei Sun, Lei Tsen, Lei Tui	1885	No picture	27t, 26.0x3.6m, 1b,1vc, 420hp, 19.5kts; 1-356TT
	Chang Tze	2	12, 13	No1 Chang Tze, No3 Lieh Tze	1895	No picture	89t, 39.0x4.8x1.5m, 1b,1vc, 600hp, 18kts, 31p; 2x5-37/17, (2+1x1)-356TT
	Chen Tse	2	14	No2 Chen Tse	1896		126t, 43.9x5.2x2.4m, 2b,1vte, 1000hp, 18kts, 31p; 2x5-37/17, (2+1x1)-450TT
15			No4 Su Tse	1896			

OTHER FIGHTING SHIPS

Kwangtung	2	1	An Lan	1868	No picture	440t, 42.7x7.2x2.7m, 3b,1hr, 255hp, 9.3kts, 60p; 1x1-178/16, 2x1-121/22
		2	Chen T'ao	1868		
Chen Hai	2	3	Chen Hai	1872	No picture	578t, 49.0x8.0x3.2m, 2b,1hse, 480hp, 10kts, 70p; 2x1-160/16(3), 1x1-160/16(4), 4x1-121/22
		4	Ching Yuan	1873		
		5	Fei Ting	1876		

PG	Fei Ting	2	6	Tse Tien	1876		420t, 36.6x9.1x2.4m, 1b,2hcr, 270hp, 9.5kts, 30p; iron- 13shield, 13CT; 1x1-318/16, 2x1-70/22, 1x4-25/42
	Hai Ch'ang Ch'ing	1	7	Hai Ch'ang Ch'ing	1877		430t, 38.1x9.1x2.4m, 1b,2hcr, 70hp, 7.5kts; 1x1-279/12, 2x1-76/28
	Kuang Yuan	4	8	Kuang Yuan	1886	No picture	300t, 33.8x5.5x2.3m, 2hcr, 65-78hp, 9-10kts; 1x1-149/32, 1x1-88/32, 3x1-37/42
			9	Kuang Heng	1886		
			10	Kuang Li	1886		
			11	Kuang Chien	1886		
	Kuang Keng	4	12	Kuang Keng	1887	No picture	560t, 43.0x7.3x3.7m, 1vr, 400hp, 11kts; 2x1-121/22, 1x1-100/22, 2x1-47/40
13			Kuang Hsing	1887			
14			Kuang Jen	1887			
15			Kuang Kuei	1887			
Chen Sheng	1	16	Chen Sheng	1899	No picture	275t, 36.6x6.1x2.1m, 1vc, 400hp, 10kts, 42p; 1x1-76/40, 1x1-57/40	

CUSTOMS FLOTILLAS

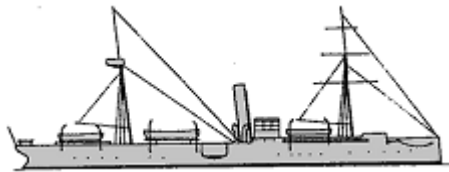
CGC	Ping Ching	1	1	Ping Ching	1880	No picture	1000t, 64.7x9.2m, 1x1-160/16, 4x1-109/17, 1x1-88/22
	Fee Cheu	1	2	Fee Cheu	1887		1300t, 67.1x9.8x4.0m, 13kts; 2x1-152/26
	Chuen Tiao	1	3	Chuen Tiao	1888	No picture	716t, 47.3x7.6x3.5m, 10kts; 2x1-95/21, 2x1-47/40
	Likin	2	4	Likin	1888	No picture	512t, 41.2x7.0x3.5m, 10kts; 2x1-95/21, 2x1-47/40
			5	Kaipan	1888		
	Liu Hsing	1	6	Liu Hsing	1902	No picture	1500t, 59.2x8.4m

© Ivan Gogin, 2015

[home](#)[World navies yesterday](#)[1905](#)

Colombia 01 January 1905

CRUISERS

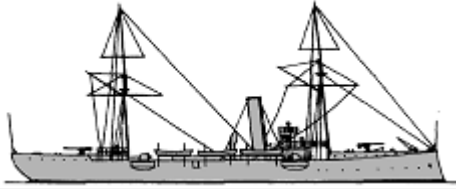
CLL	Almirante Lezo	1	1	Almirante Lezo	1892		1200t, 70.0x10.0x2.6m, 1vte, 2500hp, 18kts, 150p; 2x1-120/40, 4x1-37/25, 4-356TT
-----	----------------	---	---	----------------	------	--	--

OTHER FIGHTING SHIPS

PG	Boyacá	1	1	Boyacá	1883	No picture	
	La Popa	1	2	La Popa	1887	No picture	
APG	-	5	1	Chiquito			
			2	Clapet	1880s		
			3	Hércules			
			4	Marquin			
			5	Bogotá	1884		676t
PGR	General Pinzón	1	1	General Pinzón	1881	No picture	740t, (stw), 13kts; 3x1-37/20
	Esperanza	2	2	Esperanza	1897	No picture	400t, 42.4ppx5.8x0.9m, (stw), 430hp, 15kts; 3x1-37/20
			3	General Nerín	1895		
	Chercinto	1	4	Chercinto	1896	No picture	643t, 56.4x9.4x3.7m, 400hp, 12kts; 3x1-37/20
APGR	-	1	1	Bolívar	1870		981t

© Ivan Gogin, 2015

[home](#)

[World navies yesterday](#)

[1905](#)

Costa Rica 01 January 1905

TORPEDO SHIPS

TB	no name	1	1	no name	1890	No picture	15t, 18.3x2.8x1.1m, 1b,1vte, 230hp, 17kts; 1x1-47/40, 1-356TT
----	---------	---	---	---------	------	------------	---

© Ivan Gogin, 2015

[home](#)[World navies yesterday](#)[1905](#)

Cuba 01 January 1905

COAST GUARD SHIPS

CGC	Veinte de Mayo	1	1	Veinte de Mayo	1895	No picture	203t, 45.7x5.6x3.2m, 500hp, 12kts, 43p; 2x1-47/40, 2x1-37/40
	Yara	1	2	Yara	1895	No picture	449t, 47.2x7.9x4.0m, 600hp, 12kts, 53p; 2x1-57/40, 2x1-47/40
	Alfredo	1	3	Alfredo	1896	No picture	40t, 18.3x3.7x1.8m, 11kts; 1x1-37/40
	Maceo	3	4-6	Maceo, Céspedes, Argamonte	1896	No picture	35t, 22.9x3.1x1.7m, 10kts; 1x1-37/40
	Enrique Villuendas	1	7	Enrique Villuendas	1899	No picture	178t, 40.2x6.1x2.7m, 600hp, 16kts; 2x1-47/40

© Ivan Gogin, 2015

[home](#)[World navies yesterday](#)[1905](#)

Denmark 01 January 1905

BATTLESHIPS

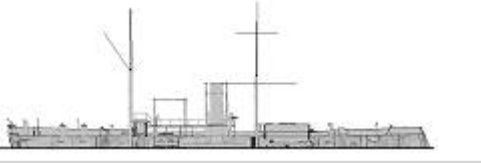
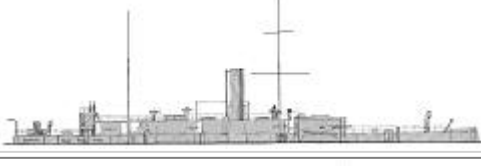
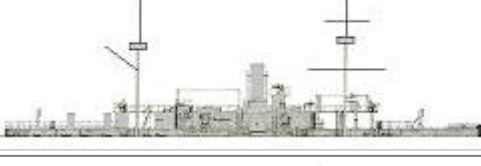
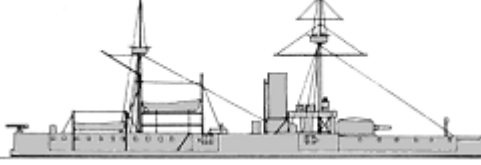
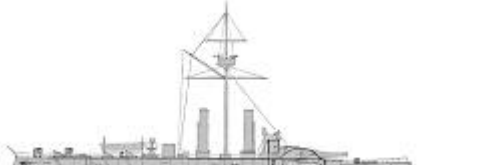

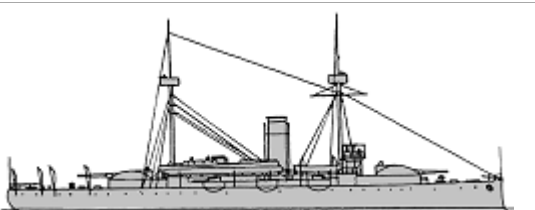
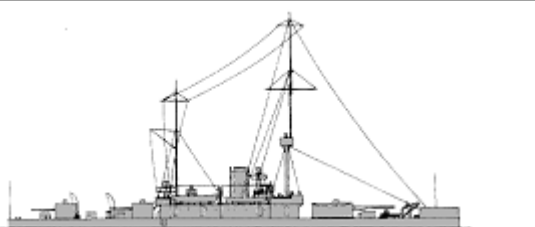
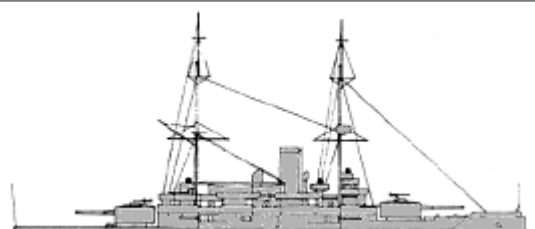



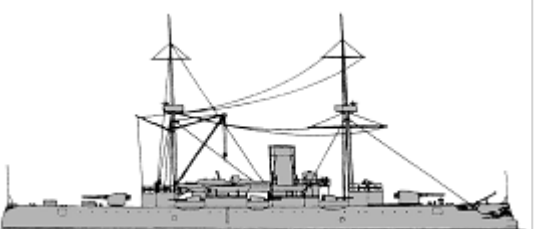
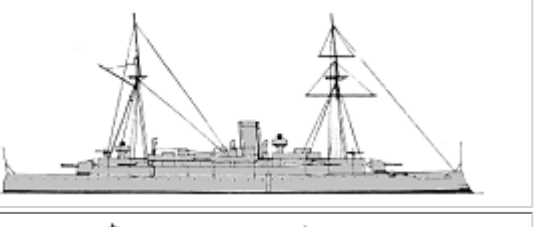
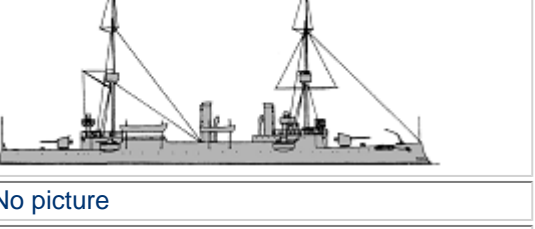



	Rolf Krake	1	1	Rolf Krake	1863		1320t, 57.0x11.6x3.2m, 4b,2hr-cr, 750hp, 9.5kts, 150p; iron- 114side, 114turrets; 2x1-203/13, 2x1-87/21, 4x5-37/17
	Lindormen	1	2	Lindormen	1869		2105t, 66.4x12.0x4.4m, 4b,2hr-cr, 1500hp, 12kts, 150p; iron- 127side, 140turret; 1x2-229/14, 4x1-87/21, 4x1-37/20
	Gorm	1	3	Gorm	1871		2350t, 71.7x12.2x4.4m, 4b,2hr-cr, 1600hp, 12.5kts, 160p; iron- 178side, 203turret; 1x2-149/32, 4x1-57/40, 4x5-37/17
	Odin	1	4	Odin	1874		3230t, 73.4ppx14.8x5.0m, 4b,2hr-cr, 2300hp, 12kts, 206p; compound- 203side, 203battery; 4x1-254/15, 4x1-87/21, 6x5-37/17
	Helgoland	1	5	Helgoland	1879		5332t, 79.1x18.0x5.9m, 8b,2hr-cr, 4000hp, 13.7kts, 331p; iron- 305belt, 254barbette; 1x1-305/19, 4x1-263/19, 4x1-120/22, 2x1-57/40, 3x1-37/20, 4x5-37/17, 2-381TT, 3-356TT
BC	Tordenskjold	1	6	Tordenskjold	1882		2462t, 67.8x13.2x4.8m, 8b,2vc, 2600hp, 12.7kts, 206p; compound- 97slopes, 38deck, 203barbette; 1x1-355/22, 4x1-120/22, 8x5-37/17, 1-381TT, 3-356TT
	Iver Hvitfeldt	1	7	Iver Hvitfeldt	1887		3478t, 74.5ppx15.1x5.6m, 8b,2vc, 5100hp, 15.2kts, 277p; compound- 295belt, 53deck, 215barbettes, 115CT; 2x1-263/32, 4x1-120/27, 2x1-57/40, 8x5-37/17, 2-381TT, 2-356TT

						
	Skjold	1 8	Skjold	1897		2195t, 69.4x11.6x4.2m, 4b,2vte, 2400hp, 14kts, 138p; Harvey- 229belt, 50deck, 250turret; 1x1-240/37, 3x1-120/38, 4x1-47/40
	Herluf Trolle	1 9	Herluf Trolle	1901		3650t, 86.5x15.1x5.0m, 6b,2vte, 4200hp, 15.5kts, 258p; steel- 195belt, 65deck, 175turrets, 190CT; 2x1-240/38, 4x1-149/42, 10x1-57/40, 8x1-37/20, 3-450TT

CRUISERS

	St. Thomas	1 1	St. Thomas	1872	No picture	1550t, 70.1x10.0x5.2m, 1800hp, 13kts, 182p; 1x1-203/13, 4x1-154/16, 1x1-84/13
	Valkyrien	1 2	Valkyrien	1890		3020t, 85.8x13.2x5.5m, 6b,2vte, 5200hp, 17kts, 282p; steel- 65deck; 2x1-209/32, 6x1-149/32, 4x1-57/40, 8x5-37/17, 5-381TT
CL	Hekla	1 3	Hekla	1891		1300t, 72.3x10.4x3.5m, 8b,2vte, 3000hp, 17kts, 156p; steel- 43deck; 2x1-149/32, 4x1-57/40, 6x5-37/17, 4-381TT
	Gejser	4	Gejser	1893		1282(4)-1342(5)t, 72.3x10.4x3.5m, 8b,2vte, 3000hp, 17kts, 156p; steel- 50(4)-45(5)deck; 2x1-120/38, 4x1-87/37, 2x1-37/20, 4x5-37/17, 1-450TT, 3-381TT
		5	Hejmdal	1895		
CLL	Ingolf	1 1	Ingolf	1878	No picture	1012t, 63.9x8.5x4.2m, 630hp, 10.2kts, 156p; 4x1-120/38, 4x5-37/17
	Fyen	1 2	Fyen	1884	No picture	2663t, 69.0ppx13.8x6.1m, 2600hp, 12.5kts, 300p; 14x1-149/22, 8x5-37/17, 2-356TT

TORPEDO SHIPS

TB1cl	Nr.6	1	1	Sværdfisken	1881		58t, 33.5x3.7x1.8m, 1b,1vc, 600hp, 17kts, 15p; 1x5-37/17, 2-381TT
	Delfinen	1	2	Delfinen	1883		66t, 33.6x3.6x0.7m, 1b,1vc, 670hp, 17kts, 15p; 1x5-37/17, 2-381TT
	Hvalrossen	1	3	Hvalrossen	1884		74t, 34.5x3.7x2.0m, 1b,1vc, 660hp, 17kts, 15p; 1x5-37/17, 2-381TT
	Støren	2	4	Støren	1887		107t, 39.7x4.2x2.2m, 2b,1vc, 1200hp, 18.5kts, 20p; 2x5-37/17, (2+1x2)-381TT
			5	Søløven	1887		
	Nahrvalen	2	6	Nahrvalen	1888		111t, 41.1x4.2x2.2m, 2b,1vc, 1200hp, 18.5kts, 20p; 2x5-37/17, (2+1x2)-381TT
			7	Havhesten	1888		
	Springeren	1	8	Springeren	1891		89t, 36.3x4.0x2.1m, 2b,1vc, 800hp, 17.5kts, 17p; 2x5-37/17, 2-450TT
	Nordkaperen	2	9	Nordkaperen	1893		127t, 42.5x4.3x2.2m, 2b,1vc, 1300hp, 19kts, 20p; 2x5-37/17, 2-450TT, 1x2-381TT
			10	Makrelen	1894		
Hajen	1	11	Hajen	1896		141t, 42.9x4.6x2.5m, 2b,2vte, 2000hp, 22kts, 25p; 1x1-47/40, 1x5-37/17, 2-450TT, 1x2-381TT	
Havørnen	2	12	Havørnen	1897		142t, 44.4x4.7x2.4m, 2b,2vte, 2 100hp, 22kts, 25p; 1x1-47/40, 1x5-37/17, (2+1x2)-450TT	
		13	Søbjørnen	1898			
TB2cl	Nr.4	1	1	Nr.2	1879		32t, 27.8x3.0x1.6m, 1b,1vc, 350hp, 15.5kts, 12p; 1x1-37/20, 1-356TT
	Nr.5	1	2	Nr.3	1880	No picture	37t, 29.0xxm, 1b,1vc, 450hp, 15kts; 1x1-37/20, 2-356TT
	P8	2	3, 4	P8, 9	1894-1895	No picture	48t, 25.6x3.8x1.8m, 1vte, 330hp, 13kts, 13p; 1x1-47/40, 1x5-37/17, 1x1-356TT
	Nr.10	1	5	P3	1878	No picture	14t, 14.6x2.8x1.2m, 1b,1hda, 10.5kts, 8p; 1x5-37/17
	Nr.4	1	6	Nr.4	1882	No picture	15t, 18.8x2.2x1.1m, 1b,1vc, 150hp, 13kts, 6p; 1x1-37/20, 2-356TT
	Nr.6	2	7, 8	Nr.6, 7	1884	No picture	15t, 20.1x2.4x1.3m, 1b,1vc, 150hp, 13kts, 6p; 1x1-37/20, 2-356TT
	Nr.8	2	9, 10	Nr.8, 9	1886	No picture	15t, 20.6x2.4x1.2m, 1b,1vc, 170hp, 13kts, 6p; 1x1-37/20, 2-356TT
	Nr.10	2	11, 12	Nr.10, 11	1888	No picture	17t, 21.0x2.4x1.2m, 1b,1vc, 180hp, 13.5kts, 6p; 1x1-37/20, 2-356TT
	Nr.12	2	13, 14	Nr.12, 13	1889	No picture	25t, 23.8x2.7x1.3m, 1b,1vc, 350hp, 15kts, 6p; 1x1-37/20, 2-356TT
	P4	4	15-18	P4-7	1889-1890	No picture	20t

OTHER FIGHTING SHIPS

PG	Absalon	2	1	Absalon	1862	No picture	533t, 47.8x7.9x3.3m, 500hp, 11kts, 50p; iron- 64belt; 2x1-120/27(1), 2x1-87/21(1), 2x5-37/17(2), 1-381TT(2), 1x1-356TT(2)			
			2	Esbern Snare	1862					
	Falster	1	3	Falster	1874		390t, 34.3x8.8x2.6m, 510hp, 10.5kts, 50p; 1x1-57/40, 6x5-37/17			
				Øresund	3	4	Øresund	1875	No picture	240t, 26.1x8.0x2.1m, 200hp, 7.5kts, 36p; 1x1-57/40, 6x5-37/17
						5	Store Bælt	1875		
	6	Lille Bælt	1876							
	Grønsund	2	7	Grønsund	1883	No picture	247(7)-268(8)t, 36.3x6.1x2.5m, 300(7)-400(8)hp, 10(7)-10.5(8)kts, 46-49p; 2x1-57/40(7), 2x1-47/40(8), 2x5-37/17(7)			
			8	Guldborgsund	1885					

BR	Ørnen	1	1	Ørnen	1880	No picture	300t
----	-------	---	---	-------	------	------------	------

MINE WARFARE SHIPS

ML	Hjælperen	1	1	Hjælperen	1891	No picture	288t, 38.3x6.8x2.3m, 330hp, 25p; 3x5-37/17, mines
----	-----------	---	---	-----------	------	------------	---

FISHING PROTECTION VESSELS

FPV	Beskytteren	1	1	Beskytteren	1900		415t, 43.4x7.6x3.8m, 2b,1vte, 625hp, 11kts, 47p; 1x1-47/40, 2x1-37/20
-----	-------------	---	---	-------------	------	--	---

Google
Custom Search

© Ivan Gogin, 2014

[home](#)[World navies yesterday](#)[1905](#)

Dominican Republic 01 January 1905

OTHER FIGHTING SHIPS

PG	El Presidente	1	1	El Presidente	1873	No picture	389t, 63.7x6.6m, 105hp, 13.8kts, 50p; 4x1-121/22
	Independencia	1	2	Independencia	1894	No picture	322t, 51.8x7.6m, 2vte, 15kts; 7x1-small guns
	Restauración	1	3	Restauración	1896	No picture	1000t, 65.2x9.1m, 2vte, 14kts; 4x1-120/40, 5x1-small guns

© Ivan Gogin, 2015

[home](#)[World navies yesterday](#)[1905](#)

Ecuador 01 January 1905

TORPEDO SHIPS

TB	Tungurahua	1	1	Tungurahua	1890s		65t
----	------------	---	---	------------	-------	---	-----

ESCORTS

AY	-	1	1	Cotopaxi	1884		300t; 4x1-76/40
----	---	---	---	----------	------	--	-----------------

OTHER FIGHTING SHIPS

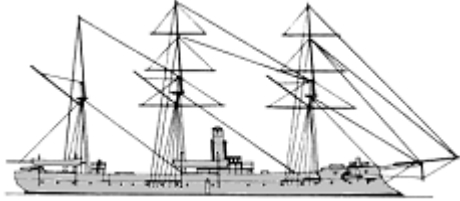

PG	Papin	2	1	Inconstant	1887		877t, 61.3x8.0x4.2m, 6b,1hc(1)-4b,1hc(2), 1100hp, 12kts, 116p; 3x1-139/30, 1x1-100/26, 5x5-37/17
			2	Papin	1887		
APG	-	2	1	Nueve de Julio			
			2	Patria			300brt

© Ivan Gogin, 2015

[home](#)[World navies yesterday](#)[1905](#)

Egypt 01 January 1905

ESCORTS

PC	Noor El Bahr	1	1	Noor El Bahr	1884		450t
	Nesim	1	2	Nesim	1885	No picture	81t
	Marda	1	3	Marda	1886	No picture	154t
	Zarif	1	4	Zarif	1886	No picture	144t
	Saria	1	5	Saria	1886	No picture	71t
	Abbas	1	6	Abbas	1891		298brt
APC	-	1	1	Abdul Monaym	1902		610t

OTHER FIGHTING SHIPS

PG	Khartum	1	1	Khartum	1862	No picture	455t
	Dongola	1	2	Dongola	1863	No picture	300t
	Jeafferieh	1	3	Jeafferieh	1865	No picture	690t
PGR	Tamai	4	1-4	Tamai, Hafir, Metemmeh, Abu Klea	1884-1885	No picture	74t, (stw); 1x1-76/40
	El Zafir	3	5	El Zafir	1896	No picture	128t, (stw); 1x1-76/40
			6	El Fateh	1897		
			7	El Nasir	1897		
	Sultan	3	8	Sheik	1896	No picture	140t; 1x1-76/40
			9	Sultan	1896		
			10	Melik	1897		

[home](#)

[World navies yesterday](#)

[1905](#)

El Salvador 01 January 1905

OTHER FIGHTING SHIPS

PG	Cuscatlan	1	1	Cuscatlan	1890	No picture	75t, 10kts; 1x1-small gun
----	-----------	---	---	-----------	------	------------	---------------------------

© Ivan Gogin, 2015

[home](#)[World navies yesterday](#)[1905](#)

France 01 January 1905

BATTLESHIPS

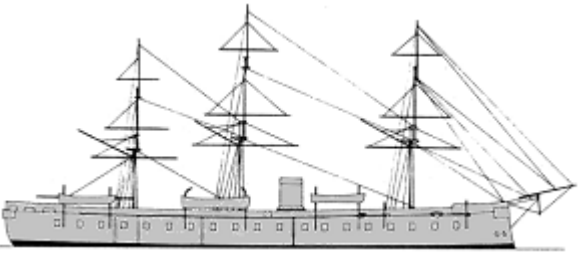
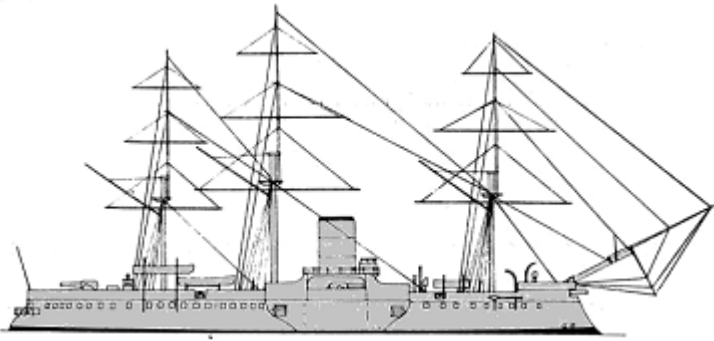
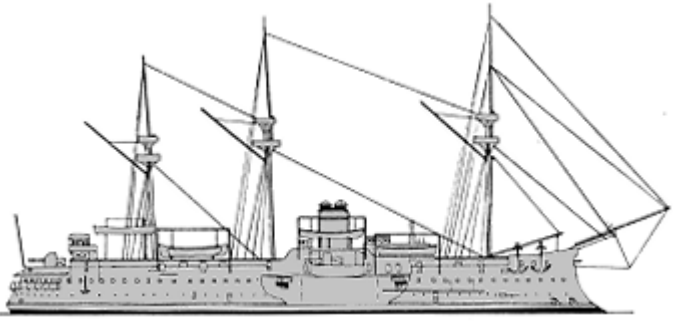
Couronne	1	1	Couronne	1862		5983t, 80.9x16.7x8.2m, 8b,1hrer, 2900hp, 13kts, 570p; iron- 120belt; 8x1-240/18, 4x1-194/20, 2x1-120/25, 12x5-37/20
Redoutable	1	2	Redoutable	1878		9224t, 100.7x19.7x7.8m, 8b,1vte, 6200hp, 14.7kts, 705p; iron- 350belt, 60deck, 300battery; 3x1-274/40, 1x1-274/29, 4x1-240/30, 6x1-100/45, 5x1-65/50, 14x1-47/40, (5x5+5x1)-37/20, 2-350TT
Courbet	2	3	Courbet	1886		10450t, 100.2x21.3x8.1(3)-8.2(4)m, 12b,2vc(3)-12b,2vte(4), 8300hp, 15(3)-15.5(4)kts, 689p; iron- 380belt, 60deck, 240battery; 4x1-340/18(3), 3x1-274/45(3), 4x1-274/20(4), 2x1-240/40(4), 6x1-139/28(3), 10x1-100/45(4), 4x1-65/50(3), 14x1-47/40(3), 14x1-47/40(4), (19x5+7x1)-37/20(3), 2x1-37/20(4), 5-350TT
		4	Dévastation	1882		
Amiral Duperré	1	5	Amiral Duperré	1883		11030t, 98.9x20.4x8.4m, 12b,2vc, 7300hp, 14kts, 660p; iron- 560belt, 60deck, 300barbettes, 40CT; 3x1-340/21, 5x1-165/28, 14x1-139/21, 2x1-65/50, 22x1-47/40, (18x5+18x1)-37/20, 4-350TT

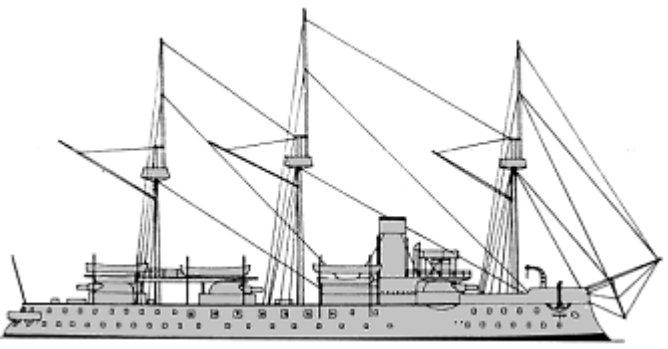
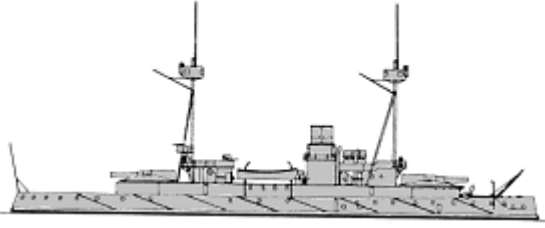
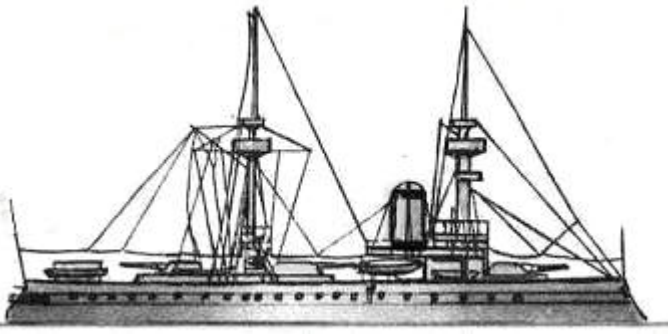
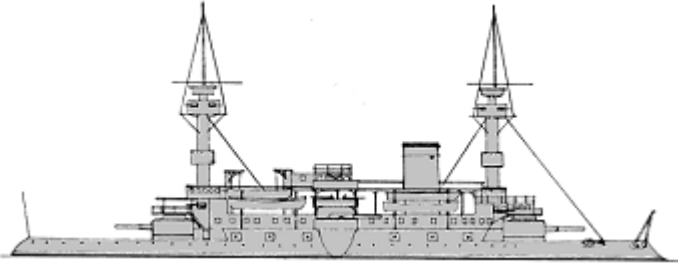
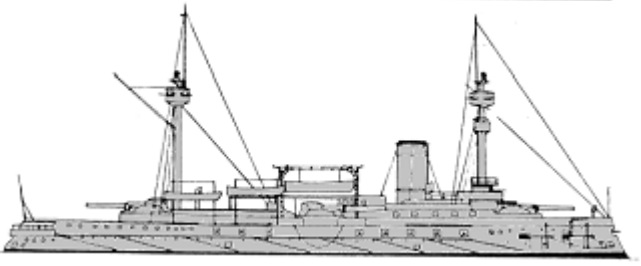
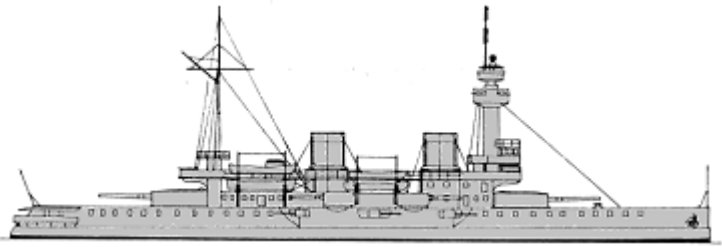
						
Terrible	4	6	Terrible	1887		7530t, 85.3x18.0x8.0m, 12b,2vc(6-8)-12b,2vte(9), 6500(6-8)-11200(9)hp, 14.5(6-8)-15(9)kts, 373p; steel(6)- compound(7-9)- 500belt, 105deck, 450barbettes, 30CT; 2x1-340/35(6), 2x1-274/40(7-9), 4x1-100/26(6), 6x1-100/45(7-9), 4x1-47/40(6), 14x1-47/40(7-9), 16x5-37/20(6), 4-350TT(6), 2-350TT(7,8)
		7	Indomptable	1887		
		8	Caïman	1888		
		9	Requin	1888		
Amiral Baudin	2	10	Amiral Baudin	1888		11720t, 101.0x21.3x8.5m, 12b,2vc, 8400(10)-9700(11)hp, 15(10)-16(11)kts, 625(10)-650(11)p; steel/compound- 550belt, 100deck, 400barbettes, 120CT; 2x1-370/28, 8x1-165/30, 8x1-139/45(10), 10x1-139/28(11), 2x1-65/50(10), 20x1-47/40(10), 1x1-47/40(11), 12x5-47/20(11), (2x5+6x1)-37/20(10), 18x5-37/20(11), 4-380TT
		11	Formidable	1889		
Hoche	1	12	Hoche	1890		10580t, 102.6x20.2x8.3m, 16b,2vte, 12000hp, 16.5kts, 611p; compound- 450belt, 100deck, 400turrets, 65CT; 2x1-340/29, 2x1-274/29, 12x1-139/45, 4x1-65/50, 10x1-47/40, 10x5-37/20, 3-380TT
Marceau	3	13	Marceau	1891		10558(13)-10810(14)-10680(15)t, 101.6x20.2(13)-20.0(14,15)x8.2-8.4m, 16b,2vc(13)-12b,2vc(14)-8b,2vc(15), 11000hp, 16kts, 643-651p; compound(13,14)-steel(15)- 450belt, 90deck, 400barbettes, 150CT; 4x1-340/29, 16x1-139/30(13), 17x1-139/30(14,15), 3x1-65/50(13), 6x1-65/50(14,15), 9x1-47/40(13), 18x1-47/40(14,15), 8x5-37/20(13), 12x5-37/20(14,15), 3-380TT(13), 5-380TT(14,15)
		14	Neptune	1892		
		15	Magenta	1893		
Brennus	1	16	Brennus	1896		11190t, 114.0x20.4x8.3m, 32b,2vte, 13900hp, 18kts, 673p; steel/compound- 450belt, 80deck, 450turrets, 150CT; (1x2+1x1)-340/42, 10x1-165/45, 4x1-65/50, 14x1-47/40, 8x1-37/20

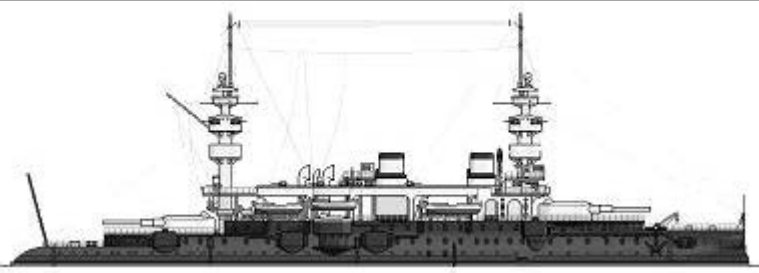
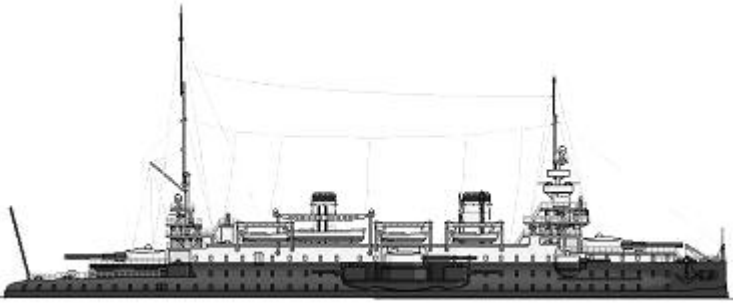
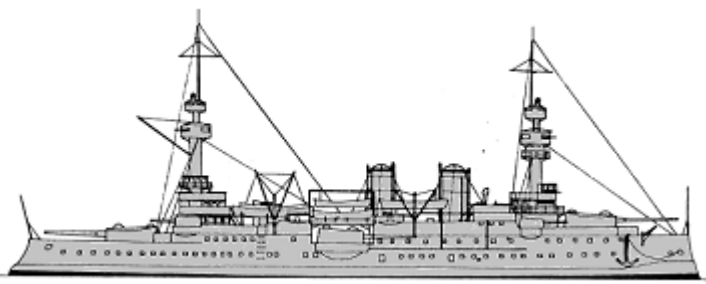
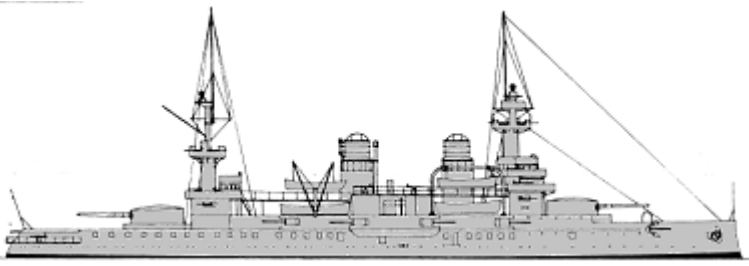
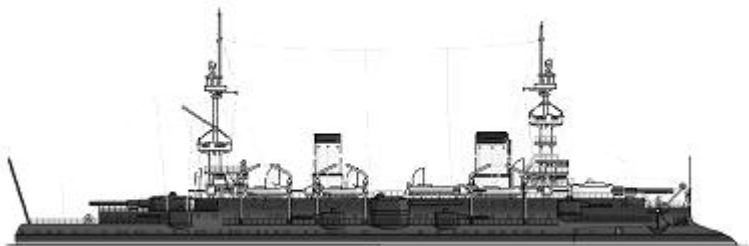
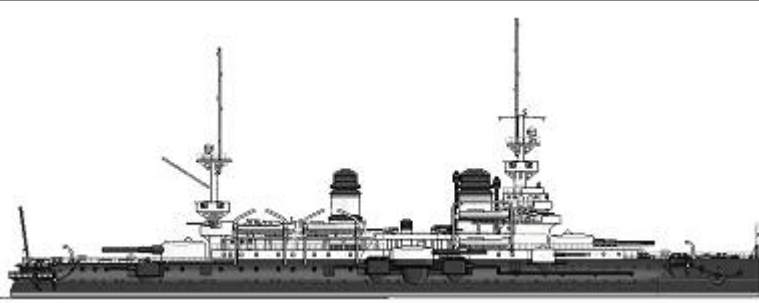

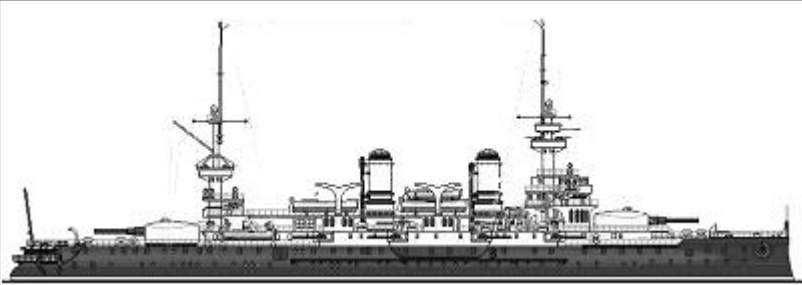
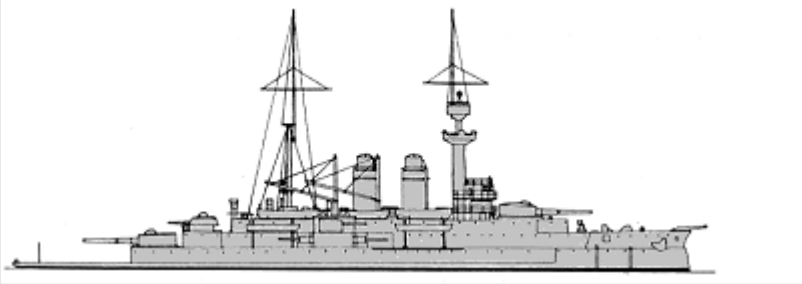
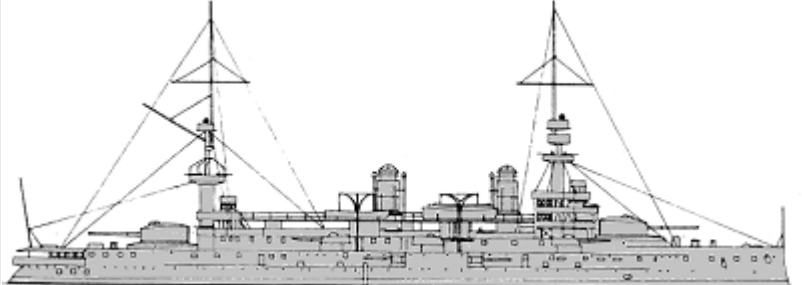
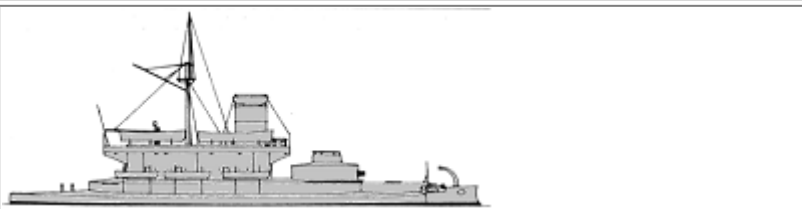
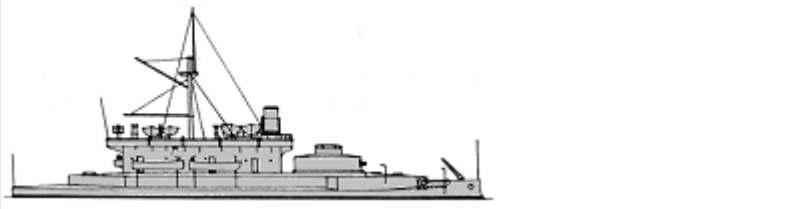
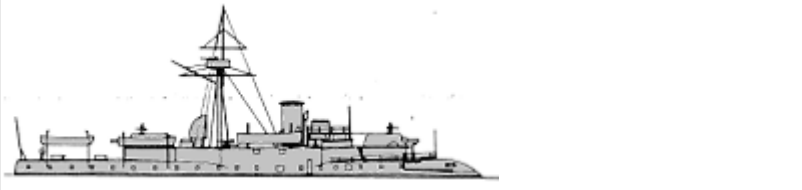
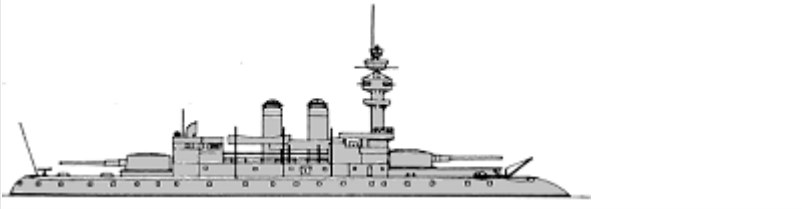
Charles Martel	1	17	Charles Martel	1897		11693t, 119.0x21.6x8.4m, 24b,2vte, 14900hp, 18kts, 644p; nickel steel- 450belt, 70deck, 380turrets, 230CT; 2x1-305/45, 2x1-274/45, 8x1-139/45, 4x1-65/50, 16x1-47/40, 8x5-37/20, 2-450TT
Carnot	1	18	Carnot	1897		11954t, 119.0x21.4x8.4m, 24b,2vte, 16300hp, 17.8kts, 647p; nickel steel- 450belt, 70deck, 380turrets, 230CT; 2x1-305/45, 2x1-274/45, 8x1-139/45, 4x1-65/50, 16x1-47/40, 8x5-37/20, 2-450TT
Jauréguiberry	1	19	Jauréguiberry	1897		11637t, 111.9x22.2x8.4m, 24b,2vte, 14400hp, 17.7kts, 631p; nickel steel- 450belt, 70deck, 380turrets, 230CT; 2x1-305/45, 2x1-274/45, 4x2-139/45, 4x1-65/50, 18x1-47/40, 8x5-37/20, 2-450TT
Charlemagne	3	20	Charlemagne	1897		11300t, 117.7x20.2x8.4m, 20b,3vte, 15000hp, 18kts, 694p; Harvey- 400belt, 90deck, 380turrets, 330CT; 2x2-305/40, 10x1-139/45, 8x1-100/45, 20x1-47/40, 4x1-37/20, 2-450TT
		21	Gaulois	1899		
		22	Saint-Louis	1900		
Masséna	1	23	Masséna	1898		11735t, 115.5x20.3x8.8m, 24b,3vte, 14200hp, 17kts, 667p; nickel steel- 450belt, 110decks, 400turrets, 350CT; 2x1-305/40, 2x1-274/45, 8x1-139/45, 8x1-100/45, 12x1-47/40, (3x5+5x1)-37/20, 2-450TT
Bouvet	1	24	Bouvet	1898		12007t, 122.6x21.4x8.4m, 32b,3vte, 15000hp, 18kts, 666p; Harvey- 400belt, 70decks, 380turrets, 300CT; 2x1-305/40, 2x1-274/45, 8x1-139/45, 8x1-100/45, 12x1-47/40, (2x5+5x1)-37/20, 2-450TT

						11860t, 122.4x20.8x8.4m, 20b,3vte, 16500hp, 18kts, 682p; Harvey- 330belt, 65deck, 290turrets, 300CT; 2x2-305/40, 8x1-165/45, 8x1-100/45, 20x1-47/40, 4x1-37/20, 2-450TT
						8948t, 108.0x22.2x7.0m, 12b,3vte, 11000hp, 17kts, 464p; Harvey- 280belt, 80deck, 300turrets, 240CT; 2x1-274/40, 7x1-139/45, 12x1-47/40, 2x1-37/20, 2-450TT
						12892t, 125.9x21.4x8.4m, 24b,3vte, 16700hp, 17kts, 714p; Harvey- 300belt, 110deck, 325turrets, 300CT; 2x2-305/40, 10x1-165/45, 8x1-100/45, 22x1-47/40, 2x1-37/20, 2-450TT
	Tonnerre	1	Tonnerre	1879		5765(1)-5871(2)t, 76.0x17.6x6.5-7.2m, 8b,1hc, 4200-4500hp, 13.7kts, 220p; iron- 330belt, 50deck, 330turret; 1x2-274/20, 4x1-47/40, 4x5-37/20(1), 6x5-37/20(2)
		2	Fulminant	1882		
	Tempête	3	Tempête	1879		4793(3)-4635(4)t, 76.0x17.6x5.8m, 4b,1hc(3)-4b,2hc(4), 2000hp, 11.7(3)-10.7(4)kts, 174p; iron- 330belt, 50deck, 350turret; 1x2-340/18(4), 1x2-274/20(3), 2x1-47/40(4), 4x5-37/20(3), 6x5-37/20(4), 2-350TT(4)
		4	Vengeur	1882		
BC	Furieux	1	Furieux	1887		5683t, 75.9x17.8x6.9m, 8b,2vte, 5145hp, 14.3kts, 235p; steel- 450belt, 90deck, 450barbettes; 2x1-240/40, 6x1-47/40, 10x5-37/20, 2-350TT
		2	Jemmapes	1894		6476t, 89.7x17.5x7.1m, 16b,2hte, 9000hp, 16.7kts, 313p; NS- 450belt, 100deck, 450turrets, 100CT; 2x1-340/42, 4x1-100/45, 4x1-47/40, 10x5-37/20, 2-450TT
7	Valmy	1894				

Amiral Tréhouart	2	8	Amiral Tréhouart	1896		6681t, 89.7x17.8x7.1m, 16b,2vte, 8500hp, 16.5-17kts, 343-362p; NS- 450belt, 110deck, 450turrets, 100CT; 2x1-305/45, 8x1-100/45, 4x1-47/40, 10x5-37/20(8), (8x5+4x1)-37/20(9), 2-450TT
		9	Bouvines	1894		

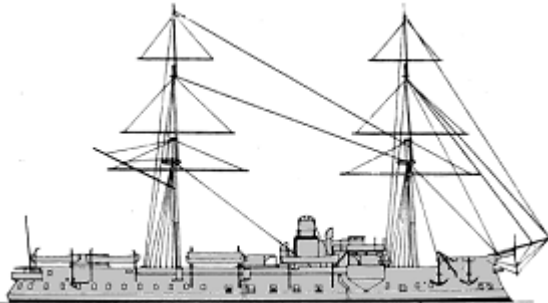
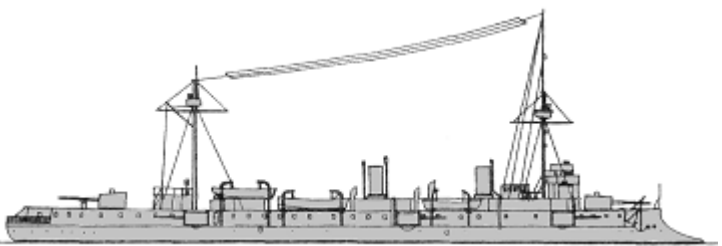
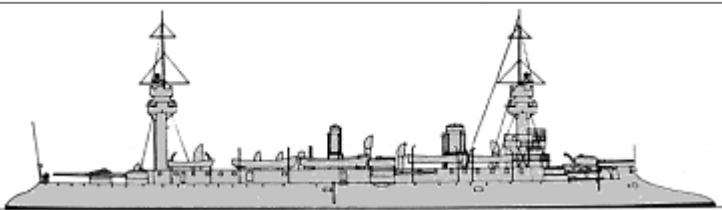
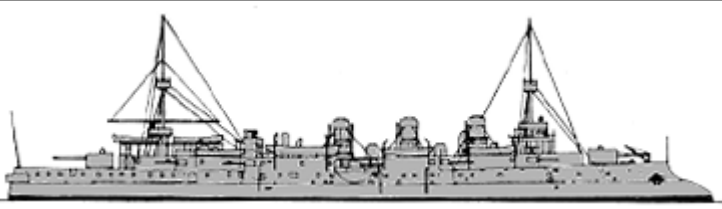
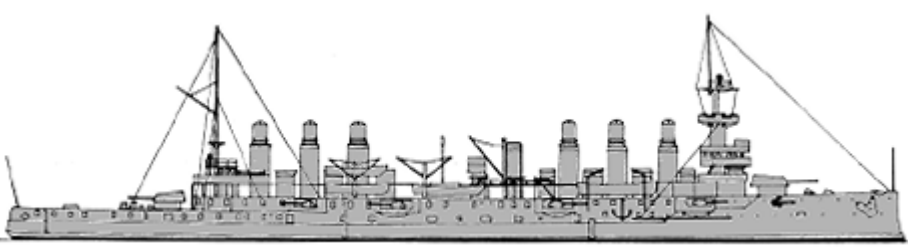

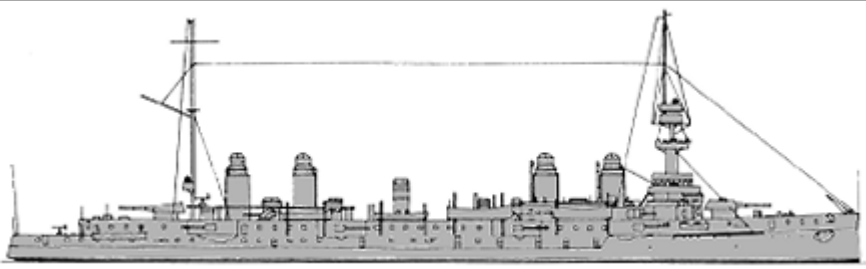
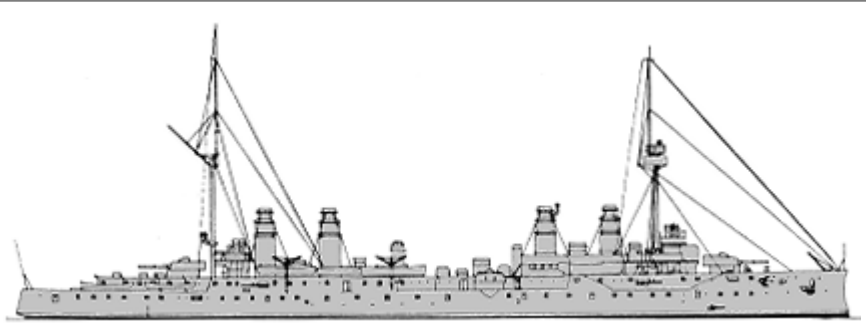
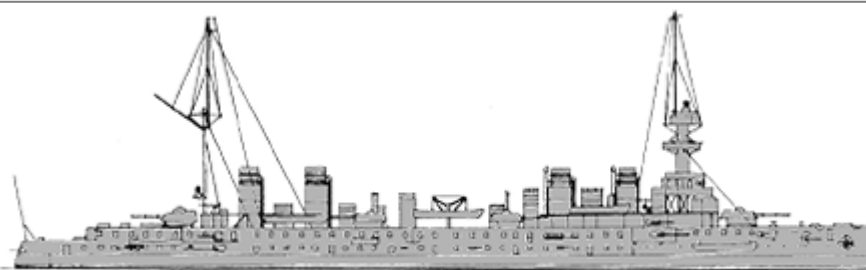
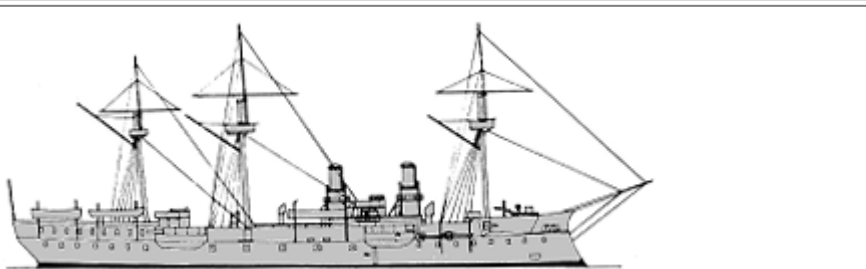
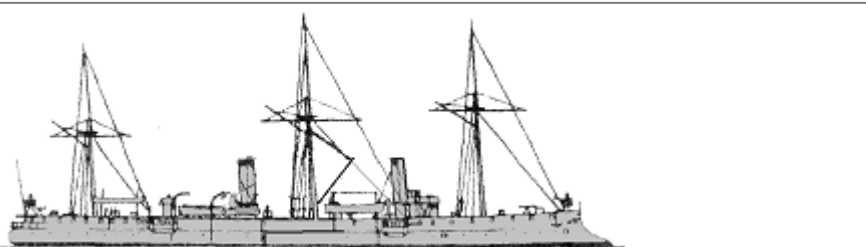
CRUISERS

CA	Vauban	1	1	Vauban	1885		6112t, 81.0x17.5x7.7m, 8b,2vc, 4400hp, 14.5kts, 440p; iron- 250belt, 50deck, 200barbettes; 4x1-240/18, 1x1-194/20, 6x1-139/21, 4x1-47/40, 12x5-37/20, 2-350TT
	Amiral Charner	4	2	Amiral Charner	1894		4681-4736t, 110.0x14.0x6.0m, 16b,3hte(2,4,5)-16b,3vte(3), 8000(2,4,5)-8700(3)hp, 18.2(2,4,5)-19(3)kts, 393p; steel- 90belt, 40deck, 110turrets, 110CT; 2x1-194/45, 6x1-139/45, 4x1-65/50, 4x1-47/40, 6x5-37/20, 4-450TT
			3	Bruix	1896		
			4	Chanzy	1894		
			5	Latouche-Tréville	1895		
	Dupuy de Lôme	1	6	Dupuy de Lôme	1895		6676t, 114.0x15.7x7.5m, 13b,2hte+1vte, 13000hp, 19.7kts, 526p; steel- 100belt, 20deck, 200turrets, 130CT; 2x1-194/45, 6x1-165/45, 4x1-65/50, 8x1-47/40, 8x5-37/20, 2-450TT
Pothuau	1	7	Pothuau	1897		5374t, 113.0x15.3x6.5m, 18b,2vte, 10000hp, 19kts, 459p; NS- 60belt, 35deck, 170turrets, 230CT; 2x1-194/40, 10x1-139/45, 10x1-47/40, 8x1-37/20, 4-450TT	
Jeanne d'Arc	1	8	Jeanne d'Arc	1902		11270t, 145.4x19.4x8.1m, 48b,3vte, 33000hp, 21.8kts, 651p; Harvey- 150belt, 65deck, 160turrets, 150CT; 2x1-194/40, 14x1-139/45, 16x1-47/40, 6x1-37/20, 2-450TT	
		9	Montcalm	1902		9177(9)-9548(10)t, 138.0x19.4x7.7m, 20b,3vte(9)-28b,3vte(10), 19600hp,	

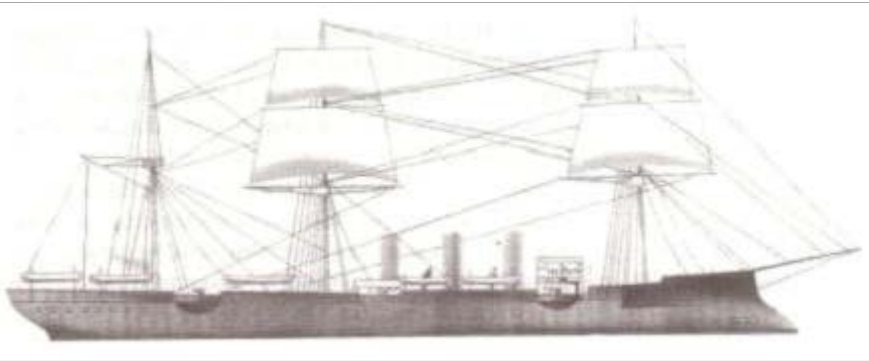
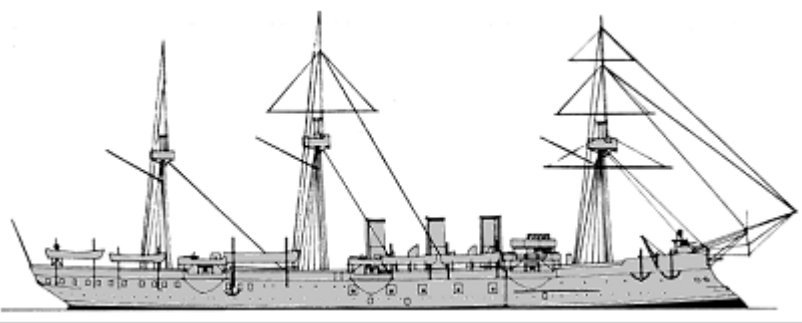
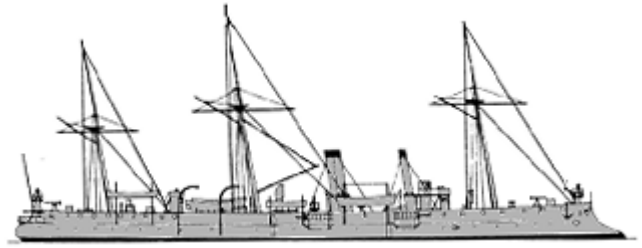
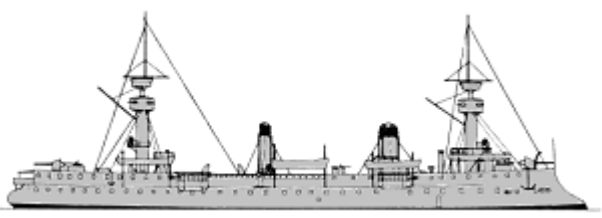
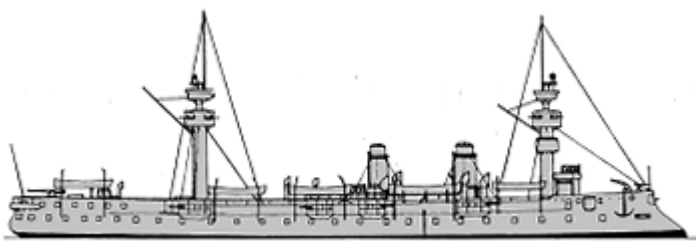
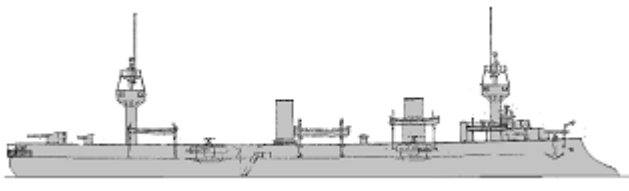
Gueydon	2	10	Gueydon	1903		21kts, 566p; Harvey- 150belt, 55deck, 200turrets, 160CT; 2x1-194/40, 8x1-165/45, 4x1-100/45, 16x1-47/40, 4x1-37/20, 2-450TT
Duplex	3	11	Duplex	1903		7432(11)-7547(12)-7602(13)t, 130.0x17.8x7.4m, 24b,3vte(11,12)-20b,3vte(13), 17500hp, 21kts, 531p; Harvey- 100belt, 70deck, 160turrets, 80CT; 4x2-165/45, 4x1-100/45, 10x1-47/40, 4x1-37/20, 2-450TT
		12	Desaix	1904		
		13	Kléber	1904		
Gloire	5	14	Amiral Aube	1904		9534(14)-10233(15)-10212(16)-9458(17)-9856(18)t, 139.8x20.2x7.5-7.7m, 24b,3vte(14,17,18)-28b,3vte(15,16), 21800hp, 21.5kts, 615p; Harvey- 150belt, 80deck, 170turrets, 150CT; 2x1-194/40, 8x1-165/45, 6x1-100/45, 18x1-47/40, 2-450TT
		15	Condé	1904		
		16	Gloire	1904		
		17	Marseillaise	1903		
		18	Sully	1904		
Sfax	1	1	Sfax	1887		4561t, 91.6x15.0x7.7m, 12b,2hc, 6500hp, 16.7kts, 486p; steel- 60deck, 25CT; 6x1-165/28, 10x1-139/30, 6x1-47/40, (4x5+6x1)-37/20, 2-350TT
Forbin	3	2	Forbin	1889		1935(2)-2012(3)-1901(4)t, 95.0x9.0x5.2m, 6b,2hc, 5800hp, 20-20.5kts, 199p; steel- 40deck, 20CT(3); 4x1-139/30, 8x1-47/40(2,3), 3x1-47/40(4), 4x5-37/20, 4-350TT(4), 150mines
		3	Surcouf	1890		
		4	Coëtlogon	1894		
Tage	1	5	Tage	1890		7469t, 118.9x16.3x7.7m, 12b,2hte, 12500hp, 19.2kts, 538p; steel- 55slopes, 50deck, 90CT; 8x1-165/30, 8x1-139/30, 6x1-47/40, 16x1-37/20, 4-380TT

						
Amiral Cécille	1	6	Amiral Cécille	1890		5839t, 115.5x15.0x6.8m, 12b,4vc/2, 10200hp, 19.4kts, 517p; steel- 100slopes, 55deck, 90CT; 8x1-165/30, 10x1-139/30, 6x1-47/40, 14x5-37/20, 3-380TT
Troude	3	7	Cosmao	1891		1923(7)-1968(8)-1994(9)t, 95.0x9.0x5.2m, 5b,2hc, 5800hp, 20.5kts, 201p; steel- 40deck, 25CT(8,9); 4x1-139/30, 10x1-47/40, 4x1-37/20, 150mines
		8	Lalande	1890		
		9	Troude	1891		
Davout	1	10	Davout	1891		3031t, 88.0x12.0x6.6m, 10b,2ite, 9000hp, 20.7kts, 329p; steel- 100slopes, 50deck, 70CT; 6x1-165/30, 4x1-65/50, 4x1-47/40, 2x1-37/20, 2-350TT
Alger	3	11	Alger	1891		4313(11)-4406(12)-4044(13)t, 107.0x13.0x6.1-6.5m, 24b,2vte(11)-8b,2hte(12,13), 8000(11,12)-10000(13)hp, 19(11)-19.5(12)-20(13)kts, 387(11)-405(12,13)p; steel- 100slopes, 50deck, 50shields(12,13), 50(11)-75(12,13)CT; 4x1-165/28, 6x1-139/30, 2x1-65/50, 8x1-47/40(11), 12x1-47/40(12,13), 8x5-37/20(11), 10x5-37/20(12,13), 7-350TT
		12	Isly	1893		
		13	Jean Bart	1891		
Suchet	1	14	Suchet	1894		3362t, 97.0x12.0x6.1m, 24b,2hte, 9500hp, 20.4kts, 335p; steel- 100slopes, 80deck, 70CT; 6x1-165/30, 4x1-100/45, 8x1-47/40, 8x1-37/20, 7-350TT
		15	Linois	1895		2285(15)-2318(16,17)t, 98.0(15)-100.6(16,17)x10.6(15,17)-11.0(16)x5.4m, 6b,2vte(15)-16b,2vte(16,17), 6800hp, 20.5kts, 201p; steel- 40deck, 75shields,
		16	Galilée	1897		

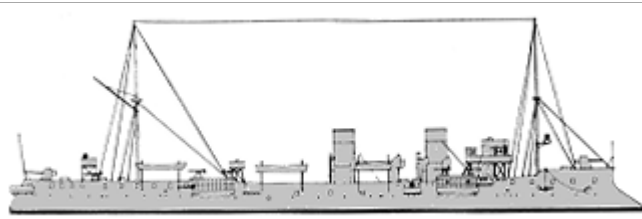
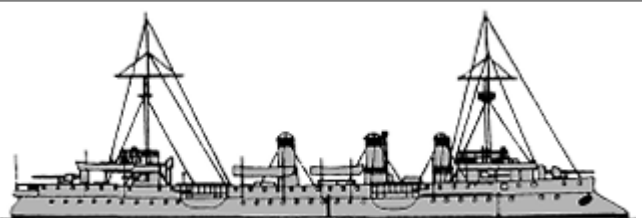
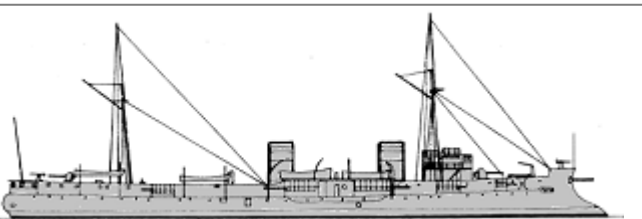
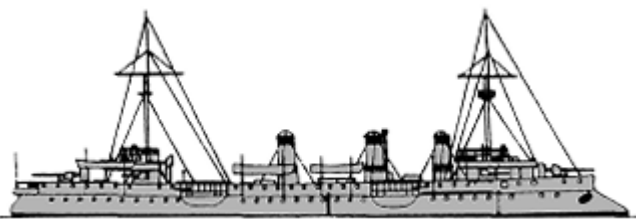
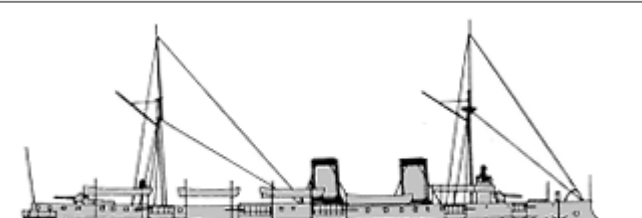
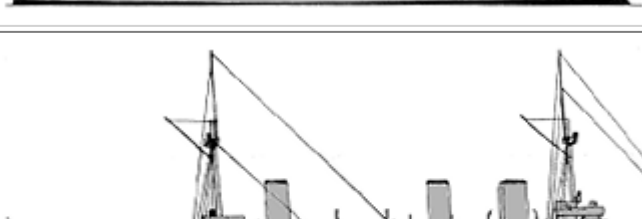

CL

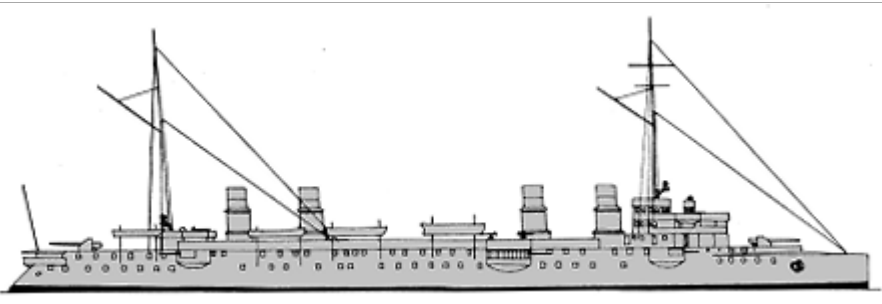
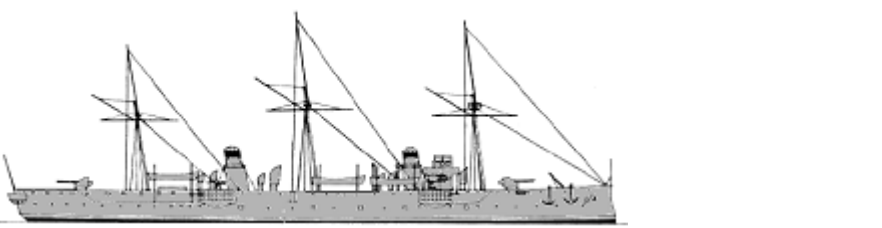
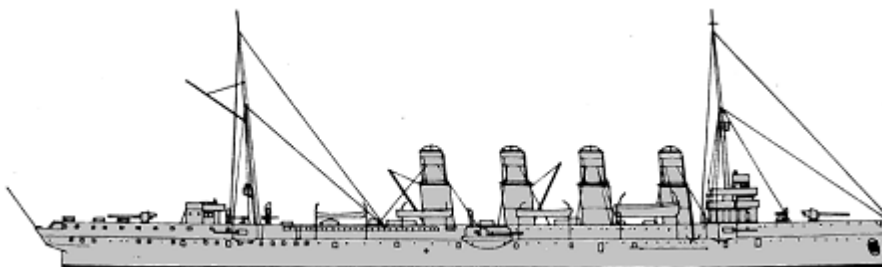
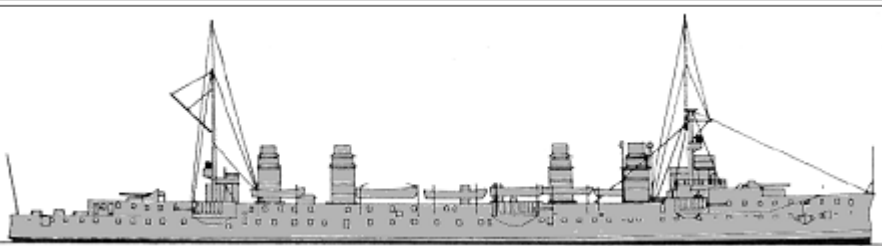
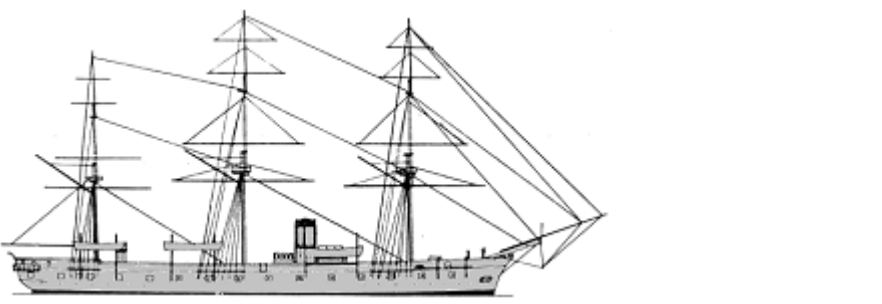
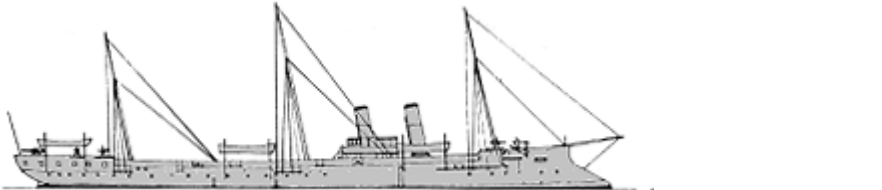

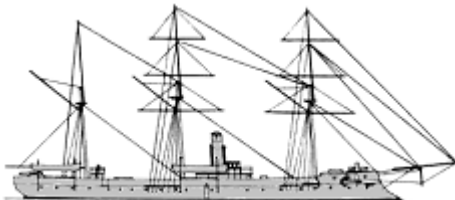
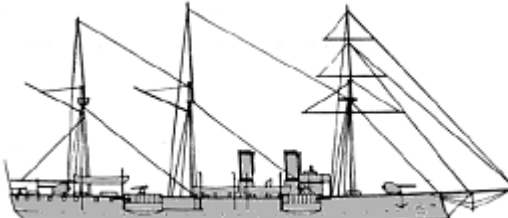

Linois	3					125CT; 4x1-139/45, 2x1-100/45, 10x1-47/40, 4-450TT(15), 2-450TT(16,17), 120mines(15,16)
		17	Lavoisier	1898		
Friant	3	18	Friant	1895		3982(18)-3824(19)-3809(20)t, 97.0x13.0x6.3m, 20b,2vte(18,19)-24b,2vte(20), 9500hp, 18.7kts, 339p; steel- 80slopes, 30deck, 50shields, 75CT; 6x1-165/45, 4x1-100/45, 4x1-47/40, 11x1-37/20, 2-350TT
		19	Chasseloup-Laubat	1895		
		20	Bugeaud	1896		
Descartes	2	21	Descartes	1896		3960t, 99.0x13.0x6.5m, 16b,2vte, 8500hp, 19.5kts, 383(21)-401(22)p; steel- 60slopes, 45deck, 50shields, 70CT; 4x1-165/45, 10x1-100/45, 8x1-47/40(21), 14x1-47/40(22), 4x1-37/20(21), 8x1-37/20(22), 2-450TT
		22	Pascal	1897		
D'Assas	3	23	Cassard	1898		3890(23,25)-3962(24)t, 99.0x13.7x6.3m, 20b,2vte, 10000hp, 20kts, 370-392p; 100slopes, 70deck, 50shields, 100CT; 6x1-165/45, 4x1-100/45, 10x1-47/40, 9x1-37/20(23,25), 5x1-37/20(24), 2-450TT
		24	D'Assas	1898		
		25	Du Chayla	1898		
Catinat	2	26	Catinat	1898		4048(26)-4001(27)t, 101.0x13.6x6.4m, 16b,2vte, 9500hp, 19.5(26)-20(27)kts, 400p; steel- 60slopes, 45deck, 50shields, 70CT; 4x1-165/45, 10x1-100/45, 10x1-47/40, 4x1-37/20, 2-350TT, 50mines
		27	Protet	1899		
D'Entrecasteaux	1	28	D'Entrecasteaux	1899		8142t, 120.0x17.8x7.5m, 5b,2vte, 14500hp, 19.2kts, 559p; Harvey- 100slopes, 55deck, 250turrets, 250CT; 2x1-240/40, 12x1-139/30, 12x1-47/40, 6x1-37/20, 6-450TT
Guichen	1	29	Guichen	1899		8151t, 139.0x17.0x7.5m, 36b,3vte, 25000hp, 23.5kts, 604p; Harvey- 100slopes, 55deck, 60casemates, 160CT; 2x1-165/45, 6x1-139/45, 10x1-47/40, 5x1-37/20, 2-450TT



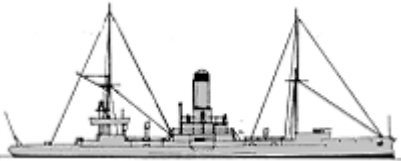
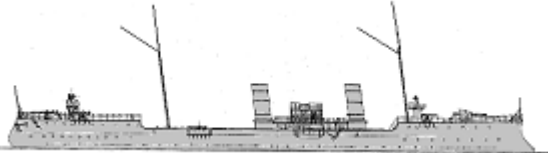



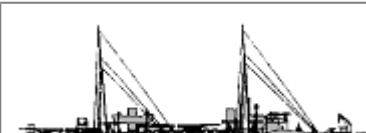
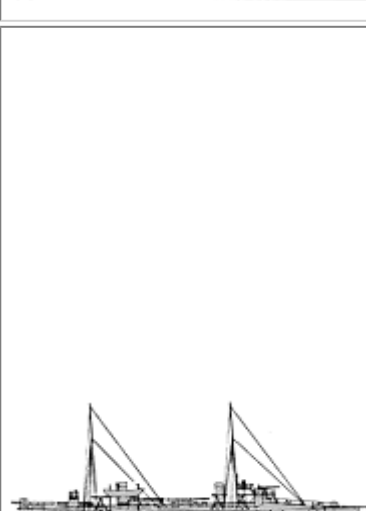





							
D'Estrées	30	D'Estrées	1899		2428t, 95.0x12.0x5.4m, 8b,2vte, 8500hp, 20.5kts, 235p; steel- 43deck; 2x1-139/45, 4x1-100/45, 8x1-47/40, 2x1-37/20		
	2	31	Infernet			1900	
Châteaurenault	1	32	Châteaurenault	1902		7898t, 135.0x17.0x7.4m, 14b,3vte, 23000hp, 24kts, 604p; Harvey- 100slopes, 55deck, 60casemates, 160CT; 2x1-165/45, 6x1-139/45, 10x1-47/40, 5x1-37/20	
Jurien de la Gravière	1	33	Jurien de la Gravière	1903		5595t, 137.0x15.0x6.3m, 24b,3vte, 17400hp, 22.9kts, 463p; 65slopes, 80deck, 70shields, 100CT; 8x1-165/45, 10x1-47/40, 6x1-37/20, 2-450TT	
CLL							
	Iphigénie	1	1	Iphigénie	1883		3346t, 73.2x14.2x6.8m, 6b,1hc, 2780hp, 14kts, 435p; 2x1-165/21, 18x1-139/21, 2x1-100/27, 8x5-37/20, 1-350TT
	Milan	1	2	Milan	1885		1705t, 92.1x10.0x4.8m, 12b,2hc, 4000hp, 18.4kts, 194p; 2x1-100/26, 12x1-47/40, 2-350TT
Inconstant	1	3	Fulton	1888		898t, 61.3x8.0x4.2m, 6b,1hc, 1100hp, 13.8kts, 116p; 3x1-139/30, 1x1-100/26, 5x5-37/20	









						
Kersaint	1	4	Kersaint	1898		1276t, 68.6x10.5x4.6m, 4b,1vte, 2400hp, 16kts, 146p; 1x1-139/45, 5x1-100/45, 7x1-37/20

TORPEDO SHIPS







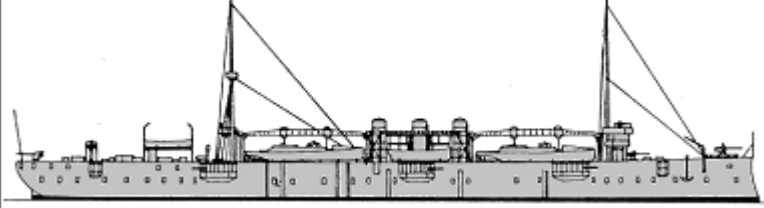

PGT	Condor	4	1	Condor	1886		1229(1)-1268(2)-1311(3)-1266(4)t, 68.0ppx9.0x4.7m, 4b,2ic(1-3)-4b,2hc(4), 3000hp, 17.5(1)-17(2-4)kts, 137p; steel- 40deck; 5x1-100/26, 4x1-47/40, 6x5-37/20
			2	Épervier	1887		
			3	Faucon	1887		
			4	Vautour	1889		
	Wattignies	2	5	Wattignies	1892		1280t, 68.0ppx8.9x4.8m, 4b,2hte(5)-8b,2hte(6), 4000hp, 18.5(5)-18(6)kts, 162(5)-173(6)p; steel- 40deck; 5x1-100/26, 6x1-47/40, 4x1-37/20
			6	Fleurus	1898		
	Bombe	8	7	Bombe	1887		369-430t, 59.2ppx6.0x3.2m, 4b,2vc, 1800hp, 18-19kts, 70p; steel- 13CT; 2x1-47/40, 5x1-37/20, 2x1-350TT
			8	Couleuvrine	1887		
			9	Dague	1888		
			10	Dragonne	1888		
			11	Flèche	1888		
			12	Lance	1890		
			13	Sainte-Barbe	1890		
			14	Salve	1890		
	Lévrier	2	15	Léger	1891		503t, 63.0x7.0x3.2m, 6b,2vte, 2400hp, 89p; 1x1-65/50, 3x1-47/40, 2x1-37/20, 2x1-450TT
			16	Lévrier	1891		
	D'Iberville	3	17	D'Iberville	1894		952(17)-970(18,19)t, 81.9x8.1(17)-8.2(18,19)x3.5m, 8b,2vqe(17,18)-8b,2vte(19), 5000hp, 21.5-22kts, 143(17)-140(18,19)p; steel- 20belt(18,19), 40slopes(17), 20deck(18,19), 40CT(17); 1x1-100/45, 3x1-65/50, 6x1-47/40(17), 7x1-47/40(18,19), 2x1-450TT(18,19)
			18	Cassini	1895		
			19	Casabianca	1896		

	Dunois	2	20	Dunois	1898		889t, 78.0x8.4x3.9m, 8b,2vte, 7500hp, 21.7-22kts, 137p; steel- 25belt, 10deck, 50CT; 6x1-65/50, 6x1-47/40					
			21	La Hire	1899							
DD	Durandal	3	1	Durandal	1899		296(1,2)-306(3)t, 57.6x6.3x3.2m, 2b,2vte, 4800hp, 26kts, 52p; 1x1-65/50, 6x1-47/40, 2x1-380TT					
			2	Hallebarde	1899							
			3	Fauconneau	1900							
	Framée	3	4	Yatagan	1900		314t, 58.1x6.3x3.0m, 4b,2vte, 4800-5200hp, 26kts, 48p; 1x1-65/50, 6x1-47/40, 2x1-380TT					
			5	Pique	1901							
			6	Epée	1901							
	Pertuisane	4	7	Pertuisane	1902		344t, 57.6x6.3x3.2m, 2b,2vte, 4800hp, 26kts, 52p; 1x1-65/50, 6x1-47/40, 2x1-380TT					
			8	Escopette	1903							
			9	Flamberge	1903							
			10	Rapière	1903							
	Arquebuse	20	11	Carabine	1903		298t, 58.2x6.4x3.2m, 2b,2vte, 6300hp, 28kts, 60p; 1x1-65/50, 6x1-47/40, 2x1-380TT					
			12	Sarbacane	1903							
			13	Arquebuse	1903							
			14	Arbalète	1903							
			15	Mousquet	1903							
			16	Javeline	1903							
			17	Sagaie	1903							
			18	Epieu	1903							
			19	Harpon	1903							
			20	Fronde	1903							
			21	Francisque	1904							
			22	Sabre	1904							
			23	Dard	1904							
	Balny	6	1-6	Balny, Déroulède, Doudart de la Grée, Capitaine Cuny, Capitaine Mehl, Challier	1886		65t, 40.7x3.3x1.2m, 1b,1cr, 580hp, 19kts, 22p; 2x5-37/20, 2-350TT					
				Coureur	3			7	Coureur	1888		125(7)-131(8,9)t, 44.9(7)-45.1(8,9)x4.3(7)-4.4(8,9)x1.4m, 2b,2vcr(7)-2b,2vte(8,9), 1500(7)-1750(8,9)hp, 23.5kts; 2x1-47/40, 2-350TT
								8	Véloce	1892		
								9	Grondeur	1892		





TB	Ouragan	4	10	Alarme	1889		177t, 46.7x4.8x1.8m, 2b,1vqe, 1400hp, 16kts, 29-32p; 2x1-47/40, 4x1-350TT
			11	Téméraire	1889		
			12	Aventurier	1889		
			13	Défi	1889		
	Agile	6	14	Agile	1889		119(14-17)-129(18,19)t, 43.6(14-17)-44.2(18,19)x4.6x1.1m, 1b,1vte(14)-2b,1vte(15-19), 1100hp, 27kts; 3x5-37/20, 3x1-350TT(14-16), (1+1x1)-380TT(17-19)
			15	Eclaire	1891		
			16	Kabyle	1892		
			17	Orage	1892		
			18	Sarrazin	1894		
			19	Tourbillon	1894		
	Avant-Garde	6	20	Archer	1893		128(20)-127(21,22)-129(23-25)t, 42.0pp(20)-41.9pp(21-25)x4.5x1.3m, 2b,2cr(20)-2b,2vte(21-25), 1250(20)-1750(21-25)hp, 20.5(20)-21(21-25)kts, 27p; 2x1-47/40, (1+1x1)-350TT
			21	Turco	1892		
			22	Zouave	1892		
23			Dragon	1892			
24			Grenadier	1892			
25			Lancier	1893			
Corsaire	1	26	Corsaire	1893		168t, 50.5x4.5x1.7m, 2b,2vte, 2500hp, 25.5kts; 2x5-37/20, 2x1-380TT	
Mousquetaire	1	27	Mousquetaire	1893		123t, 48.0x4.7x1.3m, 2b,2vte, 2100hp, 24.5kts; 2x5-37/20, 2x1-450TT	
Chevalier	1	28	Chevalier	1894		135t, 43.8x4.5x1.5m, 2b,2vte, 2200hp, 24.5kts; 2x5-37/20, 2x1-450TT	
Argonaute	2	29	Argonaute	1894		129t, 42.9x4.5x1.7m, 2b,2vte, 2000hp, 23.5kts, 27p; 2x1-47/40, (1+1x1)-380TT	
		30	Tourmente	1894			
Averne	2	31	Averne	1894		131t, 43.9x4.6x1.3m, 2b,2vte, 1750hp, 23.5kts; 2x1-47/40, (1+1x1)-380TT	
		32	Dauphin	1894			
Filibustier	2	33	Ariel	1895		123t, 42.0x4.5x1.7m, 2b,2vte, 2000hp, 23.5kts; 2x1-47/40, (1+1x1)-380TT	
		34	Aquilon	1896			
Forban	1	35	Forban	1896		150t, 44.0x4.6x1.4m, 2b,2vte, 3260hp, 29kts, 29p; 2x1-37/20, 2x1-350TT	
Mangini	1	36	Mangini	1897		140t, 45.0ppx4.7x1.5m, 2b,2vte, 2100hp, 24kts, 27p; 2x1-47/40, (1+1x1)-380TT	
Cyclone	5	37	Cyclone	1899		150(37)-165(38-41)t, 46.4(37)-46.6(38-41)x4.7(37)-4.8(38-41)x1.5m, 2b,2vte, 4200(37)-3800(38-41)hp, 29kts; 2x1-47/40, 1x2-380TT	
		38	Bourrasque	1902			
		39	Rafale	1902			
		40	Borée	1901			
		41	Tramontane	1902			

	Takou	1	42	Takou	1898		284t, 59.0x6.4x2.6m, 4b,2vte, 5000hp, 27kts, 57p; 4x1-47/40, 2x1-37/20, 2x1-380TT
	Mistral	6	43	Mistral	1901		183t, 45.0x5.2x1.6m, 2b,2vte, 4200hp, 26kts, 30p; 24belt, 9deck; 2x1-47/40, 2x1-380TT
			44	Siroco	1901		
			45	Simoun	1901		
			46	Typhon	1903		
			47	Trombe	1902		
			48	Audacieux	1900		
TB2cl	No24	3	1-3	No43, 44, 50	1879-1880	No picture	32-35t, 26.0x3.6x0.8m, 1b,1vcr, 320-500hp, 18kts; 2-350TT
	No28	1	4	No28	1879	No picture	43t, 34.5x3.7x0.8m, 1b,1vcr, 500hp, 18kts, 11p; 1x2-380TT
	No29	1	5	No56	1882	No picture	11t, 18.3x2.3x0.6m, 1b,1cr, 12kts, 12p; 1-350TT
	No75	51	6-56	No75-125	1887-1889	No picture	53t, 35.0ppx3.4x0.9m, 1b,1vcr, 525hp, 20kts, 16p; 2x5-37/20, 2-380TT
	No126	4	57-60	No126-129	1889-1890	No picture	78t, 36.0x3.9x1.2m, 1b,1vcr, 900hp, 21kts, 21p; 2x5-37/20, 2x1-380TT
	No130	14	61-74	No130-132, 134-144	1890-1892		52t, 34.0ppx3.5x0.9m, 1b,1vte, 720hp, 20kts, 18p; 2x1-37/20, 2x1-380TT
	No145	25	75-99	No145-149, 152-171	1891-1893		78t, 35.9ppx3.9x1.2m, 1b,1vte(75-88,98,99)-2b,1vte(89-97), 1000hp, 21kts, 22-23p; 2x5-37/20, (1+1x1)-380TT
	No172	29	100-128	No172-200	1892-1895		78t, 35.9pp(100-119)-36.9pp(120-128)x3.9x1.2m, 2b,1vte(100-109,116-119)-1b,1vte(110-115,120-128), 1350hp, 22(100-122)-23(123-128)kts, 22-23p; 2x5-37/20, (1+1x1)-380TT
	A	8	129-136	A, B, D, E, F, G, H, I	1894-1898	No picture	14t, 18.5x3.0x1.4m, 1b,1cr, 250hp, 17kts; 1-350TT
	C	1	137	C	1894	No picture	14t, 19.0x2.9x1.5m, 1b,1vc, 20.5kts; 1-350TT
	No201	92	138-229	No201-241, 6S, 243, 7S, 10S-14S, 250-253, 15S, 16S, 256-260, 1M, 2M, 263-270, 3M, 4M, 273-276, 8S, 278-283, 17S-19S, 5M, 288, 289, 6M, 20S, 21S, 9S	1897-1904		83-90t, 37.0x4.2x1.2m, 2b,1vte(138-179,181-229)-2b,1st(180), 1500-1800(138-179,181-229)-1900(180)hp, 24(138-214)-26(215-229)kts, 23p; 2x5-37/20, (1+1x1)-380TT
	No293	1	230	No293	1904		94t, 39.5x4.1x1.3m, 2b,3st, 2000hp, 26kts; 2x5-37/20, (1+1x1)-380TT
No294	1	231	No294	1904		100t, 38.5x4.0x1.4m, 2b,2st, 1800hp, 24kts; 2x5-37/20, (1+1x1)-380TT	
CTB	Foudre	1	1	Foudre	1897		6089t, 118.7x17.2x7.1m, 24b,2vte, 11500hp, 19kts, 410p Harvey- 120slopes, 60deck, 55shields, 120CT; 8x1-100/45, 4x1-65/50, 4x1-37/20, 10TBs

SUBMARINES

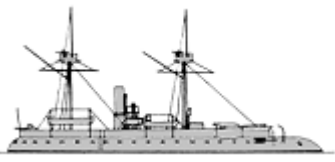
SS	Gymnôte	1	1	Gymnôte	1888		32/33t, 18.4x1.8x1.7m, 1em, 90hp, 7.3/4.3kts, 5p, 20m; 2-350TC
	Gustave Zédé	1	2	Gustave Zédé	1898		266/272t, 48.5x3.2x3.2m, 1em, 208hp, 19p, 30m; 1-450TT
	Morse	1	3	Morse	1900		143/149t, 36.5x2.7x2.8m, 1em, 284hp, 7.3/5.5kts, 13p, 30m; 1-450TT
	Narval	1	4	Narval	1900		117/202t, 34.0x3.8x1.8m, 1b, 1vte/em, 220/80hp, 9.9/5.3kts, 13p, 30m; 4-450TC
	Sirène	4	5	Sirène	1901		157/213t, 32.5x3.9x2.5m, 1b, 1vte/em, 250/100hp, 9.8/5.8kts, 13p, 30m; 4-450TC
			6	Triton	1901		
			7	Espadon	1902		
			8	Silure	1902		
	Farfadet	4	9	Farfadet	1902		185/202t, 41.3x2.9x2.6m, 1em, 183hp, 6.1/4.3kts, 16p, 30m; 4-450TC
			10	Korrigan	1902		
			11	Gnôme	1903		
			12	Lutin	1903		
	Français	2	13	Français	1902		147/160t, 36.7x2.7x2.8m, 1em, 307hp, 10.1/8.3kts, 13p, 30m; 1-450TT, 2-450TC
			14	Algerien	1902		
	Naiade	15	15-29	Naiade, Protée, Perle, Esturgeon, Bonite, Thon, Souffleur, Dorade, Lynx, Ludion, Loutre, Castor, Phoque, Otarie, Méduse	1904		71/74t, 23.7x2.2x2.6m, 1pe/em, 57/95hp, 7.2/6kts, 12p, 30m; 2-450TC

OTHER FIGHTING SHIPS

PG	Fusée	4	1	Flamme	1887		1073-1124t, 50.3x9.9x3.2m, 3b, 2vc, 1500hp, 12.5kts, 89p; compound(1,4)-steel(2,3)- 240belt, 50deck, 200barbette; 1x1-240/29, 1x1-90/28, 4x5-37/20
			2	Fusée	1885		
			3	Grenade	1889		
			4	Mitraille	1888		
	Achéron	4	5	Achéron	1888		1690(5,6)-1767(7,8)t, 55.2(5,6)-58.7(7,8)x12.3x3.6m, 4b, 2hc, 1600hp, 11.6-13kts, 110p; compound- 200belt, 50deck, 200turret; 1x1-274/29, 1x1-139/28(7,8), 2x1-100/26(5), 3x1-100/26(6), 2x1-47/40, 4x5-37/20(5,6), 7x5-37/20(7,8)
			6	Coccyte	1890		
			7	Phlégéon	1892		
			8	Styx	1892		
	Crocodile	3	9	Aspic	1880		465-492t, 44.1x7.3x2.9-3.3m, 2b, 1hc, 440hp, 10-11kts, 76p; 2x1-139/21, 2x1-90/36, (2-4)x5-37/20
			10	Capricorne	1882		
			11	Vipère	1881		
	Comète	1	12	Comète	1884		492t, 46.2ppx7.5x3.2m, 2b, 1hc, 500hp, 11-12kts, 76p; 2x1-139/21, 2x1-100/27, 3x5-37/20
Gabriel	1	13	Gabriel	1886	No picture	73t, 41.9x3.8x2.0m, 1b, 1vc, 580hp, 19kts, 23p; 1x1-139/30	

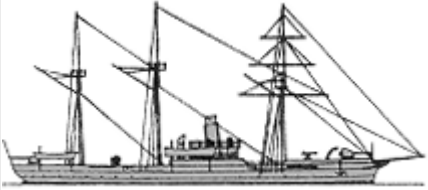
	Charmes		Charmes				
	Surprise	3	14	Surprise	1896		617-637t, 56.0-56.3ppx7.9-8.0x3.7m, 2b,1hte, 900hp, 13kts, 99p; 2x1-100/45, 4x1-65/50, 4x1-37/20
			15	Décidée	1898		
			16	Zélée	1900		
PR	Javelot	1	1	Javelot	1866	No picture	89t, 24.8x4.9x1.4m, 2, 45hp, 26p; 1x1-139/17, 1x1-47/40
	Berthe-de-Villers	2	2	Berthe-de-Villers	1884	No picture	200t, 37.4x7.4x0.9m, w, 36hp, 51p; 2x1-90/28, 4x5-37/20
			3	Jacquin	1884		
	Estoc	1	4	Estoc	1884	No picture	112t, 30.0x5.8x1.1m, 2, 45hp, 49p; 2x1-90/28, 3x5-37/20
	Niger	2	5, 6	Niger, Mage	1884-1888	No picture	25t; 2x1-37/20
	Doucet	2	7	Doucet	1885	No picture	120t, 29.6x11.0x0.8m, w, 48p; 1x1-47/40, 4x5-37/20
			8	Rollandes	1885		
	Opale	2	9, 10	Opale, Onyx	1892-1893	No picture	60t, 34p; 2x1-37/20
Vigilante	3	11	Argus	1900	No picture	123t, 44.2x7.3x0.6m, 2b,2vte, 500hp, 13kts, 53p; 2x1-90/24, 4x1-37/20	
		12	Vigilante	1900			
		13	Lieutenant Contal	1901			

[home](#)[World navies yesterday](#)[1905](#)

Germany 01 January 1905

BATTLESHIPS

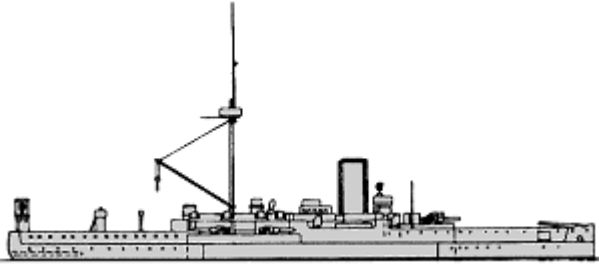
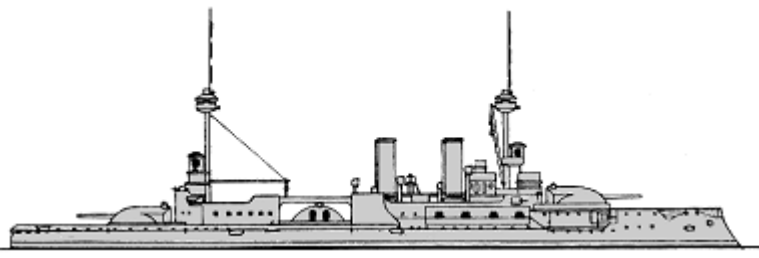
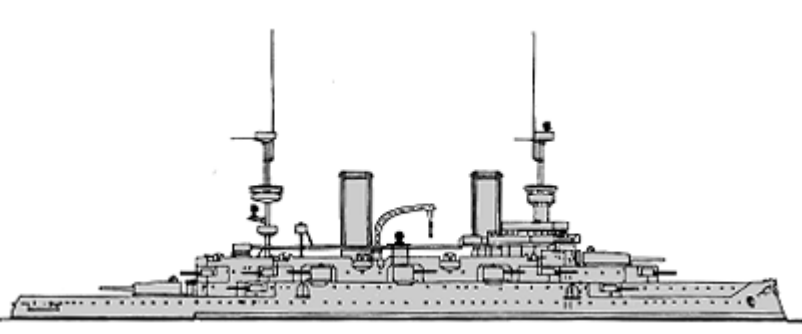
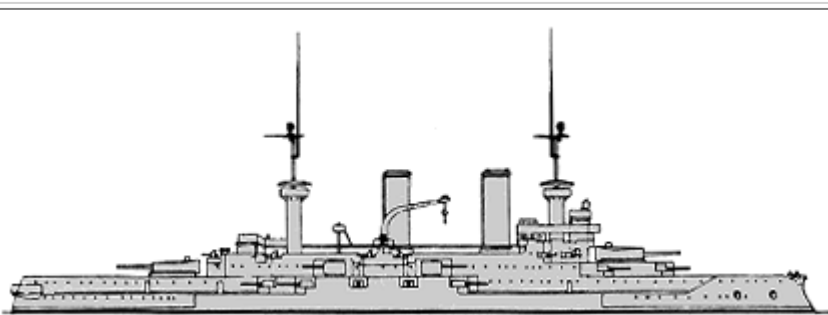
Sachsen	4	1	Sachsen	1878		7742-7938t, 98.2x18.4x6.5m, 8b,2hc, 6201-6454hp, 14.2-15.7kts, 317p; 254belt, 75deck, 254barbettes/citadel, 200CT; 6x1-263/20, 8x1-88/27, 6x1-87/22, 8x5-37/20, 2-450TT, 3-350TT
		2	Bayern	1881		
		3	Württemberg	1881		
		4	Baden	1883		
Kurfürst Friedrich Wilhelm	4	5	Kurfürst Friedrich Wilhelm	1894		10670t, 115.7x19.5x7.9m, 12b,2vte, 10000hp, 16.5kts, 568p; compound(5,7); 400belt, 60deck, 300barbettes, 300CT; 2x2-283/37, 1x2-283/32, 6x1-105/32(5), 8x1-105/32(6-8), 8x1-99/27, 6-450TT(5), 3-450TT(6-8)
		6	Brandenburg	1893		
		7	Weissenburg	1894		
		8	Wörth	1893		
Kaiser Friedrich III	5	9	Kaiser Friedrich III	1898		11785t, 125.3x20.4x8.3m, 12b,3vte(9,10)-10b,3vte(11-13), 13000hp, 17.5kts, 651p; 300belt, 65deck, 250turrets, 250CT; 2x2-238/37, 18x1-150/37, 12x1-88/27, 6-450TT
		10	Kaiser Wilhelm II	1900		
		11	Kaiser Wilhelm der Grosse	1901		
		12	Kaiser Karl der Grosse	1902		
		13	Kaiser Barbarossa	1901		
Wittelsbach	5	14	Wittelsbach	1902		12798t, 126.8x20.8x8.0m, 12b,3vte, 14000hp, 17.5kts, 683p; 225belt, 50deck, 250turrets, 250CT; 2x2-238/37, 18x1-149/37, 12x1-88/27, 6-450TT
		15	Wettin	1902		
		16	Zähringen	1902		
		17	Schwaben	1904		
		18	Mecklenburg	1903		

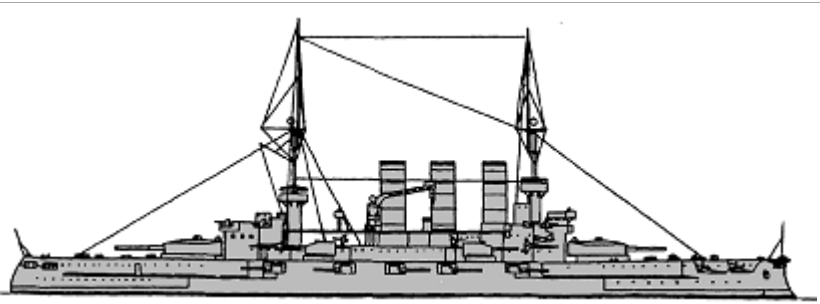
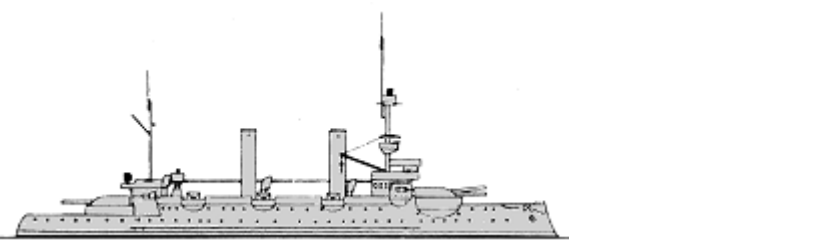
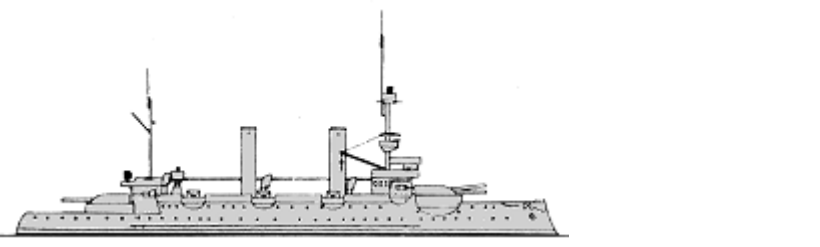
	Braunschweig	2	19 Braunschweig	1904		14394t, 127.7x25.6x8.1m, 14b,3vte, 17000hp, 18.2kts, 743p; 225belt, 40deck, 250turrets, 300CT; 2x2-283/37, 14x1-173/37, 18x1-88/32, 6-450TT
			20 Elsass	1904		
BC	Siegfried	6	1 Siegfried	1890		4236-4436t, 86.1x14.9x5.7m, 8b,2vte, 4700-5300hp, 15kts, 307p; compound; 240belt, 30(1-3,5)-50(4,6)deck, 200barbettes, 80(1-3,5)-160(4,6)CT; 3x1-238/32, 10x1-88/27, 3-450TT, 1-350TT
			2 Beowulf	1892		
			3 Frithjof	1893		
			4 Heimdall	1894		
			5 Hildebrand	1893		
			6 Hagen	1894		
	Odin	2	7 Odin	1896		4236-4436t, 86.2x15.4x5.6m, 8b,2vte, 5000(7)-5600(8)hp, 15.5kts, 307p; 220belt, 70deck, 200barbettes, 120CT; 3x1-238/32, 10x1-88/27, 4-450TT
8 Ägir	1896					

CRUISERS

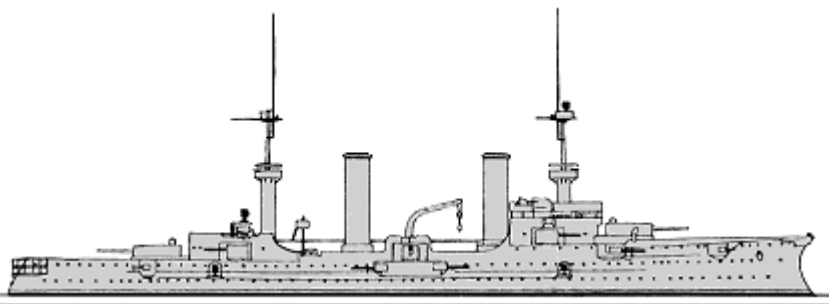
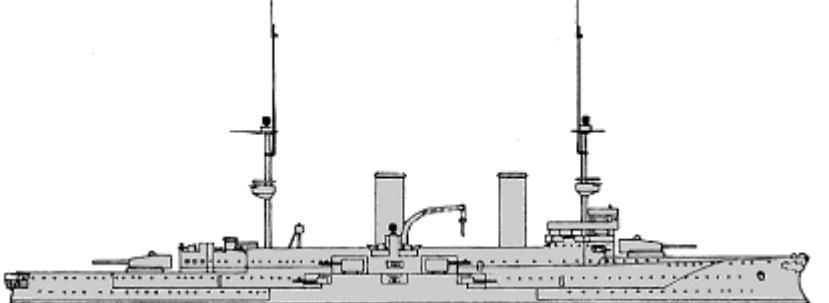

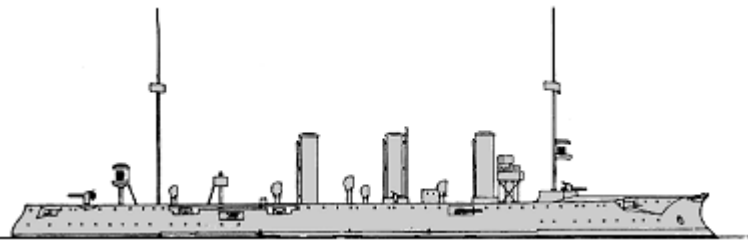
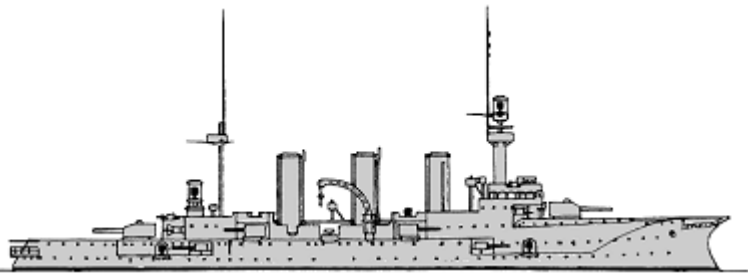
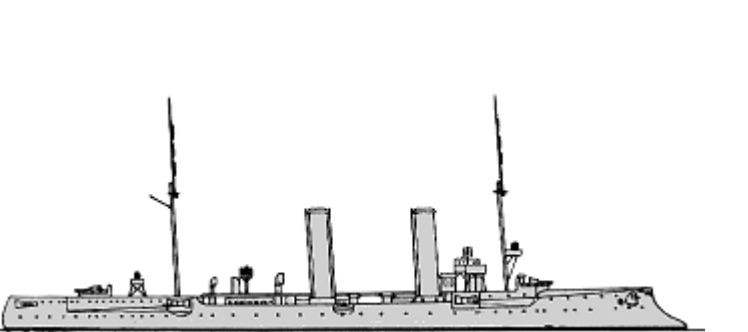
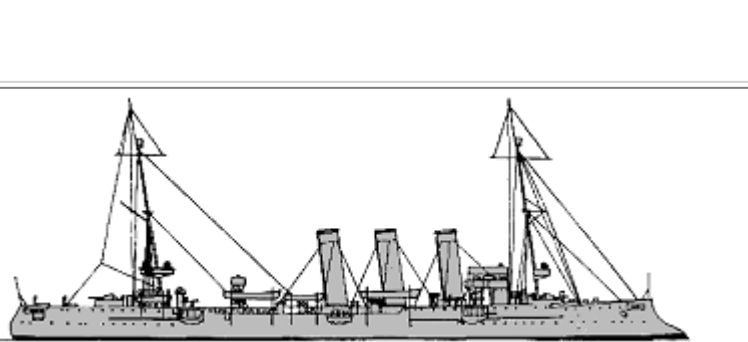
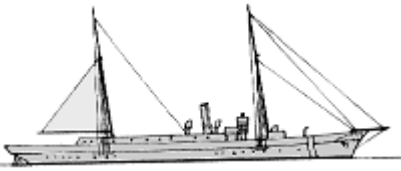
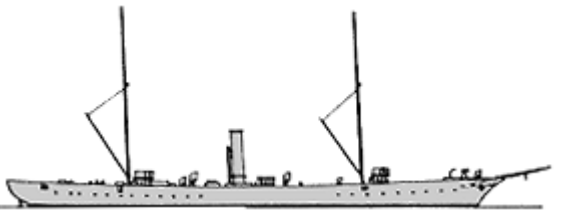

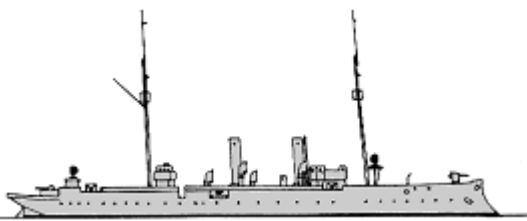
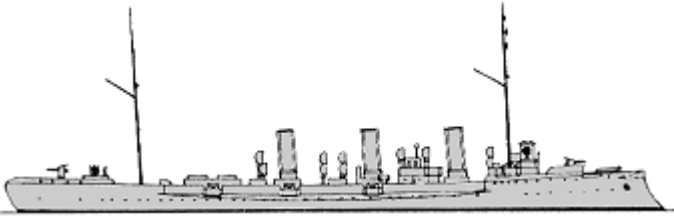
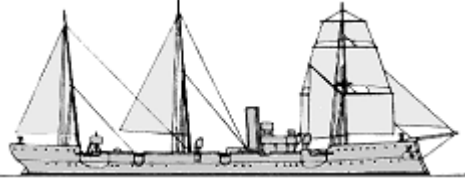
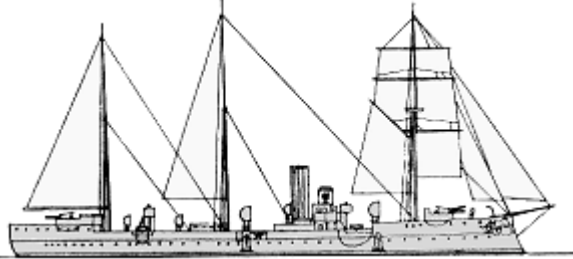
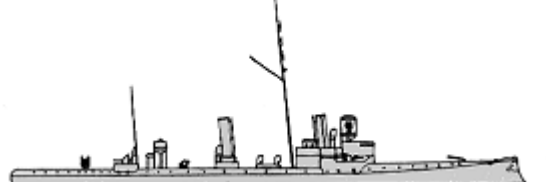
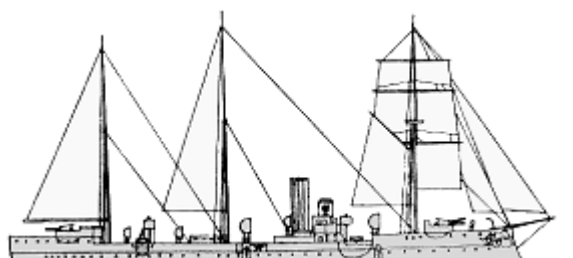
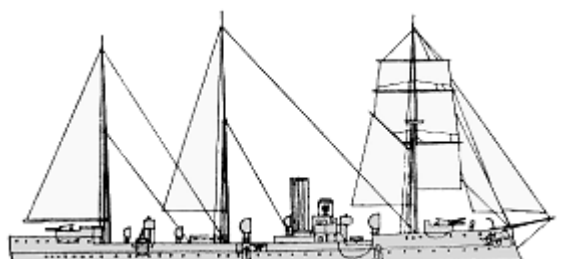

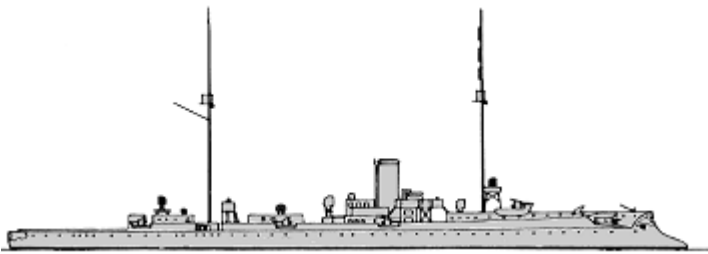
CA	Fürst Bismarck	1	1	Fürst Bismarck	1900		11461t, 127.0x20.4x8.5m, 12b,3vte, 13500hp, 18.7kts, 621p; 200belt, 30deck, 200turrets, 200CT; 2x2-238/37, 12x1-149/37, 10x1-88/27, 6-450TT		
	Prinz Heinrich	1	2	Prinz Heinrich	1902				9806t, 126.5x19.6x8.1m, 14b,3vte, 15000hp, 20kts, 567p; 100belt, 40deck, 150turrets, 150CT; 2x1-238/37, 10x1-149/37, 10x1-88/27, 4-450TT
	Prinz	2	3	Prinz Adalbert	1904				



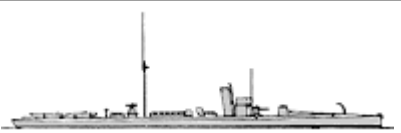

Gefion	1	12	Gefion	1894		4275t, 110.4x13.2x6.5m, 6b,2vte, 9000hp, 19kts, 212p; steel; 25slopes, 30deck, 30CT; 10x1-105/32, 6x1-50/37, 2x1-450TT
Victoria Louise	5	13	Victoria Louise	1899		6491(13-15)-6705(16,17)t, 110.6x17.4(13-15)-17.6(16,17)x6.8-7.3m, 12b,3vte(13-16)-18b,3vte(17), 10000hp, 19.5(13-15)-18.5(16,17)kts, 477p; 100slopes, 40deck, 100turrets, 150CT; 2x1-209/37, 8x1-149/37, 10x1-88/27, 3-450TT
		14	Hertha	1898		
		15	Freya	1898		
		16	Vineta	1899		
		17	Hansa	1899		
Gazelle	10	18	Gazelle	1900		2963(18,19)-3082(20-24)-3180(25-27)t, 105.0(18,19,25-27)-105.1(20-24)x12.2(18-24)-12.4(25-27)x5.5(18,19,25-27)-5.4(20-24)m, 8b,2vte(18,19)-10b,2vte(20)-9b,2vte(21-27), 6000(18)-8110(19)-9020(20-24)-8580(25-27)hp, 20(18)-22.1(19)-21.8(20-24)-21.5(25-27)kts, 249(18-24)-259(25-27)p; 50slopes, 25deck, 50shields, 80CT; 10x1-105/37, 3-450TT(18), 2-450TT(19-27)
		19	Niobe	1900		
		20	Nymphe	1900		
		21	Thetis	1901		
		22	Ariadne	1901		
		23	Amazone	1901		
		24	Medusa	1901		
		25	Frauenlob	1903		
		26	Arcona	1903		
		27	Undine	1904		
Bremen	2	28	Bremen	1904		3816t, 111.1x13.3x5.6m, 10b,2vte, 11750hp, 23kts, 288p; 80slopes, 35deck, 50shields, 100CT; 10x1-105/37, 2-450TT
		29	Hamburg	1904		
Grille	1	1	Grille	1858		491t, 56.9x7.4x3.2m, 2b,1hc, 760hp, 14.4kts, 70p; 1x1-125/21, 2x1-79/25, 6x5-37/20
Zieten	1	2	Zieten	1876		1170t, 79.4x8.6x4.6m, 6b,2hc, 2000hp, 16kts, 94p; 6x1-50/37
		3	Blitz	1883		

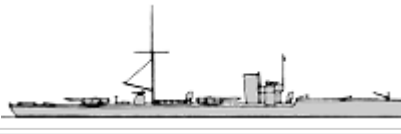

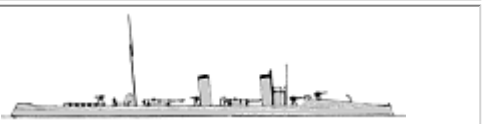
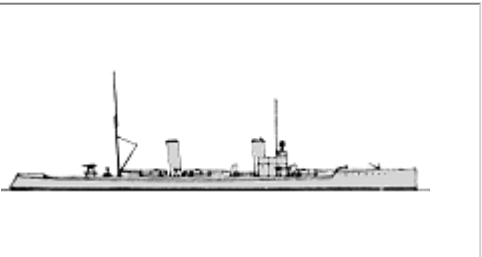
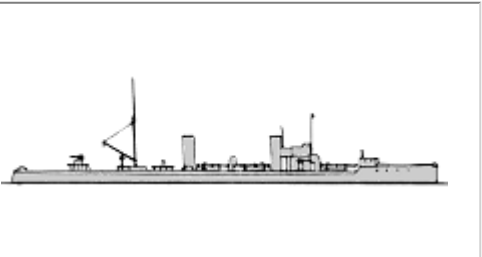
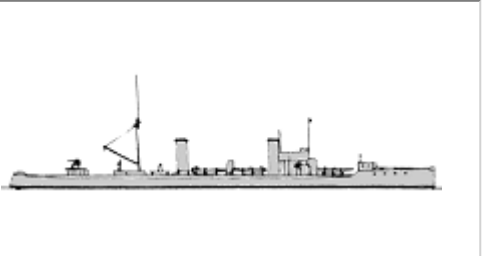
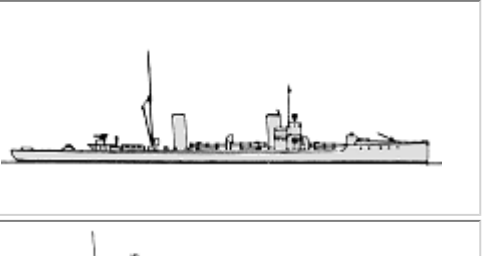
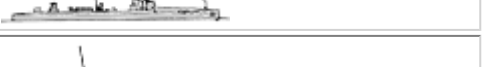

CLL	Blitz	2	4	Pfeil	1884		1486t, 78.4x9.9x4.4m, 8b,2hc, 2700hp, 15.6kts, 134p; 6x1-88/27, (2x1+1)-350TT
	Greif	1	5	Greif	1887		2266t, 102.6x9.8x4.3m, 6b,2hc, 5400hp, 18kts, 170p; 2x1-105/32, 8x1-88/27, 6x5-37/20
	Schwalbe	1	6	Sperber	1889		1359t, 66.9x9.4x4.7m, 4b,2hc, 1500hp, 13.5kts, 117p; 8x1-105/32, 5x5-37/20
	Bussard	2	7	Bussard	1890		1868t, 82.6x10.2x5.6m, 4b,2hte, 2800hp, 15.5kts, 161p; 8x1-105/32, 5x5-37/20, 2x1-350TT
			8	Falke	1891		
	Meteor	2	9	Meteor	1891		1078(9)-1117(10)t, 79.9x9.6x4.5m, 4b,2vte, 4500(9)-5000(10)hp, 19(9)-19.5(10)kts, 115p; steel; 25slopes, 15deck, 30CT; 4x1-88/27, 3-350TT
			10	Comet	1893		
	Seeadler	3	11	Seeadler	1892		1864t, 82.6x10.5x5.4m, 4b,2hte, 2800hp, 15.5kts, 161p; 8x1-105/32, 5x5-37/20, 2x1-350TT
		12	Condor	1892			
		13	Cormoran	1893			
Geier	1	14	Geier	1895		1918t, 83.9x10.6x5.2m, 4b,2hte, 2880hp, 15.5kts, 161p; 8x1-105/32, 5x5-37/20, 2x1-450TT	

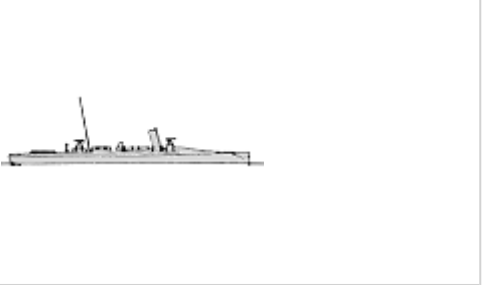
	Hela	1	15	Hela	1896		2082t, 105.0x11.0x4.6m, 6b,2vte, 6000hp, 20kts, 178p; steel; 25slopes, 20deck, 30CT; 4x1-88/27, 6x1-50/37, (1+2x1)-450TT
--	------	---	----	------	------	---	--



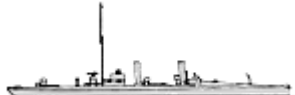

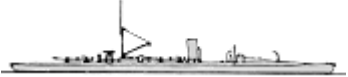
TORPEDO SHIPS

DD	D1	2	1	D1	1887		300t, 56.1x6.6x3.4m, 2b,1vte, 2000hp, 20.6kts, 46p; 3x1-50/37, (1+2x1)-350TT
			2	D2	1887		
	D3	2	3	D3	1888		300t, 57.6x6.8x3.2m, 2b,1vte, 2200hp, 20.3kts, 46p; 3x1-50/37, (1+2x1)-350TT
			4	D4	1888		
	D5	2	5	D5	1889		406t, 59.6x7.4x3.5m, 2b,1vte, 3200hp, 22.6kts, 46p; 3x1-50/37, (1+2x1)-350TT
			6	D6	1889		
	D7	2	7	D7	1891		410t, 59.7x7.4x3.4m, 2b,1vte, 3600hp, 22.5kts, 46p; 3x1-50/37, (1+2x1)-450TT
			8	D8	1891		
	D9	1	9	D9	1894		458t, 63.0x7.7x3.7m, 3b,1vte, 4200hp, 23.5kts, 52p; 3x1-50/37, (1+2x1)-450TT
	D10	1	10	D10	1898		371t, 66.1x6.0x2.4m, 3b,2vte, 5783hp, 27.2kts, 47p; 5x1-50/37, (1+2x1)-450TT
S90	12	11	S90	1899		394t, 63.0x7.0x2.8m, 3b,2vte, 5900hp, 27kts, 57p; 3x1-50/37(11-17,19-22), 1x1-50/37(18), 3x1-450TT(11-17,19-22)	
		12	S91	1900			
		13	S92	1900			
		14	S93	1900			
		15	S94	1900			
		16	S95	1900			
		17	S96	1900			
		18	Sleipner	1900			
		19	S98	1900			
		20	S99	1900			
21	S100	1901					

		22	S101	1901		
Taku	1	23	Taku	1898		284t, 59.0x6.4x2.6m, 4b,2vte, 5000hp, 27kts, 57p; 2x1-50/37, 2x1-450TT
S102	6	24	S102	1901		406t, 63.2x7.0x2.7m, 3b,2vte, 5900hp, 28kts, 57p; 3x1-50/37, 3x1-450TT
		25	S103	1901		
		26	S104	1901		
		27	S105	1901		
		28	S106	1901		
		29	S107	1902		
G108	6	30	G108	1902		440t, 65.8x6.7x2.9m, 3b,2vte, 6600hp, 28kts, 57p; 3x1-50/37, 3x1-450TT
		31	G109	1902		
		32	G110	1903		
		33	G111	1902		
		34	G112	1902		
		35	G113	1902		
S114	6	36	S114	1902		415t, 63.2x7.0x2.7m, 3b,2vte, 5900hp, 27kts, 57p; 3x1-50/37, 3x1-450TT
		37	S115	1903		
		38	S116	1903		
		39	S117	1903		
		40	S118	1903		
		41	S119	1903		
S120	5	42	S120	1904		468t, 64.7x7.0x2.6m, 3b,2vte, 6400hp, 27.5kts, 61p; 3x1-50/37, 3x1-450TT
		43	S121	1904		
		44	S122	1904		
		45	S123	1904		
		46	S124	1904		
Nr. XVIII	6	1-6	V1, 2, 5, 7-9	1884		61t, 32.8x3.8x1.8m, 1b,1vte, 590hp, 17.9kts, 14p; 2x5-37/20, 2-350TT
S7	17	7-23	S7-23	1885		98t, 37.7x4.9x2.2m, 1b,1vte, 725hp, 20.4kts, 16p; 1x1-50/37, (1+2x1)-350TT
S24	7	24	S24	1886		103t, 37.7x4.8x2.3m, 1b,1vte, 840hp, 19.1kts, 16p; 1x1-50/37, (1+2x1)-350TT
		25	S25	1886		
		26	S27	1886		
		27	S28	1886		
		28	S29	1886		
		29	S30	1887		
		30	S31	1887		
S32	1	31	S32	1886		119t, 39.1x5.3x2.5m, 1b,1vte, 900hp, 19.9kts, 20p; 1x1-50/37, (1+2x1)-350TT

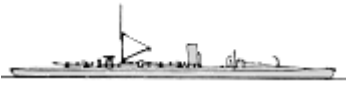
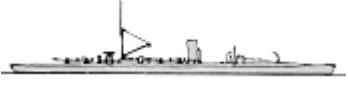
S33	8	32	S33	1887		113t, 39.9x4.8x2.3m, 1b,1vte, 1100hp, 20kts, 16p; 1x1-50/37, (1+2x1)-350TT
		33	S34	1887		
		34	S35	1887		
		35	S36	1887		
		36	S37	1887		
		37	S38	1887		
		38	S39	1887		
		39	S40	1887		
S42	1	40	S42	1889		153t, 44.2x5.0x2.6m, 1b,1vte, 1420hp, 22.2kts, 16p; 1x1-50/37, (1+2x1)-350TT
S43	14	41	S43	1889		152t, 44.2x5.0x2.7m, 1b,1vte, 1571hp, 21.5kts, 16p; 1x1-50/37, (1+2x1)-350TT
		42	S44	1889		
		43	S45	1889		
		44	S46	1889		
		45	S47	1889		
		46	S49	1890		
		47	S50	1890		
		48	S51	1890		
		49	S52	1890		
		50	S53	1890		
		51	S54	1890		
		52	S55	1890		
		53	S56	1890		
		54	S57	1890		
S58	8	55	S58	1892		152t, 44.3x5.0x2.6m, 1b,1vte, 1232hp, 20.2kts, 16p; 1x1-50/37, (1+2x1)-350TT
		56	S59	1892		
		57	S60	1892		
		58	S61	1892		
		59	S62	1892		
		60	S63	1892		
		61	S64	1892		
		62	S65	1892		
S66	1	63	S66	1893		172t, 47.9x5.4x2.7m, 2b,1vte, 1610hp, 22.1kts, 24p; 1x1-50/37, (1+2x1)-450TT
S67	7	64	S67	1893		166t, 47.9x5.4x2.6m, 1b,1vte, 1600hp, 21.9kts, 24p; 1x1-50/37, (1+2x1)-450TT
		65	S68	1893		
		66	S69	1893		
		67	S70	1893		
		68	S71	1893		

TB



			69	S72	1893		
			70	S73	1894		
S74	1	71	S74	1895		186t, 49.9x5.5x2.8m, 2b,1vte, 2500hp, 23.7kts, 24p; 1x1-50/37, (1+2x1)-450TT	
S75	7	72	S75	1895		180t, 49.0x5.3x2.9m, 2b,1vte, 1744hp, 22.3kts, 24p; 1x1-50/37, (1+2x1)-450TT	
		73	S76	1895			
		74	S77	1895			
		75	S78	1895			
		76	S79	1895			
		77	S80	1895			
S82	6	78	S81	1896		170t, 48.2x5.1x2.6m, 2b,1vte, 2146hp, 25.3kts, 29p; 1x1-50/37, (1+2x1)-450TT	
		79	S82	1897			
		80	S83	1897			
		81	S84	1897			
		82	S85	1898			
		83	S86	1898			
G88	2	84	S87	1898		177t, 48.7x5.0x2.8m, 2b,1vqe, 2468hp, 26kts, 29p; 1x1-50/37, (1+2x1)-450TT	
		85	G88	1898			
		86	G89	1898			
TSS	Ulan	1	1	Ulan	1876		438t, 38.0x8.0x4.6m, 4b,1vse, 800hp, 12kts, 41p; 3x5-37/20, 1-381TT

ESCORTS

PC	Sirius	4	1-4	Sirius, Vega, Castor, Pollux	1889-1890		52t, 22.6x4.6x1.6m, 1b,1vte, 200hp,; mines(4)
----	--------	---	-----	------------------------------	-----------	---	---

OTHER FIGHTING SHIPS

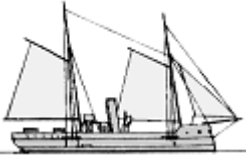
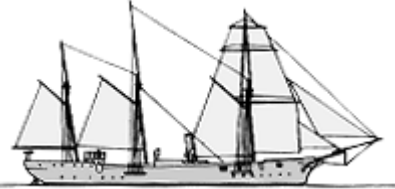
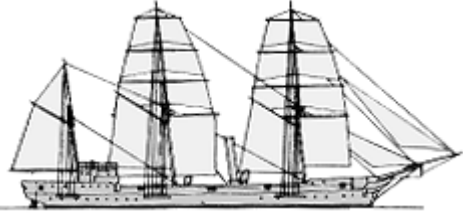
Wespe	11	1	Wespe	1876		1163t, 46.4x10.6x3.4m, 4b,2dc, 700hp, 10kts, 88p; iron- 203belt, 40deck, 203barbette, 20CT; 1x1-305/20, 2x1-87/22, 2x5-37/20, 2-350TT
		2	Viper	1877		
		3	Biene	1877		
		4	Mücke	1878		
		5	Scorpion	1877		
		6	Basilisk	1880		
		7	Camaeleon	1879		
		8	Crocodill	1880		
		9	Salamander	1880		
		10	Natter	1881		

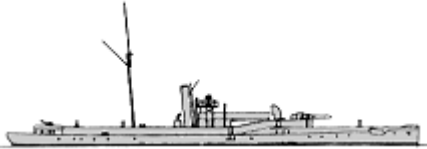
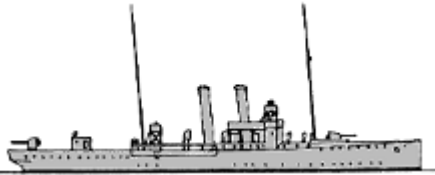
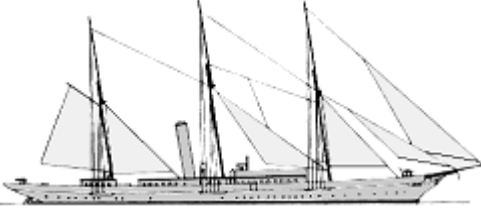
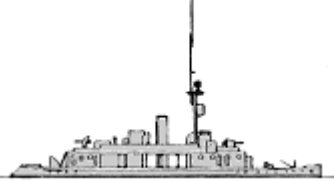
			11	Hummel	1881		
	Otter	1	12	Otter	1878		164t, 31.0x6.2x1.6m, 1b,2vse, 140hp, 8kts, 43p; small arms
PG	Wolf	2	13	Wolf	1878		570t, 47.2x7.7x3.4m, 2b,1hse, 340hp, 8.5kts, 106p; 2x1-125/21(14), 1x1-87/22(13), 2x1-87/22(14), 1x1-50/37(13), 2x5-37/20(13), 3x5-37/20(14)
			14	Hyäne	1879		
PG	Habicht	2	15	Habicht	1880		1005t, 59.2x8.9x4.2m, 2b,1hc, 600hp, 11kts, 127p; 5x1-125/21(15), 2x1-125/21(16), 5x5-37/20
			16	Möwe	1880		
	Hay	1	17	Hay	1882		247t, 34.0x6.4x2.8m, 2b,1vc, 202hp, 9.3kts, 40p; 2x1-88/27
	Brummer	1	18	Brummer	1884		929t, 64.8x8.5x4.8m, 2b,1dc, 1658hp, 14.1kts, 78p; compound- 160breastwork, 40deck; 1x1-209/28, 1x1-87/22
	Iltis	6	19	Iltis	1898		1031(19,20)-1090(21,22)-1193(23,24)t, 65.2(19-22)-66.9(23,24)x9.1(19-22)-9.7(23,24)x3.6(19,20)-3.7(21,22)-3.1(23,24)m, 4b,2hte(19,20)-4b,2vte(20-24), 1300hp, 14.5(19,20)-14(21-24)kts, 130p; 2x1-105/37(21-24), 4x1-88/27(19,20)
20			Jaguar	1899			
21			Tiger	1900			
22			Luchs	1900			
23			Panther	1902			
24			Eber	1903			
APG	-	1	1	Lorelei	1886		924t
PGR	Tsingtau	2	1	Tsingtau	1904		280t, 50.1x8.0x0.9m, 2b,2vte, 1300hp, 13kts, 47p; 1x1-88/27, 1x1-50/37
		2	2	Vaterland	1904		

APGR	-	1	1	Vorwärts	1899		406t
------	---	---	---	----------	------	--	------

AMPHIBIOUS SHIPS

LC	Pferdeboot	1	1	P.B.9 L.N.1	1904		14t, 10.5x3.4x0.6m, 1pe, 30hp, 13.5kts, 2p; 10t of cargo
----	------------	---	---	-------------	------	---	--

MINE WARFARE SHIPS

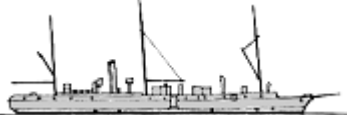
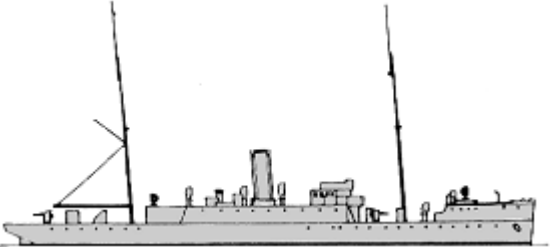
ML	Rhein	1	1	Rhein	1867		482t, 47.1x6.0x3.2m, 1b,1vse, 200hp, 9kts, 81p; 2x5-37/20, 100mines
	Pelikan	1	2	Pelikan	1891		2424t, 84.2x11.7x5.1m, 2b,2vte, 3000hp, 15kts, 195p; 4x1-88/27, 400mines

[home](#)[World navies yesterday](#)[1905](#)

Greece 01 January 1905

BATTLESHIPS

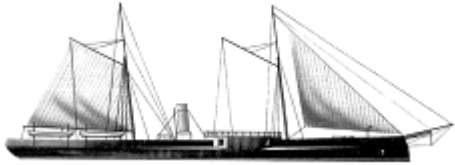
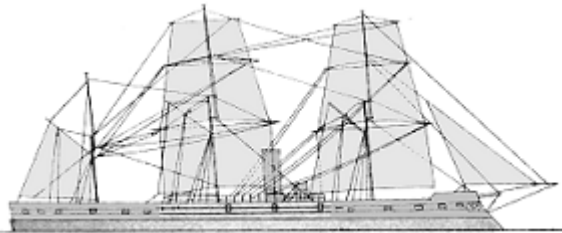
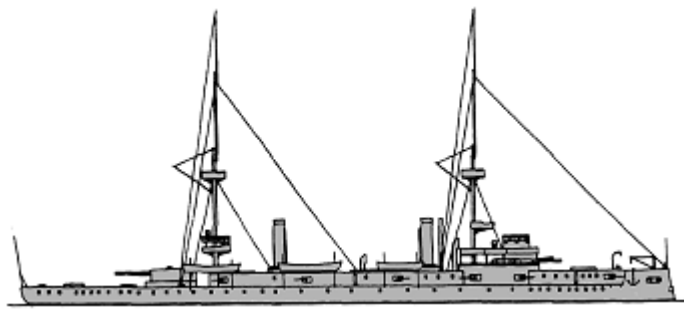
BC	Vasilefs Georgios	1	1	Vasilefs Georgios	1868		1774t, 61.0ppx10.1x4.9m, 4b,2vte, 3000hp, 14kts, 152p; iron- 178belt, 152battery, 25deck; 2x1-209/20, 1x1-149/27, 9x1-37/37
	Vasilissa Olga	1	2	Vasilissa Olga	1870		2030t, 76.0ppx11.9x5.8m, 4b,1vte, 4000hp, 16.5kts, 258p; iron- 152belt, 121battery, 25deck; 4x1-173/22, 2x1-173/17, 4x1-75/35, 4x5-37/17
	Idra	3	Idra	1892		1891	4885t, 102.0ppx15.8x5.5m, 4b,2vte, 6700hp, 17kts, 440p; steel, compound- 305belt, 57deck, 350casemate, 305barbette; 2x1-274/34, 1x1-274/28, 1x1-100/48, 8x1-65/50, 4x1-47/40, 10x5-37/17, 1-381TT, 2-356TT
4		Spetsai	1892				
5		Psara	1891				

CRUISERS

CLL	Navarchos Miaoulis	1	1	Navarchos Miaoulis	1879	No picture	1820t, 75.0ppx11.0x4.4m, 1hc, 2400hp, 13.5kts, 180p; 3x1-173/22, 1x1-173/17, 6x1-37/20, 3-356TT
-----	--------------------	---	---	--------------------	------	------------	---

TORPEDO SHIPS

TB	Ionia	1	1	No.18	1881	No picture	35t, 27.1x3.4x1.0m, 1b,1vc, 500hp, 17.5kts, 9p; 2-356TC
	Fereniki	5	2-6	No.1-5	1881	No picture	42t, 30.5x3.7x1.3m, 1b,1vc, 320hp, 16kts, 12p; 2-356TT, 1spar torpedo
	Samos	6	7-12	No.6-10, 17	1881	No picture	40t, 30.5x3.7x1.3m, 1b,1vc, 450hp, 19.5kts, 12p; 2x5-37/17, 2-356TT
	No11	5	13-17	No.11, 12, 14-16	1885		85t, 37.5x4.7x1.7m, 1b,1vc, 1000hp, 18kts, 20p; 1x5-37/17, (2+1x1)-356TT

OTHER FIGHTING SHIPS

PG	Afroessa	1	1	Plixavra	1857	No picture	380t, 38.0x7.0x2.7m, 160hp, 9kts; 1x1-87/22
	Salaminia	2	2	Paralos	1859	No picture	380t, 37.5x7.3x3.0m, 200hp, 8kts; 1x1-87/22
			3	Salaminia	1859		
	Sfaktiria	4	4-7	Alfa, Beta, Gamma, Delta	1880-1881	No picture	52t, 22.0x4.5x1.5m; 1x1-149/24, 1spar torpedo
	Hydra	2	8	Amvrakia	1881	No picture	470t, 39.0ppx7.9x2.2m, 2vc, 690hp, 12kts, 64p; 1x1-263/27, 1x1-149/27, 2x1-37/20, 1-356TT
			9	Aktion	1881		
	Achelaos	4	10	Achelaos	1884		400-420t, 41.0-42.0x7.4-7.6x3.5-4.0m, vc, 400hp, 9.8(10,11)-10.5(12,13)kts, 73p; 2x1-95/26, 2x1-37/20(10,11), 3x1-37/20(12,13)
			11	Alpheos	1884		
			12	Eurotas	1884		
			13	Peneos	1885		
Aidon	1	14	Aidon	1884	No picture	86t	
Kichli	2	15, 16	Kichli, Kissa	1884	No picture	86t, 24.2x4.9x2.1m, 1vc, 162hp, 10kts	

MINE WARFARE SHIPS

ML	Aigialeia	3	1	Aigialeia	1881	No picture	300t, 23.0x4.0x2.6m, 1vc, 300hp, 9kts; 20mines
			2	Monemvasia	1881		
			3	Nafplia	1881		
AML	-	1	1	Kanaris	1878		870t, 91.2x9.2m, 500hp, 14kts; 2x1-120/22, 2x5-37/17, 4-356TT, mines

© Ivan Gogin, 2014



[home](#)[World navies yesterday](#)[1905](#)

Haiti 01 January 1905

CRUISERS

CL	Dessalines	1	1	Dessalines	1883	No picture	1200t, 56.4x9.8x4.5m, 760hp, 16kts; 2x1-107/29, 1x1-100/26, 2x1-87/22
----	------------	---	---	------------	------	------------	---

OTHER FIGHTING SHIPS

PG	22 Décembre 1804	1	1	22 Décembre 1804	1860	No picture	900t, 63.4x9.1x4.9m, 360hp, 9kts; 4x1-121/22
	1804	1	2	1804	1875	No picture	600t, 44.2x8.8x3.1m, 100hp, 12kts; 6x1-121/22
	Saint Michael	1	3	Saint Michael	1875	No picture	850t, 49.4x10.7x3.4m, 120hp, 12kts; 1x1-279/12, 8x1-102/22
	Toussaint Louverture	1	4	Toussaint Louverture	1886		500t, 50.0ppx7.5x3.3m, 1vc, 790hp, 13kts; 1x1-165/28, 2x1-120/27
	Capois La Mort	2	5	Capois La Mort	1893		256t, 45.0x6.2x2.1m, 680hp, 14kts; 1x1-100/50, 4x1-37/20
			6	Alexander Pétion	1893		

© Ivan Gogin, 2015

[home](#)

[World navies yesterday](#)

[1905](#)

Honduras 01 January 1905

OTHER FIGHTING SHIPS

PG	Tatumbla	1	1	Tatumbla	1900s	No picture	200t, 12kts, 44p; 2x1-small guns
----	----------	---	---	----------	-------	------------	----------------------------------

COASTAL FORCES

YP	22 Februar	1	1	22 Februar	1897	No picture	13t, 22hp
----	------------	---	---	------------	------	------------	-----------

© Ivan Gogin, 2015

[home](#)[World navies yesterday](#)[1905](#)

Italy 01 January 1905

BATTLESHIPS

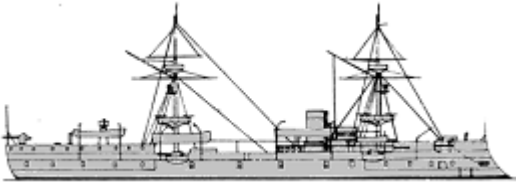
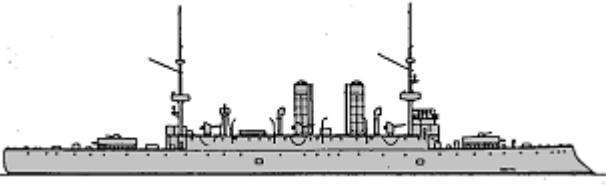
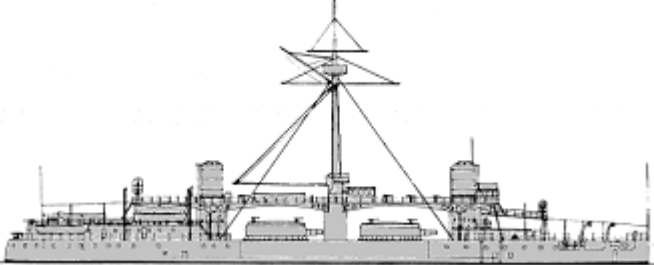
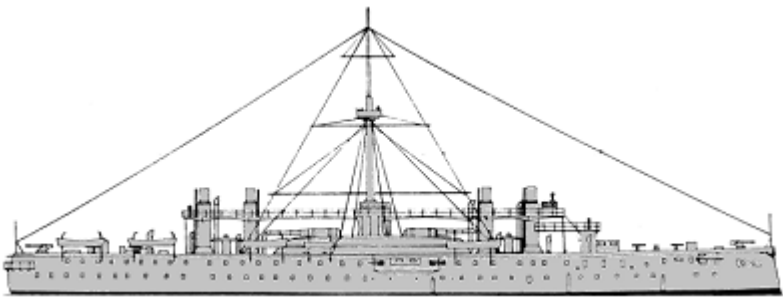
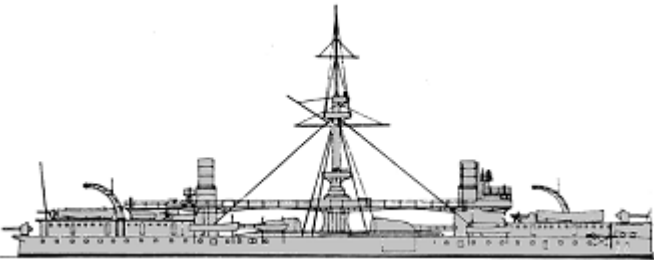
	Regina Maria Pia	1	1	Castelfidardo	1864		4527t, 81.8x15.2x6.4m, 8b,1hse, 2125hp, 12.1kts, 484p; iron, 110belt, 110battery; 1x1-76/40, 1x1-75/21, 4x1-57/43, 1x1-47/40, 2x5-37/20, 2-450TT
	Affondatore	1	2	Affondatore	1866		4307t, 93.8x12.2x6.4m, 8b,1hse, 3240hp, 12kts, 356p; iron, 127belt, 51deck, 127turrets, 127CT; 2x1-254/30, 6x1-120/24, 1x1-75/21, 8x1-57/40, 4x5-37/20, 2-450TT
	Duilio	2	3	Duilio	1880		12071(3)-11264(4)t, 109.2x19.7x8.3m, 8b,2vc, 7711(3)-8045(4)hp, 15(3)-15.6(4)kts, 420(3)-495(4)p; steel, 550belt, 50deck, 430(3)-225(4)turrets; 2x2-450/20(3), 2x2-254/40(4), 7x1-152/40(4), 3x1-120/40(3), 5x1-120/40(4), 2x1-76/40(3), 8x1-57/40(3), 16x1-57/43(4), 4x5-37/20(3), 8x5-37/20(4), 4x1-11.4/94(4), 3-350TT(3), 4-450TT(4), 1TB(3)
			4	Dandolo	1882		
	Italia	2	5	Italia	1885		15047(5)-15649(6)t, 124.7x22.5(5)-22.3(6)x8.8(5)-9.4(6)m, 24b,4vc, 11986(5)-15797(6)hp, 17.8(5)-18.4(6)kts, 669p; 2x2-432/26-27(5), 2x2-432/27(6), 8x1-152/32(6), 7x1-149/26(5), 4x1-120/32, 2x1-76/40, 6x1-57/40(5), 12x1-57/40(6), 10x5-37/20(5), 12x5-37/20(6), 2x1-11.4/94(5), 6-350TT(5), 4-350TT(6); 10000men
			6	Lepanto	1887		
BB	Ruggiero di Lauria	3	7	Ruggiero di Lauria	1888		10997(7)-11145(8)-11027(9)t, 105.9x19.8x8.3m, 8b,2vc, 10000-10500hp, 16-17kts, 507p; steel, 450belt, 75deck, 360barbettes, 250CT; 2x2-432/27, 2x1-153/32, 4x1-120/32, 2-350TT
			8	Francesco Morosini	1889		
			9	Andrea Doria	1891		

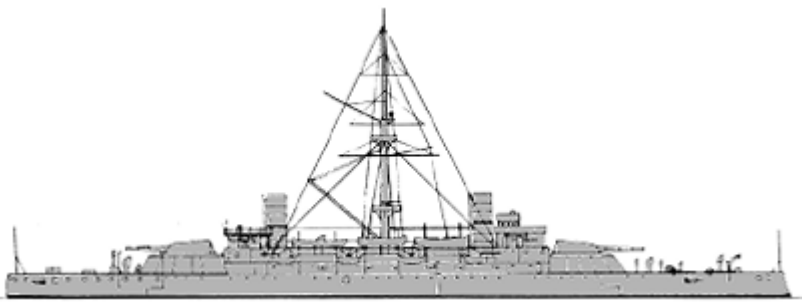
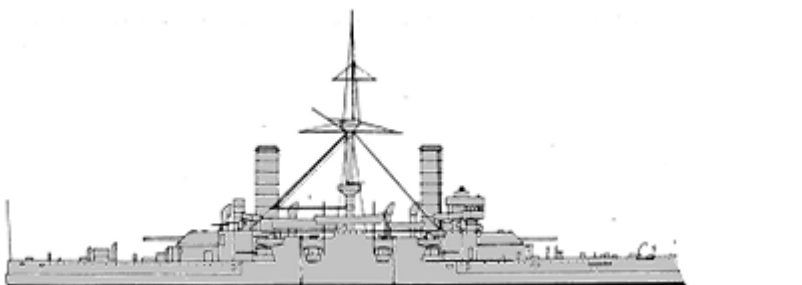
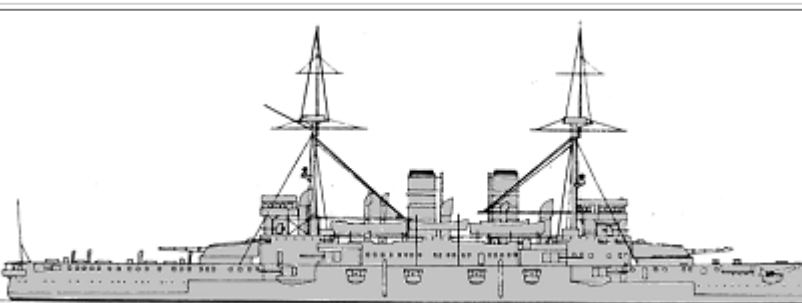
Re Umberto	3	10	Re Umberto	1893		15454(10)-14842(11)-15426(12)t, 127.6(10)-130.7(11,12)x23.4x9.3(10)-8.8(11,12)m, 18b,2vc(10,11)-18b,2vte(12), 17000(10)-19131(11)-22800(12)hp, 18.2(10)-20(11,12)kts, 733-794p; steel, 100belt, 75deck, 100turrets, 300CT; 2x2-343/30, 8x1-152/40, 16x1-57/43(10), 20x1-57/43(11,12), 10x1-37/25, 5-450TT
		11	Sicilia	1895		
		12	Sardegna	1895		
Ammiraglio di Saint Bon	2	13	Ammiraglio di Saint Bon	1901		9940-10531t, 111.8x21.1x7.7m, 12b,2vte, 14000hp, 18.2kts, 565p; Harvey, 250belt, 70deck, 250turrets, 250CT; 2x2-254/40, 8x1-152/40, 8x1-120/40, 6x1-76/40(14), 8x1-57/43(13), 8x1-47/40(14), 2x1-37/25(13), 4-450TT
		14	Emanuele Filiberto	1902		
Regina Margherita	1	15	Regina Margherita	1904		14093t, 138.7x23.8x8.8m, 28b,2vte, 21790hp, 20kts, 900p; Harvey, 150belt, 80deck, 200turrets, 150CT; 2x2-305/40, 4x1-203/45, 12x1-152/40, 20x1-76/40, 2x1-47/40, 2x1-37/25, 2x1-11.4/94, 4-450TT

CRUISERS

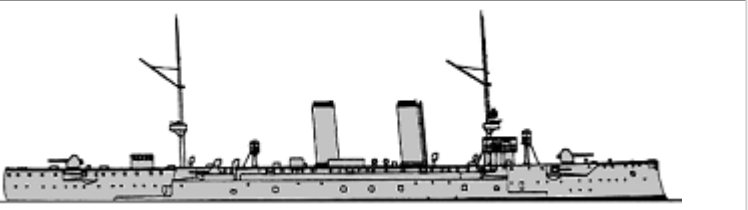
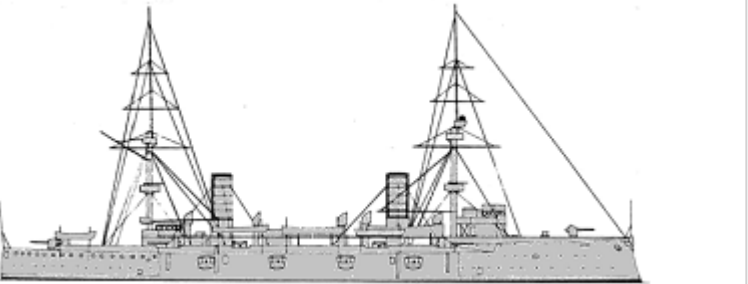

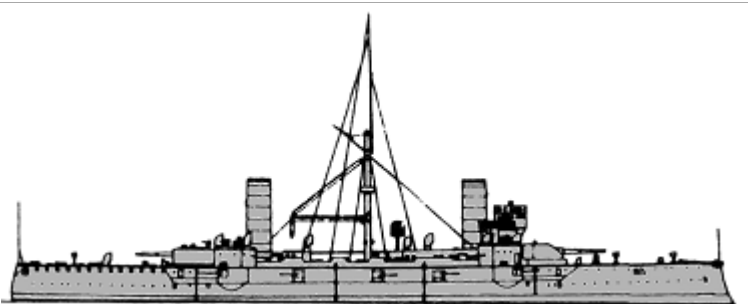
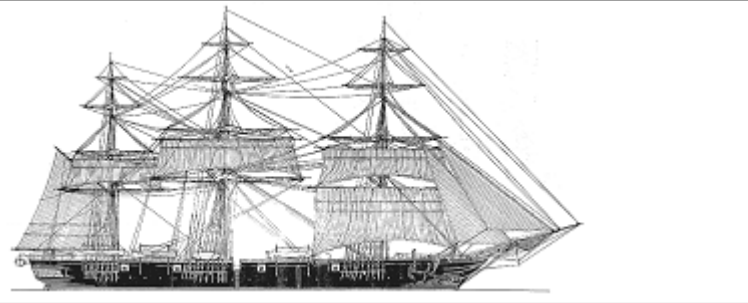
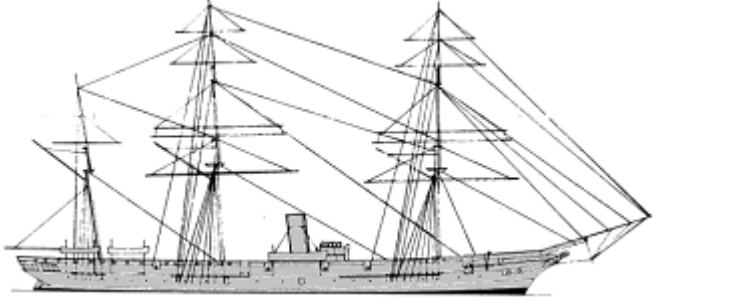
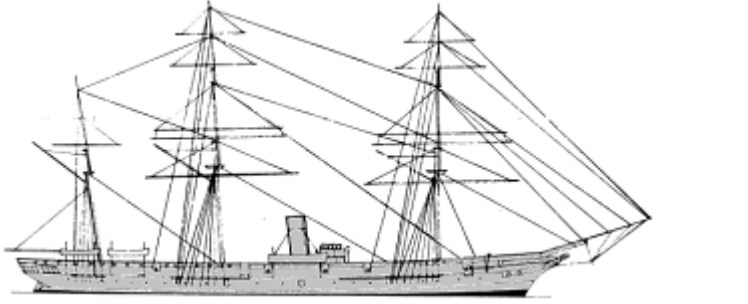
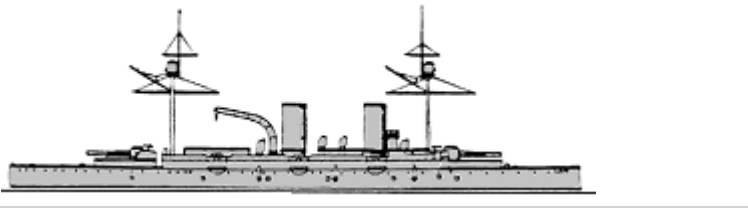
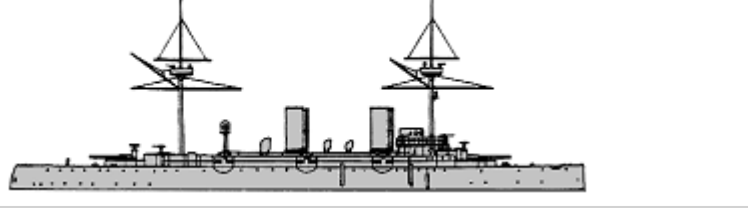

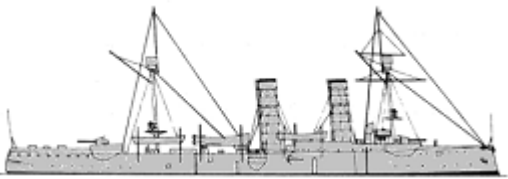
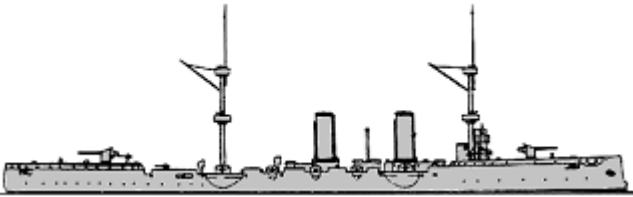
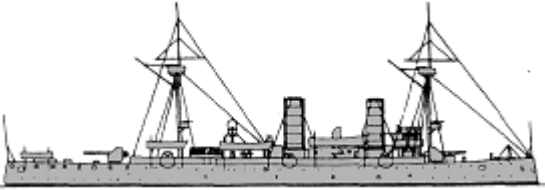
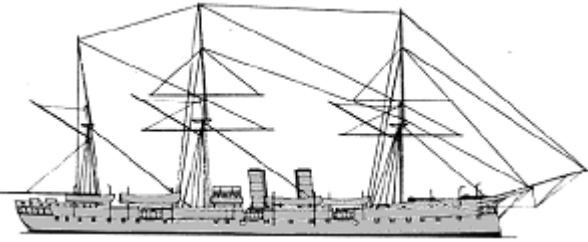
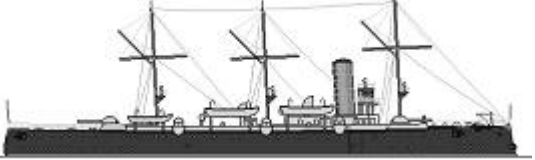
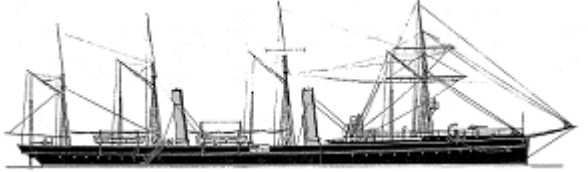
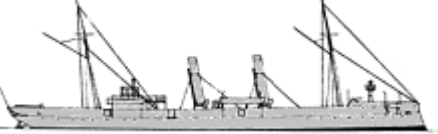
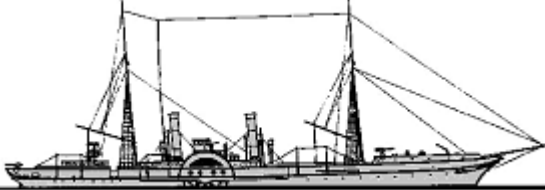
CA	Marco Polo	1	1	Marco Polo	1894		4820t, 106.1x14.7x5.9m, 4b,2vte, 10663t, 17.8kts, 402p; 100belt, 25deck, 50shields, 50CT; 6x1-152/40, 10x1-120/40, 2x1-75/21, 9x1-57/40, 2x1-37/25, 2x1-11.4/94, 5-450TT
				Carlo Alberto	1898		
	Vettor Pisani	2	3	Vettor Pisani	1899		7057(2)-7128(3)t, 105.7x18.0x7.2m, 8b,2vte, 13219(2)-13259(3)hp, 19.1(2)-18.6(3)kts, 486p; Harvey, 150belt, 37deck, 150casemates, 150CT; 12x1-152/40, 6x1-120/40(2), 4x1-120/40(3), 2x1-75/21, 14x1-57/40, 6x1-37/25(2), 8x1-37/25(3), 2x1-11.4/94, 4-450TT
				Varese	1901		
Garibaldi	2		Giuseppe			7972t, 111.8x18.3x7.1m, 24b,2vte, 13500hp, 19.5kts, 559p; 150belt, 38deck, 150turrets, 150CT; 1x1-254/40, 1x2-203/45, 14x1-152/40, 10x1-76/40, 6x1-47/40, 4-450TT	







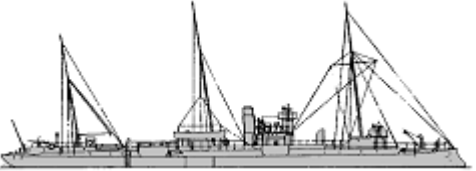
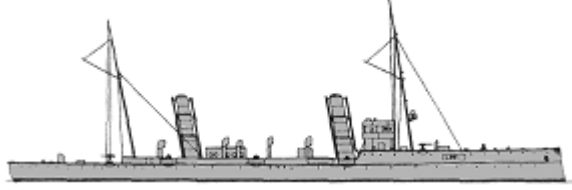







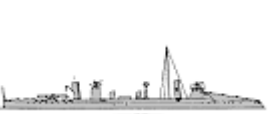

			5	Garibaldi	1901		
	Caracciolo	1	1	Caracciolo	1870		1661t, 64.3ppx10.9x5.0m, sails, 247p; 2x1-75/21, 4x1-57/40
	Flavio Gioia	1	2	Flavio Gioia	1883		3064t, 84.5x12.8x5.2m, 8b,1hr, 4156hp, 14kts, 268p; steel, deck; 4x1-120/40, 2-350TT
	Amerigo Vespucci	1	3	Amerigo Vespucci	1884		2751t, 84.5x12.8x5.5m, 8b,1hr, 3000hp, 13kts, 268p; 4x1-120/40, 4x1-57/40, 2x1-37/20, 2-350TT
	Giovanni Bausan	1	4	Giovanni Bausan	1885		3277t, 89.3x12.9x6.0m, 4b,2vde, 6470hp, 17.4kts, 295p; compound, 38deck, 13CT; 2x1-254/30, 6x1-152/40, 4x1-57/40, (6x5+3x1)-37/20, 2x1-11.4/94, 2-350TT
CL	Etna	4	5	Etna	1887		3737-3888t, 91.4x13.2x5.8m, 4b,2vde, 6252-7480hp, 16.6-18kts, 308p; compound, 38deck, 13CT; 2x1-254/30, 6x1-152/32(5-7), 6x1-152/40(8), 5x1-57/40(5-7), 6x1-57/40(8), (1x5+5x1)-37/20(5-7), 8x1-37/20(8), 2x1-11.4/94, 2-350TT(4-7), 3-350TT(8)
			6	Vesuvio	1888		
			7	Stromboli	1888		
			8	Ettore Fieramosca	1889		

						2050t, 76.2x11.3x4.4m, 4b,2vte, 5012hp, 17.7kts, 224p; compound, 51deck, 114shields, 51CT; 6x1-152/32, 9x1-57/40, 6x5-11.4/94, 4-350TT
						2597t, 97.8x11.6x4.9m, 4b,2vte, 7100hp, 20.4kts, 298p; compound, 76deck, 114shields, 76CT; 2x1-152/40, 10x1-120/40, 10x1-57/40, 6x1-37/20, 4x1-11.4/94, 2-350TT
						
		11	Umbria	1894		
		12	Lombardia	1893		
		13	Etruria	1894		
		14	Liguria	1894		
		15	Elba	1896		
		16	Puglia	1901		2411-2750(11-14,16)-2950(15)t, 84.8(11-14)-88.2(15)-88.3(16)x12.0(11-14)-12.7(15)-12.0(16)x4.7-5.5m, 4b,2hte(11-15)-4b,2vte(16), 6842-7677hp, 17-19.8kts, 213-278p; Harvey, 50(11-15)-25(16)deck, 50CT; 4x1-152/40, 6x1-120/40, 1x1-75/21(11), 7x1-57/40(11), 10x1-57/40(12), 8x1-57/40(13-16), 9x1-37/25(11), 2x1-37/25(13,14), 6x1-37/25(15), 8x1-37/25(16), 2-450TT
						2713t, 76.4ppx11.3x5.7m, 6b,1hc, 2321hp, 13kts, 238p; 8x1-120/40
						2660t, 81.0x12.7x5.1m, 4b,2vte, 4260hp, 16.4kts, 254p; 50deck, 50CT; 4x1-152/40, 6x1-120/40, 8x1-57/40, 8x1-37/25, 2-450TT
						1523t, 81.1x9.3x3.8m, 4b,1vde, 1920hp, 13.5kts, 144p; 5x1-57/43, 2x1-11.4/94
						
		2	Agostino Barbarigo	1879		
		3	Marcantonio Colonna	1880		805(2)-770(3)t, 68.1x7.4x3.4m, 4b,1vte, 1704-1760hp, 15kts, 104p; 5x1-57/43, 2x1-25/41
SL						1137t, 72.0ppx9.1x3.2m, 4b,1hse(sw), 1797hp, 14kts, 107p; 4x1-57/43, 4x5-37/20
		5	Galileo Galilei	1888		

Archimede	2					886(5)-950(6)t, 77.0x8.0x3.8m, 4b,1vte, 1384-1411hp, 12kts, 73p; 4x1-120/24, 2x1-57/43, 2x5-37/20
	6	Archimede	1888			

TORPEDO SHIPS

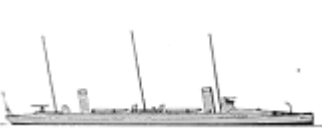
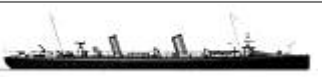
PGT	Tripoli	1	1	Tripoli	1886		952t, 73.4x7.9x3.7m, 6b,3de, 2500hp, 17.5kts, 111p; steel, 40deck; 1x1-76/40, 6x1-57/40, 1x1-47/40, 3-350TT
	Folgore	1	2	Saetta	1888		394t, 56.7x6.3x2.2m, 4b,2vde, 2150hp, 17kts, 70p; 1x1-76/40, 2x1-57/43, 2x1-57/40, 2x1-47/40, 1x5-37/20
	Goito	2	3	Goito	1888		955-974t, 73.4x7.9-8.0x3.0-3.6m, 6b,2vde(3)-6b,3vte(4), 2500(3)-3180(4)hp, 18(4)-17(3)kts, 121p; steel, 40deck; 6x1-57/40(4), 5x1-57/40(3), (3x5+2x1)-37/20(3), 2x1-37/20(4), 4-350TT(4), 60mines(3)
			4	Montebello	1889		
	Partenope	8	5	Partenope	1890		821-931t, 73.1x8.2x3.5m, 4b,2vte, 3884-4422hp, 18.1-20.8kts, 121p; 1x1-120/40(5-10,12), 2x1-120/40(11), 6x1-57/43(5-10,12), 4x1-57/43(11), 3x1-37/20(5-10,12), 2x1-37/20(11), (1+4x1)-450TT(5), (2+4x1)-450TT(6-12)
			6	Minerva	1892		
			7	Euridice	1891		
			8	Urania	1893		
			9	Iride	1892		
			10	Aretusa	1892		
			11	Caprera	1895		
	Agordat	2	13	Agordat	1900		1340-1292t, 91.6x9.3x3.6m, 8b,2vte, 7500(13)-8000(14)hp, 22(13)-22.5(14)kts, 185p; steel, 20deck; 12x1-76/40, 2x1-450TT
			14	Coatit	1900		
	DD	Fulmine	1	1	Fulmine	1900	
Lampo		6	2	Lampo	1900		348t, 62.1x6.5x2.6m, 4b,2vte, 5230-5998hp, 30kts, 61p; 1x1-76/40(2-4,6), 5x1-57/43(2-4,6), 6x1-57/43(5,7), 2x1-350TT
			3	Freccia	1902		
			4	Dardo	1901		
			5	Strale	1901		
			6	Euro	1901		
Nembo		4	7	Ostro	1901		380t, 64.0x5.9x2.3m, 3b,2vte, 5200-5350hp, 30kts, 58p; 1x1-76/40(8,9), 5x1-57/43, 2x1-350TT(8,9), (1+3x1)-350TT(10,11)
			8	Nembo	1902		
			9	Turbine	1902		
					10	Aquilone	1903

							
		11	Borea	1903			
TB	Aquila	2	1, 2	23T, 24T	1882		35t, 29.2x3.3x1.5m, 1b,1vde, 475hp, 20kts, 11p; 1x2-25/41, 2-350TT
	Aldebaran	9	3-11	26T, 28T, 30T-35T, 40T	1882-1885		39t, 30.6x3.6x1.7m, 1b,1vde, 430-455hp, 21kts, 11p; 1x2-25/41, 2-350TT
	Arturo	4	12-15	38T, 46T, 50T, 51T	1885-1887		39t, 30.6x3.6x1.7m, 1b,1vde, 430-455hp, 21kts, 11p; 1x2-25/41, 2-350TT
	Vega	6	16-21	36T, 41T, 44T, 45T, 52T, 53T	1885-1888		39t, 30.6x3.6x1.7m, 1b,1vde, 430hp, 21kts, 11p; 1x2-25/41, 2-350TT
	Procione	5	22-26	37T, 48T, 49T, 54T, 55T	1885-1887		39t, 30.6x3.6x1.7m, 1b,1vde, 390-430hp, 21kts, 11p; 1x2-25/41, 2-350TT
	Acquario	1	27	43T	1885		39t, 30.6x3.6x1.7m, 1b,1vde, 387-430hp, 21kts, 11p; 1x2-25/41, 2-350TT
	56S	17	28-44	81S-85S, 99S-104S, 106S-111S	1886-1887		78t, 39.8x4.8x2.0m, 1b,1vde, 902-1080hp, 21-22kts, 17p; 2x1-37/20, 2-350TT(39-50), (1+1x1)-350TT(51-55)
	76Ya	4	45	76Ya	1887		108t, 41.2x4.3x1.5m, 2b,2vde, 1600-1640hp, 26(45,46)-22(47,48)kts, 20p; 2x5-37/20, (2+1x2)-350TT(45,46), (2+1x1)-350TT(47,48)
			46	77Ya	1887		
			47	78Ya	1895		
			48	79Ya	1896		
	72S	34	49-82	72S-75S, 93S-98S, 105S, 112S-123S, 128S-131S, 136S-138S, 147S-150S	1887-1895		78t, 39.8x4.8x2.0m, 1b,1vde(49-51,53-55,57-82)-2b,1vde(52,56), 902-1080hp, 21-22kts, 17p; 2x1-37/20(49-58), 2x1-37/25(59-82), 2-350TT(49-58), (1+1x1)-350TT(59-82)
	68S	11	83-93	68S-71S, 116S-119S, 146S, 153S, 154S	1887-1894		78t, 39.8x4.8x2.0m, 1b,1vde, 723-1946hp, 21-22kts, 17p; 2x1-37/20(83-86), 2x1-37/25(87-93), 2-350TT(83-86), (1+1x1)-350TT(87-93)
	66S	2	94, 95	66S, 67S	1888		78t, 39.8x4.8x2.0m, 1b,1vde, 902-1080hp, 21-22kts, 17p; 2x1-37/20, 2-350TT
60S	16	96-111	60S-65S, 112S-115S, 132S-135S, 151S, 152S	1888-1894		78t, 39.8x4.8x2.0m, 1b,1vde(96-107,109-111)-2b,1vde(108), 683-1082hp, 21-22kts, 17p; 2x1-37/20(96-101), 2x1-37/25(102-111), 2-350TT(96-101), (1+1x1)-350TT(102-111)	
56S	18	112-129	80S, 86S-92S, 124S-127S, 139S-144S	1888-1893		78t, 39.8x4.8x2.0m, 1b,1vde, 782-1079hp, 21-22kts, 17p; 2x1-37/20(112-119), 2x1-37/25(120-129), 2-350TT(112-119), (1+1x1)-350TT(120-129)	
Aquila	5	130	Aquila	1888		137t, 47.6x5.1x2.2m, 2b,2vde, 2180hp, 24kts, 24p; 2x1-37/25, (1+2x1)-350TT	
		131	Sparviero	1888			
		132	Falco	1888			
		133	Nibbio	1888			
		134	Avvoltoio	1888			
Condore	1	135	Condore	1900		138t, 48.0x5.6x1.4m, 2b,2vte, 2370hp, 26kts, 31p; 2x1-37/25, 2x1-350TT	
Pellicano	1	136	Pellicano	1900		181t, 48.7x5.7x1.5m, 3b,2vte, 2740hp, 21kts, 30p; 2x1-37/25, 2x1-350TT	

SUBMARINES

SS	Delfino	1	1	Delfino	1895		102/113t, 24.7x2.9x2.8m, 1pe/em, 130/65hp, 10/5kts, 11p, 30m; 1-450TT
----	---------	---	---	---------	------	---	---

OTHER FIGHTING SHIPS

	Curtatone	1	Voltorno	1889		1155(1)-1039(2)t, 54.1ppx9.9x4.5m, 3b,1vc, 1110(1)-1043(2)hp, 11.4(1)-10.7(2)kts, 144p; 4x1-120/32(1), 4x1-57/43(1), 6x1-57/43(2), 2x1-37/25	
		2	Curtatone	1890			
PG	Castore	1	3	Polluce	1891		522t, 35.1x11.3x2.5m, 2b,1vc, 364hp, 8kts, 49p; 1x1-120/40, 1x1-11.4/94
	Governolo	1	4	Governolo	1896		1203t, 56.4ppx10.3x4.6m, 3b,1vc, 1100hp, 14kts, 137p; 4x1-120/32, 4x1-57/43, 2x1-37/25, 2x1-11.4/94, 1-450TT

MINE WARFARE SHIPS

ML	Castore	1	1	Castore	1889		522t, 35.1x11.3x2.5m, 2b,1vc, 364hp, 8kts, 49p; 20mines
AML	-	1	1	Betta N.3	1891		580t; mines

[home](#)[World navies yesterday](#)[1905](#)

Japan 01 January 1905

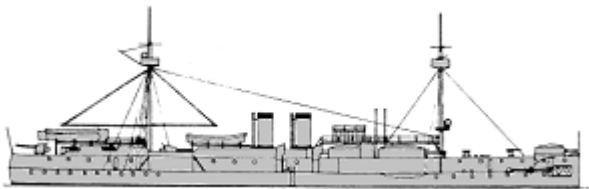
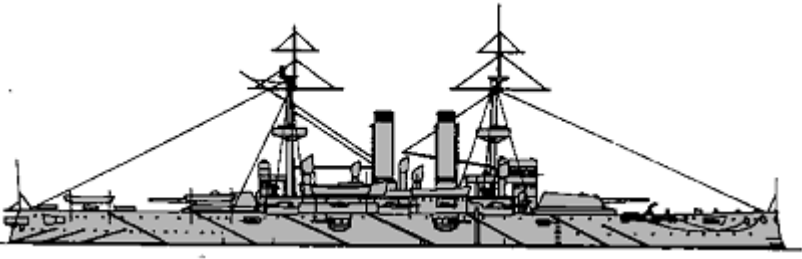
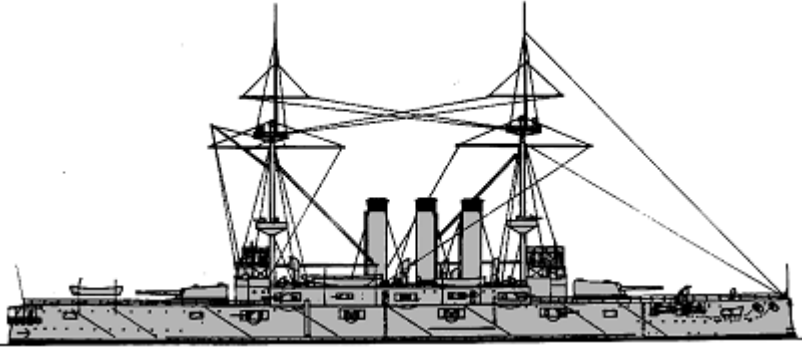
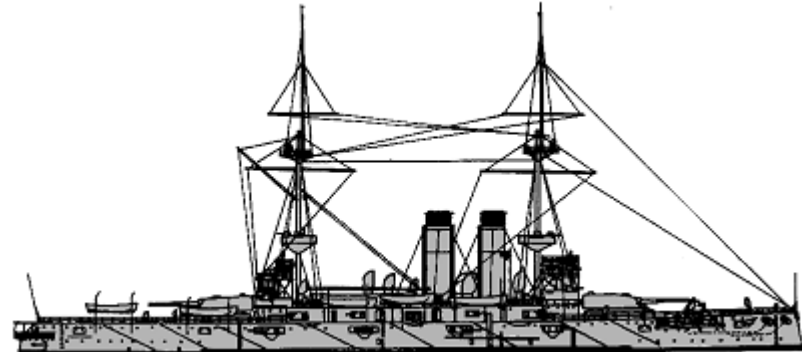

BATTLESHIPS

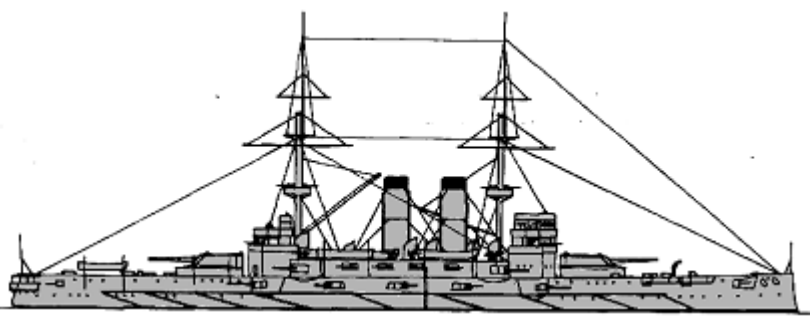
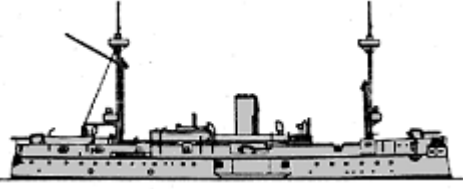
BB	Chin Yen	1	1	Chin Yen	1885		7670t, 93.9x18.0x6.1m, 8b,2hc, 6300hp, 14.5kts, 329p; steel-356belt, 76deck, 305turrets, 203CT; 2x2-305/22, 4x1-152/40, 2x1-57/43, 8x1-47/40, 3-350TT, 2tb
	Fuji	1	2	Fuji	1897		12533t, 125.5x22.2x8.1m, 10b,2vte, 14000hp, 18kts, 741p; Harvey- 457belt, 63deck, 152turrets, 356CT; 2x2-305/40, 10x1-152/40, 16x1-76/40, 4x1-47/40, 4x1-47/30, 5-450TT
	Shikishima	1	3	Shikishima	1900		15453t, 133.5x23.0x8.3m, 25b,2vte, 14500hp, 18kts, 836p; Harvey- 229belt, 102deck, 254turrets, 356CT; 2x2-305/40, 14x1-152/40, 20x1-76/40, 6x1-47/40, 6x1-47/30, 5-450TT
	Asahi	1	4	Asahi	1900		15374t, 129.6x22.9x8.3m, 25b,2vte, 15000hp, 18kts, 830p; Harvey- 229belt, 102deck, 254turrets, 356CT; 2x2-305/40, 14x1-152/40, 20x1-76/40, 6x1-47/40, 6x1-47/30, 4-450TT

	Mikasa	1	5	Mikasa	1902		15179t, 131.7x23.2x8.3m, 25b,2vte, 15000hp, 18kts, 830p; Harvey- 229belt, 76deck, 254turrets, 356CT; 2x2-305/40, 14x1-152/40, 20x1-76/40, 8x1-47/40, 4x1-47/30, 4-450TT
BC	Fuso	1	1	Fuso	1878		3717t, 68.9x14.6x5.5m, 8b,2htc, 3500hp, 13kts, 250p; iron- 229belt, 229battery; 4x1-235/20, 2x1-152/50, 4x1-120/40, 10x1-47/40, 4x4-25/60, 2-350TT

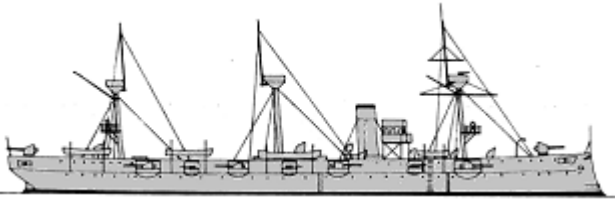
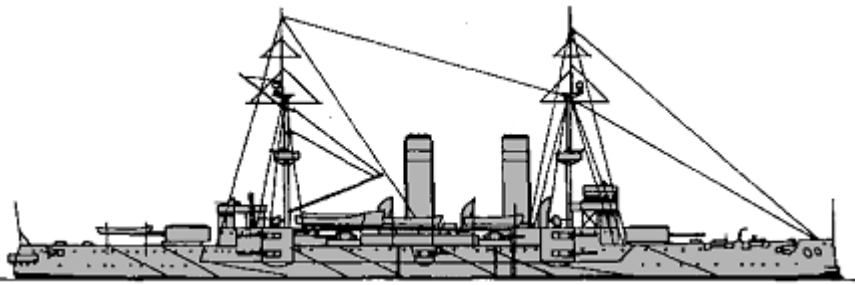
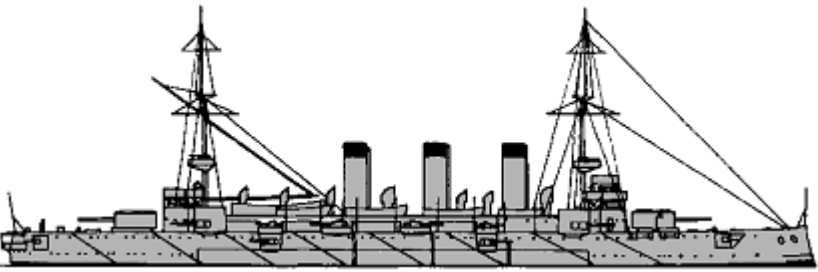
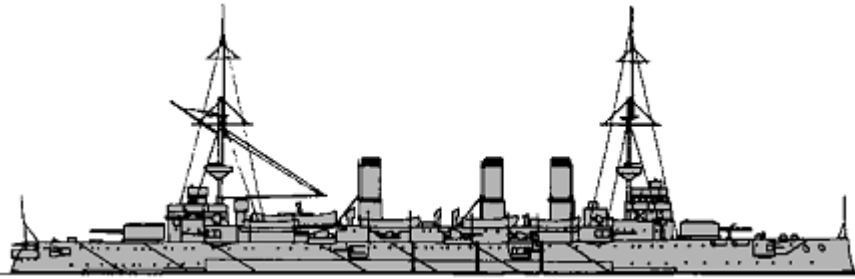

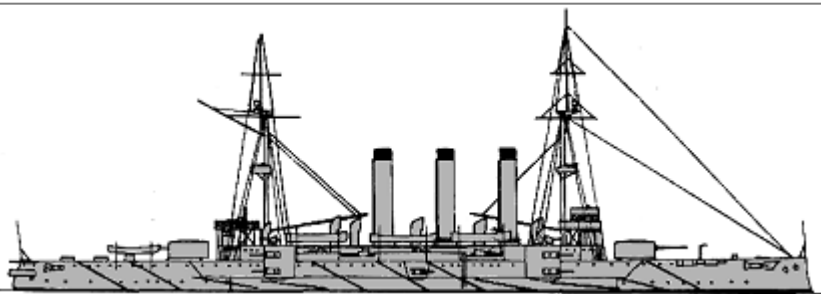
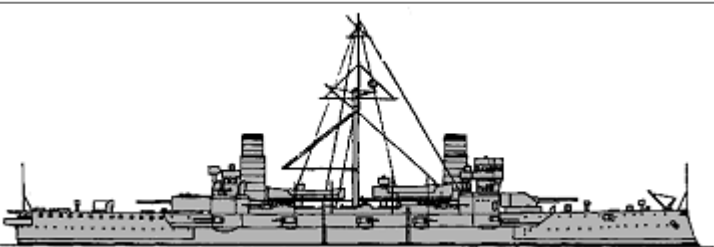
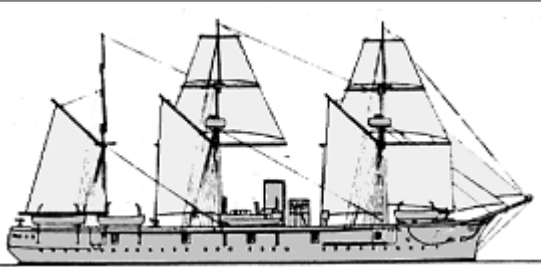
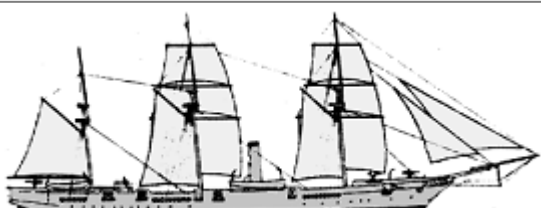
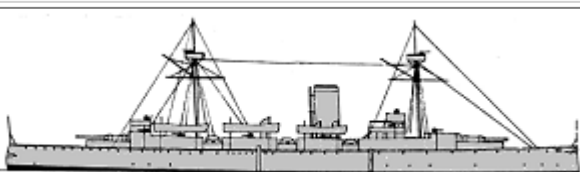
CRUISERS

CA	Chiyoda	1	1	Chiyoda	1891		2439t, 94.5x12.8x4.3m, 12b,2vte, 5600hp, 19kts, 350p; compound- 92belt, 35deck, 30CT; 10x1-120/40, 14x1-47/40, 3x10-11.4/94, 3-350TT
	Asama	2	2	Asama	1899		10500t, 134.7x20.5x7.4m, 12b,2vte, 18000hp, 21.5kts, 726p; Harvey- 178belt, 76deck, 152turrets, 356CT; 2x2-203/45, 14x1-152/40, 12x1-76/40, 7x1-47/30, 5-450TT
			3	Tokiwa	1899		
	Yakumo	1	4	Yakumo	1900		10300t, 132.3x19.6x7.2m, 24b,2vte, 15500hp, 20.5kts, 700p; 178belt, 63deck, 152turrets, 356CT; 2x2-203/45, 12x1-152/40, 12x1-76/40, 7x1-47/30, 5-450TT
Adzuma	1	5	Adzuma	1900		9953t, 137.9x20.9x7.2m, 24b,2vte, 17000hp, 20kts, 650p; 178belt, 63deck, 152turrets, 356CT; 2x2-203/45, 12x1-152/40, 12x1-76/40, 12x1-47/40, 5-450TT	

Idzumo	2	6	Idzumo	1900		10300t, 132.3x20.9x7.4m, 24b,2vte, 14500hp, 20.8kts, 672p; 178belt, 63deck, 152turrets, 356CT; 2x2-203/45, 14x1-152/40, 12x1-76/40, 8x1-47/30, 4-450TT
		7	Iwate	1901		
Kasuga	2	8	Kasuga	1904		8500t, 111.7x18.9x7.3m, 12b,2vte, 13500hp, 20kts, 600p; 150belt, 38deck, 150turrets, 150CT; 1x1-254/40(8), 1x2-203/45(8), 2x2-203/45(9), 14x1-152/40, 10x1-76/40, 6x1-47/40(8), 4x1-47/40(9), 4-450TT
		9	Nisshin	1904		
Kongo	2	1	Kongo	1878		3718t, 70.5x12.5x5.5m, 6b,1hc(1)-2b,1hc(2), 2490hp, 14kts, 314p; compound- 114belt; 3x1-173/17, 6x1-149/22, 2x1-75/11, 2x1-47/40, 4x4-25/60, 2x5-11.4/94, 2-350TT
		2	Hiei	1878		
Kaimon	1	3	Tenryu	1884		1525t, 64.7x10.8x5.2m, 4b,1hcra, 1267hp, 12kts, 214p; 1x1-173/22, 1x1-149/22, 4x1-120/22, 1x1-79/25, 4x4-25/60
Naniwa	2	4	Naniwa	1885		3708t, 97.5x14.0x6.1m, 6b,2hc, 7000hp, 18.5kts, 325p; steel- 76deck, 51barbettes, 38CT; 8x1-152/40, 6x1-47/40, 4-350TT
		5	Takachiho	1886		
Katsuragi	3	6	Katsuragi	1887		1502t, 62.8x10.7x4.6m, 6b,1hcra, 1622hp, 13kts, 231p; 2x1-173/22, 5x1-120/22, 1x1-79/25, 8x1-47/30, 4x4-25/60, 2-450TT
		7	Yamato	1888		
		8	Musashi	1887		
Itsukushima	3	9	Itsukushima	1891		4217t, 99.8x15.4x6.0m, 8b,2hte, 5400hp, 16.5kts, 360p; Harvey- 40deck, 100turret, 125CT; 1x1-320/38, 11x1-120/40(9,11), 12x1-120/40(10), 5x1-57/40(9), 6x1-57/40(10,11), 12x1-37/20(9), 11x1-37/20(10,11), 4-350TT
		10	Matsushima	1892		
		11	Hashidate	1894		

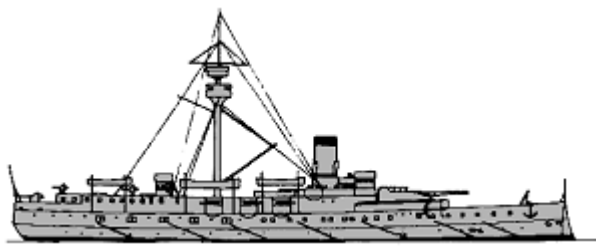
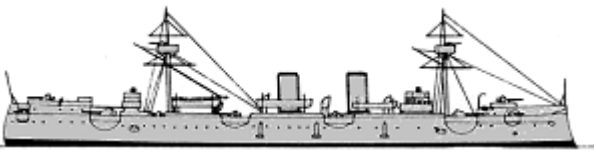
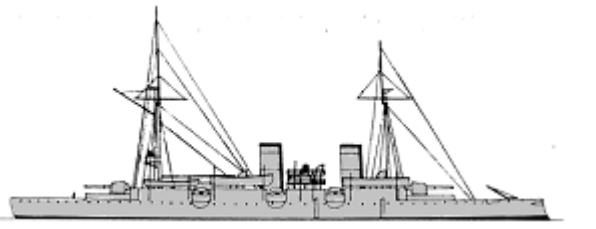
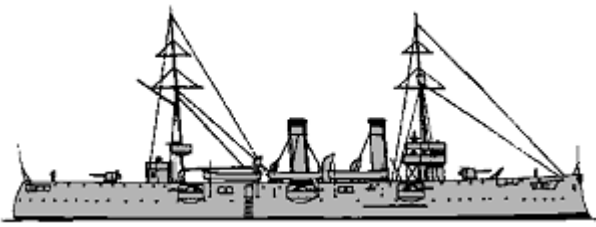
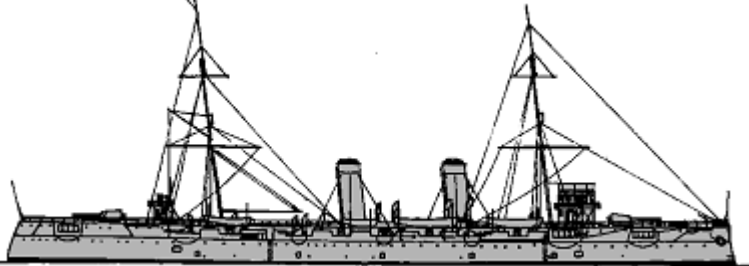
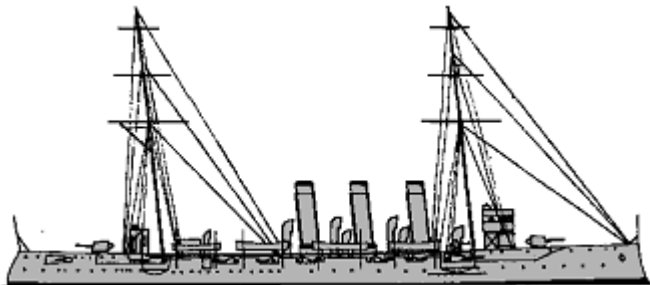

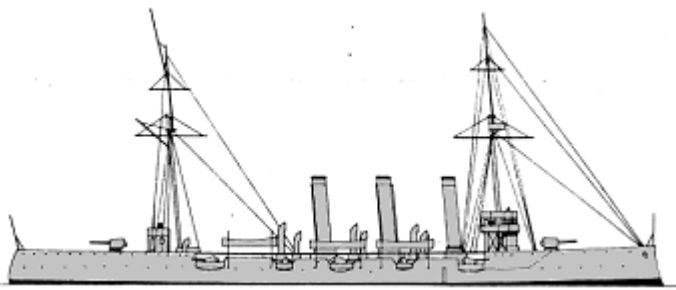
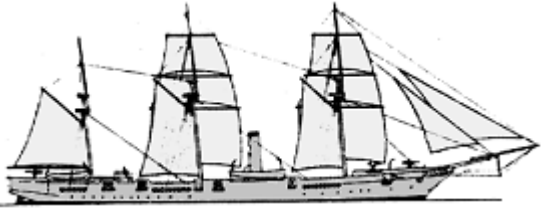

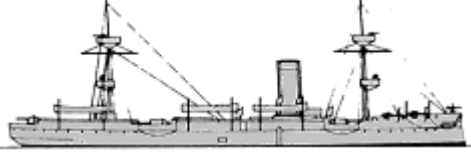
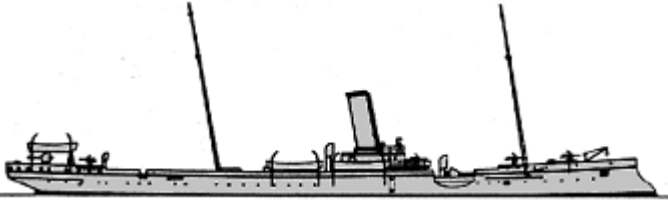
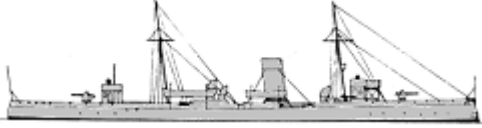
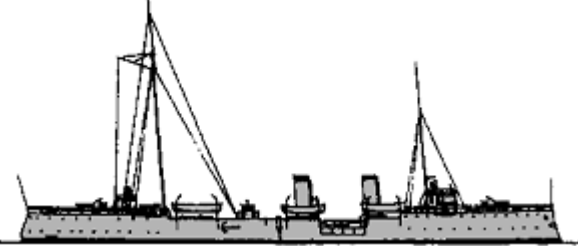
CL





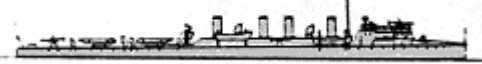



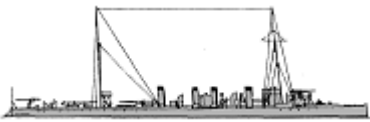

						
Akitsu	1	12	Akitsu	1894		3150t, 92.0x13.1x5.3m, 6b,2vte, 8400hp, 19kts, 314p; Harvey- 76deck, 114shields; 4x1-152/40, 6x1-120/40, 8x1-47/40, 4-350TT
Idzumi	1	13	Idzumi	1884		2920t, 82.3ppx12.8x5.6m, 12b,2hc, 6083hp, 18.2kts, 300p; compound- 25slopes, 13deck; 2x1-152/40, 6x1-120/40, 2x1-57/40, 6x1-47/40, 3-350TT
Suma	2	14	Suma	1896		2657(14)-2756(15)t, 95.0(14)-93.3(15)x12.2(14)-12.7(15)x4.6(14)-4.8(15)m, 8b,2vte(14)-9b,2vte(15), 8500hp, 20kts, 310p; Harvey- 51slopes, 25deck, 114shields; 2x1-152/40, 6x1-120/40, 10x1-47/40, 4x1-47/30, 2-380TT
		15	Akashi	1899		
Chitose	2	16	Chitose	1899		5598(16)-6066(17)t, 120.4(16)-121.5(17)x15.0(16)-14.9(17)x5.4m, 12b,2vte, 15000hp, 22.5kts, 434(16)-405(17)p; Harvey- 114slopes, 45deck, 114shields, 114CT; 2x1-203/45, 10x1-120/40, 12x1-76/40, 6x1-47/30, 5-350TT
		17	Kasagi	1898		
Tsushima	2	18	Niitaka	1904		3716t, 104.1x13.4x4.9m, 16b,2vte, 9500hp, 20kts, 320p; 64slopes, 38deck, 25shields, 102CT; 6x1-152/40, 10x1-76/40, 4x1-47/30
		19	Tsushima	1904		
Otowa	1	20	Otowa	1904		3000t, 103.9x12.6x4.8m, 10b,2vte, 10000hp, 21kts, 312p; Harvey- 76slopes, 76deck, 38shields, 102CT; 2x1-152/40, 6x1-120/40, 4x1-76/40, 2-450TT





							
CLL	Amagi	1	1	Amagi	1878		1030t, 65.3x10.1x4.4m, 2b,1hc, 720hp, 11.5kts, 301p; 1x1-173/22, 4x1-120/22, 1x1-120/17, 3x1-79/25, 3x4-25/60
	Tsukushi	1	2	Tsukushi	1880		1542t, 64.0ppx9.7x4.4m, 4b,2hc, 2887hp, 16.5kts, 186p; steel- 10deck, 25casemates, 13CT; 2x1-254/26, 4x1-120/32, 1x1-76/40, 2x1-47/40, 2-350TT
	Takao	1	3	Takao	1889		1927t, 71.1x10.4x4.0m, 5b,2hc, 2330hp, 15kts, 229p; 4x1-152/40, 2x1-47/40, 2-450TT
	Yaeyama	1	4	Yaeyama	1892		1609t, 96.9ppx10.5x4.0m, 8b,2hte, 5400hp, 20kts, 215p; steel- 13deck; 3x1-120/32, 10x1-47/40, 2-350TT
	Tatsuta	1	5	Tatsuta	1894		850t, 73.1ppx8.4x2.9m, 4b,2vte, 5500hp, 21kts, 100p; 2x1-120/40, 4x1-76/40, (1+2x2)-450TT
	Chihaya	1	6	Chihaya	1901		1464t, 87.7x9.6x2.8m, 4b,2vte, 6000hp, 21kts, 125p; 2x1-120/40, 4x1-76/40, 2x1-450TT
		1	America Maru	1898		5870brt, 128.9x15.6m, 2vte, 16.5kts	
		2	Bingo Maru	1897		6247brt, 135.6x15.1m, 2vte, 13kts	
		3	Hong Kong Maru	1896		6169brt, 135.6x15.1m, 2vte, 13kts	
		4	Kasuga	1897		3820brt, 114.3x13.5m, 1vte, 15kts	

AMC -	13		Maru			
		5	Kumano Maru	1901		5076brt, 122.0x14.8m, 1vte, 16kts
		6	Nikko Maru	1903		5539brt, 130.5x14.9m, 1vte, 17kts
		7	Nippon Maru	1898		6162brt, 131.4x15.5m, 2vte, 17kts
		8	Saikyo Maru	1888		2913brt, 99.1x12.6m, 1vte
		9	Shinano Maru	1900		6388brt, 135.7x15.1m, 2vte, 12.5kts
		10	Taichu Maru	1897		3320brt, 100.6x13.4m, 1vte, 12.5kts
		11	Tainan Maru	1897		3450brt, 100.6x13.1m, 1vte, 14.5kts
		12	Yawata Maru	1898		3818brt, 114.3x13.4m, 1vte, 15kts
		13	Kachidate Maru	1888		3457brt, 103.6x12.9m, 1vte



TORPEDO SHIPS

DD	Murakumo 6	1	Kagero	1899		361t, 65.7x6.0x1.7m, 3b,2vte, 5800hp, 30kts, 54p; 2x1-76/40, 4x1-57/40, 2x1-450TT
		2	Murakumo	1898		
		3	Shinonome	1899		
		4	Shiranui	1899		
		5	Usugumo	1900		
		6	Yugiri	1899		
	Ikazuchi 5	7	Ikazuchi	1899		410t, 68.5x6.3x1.6m, 4b,2vte, 6000hp, 31kts, 55p; 2x1-76/40, 4x1-57/40, 2x1-450TT
		8	Inazuma	1899		
		9	Akebono	1899		
		10	Oboro	1899		
		11	Sazanami	1899		
	Akatsuki 1	12	Kasumi	1902		415t, 68.5x6.3x1.7m, 4b,2vte, 6000hp, 31kts, 60p; 2x1-76/40, 4x1-57/40, 2x1-450TT
		13	Shirakumo	1902		
	Shirakumo 2	14	Asashio	1902		428t, 67.5x6.3x1.8m, 4b,2vte, 7000hp, 31kts, 59p; 2x1-76/40, 4x1-57/40, 2x1-450TT
		15	Asagiri	1903		
	Harusame 3	16	Harusame	1903		435t, 71.4x6.6x1.8m, 4b,2vte, 6000hp, 29kts, 55p; 2x1-76/40, 4x1-57/40, 2x1-450TT
		17	Murasame	1903		

	Akatsuki	1	18	Akatsuki	1902		305t, 61.0x5.7x2.4m, 8b,2vte, 3800hp, 27kts, 58p; 1x1-75/48, 3x1-47/40, 2x1-381TT
TB1	Kotaka	1	1	Kotaka	1888		203t, 50.3ppx5.8x1.7m, 2b,2vc, 1200hp, 17.8kts, 27p; steel- 25belt, 25deck; 2x4-25/60, (2+1x2)-350TT
	Fukuryu	1	2	Fukuryu	1886		128t, 43.9x5.0x2.3m, 1b,1vc, 1015hp, 20kts, 27p; 2x5-37/20, 2-350TT
	Shirataka	1	3	Shirataka	1900		126t, 46.5x5.1x1.3m, 2b,2vte, 2600hp, 28kts, 26p; 3x1-47/30, 3x1-350TT
	Hayabusa	15	4	Chidori	1901		150t, 46.4x4.9x1.5m, 2b,2vte, 4200hp, 29kts, 30p; 1x1-57/40, 2x1-47/30, (1+2x1)-450TT
			5	Hayabusa	1900		
			6	Kasasagi	1900		
			7	Manazuru	1900		
			8	Aotaka	1903		
			9	Uzura	1904		
			10	Hashitaka	1904		
			11	Hato	1903		
			12	Hibari	1904		
			13	Kamome	1904		
			14	Kari	1903		
	15	Kiji	1904				
	16	Otori	1904				
	17	Sagi	1904				
	18	Tsubame	1903				
TB2	22-go	1	1	25-go	1895		85t, 39.0ppx4.8x1.1m, 1b,1vte, 990hp, 19kts, 20p; 2x1-47/30, 3x1-350TT
	21-go	2	2, 3	21-go, 24-go	1894 - 1895		80t, 36.0ppx4.0x1.2m, 1b,1vte, 1150hp, 21kts, 21p; 1x1-47/30, 3x1-350TT
	29-go	2	4, 5	29-go, 30-go	1900		88t, 37.0ppx4.1x1.2m, 2b,1vte, 2000hp, 22.5kts, 20p; 1x1-47/40, (1+2x1)-350TT
	31-go	15	6 - 20	31-go-38-go, 44-go-47-go, 49-go, 60-go, 61-go	1900 - 1901		89t, 39.0ppx4.8x1.1m, 2b,1vte, 1200hp, 24kts, 20p; 2x1-47/30, (1+2x1)-350TT
	39-go	9	21	39-go	1901		102t, 46.5x4.7x1.6m, 2b,1vte, 1920hp, 26kts, 20p; 2x1-47/40, 3x1-350TT
			22	40-go	1901		
			23	41-go	1901		
			24	43-go	1901		
			25	62-go	1902		
26	63-go	1902					
27	64-go	1902					

		28	65-go	1902		
		29	66-go	1902		
	67-go	9	30 - 38	67-go-75-go	1903 - 1904	 89t, 40.1x4.9x1.3m, 2b,1vte, 1200hp, 23.5kts, 24p; 2x1-47/40, (1+2x1)-350TT
TB3	5-go	14	1 - 14	5-go-14-go, 16-go-19-go	1892 - 1894	 54t, 35.0x3.4x0.9m, 1b,1hc, 525hp, 20kts, 16p; 1x1-47/30, (1+1x1)-350TT
	15-go	1	15	20-go	1894	 54t, 35.0x3.5x1.0m, 1b,1vte, 657hp, 20kts, 20p; 1x1-47/30, 1x2-350TT
	26-go	2	16, 17	26-go, 27-go	1887	No picture 74t, 33.7x3.5x1.1m, 1b,1hc, 338(16)-442(17)hp, 13.8(16)-15.5(17)kts, 28p; 2x5-37/20, 2-350TT
	50-go	7	18 - 24	50-go, 52-go, 54-go-58-go	1900 - 1902	 54t, 34.0x3.5x1.0m, 1b,1vte, 660hp, 20kts, 16p; 1x1-47/40, 1x2-350TT

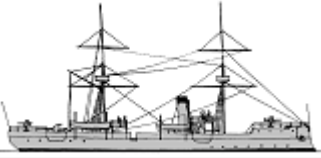
OTHER FIGHTING SHIPS

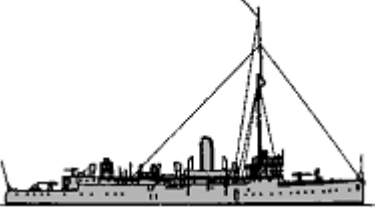
PG	Banjo	1	1	Banjo	1880	No picture	708t, 46.9x7.9x3.9m, 4b,1hc, 659hp, 10kts, 112p; 1x1-149/22, 1x1-120/22, 2x1-79/25, 3x4-25/60
	Maya	3	2	Maya	1888		622t, 46.8ppx8.2x3.1m, 2b,2hcda, 963hp, 12kts, 104p; 1x1-209/19(3), 4x1-120/40(2,4), 1x1-120/22(3), 2x1-57/43(2), 2x1-47/40(2), 4x1-47/40(4), 2x4-25/60
			3	Chokai	1888		
			4	Akagi	1890		
	Chinto	4	5	Chinto	1879		490t, 38.1ppx8.8x2.9m, 2b,2hc, 450hp, 10kts, 28p; 1x1-279/23, 2x1-76/19, 2x10-11.4/94
			6	Chinsei	1879		
			7	Chinnan	1879		
			8	Chimpen	1879		
	Chinchu	2	9	Chinchu	1881		500t, 38.1ppx8.8x2.9m, 2b,2hc, 450hp, 10kts, 28p; 1x1-279/23, 2x1-102/25, 2x10-11.4/94
			10	Chimpen	1881		
Uji	1	11	Uji	1903		620t, 57.8x8.4x2.1m, 2b,2vte, 1000hp, 13kts, 86p; 4x1-76/40	
APG -	8	1	Asahi Maru	1884		497brt	
		2	Hijikawa Maru 5-go	1897		564brt	
		3	Kagawa Maru	1903		613brt	
		4	Manda Maru	1900		248brt	
		5	Miyoshima Maru	1902		273brt	
		6	Mukogawa Maru	1893		418brt	
		7	Ryojun Maru	1897		499brt	

		8	Yoshidagawa Maru	1890		310brt
--	--	---	------------------	------	--	--------

MINE WARFARE SHIPS

AML	-	3	1	Taihoku Maru	1890	2487brt, 91.6x12.5m, 1vte, 10kts
			2	Koryo Maru	1903	745brt
			3	Uwajima Maru	1901	444brt





[home](#)[World navies yesterday](#)[1905](#)

Mexico 01 January 1905

CRUISERS

CL	Porfirio Díaz	1	1	Porfirio Díaz	1892		1200t, 68.0x9.3x4.3m, 2b,1vte, 1300hp, 15kts, 270p; 4x1-120/40, 2x1-57/40
----	---------------	---	---	---------------	------	--	---

OTHER FIGHTING SHIPS

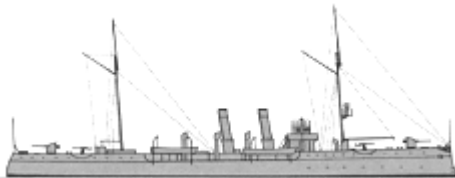
PG	Independencia	1	Independencia	1874		480t, 38.1x7.3x2.7m, 1hc, 425hp, 10kts, 63p; 1x1-163/16, 4x1-95/21
		2	Libertad	1874		
	Democrata	3	Democrata	1875		445t, 42.7x7.6x3.4m, 600hp, 11kts, 80p; 2x1-163/16, 2x1-107/19
		4	Mexico	1875		
	Tampico	5	Tampico	1902		980t, 61.0ppx10.1x3.4m, 2vte, 2400hp, 16kts, 98p; 2x1-102/40, 6x1-57/40, 1-356TT, 200troops
		6	Vera Cruz	1902		
	Nicholas Bravo	7	Nicholas Bravo	1904		1493t, 73.8x10.4x3.0m, 2vte, 2565hp, 17kts, 116p; 2x1-102/40, 6x1-57/40, 1-356TT
		8	Morales	1904		

[home](#)

[World navies yesterday](#)

[1905](#)

Morocco 01 January 1905

OTHER FIGHTING SHIPS





PG	Es Sid El Turki	1	1	Es Sid El Turki	1894	No picture	460brt, 1200hp, 14.5kts; 2x1-76/18
----	-----------------	---	---	-----------------	------	------------	------------------------------------

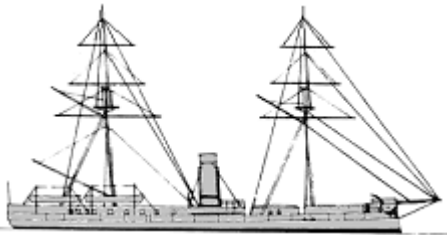

© Ivan Gogin, 2015

[home](#)[World navies yesterday](#)[1905](#)

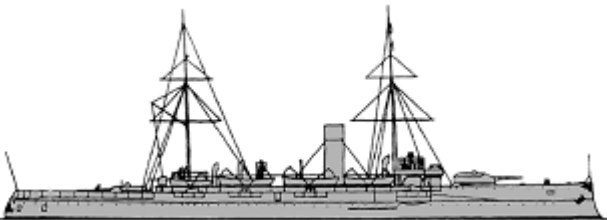
Netherlands 01 January 1905

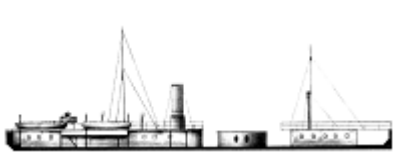
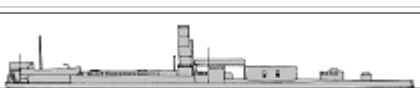
BATTLESHIPS



BC	Schorpionen	1	Schorpionen	1868		2140(1)-2078(2)t, 62.5x11.9x4.8(1)-5.1(2)m, 4b,2hrccr, 2225(1)-2260(2)hp, 13(1)-12.5(2)kts, 136p; iron-152side, 25deck, 278turret, 144CT; 1x1-283/20, 5x1-37/20, 2x5-37/17
		2	Stier	1868		
	Evertsen	3	Evertsen	1896		3464t, 86.2x14.3x5.2m, 6b,2vte, 4700hp, 16kts, 263p; steel- 150belt, 55deck, 240barbette, 240CT; (1x2+1x1)-209/32, 2x1-149/32, 6x1-75/27, 8x1-37/20, 3-450TT
		4	Piet Hein	1896		
		5	Kortenaer	1895		
Koningin Regentes	6	Koningin Regentes	1901		5002(6,7)-5084(8)t, 96.6x15.2x5.8m, 6b,2vte, 6500hp, 16.5kts, 340p; 150belt, 50deck, 100turrets, 250CT; 2x1-238/37, 4x1-149/37, 8x1-75/37, 4x1-37/20, 3-450TT	
	7	De Ruyter	1902			
	8	Hertog Hendrik	1904			
MON	Heiligerlee	1	Heiligerlee	1868		1520t, 57.0x13.5x3.1m, 4b,2hrccr, 630hp, 9kts, 117p; iron- 140side, 25deck, 285turret, 140CT; 1x1-283/20, 2x1-37/20, 2x5-37/17
	Bloedhond	2	Bloedhond	1870		1656(2)-1559(3)t, 55.7(2)-56.5(3)x14.2(2)-13.4(3)x3.2(2)-3.0(3)m, 4b,2hrccr, 680(2)-534(3)hp, 7.7(2)-7(3)kts, 117p; iron- 140side, 25deck, 285turret, 140CT; 1x1-283/20, 2x1-37/20, 2x5-37/17
		3	Cerberus	1870		
	Adder	4	Haai	1872		1555(4,5,7,8)-1585(6)t, 58.6-59.6x13.4x3.0m, 4b,2hc, 560-740hp, 7-8kts, 117p; iron- 140side, 25deck, 285turrets, 140CT; 1x1-283/20, 2x1-37/20, 2x5-37/17
		5	Hyena	1871		
		6	Luipaard	1878		
		7	Panther	1871		
		8	Wesp	1872		
	Draak	1	9	Draak	1878	



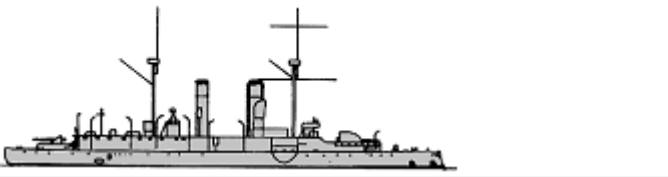
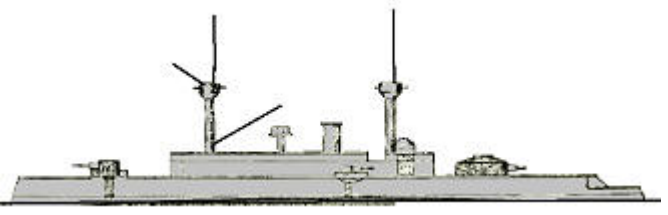
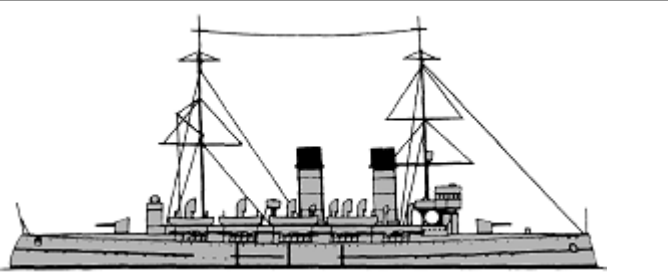
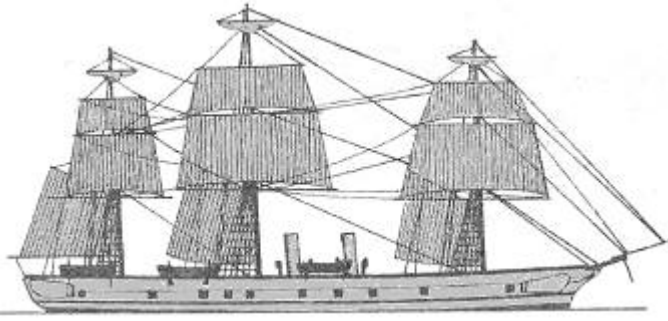



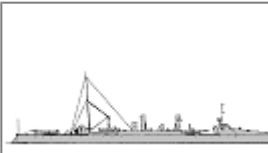
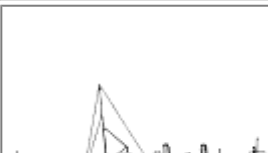

	Matador	1	10	Matador	1879		1968t, 63.9x14.5x3.2m, 4b,2hc, 690hp, 7.5kts, 131p; iron- 140side, 25deck, 305turret, 140CT; 1x2-283/20, 2x1-37/20, 2x5-37/17
	Reinier Claeszen	1	11	Reinier Claeszen	1894		2440t, 70.0x13.5x4.6m, 3b,2vc, 2315hp, 12.5kts, 161p; compound- 120belt, 75deck, 280turret, 280CT; 1x1-209/32, 1x1-173/32, 4x1-50/37, 2-356TT

CRUISERS

	Sumatra	1	1	Sumatra	1891		1693t, 70.0x11.3x4.7m, 4b,2vte, 2350hp, 17kts, 181p; steel- 38deck, 100shields, 150CT; 1x1-209/32, 1x1-149/32, 2x1-120/32, 4x1-37/20, 2x5-37/17, 2-356TT
CL	Koningin Wilhelmina der Nederlanden	1	2	Koningin Wilhelmina der Nederlanden	1894		4530t, 99.8x14.9x6.1m, 6b,2vte, 4600hp, 15.8kts, 296p; compound- 75slopes, 50deck, 280turret; 1x1-283/27, 1x1-209/32, 2x1-173/32, 4x1-75/37, 6x1-37/20, 4x5-37/17, 4-356TT
	Holland	6	3	Holland	1898		3840(3-5)-3970(6-8)t, 93.3(3-5)-94.7(6-8)x14.8x5.4m, 8b,2vte(3-5)-10b,2vte(6-8), 10000hp, 20kts, 371p; Harvey- 57deck, 152shields, 102CT; 2x1-149/37, 6x1-120/37, 6x1-75/37, 8x1-37/20, 4x5-37/17, 2-450TT
	4		Zeeland	1898			
	5		Friesland	1898			
	6		Gelderland	1900			
	7		Noord Brabant	1900			
	8	Utrecht	1900				
CLL	Atjeh	1	1	Atjeh	1877		3669t, 92.1x12.5x7.0m, 3300hp, 14.8kts, 306p; 6x1-173/22, 8x1-120/16, 8x1-37/20, 6x5-37/17
	Sommelsdijk	1	2	Sommelsdijk	1882	No picture	997t, 54.5x9.5x3.6m, 759hp, 11.4kts, 96p; 1x1-149/22, 3x1-120/16, 2x1-37/20, 2x5-37/17
	Java	1	3	Java	1885	No picture	1280t, 62.6x9.5x3.7m, 1017hp, 12.6kts, 104p; 1x1-149/22, 3x1-120/16, 2x1-37/20

TORPEDO SHIPS

	Ardjoeno	10	1-10	Ardjoeno, Dempo, Habang, Krakatau, Cycloop, Batok, Foka, Idjen, Empong, Goentoer	1887-1892		79-90t, 38.4-39.2x4.0x1.8-2.1m, 1b,1vc, 725-1089hp, 19.1-22.8kts, 16p; 2x1-37/20, 2-450TT
	No.XXIII	1	11	Cerberus	1888		82t, 38.2x4.0x1.8m, 1b,1vc, 912hp, 21.2kts, 16p; 2x1-37/20, (1+2x1)-450TT
			12-				



TB1cl	Lamongan	3	14	Lamongan, Nobo, Makjan	1891	No picture	59t, 32.9x4.0x1.6m, 1b,1vc, 780hp, 20.4kts, 15p; 2x1-37/20, 2-450TT	
	Hydra	5	15	Hydra	1900		103t, 39.6x4.1x2.1m, 2b,1vte, 1500hp, 24kts, 21p; 2x1-37/20, 3x1-450TT	
			16	Scylla	1900			
			17	Minotaurus	1902			
			18	Python	1902			
			19	Sphinx	1903			
	Ophir	6	20	Ophir	1901		140t, 46.6x4.7x2.4m, 2b,1vte, 2000hp, 25kts, 25p; 2x1-50/37, 3x1-450TT	
			21	Pangrango	1901			
			22	Rindjani	1901			
			23	Smeroe	1903			
			24	Tangka	1903			
			25	Wajang	1903			
	TB2cl	No.IV	1	1	No.IV	1879		29t, 23.2x3.2x1.6m, 1b,1hda, 250hp, 18kts, 11p; 2spar torpedoes
		No.V	3	2-4	No.V, VIII, IX	1879		29t, 24.6x3.2x1.6m, 1b,1hda, 250hp, 18kts, 11p; 2spar torpedoes
No.X		3	5-7	No.X, XI, XII Argus	1879		29t, 24.6x3.2x1.6m, 1b,1hda, 250hp, 18kts, 11p; 2spar torpedoes	
No.XIII		5	8-12	No.XIII, XIV, XVI-XVIII	1879-1881		30t, 24.6x3.2x1.6m, 1b,1hda, 250hp, 17-18kts, 11p; 1x1-37/20(10), 2-356TT(10), 2spar torpedoes(8,9,11,12)	
No.XIX		2	13, 14	No.XIX, XX	1881		30t, 24.6x3.2x1.6m, 1b,1hda, 250hp, 18kts, 11p; 2spar torpedoes	
No.XXI		2	15, 16	Hekla, Etna	1882		45t, 31.0x3.8x1.7m, 1b,1hc, 550hp, 21.4kts, 15p; 2x1-37/20, 2-356TT	
No.III		3	17-19	No.III Jan Haring, No.XXI Jasper Leynssen, No.XXII Jacob Hobein	1891		37t, 25.6x3.2x1.6m, 1b,1vc, 440hp, 17.5kts; 2x1-37/20, 2-356TT	

ESCORTS

AFPV	-	2	1	Dolfijn	1889		
			2	Zeehond	1892		

OTHER FIGHTING SHIPS

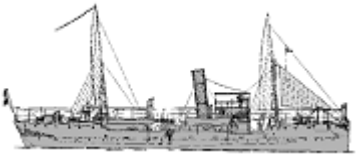
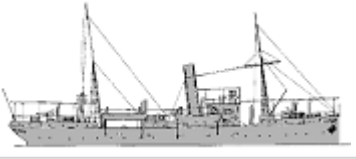
Aruba	1	1	Aruba	1873	No picture	786t, 50.0x9.0x3.8m, 413hp, 9.5kts; 1x1-149/22, 2x1-120/16, 1x1-75/5, 2x1-37/20
Batavia	1	2	Bali	1878	No picture	853t, 53.6x9.0x3.7m, 400-500hp, 8.4-9.3kts, 84-104p; 1x1-149/22, 3x1-120/16, 2x1-37/20
Suriname	1	3	Suriname	1877	No picture	884t, 54.0x9.0x3.6m, 450hp, 9.5kts, 90p; 1x1-149/22, 3x1-120/16, 2x1-37/20
Ceram	2	4	Ceram	1887	No picture	541t, 52.8x7.8x3.1m, 800hp, 12.8kts, 83p; 3x1-120/16, 2x1-37/20
		5	Flores	1887		
Lombok	2	6	Lombok	1891	No picture	600t, 52.4x8.3x3.4m, 960hp, 12.3kts, 87p; 3x1-120/16, 2x1-37/20
		7	Sumbawa	1891		
Borneo	1	8	Borneo	1892	No picture	800t, 53.8x9.5x4.1m, 1040hp, 13.2kts, 102p; 6x1-105/32, 2x1-37/20, 2x5-37/17
Nias	4	9	Nias	1895		810-820t, 53.9x9.4x3.7m, 2vte, 1300hp, 12.9kts, 97p; 2x1-105/32, 4x1-37/20, 2x5-37/17
		10	Mataram	1896		
		11	Edi	1897		

PG	Koetei	3	12	Serdang	1897		
			13	Koetei	1898		788t, 53.7x9.4x3.7m, 2vte, 1380hp, 13.7kts, 97p; 2x1-105/32, 4x1-37/20, 2x5-37/17
			14	Siboga	1898		
	15	Assahan	1900				
	Hydra	8	16	Hydra	1873		221t, 25.9x8.0x2.2m, 2b,1vc, 124-146hp, 7.5-8kts, 34p; 1x1-209/32, 2x1-37/20, 1x5-37/20
			17	Ever	1873		
			18	Das	1876		
			19	Geep	1875		
			20	Gier	1875		
			21	Havik	1874		
			22	Lynx	1875		
			23	Sperwer	1875		
	Wodan	15	24	Wodan	1877		264-280t, 27.8x8.2x2.3m, 2b,1vc, 101-171hp, 7-8.3kts, 34p; 1x1-283/27(32,35-38), 1x1-283/20(24-31,33,34), 2x1-37/20, 1x5-37/17
			25	Balder	1879		
			26	Braga	1879		
27			Freyr	1877			
28			Heimdall	1879			
29			Njord	1878			
30			Thor	1877			
31			Tyr	1878			
32			Hefring	1880			
33			Vali	1879			
34			Vidar	1879			
35			Bulgia	1884			
36			Dufa	1879			
37			Hadda	1880			
38			Udur	1879			
PR	Vahalis	1	1	Vahalis	1870	No picture	365t, 38.4x8.5x1.6m, 240hp, 7.5kts, 34p; iron- 100side, 13deck, 25turrets; 2x1-47/40
	Isala	4	2	Isala	1876	No picture	373-388t, 48.6x7.6x1.4m, 306-400hp, 7.7-8kts, 44p; iron- 125side, 25deck, 125turrets; 2x1-120/16
			3	Rhenus	1877		
			4	Mosa	1878		
			5	Merva	1879		





© Ivan Gogin, 2014

[home](#)[World navies yesterday](#)[1905](#)

Norway 01 January 1905

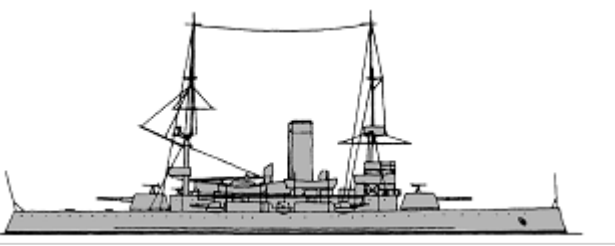
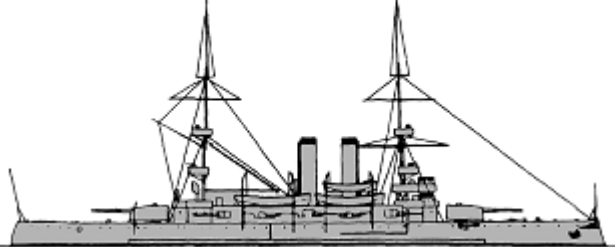
BATTLESHIPS

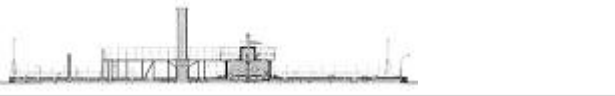





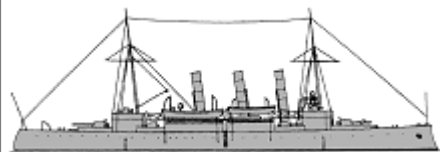





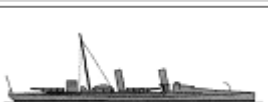

BC	Harald Haarfagre	1	Harald Haarfagre	1898		3858t, 92.7x14.8x5.4m, 3b,2vte, 4000hp, 16.9kts, 245p; Harvey- 178belt, 51deck, 203turrets, 152CT; 2x1-209/44, 6x1-120/44, 6x1-76/40, 6x1-37/45, 2-450TT
		2	Tordenskjold	1898		
Norge	Norge	3	Norge	1901		4166t, 94.6x15.4x5.4m, 6b,2vte, 4500hp, 16.5kts, 266p; 152belt, 51deck, 203turrets, 152CT; 2x1-209/44, 6x1-149/46, 8x1-76/40, 4x1-47/46, 2-450TT
		4	Eidsvold	1901		
MON	Skorpionen	1	Skorpionen	1867		1470t, 61.0x13.9x3.4m, 4b,1vle, 330hp, 6kts, 84p; iron- 125side, 25deck, 305turret; 1x2-120/44, 2x1-65/50, 2x1-37/40
	Mjølnær	2	Mjølnær	1868		1539t, 62.3x13.9x3.5m, 4b,1vle, 450hp, 8kts, 84p; iron- 125side, 25deck, 305turret; 1x2-120/44, 2x1-65/50, 2x1-37/40
		3	Thrudvang	1869		
Thor	1	4	Thor	1876		2035t, 62.3x14.5x3.8m, 4b,1vle, 600hp, 8kts, 94p; iron- 175side, 25deck, 365turret; 1x2-120/44, 2x1-65/50, 2x1-37/40

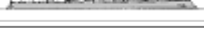
CRUISERS

CL	Viking	1	1	Viking	1891		1181t, 63.5x9.3x3.7m, 4b,2vc, 2000hp, 15kts, 125p; Harvey- 35deck, 25shields, 35CT; 1x1-149/46, 1x1-120/44, 4x1-76/40, 2x1-75/37, 6x1-47/40, 1-356TT
	Frithjof	1	2	Frithjof	1896		
							1427t, 68.2x10.0x4.0m, 6b,2vte, 2800hp, 15kts, 154p; Harvey- 30deck; 2x1-120/44, 4x1-76/40, 4x1-37/45, 1-450TT



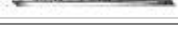



TORPEDO SHIPS

DD	Valkirjen	1	1	Valkirjen	1896		415t, 59.4x7.4x2.6m, 2b,2vte, 3300hp, 23kts, 59p; 2x1-76/40, 4x1-37/45, 2x1-450TT
TB1cl	Hval	3	1	Hval	1896		102t, 39.9x4.8x2.2m, 2b,1vte, 1100hp, 21kts, 23p; 2x1-37/45, 2x1-450TT
			2	Delfin	1896		
			3	Hai	1896		
	Storm	3	4	Storm	1898		107t, 39.9x4.8x2.2m, 2b,1vte, 1100hp, 21kts, 23p; 2x1-37/45, 2x1-450TT
			5	Brand	1898		
			6	Trods	1898		
	Laks	4	7	Laks	1900		107t, 38.5x4.8x2.2m, 2b,1vte, 1150hp, 21kts, 23p; 2x1-37/45, 2x1-450TT
			8	Sild	1900		
			9	Sæl	1901		
			10	Skrei	1901		
TB2cl	Rap	1	1	Rap	1873		15t, 17.3x2.3x0.9m, 1b,1hda, 90hp, 15kts, 6p
	Ulven	1	2	Ulven	1878		16t, 17.2x2.9x1.1m, 1b,1hda, 70hp, 10kts, 6p
	Od	1	3	Od	1882		41t, 29.0xxm, 1b,1vc, 420hp, 18kts; 1x1-37/20, 1-356TT
	Springer	1	4	Springer	1883		44t, 30.0xxm, 1b,1vc, 420hp, 18kts; 1x1-37/20, 2-356TT
	Rask	2	5, 6	Rask, Pil	1885-1886		44t, 30.5xxm, 1b,1vc, 500hp, 19kts; 1x1-37/20, 2-356TT
	Snar	1	7	Snar	1887		49t, 32.0xxm, 2b,1vc, 600hp, 19kts; 1x1-37/20, 2-356TT
	Orm	2	8, 9	Orm, Oter	1888		54t, 33.0xxm, 2b,1vc, 600hp, 19kts; 1x1-37/20, 2-381TT
	Varg	2	10, 11	Varg, Raket	1894		64t, 34.5x3.8x1.6m, 2b,1vte, 650hp, 19kts, 12p; 1x5-37/12, 2-450TT
	Lyn	3	12-14	Lyn, Blink, Glimt	1896-1897		64t, 34.5x3.8x1.8m, 2b,1vte, 650hp, 19kts, 21p; 1x1-37/45, (1+1x1)-450TT
	Djerv	3	15-17	Djerv, Kvikk, Dristig	1897-1898		66t, 34.5x3.8x1.7m, 2b,1vte, 650hp, 19kts, 21p; 2x1-37/45, (1+1x1)-450TT
	Myg	1	18	Myg	1900		27t, 25.0xxm, 1b,1vc, 285hp, 17.7kts; 1x1-37/45, 1-356TT
	Hvass	2	19, 20	Hvass, Kjæk	1901		74t, 34.1x4.4x1.6m, 2b,2vte, 650hp, 19kts, 16p; 2x1-37/45, (1+1x1)-450TT
	Hauk	2	21, 22	Hauk, Falk	1904		73t, 34.9x4.4x1.6m, 2b,2vte, 750hp, 20kts, 16p; 2x1-37/45, (1+1x1)-450TT

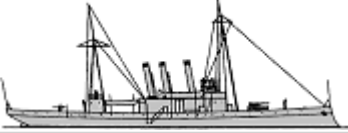
OTHER FIGHTING SHIPS

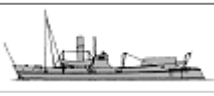
	Sarpen	1	1	Sarpen	1861	No picture	220t; 2x1-65/50, 2x1-37/45
	Trold	1	2	Trold	1872	No picture	97t, 65hp, 7.5kts; 1x1-155/17

PG	Dverg	7	8-9	Dverg, Kongsberg, Skudesnes, Skien, Tønsberg, Langesund, Porsgrund	1872-1883	No picture	55t, 70hp, 7.5kts; 1x1-155/17
	Vale	2	10	Vale	1874		229t, 27.3x7.9x2.2m, 2b,2vc, 200hp, 8kts, 38p; 1x1-267/14, 1x1-37/20, 2x5-37/17
			11	Uller	1877		
	Sleipner	1	12	Sleipner	1878		720t, 53.3x7.9x3.4m, 2vc, 650hp, 12kts, 90p; 1x1-149/37, 2x1-76/40, 2x1-65/50, 2x5-37/17
	Brage	2	13	Brage	1879		264t, 28.9x7.9x2.2m, 2b,2vc, 220hp, 8.5kts, 38p; 1x1-267/14, 1x1-37/20, 2x5-37/17, 1-356TT(14)
			14	Nor	1879		
	Vidar	1	15	Vidar	1882		262t, 28.9x7.9x2.2m, 2b,2vc, 330hp, 9.5kts, 38p; 1x1-267/17, 1x1-37/20, 2x5-37/17
	Ellida	1	16	Ellida	1882	No picture	1045t, 58.0x9.9x4.4m, 2vc, 900hp, 10.5kts, 130p; 2x1-76/40, 1x1-75/52, 2x1-65/50, 2x1-37/45
	Gor	2	17	Gor	1885		290(17)-278(18)t, 31.3x8.5x2.2m, 2b,2vc, 420hp, 10.5kts, 44p; 1x1-263/17, 1x1-57/40(18), 1x1-37/20(17), 2x5-37/17, 1-356TT
18			Tyr	1887			
Æger	1	19	Æger	1894		413t, 33.2x8.8x2.4m, 2b,2vte, 350hp, 9kts, 43p; 38deck; 1x1-209/35, 1x1-65/50, 2x1-47/40	

FISHERY PROTECTION VESSELS

FPV	Heimdal	1	1	Heimdal	1892	No picture	640t; 4x1-76/40
	Michael Sars	1	2	Michael Sars	1900	No picture	226t

[home](#)[World navies yesterday](#)[1905](#)

Ottoman Empire 01 January 1905

BATTLESHIPS

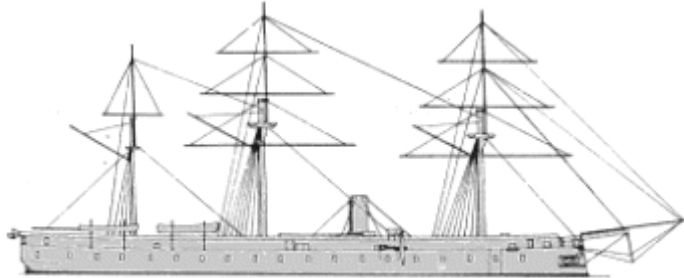
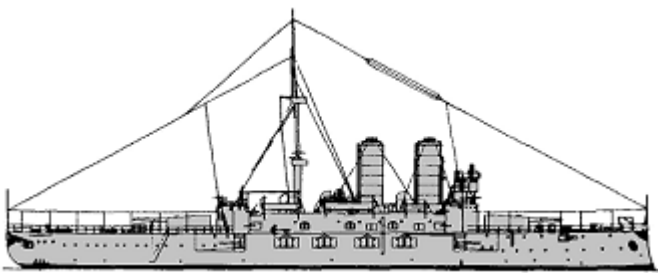
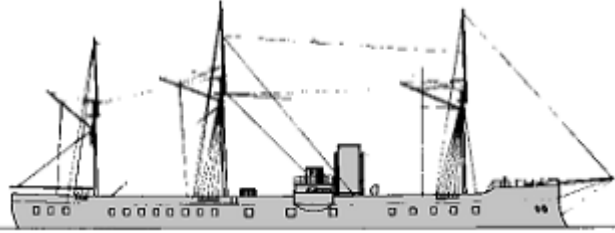
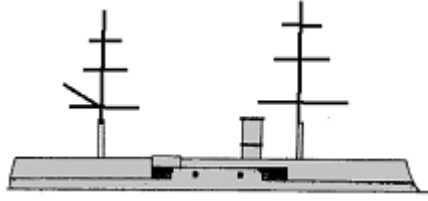
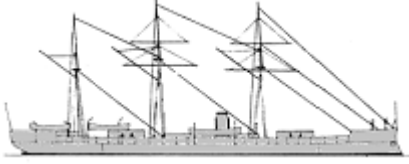
BB	Osmaniye	1	Osmaniye	1865		6400t, 91.4x17.0x7.9m, 6b,vte, 3735hp, 10kts, 361p; iron- 140belt, 127battery; 2x1-235/32, 8x1-149/22, 5x1-105/32, 2x1-47/40, 7x4-25/42
		2	Orhaniye	1866		
		3	Mahmudiye	1866		
	Mesudiye	1	4 Mesudiye	1875		9710t, 102.4x17.9x7.9m, 16b,2vte, 11135hp, 17kts, 700p; iron- 305belt, 229turrets, 203CT; 2x1-234/47, 12x1-152/45, 14x1-76/50, 10x1-57/40, 2x1-47/40
	Asar-i Tevfik	1	1 Asar-i Tevfik	1870		4687t, 83.0ppx16.0x6.5m, 6b,1hc, 3560hp, 13kts, 320p; iron- 203belt, 152battery; 6x1-229/14, 2x1-209/32, 2x1-87/22, 2x1-57/37, 2x1-25/42
	Asar-i Şevket	1	2 Necm-i Şevket	1870		2047t, 66.4x13.0x5.0m, 4b,1hc, 1900hp, 12kts, 170p; iron- 152belt, 114battery; 1x1-229/14, 4x1-178/16, 2x1-87/22, 2x1-57/37, 2x5-37/27, 1x1-25/42, 1x1-356TT(3)
	Hifz-ur Rahman	1	3 Hifz-ur Rahman	1870		2540t, 64.4x13.6x4.4m, 2b,2hc, 2000hp, 12kts, 122p; iron- 140belt, 38deck, 140turrets; 1x2-203/15, 1x1-149/22, 1x1-120/22, 4x1-37/37, 2x4-25/42

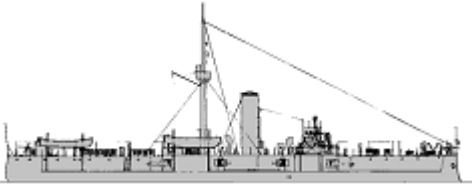
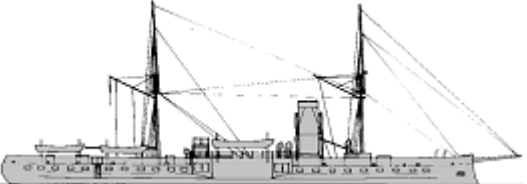
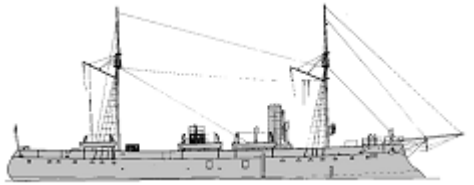
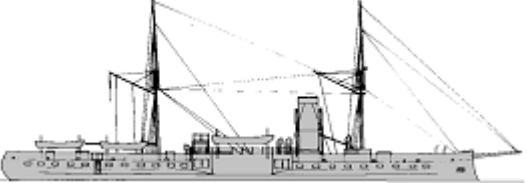

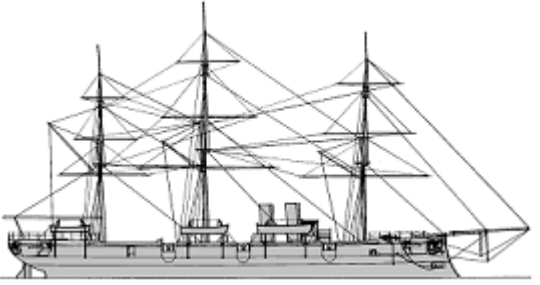
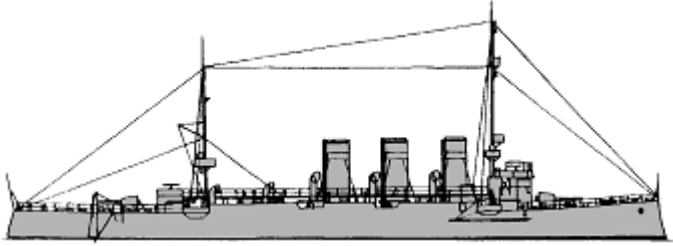
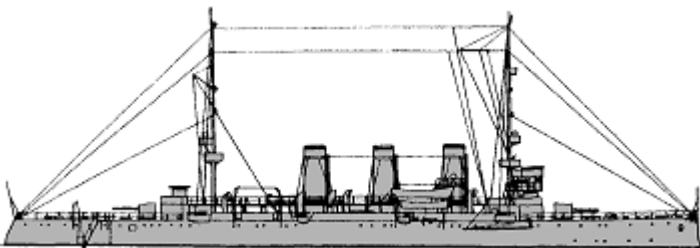

BC	Avnillah	2	4	Avnillah	1870		2362t, 71.9x11.0x5.0m, 4b,1hc, 2200hp, 12kts, 145p; iron- 152belt, 127casemates; 4x1-203/15, 2x1-87/22
	Feth-i Bülend	1	6	Feth-i Bülend	1870		2762t, 72.0ppx12.0x5.5m, 6b,1hc, 3250hp, 13kts, 169p; iron- 229belt, 229casemates; 4x1-229/14, 2x1-87/22, 2x1-57/37, 2x5-37/27, 1x1-25/42
	İclaliye	1	7	İclaliye	1871		2228t, 66.0x13.0x5.3m, 2b,1hc, 1800hp, 12kts, 148p; iron- 152belt, 114battery; 2x1-229/14, 2x1-178/16, 1x1-149/32, 2x1-87/22, 2x1-57/37, 2x5-37/27, 2x1-25/42
	Mukaddeme-i Hayir	1	8	Mukaddeme-i Hayir	1874		2762t, 72.0ppx12.0x5.5m, 4b,1hc, 3000hp, 12kts, 169p; iron- 229belt, 229casemates; 4x1-229/14, 2x1-87/22, 2x1-57/37, 2x5-37/27, 2x1-25/42

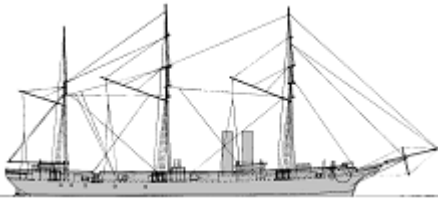
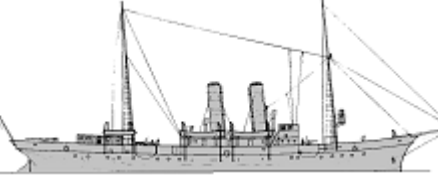
CRUISERS

CL	Heybetnüma	1	1	Heybetnüma	1895		1958t, 68.9ppx11.3x5.2m, 6b,1hte, 2786hp, 12kts, 190p; 2x1-149/22, 2x1-120/22, 4x1-47/37
	Mecidiye	1	2	Mecidiye	1903		3967t, 102.4x12.8x4.8m, 16b,2vte, 12500hp, 22kts, 312p; 102slopes, 38deck; 2x1-152/44, 8x1-120/45, 6x1-47/50, 6x1-37/30, 2-450TT
	Hamidiye	1	3	Hamidiye	1904		3904t, 112.0x14.5x4.9m, 6b,2vte, 12000hp, 22kts, 302p; 102slopes, 38deck; 2x1-152/45, 8x1-120/45, 6x1-47/50, 6x1-37/30, 2x1-450TT

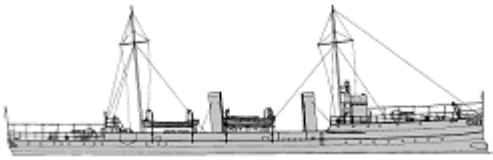

CLL	Beyrut	1	Beyrut	1860		599t, 52.9ppx8.1x3.9m, 2b,1hse, 450hp, 10kts, 120p; 2x1-120/22, 2x1-37/42(2,3), 2x1-37/20(1), 2x1-25/42(1)	
		2	İskenderiye	1863			
		3	Meriç	1864			
	Mansure	2	4	Mansure	1864	No picture	783bm, 55.1x9.3x4.4m, 2b,1hse, 650hp, 10kts, 130p; 2x1-149/22, 2x1-120/22, 3x1-37/20, 2x1-25/42
			5	Muzaffer	1864		
	Zuhaf	2	6	Zuhaf	1896		643t, 57.9ppx7.3x3.5m, 2b,1vte, 640hp, 14kts, 82p; 1x1-120/22, 4x1-37/37
			7	Kilid Bahir	1896		
	Lütf-ü Hümayun	1	9	Lütf-ü Hümayun	1896	No picture	1313t, 64.0ppx9.1x4.0m, 2b,1hc, 2160hp, 12kts; 2x1-149/37, 2x1-120/37, 4x1-37/37, 2-450TT

TORPEDO SHIPS

PGT	Peleng-i Derya	1	1	Peleng-i Derya	1896		900t, 75.5x8.5x2.9m, 4b,2vte, 4700hp, 18kts, 80p; 2x1-105/32, 6x1-47/37, 5x5-37/27, (1+2x1)-356TT
TB	Gilyum	3	1-3	Tir-i Zafer, Seyf-i Bahri, Vesile-i Nusret	1886		85t, 37.7x4.8x2.0m, 1b,1vte, 980hp, 21kts, 18p; 2x5-37/27, 2-356TT
	Nasir	5	4-8	Nasir, Fatih, Nusret, Tarik, Pervin	1889-1890		87t, 39.0x4.8x2.6m, 1b,1vte, 1200hp, 21kts, 27p; 2x5-37/27, 2-356TT
	Ejder	1	9	Ejder	1893	No picture	150t, 49.2x5.7x2.2m, 2b,2vte, 2200hp, 24kts, 22p; 5x5-37/27, (1+1x1)-356TT
	Berk Efşan	2	10	Berk Efşan	1894	No picture	230t, 59.9x6.6x2.4m, 2b,2vte, 3500hp, 21kts, 50p; 6x5-37/27, 2-428TT
			11	Tayyar	1894		
	Hamidiye	2	12	Hamidiye	1902		145t, 50.6x5.6x1.2m, 3b,2vte, 2400hp, 26kts, 30p; 1x1-37/20, 2x1-450TT
			13	Abdül Mecid	1902		
Akhisar	2	14	Akhisar	1904		165t, 51.0x5.7x1.4m, 2b,2vte, 2400hp, 24kts, 30p; 2x1-37/20, 2x1-450TT	
		15	Alpagot	1904			

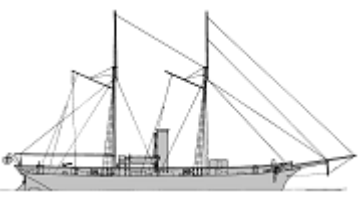
OTHER FIGHTING SHIPS

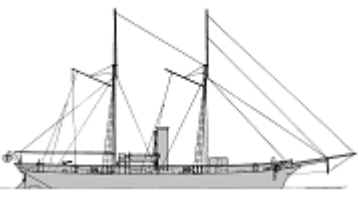
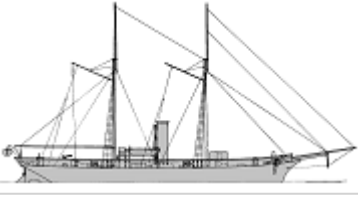
	Akka	1	1	Şevket Nüma	1860		120t, 35.4x6.0x2.7m, 1b,1vte, 400hp, 10kts, 45p; 4x1-75/37, 1x1-37/37
--	------	---	---	-------------	------	--	---

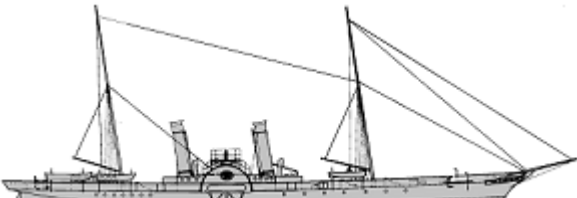
PG	Musul	1	2	Musul	1866		125t, 39.9ppx6.4x2.8m, 1b,1hsa, 9kts, 35p; 2x1-57/27, 2x5-37/17
	İntibah	2	3	Müjderesan	1866		163t, 40.4ppx6.7x3.2m, 1b,1hsa, 12kts, 35p; 4x1-75/18, 2x5-37/17
			4	Ziver-i Derya	1866		
	Aynalikavak	1	5	Aynalikavak	1869	No picture	195t, 35.9ppx5.3x1.8m, 1b,1hsa, 10kts, 35p; 1x1-57/37, 2x5-37/17
	Firat	2	6	Firat	1885	No picture	197t, 37.0ppx6.5x2.4m, 1b,1hc, 280hp, 10kts, 55p; 2x1-37/20, 2x5-37/17
			7	Şat	1885		
	Sarıye	3	8	Sarıye	1869	No picture	103t, 30.9x7.5x2.3m, 1b,1hda(sw)
9			Nedim	1869			
10			Bozcaada	1869			
Nasr-ü Hüda	1	11	Nasr-ü Hüda	1904	No picture	198t, 38.6ppx5.4x1.9m, 1b,1vte, 400hp, 10kts, 45p; 1x1-75/37, 2x1-47/42, 1x1-37/20	
DV	İzzeddin	1	1	İzzeddin	1865		1058t, 76.2ppx9.1x3.6m, 2b,1hda(sw), 200hp, 17kts, 130p; 2x1-75/37, 1x1-37/37
	Fuad	1	2	Fuad	1865		1075t, 76.2ppx9.1x3.6m, 2b,1hda(sw), 200hp, 12kts, 130p; 2x175/37, 2x1-25/42
ADV	-	1	1	Resmo	1862		765t
RMON	Feth-ül İslam	2	1	Feth-ül İslam	1865	No picture	335t, 31.5x9.8x1.7m, 2b,2hse, 290hp, 8kts, 50p; iron- 76belt, 76battery, 13CT; 2x1-178/16, 2x1-76/18
	Hizber	1	2	Hizber	1876	No picture	404t, 43.9ppx9.4x1.6m, 1b,1hse, 400hp, 8kts, 51p; iron- 76belt, 76battery, 13CT; 2x1-120/22, 2x1-87/22, 2x1-25/42
AGS	-	3	1	İskenderun	1895		142t
			2	Sakiz	1895		142t
			3	Nur-ül Bahir	1893		295t

[home](#)[World navies yesterday](#)[1905](#)

Persia 01 January 1905

OTHER FIGHTING SHIPS

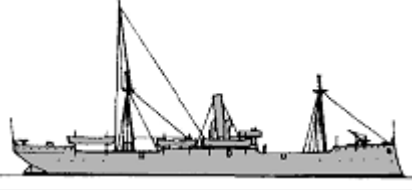
PG	Persepolis	1	1	Persepolis	1885		1200t, 63.1x10.0x5.9m, 1vte, 450hp, 10kts; 1x1-102/27, 1x1-95/19, 2x1-37/40
	Muzaffer	1	2	Muzaffer	1899	No picture	379t, 41.1x7.9x4.0m
PGR	Azerbaijan	1	1	Azerbaijan	1900s	No picture	
	Perebonia	1	2	Perebonia	1900s	No picture	

© Ivan Gogin, 2015

[home](#)[World navies yesterday](#)[1905](#)

Peru 01 January 1905

CRUISERS

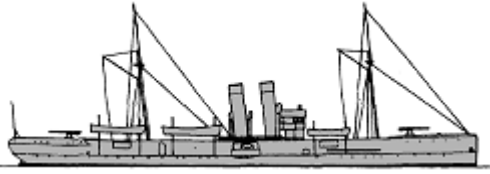
CL	Apurimac	1	1	Apurimac	1850	No picture	1000t; 34guns
CLL	Lima	1	1	Lima	1888		1790t, 76.2x10.7x4.6m, 4b,2hc, 1800hp, 16.2kts, 150p; 2x1-152/26, 3x1-47/40

OTHER FIGHTING SHIPS

PG	Santa Rosa	1	1	Santa Rosa	1883	No picture	2x1-152/26
PGR	Iquitos	1	1	Iquitos	1875	No picture	50t, 23.4x3.7x1.2m, 7.5kts; 1x1-47/40
	América	1	2	América	1904	No picture	240t, 40.5x5.9x1.4m, 2b,2vte, 350hp, 14kts, 26p; 4x1-47/40

© Ivan Gogin, 2015

[home](#)[World navies yesterday](#)[1905](#)

Portugal 01 January 1905

BATTLESHIPS

BC	Vasco da Gama	1	1	Vasco da Gama	1876		3200t, 70.9ppx12.2x6.3m, 2vte, 15.5kts, 260p; steel- 250belt, 75deck, 200shields; 2x1-203/40, 1x1-152/45, 1x1-76/40, 6x1-47/40
----	---------------	---	---	---------------	------	--	--

CRUISERS

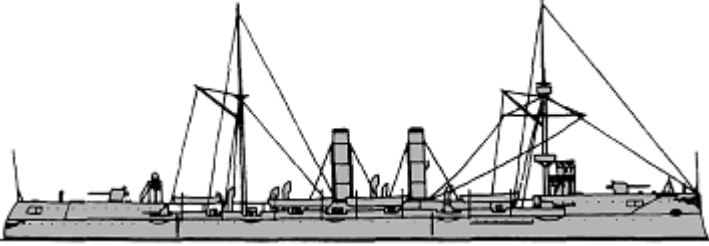
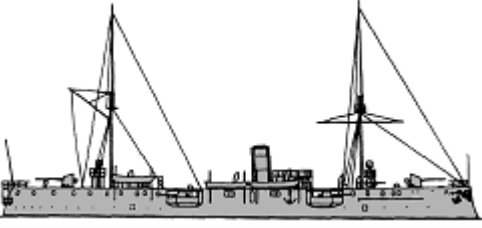
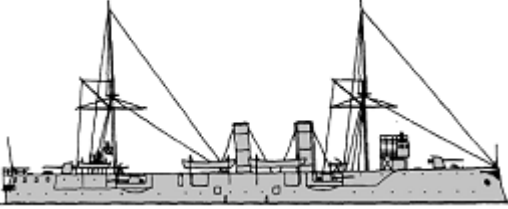
CL	Bartolomeu Dias	1	1	Bartolomeu Dias	1858	No picture	2377t, 63.1ppx11.4x6.3m, 1hr cr, 400hp, 10kts, 473p; 5x1-127/25
	Dom Carlos I	1	2	Dom Carlos I	1898		4253t, 117.0x14.4x5.3m, 12b,2vte, 12500hp, 22kts, 473p; 110slopes, 37deck, 102CT; 4x1-152/45, 8x1-120/44, 14x1-47/40, 2x1-37/25, 2-356TT
	São Gabriel	2	3	São Gabriel	1899		1771t, 75.0x10.8x4.3m, 4b,2vte, 4000hp, 17.5kts, 242p; 20deck, 60CT; 2x1-149/45, 4x1-120/45, 8x1-47/40, 2x1-37/20, 1-356TT
			4	São Rafael	1899		
Rainha Dona Amélia	1	5	Rainha Dona Amélia	1901		1630t, 75.0ppx11.8x4.5m, 4b,2vte, 5000hp, 20kts, 273p; 30deck; 4x1-149/45, 2x1-100/45, 2x1-47/40, 2x1-37/25, 2-356TT	
CLL	Duque da Terceira	1	1	Duque da Terceira	1864	No picture	1406t, 54.9ppx10.4x4.5m, 660hp, 10kts, 194p; 2x1-120/44, 2x1-65/40
	Afonso d'Albuquerque	1	2	Afonso d'Albuquerque	1884	No picture	1092t, 62.0ppx10.1x3.7m, 1360hp, 13kts, 178p; 2x1-152/26, 5x1-127/25, 2x1-47/40

	Adamastor	1	3	Adamastor	1897		1757t, 74.0ppx10.7x4.7m, 4b,2vte, 4000hp, 18kts, 237p; 30deck, 65CT; 2x1-149/27, 4x1-105/37, 4x1-65/40, 2x1-37/25, 3-356TT
--	-----------	---	---	-----------	------	---	--

TORPEDO SHIPS

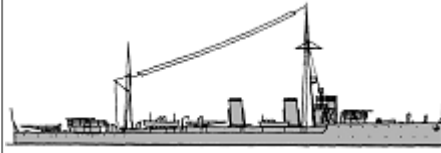
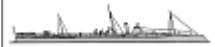
DD	Tejo	1	1	Tejo	1904		522t, 70.0x7.0x2.5m, 4b,2vte, 7000hp, 25kts, 85p; 1x1-100/27, 1x1-65/40, 4x1-47/40, 2x1-356TT
TB	Espadarte	1	1	N°1	1881	No picture	53t, 26.2ppx3.4x1.5m, 1b,1vc, 450hp, 19.7kts, 18p; 2-356TT
	N°2	3	2-4	N°2-4	1886		65t, 36.5ppx3.9x1.0m, 1b,1vc, 700hp, 19kts; 2x5-37/17, 2-356TT

SUBMARINES

SS	Plongeur	1	1	Plongeur	1892	No picture	/100t, 22.0x3.5xm, 2em, /6kts, 6p; 4-356TC
----	----------	---	---	----------	------	------------	--

OTHER FIGHTING SHIPS

PG	Rio Lima	1	1	Rio Lima	1875	No picture	628t, 45.4x8.6x3.2m, 500hp, 11kts, 109p; 1x1-152/26, 2x1-100/27
	Rio Tâmega	2	2	Rio Tâmega	1875	No picture	635t, 45.4ppx8.6x3.2m, 500hp, 11kts, 109p; 2x1-105/32, 2x1-65/40, 1x1-37/20
			3	Rio Sado	1875		
	Tavira	2	4	Tavira	1878	No picture	160t
			5	Faro	1878		
	Mandovi	2	6	Bengo	1879	No picture	462t, 38.2ppx7.5x2.7m, 400hp, 10.5kts, 92p; 1x1-152/26, 2x1-87/21
			7	Mandovi	1879		
	Rio Vouga	1	8	Rio Vouga	1882	No picture	721t, 49.1ppx8.4x3.6m, 600hp, 10kts, 121p; 2x1-47/40
	Vilhena	1	9	Vilhena	1882	No picture	160t, 29.0x4.9x1.8m, 310hp, 12kts, 42p; 1x1-76/16
	Liberal	2	10	Liberal	1884	No picture	560t, 42.5ppx7.9x3.4m, 500hp, 10kts, 109p; 1x1-152/26, 2x1-100/27, 1x1-37/20
			11	Zaire	1884		
	Massabi	2	12	Massabi	1884	No picture	280t, 37.0ppx5.9x2.0m, 375hp, 11kts, 42p; 1x1-76/16
			13	Cacongo	1886		
	Zambeze	1	14	Zambeze	1886	No picture	631t, 43.6ppx7.9x3.3m, 460hp, 10kts, 113p; 3x1-100/27, 1x1-37/20
	Diu	1	15	Diu	1889	No picture	730t, 45.0ppx8.2x4.0m, 700hp, 11.5kts, 124p; 1x1-149/27, 2x1-105/32
Limpopo	1	16	Limpopo	1890	No picture	288t, 37.8x6.4x2.0m, 1b,1vc, 520hp, 11.3kts, 42p; 2x1-47/40	
D. Luiz	1	17	D. Luiz	1895	No picture	789t, 45.9ppx8.3x4.2m, 500hp, 10kts, 120p; 4x1-105/32, 2x1-47/40	
Thomaz Andrea	1	18	Al. Baptista de Andrade	1897	No picture	300t, 41.0ppx8.0x2.0m, 500hp, 12kts; 2x1-47/40	
Chaimite	1	19	Chaimite	1898		341t, 41.0ppx8.0x2.0m, 2vte, 480hp, 11kts, 26p; 2x1-47/40	

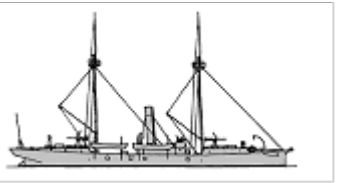
							
	Pedro d'Annaia	3	1-3	Pedro d'Annaia, Diogo Cão, Honório Barreto	1895	No picture	93t, 30.0ppx6.0x0.8m, 500hp, 9kts; 2x1-47/40
PR	Cacheu	4	4-7	Cacheu, Farim, Tête, Sena	1902-1904	No picture	70t, 9kts; 2x1-37/20
	Infante D. Manuel	1	8	Infante D. Manuel	1904	No picture	38t, 24.6x4.0x0.6m, 1b,1vte(sw), 64hp, 7.5kts, 8p; 2x1-37/20

© Ivan Gogin, 2014

[home](#)[World navies yesterday](#)[1905](#)

Romania 01 January 1905

CRUISERS

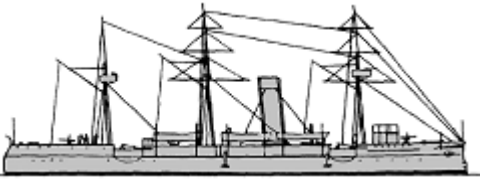
CL	Elisabeta	1	1	Elisabeta	1888		1300t, 73.0x10.2x3.7m, 4b,2vte, 4700hp, 17.3kts, 190p; steel- 86slopes, 43deck; 4x1-149/32, 4x1-57/42, 4x1-37/20, 4-356TT
----	-----------	---	---	-----------	------	--	---

TORPEDO SHIPS

TB	Năluca	3	1-3	Năluca, Sborul, Smeul	1888	No picture	56t, 36.8x3.5x0.9m, 1b,1vc, 540hp, 16kts, 20p; 2x5-37/17, 2-356TT, 1spar torpedo
----	--------	---	-----	-----------------------	------	------------	--

OTHER FIGHTING SHIPS

PG	Grivița	1	1	Grivița	1880	No picture	110t, 60.5x5.2x1.8m, 180hp, 9kts, 30p; 2x1-57/42, 2x1-37/42
PGR	Rahova	3	1-3	Rahova, Smardan, Opanezul	1882	No picture	45t, 8.5kts; 1x1-37/20
	Oltul	3	4	Oltul	1888	No picture	116t, 30.5x4.1x1.7m, 380hp, 13kts, 30p; 1x1-57/42, 1x1-37/42
			5	Siretul	1888		
			6	Bistrița	1888		
	Alexandru cel Bun	1	7	Alexandru cel Bun	1882	No picture	104t
Monteano	3	8-10	Monteano, Olteano, Imeo	1893	No picture	95t, 13.5kts; 1x1-57/42, 2x1-37/42	



© Ivan Gogin, 2015

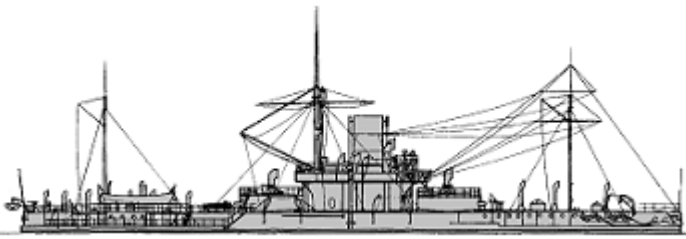
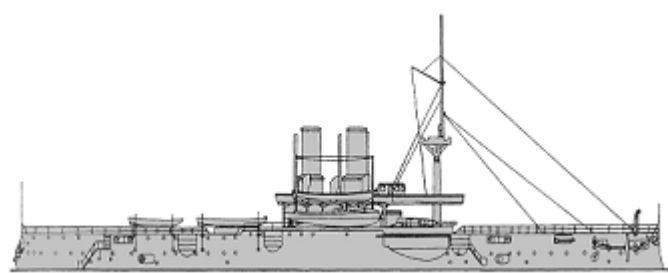
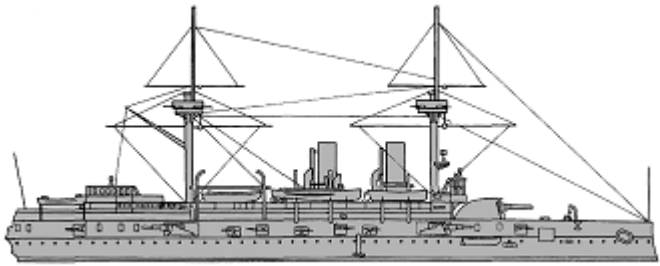
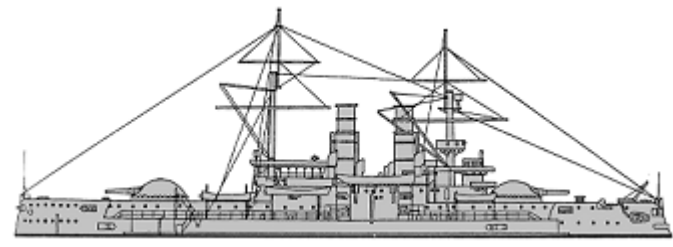

[home](#)[World navies yesterday](#)[1905](#)

Russia 01 January 1905

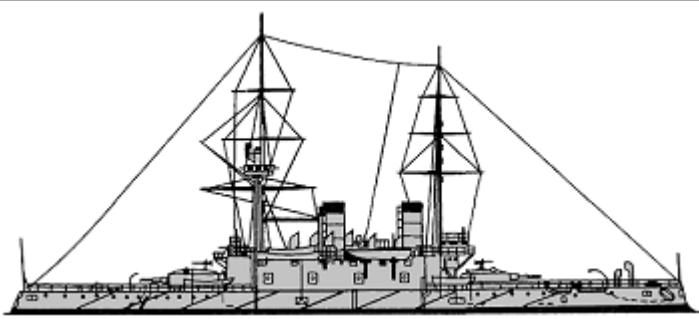
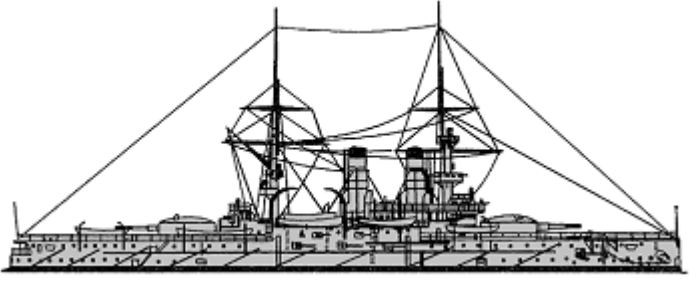
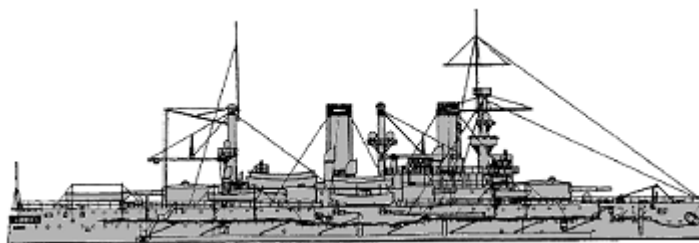
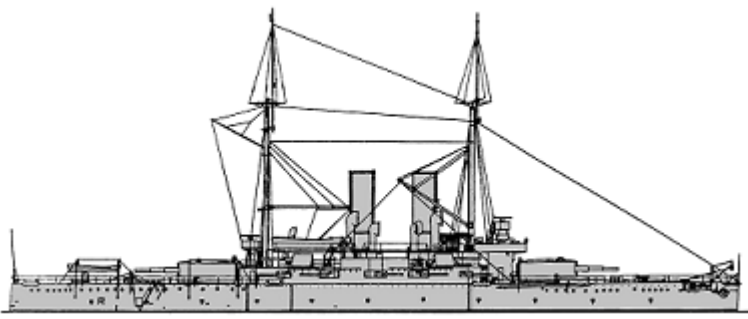
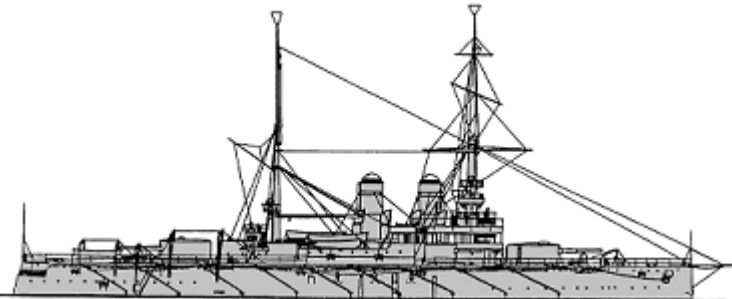
BATTLESHIPS

Pyotr Velikiy	1	1	Pyotr Velikiy	1876		10460t, 103.5x19.0x8.3m, 12b,2vc, 8250hp, 14.3kts, 440p; iron- 356belt, 76deck, 356turrets; 2x2-305/17, 4x1-87/17, 6x1-47/40, 4x5-37/17, 2x4-25/40, 2-381TT
Yekaterina II	4	2	Yekaterina II	1888		11048(2)-10930(3)-10181(4)-10750(5)t, 103.5x21.0x8.8m, 14b,2vc(2,3)-16b,2vte(4,5), 9100(2,3)-13000(4,5)hp, 15(2,3)-16(4)-16.5(5)kts, 633-645p; compound(2-4)-steel(5), 406belt, 38(2)-57(3-5)deck, 305redoubt, 292(2-4)-305(5)CT; 3x2-305/27(2,4), 3x2-305/32(3,5), 7x1-152/32, 2x1-63/17(3-5), 8x1-47/40(5), 8x5-47/22(2-4), 10x1-37/20(5), 4x5-37/17(2-4), 7-381TT, 100mines
		3	Chesma	1889		
		4	Sinop	1889		
		5	Georgiy Pobedonosets	1893		
Imperator Aleksandr II	2	6	Imperator Aleksandr II	1890		10010(6)-9672(7)t, 105.6x20.4x7.8m, 12b,2vc(6)-16b,2hte(7), 8500hp, 15.3kts, 616p; compound- 356belt, 63deck, 254barbette(6), 254turret(7), 254(6)-203(7)CT; 1x2-305/27, 4x1-229/32(7), 5x1-203/43(6), 8x1-152/44(6), 1x1-152/44(7), 8x1-152/32(7), 8x1-75/48(7), 4x1-63/17(6), 2x1-63/17(7), 10x1-47/40(6), 16x1-47/40(7), 6-381TT(7)
		7	Imperator Nikolay I	1891		
Dvenadtsat Apostolov	1	8	Dvenadtsat Apostolov	1892		8709t, 104.2x18.3x8.4m, 8b,2vte, 8750hp, 15.7kts, 599p; compound- 356belt, 63deck, 305barbette, 203CT; 2x2-305/27, 4x1-152/32, 12x1-47/40, 10x1-37/20, 4x5-37/17, 6-381TT
Navarin	1	9	Navarin	1896		10206t, 109.0x20.4x8.4m, 12b,2vte, 9140hp, 15.5kts, 622p; compound- 406belt, 76deck, 305turrets, 254CT; 2x2-305/32, 8x1-152/32, 4x1-1200/43, 2x1-63/17, 4x1-57/40, 18x1-

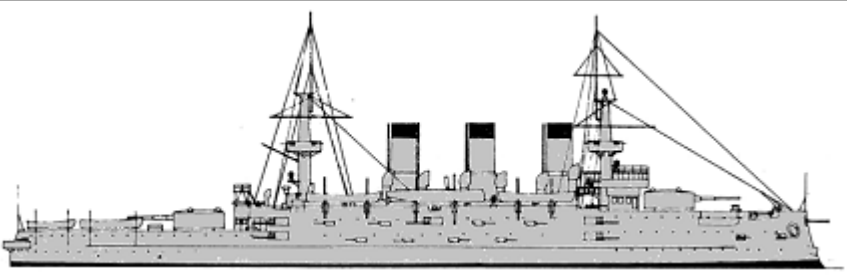
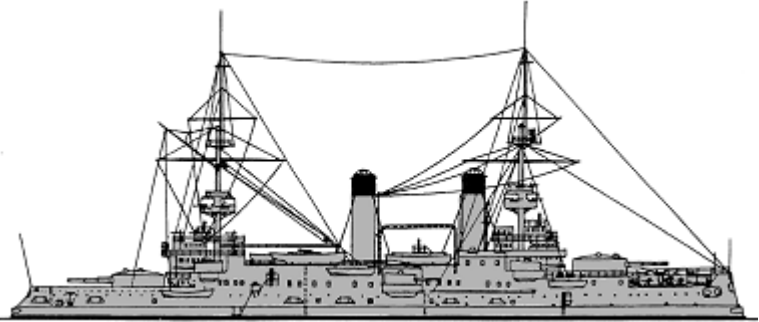
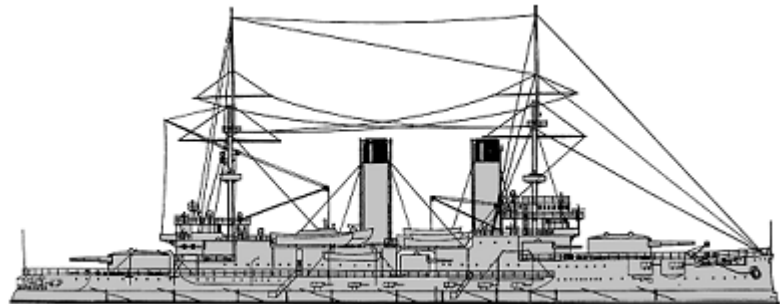
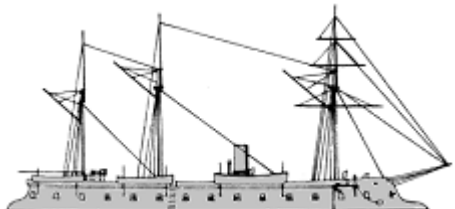
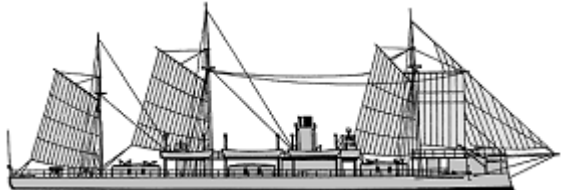
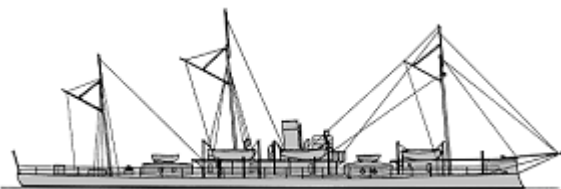
					47/40, 12x1-37/20, 6-381TT	
	Sisoy Velikiy	1 10	Sisouy Velikiy	1896		10400t, 107.2x20.7x7.8m, 12b, 2vte, 8500hp, 15.7kts, 582p; NS- 406belt, 76deck, 305turrets, 203CT; 2x2-305/38, 6x1-152/44, 4x1-120/43, 2x1-63/17, 12x1-47/40, 2x1-37/20, 12x5-37/17, 6-381TT
BB	Poltava	1 11	Sevastopol	1898		11842t, 114.3x21.3x7.9m, 16b,2vte, 10600hp, 16.5kts, 652p; Harvey- 368belt, 76deck, 254turrets, 229CT; 2x2-305/38, (4x2+4x1)-152/44, 12x1-47/40, 28x1-37/20, 2-450TT, 4-381TT, 50mines
	Tri Svyatitelya	1 12	Tri Svyatitelya	1897		13318t, 115.1x22.3x8.7m, 14b,2vte, 11300hp, 753p; Harvey+NS- 457belt, 76deck, 406turrets, 305CT; 2x2-305/38, 14x1-152/44, 4x1-120/43, 2x1-63/17, 10x1-47/40, 10x1-37/20, 6-381TT
	Rostislav	1 13	Rostislav	1898		10140t, 107.2x20.7x6.7m, 12b,2vte, 8700hp, 15.6kts, 632p; Harvey- 356belt, 76deck, 254turrets, 152CT; 2x2-254/43, 4x2-152/44, 2x1-63/17, 12x1-47/40, 14x1-37/20, 6-381TT
	Peresvet	1 14	Oslyabya	1901		12683t, 132.4x21.8x7.9m, 32b,3vte, 15000hp, 18.5kts, 752p; KC+Harvey- 229belt, 76deck, 229turrets, 152CT; 2x2-254/43, 11x1-152/44, 20x1-75/48, 2x1-64/17, 20x1-47/40, 8x1-37/20, 5-381TT

						
Tsesarevich	1	15	Tsesarevich	1903		13110t, 118.5x23.2x7.9m, 20b,2vte, 16300hp, 18kts, 779p; 250belt, 90deck, 250turrets, 254CT; 2x2-305/38, 6x2-152/44, 20x1-75/48, 20x1-47/40, 8x1-37/20, 4-381TT
Borodino	4	16	Imperator Aleksandr III	1903		15275t, 121.0x23.2x8.0m, 20b,2vte, 16300hp, 17.5-17.8kts, 835p; 194belt, 63deck, 254turrets, 203CT; 2x2-305/38, 6x2-152/44, 20x1-75/48, 2x1-63/17, 20x1-47/40, 2x1-37/20, 4-381TT
		17	Borodino	1904		
		18	Oryol	1904		
		19	Knyaz Suvorov	1904		
Pervenets	3	1	Pervenets	1863		4000t, 67.6(1)-69.4(2)-67.3(3)x16.2x4.6m, 2b,1hda(1)-4b,1hda(2,3), 1067(1)-1232(2)-870(3)hp, 8(1,2)-9(3)kts, 394-459p; iron- 114belt, 29deck(3), 114battery, 114CT(2,3); 6x1-203/19(1), 12x1-203/19(2), 8x1-203/19(3), 2x1-152/32(1), 4x1-152/25(1), 2x1-152/25(2), 7x1-152/32(3), 2x1-120/43(1), 1x1-107/17(1), 2x1-87/17(1), 2x1-63/17, 2x1-47/40(1), 4x1-47/40(3), 4x1-37/20(3), 5x5-37/17(1)
		2	Ne Tron Menya	1865		
		3	Kreml	1867		
Admiral Lazarev	2	4	Admiral Lazarev	1869		3820(4)-3768(5)t, 77.7x13.1x6.2m, 4b,1hda, 2020hp, 10.5(4)-11(5)kts, 274p; iron- 114side, 114turrets, 127CT; 3x1-279/18, 2x1-63/17, 5x1-47/40, 2x1-37/20
		5	Admiral Greyg	1869		
Admiral Spiridov	2	6	Admiral Spiridov	1869		3925(6)-3851(7)t, 77.5x13.1x6.2m, 4b,1hda, 2030hp, 10.5kts, 260p; iron- 152side, 152(6)-178(7)turrets; 2x1-279/18, 2x1-63/17, 1x1-47/40, 4x1-37/20
		7	Admiral Chichagov	1869		
Rusalka	1	8	Charodeyka	1869		2100t, 62.9x12.8x3.8m, 2b,2hda, 875hp, 8.5kts, 178p; iron- 114side, 25deck, 152turrets; 2x2-229/19, 4x1-87/17, 5x5-37/17

Admiral Ushakov	3	9	Admiral Ushakov	1897		4648(9)-4792(10)-4152(11)t, 86.4x15.9x6.1m, 4b,2hte, 4250hp, 16(9,10)-15(11)kts, 406p; Harvey- 254belt, 51deck, 178turrets, 178CT; 2x2-254/43(9,10), (1x2+1x1)-254/43(11), 4x1-120/43, 2x1-63/17, 6x1-47/40(9,10), 10x1-47/40(11), 18x1-37/20(9,10), 12x1-37/20(11), 2-381TT
		10	Admiral Senyavin	1897		
		11	General-Admiral Apraksin	1899		

CRUISERS

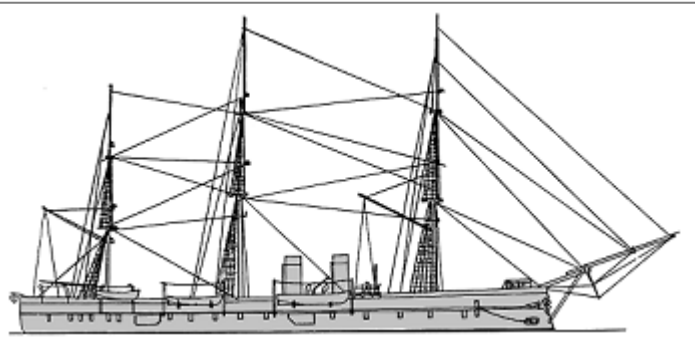
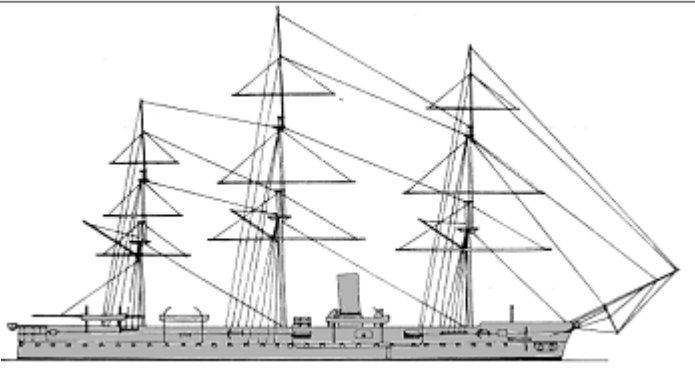
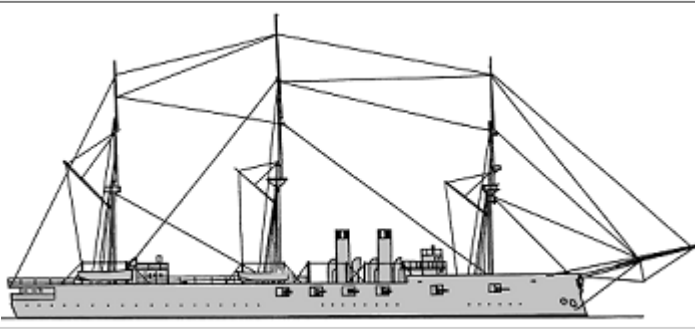
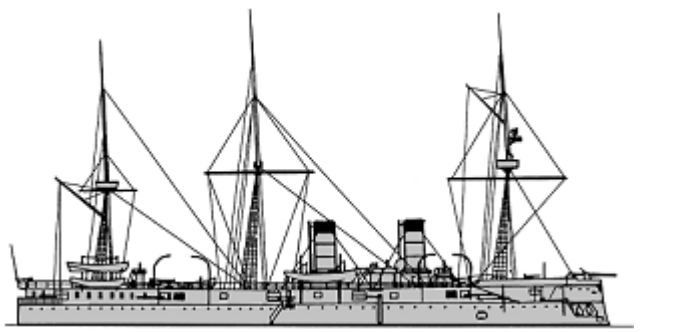
Knyaz Pozharskiy	1	1	Knyaz Pozharskiy	1869		5138t, 83.1x14.9x7.5m, 8b,1hda, 2835hp, 11.7kts, 495p; iron- 102belt, 114battery; 1x1-152/23, 4x1-87/17, 2x1-63/17, 4x1-47/40, 6x5-37/17
General-Admiral	2	2	General-Admiral	1875		5031(2)-4838(3)t, 91.0(2)-86.9(3)x14.6x7.0(2)-7.3(3)m, 5b,1vc(2)-4b,1vc(3), 4470(2)-5222(3)hp, 12.3(2)-13.2(3)kts, 490p; iron- 152belt, 25deck; 4x1-203/28(3), 5x1-152/25(3), 4x1-152/23(2), 6x1-87/21, 6x1-47/40(2), 8x1-37/20(2), 10x5-37/17(3), 1-381TT(2), 3-381TT(3)
		3	Gertsog Edinburgskiy	1877		
Minin	1	4	Minin	1878		6136t, 89.9x15.1x7.7m, 18b,1vte, 4000hp, 12.2kts, 545p; compound- 178belt, 25deck; 4x1-203/28, 6x1-152/44, 4x1-87/17, 6x1-75/48, 2x1-63/17, 8x1-47/40, 2-381TT, 150mines
Vladimir Monomakh	1	5	Vladimir Monomakh	1883		6000t, 93.3x15.9x8.0m, 8b,2vc, 7000hp, 15.2kts, 566p; compound- 152belt, 13deck; 5x1-152/44, 6x1-120/43, 2x1-63/17, 16x1-47/40, 4x1-37/20, 3-381TT

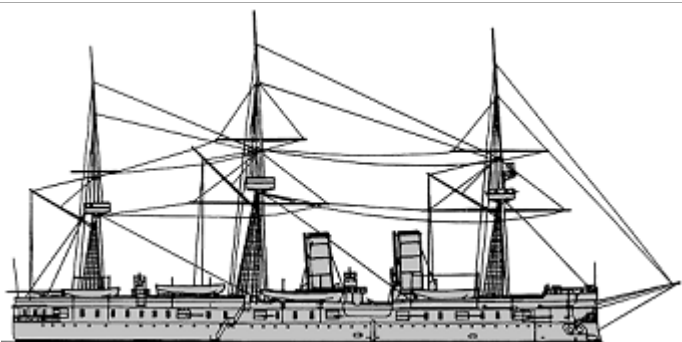
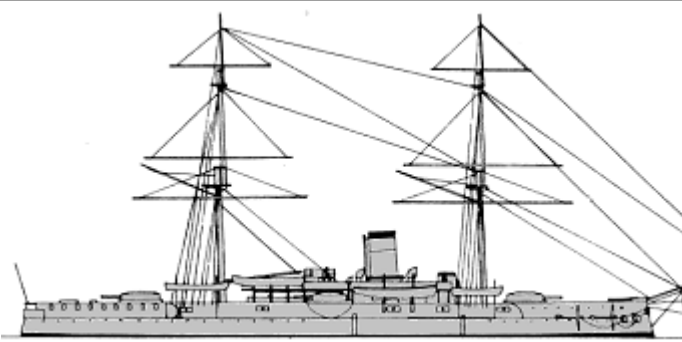
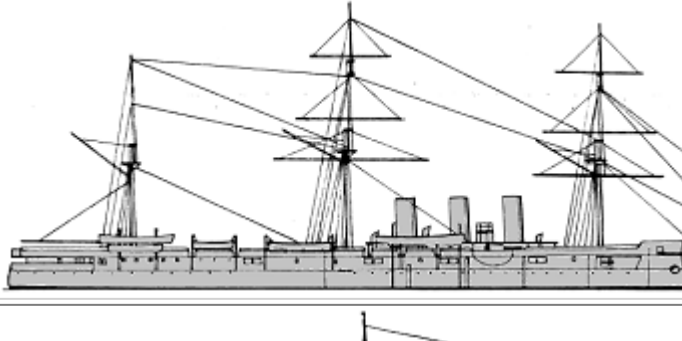
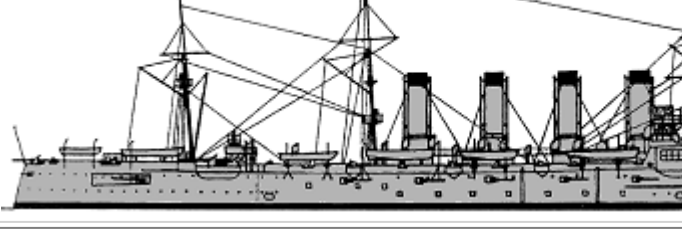
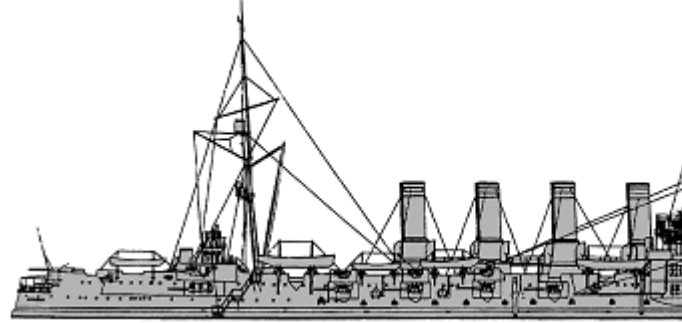
CA	Dmitriy Donskoy	1	6	Dmitriy Donskoy	1885		6200t, 93.4x15.9x7.9m, 8b,1vc, 7000hp, 16.5kts, 571p; compound- 152belt, 13deck; 6x1-152/44, 10x1-120/43, 2x1-63/17, 6x1-47/40, 10x1-37/20, 5-381TT
	Admiral Nakhimov	1	7	Admiral Nakhimov	1888		8524t, 103.3x18.6x8.4m, 12b,2vc, 8000hp, 17kts, 570p; compound- 254belt, 76deck, 203barbettes, 152CT; 4x2-203/33, 10x1-152/32, 2x1-63/17, 12x1-47/40, 6x1-37/20, 3-381TT, 40mines
	Pamyat Azova	1	8	Pamyat Azova	1890		6674t, 117.2x17.2x8.2m, 18b,2vte, 8500hp, 17kts, 640p; compound- 152belt, 63deck, 51shields, 38CT; 2x1-203/33, 13x1-152/32, 2x1-63/17, 7x1-47/40, 8x5-37/17, 3-381TT
	Rossiya	1	9	Rossiya	1897		12195t, 147.8x20.9x7.9m, 32b,3vte, 17000hp, 19.7kts, 839p; Harvey- 203belt, 76deck, 127casemates, 305CT; 4x1-203/43, 22x1-152/44, 6x1-75/48, 20x1-47/40, 18x1-37/20, 5-381TT
	Gromoboy	1	10	Gromoboy	1899		12455t, 146.6x20.9x7.9m, 32b,3vte, 14500hp, 19kts, 874p; 152belt, 76deck, 127casemates, 305CT; 4x1-203/43, 22x1-152/44, 18x1-75/48, 12x1-47/40, 18x1-37/20, 4-381TT
							3537t, 79.4x13.7x5.3m, 10b,1hc, 3000hp, 11.5kts, 396p; steel- 38deck; 4x1-

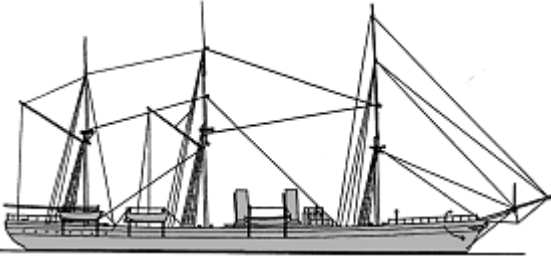
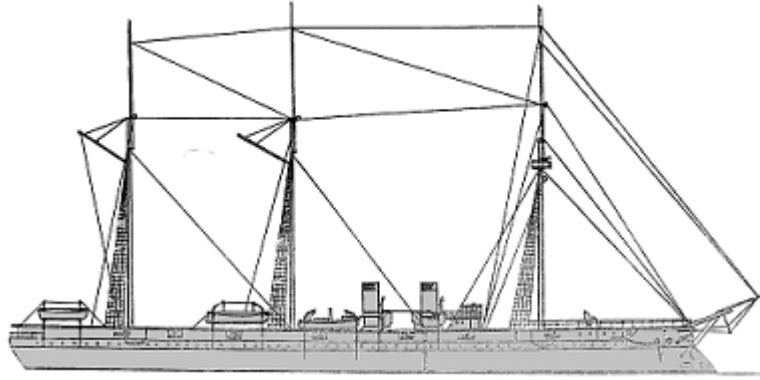
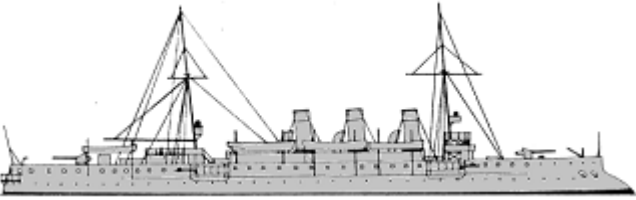
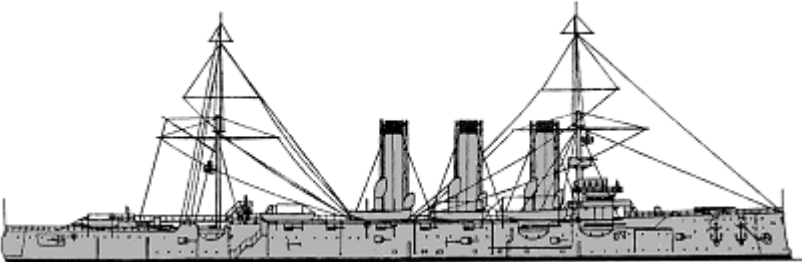
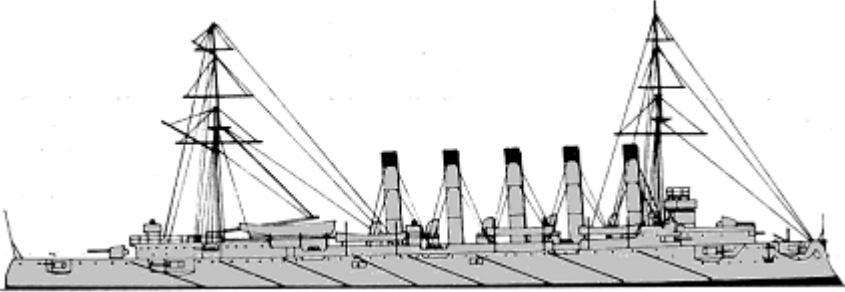

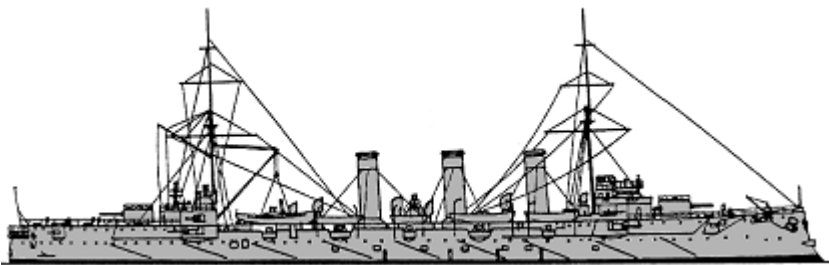
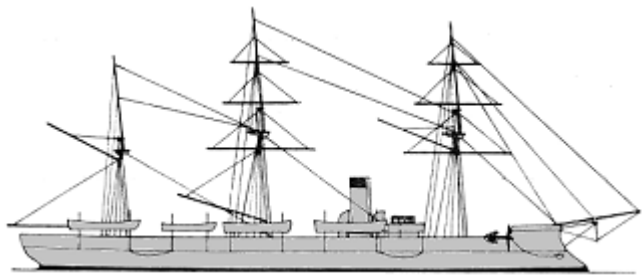
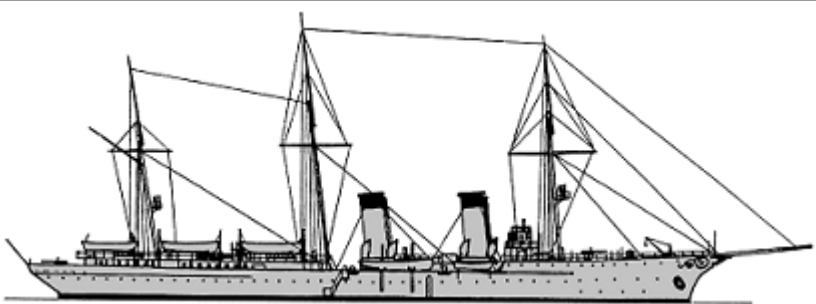
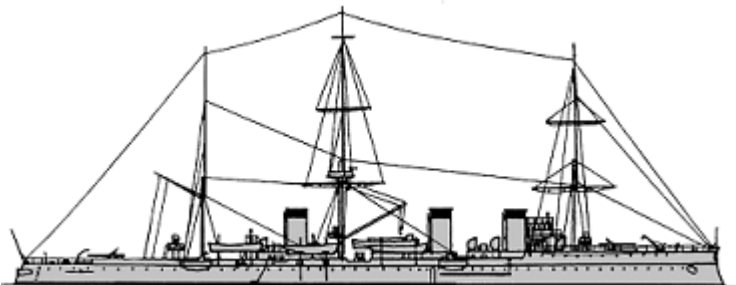
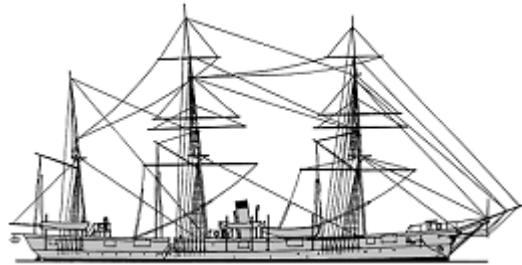

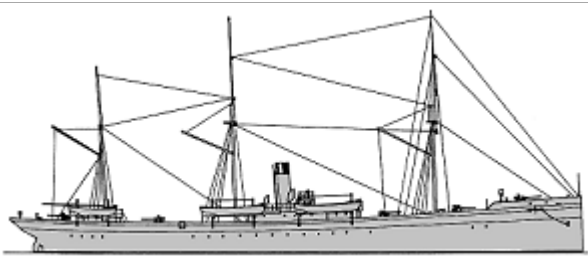
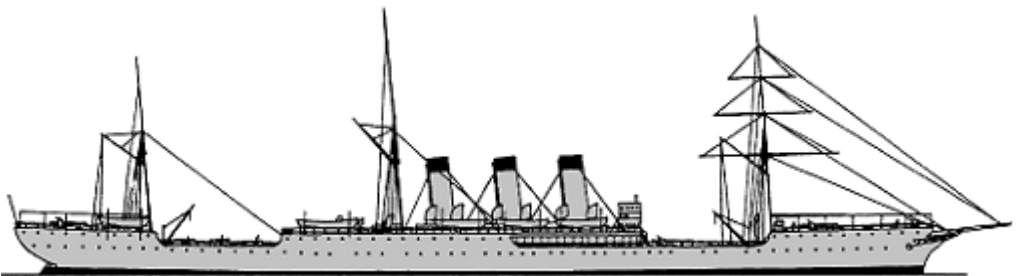
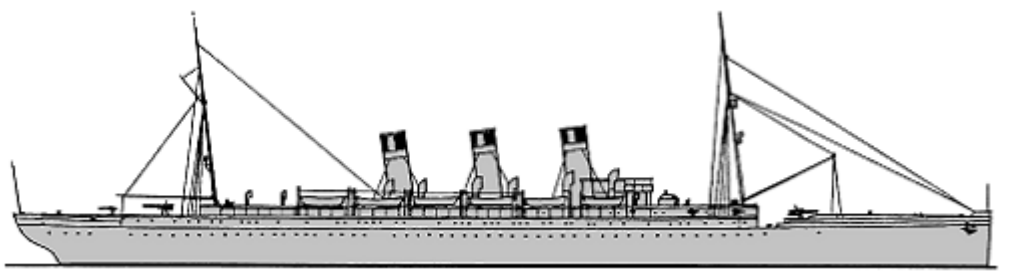
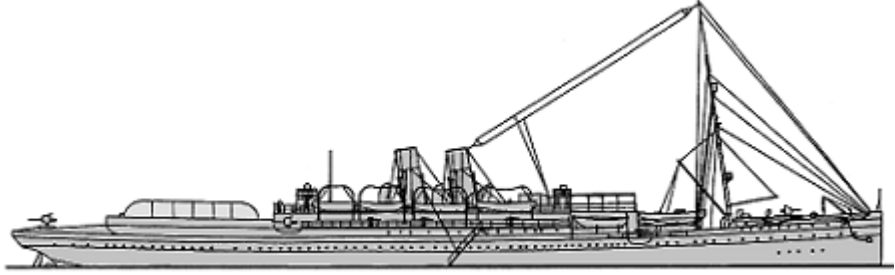
CL	Vityaz	1	1	Rynda	1886		152/25, 2x1-87/21, 2x1-47/40, 10x5-37/17, 4-381TT
	Admiral Kornilov	1	2	Admiral Kornilov	1888		5880t, 112.2x14.8x7.8m, 8b,2hte, 5977hp, 17.6kts, 479p; steel- 63deck, 76CT; 14x1-152/32, 6x1-47/40, 10x5-37/17, 6-381TT
	Svetlana	1	3	Svetlana	1898		3862t, 101.0x13.0x5.7m, 18b,2vte, 8500hp, 21.6kts, 401p; NS- 63slopes, 38deck, 102CT; 6x1-152/44, 10x1-47/40, 2-381TT, 20mines
	Pallada	2	4	Diana	1901		6932(4)-6897(5)t, 126.8x16.8x6.5m, 24b,3vte, 11610hp, 19.2kts, 570p; NS- 63slopes, 38deck, 25(5)shields, 152CT; 8x1-152/44, 24x1-75/48, 8x1-37/20, 3-381TT
			5	Avrora	1903		
	Askold	1	6	Askold	1901		5950t, 132.1x15.6x6.2m, 19b,3vte, 19000hp, 23kts, 534p; 76slopes, 51deck, 25shields, 152CT; 12x1-152/44, 12x1-75/48, 2x1-63/17, 8x1-47/40, 2x1-37/20, 5-381TT
Bogatyr	2	7	Bogatyr	1902		6700(7)-7400(8)t, 134.0x16.6x6.3m, 16b,2vte, 19500hp, 23kts, 581p; 70slopes, 35deck, 125(7)-127(8)turrets, 140CT; (2x2+8x1)-152/44, 12x1-75/48, 8x1-47/40, 2x5-37/17, 4-381TT(7), 2-381TT(8)	
		8	Oleg	1904			



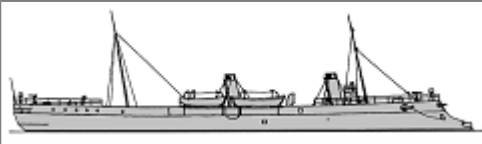

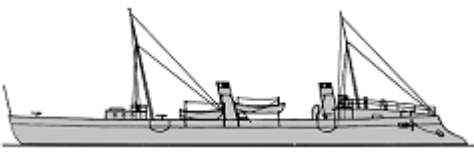



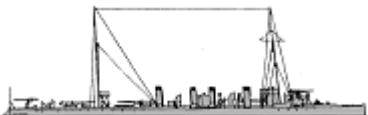
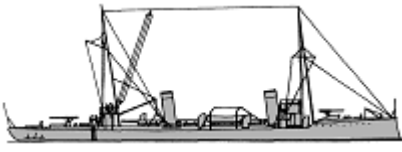

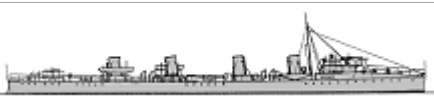

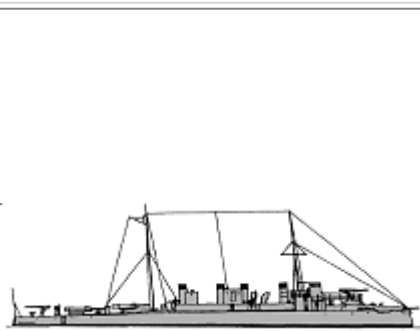
							
CLL	Pamyat Merkuriya	1	1	Pamyat Merkuriya	1880		2997t, 90.0x12.4x6.0m, 6b,1hc, 3000hp, 14kts, 343p; 6x1-152/25, 2x1-63/17, 4x1-47/40, 2x1-37/20, 2x5-37/17, 2-381TT, 180mines
	Almaz	1	2	Almaz	1903		3285t, 111.5x13.3x5.3m, 16b,2vte, 7500hp, 19kts, 295p; 4x1-75/48, 8x1-47/40
	Zhemchug	2	3	Zhemchug	1904		3333t, 110.9x12.8x5.0m, 16b,3vte, 17000hp, 24kts, 350p; NS- 50slopes, 30deck, 30CT; 8x1-120/43, 6x1-47/40, 2x1-37/20, 3-450TT
		4	Izumrud	1904			
SL	Kreyser	8	1	Kreyser	1876		1334-1449t, 70.5x10.0-10.1x5.1m, 4b,1hc, 1383-1786hp, 10-13.5kts, 188-199p; 2x1-152/25(1,2), 1x1-152/25(5), 3x1-152/25(4,6,7), 2x1-152/23(3,5), 4x1-107/17(1-3), 4x1-87/21(5-7), 2x1-87/21(4), 1x1-63/17(1-3,5-7), 2x1-44/41(1,2), 4x1-44/41(3), 4x5-37/17(1,2), 6x5-37/17(3,5-7), 1x5-37/21(4), 1-381TT(1,3-7)
			2	Dzhigit	1877		
			3	Razboynik	1879		
			4	Plastun	1879		
			5	Strelok	1880		
			6	Vestnik	1881		
			7	Oprichnik	1881		
			1	Aziya	1874		2449t, 82.0x10.7xm, 1100hp, 15.6kts; 2x1-152/23, 7x1-107/17
			2	Afrika	1878		2590t, 90.2x10.9xm, 1417hp, 12.8kts; 5x1-152/23, 4x1-107/17, 2x1-87/21

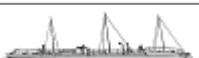
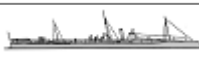











AMC -	10					
		3	Lena	1896		10675t, 145.5x15.6m, 13500hp, 19.5kts; 6x1-120/43, 6x1-75/48
		4	Kuban	1888		12000t, 164.2x17.1m, 13300hp, 18.5kts; 2x1-120/43, 4x1-75/48, 8x1-57/40
		5	Don	1890		10000t, 158.4x15.5m, 16410hp, 19.5kts; 2x1-120/43, 5x1-75/48, 8x1-57/40
		6	Ural	1890		10500t, 161.1x15.8m, 17000hp, 19kts; 2x1-120/43, 4x1-75/48, 8x1-57/40
		7	Terek	1889		10000t, 139.9x17.1m, 13300hp, 19kts; 2x1-120/43, 4x1-75/48, 8x1-57/40
		8	Dnepr	1894		9500t, 140.8x15.9m, 11500hp, 19kts; 7x1-120/43, 8x1-47/40, 10x1-37/20
		9	Rion	1901		14614t, 143.3x17.7m, 15910hp, 20kts; 8x1-20/43, 7x1-75/48, 4x1-47/40
		10	Rus	1887		9600t, 141.0x14.9m, 9000hp, 18.5kts; 4x1-75/48, 10x1-57/40, 9balloons









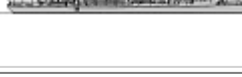

TORPEDO SHIPS

Leytenant Ilyin	1	1	Leytenant Ilyin	1887		714t, 72.3x7.4x3.2m, 6b,2vte, 3500hp, 20.8kts, 128p; steel- 19deck; 7x1-47/40, 6x5-47/22, 6x5-37/17, (5+2x1)-381TT
Kapitan Saken	1	2	Kapitan Saken	1889		742t, 71.6x7.4x3.1m, 6b,2vte, 3000hp, 18.3kts, 102p; steel- 13deck; 6x1-47/40, 4x5-37/17, (1+2x1)-381TT

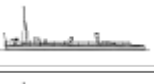
PGT							
	Kazarskiy	5	3	Kazarskiy	1890		432t, 60.2x7.4x3.5m, 2b,1vte, 3500hp, 21-22.5kts, 65p; 6x1-47/40, 3x1-37/20, (1+1x1)-381TT
			4	Voevoda	1892		
			5	Posadnik	1892		
			6	Gaydamak	1894		
			7	Griden	1895		
Abrek	1	8	Abrek	1897		675t, 65.5x7.8x3.4m, 4b,2vte, 4500hp, 21.2kts, 88p; 2x1-75/48, 4x1-47/40, (1+1x1)-450TT	
DD	Sokol	1	1	Prytkiy	1895		240t, 57.9x5.6x2.3m, 8b,2vte, 3800hp, 29kts, 54p; 1x1-75/48, 3x1-47/40, 2x1-381TT
	Krechet	21	2	Poslushny	1900		305t, 57.9-61.0x5.6-5.7x2.3-2.4m, 8b,2vte(2-6,11)-4b,2vte(7-10,12-22), 3800hp, 26.5-27.5kts, 51-58p; 1x1-75/48, 3x1-47/40, 2x1-381TT
			3	Pylkiy	1900		
			4	Prochny	1902		
			5	Porazhayushchiy	1902		
			6	Pronzitelny	1902		
			7	Prozorlivy	1902		
			8	Rezvy	1902		
			9	Retivy	1902		
			10	Ryany	1902		
			11	Podvizhny	1902		
			12	Strogiy	1902		
			13	Smetlivy	1902		
			14	Svirepy	1902		
			15	Stremitelny	1902		
	16	Serdity	1903				
	17	Smely	1903				
	18	Storozhevoy	1903				
	19	Razyashchiy	1903				
	20	Silny	1903				
	21	Skory	1903				
	22	Statny	1904				
	Kit	4	23	Bditelny	1900		445t, 63.5x7.0x2.7-2.9m, 4b,2vte, 6000hp, 27kts, 64p; 1x1-75/48, 5x1-47/40, 3x1-381TT
			24	Besposhchadny	1900		
			25	Besshumny	1900		
26			Besstrashny	1900			

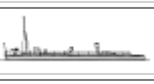

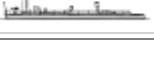

Som	1	27	Boevoy	1900		412t, 64.9x6.6x2.9m, 4b,2vte, 6000hp, 27.5kts, 62p; 1x1-75/48, 5x1-47/40, 2x1-381TT
Forel	2	28	Vlastny	1902		347t, 56.6x5.9x3.0m, 4b,2vte, 5200hp, 26.5kts, 64p; 1x1-75/48, 5x1-47/40, 2x1-381TT
		29	Grozovoy	1902		
Boykiy	12	30	Boykiy	1902		520-530t, 64.0x6.4x2.4-2.5m, 4b,2vte, 5700hp, 26kts, 69p; 1x1-75/48, 5x1-47/40, (1+2x1)-381TT, 18mines
		31	Buyny	1902		
		32	Bravy	1902		
		33	Bystry	1902		
		34	Blestyashchiy	1902		
		35	Bodry	1902		
		36	Bedovy	1902		
		37	Bezuprechny	1902		
		38	Zavetny	1903		
		39	Zavidny	1903		
		40	Grozny	1904		
41	Gromkiy	1904				
Vzryv	1	1	Vzryv	1877		160t, 39.6x4.9x3.4m, 2b,1vc, 800hp, 13.5kts, 33p; 4x5-37/17, 2-381TT
Batum	1	2	No251	1880		48t, 30.6x3.7x1.9m, 1b,1vc, 500hp, 15.2kts, 21p; 2x5-37/17, 2-381TT
Sukhum	1	3	No257	1883		64t, 34.4x3.8x2.0m, 1b,1vc, 704hp, 17.9kts, 16p; 2x5-37/17, 2-381TT
Poti	1	4	No258	1883		63t, 38.0x3.1x2.0m, 1b,1vc, 575hp, 18.5kts, 18p; 2x5-37/17, 2-381TT
Gagry	1	5	No254	1884		80t, 36.8x4.1x2.0m, 1b,1vc, 600hp, 17.8kts, 18p; 1x1-37/20, 1x5-37/17, 2-381TT
Gelendzhik	1	6	No255	1884		75t, 37.4x3.8x2.1m, 1b,1vc, 520hp, 18kts, 16p; 1x1-37/20, 1x5-37/17, 2-381TT
No1	1	7	No101	1885		68t, 38.8x3.9x1.4m, 1b,2vc, 472hp, 16.5kts, 21p; 2x5-37/17, 2-381TT
No17	3	8-10	No106, 107, 267	1886-1888		74(8,9)-77(10)t, 38.9x3.5x2.3m, 1b,1vc, 296(8,9)-520(10)hp, 15.8(8,9)-17.5(10)kts, 21p; 4x5-37/17(8,9), 2x5-37/17(10), 2-381TT
Sveaborg	2	11	No205	1886		96(11)-108(12)t, 46.8x3.4(11)-3.7(12)x2.6(11)-2.5(12)m, 1b,1vte, 737(11)-837(12)hp, 19.2(11)-19.7(12)kts, 21p; 2x5-37/17, 2-381TT
		12	No206	1886		
Vyborg	1	13	No102	1886		150t, 45.1x5.2x2.1m, 2b,2vc, 1300hp, 20kts, 24p; 2x5-37/17, 2-381TT
Abo	3	14-16	No108-110	1886		76t, 38.5x4.5x1.9m, 1b,1vc, 640hp, 19.3-20kts, 21p; 4x5-37/17, 2-381TT

TB	Yalta	6	17-22	No261-266	1886		85-90t, 38.6x4.6x2.0m, 1b,1vte, 900hp, 20-20.8kts, 18p; 2x5-37/17, 2-381TT
	Yanchikhe	2	23, 24	No201, 202	1889		76t, 39.0x4.5x1.9m, 1b,1vc, 970hp, 16.8-17.2kts, 21p; 2x5-37/17, 2-381TT
	Adler	1	25	No259	1890		164t, 46.9x5.1x2.0m, 2b,2vte, 2000hp, 26.7kts, 25p; 2x5-37/17, (1+2x1)-381TT
	Anakriya	1	26	No260	1890		100t, 38.6x4.8x2.1m, 2b,1vte, 1100hp, 21kts, 21p; 2x5-37/17, (1+1x1)-381TT
	Nargen	1	27	No203	1891		153t, 47.3x5.0x2.6m, 2b,2vte, 2039hp, 19.5kts, 21p; 3x5-37/17, (1+2x1)-381TT
	Biorke	4	28-31	No111-114	1891-1892		81t, 38.4x4.5x2.6m, 1b,1vte, 1000-1100hp, 17.8-19kts, 21p; 2x5-37/17, 2x1-381TT
	Borgo	1	32	No117	1891		118t, 41.7x4.5x2.6m, 1b,1vte, 1245hp, 20kts, 21p; 2x5-37/17, (1+1x1)-381TT
	Anapa	2	33, 34	No252, 253	1891-1892		96t, 38.4x4.5x2.6m, 1b,1vte, 1000-1100hp, 17.2-19kts, 18p; 2x5-37/17, 2x1-381TT
	Dago	4	35	No118	1892		101-105t, 46.5-46.8x3.9x2.3-2.6m, 1b,1vte, 1000-1030hp, 16.2-19kts, 21p; 2x5-47/22(35), 2x5-37/17(36-38), (1+1x1)-381TT
			36	No256	1892		
			37	No123	1892		
			38	No124	1892		
	Pernov	1	39	No103	1892		120t, 42.0x4.5x2.1m, 2b,2vte, 2000hp, 26kts, 21p; 2x5-37/17, (1+2x1)-381TT
	Tosna	2	40, 41	No115, 116	1893		85-87t, 38.7x4.6x2.0m, 1b,1vte, 1000hp, 20kts, 21p; 2x5-47/22, (1+1x1)-381TT
	Aspe	4	42	No121	1895		105t, 38.8x4.8x2.1m, 2b,1vte, 1300hp, 20kts, 21p; 2x5-37/17, (1+1x1)-381TT
			43	No122	1895		
			44	No125	1894		
45			No126	1894			
Sestroretsk	1	46	No104	1894		80t, 36.8x4.2x2.6m, 1b,1vte, 1300hp, 23kts, 21p; 2x5-37/17, (1+1x1)-381TT	
		47	No119	1895			
		48	No120	1895			
		49	No127	1898			
		50	No128	1898			
		51	No129	1899			
		52	No130	1900			
		53	No133	1897			
		54	No134	1897			
		55	No135	1897			



No119	20	56	No136	1897		120t, 42.0x4.5x2.1m, 2b,2vte, 2000hp, 19.5-23.2kts, 21p; 2x5-37/17, (1+2x1)-381TT	
		57	No137	1897			
		58	No138	1897			
		59	No139	1897			
		60	No140	1897			
		61	No141	1897			
		62	No142	1897			
		63	No270	1897			
		64	No271	1897			
		65	No272	1899			
		66	No273	1899			
No131	3	67	No131	1897		100t, 38.7x5.2x2.0m, 2b,2vte, 1000hp, 21kts, 18p; 2x5-37/17, (1+1x1)-381TT	
		68	No132	1896			
		69	No268	1895			
No208	3	70	No209	1899		130t, 42.0x4.5x2.1m, 2b,2vte, 1460hp, 18.5kts, 21p; 2x5-37/17, (1+2x1)-381TT	
		71	No210	1899			
		72	No211	1900			
No212	2	73	No212	1902		204t, 53.5x5.3x1.6m, 4b,2vte, 3800hp, 24kts, 26p; 3x1-37/20, (1+2x1)-381TT	
		74	No213	1902			
No214	9	75	No214	1903		152t, 45.1x4.7x2.7m, 2b,2vte, 3700hp, 29kts, 28p; 2x1-47/40, 1x2-381TT	
		76	No215	1903			
		77	No216	1903			
		78	No217	1903			
		79	No218	1903			
		80	No219	1903			
		81	No220	1903			
		82	No221	1903			
		83	No222	1902			
TB2cl	Oryol	68	1-68	No1-12, 15, 17-20, 22, 25-37, 39, 40, 42-73, 95, 97, 143	1877-1878		23t, 21.7x2.7x1.7m, 1b,1vc, 220hp, 16kts, 7p; 1x1-381TT
	Chizhik	3	69-72	No91-93	1877-1878		23t, 21.7x3.0x1.1m, 1b,1vc, 220hp, 16kts, 9p; 1x1-381TT
	Galka	1	73	No13	1878		34t, 22.1x3.1x1.6m, 1b,1vc, 220hp, 13kts, 9p; 1x1-381TT
	Kasatka	1	74	No14	1878		28t, 21.8x3.0x1.9m, 1b,1vc, 312hp, 13kts, 9p; 1x1-381TT
	Podorozhnik	1	75	No94	1878		20t, 21.5x2.8x0.8m, 1b,1vc, 200hp, 14kts, 9p; 1x1-381TT
	Samopal	2	76, 77	No23, 24	1878		30t, 25.6x3.3x1.9m, 1b,1vc, 250hp, 15kts, 8p; 1x1-381TT
	Shchuka	1	78	No83	1878		24t, 22.9x3.1x1.4m, 1b,1hda, 220hp, 16kts, 9p; 1x1-381TT

	Skumbriya	1	79	No87	1878		31t, 20.0x3.2x1.1m, 1b,1hda, 220hp, 13.5kts, 9p; 1x1-381TT
	Sirena	1	80	No16	1879		29t, 25.3x3.4x0.9m, 1b,1vc, 220hp, 14.5kts, 9p; 1x1-381TT
	Skorpion	1	81	No96	1879		31t, 19.2x3.1x1.2m, 1b,1hda, 220hp, 14kts, 9p; 1x1-381TT

SUBMARINES

SS	Delfin	1	1	Delfin	1904		113/136t, 19.6x3.6x3.0m, 1pe/em, 300/120hp, 9/7kts, 12p, 26m; 2-381TC
	Som	1	2	Som	1904		105/120t, 19.3x3.6x2.9m, 1pe/em, 160/70hp, 8.5/6kts, 18p, 30m; 1-450TT
SSX	Matros Pyotr Koshka	1	1	Matros Pyotr Koshka	1904		/20t, 15.2x1.3x1.1m, 6em, 24hp, 8.6/6kts, 3p, 20m; 2-381TT
	Forel	1	2	Forel	1904		17/18t, 12.5x1.7x1.1m, 1em, 65hp, 4.5/3.5kts, 4p, 10m; 2-381TT

OTHER FIGHTING SHIPS

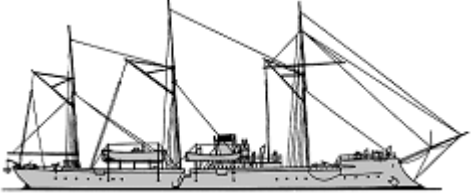
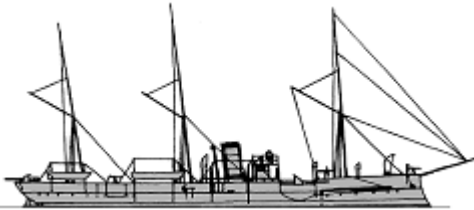
PG	Opyt	1	1	Mina	1862	No picture	270t, 37.7x6.8x1.8m, 1b,2hp, 195hp, 9kts, 28p; iron- 114breastwork; 2x1-87/17
	Yorsh	1	2	Yorsh	1875		321t, 30.1x8.7x2.2m, 2b,2hc, 240hp, 8kts, 44p; 4x1-87/21
	Burun	3	Burun	1880		424(3-5)-383(6)t, 36.4x8.8x2.4m, 2b,2hc, 240-283hp, 7.5kts, 54p; 1x1-279/18(5), 3x1-107/17(4), 6x1-107/17(6), 4x1-87/21(3), 5x1-87/21(4), 2x1-75/48(6), 3x1-37/20(3), 2x1-37/20(5,6)	
		4	Tucha	1880			
		5	Burya	1881			
		6	Groza	1881			
	Dozhd	7	Dozhd	1880		402(7)-390(8)t, 33.5x10.5(7)-11.6(8)x2.2m, 2b,2hc, 300(7)-445(8)hp, 9-9.3kts, 54p; 1x1-279/17(8), 6x1-37/20(7), 2x1-37/20(8)	
		8	Vikhr	1880			
	Koreets	1	9	Mandzhur	1887		1418t, 66.6x10.7x3.8m, 6b,2hc, 1500hp, 13kts, 179p; 2x1-203/33, 1x1-152/32, 4x1-107/17, 1x1-63/17, 2x1-47/40, 4x5-37/17, 1-381TT
	Kubanets	10	Kubanets	1887		1505t, 67.2(10-12)-64.5(13-15)x12.2x3.8m, 6b,2hc(11-12)-6b,2hte(13-15), 1500hp, 11-14kts, 180p; 2x1-203/33, 1x1-152/32, 6x5-47/22, 2-381TT	
		11	Terets	1887			
		12	Uralets	1888			
		13	Zaporozhets	1888			
		14	Chernomorets	1889			
	Grozyashchiy	16	Grozyashchiy	1892		1627(16)-1854(17)t, 72.3x12.7x4.0(16)-4.4(17)m, 6b,2vte, 2050(16)-2500(17)hp, 14-14.5kts, 178-188p; steel- 127belt, 38deck, 25CT; 1x1-229/32, 1x1-152/32, 6x1-47/40, 4x5-37/17, 2-381TT, 20mines	
		17	Otvazhny	1893			

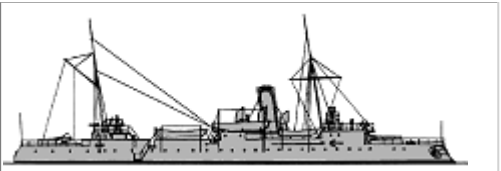
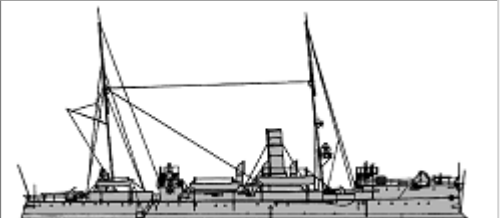
							
	Khrabry	1	18	Khrabry	1897		2100t, 72.3x12.7x3.8m, 8b, 2vte, 2100hp, 14kts, 188p; 2x1-203/43, 1x1-152/44, 5x1-47/40, 4x1-37/20, 1-450TT, 20mines

MINE WARFARE SHIPS

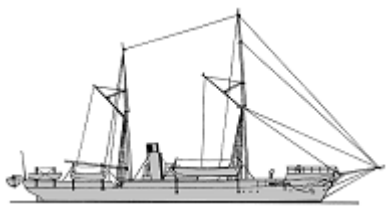
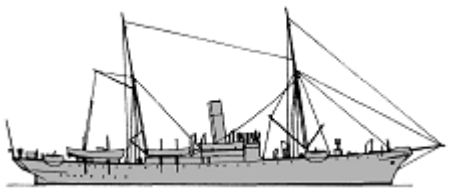
ML	Aleut	1	1	Aleut	1886		892t, 49.4x9.4x3.5m, 2b,1vc, 730hp, 11.9kts, 100p; 4x5-37/17, 250mines
	Bug	2	3	Bug Dunay	1892 1893		1490t, 62.2x10.4x4.6m, 4b,2vte, 1400hp, 13kts, 226p; 4x1-47/40, 545mines

BOARD GUARD SHIPS

CG	Roksana	1	1	Roksana	1893	No picture	157t, 37.0x4.2x2.0m, 2b,1vte, 600hp, 12kts; 2x5-37/17
	Oryol	1	2	Oryol	1898	No picture	125t, 35.1x5.2x2.4m, 250hp, 12kts, 28p; 2x1-37/20
	Kondor	2	3 4	Kondor Berkut	1902 1904	No picture	322t, 48.6x6.6x2.4m, 2vte, 1200hp, 13.5kts; 4x1-47/40, 2x1-37/20
CB	Strazh	2	1 2	Strazh Chasovoy	1874 1874	No picture	230t, 33.0x6.4x2.5m, 1vc, 300hp, 11kts, 36p; 1x1-87/17
	Yastreb	2	3, 4	Yastreb, Voron	1900	No picture	60t, 21.0x6.3x1.3m, 1vte, 150hp, 9kts; 1x1-76/14
	Korshun	1	5	Korshun	1900	No picture	100t, 30.5x6.1x1.5m, 1d, 225hp, 8kts, 36p; 2x1-37/20

[home](#)[World navies yesterday](#)[1905](#)

Sarawak 01 January 1905

OTHER FIGHTING SHIPS

PG	Aline	1	1	Aline	1875	No picture	175brt, 43.4x6.5m, 35hp; 2x1-small guns
	Lorna Doone	1	2	Lorna Doone	1881	No picture	118brt, 31.5x5.2m, 40hp, 2x1-small guns
	Aden	1	3	Aden	1884	No picture	300brt, 45.6x7.7m, (sw), 75hp; 1x1-small gun
	Kaka	1	4	Kaka	1901	No picture	400brt, (sw)

© Ivan Gogin, 2015

[home](#)[World navies yesterday](#)[1905](#)

Siam 01 January 1905

CRUISERS

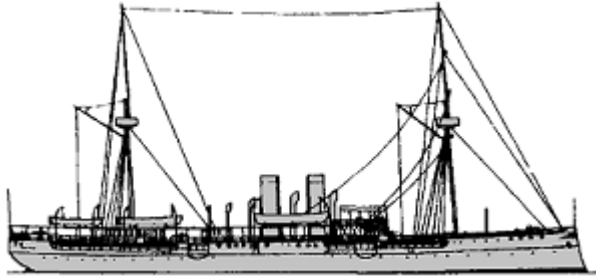
CL	Maha Chakri	1	1	Maha Chakri	1893		2500t, 88.4x12.0x4.2m, 5b,2vte, 3000hp, 15kts, 318p; steel- 51deck; 4x1-120/40, 10x1-57/40
----	-------------	---	---	-------------	------	--	--

TORPEDO SHIPS

TB	Moradoph	1	1	Moradoph	1888	No picture	45t, 22.0x2.8x1.5m, 1b,1hda, 35hp, 10kts; 1spar torpedo
----	----------	---	---	----------	------	------------	---

OTHER FIGHTING SHIPS

PG	Yong Yot	1	1	Yong Yot	1863	No picture	450t, 44.2x6.5x3.4m, 10kts; 6x1-134/14, 1x1-121/22
	Nirben	1	2	Nirben	1866	No picture	290t, 40.6x5.3x2.9m, 9kts; 1x1-102/14, 6x1-small guns
	Han Hak Sakru	1	3	Han Hak Sakru	1866	No picture	260t, 26.8x7.9x2.0m, 7kts; 1x1-102/27
	Maida	1	4	Maida	1867	No picture	370t, 41.8x5.9x3.1m, 11kts; 1x1-121/21
	Ranrukpahairi	1	5	Ranrukpahairi	1879	No picture	450t, 38.4x7.9x3.5m, 540hp, 11kts; 4x1-121/22, 1x1-57/27
	Mongkut Rajakumarn	1	6	Mongkut Rajakumarn	1887	No picture	700t, 53.3x7.2x3.4m, 2b,2vte, 800hp, 14kts, 100p; 2x1-120/40, 4x1-57/40, 3x1-37/20, 1-356TT
	Koh Si Chang	1	7	Koh Si Chang	1890	No picture	100t
	Udhai Rajakich	1	8	Udhai Rajakich	1890	No picture	134t
	Sathit Rajakarn	1	9	Sathit Rajakarn	1892	No picture	
	Theva Sooraram	1	10	Theva Sooraram	1898	No picture	115t
			11	Muratha	1898		530(11)-580(12,13)t, 44.2(11)-49.4(12,13)x7.0x3.1m, 2b,2vte, 500hp, 11.4kts, 83p; 1x1-120/40, 5x1-57/40, 4x1-37/20
		3	12	Bali	1900		
			13	Sugrib	1901		
FB	Siam Mongkut	1	1	Siam Mongkut	1870	No picture	950t, 64.0m; iron- 63battery; 8x1-102/21
DV	Prap Porapak	1	1	Prap Porapak	1898	No picture	210t

[home](#)[World navies yesterday](#)[1905](#)

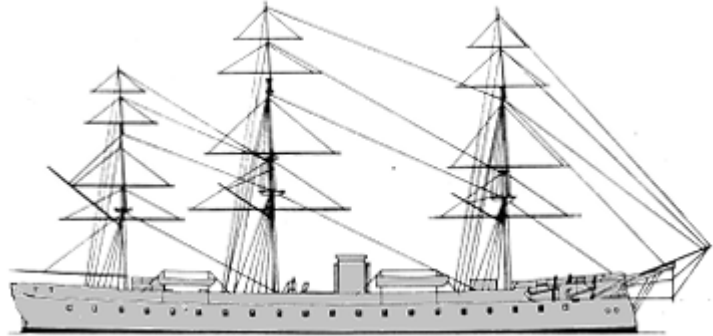
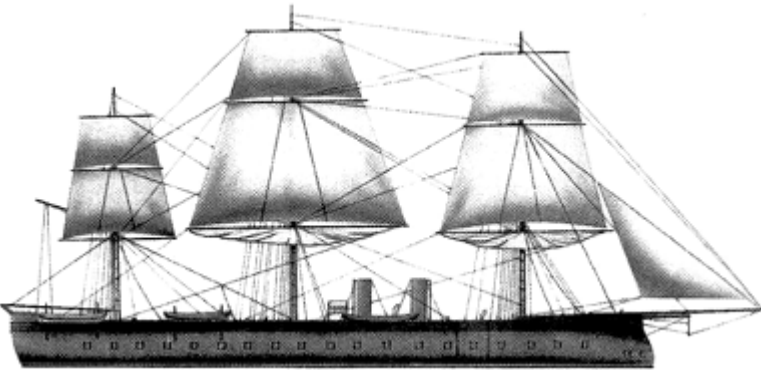
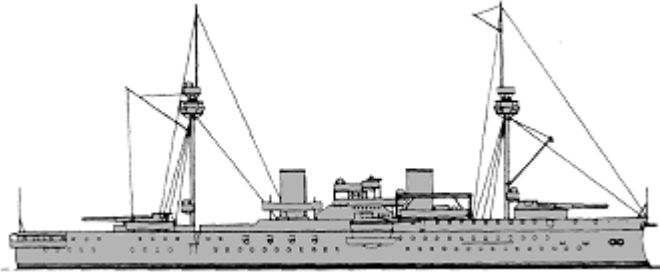

Spain 01 January 1905

BATTLESHIPS





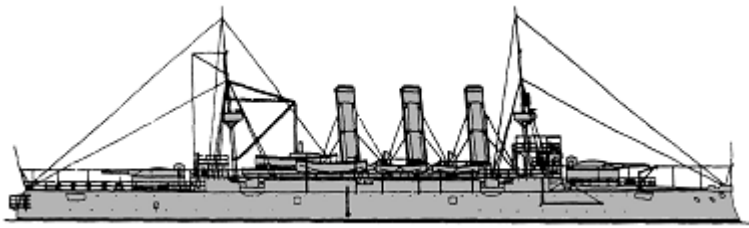
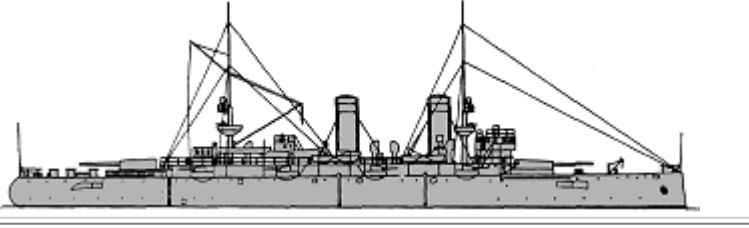
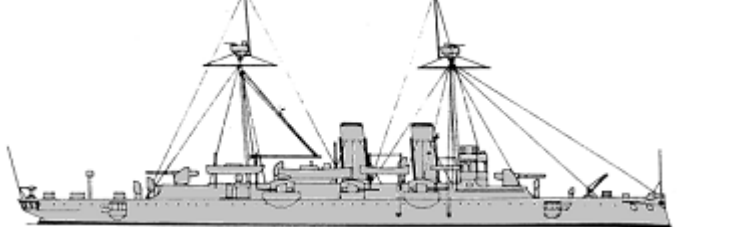
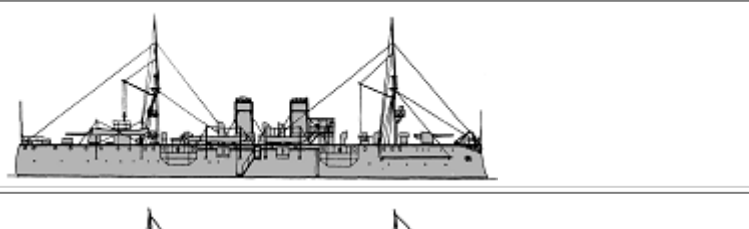
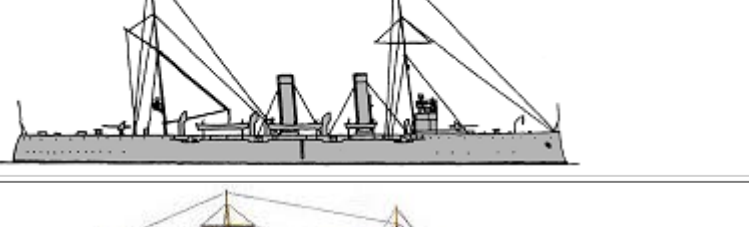

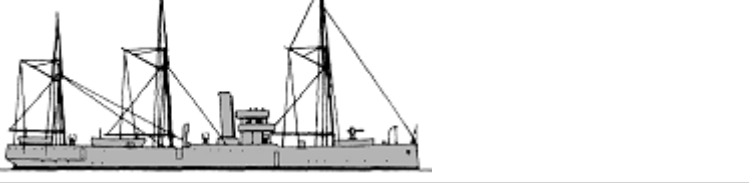

						7189t, 96.1x17.4x8.2m, 8b,1vc, 4500hp, 13kts, 500p; iron- 130belt, 120battery; 4x1-200/35, 3x1-150/48, 8x1-140/36, 12x1-47/40, 2-356TT
BB	Vitoria	1 2	Vitoria	1867		7135t, 96.4ppx17.4x8.1m, 8b,1hr, 4500hp, 12kts, 500p; iron- 130belt, 120battery; 4x1-200/35, 12x1-149/37, 8x1-57/42, 4x1-47/40, 4x1-37/27
	Pelayo	1 3	Pelayo	1888		9950t, 105.1x20.2x7.6m, 16b,2vc, 9473hp, 16kts, 520p; steel- 450belt, 70deck, 400barbettes, 155CT; 2x1-320/35, 2x1-280/35, 9x1-140/36, 5x1-57/42, 14x1-37/27, 3-381TT

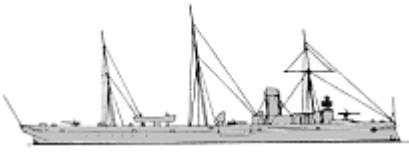
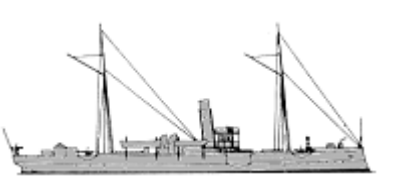
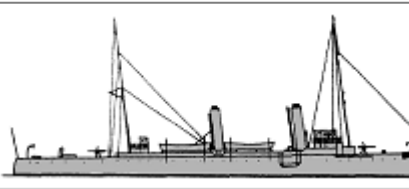
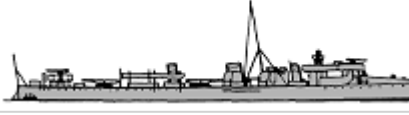
CRUISERS

	Carlos V	1 1	Carlos V	1897		10100t, 115.8x20.4x7.6m, 12b,2vte, 18500hp, 20kts, 583p; 50belt, 50deck, 250barbettes, 300CT;
--	----------	-----	----------	------	--	---

CA					2x1-280/35, 8x1-140/36, 4x1-57/42, 2x1-42/43, 4x1-37/27, 6-356TT	
Princesa de Asturias	2	Princesa de Asturias	1903		7549t, 111.0x18.6x6.6m, 6b,2hte, 14800hp, 20kts, 542p; Harvey- 300belt, 57deck, 100turrets, 200CT; 2x1-240/41, 8x1-140/33, 8x1-57/42, 10x1-37/27, 5-450TT	
	3	Cardenal Cisneros	1903			
	4	Cataluña	1904			
Reina Regente	1	Alfonso XIII	1896		4725t, 97.1x15.2x6.2m, 4b,2hte, 11500hp, 20.4kts, 440p; steel- 120deck, 75shields; 4x1-200/35, 6x1-120/35, 6x1-57/42, 6x1-37/27, 5-356TT	
	2	Lepanto	1899			
CL	1	3	Río de La Plata	1900		1950t, 76.3x10.8x4.4m, 2vte, 7100hp, 20kts, 213p; steel- 20slopes, 15deck, 120CT; 2x1-140/43, 4x1-100/56, 6x1-57/42, 2x1-37/27, 2-356TT
			Río de La Plata	1900		
	1	4	Extremadura	1902		2180t, 88.4x11.0x4.3m, 4b,2vte, 7000hp, 20kts, 246p; 50deck, 30CT; 8x1-101/50, 2x1-75/14, 4x1-57/42, 2x1-37/20
CLL	2	1	Aragón	1881		3289t, 71.9x13.4x7.2m, 4400hp, 14kts, 392p; 6x1-160/25(1), 4x1-149/32(2), 2x1-120/27(2), 2x1-87/22, 4x1-75/24, 2-356TT
		2	Navarra	1889		
	1	3	Infanta Isabel	1888		1152t, 67.4x9.8x3.9m, 4b,1hc, 1500hp, 13kts, 173p; 4x1-120/35, 4x5-37/17, 4x1-25/40, 2-356TT

TORPEDO SHIPS

PGT	Destructor	1	1	Destructor	1887		348t, 58.7x7.6x2.1m, 4b,2vte, 3784hp, 23kts, 45p; steel- 19belt, 19CT; 1x1-87/27, 4x1-57/42, 2x5-37/17, (3+1x2)-356TT
	Temerario	2		Temerario	1891		630t, 58.0ppx6.7x3.2m, 2b,2vte, 2600hp, 19kts, 91p; steel- 13deck; 2x1-120/35, 4x1-57/42, 1x4-25/42, 2x1-356TT
		3		Nueva España	1891		
		4		Marqués de Molins	1894		
		5		Martín Alonzo Pinzón	1893		
		6		Vicente Yáñez Pinzón	1894		
	María de Molina	7		María de Molina	1898		830t, 71.6ppx8.0x2.7m, 4b,2vte, 3500hp, 19.5kts, 91p; 152CT; 2x1-120/35, 4x1-42/42, (1+2x1)-356TT
		8		Marqués de la Victoria	1900		
		9		Álvaro de Bazán	1900		
DD	Furor	1	1	Terror	1896		450t, 67.1ppx6.7x1.7m, 4b,2vte, 6000hp, 28kts, 67p; 2x1-75/42, 2x1-57/42, 2x1-37/27, 2x1-356TT
	Audaz	2		Audaz	1898		430(2,3)-457(4)t, 69.8x6.9x1.8m, 4b,2vte, 7500hp, 30kts, 67p; 2x1-75/42, 2x1-57/42, 2x1-37/27, 2x1-356TT
		3		Osado	1898		
		4		Proserpina	1898		
TB	Acevedo	2	1, 2	Acevedo, Julián Ordóñez	1885		65t, 36.5x3.8x1.7m, 1b,1vc, 660hp, 20.5kts, 17p; 2x5-25/42, 2-356TT
	Orión	1	3	Orión	1886		88t, 38.0x4.8x2.0m, 1b,1vc, 1000hp, 21kts, 18p; 2x5-25/42, 2-356TT
	Barceló	2	4, 5	Barceló, Bustamante	1886-1887		65t, 38.0x3.1x2.2m, 1b,1vc, 800hp, 20kts, 17p; 2x1-47/40(8), 2x5-25/42(7), 2-356TT
	Habana	1	6	Habana	1887		67t, 38.9x3.8x1.6m, 1b,1vc, 730hp, 24.5kts, 17p; 1x5-25/42, 2-356TT
	Azor	7		Azor	1887		108t, 41.1x4.2x2.1m, 1b,1vc, 1300hp, 24kts, 23p; 3x1-42/42, 2-356TT
		8		Halcón	1887		
	Ariete	9		Ariete	1887		120t, 45.0x4.5x1.5m, 2b,2vc, 1300hp, 26.2kts, 18p; 2x1-42/42, 2x1-25/42, 2-356TT
10			Rayo	1887			
Vedette	3	11-13	No1-3	1892	No picture	18.3x2.8m, 1b,1vc, 18.3kts, 13p	

SUBMARINES

SS	Peral	1	1	Peral	1890	No picture	/87t, 21.3x2.6m, 2em, 60hp, /10kts, 6p, 50m; 1-356TT
----	-------	---	---	-------	------	------------	--

OTHER FIGHTING SHIPS

PG	General Concha	1	1	General Concha	1885	No picture	620t, 50.4x7.9x3.4m, 2b,2vc, 600hp, 11kts, 98p; 3x1-120/25, 2x4-25/42
	Mac-Mahón	1	2	Mac-Mahón	1888	No picture	115t, 27.6x4.9x1.8m, 2b,2vte, 150hp, 9kts, 15p; 2x1-42/42, 1x5-37/17
	Hernan Cortés	2	3	Hernan Cortés	1895	No picture	295t, 47.4x6.6x1.9m, 1b,1vte, 352hp, 13kts, 53p; 2x1-75/42, 2x1-57/42
			4	Vasco Núñez de Balboa	1895		
Ponce de Leon	1	5	Ponce de Leon	1896	No picture	200t, 41.4x5.8x1.8m, 2b,2vte, 230hp, 12kts, 38p; 2x1-57/42	
PR	Perla	1	1	Perla	1889	No picture	42t, 19.0x3.6x1.8m, 110hp, 7kts, 26p; 1x2-25/42

MINE WARFARE SHIPS



ML	Anteo	1	1	Anteo	1903	No picture	342t, 40.0x6.6x2.1m, 1b,1vte, 650hp, 11kts; 40mines, sweeps
----	-------	---	---	-------	------	------------	---

© Ivan Gogin, 2014

[home](#)[World navies yesterday](#)[1905](#)

Sweden 01 January 1905

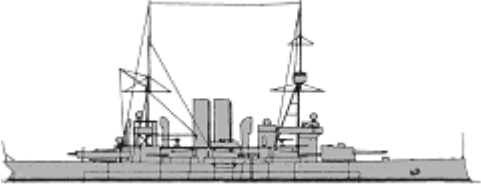
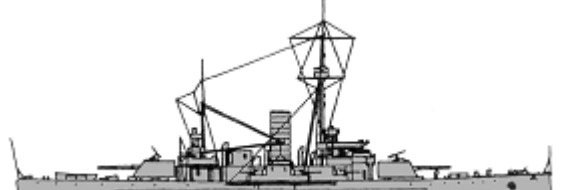
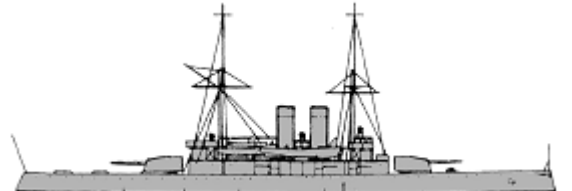
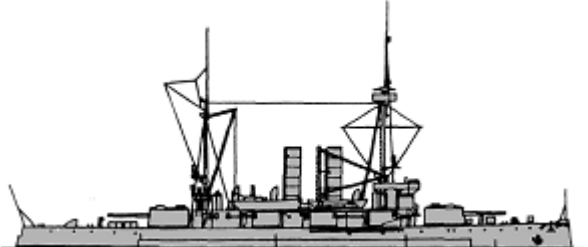









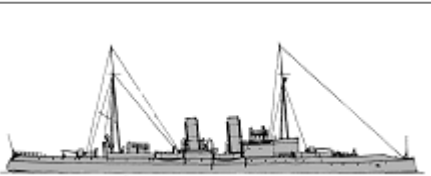

BATTLESHIPS

BC	Svea	1	Svea	1886		3273(1)-3300(2,3)t, 75.7(1)-78.8(2)-79.5(3)x14.8(1)-14.6(2,3)-5.1m, 6b,2vc, 3640(1)-4700(2,3)hp, 14.7(1)-16(2,3)kts, 252p; compound(1)-steel(2,3)- 297(1)-293(2,3)belt, 49deck, 190(KC)turret; 1x1-209/43, 7x1-152/43, 11x1-57/50	
		2	Göta	1891			
		3	Thule	1893			
	Oden	3	4	Oden	1897		3715(4)-3720(5,6)t, 86.3x14.8x5.3m, 6b,2vte, 5350hp, 16.5kts, 254p; steel(4)-Harvey(5,6)- 243(4)-240(5,6)belt, 49deck, 200(4)-190(5,6)turrets, 247(4)-190(5,6)CT; 2x1-254/41, 4x1-120/43(4), 6x1-120/43(5,6), 10x1-57/52, 2x2-25/32, 1-450TT
			5	Thor	1899		
			6	Njord	1899		
	Dristigheten	1	7	Dristigheten	1901		3600t, 89.0x14.8x4.9m, 8b,2vte, 5400hp, 16.5kts, 275p; Harvey- 200belt, 50deck, 200turrets, 247CT; 2x1-209/43, 6x1-152/43, 10x1-57/50, 2-450TT
	Äran	4	8	Äran	1902		3735t, 89.7x15.0x5.0m, 8b,2vte, 6500hp, 17kts, 275p; 175belt, 48deck, 190turrets, 200CT; 2x1-209/43, 6x1-152/43, 10x1-57/50, 2x1-37/34, 2-450TT
			9	Wasa	1902		
			10	Tapperheten	1903		
			11	Manligheten	1904		
MON	John Ericsson	1	John Ericsson	1865		1476t, 60.8x13.8x3.7m, 2b,1vde, 380hp, 7kts, 80p; iron- 125(1)-118(2,3)belt, 48(1)-25(2,3)deck, 270(1)-261(2,3)turret, 250(1)-237(2,3)CT; 1x2-274/16(2), 2x1-152/30(1), 1x2-120/43(3), 8x1-57/50(3), 2x1-57/46(1), 2x5-12/75(2)	
		2	Thordön	1866			
		3	Tirfing	1867			
Loke	1	4	Loke	1871		1574t, 64.0x14.0x3.6m, 2b,1vde, 430hp, 8.5kts, 80p; iron- 125belt, 25deck, 447turret, 237CT; 1x2-240/16	



CRUISERS

CL	Saga	1	1	Saga	1878	No picture	1617t, 61.0x10.2x5.6m, 1, 900hp, 11kts, 188p; 1x1-152/25, 8x1-122/20, 1x1-65/16
	Freja	1	2	Freja	1886	No picture	2000t, 66.0ppx12.0x5.7m, 1, 1750hp, 12kts, 284p; 4x1-152/25, 8x1-122/23, 2x1-65/16, 4x1-37/34

TORPEDO SHIPS

PGT	Örnen	5	1	Örnen	1897		844(1)-846(2)-835(3)-814(4)-800(5)t, 67.7(1-3)-70.7(4,5)x8.2(1-3)-8.3(4,5)x3.1(1-3)-3.0(4,5)m, 8b,2vte, 4000hp, 20kts, 113p; 2x1-120/43, 4x1-57/50, 1-381TT	
			2	Claes Horn	1898			
			3	Jacob Bagge	1898			
			4	Psilander	1900			
			5	Claes Uggla	1900			
DD	Mode	1	1	Mode	1902		453t, 67.1x6.2x2.7m, 4b,2vte, 6000hp, 30kts, 62p; 6x1-57/50, 2x1-450TT	
TB 1cl	Hugin	1	1	Hugin	1884		64t, 34.5x3.8x2.0m, 1b,1vc, 620hp, 18.5kts; 1x1-25/32, 2-381TT	
	Munin	3	2-4	Munin, Freke, Gere	1887		66t, 34.8x3.8x2.0m, 1b,1vc, 620hp, 18.5kts; 1x1-25/57, 2-381TT	
	Gondul	2	5, 6	Gondul, Gudur	1894		86t, 38.6x4.3x2.1m, 1b,1vc, 850hp, 19.5kts, 18p; 2x1-25/57, (1+1x1)-381TT	
	Komet	12	7	Komet	1896		120t, 39.8x4.8x2.5m, 1b,1vc, 1300hp, 23kts, 18p; 2x1-37/37, (1+1x1)-381TT	
			8	Blixt	1898			
			9	Meteor	1899			
			10	Stjerna	1899			
			11	Orkan	1900			
			12	Bris	1900			
			13	Vind	1900			
			14	Virgo	1902			
			15	Mira	1902			
			16	Orion	1903			
	17	Sirius	1903					
	18	Kapella	1904					
	TB2cl	Rolf	1	1	Blink	1882		38t, 27.9x3.6x1.9m, 1b,1vc, 350hp, 16kts; 1x1-25/32, 2-356TT
		Blixt	2	2, 3	Blixt, Galdr	1883-1885		43t, 30.5x3.6x1.9m, 1b,1vc, 420hp, 19kts; 1x1-25/32, 2-356TT
		Narf	2	4, 5	Narf, Nörve	1886		45t, 30.5x3.6x1.9m, 1b,1vc, 440hp, 19.5kts; 1x1-25/32, 2-356TT
Bygve		2	6, 7	Bygve, Bylgia	1887		57t, 31.5x3.6x1.9m, 1b,1vc, 460hp, 18.5kts; 1x1-25/58, 2-381TT	
Agne		2	8, 9	Agne, Agda	1891-1892		55t, 30.6x3.6x1.9m, 1b,1vc, 460hp, 18.9kts; 1x1-25/58, (1+1x1)-381TT	
N:o79		2	10,11	N:o79, 81	1903		55t, 31.7x3.6x1.9m, 1b,1vc, 700hp, 20.5kts; 1x1-37/37, (1+1x1)-381TT	
N:o83		2	12,13	N:o83, 85	1903		56t, 32.4x3.6x1.9m, 1b,1vc, 635hp, 20.8kts; 1x1-37/37, (1+1x1)-381TT	

OTHER FIGHTING SHIPS

MONL	Sköld	1	1	Sköld	1871		262t, 32.7x6.9x2.2m, 1b,1hc, 17hp, 3.7kts, 42p; iron- 25side, 229turret; 1x1-240/16, 2x1-12/75
	Gerda	2	2	Gerda	1872		459t, 39.7x8.0x2.5m, 2b,2hc, 133hp, 7.6kts, 42p; iron- 76belt, 418turret; 1x1-240/18, 2x1-25/32
			3	Hildur	1872		
	Ulf	5	4	Ulf	1873		460t, 39.8x8.0x2.5m, 2b,2hc, 155hp, 8kts, 42p; iron- 76belt, 418turret, 254CT; 1x1-120/44, 2x1-57/50
			5	Björn	1874		
			6	Berserk	1874		
			7	Sölve	1875		
			8	Folke	1875		
PG	Astrid	1	1	Alfhild	1863	No picture	204t, 32.0x6.3x2.2m, 1, 130hp, 9kts, 39p; iron- 20deck; 2x1-204/12
	Blenda	2	2	Blenda	1875	No picture	550t, 51.1x8.1x3.0m, 2b,2hc, 590hp, 11.5kts, 71p; 51CT(3); 1x1-274/17(2), 1x1-152/25(3), 1x1-122/23(2), 2x1-57/50(3)
			3	Disa	1877		
	Urd	6	4	Urd	1877	No picture	550t, 53.6x8.1x2.8m, 2b,2hc, 780hp, 72p; 51CT(4,6); 1x1-274/17(5,7-9), 1x1-152/30(4,6), 1x1-122/23(5,7-9), 1x1-120/43(4,6), 2x1-57/50(4,6,9), 2x1-25/32(5,7-9)
			5	Verdande	1880		
			6	Skagul	1878		
			7	Skuld	1881		
			8	Skäggard	1879		
	9	Rota	1878				
Edda	1	10	Edda	1885	No picture	640t, 55.8x8.3x3.1m, 2b,2vc, 960hp, 13.5kts, 76p; 1x1-274/23, 1x1-152/25, 2x1-25/32	
Svenskund	1	11	Svenskund	1891	No picture	280t, 38.5x7.9x3.0m, 440hp, 12.5kts; 2x1-57/50, mines	

MINE WARFARE SHIPS

ML	Ångkranpramen N:r3	1	1	Ångkranpramen N:r3	1879	No picture	190t, 6.5kts; mines
	Ångkranpramen N:r3	3	2	Ångkranpramen N:r5	1904	No picture	120t, 7.5kts; mines
			3	Ångkranpramen N:r6	1904		
			4	Ångkranpramen N:r7	1904		

[home](#)[World navies yesterday](#)[1905](#)

United Kingdom 01 January 1905

BATTLESHIPS

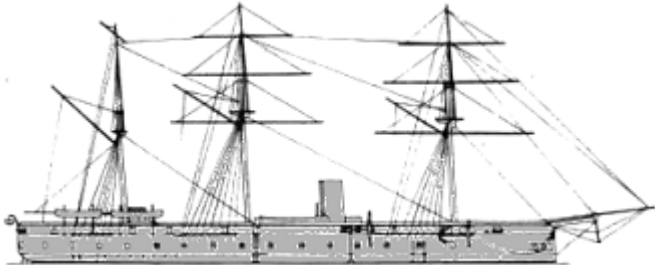
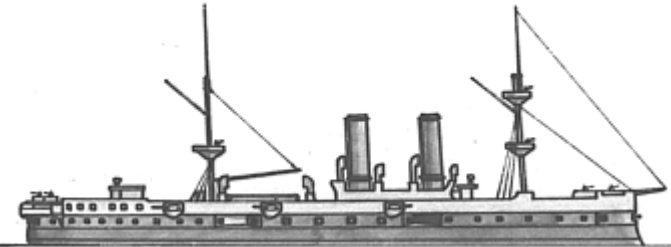
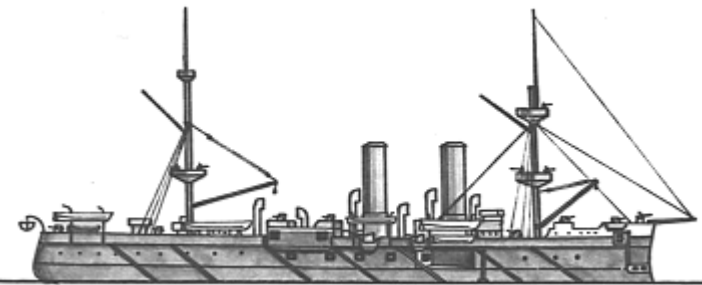
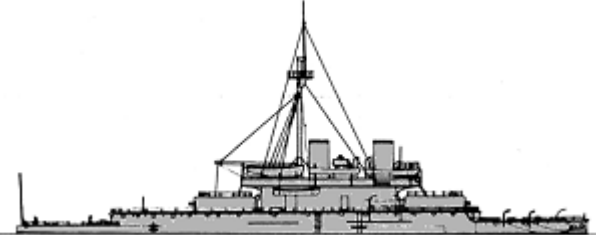
Hector	1	1	Hector	1864		6710t, 92.0x17.1x7.6m, 6b,1hr, 3260hp, 12.6kts, 530p; iron: 114belt, 114battery; 2x1-203/15MLR, 16x1-178/16MLR
Hercules	1	2	Hercules	1868		8830t, 99.1ppx18.0x7.7m, 8b,1ite, 8530hp, 15.9kts, 638p; iron: 229belt, 203battery; 8x1-254/15MLR, 2x1-229/14MLR, 3x1-178/16MLR, 2x1-152/40, 8x1-148/11, 6x1-120/40, 9x1-57/40, 13x1-47/40, 4-356TC
Sultan	1	3	Sultan	1871		9540t, 99.1ppx18.0x8.1m, 8b,1vte, 8244hp, 15.3kts, 633p; iron: 229belt, 229battery; 8x1-254/15MLR, 4x1-229/14MLR, 4x1-120/40, 7x1-95/21, 4x1-57/40, 4-356TC, 2 TBs
Devastation	2	4	Devastation	1873		9387-9390t, 93.6x19.0x8.0m, 8b,2vte, 7000hp, 14kts, 358p; iron: 305belt, 76deck, 356turrets, 229CT; 2x2-254/32, 6x1-57/40, 8x1-47/40, 8x1-25/60, 2-356TT
		5	Thunderer	1877		
Dreadnought	1	6	Dreadnought	1879		10886t, 104.6x19.5x8.1m, 12b,2vce, 8206hp, 14.5kts, 369p; iron: 356belt, 76deck,

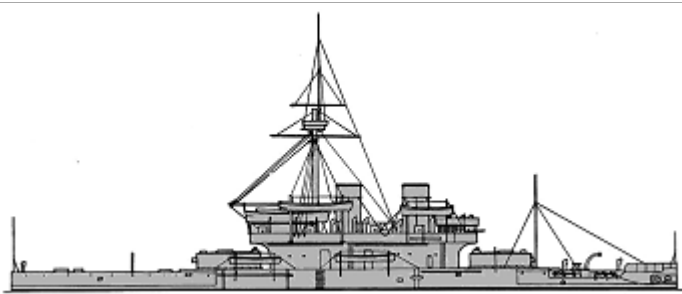
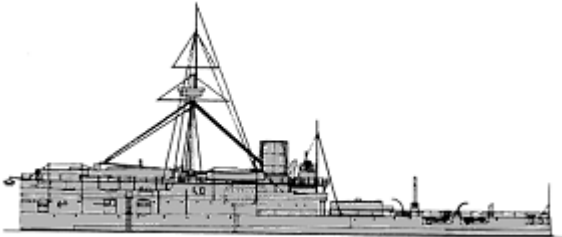
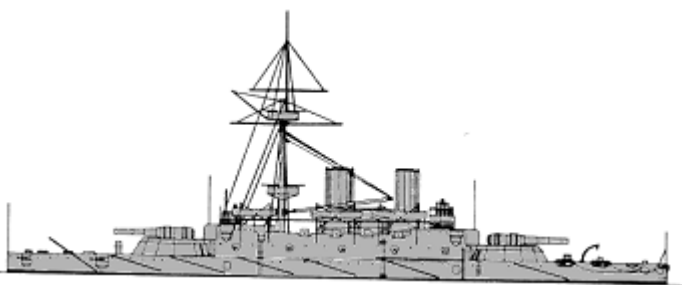
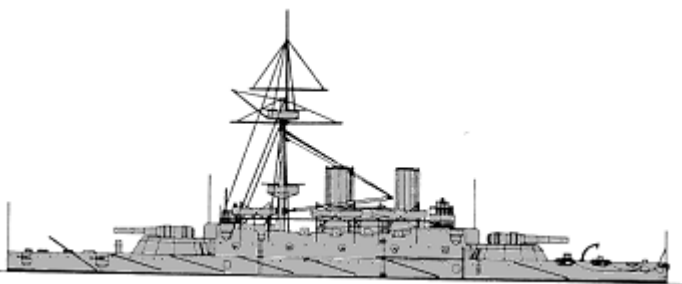
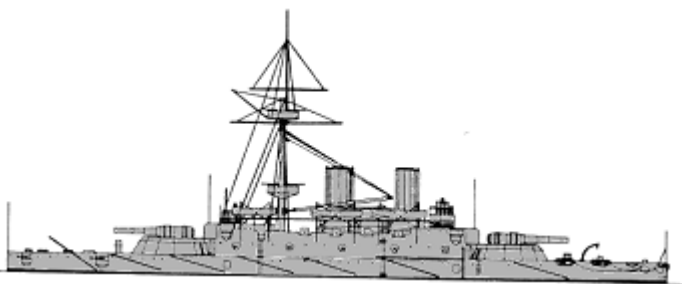
					356turrets, 356CT; 2x2-318/16MLR, 6x1-57/40, 10x1-47/40, 2-356TT
Conqueror	7	Conqueror	1886		6200-6440t, 87.8x17.7x7.2m, 8b,2ice, 6000hp, 15.5kts, 330p; compound: 305belt, 64deck, 356turret, 305CT; 1x2-305/25, 4x1-152/26, 7x1-57/40, 5x1-47/40, 6-356TC
	8	Hero	1888		
Collingwood	1 9	Collingwood	1887		9500t, 99.1ppx20.7x8.0m, 12b,2ice, 9600hp, 16.8kts, 498pp; compound: 457belt, 76deck, 229barbettes, 305CT: 2x2-305/25, 6x1-152/27, 12x1-57/40, 8x1-47/40, 4-356TT
Rodney	10	Rodney	1888		10300(10,11)-10600(12,13)t, 99.1pp(10,11)-100.6pp(12,13)x20.7(10,11)-20.9(12,13)x8.5m, 12b,3ice, 11500hp, 17(10,11)-17.4(12,13)kts, 530p; compound: 457belt, 76decks, 292(10,11)-356(12,13)barbettes, 305CT; 2x2-343/30, 6x1-152/27, 12x1-57/40, 10x1-47/40, 5-356TT
	11	Howe	1889		
	12	Camperdown	1889		
	4 13	Anson	1889		
Benbow	1 14	Benbow	1888		10600t, 100.6ppx20.9x8.5m, 12b,2ice, 10860hp, 17.5kts, 523p; compound: 457belt, 76deck, 356barbettes, 305CT; 2x1-413/30, 10x1-152/27, 12x1-157/40, 7x1-47/40, 5-356TT
Victoria	1 15	Sans Pareil	1891		10470t, 110.6x21.3x8.2m, 8b,2vte, 14482hp, 17.7kts, 430p; compound: 457belt, 76deck, 432turret, 356CT; 1x2-413/30, 1x1-254/32, 12x1-152/27, 12x1-57/40, 9x1-47/40, (4+2)-356TT/TC

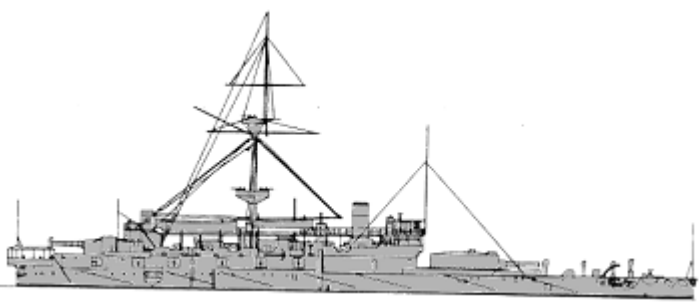
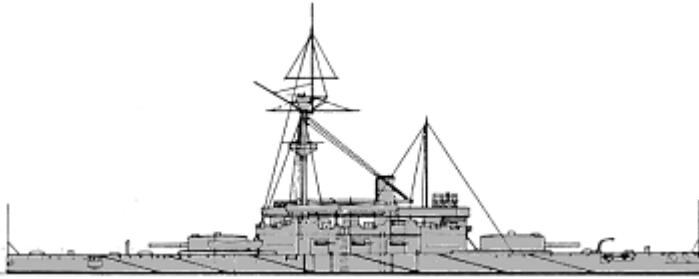
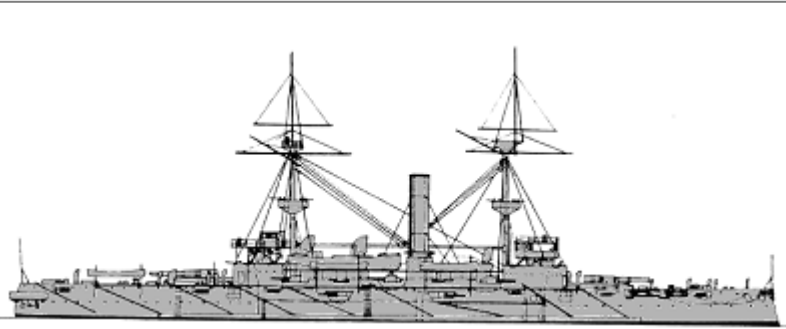
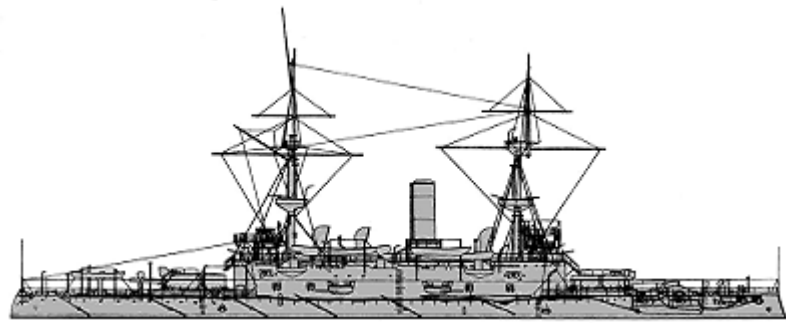
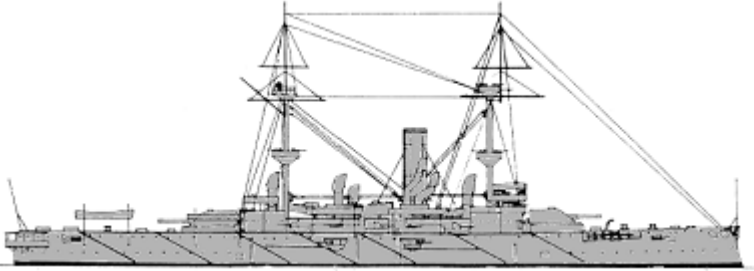

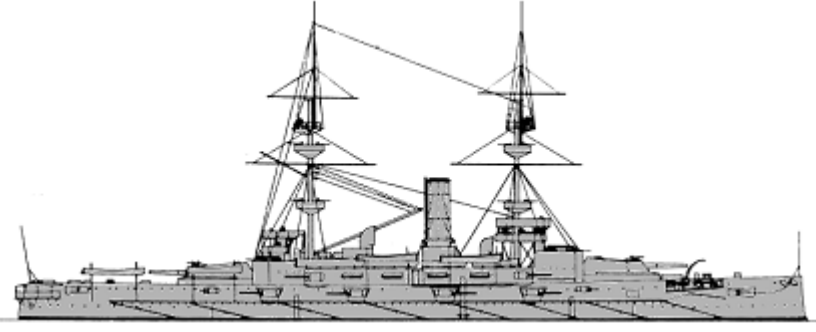
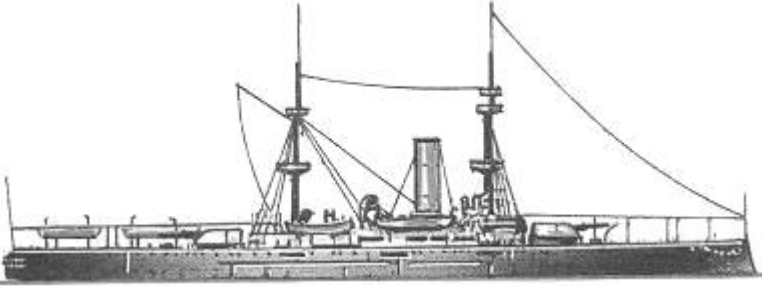
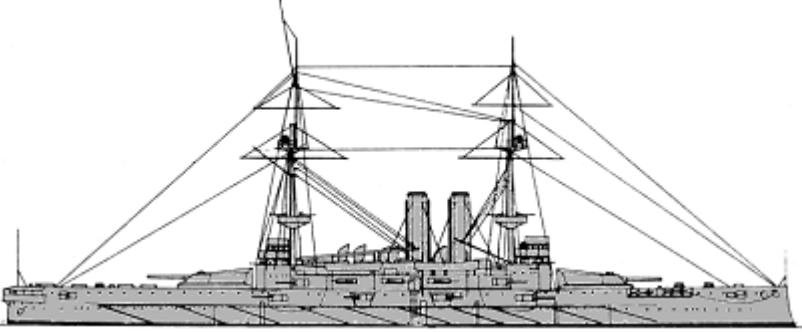
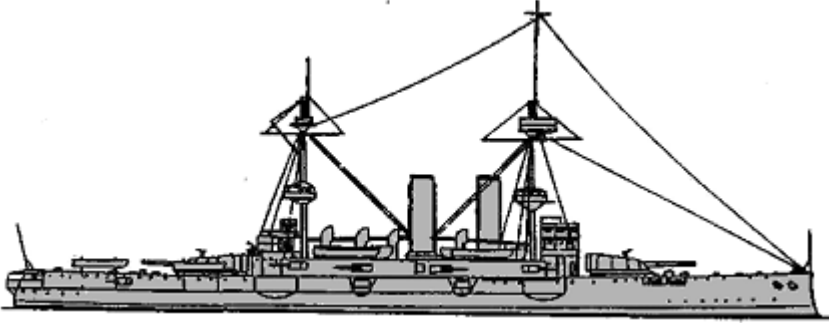
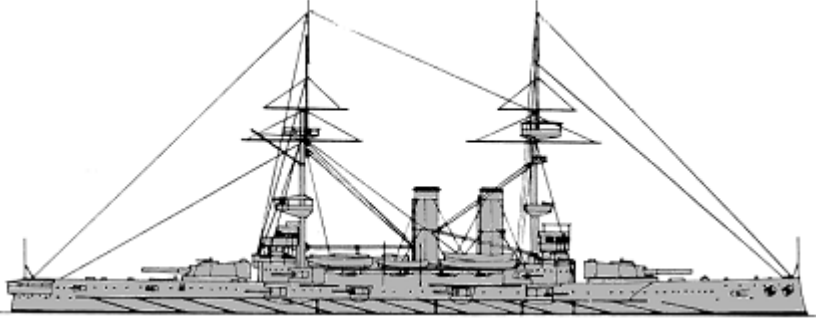
BB						
	Trafalgar	2	16 Trafalgar	1890		12590t, 105.2ppx22.3x8.7m, 6b,2vte, 12000hp, 16.7kts, 577p; compound: 508belt, 76deck, 457turret, 356CT; 2x2-343/30, 6x1-152/40, 8x1-57/40, 9x1-47/40, 4-356TT
			17 Nile	1891		
	Royal Sovereign	7	18 Royal Sovereign	1892		15580t, 125.0x22.9x8.4m, 8b,2vte, 11000hp, 16.5kts, 712p; compound: 457belt, 76deck, 432barbettes, 356CT; 2x2-343/30, 10x1-152/40, 16x1-57/40, 12x1-47/40, 7-450TT
			19 Empress of India	1893		
			20 Repulse	1894		
			21 Ramillies	1893		
			22 Resolution	1893		
			23 Revenge	1894		
	24 Royal Oak	1894				
Hood	1	25 Hood	1893		15590t, 125.0x22.9x8.3m, 8b,2vte, 11000hp, 16.7kts, 690p; compound: 457belt, 76deck, 432turrets, 356CT; 2x2-343/30, 10x1-152/40, 10x1-57/40, 12x1-47/40, 1-450TT	
Centurion	2	26 Centurion	1894		10500t, 109.7ppx21.3x7.8m, 8b,2vte, 13000hp, 18.5kts, 620p; compound: 305belt, 64(NS)deck, 152(Harvey) gun houses, 305CT; 2x2-254/32, 10x1-152/40, 8x1-57/40, 12x1-47/40, 2-450TT	
		27 Barfleur	1894			
		28 Magnificent	1895			
		29 Majestic	1895			
		30 Prince George	1896			

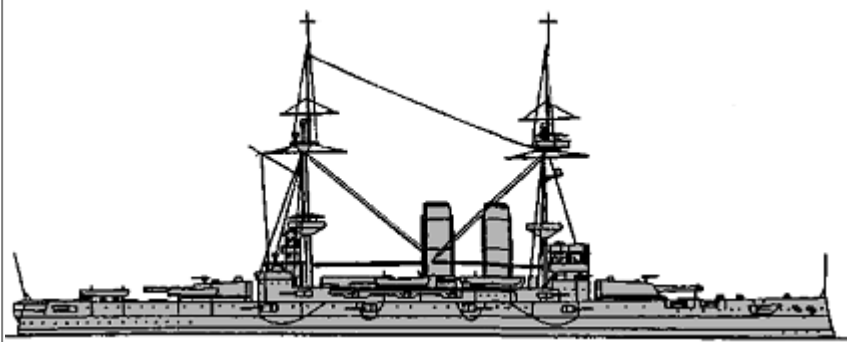
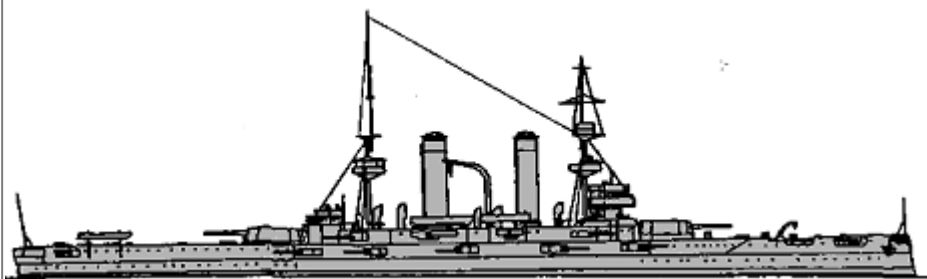
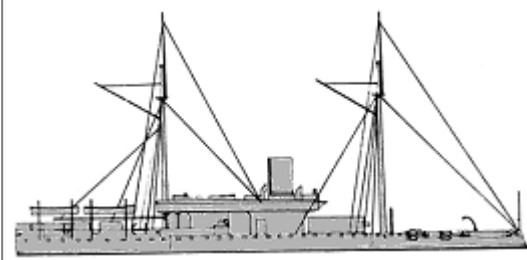
Majestic	9	31	Victorious	1896		15730-16060T, 128.3X22.9X8.2m, 8b,2vte, 12000hp, 17kts, 672p; Harvey: 229belt, 102deck, 254gunhouses, 356CT; 2x2-305/35, 12x1-152/40, 16x1-76/40, 12x1-47/40, 5-450TT
		32	Jupiter	1897		
		33	Mars	1897		
		34	Hannibal	1898		
		35	Caesar	1898		
		36	Illustrious	1898		
Renown	1	37	Renown	1897		12350t, 124.4x22.0x8.2m, 8b,2vte, 12000hp, 18kts, 674p; Harvey: 203belt, 76deck, 152gunhouses, 229CT; 2x2-254/32, 4x1-152/40, 12x1-76/40, 12x1-47/40, 5-450TT
Canopus	6	38	Canopus	1899		14300t, 128.5x22.6x8.0m, 20b,2vte, 13500hp, 18kts, 682p; Harvey: 152(Krupp)belt, 76deck, 203(38-42)-203(Krupp, 43)gunhouses, 305CT; 2x2-305/35, 12x1-152/40, 10x1-76/40, 6x1-47/40, 4-450TT
		39	Goliath	1900		
		40	Albion	1901		
		41	Ocean	1900		
		42	Glory	1900		
43	Vengeance	1902				
Formidable	3	44	Formidable	1901		15800t, 131.6x22.9x7.9m, 20b,2vte, 15000hp, 18kts, 780p; 229belt, 76decks, 254turrets, 356CT; 2x2-305/40, 12x1-152/45, 16x1-76/40, 6x1-47/40, 4-450TT
		45	Irresistible	1902		
		46	Implacable	1901		
London	5	47	London	1902		15700(47-49)-15400(50,51)t, 131.6x22.9x7.9m, 20b,2vte, 15000hp, 18kts, 714p; 229belt, 64decks, 254turrets, 356CT; 2x2-305/40, 12x1-152/45, 16x1-76/40, 6x1-47/40, 4-450TT
		48	Bulwark	1902		
		49	Venerable	1902		
		50	Queen	1904		
		51	Prince of Wales	1904		



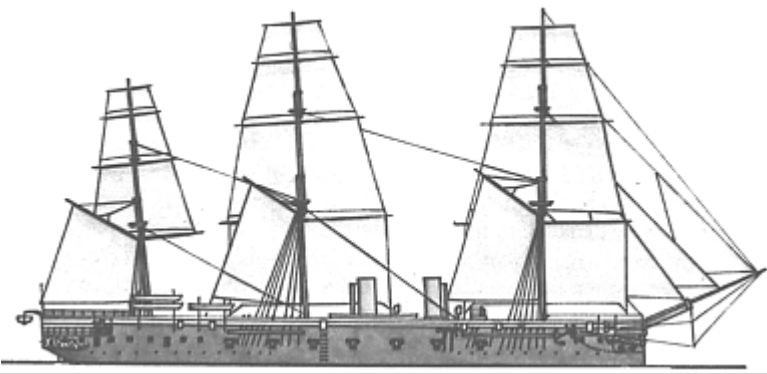
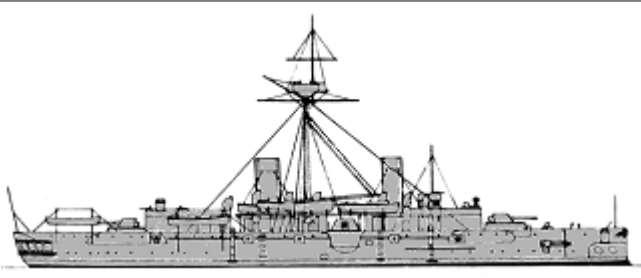

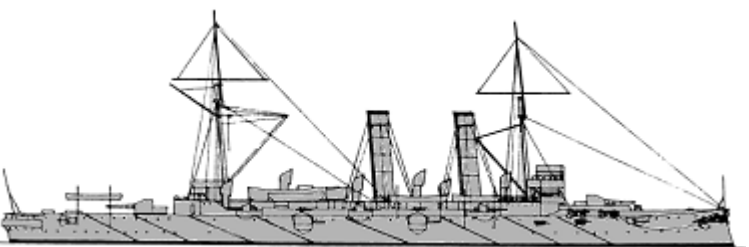
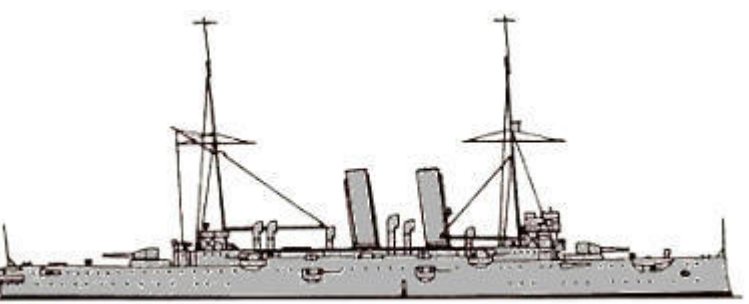
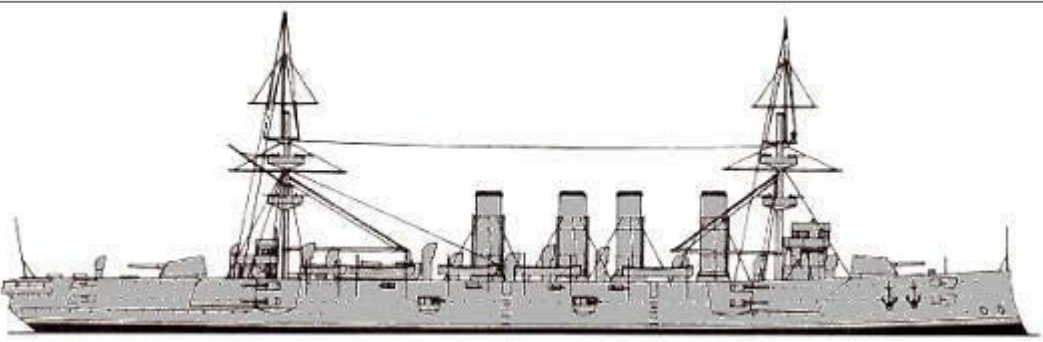
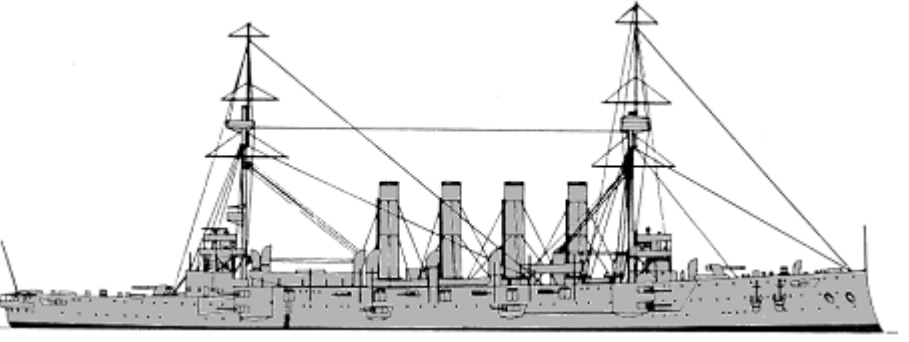
Duncan	6	52	Russell	1903		14900-15200t, 131.7x23.0x7.9m, 24b,2vte, 18000hp, 19kts, 720p; 178belt, 51decks, 254turrets, 305CT; 2x2-305/40, 12x1-152/45, 10x1-76/40, 6x1-47/40, 4-450TT
		53	Albermarle	1903		
		54	Montagu	1903		
		55	Duncan	1903		
		56	Cornwallis	1904		
		57	Exmouth	1903		
Swiftsure	2	58	Swiftsure	1904		11800(58)-11985(59)t, 146.2x21.6x7.7m. 12b,2vte, 12500hp, 19kts, 800p; 178belt, 76decks, 254turrets, 279CT; 2x2-254/45, 14x1-190/50, 14x1-76/50, 6x1-57/50, 2-450TT
		59	Triumph	1904		
BC Rupert	1	1	Rupert	1874		5440t, 80.5ppx16.2x6.9m, 2hse, 4630hp, 13.6kts, 217p; iron: 279belt, 76deck, 356turret, 305CT; 1x2-234/32, 2x1-152/26, 4x1-57/40, 6x1-47/40, 8x1-11.4, 4-356TT

CRUISERS

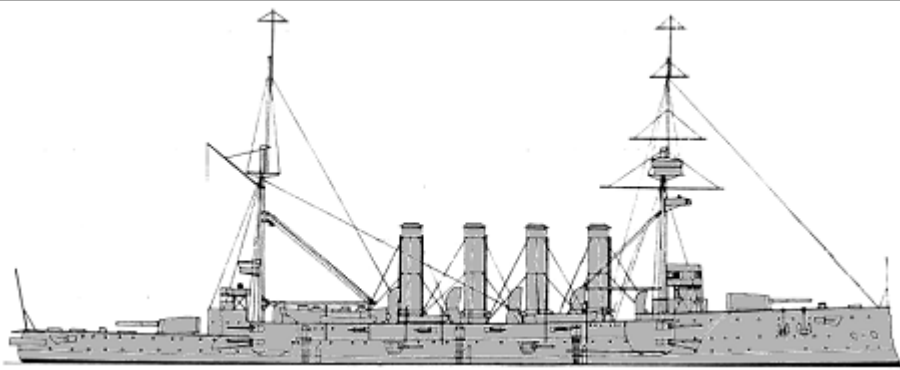
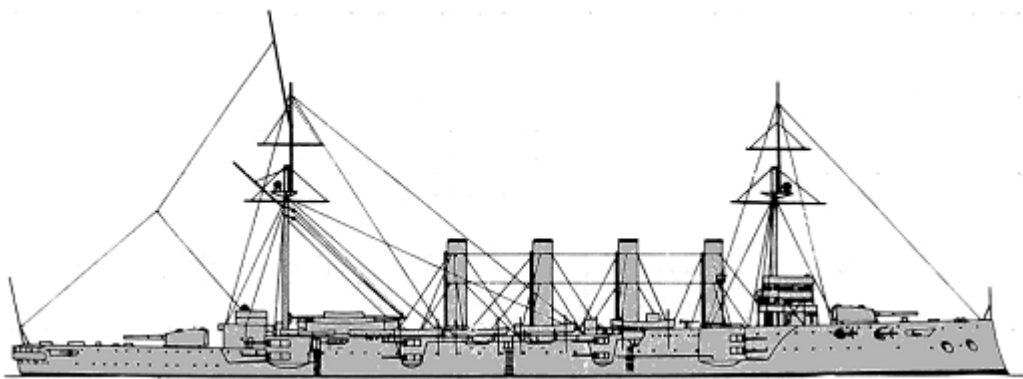
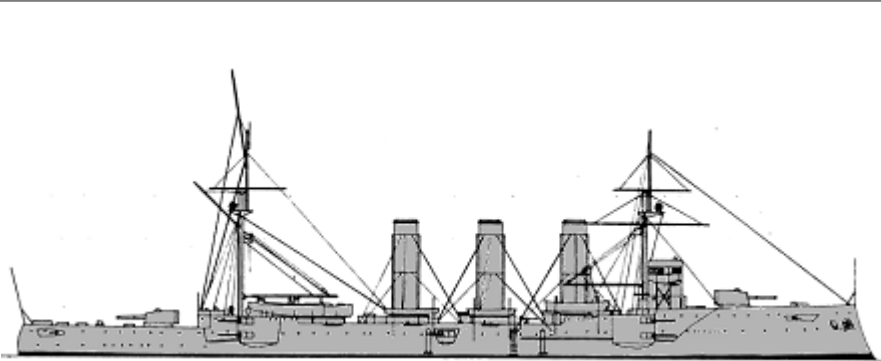
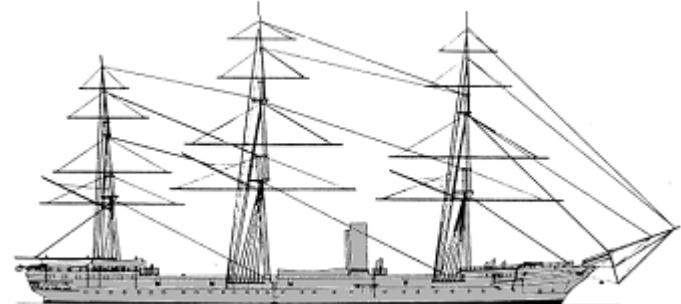

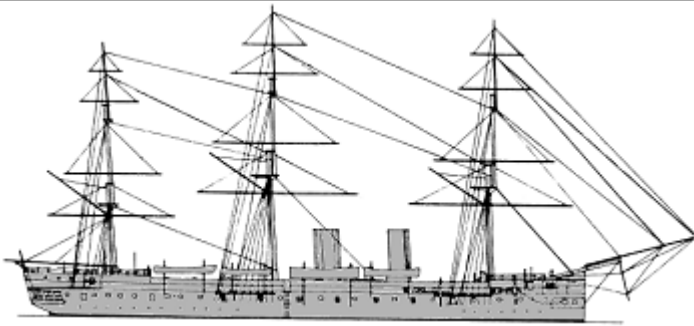
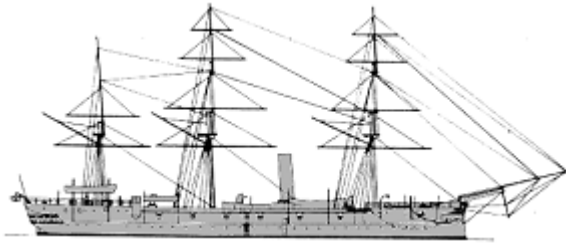
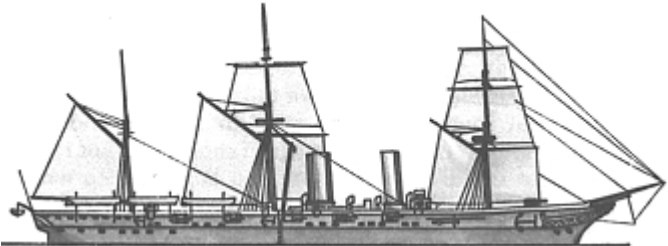
Raleigh	1	1	Raleigh	1874		5200t, 90.8ppx14.9x7.5m, 9b,1hse, 5639hp, 15.3kts, 530p; 2x1-229/14MLR, 6x1-178/16MLR, 6x1-160/16MLR, 8x1-152/26, 8x1-127/25, 4x1-76/20, 12x6-11.4, 2-356TC
Imperieuse	2	2	Imperieuse	1886		8500t, 96.0ppx18.9x8.2m, 12b,3ice, 10000hp, 16.7kts, 555p; compound: 254belt, 102deck, 203barbettes, 229CT; 4x1-234/32, 8x1-152/27, 4x1-57/40, 6-450TT
		3	Warspite	1888		
		4	Orlando	1888		

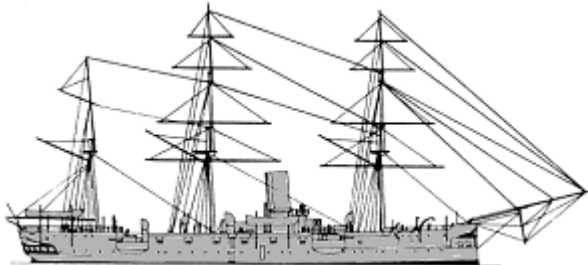

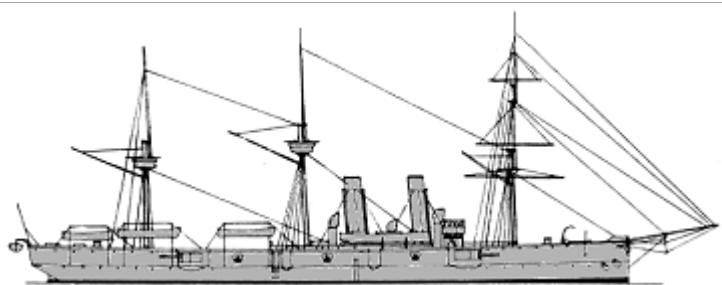
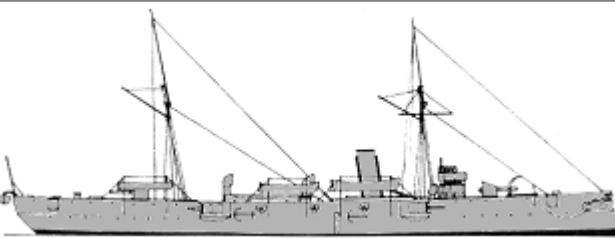
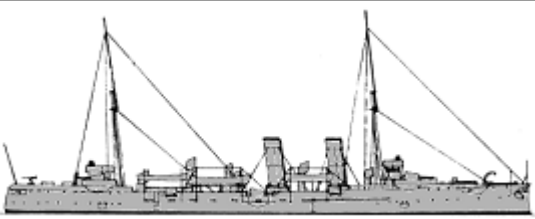
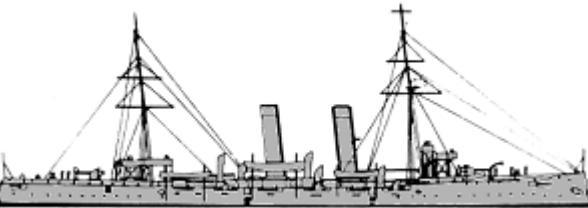

CA	Orlando	7	5	Australia	1888		5600t, 91.4ppx17.1x6.9m, 4b,2vte, 8500hp, 18kts, 484p; compound: 254belt, 76deck, 305CT; 2x1-234/32, 10x1-152/27, 6x1-57/40, 10x1-47/40, 6-450TT
			6	Undaunted	1889		
			7	Narcissus	1889		
			8	Galatea	1889		
			9	Immortalité	1889		
			10	Aurora	1889		
	Blake	2	11	Blake	1892		9150t, 121.8x19.8x7.3m, 6b,2vte, 20000hp, 21.4kts, 570p; compound: 152deck, 114shields, 305CT; 2x1-234/32, 10x1-152/40, 16x1-47/40, 4-356TT
			12	Blenheim	1894		
	Edgar	9	13	Edgar	1893		7350(13,15-17,21)-7700(14,18-20)t, 118.1x18.3x7.2m, 5b,2vite, 12000hp, 20kts, 544p; steel: 127deck, 152casemates, 305CT; 2x1-234/32(13,15-17,19-21), 1x1-234/32(14,18), 10x1-152/40(13,15-17,19-21), 12x1-152/40(14,18), 12x1-57/40, 5x1-47/40, 4-450TT
			14	Royal Arthur	1893		
			15	Hawke	1893		
			16	Endymion	1894		
			17	Grafton	1894		
			18	Crescent	1894		
			19	Gibraltar	1894		
			20	St. George	1894		
	Powerful	2	22	Terrible	1898		14200t, 164.0x21.6x7.3m, 48b,2vte, 25000hp, 22kts, 894p; Harvey: 152deck, 152turrets, 305CT; 2x1-234/41, 16x1-152/40, 14x1-76/40, 12x1-47/40, 4-450TT
			23	Powerful	1897		
	Diadem	4	26	Diadem	1898		11000t, 141.0x21.0x7.8m, 30b,2vte, 16500(26-29)-18000(30-33)hp, 20.2(26-29)-20.7(30-33)kts, 677p; Harvey: 102deck, 114casemates, 305CT; 16x1-152/40, 14x1-76/40, 3x1-47/40, 3-450TT
			27	Niobe	1898		
			28	Europa	1899		
			29	Andromeda	1899		
			30	Amphitrite	1901		
			31	Argonaut	1900		
			32	Ariadne	1902		
			34	Sutlej	1902		
			35	Cressy	1901		
			36	Aboukir	1902		

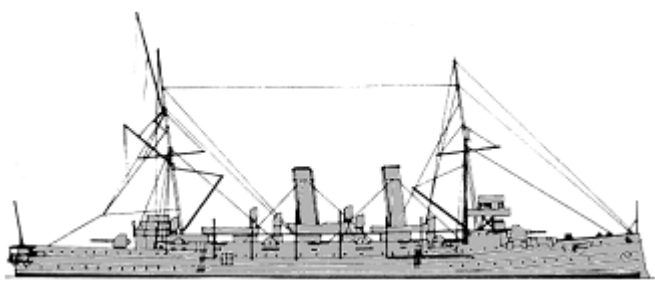
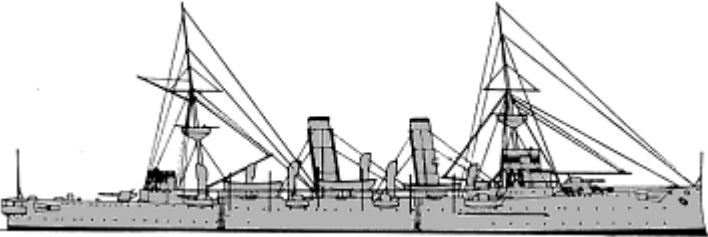
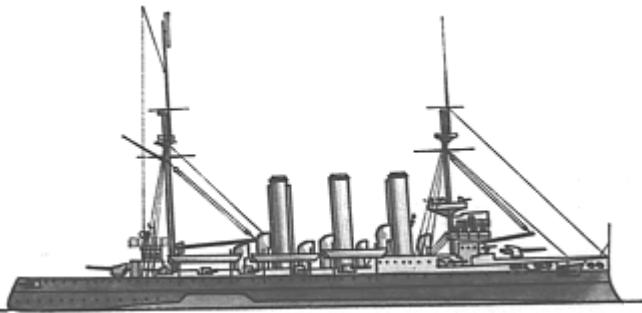
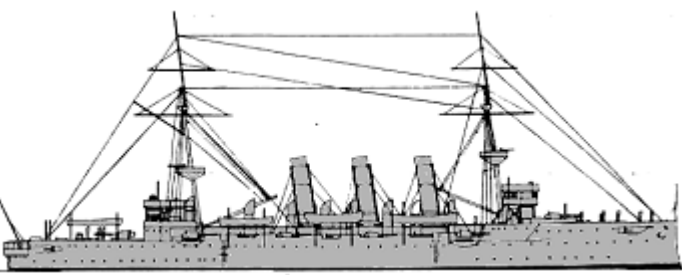
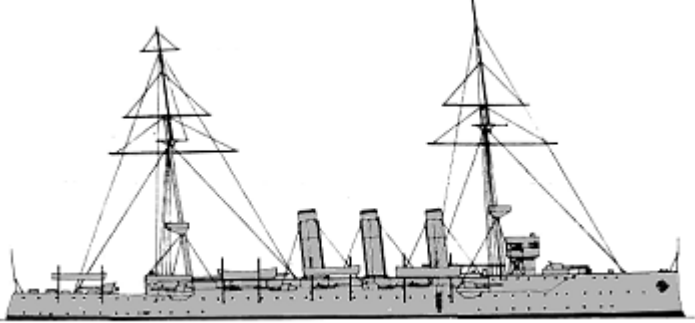

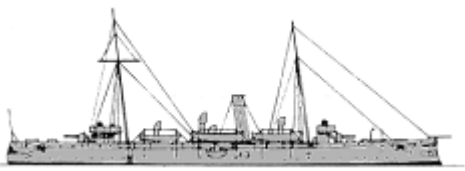

Cressy	6					<p>12000t, 143.9x21.2x7.9m, 30b,2vte, 21000hp, 21kts, 760p; 152belt, 76deck, 152turrets, 305CT; 2x1-234/47, 12x1-152/45, 12x1-76/40, 3x1-47/40, 2-450TT</p>
		37	Hogue	1902		
		38	Bacchante	1902		
		39	Euryalus	1904		
Drake	4	40	Good Hope	1902		<p>14150t, 162.6x21.7x7.9m, 43b,2vte, 30000hp, 23kts, 900p; 152belt, 64deck, 152turrets, 305CT; 2x1-234/47, 16x1-152/45, 14x1-76/40, 3x1-47/40, 2-450TT</p>
		41	Drake	1903		
		42	Leviathan	1903		
		43	King Alfred	1903		
Monmouth	10	44	Kent	1903		<p>9800t, 141.3x20.1x7.6m, 31b,2vte, 22000hp, 23kts, 678p; 102belt, 51deck, 127turrets, 254CT; (2x2+10x1)-152/45, 10x1-76/40, 3x1-47/40, 2-450TT</p>
		45	Essex	1904		
		46	Bedford	1903		
		47	Monmouth	1903		
		48	Donegal	1903		
		49	Berwick	1903		
		50	Cornwall	1904		
		51	Cumberland	1904		
		52	Lancaster	1904		
53	Suffolk	1904				
Volage	1	1	Active	1871		<p>3078t, 82.3ppx12.8x6.7m, 5b,1hrccr, 4130hp, 15kts, 340p; 2x1-160/16MLR, 10x1-152/26, 2x1-76/20, 9x6-11.4, 2-356TC</p>
Bacchante	1	2	Boadicea	1877		<p>3913t, 85.3ppx13.7x7.2m, 10b,1hcrcr, 5134t, 14.8kts, 375p; 14x1-178/14MLR, 2x1-160/16MLR, 2x1-152/26, 7x1-76/20, 10x6-11.4, 2-356TC</p>

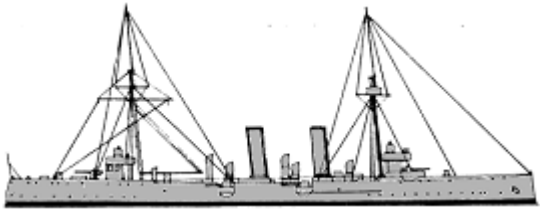
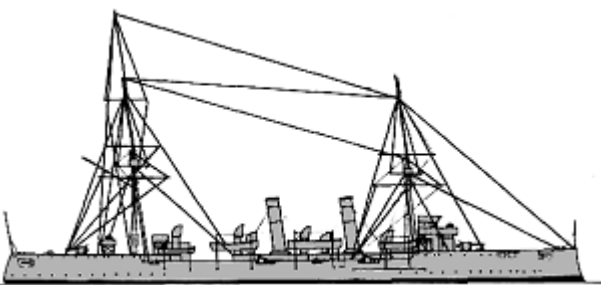
						
Comus	1	3	Cleopatra	1880		2380t, 68.6ppx13.6x5.9m, 6b,1hce, 2610hp, 13kts, 265p; steel: 13deck; 4x1-152/26, 8x1-127/25, 2x1-76/19, 4x1-47/40, 2-356TC
Iris	2	4	Iris	1879		3730t, 101.5(4)-96.0(5)x14.0x6.7m, 12b,2hdace, 6000hp, 17.5kts, 275p; 13x1-127/25, 4x1-47/40, 4-356TC
		5	Mercury	1879		
Satellite	2	6	Rapid	1884		1420t, 61.0ppx11.6x4.8m, 8b,1hce, 1400-1640hp, 13-13.1kts, 175-200p; steel: 25deck; 1x1-152/26(6), 10x1-127/25(6), 14x1-127/25(7), 4x1-11.4(6), 8x1-11.4(7)
		7	Pylades	1886		
Calypso	1	8	Calliope	1887		2770t, 71.6ppx13.6x6.1m, 6b,1hce, 3000hp, 13.7kts, 317p; steel: 13deck; 4x1-152/26, 12x1-127/25, 2x1-76/19, 10x1-11.4, 2-356TC
Leander	3	9	Arethusa	1887		4300t, 96.0x14.0x6.3m, 12b,2hdace, 5500hp, 16.5kts, 278p; steel: 38deck, 38shields; 10x1-152/26, 4x1-47/40(10,11), 8x1-47/40(9), 6x4-25/40(10,11), 2x4-25/40(9), 2x6-11.4, 4x5-11.4, 4-356TC
		10	Phaeton	1886		
		11	Amphion	1886		

CL							
	Mersey	2	12	Mersey	1887		4050t, 96.0x14.0x5.9m, 12b,2hdace, 6000hp, 18kts, 325p; steel: 76deck, 51shields, 229CT; 2x1-203/30, 10x1-152/26, 3x1-57/40, 3x1-47/40, 9x1-11.4, (2+2)-356TT/TC
			13	Severn	1888		
	Medea	5	14	Magicienne	1889		2950(14,17,18)-2800(15,16)t, 80.8ppx12.8(14,17,18)-12.5(15,16)x5.0m, 6b,2hdace(14,17,18)-6b,2vce(15,16), 9000hp, 19.7(14,17,18)-20(15,16)kts, 218p; steel: 51deck, 114shields, 76CT; 6x1-152/26, 9x1-57/40, 1x1-47/40, 3x1-11.4, (2+2)-356TT/TC
			15	Medea	1889		
			16	Medusa	1889		
			17	Marathon	1889		
			18	Melpomene	1889		
	Apollo	20	19	Latona	1891		3400(19-28)-3600(29-38), 95.7x13.1(19-28)-13.3(29-38)x5.3(19-28)-5.6(29-38), 5b,2vte, 9000hp, 20(19-28)-19.7(29-38), 273p; steel: 51deck, 114shields, 76CT; 2x1-152/40, 6x1-120/40, 8x1-57/40, 1x1-47/40, 4x1-11.4, 4-356TT
			20	Melampus	1891		
			21	Andromache	1891		
			22	Terpsichore	1892		
			23	Naiad	1892		
			24	Thetis	1892		
			25	Apollo	1892		
26			Tribune	1892			
27			Sappho	1893			
28			Scylla	1893			
29			Sirius	1892			
30			Pique	1893			
31			Spartan	1892			
32	Indefatigable	1892					
33	Rainbow	1893					
34	Intrepid	1892					
35	Brilliant	1893					
36	Retribution	1893					
37	Aeolus	1894					
38	Iphigenia	1893					
		39	Bonaventure	1894			
		40	Cambrian	1894			
		41	Astraea	1895			

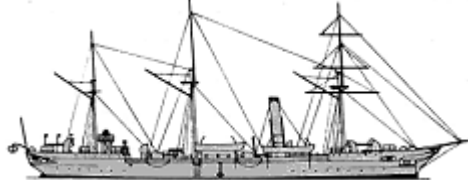
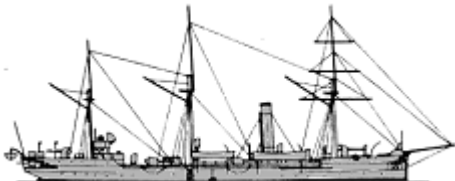

Astraea	8					4360t, 103.5x15.1x5.8m, 8b,2vte, 9500hp, 19.5kts, 318p; steel: 51deck, 114shields, 76CT; 2x1-152/40, 8x1-120/40, 10x1-57/40, 1x1-47/40, 4-450TT
		42	Charybdis	1896		
		43	Fox	1896		
		44	Hermione	1896		
		45	Flora	1895		
		46	Forte	1895		
Eclipse	9	47	Eclipse	1897		5600t, 113.7x16.3x6.3m, 8b,2vte, 9600hp, 19.5kts, 450p; Harvey: 76deck, 76shields, 152CT; 5x1-152/40(47), 11x1-152/45(48-55), 6x1-120/40(47), 8x1-76/40, 6x1-47/40, 2x1-11.4, 3-450TT
		48	Talbot	1896		
		49	Venus	1897		
		50	Minerva	1897		
		51	Juno	1897		
		52	Diana	1897		
		53	Doris	1897		
		54	Dido	1898		
		55	Isis	1898		
Arrogant	4	56	Arrogant	1898		5750t, 104.2x17.5x6.1m, 18b,2vte, 10000hp, 19kts, 480p; Harvey: 76deck, 114shields, 229CT; 10x1-152/45, 8x1-76/40, 3x1-47/40, 5x1-11.4, 3-450TT
		57	Furious	1898		
		58	Gladiator	1899		
		59	Vindictive	1900		
Highflyer	3	60	Hermes	1899		5650t, 113.4x16.5x6.3m, 18b,2vte, 10000hp, 20kts, 450p; Harvey: 76deck, 76shields, 152CT; 11x1-152/40, 9x1-76/40, 6x1-47/40, 2-450TT
		61	Highflyer	1899		
		62	Hyacinth	1900		
Challenger	1	63	Challenger	1904		5880t, 113.4x16.5x6.3m, 18b,2vte, 12500hp, 21kts, 450p; 76deck, 76shields, 152CT; 11x1-152/45, 9x1-76/40, 6x1-47/40, 2-450TT
		1	Barrosa	1890		1580t, 71.0x10.7x4.6m, 4b,2vte, 160p; steel: 51deck, 51shields; 6x1-
		2	Barracouta	1891		

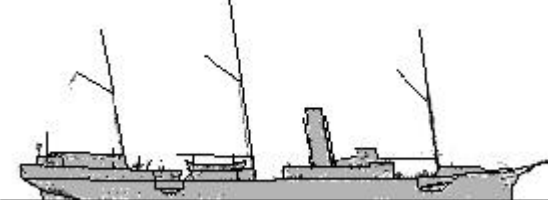

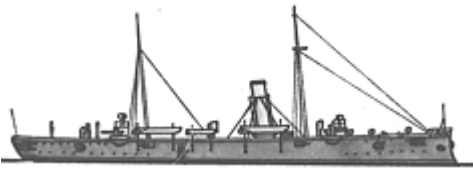
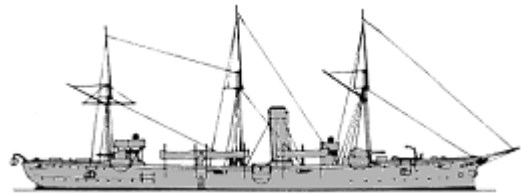



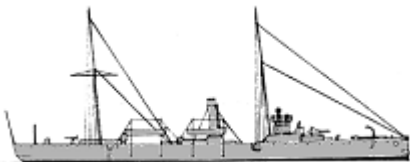

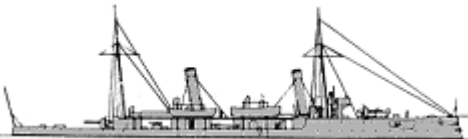

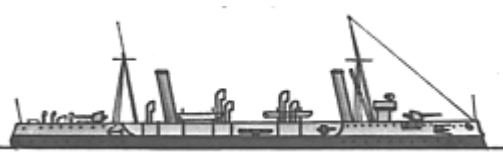
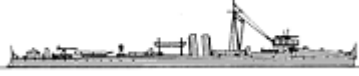

CLL	Barracouta	4				120/40, 4x1-47/40, 2x1-11.4, 2-356TT	
			3	Blanche			1891
				4	Blonde	1891	
	Barham	2	5	Barham	1891		1830t, 85.3ppx10.7x4.0m, 6b,2vte, 4700hp, 18kts, 169p; steel: 51deck, 51shields; 6x1-120/40, 4x1-47/40, 2x1-11.4, 2-356TT
			6	Bellona	1891		
	Pearl	9	7	Katoomba	1891		2575t, 84.7x12.5x4.7m, 4b,2vte, 7500hp, 19kts, 217p; steel: 51deck, 51shields, 76CT; 8x1-120/40, 8x1-47/40, 4x1-11.4, (2+2)-356TT/TC
			8	Tauranga	1891		
			9	Mildura	1891		
			10	Ringarooma	1891		
			11	Wallaroo	1891		
			12	Pallas	1891		
13			Phoebe	1892			
14			Pearl	1892			
15			Philomel	1891			
Pelorus	11	16	Proserpine	1899		2135-2200t, 95.6x11.1x4.9m, 16b,2vte, 7000hp, 20kts, 224p; steel: 51deck, 76shields, 76CT; 8x1-102/40, 8x1-47/40, 3x1-7.7, 2-450TT	
		17	Pelorus	1897			
		18	Pactolus	1898			
		19	Pegasus	1898			
		20	Pyramus	1900			
		21	Perseus	1901			
		22	Pomone	1899			
		23	Psyche	1900			
		24	Prometheus	1899			
		25	Pioneer	1900			
		26	Pandora	1901			
Gem	1	27	Topaze	1904		3000t, 113.9x12.2x4.4m, 10b,2vte, 9800hp, 21.7kts, 296p; 51deck, 25shields, 76CT; 12x1-102/40, 8x1-47/40, 2-450TT	
Doterel	1	1	President (TS)	1879		1130t, 58.8ppx11.0x4.8m, 3b1hce, 1107hp, 11.5kts, 150p; 2x1-178/16MLR, 2x1-127/25, 6x1-11.4	





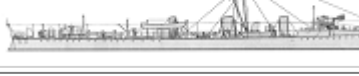





SL	Mariner	1	2	Melita	1889		970t, 50.9ppx9.9x4.3m, 3b,1hce, 1200hp, 12.5kts, 126p; 8x1-127/25, 8x1-11.4
	Nymphe	1	3	Nymphe	1889		1140t, 59.4ppx8.5x3.8m, 4b,2hte, 2000hp, 14.5kts, 138p; 8x1-127/25, 8x1-11.4
	Beagle	2	4	Beagle	1889		1170t, 59.4ppx8.5x3.8m, 4b2hte, 2000hp, 14.5kts, 138p; steel: 37deck; 8x1-127/25, 4x4-25/40, 4x5-11.4
			5	Basilisk	1889		
	Alert	2	6	Alert	1895		960t, 62.4x9.9x3.5m, 4b1vte, 1400hp, 13.2kts, 105p; 38deck; 6x1-102/40, 4x1-47/40, 2x1-11.4
			7	Torch	1895		
	Phoenix	2	8	Phoenix	1896		1050t, 62.4x9.9x4.2m, 4b,1vte, 1400hp, 13kts, 106p; 6x1-102/40, 4x1-47/40, 3x1-11.4
			9	Algerine	1896		
	Condor	5	10	Rosario	1899		980t, 62.2x9.9x3.5m, 4b,2vte, 1400hp, 13.5kts, 130p; steel: 38deck, 6shields; 6x1-102/40, 4x1-47/40, 3x1-11.4
			11	Shearwater	1900		
12			Vestal	1900			
13			Mutine	1900			
14			Rinaldo	1900			
Espiegle	6	15	Espiegle	1901		1070t, 64.1x10.1x3.4m, 4b,2vte, 1400hp, 13.2kts, 135p; 38deck, 6shields; 6x1-102/40, 4x1-47/40, 3x1-11.4	
		16	Fantome	1902			
		17	Merlin	1902			
		18	Odin	1902			
		19	Clio	1904			
		20	Cadmus	1904			
DV	Surprise	2	1	Surprise	1886		1650-1700t, 83.9x9.9x4.0m, 4b,2hdace, 3030hp, 17kts, 93p; steel: 10deck; 4x1-127/25(1), 4x1-57/40(1), 10x1-57/40(2), 2x1-11.4(1)
			2	Alacrity	1886		











CT	Scout	1	1	Fearless	1887		1580t, 68.6x10.4x4.4m, 4b,2hdace, 3200hp, 17kts, 147p; steel: 10deck, 25shields, 76TT; 4x1-120/40, 8x1-47/40, 2x1-11.4, (3+4)-356TT/TC
	Archer	7	2	Archer	1887		1950t, 73.2x11.0x4.4m, 4b,2hdace, 3500(2-7)-4500(8)hp, 16.5(2-7)-17.5(8)kts, 176p; steel: 10deck, 25shields, 76CT; 6x1-152/26, 8x1-47/40, 2x1-11.4, (1+4)-356TT/TC
			3	Mohawk	1887		
			4	Brisk	1888		
			5	Porpoise	1888		
			6	Cossack	1888		
			7	Tartar	1888		
			8	Racoon	1888		

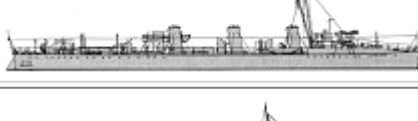







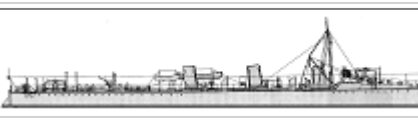
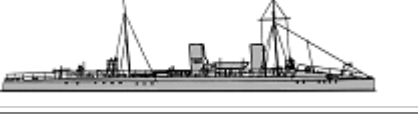

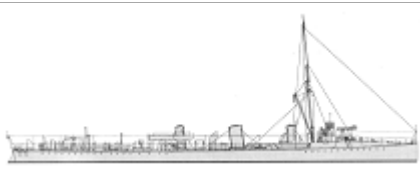

TORPEDO SHIPS





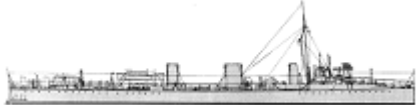

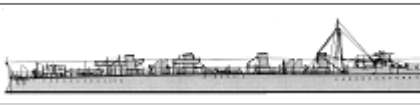

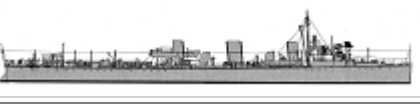

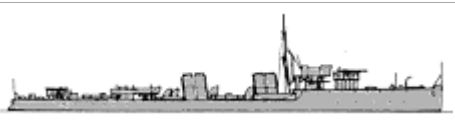
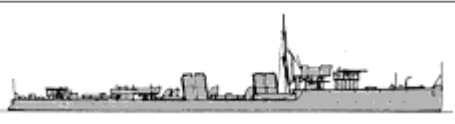
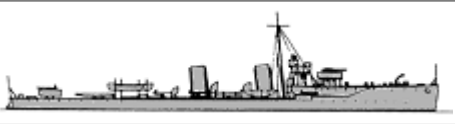

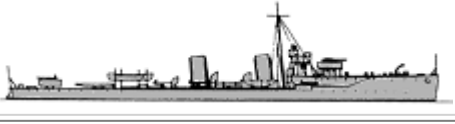

PGT	Rattlesnake	1	1	Rattlesnake	1887		550t, 61.0ppx7.0x3.2m, 4b,2vte, 2700hp, 19.2kts, 66p; steel: 19deck; 1x1-102/27, 6x1-47/40, (2+2x1)-356TT
	Grasshopper	2	2	Grasshopper	1888		526t, 61.0ppx7.0x3.2m, 4b,2vte, 2700hp, 19.2kts, 66p; 1x1-102/27, 6x1-47/40, (2+2x1)-356TT
			3	Sandfly	1888		
	Sharpshooter	8	4	Spanker	1890		735t, 70.1ppx8.2x3.2m, 4b,2vte, 3600hp, 19kts, 91p; 2x1-120/40, 4x1-47/40, (1+2x2)-356TT
			5	Speedwell	1890		
			6	Sheldrake	1890		
			7	Skipjack	1891		
			8	Seagull	1891		
			9	Salamander	1891		
	Alarm	11	10	Gleaner	1891		810t, 70.1ppx8.2x3.7m, 4b,3vte, 3500(12-20,22)-5000(21)hp, 18.7(12-20,22)-20.5(21)kts, 91p; 2x1-120/40, 4x1-47/40, 1x5-11.4, (1+2x1)-356TT(12,15,18,20,21), (1+2x2)-356TT(13,14,16,17,19,22)
			11	Gossamer	1891		
			12	Jason	1893		
			13	Circe	1893		
			14	Hebe	1894		
			15	Onyx	1894		
			16	Leda	1893		
			17	Alarm	1894		
			18	Jaseur	1893		
			19	Renard	1894		
	20	Niger	1893				
	21	Speedy	1894				
	22	Antelope	1894				

















Dryad	4	23	Dryad	1894		1070t, 80.1x9.3x3.5m, 4b,2vte, 6000hp, 20kts, 120p; 2x1-120/40, 4x1-57/40, 1x5-11.4, (1+4x1)-450TT
		24	Harrier	1895		
		25	Halcyon	1895		
		26	Hussar	1895		
Havock	2	1	Havock	1894		275t, 56.4x5.7x2.2m, 2b,2vte(1)-8b,2vte(2), 3800hp, 26kts, 46p; 1x1-76/40, 3x1-57/40, 2x1-450TT(1), (1+2x1)-450TT(2)
		2	Hornet	1894		
Daring	1	3	Daring	1895		288t, 56.4x5.8x2.1m, 3b,2vce, 3200hp, 27kts, 48p; 1x1-76/40, 3x1-57/40, 2x1-450TT
Ferret	2	4	Ferret	1895		280t, 60.1x6.0x2.7m, 4b,2vte, 4475hp, 27.2kts, 46p; 1x1-76/40, 3x1-57/40, 2x1-450TT
		5	Lynx	1895		
Ardent	3	6	Ardent	1895		295t, 61.5x5.8x2.2m, 3b,2vte, 4500(6,8)-4200(7)hp, 28(6)-29(7)-30(8)kts, 53p; 1x1-76/40, 5x1-57/40, 2x1-450TT
		7	Boxer	1895		
		8	Bruizer	1895		
Janus	3	9	Janus	1895		320t, 61.1x5.9x2.4m, 4b,2vte, 3900hp, 28kts, 54p; 1x1-76/40, 5x1-57/40, 2x1-450TT
		10	Lightning	1896		
		11	Porcupine	1896		
Banshee	3	12	Banshee	1895		345t, 64.9x5.9x2.9m, 4b,2vte, 4400hp, 28kts, 58p; 1x1-76/40, 5x1-57/40, 2x1-450TT
		13	Contest	1895		
		14	Dragon	1895		
Handy	3	15	Handy	1895		310t, 60.1x5.9x2.3m, 3b,2vte, 4000hp, 27kts, 55p; 1x1-76/40, 5x1-57/40, 2x1-450TT
		16	Hart	1896		
		17	Hunter	1896		
Rocket	3	18	Rocket	1895		325t, 62.2x6.0x2.21m, 4b,2vte, 4100hp, 27kts, 58p; 1x1-76/40, 5x1-57/40, 1x1-450TT(18,20), 2x1-450TT(19)
		19	Shark	1895		
		20	Surly	1895		
Charger	3	21	Charger	1896		295t, 59.4x5.6x2.2m, 4b,2vte, 3100(22,23)-3800(24)hp, 26.2kts, 53p; 1x1-76/40, 5x1-57/40, 2x1-450TT
		22	Hasty	1896		
		23	Dasher	1896		
Haughty	2	24	Haughty	1896		325t, 61.0x5.9x2.4m, 8b,2vte, 4200hp, 27kts, 54p; 1x1-76/40, 5x1-57/40, 2x1-450TT
		25	Hardy	1896		
Salmon	2	26	Salmon	1896		340t, 61.5x6.0x2.4m, 8b,2vte, 3700hp, 27kts, 52p; 1x1-76/40, 5x1-57/40, 2x1-450TT
		27	Snapper	1896		
Sunfish	3	28	Sunfish	1896		340t, 62.2x5.8x2.6m, 8b,2vte, 4000hp, 27kts, 58p; 1x1-76/40, 5x1-57/40, 2x1-450TT
		29	Opossum	1896		
		30	Ranger	1896		
Sturgeon	3	31	Sturgeon	1896		340t, 59.3x5.8x2.3m, 4b,2vte, 4000hp, 27.8kts, 52p; 1x1-76/40, 5x1-57/40, 2x1-450TT(31,32), 1x1-450TT(33)
		32	Starfish	1896		
		33	Skate	1896		



Swordfish	2	34	Swordfish	1896		355t, 62.3x5.8x2.4m, 8b,2vte, 4500hp, 27kts, 58p; 1x1-76/40, 5x1-57/40, 2x1-450TT
		35	Spitfire	1896		
Desperate	4	36	Desperate	1897		350t, 64.0x6.0x2.1m, 3b,2vte, 5700hp, 30kts, 54p; 1x1-76/40, 5x1-57/40, 2x1-450TT
		37	Fame	1897		
		38	Foam	1897		
		39	Mallard	1897		
Quail	3	40	Quail	1897		415t, 66.5x6.6x2.9m, 4b,2vte, 6300hp, 30kts, 56p; 1x1-76/40, 5x1-57/40, 2x1-450TT
		41	Thrasher	1897		
		42	Virago	1897		
Avon	3	43	Avon	1899		405t, 65.3x6.1x2.5m, 4b,2vte, 6300hp, 30kts, 60p; 1x1-76/40, 5x1-57/40, 2x1-450TT
		44	Bittern	1897		
		45	Otter	1900		
Earnest	6	46	Earnest	1897		415t, 66.5x6.6x3.0m, 4b,2vte, 6300hp, 30kts, 56p; 1x1-76/40, 5x1-57/40, 2x1-450TT
		47	Griffon	1897		
		48	Locust	1898		
		49	Panther	1898		
		50	Seal	1898		
		51	Wolf	1898		
Star	5	52	Star	1898		440t, 67.1x6.4x3.0m, 4b,2vte, 6200hp, 30kts, 58p; 1x1-76/40, 5x1-57/40, 2x1-450TT
		53	Whiting	1897		
		54	Bat	1897		
		55	Crane	1898		
		56	Flying Fish	1898		
Angler	2	57	Angler	1898		352t, 64.0x6.0x2.1m, 3b,2vte, 5700hp, 30kts, 54p; 1x1-76/40, 5x1-57/40, 2x1-450TT
		58	Ariel	1898		
Violet	2	59	Violet	1898		400t, 65.2(59)-65.5(60)x6.4x2.9m, 4b,2vte, 6300hp, 30kts, 58p; 1x1-76/40, 5x1-57/40, 2x1-450TT
		60	Sylvia	1899		
Gipsy	3	61	Gipsy	1898		400t, 65.7x6.5x2.5m, 4b,2vte, 6300hp, 30kts, 60p; 1x1-76/40, 5x1-57/40, 2x1-450TT
		62	Osprey	1898		
		63	Fairy	1898		
Fawn	2	64	Fawn	1898		440t, 67.1x6.4x3.0m, 4b,2vte, 6200hp, 30kts, 58p; 1x1-76/40, 5x1-57/40, 2x1-450TT
		65	Flirt	1899		
Conflict	3	66	Conflict	1899		360t, 62.7x6.1x2.5m, 3b,2vte, 4500hp, 27kts, 54p; 1x1-76/40, 5x1-57/40, 2x1-450TT
		67	Teazer	1899		
		68	Wizard	1899		
		69	Cheerful	1900		

DD	Cheerful	2	70	Mermaid	1899		400t, 65.5x6.4x2.5m, 4b,2vte, 6100hp, 30kts, 58p; 1x1-76/40, 5x1-57/40, 2x1-450TT
	Coquette	3	71	Coquette	1899		367t, 64.0x6.0x2.3m, 3b,2vte, 5700hp, 30kts, 54p; 1x1-76/40, 5x1-57/40, 2x1-450TT
			72	Cynthia	1899		
			73	Cygnets	1900		
	Leopard	1	74	Leopard	1899		400t, 65.3x6.1x2.5m, 4b,2vte, 6300hp, 30kts, 60p; 1x1-76/40, 5x1-57/40, 2x1-450TT
	Leven	1	75	Leven	1899		420t, 65.7x6.5x2.5m, 4b,2vte, 6100hp, 30kts, 58p; 1x1-76/40, 5x1-57/40, 2x1-450TT
	Fervent	2	76	Fervent	1900		320t, 62.4x5.8x2.2m, 2b,2vte, 4000hp, 26kts, 48p; 1x1-76/40, 5x1-57/40, 2x1-450TT
			77	Zephyr	1901		
	Zebra	1	78	Zebra	1900		365t, 62.4x5.8x2.3m, 3b,2vte, 4800hp, 27kts, 54p; 1x1-76/40, 5x1-57/40, 2x1-450TT
	Brazen	4	79	Brazen	1900		425(79-81)-385(82)t, 65.2(79,80)-66.5(81)-67.8(82)x6.1x2.5m, 4b,2vte, 5800hp, 30.5kts, 60p; 1x1-76/40, 5x1-57/40, 2x1-450TT
			80	Electra	1900		
			81	Recruit	1900		
			82	Vulture	1900		
Kestrel	1	83	Kestrel	1900		395t, 67.8x6.3x2.7m. 4b,2vte, 5800hp, 30kts, 58p; 1x1-76/40, 5x1-57/40, 2x1-450TT	
Spiteful	2	84	Spiteful	1900		450(84)-420(85)t, 67.1(84)-66.9(85)x6.4x2.7m, 4b,2vte, 6200hp, 30kts, 58p; 1x1-76/40, 5x1-57/40, 2x1-450TT	
		85	Peterel	1900			
Orwell	1	86	Orwell	1900		410t, 66.0x6.6x2.9m, 4b,2vte, 6300hp, 30kts, 56p; 1x1-76/40, 5x1-57/40, 2x1-450TT	
Stag	1	87	Stag	1900		371t, 64.0x6.0x2.2m, 3b,2vte, 5800hp, 30kts, 63p; 1x1-76/40, 5x1-57/40, 2x1-450TT	
Albatross	1	88	Albatross	1900		490t, 69.2x6.5x2.8m, 4b,2vte, 7500hp, 31.5kts, 69p; 1x1-76/40, 5x1-57/40, 2x1-450TT	
Taku	1	89	Taku	1898		305t, 59.1x6.4x2.0m, 4b,2vte, 6000hp, 30kts, 58p; 6x1-47/35, 2x1-356TT	

Bullfinch	2	90	Bullfinch	1901		390t, 65.4x6.3x2.4m, 4b,2vte, 5800hp, 30kts, 58p; 1x1-76/40, 5x1-57/40, 2x1-450TT
		91	Dove	1901		
Lee	1	92	Lee	1901		420t, 65.5x6.4x2.9m, 4b,2vte, 6300hp, 30kts, 58p; 1x1-76/40, 5x1-57/40, 2x1-450TT
Myrmidon	2	93	Myrmidon	1901		420(93)-440(94)t, 67.0-67.1x6.4x2.7-2.8m, 4b,2vte, 6300hp, 56p; 1x1-76/40, 5x1-57/40, 2x1-450TT
		94	Syren	1902		
Falcon	2	95	Falcon	1901		420t, 65.7(95)-65.4(96)x6.5x2.7m, 4b,2vte, 6100hp, 30kts, 58p; 1x1-76/40, 5x1-57/40, 2x1-450TT
		96	Ostrich	1901		
Thorn	3	97	Thorn	1901		425t, 67.7x6.3x2.7m, 4b,2vte, 6400hp, 30kts, 60p; 1x1-76/40, 5x1-57/40, 2x1-450TT
		98	Tiger	1901		
		99	Vigilant	1901		
Kangaroo	1	100	Kangaroo	1901		420t, 67.0x6.4x2.7m, 4b,2vte, 6100hp, 30kts, 56p; 1x1-76/40, 5x1-57/40, 2x1-450TT
Greyhound	3	101	Greyhound	1902		430t, 65.4x6.4x4.0m, 4b,2vte, 6100hp, 30kts, 58p; 1x1-76/40, 5x1-57/40, 2x1-450TT
		102	Racehorse	1902		
		103	Roebuck	1902		
Success	1	104	Success	1902		420t, 65.5x6.4x2.7m, 4b,2vte, 6300hp, 30kts, 58p; 1x1-76/40, 5x1-57/40, 2x1-450TT
Vixen	1	105	Vixen	1902		445t, 65.7x6.5x2.5m, 4b,2vte, 6300hp, 30kts, 58p; 1x1-76/40, 5x1-57/40, 2x1-450TT
Lively	2	106	Lively	1902		435t, 66.8x6.7x2.6m, 4b,2vte, 6250hp, 30kts, 56p; 1x1-76/40, 5x1-57/40, 2x1-450TT
		107	Sprightly	1902		
Express	1	108	Express	1902		540t, 73.0x7.2x3.1m, 4b,2vte, 9250hp, 31kts, 74p; 1x1-76/40, 5x1-57/40, 2x1-450TT
Arab	1	109	Arab	1903		530t, 70.7x6.8x3.0m, 4b,2vte, 8600hp, 30.7kts, 69p; 1x1-76/40, 5x1-57/40, 2x1-450TT
Velox	1	110	Velox	1904		445t, 65.5x6.0x2.7m, 4b,4st/vte(2), 8000/200hp, 30kts, 63p; 1x1-76/40, 5x1-57/40, 2x1-450TT
Erne	3	111	Erne	1904		620t, 71.2x7.2x3.0m, 4b,2vte, 7000hp, 25.5kts, 70p; 1x1-76/40, 5x1-57/40, 2x1-450TT
		112	Ettrick	1904		

						
		113	Exe	1904		
Usk	3	114	Usk	1904		660t, 70.5x7.2x3.1m, 4b,2vte, 7500hp, 26kts, 70p; 1x1-76/40, 5x1-57/40, 2x1-450TT
		115	Teviot	1904		
		116	Ribble	1904		
Derwent	2	117	Derwent	1904		620t, 68.7x7.2x2.7m, 4b,2vte(117)-4b,3st(118), 7000hp, 25.6(117)-26.2(118)kts, 70p; 1x1-76/40, 5x1-57/40, 2x1-450TT
		118	Eden	1904		
Foyle	2	119	Foyle	1904		625t, 69.1x7.2x2.9m, 4b,2vte, 7000hp, 25.6kts, 70p; 1x1-76/40, 5x1-57/40, 2x1-450TT
		120	Itchen	1904		
Welland	1	121	Welland	1904		660t, 70.5x7.2x3.1m, 4b,2vte, 7500hp, 26kts, 70p; 1x1-76/40, 5x1-57/40, 2x1-450TT
Cherwell	2	122	Cherwell	1904		615(122)-620(123)t, 70.1x7.2x3.0m, 4b,2vte, 7000hp, 25.5kts, 70p; 1x1-76/40, 5x1-57/40, 2x1-450TT
		123	Dee	1904		
Arun	2	124	Arun	1904		625t, 69.1x7.2x2.9m, 4b,2vte, 7000hp, 25.6kts, 70p; 1x1-76/40, 5x1-57/40, 2x1-450TT
		125	Blackwater	1904		
Waveney	1	126	Waveney	1904		620t, 68.7x7.2x2.7m, 4b,2vte, 7000hp, 25.6kts, 70p; 1x1-76/40, 5x1-57/40, 2x1-450TT
TB2	2	1 - 2	TB4, 6	1879		33t, 26.5x3.1x1.6m, 1b,1hce, 460hp, 20kts, 15p; 2-356TC
TB17	1	3	TB17	1878		33t, 26.2x3.4x1.4m, 1b,1hce, 450hp, 21kts, 15p; 2-356TC
TB21	2	4 - 5	TB21, 22	1885		63t, 34.6x3.8x1.8m, 1b,1hce, 730hp, 18kts, 14p; 2x1-25/40, (2+1x1)-356TT
TB81	1	6	TB81	1885		137t, 46.9x5.3x2.9m, 1b,1vce, 1330hp, 23.7kts, 25p; 4x1-47/40, (1+2x1)-356TT
TB23	1	7	TB24	1886		67t, 34.6x3.8x2.1m, 1b,1hce, 600(17)-500(18)hp, 18.7kts, 14p; 2x1-47/40, (2+1x1)-356TT
TB25	1	8	TB25	1886		60t, 39.1x3.8x1.8m, 1b,1hce, 591hp, 19.4kts, 16p; 3x2-25/40, 2x2-356TT
TB26	23	9 - 31	TB26, 27, 29, 41-60	1886 - 1887		60t, 38.9x3.8x2.5m, 1b,1hce, 700-750hp, 19.5-21.5kts, 16p; 3x2-25/40, 2x2-356TT
TB30	21	32 - 52	TB30-33, 61-74, 76-78	1886 - 1887		60t, 38.2x4.0x2.5m, 1b,1hce, 670hp, 19.5kts, 16p; 2x1-25/40, (1+2x2)-356TT
TB34	5	53 - 57	TB34-38	1886 - 1887		60(53-55)-66(56,57)t, 38.1pp(53-55)-40.3pp(56,57)x4.4x1.3m, 1b,1hce, 950hp, 18-19kts, 16p; 2x1-47/40(56,57), 2x1-25/40(53-55), (1+2x2)-356TT

TB	TB79	1	58	TB79	1886		75t, 39.2x4.0x1.7m, 1b,1vte, 1000hp, 22.2kts, 16p; 2x1-47/40, (2+1x1)-356TT
	TB80	1	59	TB80	1887		105t, 41.2ppx4.3x1.8m, 2b,1vte, 1539hp, 23kts, 21p; 3x1-47/40, (1+1x2)-356TT
	TB39	2	60, 61	TB39, 40	1885	No picture	40t, 30.5ppx3.8x1.2m, 1b,1hce, 500hp, 15p; 2x5-11.4, 2-356TC
	Baluchi	3	62 - 64	TB100, 102, 103	1888		96t, 41.0x4.5x2.1m, 2b,1hce, 1260hp, 23kts, 18p; 2x2-25/40, (1+2x2)-356TT
	Gurkha	1	65	TB101	1888		92t, 41.2x4.3x2.1m, 2b,1hce, 1000hp, 21.5kts, 18p; 2x2-25/40, (1+2x2)-356TT
	Mahratta	3	66 - 68	TB104 - 106	1889		95t, 41.2x4.4x2.3m, 2b,1hce, 1000hp, 22kts, 18p; 2x2-25/40, (1+2x2)-356TT
	TB82	6	69 - 74	TB82-87	1889		85t, 39.7ppx4.1x1.8m, 1b,1vte, 1800hp, 23kts, 19p; 3x1-47/40, (1+1x2)-356TT
	TB88	2	75	TB88	1894		112t, 43.3ppx4.5x2.3m, 1b,1vte, 1850hp, 23.5kts, 18p; 3x1-47/40, (1+1x2)-450TT
			76	TB89	1894		
	TB91	2	77	TB91	1894		141t, 43.3(79)-42.8(80)x4.7x2.3m, 1b,1vte, 2350hp, 24.5kts, 18p; 3x1-47/40, (1+1x2)-450TT
			78	TB92	1894		
	TB93	1	79	TB93	1894		136t, 42.8x4.7x1.6m, 2b,2vte, 2200hp, 23.5kts, 18p; 3x1-47/40, (1+1x2)-450TT
	TB94	3	80	TB94	1894		130t, 43.4ppx4.7x2.7m, 2b,2vte, 2000hp, 23kts, 18p; 3x1-47/40, (1+1x2)-450TT
			81	TB95	1895		
			82	TB96	1895		
	TB97	1	83	TB97	1894		130t, 42.8ppx4.9x2.3m, 2b,2vte, 2000hp, 23kts, 18p; 3x1-47/40, (1+1x2)-450TT
	TB90	1	84	TB90	1895		112t, 42.8ppx4.4x2.0m, 1b,1vte, 1500hp, 23kts, 18p; 3x1-47/40, (1+1x2)-450TT
	TB98	4	85	TB98	1901		185t, 50.0x5.2x1.8m, 2b,2vte, 3000hp, 25kts, 32p; 3x1-47/40, 3x1-450TT
			86	TB99	1901		
			87	TB107	1901		
88			TB108	1901			
TB109	5	89	TB109	1902		200t, 50.6x5.3x1.7m, 2b,2vte, 3050hp, 25kts, 32p; 3x1-47/40, 3x1-450TT	
		90	TB110	1902			
		91	TB111	1902			
		92	TB112	1903			
		93	TB113	1903			
TB114	3	94	TB114	1904		219t, 50.3ppx5.3x2.6m, 2b,2vte, 3050hp, 25kts, 32p; 3x1-47/40, 3x1-450TT	
		95	TB115	1904			
		96	TB116	1904			
TB51	1	1	TB51	1878		11t, 18.5x2.3x0.9m, 1b,1hce, 120-150hp, 15kts, 7p; 2-356TC	
TB63	1	2	TB63	1878		15t, 18.3x2.3xm, 1b,1hce, hp, 16kts, 7p; 2-356TC	
		3 -	TB65-67, 69-	1880 -			

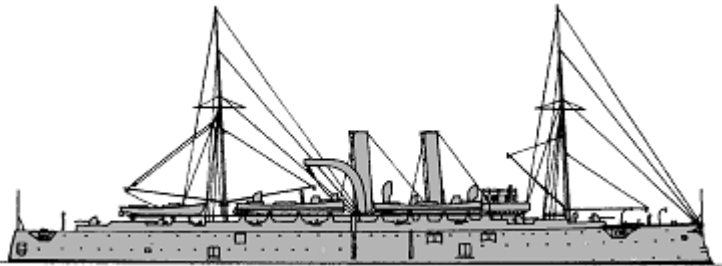
TB2cl	TB64	7	9	71, 73	1882	No picture	13t, 19.2-20.1ppx2.4x1.0m, 1b,1hce, 110hp, 16.5kts, 7p; 2-356TC
	TB76	9	10 - 18	TB76-78, 80, 87, 89, 94, 95	1882 - 1883	No picture	13t, 19.5x2.3x1.1m, 1b,1hce, 170hp, 16.5kts, 7p; 2-356TT
	TB74	2	19, 20	TB74, 96	1883	No picture	12t, 18.5pp-19.4ppx2.4x1.1m, 1b,1hce, 220hp, 16kts, 7p; 1x1-11.4, 2-356TT
	WTB1	11	21 - 31	WTB1, 3-12	1883 - 1888	No picture	11-14t, 17.1x2.8x1.5m, 1b,1hce, 140-200hp, 16kts, 9p; (1-2)x1-11.4, 1-356TT or 2-356TC or 1x1-356TT
	TB99	2	32, 33	TB99, 100	1885 - 1886	No picture	12t, 19.8x2.4x1.1m, 1b,1hce, 189hp, 16.8kts, 7p; 2-356TT
	TB49	1	34	TB49	1888		15-16t, 18.1pp-18.3ppx2.5-2.6x0.9m, 1b,1vte, 9p; 1x1-25/40, 1x1-356TT
	TB39	10	35 - 44	TB39 - 48	1889		17t, 18.3ppx2.8xm, 1b,1vte, 240hp, 16.5kts, 9p; 1x1-25/40, 2-356TC
CTB	Hecla	1	1	Hecla	1879	No picture	6400t, 119.6ppx11.8x6.9m, b,2hice, 1758hp, 12.1kts, 277p; 4x1-160/16MLR, 1x1-127/25, 1x1-121/21, 4 TB2cl
	Vulcan	1	2	Vulcan	1891		6620t, 113.7x17.7x6.7m, 5b,2vte, 12000hp, 20kts, 432p; steel: 127deck, 152CT; 8x1-120/40, 12x1-47/40, 12x1-11.4, 6TT, 9 TB2cl







SUBMARINES



SS	Holland	5	1	No1	1903		110/122t, 19.5x3.6x3.0m, 1pe/em, 160/74hp, 8/7kts, 8p, 30m; 1-356TT
			2	No2	1902		
			3	No3	1902		
			4	No4	1903		
			5	No5	1903		
	A	3	6	A2	1904		165/180t, 30.5x3.5x3.1m, 1pe/em, 450/80hp, 11.5/7kts, 11p, 30m; 2-450TT
			7	A3	1904		
			8	A4	1904		
B	1	9	B1	1904		287/316t, 43.3x4.1x3.4m, 1pe/em, 600/290hp, 12/6kts, 15p, 30m; 2-450TT	

ESCORTS

AFPV	-	1	1	Julia	1897	310brt
------	---	---	---	-------	------	--------

OTHER FIGHTING SHIPS

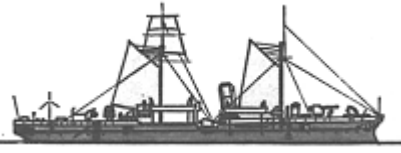
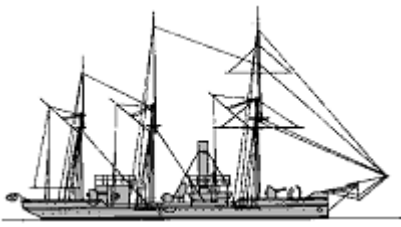
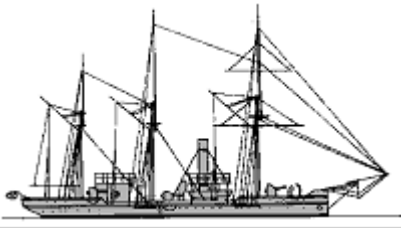
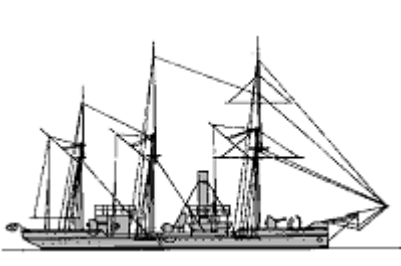
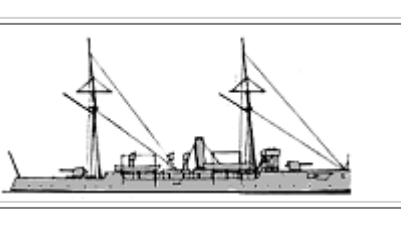
PG	Plucky	1	1	Plucky	1870		212t, 24.4x7.7x1.9m, 1b,2hse, 234hp, 7.7kts, 31p; 1x1-229MLR
	Ant	18	2	Comet	1870		254t, 25.9x8.0x1.8-2.0m, 1b,2hse(t), 260hp, 8.5kts, 30p; 1x1-254MLR
			3	Bustard	1871		
			4	Kite	1871		
			5	Mastiff	1871		
			6	Bloodhound	1871		
			7	Arrow	1871		
			8	Bonetta	1871		
			9	Badger	1872		
			10	Fidget	1872		
			11	Bulldog	1872		
			12	Pike	1872		
			13	Pickle	1872		
			14	Snap	1872		
			15	Ant	1873		
			16	Cuckoo	1873		
			17	Hyaena	1873		
			18	Pincher	1879		
			19	Griper	1879		
	Forester	2	20	Firm	1877		455t, 38.1ppx7.2x3.2m, 2b,2hce, 500hp, 10kts, 60p; 2x1-127/25, 2x1-95/21
			21	Firebrand	1877		
	Medina	8	22	Sabrina	1876		363t, 33.5x10.4x1.8m, 1b,2hse, 310hp, 9.5kts, 51p; 3x1-160/16MLR
			23	Spey	1876		
24			Tay	1876			
25			Tees	1876			
26			Don	1877			
27			Slaney	1877			
28			Trent	1877			
29	Tweed	1877					
Banterer	4	30	Redwing	1880		465t, 38.1ppx7.2x3.1m, 4b,1hce, 440hp, 9.5kts, 60p; 2x1-127/25, 2x1-95/21, 2x1-25/40	
		31	Banterer	1882			
		32	Bullfrog	1885			
		33	Cockchafer	1883			
Bouncer	2	34	Bouncer	1881		265t, 26.6x8.0x2.0m, 1b,2hse, 230hp, 8.5kts, 30p; 1x1-254/15MLR	
		35	Insolent	1881			
Handy	1	36	Excellent	1883	No picture	508t, 35.1x11.3x2.8m, 2b,2hse, 310hp, 8.5kts; 1x1-343/30	

	Albacore	1	37	Albacore	1884		560t, 41.2ppx7.9x2.6m, 4b,1vce, 650hp, 10.7kts, 60p; 2x1-127/25, 2x1-102/27, 2x1-25/40
	Curlew	2	38	Curlew	1886		950t, 59.4ppx8.5x3.2m, 4b,2hdace, 1500hp, 14.5kts, 46p; 1x1-152/26, 3x1-127/25, 7x1-11.4, (1+2)-356TT/TC
			39	Landrail	1887		
	Bramble	3	40	Rattler	1887		810t, 50.3ppx8.8x3.4m, 2b,1vte, 1200(38)-1000(39,40)hp, 13kts, 76p; 6x1-102/40, 4x1-11.4
			41	Lizard	1887		
			42	Cockatrice	1887		
	Pigmy	5	43	Pheasant	1888		755t, 50.3ppx9.1x3.4m, 2b,1vte, 1200hp, 13.2kts, 76p; 6x1-102/27, 4x1-11.4
			44	Partridge	1888		
			45	Peacock	1888		
			46	Pigmy	1889		
			47	Pigeon	1889		
	Redbreast	7	48	Lapwing	1889		805t, 50.3ppx9.5x3.4m, 2b,1vte, 1200hp, 13kts, 76p; 6x1-102/27(47-52), 6x1-102/28(46), 2x1-47/40(50-52), 4x1-11.4(46-49), 2x1-11.4(46, 50-52)
			49	Redbreast	1889		
			50	Redpole	1890		
			51	Ringdove	1890		
			52	Sparrow	1890		
			53	Thrush	1890		
			54	Widgeon	1890		
	Bramble	4	55	Bramble	1900		710t, 57.2x10.1x2.4m, 4b,2vte, 1300hp, 13.5kts, 85p; 2x1-102/40, 4x1-76/40, 10x1-11.4
			56	Britomart	1900		
			57	Dwarf	1899		
			58	Thistle	1901		
APG	-	1	1	Otter	1884		220t
PGR	Heron	4	1-4	Nightingale, Robin, Sandpiper, Snipe	1898	No picture	85t, 32.8x6.1x0.6m, 1b,1vte, 240hp, 9kts, 25p; 2x1-57/40
	Woodcock	2	5	Woodcock	1898	No picture	150t, 44.2x7.3x0.6m, 1b,1vte, 550hp, 13kts, 25p; 2x1-57/40, 4x1-7.9
			6	Woodlark	1898		
	Teal	2	7	Teal	1901		180t, 48.7x7.5x0.8m, 1b,1vte, 670hp, 13kts, 35p; 2x1-57/40, 4x1-7.9
			8	Moorhen	1901		
Widgeon	1	9	Widgeon	1904		195t, 48.7x7.5x1.0m, 1b,1vte, 800hp, 12.5kts, 35p; 2x1-57/40	
APGR	-	1	1	Kinsha	1900		616t; 2-76/40

© Ivan Gogin, 2014

[home](#)[World navies yesterday](#)[1905](#)

United States of America 01 January 1905

CAPITAL SHIPS

BB	Texas	1	1		Texas	1895	A line drawing of the USS Texas (BB-3), a pre-dreadnought battleship with two masts and two funnels.	6665t, 94.1x19.5x6.9m, 4b,2vte, 8600hp, 17kts, 392p; Harvey: 305belt, 76deck, 305turrets, 305CT; 2x1-305/35, 2x1-152/35, 4x1-152/30, 10x1-57/45, 2x1-57/40, 6x1-37/40, 4x5-37/20, 4-356TT
	Indiana	2	B1		Indiana	1895	A line drawing of the USS Indiana (BB-3), a pre-dreadnought battleship with two masts and two funnels.	11688t, 107.0x21.1x7.3m, 6b,2vte, 9000hp, 15kts, 473p; Harvey: 457belt, 76deck, 432turrets, 254CT; 2x2-330/35, 4x2-203/37, 4x1-152/40, 20x1-57/40, 6x5-37/20, 6-450TT
		3	B2		Massachusetts	1896		
		4	B3		Oregon	1896		
	Iowa	1	5	B4	Iowa	1897	A line drawing of the USS Iowa (BB-3), a pre-dreadnought battleship with two masts and two funnels.	12647t, 110.5x22.0x7.3m, 5b,2vte, 11000hp, 16kts, 486p; Harvey: 356belt, 76deck, 381turrets, 254CT; 2x2-305/35, 4x2-203/37, 6x1-102/40, 20x1-57/40, 4x5-37/20, 4-356TT
	Kearsarge	6	B5		Kearsarge	1900	A line drawing of the USS Kearsarge (BB-5), a pre-dreadnought battleship with two masts and two funnels.	12850t, 114.4x22.0x7.2m, 5b,2vte, 10000hp, 16kts, 553p; Harvey: 419belt, 127deck, 432turrets, 254CT; 2x2-330/35, 2x2-203/37, 14x1-127/40, 20x1-57/40, 8x5-37/20, 4-450TT
		7	B6		Kentucky	1900		
	Illinois	8	B7		Illinois	1901	A line drawing of the USS Illinois (BB-1), a pre-dreadnought battleship with two masts and two funnels.	12250t, 114.4(8)-114.0(9,10)x22.0x7.2m, 8b,2vte, 10000hp, 16kts, 536p; Harvey: 419belt, 127deck, 356turrets, 254CT; 2x2-330/35, 14x1-152/40, 16x1-57/40, 6x1-37/40(8,10), 4c1-37/40(9), 4-450TT
		9	B8		Alabama	1900		
		10	B9		Wisconsin	1901		
		11	B10		Maine	1902		
		12	B11		Missouri	1903		



	Maine	3	13	B12	Ohio	1904	A side-view line drawing of the USS Ohio (BB-3), a pre-dreadnought battleship with two masts and three funnels.	13700t, 120.1x22.0x7.2-7.4m, 24b,2vte(11)-12b,2vte(12,13), 16000hp, 18kts, 561p; 279belt, 102deck, 305turrets, 254CT; 2x2-305/40, 16x1-152/49, 6x1-76/50, 8x1-47/40, 6x1-37/40, 2-450TT
MON	Passaic	1	1		Jason	1863	A side-view line drawing of the USS Jason (M1), a small monitor with a single turret.	1875t, 61.0x14.0x3.2m, 2b,1vl, 320hp, 7kts, 75p; iron: 127side, 51deck, 279turret; 1x2-381/11, 2x1-76/11
	Canonicus	1	2		Canonicus	1864	A side-view line drawing of the USS Canonicus (M2), a small monitor with a single turret.	2100t, 68.6x13.2x4.0m, 2b,1vl, 320hp, 8kts, 100p; iron: 127side, 38deck, 254turret; 1x2-381/12
	Amphitrite	4	3	M2	Amphitrite	1895	A side-view line drawing of the USS Amphitrite (M3), a monitor with a single turret.	3990t, 80.1(3)-79.9(4)-80.2(5,6)x16.9x4.4(3-5)-4.5(6)m, 4b,2hce(3)-4b,2hte(4)-6b,2hce(5,6), 1600(3,5,6)-3000(4)hp, 12(3,5,6)-14.5(4)kts, 150-191p; steel, iron: 229(3,4)-178(5,6)belt, 44deck, 190(3,4)-292(5,6)turrets, 190(3-5)-229(6)CT; 2x2-254/31(3-5), 1x2-254/35(6), 1x2-254/31(6), 2x1-102/40(3,4), 2x1-57/40, 2x5-37/20
			4	M3	Monadnock	1896		
			5	M4	Terror (TS)	1896		
			6	M5	Miantonomoh	1891		
Monterey	1	7	M6	Monterey	1893	A side-view line drawing of the USS Monterey (M6), a monitor with a single turret.	4084t, 79.5x18.0x4.5m, 4b,2vte, 5250hp, 13.6kts, 218p; Harvey: 330belt, 64deck, 203turrets, 254CT; 1x2-305/35, 1x2-254/31, 6x1-57/40	
Arkansas	4	8	M7	Arkansas	1902	A side-view line drawing of the USS Arkansas (M7), a monitor with a single turret.	3225t, 77.8x15.2x3.8m, 4b,2vte, 2400hp, 12.5kts, 220p; Harvey: 279belt, 38deck, 254turret, 190CT; 1x2-305/40, 4x1-102/50, 3x1-57/40	
		9	M8	Nevada	1903			
		10	M9	Florida	1903			
		11	M10	Wyoming	1902			

CRUISERS



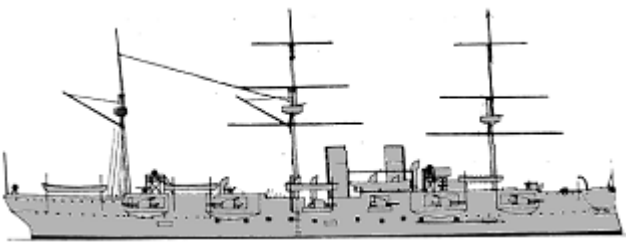
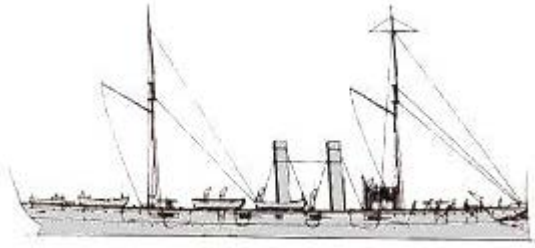
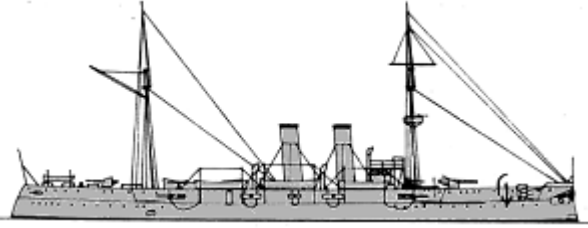
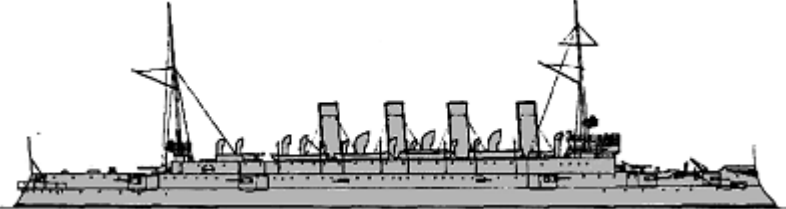
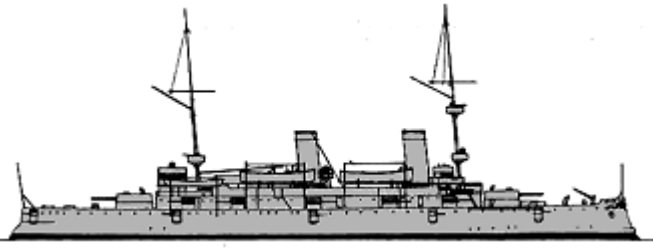
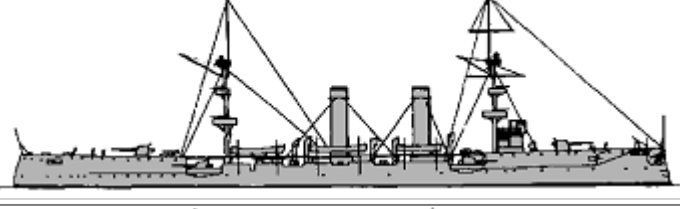
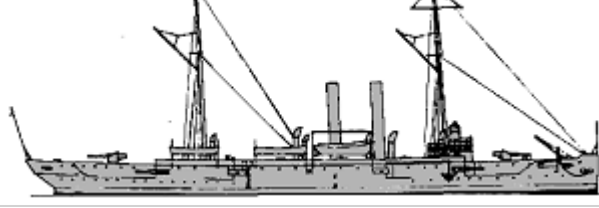

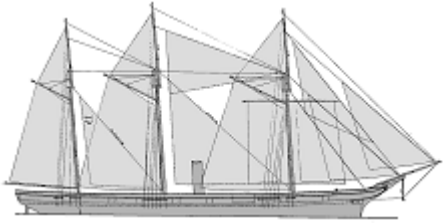
CA	New York	1	1	ACR2	New York	1893	A side-view line drawing of the USS New York (ACR-2), a protected cruiser with two masts and two funnels.	9021t, 117.0x19.8x7.3m, 8b,2vte, 16000hp, 20kts, 566p; nickel steel: 102belt, 152deck, 140gunhouses, 190CT; (2x2+2x1)-203/37, 12x1-102/40, 8x1-57/45, 4x1-37/40, 3-356TT
	Brooklyn	1	2	ACR3	Brooklyn	1896	A side-view line drawing of the USS Brooklyn (ACR-3), a protected cruiser with two masts and two funnels.	10068t, 122.7x19.7x7.3m, 7b,2vte, 16000hp, 20kts, 581p; Harvey and nickel steel: 4x2-203/37, 12x1-127/40, 12x1-57/45, 4x1-37/40, 5-450TT







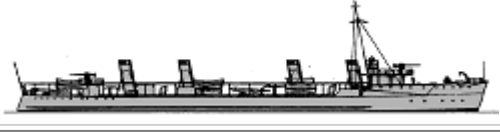
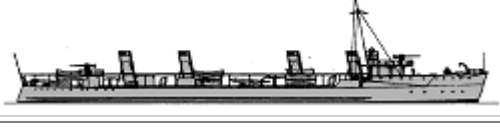



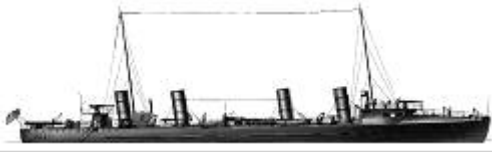

CL	Hartford	1	1		Hartford (TS)	1859	A three-masted sailing ship with a single funnel, shown from a starboard profile view.	2550t, 68.6ppx13.4x7.1m, 2b,1vce, 696hp, 9.5kts, 310p; 16x1-229/15, 1x1-203/15, 13x1-127/40
	Galena	1	2		Mohican (TS)	1885	A three-masted sailing ship with a single funnel, shown from a starboard profile view.	1900t, 65.8ppx11.3x5.0m, 10b,1hcr, 800hp, 11kts, 230p; 6x1-229/15, 1x1-135/21
	Atlanta	2	3		Atlanta	1886	A three-masted sailing ship with two funnels, shown from a starboard profile view.	3189t, 86.3x12.8x5.2m, 8b,1hce, 3500hp, 13kts, 284p; steel: 38deck, 51barb; 2x1-203/31, 6x1-152/30, 2x1-57/40, 2x1-47/40, 2x1-37/20
			4		Boston	1887		
	Chicago	1	5		Chicago	1889	A three-masted sailing ship with two funnels, shown from a starboard profile view.	5000t, 104.3x14.7x5.8m, 10b,2hte, 9000hp, 18kts, 471p; steel: 29belt, 38deck, 25battery, 76CT; 4x1-203/37, 14x1-127/40, 2x1-57/40, 2x1-37/20
	Baltimore	1	6	C3	Baltimore	1890	A three-masted sailing ship with two funnels, shown from a starboard profile view.	5436t, 102.1x14.8x5.9m, 8b,2hte, 10750hp, 19kts, 386p; steel: 102slopes, 64deck, 76CT; 12x1-152/41, 4x1-57/40, 2x1-47/40, 2x1-37/20
	San Francisco	1	7	C5	San Francisco	1890	A three-masted sailing ship with two funnels, shown from a starboard profile view.	4583t, 98.9x15.0x5.7m, 4b,2hte, 10500hp, 19kts, 384p; steel: 76slopes, 51deck, 76CT; 12x1-152/41, 4x1-57/40, 4x1-47/40, 2x1-37/20
	Newark	1	8	C1	Newark	1891		4592t, 100.0x15.0x5.7m, 4b,2hte, 8500hp, 18kts, 384p; steel: 76slopes, 51deck, 76CT; 12x1-152/41, 4x1-57/40, 4x1-47/40, 2x1-37/20

							
Montgomery	3	9	C9	Montgomery	1894		2235t, 82.1x11.3x4.4m, 6b,2vte, 5400hp, 17kts, 274p; steel: 13slopes, 13deck, 51CT; 9x1-127/40, 6x1-57/45, 2x1-37/40
		10	C10	Detroit	1893		
		11	C11	Marblehead	1894		
Cincinnati	2	12	C7	Cincinnati	1894		3339t, 93.2x12.8x5.5m, 8b,2vte, 10000hp, 19kts, 322p; steel: 64slopes, 25deck, 102shields, 51CT; 11x1-127/40, 8x1-57/45, 2x1-37/40(12), 4x1-37/40(13)
		13	C8	Raleigh	1894		
Columbia	2	14	C12	Columbia	1894		8270t, 125.9x17.7x6.9m, 8b,3vte, 21000hp, 21kts, 477p; steel: 102slopes, 64deck, 102casemates, 127CT; 1x1-203/40, 2x1-152/40, 8x1-102/40, 12x1-57/45, 4x1-37/40, 4-450TT(15), 4-356TT(14)
		15	C13	Minneapolis	1894		
Olympia	1	16	C6	Olympia	1895		6558t, 104.9x16.2x6.6m, 6b,2vte, 13500hp, 20kts, 447p; Harvey: 121slopes, 51deck, 89turrets, 127CT; 2x2-203/37, 10x1-127/40, 14x1-57/45, 6x1-37/40
New Orleans	2	17		New Orleans	1898		4011t, 108.0x13.3x5.5m, 4b,2vte, 7500hp, 20kts, 366p; 89slopes, 32deck, 102CT; 6x1-152/50, 4x1-127/50, 10x1-57/40, 8x1-37/20, 3-450TT
		18		Albany	1900		
Denver	5	19	C14	Denver	1904		3514t, 94.1x13.4x4.8m, 6b,2vte, 4500hp, 16.5kts, 339p; 64slopes, 8deck, 44casemates; 10x1-127/50, 8x1-57/50, 2x1-37/50
		20	C15	Des Moines	1904		
		21	C16	Chattanooga	1904		
		22	C18	Tacoma	1904		
		23	C19	Cleveland	1903		
		1		Alert	1875		

SL	Alert	2	2	Ranger	1876		1020t, 53.3ppx9.8x3.9m, 5b,1hcr, 380hp, 10kts, 148p; 1x1-279/15(1), 2x1-229/15(1), 1x1-135/21, 4x1-37/20(1)
	Enterprise	1	3	Adams	1876		1375t, 56.4ppx10.7x4.4m, 8b,1hcr, 700-800hp, 10-11kts, 178-193p; 4x1-229/15, 1x1-203/18, 1x1-135/21, 4x1-37/20
AMC	-	4	1	Buffalo (TS)	1892		6888t, 123.8x14.7x6.7m, 1vte, 3600hp, 14.5kts; 2x1-127/40, 4x1-102/40, 6x1-57/40
			2	Panther (TS)	1889		4260t, 98.9x12.3x5.6m, 1vte, 3200hp, 13kts; 6x1-127/40, 2x1-102/40, 6x1-47/40
			3	Prairie (TS)	1890		6872t, 123.4x14.7x6.7m, 1vte, 3800hp, 14.5kts; 10x1-152/30, 6x1-57/40
			4	Yankee (TS)	1892		6888t, 123.8x14.7x6.7m, 1vte, 3800hp, 14.5kts; 10x1-127/40, 6x1-57/40

TORPEDO SHIPS

DD	Farragut	1	1	TB11	Farragut	1899		279t, 65.2x6.3x1.8m, 3b,2vte, 5878hp, 30kts, 66p; 4x1-57/50, 2x1-450TT
	Bailey	1	2	TB21	Bailey	1901		235t, 62.5x5.8x1.8m, 4b,2vte, 5600hp, 30kts, 56p; 4x1-57/50, 2x1-450TT
	Bainbridge	5	3	DD1	Bainbridge	1902		420t, 76.2x7.2x2.0m, 4b,2vte, 8000hp, 29kts, 73p; 2x1-76/50, 5x1-57/50, 2x1-450TT
			4	DD2	Barry	1902		
			5	DD3	Chauncey	1902		
			6	DD4	Dale	1902		
			7	DD5	Decatur	1902		
	Paul Jones	3	8	DD10	Paul Jones	1903		480t, 76.4x7.2x2.2m, 4b,2vte, 8000hp, 29kts, 73p; 2x1-76/50, 5x1-57/50, 2x1-450TT
			9	DD11	Perry	1902		
			10	DD12	Preble	1903		
	Stewart	1	11	DD13	Stewart	1902		420t, 76.3x7.2x2.0m, 4b,2vte, 8000hp, 29kts, 71p; 2x1-76/50, 5x1-57/50, 2x1-450TT
	Truxtun	3	12	DD14	Truxtun	1902		433t, 79.1x7.1x1.8m, 4b,2vte, 8300hp, 30kts, 73p; 2x1-76/50, 6x1-57/50, 2x1-450TT
			13	DD15	Whipple	1902		
			14	DD16	Worden	1902		
	Hopkins	2		DD6	Hopkins	1903		408t, 75.8x7.5x1.8m, 4b,2vte, 7200hp, 29kts, 78p; 2x1-76/50, 6x1-57/50, 2x1-450TT

		16	DD7	Hull	1903			
Lawrence	2	17	DD8	Lawrence	1903		430t, 75.1x6.8x2.0m, 4b,2vte, 8400hp, 28.4kts, 78p; 7x1-57/50, 2x1-450TT	
		18	DD9	MacDonough	1903			
TB	1	1	WTB1	Stiletto	1887	No picture	31t, 28.6x3.5x0.9m, 1b,1vc, 359hp, 18.2kts, 6p; 2Howel torps	
	1	2	TB1	Cushing	1890		116t, 42.7x4.6x1.5m, 2b,2vqe, 1600hp, 23kts, 22p; 3x1-57/40, (1+2x1)-450TT	
	1	3	TB2	Ericsson	1897		120t, 45.6x4.7x1.5m, 2b,2vqe, 1800hp, 24kts, 22p; 4x1-37/40, (1+2x1)-450TT	
	Foote	3	4	TB3	Foote	1897		142t, 48.8x4.9x1.5m, 2b,2vte, 2000hp, 25kts, 20p; 3x1-37/40, 3x1-450TT
			5	TB4	Rodgers	1898		
			6	TB5	Winslow	1897		
	Porter	2	7	TB6	Porter	1897		165t, 53.5x5.4x1.4m, 3b,2vqe, 3200hp, 27.5kts, 24p; 4x1-37/40, 3x1-450TT
			8	TB7	DuPont	1897		
	Morris	1	9	TB14	Morris	1898		105t, 42.5x4.7x1.2m, 2b,2vte, 1750hp, 23kts, 26p; 3x1-37/40, 3x1-450TT
	Talbot	2	10, 11	TB15, 16	Talbot, Gwin	1898	No picture	46t, 30.5x3.8x1.0m, 1b,1vte, 850hp, 20kts, 12p; 1x1-37/40, 2x1-450TT
	MacKenzie	2	12, 13	TB17, 18	MacKenzie, McKee	1898-1899	No picture	65t, 30.9x3.9x1.3m, 2b,1vte, 850hp, 20kts, 12p; 1x1-37/40(13), 2x1-37/40(14), 2x1-450TT
	Somers	1	14	TB22	Somers	1898	No picture	143t, 47.6x5.3x1.8m, 1b,1vqe, 1700hp, 23kts, 24p; 4x1-37/40, (1+2x1)-450TT
	Rowan	1	15	TB8	Rowan	1899		182t, 51.8x5.2x1.8m, 3b,2vqe, 3200hp, 26kts, 24p; 4x1-37/40, 3x1-450TT
	Davis	2	16	TB12	Davis	1899		155t, 45.1x4.7x1.8m, 2b,2vte, 1750hp, 23kts, 24p; 3x1-37/40, 3x1-450TT
			17	TB13	Fox	1899		
	Dahlgren	2	18	TB9	Dahlgren	1900		146t, 46.1x5.0x1.4m, 2b,2vte, 4200hp, 31kts, 29p; 4x1-37/40, 2x1-450TT
			19	TB10	Craven	1900		
	Bagley	3	20	TB24	Bagley	1901	No picture	168t, 47.9x5.2x1.5m, 2b,2vte, 4200hp, 28kts, 29p; 3x1-37/40, 3x1-450TT
			21	TB25	Barney	1901		
22			TB26	Biddle	1901			
Shubrick	3	23	TB31	Shubrick	1901		200t, 53.4x5.4x1.9m, 3b,2vte, 3375hp, 26(23)-25(24,25)kts, 28(23)-29(24,25)p; 3x1-47/45(24,25), 3x1-37/40(23), 3x1-450TT	
		24	TB32	Stockton	1901			
		25	TB33	Thornton	1902			
Blakely	2	26	TB27	Blakely	1904		196t, 53.4x5.2x1.8m, 3b,2vte, 3000hp, 26kts, 28-29p; 3x1-37/40, 3x1-450TT	
		27	TB28	De Long	1902			
Wilkes	1	28	TB35	Wilkes	1902		175t, 53.4x5.4x1.4m, 3b,2vte, 3000hp, 27kts, 29p; 3x1-37/40, 3x1-450TT	
Tingey	1	29	TB34	Tingey	1904		165t, 53.4x5.4x1.4m, 3b,2vte, 3000hp, 25kts, 29p; 3x1-37/40, 3x1-450TT	



SUBMARINES





SS	A	1	1	SS1	Holland	1900		64/74t, 16.4x3.1x2.6m, 1pe/em, 45/50hp, 8/5kts, 7p, 25m; 1x1-203/40pneumatic, 1-450TT
		2	SS2	Plunger	1903		107/123t, 19.5x3.6x3.2m, 1pe/em, 160/150hp, 8/7kts, 7p, 25m; 1-450TT	
		3	SS3	Adder	1903			
		4	SS4	Grampus	1903			
		5	SS5	Moccasin	1903			
		6	SS6	Pike	1903			
		7	SS7	Porpoise	1903			
		8	SS8	Shark	1903			

ESCORTS

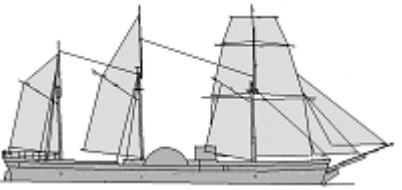
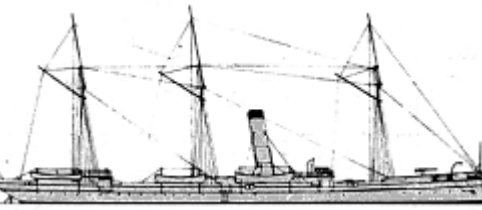
AY	-	9	1	Mayflower	1896	2690t, 83.2x11.0x5.3m, 2vte, 4700hp, 16.8kts; 2x1-127/40, 12x1-57/40
			2	Dorothea	1897	594t
			3	Eagle	1890	850t
			4	Gloucester	1891	786t
			5	Hawk	1891	545t
			6	Hornet	1890	425t
			7	Scorpion	1896	850t
			8	Vixen	1896	806t
			9	Wasp	1898	630t

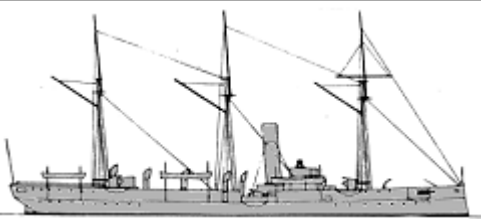
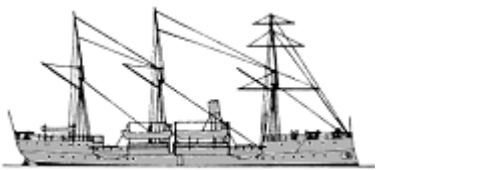
OTHER FIGHTING SHIPS

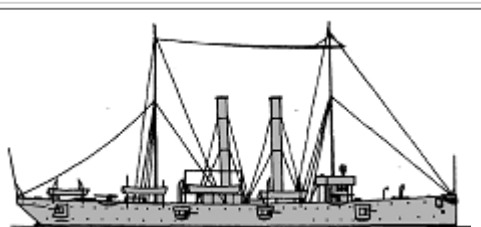
	Michigan	1	1	Michigan	1844		686t, 49.5ppx8.2x3.7m, 1b,1dse(sw), 110hp, 12kts, 148p; 6x1-47/40
	Dolphin	1	2	Dolphin	1884		1486t, 78.2x9.8x4.4m, 4b,1vc, 2255hp, 16kts, 152p; 1x1-152/30, 2x1-57/40, 4x5-37/20
	Yorktown	3					1921t, 74.5x11.0x4.3m, 4b,2hte, 3400hp, 16kts, 187-201p; 51CT; 6x1-152/30(3), 6x1-152/35(4,5), 2x1-

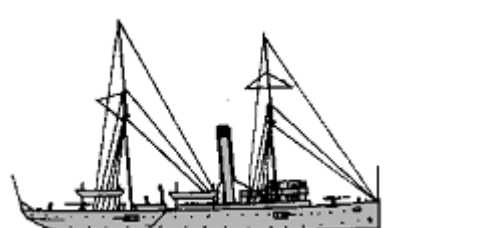
PG		5	PG4	Bennington	1891		57/40(3,4), 4x1-57/40(5), 2x1-47/40(3,4), 2x1-37/40(3,4), 4x1-37/40(5)	
	Petrel	1	6	PG2	Petrel	1889		867t, 57.3x9.4x3.5m, 4b,1hce, 1000hp, 11.4kts, 138p; 4x1-152/35, 2x1-47/40, 1x1-37/40, 2x5-37/20
	Bancroft	1	7		Bancroft	1893	No picture	839t, 57.6x9.8x3.7m, 2b,2vte, 1200hp, 14.5kts, 148p; 4x1-102/40, 8x1-47/40, 1x1-37/40
	Machias	2	8	PG5	Machias	1893		1318t, 62.2x9.8x3.7m, 2b,2vte, 1900hp, 15.5kts, 154p; 8x1-102/40, 4x1-57/50(8), 6x1-57/50(9), 4x1-37/40
			9	PG6	Castine	1894		
	Nashville	1	10	PG7	Nashville	1897		1719t, 71.2x11.6x3.4m, 2b,2vqe, 2530hp, 16.3kts, 180p; 64sponsons; 8x1-102/40, 4x1-57/50, 2x1-37/40
	Wilmington	2	11	PG8	Wilmington	1897		1689t, 76.4x12.5x2.7m, 6b,2vte, 1900hp, 15kts, 183-199p; 25belt, 38deck, 8x1-102/40, 4x1-57/50, 4x1-37/40
			12	PG9	Helena	1897		
	Annapolis	4	13	PG10	Annapolis	1897	No picture	1000-1153t, 62.3x11.0x3.7-3.9m, 2b,1vte, 1000hp, 11-13kts, 135-156p; 6x1-102/40, 4x1-57/50, 2x1-37/40
			14	PG11	Vicksburgh	1897		
			15	PG12	Newport	1897		
			16	PG13	Princeton	1898		
	Wheeling	2	17	PG14	Wheeling	1897		1170t, 57.8x10.4x3.7m, 2b,2vte, 1050hp, 13kts, 140p; 6x1-102/40, 4x1-57/50, 2x1-37/40
			18	PG15	Marietta	1897		
	Alvorado	2	19		Alvorado	1895	No picture	106t, 33.6x4.7x1.6m, 1b,1vc, 137hp, 12kts, 33p; 1x1-57/50(19), 2x1-47/45(20), 1x1-37/40(19)
20				Sandoval (TS)	1895			
Callao	4	21		Callao	1889	No picture	243t, 34.8x5.3x2.0m, 1b,2vc, 275hp, 10-10.5kts, 35p; 1x1-57/50(22-24), 4x1-47/45(21), 3x1-47/45(22,23), 1x1-47/45(24), 2x1-37/40(21,23,24)	
		22		Pampanga	1889			
		23		Paragua	1889			

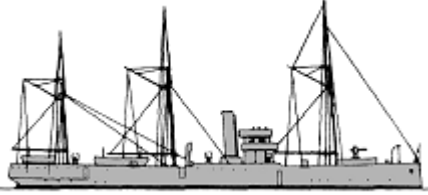
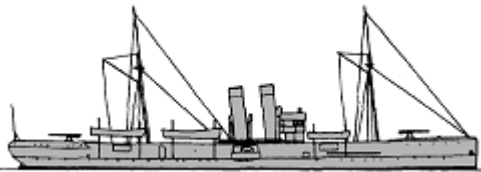
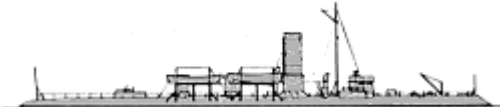
			24	Samar	1888		
Albay	3		25	Albay	1886	No picture	173t, 30.0x5.0x2.2m, 1b,2vc, 150(25)-120(26,27)hp, 9(25)-7.5(26)-8(27)kts, 35p; 1x1-57/50(25,27), 1x1-47/45(26), 2x1-37/40
			26	Calamianes	1888		
			27	Leyte	1890		
			28	Manileno	1885		
Manileno	4		29	Mariveles	1886	No picture	1x1-57/50(28,31), 1x1-47/45(29,30), 2x1-37/40(28,29,31), 1x1-37/40(30)
			30	Mindoro	1886		
			31	Panay	1886		
			32	Arayat	1888		
Arayat	1		32	Arayat	1888	No picture	243t, 34.6x5.3x2.0m, 1b,2vc, 10kts, 35p; 1x1-57/50, 1x1-47/45
Isla de Luzon	2		33	Isla de Luzon	1887		1020(33)-950(34)t, 59.4(33)-60.0(34)x9.1x3.4(33)-3.2(34)m, 2b,2hte, 535(33)-800(34)hp, 11.2(33)-13(34)kts, 137p; 4x1-102/40, 4x1-57/50, 3-356TT
			34	Isla de Cuba	1887		
Don Juan de Austria	1		35	Don Juan de Austria	1889		1015t, 65.7x9.8x3.8m, 4b,1hc, 1200hp, 12kts, 153p; 4x1-127/40, 4x1-57/50
Quiros	2		36	Quiros	1897	No picture	350-370t, 44.2x6.9x2.4m, 2b,1vte, 450hp, 11kts, 44-57p; 2x1-57/50, 2x1-47/45, 2x1-37/40(37)
			37	Villalobos	1896		
Elcano	1		38	Elcano	1885	No picture	620t, 50.4x7.9x3.1m, 2b,2vc, 1200hp, 11kts, 103p; 4x1-102/40, 4x1-57/50
APG -	1	1	PG35	Topeka	1881		2372t, 76.2x10.7x5.4m, 4b,2hce, 2200hp, 16kts; 8x1-102/40, 2x1-57/50, 4x1-47/45, 2x1-37/40
RAM	Katahdin	1	1	Katahdin	1896		2383t, 76.4wlx13.2x4.6m, 3b,2hte, 5068hp, 16kts, 97p; Harvey: 152side, 152deck, 457CT; 4x1-57/45

COAST GUARD CUTTERS

Grant	1	1		U. S. Grant	1872	No picture	350t, 49.7x7.6x3.5m, 1b,1vte, 45p; 4x1-
Manhattan	1	2		Manhattan	1873	No picture	147t, 31.1x6.2x2.6m, 1vce, 16p; 1x1-57/40
Dallas	3		3	Dallas	1874	No picture	188(3,4)-300(5)t, 42.7(3,4)-53.4(5)x6.5(3,4)-7.9(5)x3.3(3,4)-3.8(5)m, 1b,1seidae(3,4)-1b,1vce(5), 275(3,4)-400(5)hp, 9.5kts, 40p; 2x1-57/40(3,4), 3x1-57/40(5)
			4	Dexter	1874		
			5	Rush	1874		
Walter Forward	1	6		Walter Forward	1882	No picture	267t, 47.3x7.6x2.3m, 2vce, 38p; 2x1-
Fessenden	1	7		Fessenden	1883	No picture	330t, 58.5x8.5x2.4m, 1vce(sw), 40p; 4x1-

CGC	Commodore Perry	1	8		Commodore Perry	1884	No picture	282t, 50.3x7.6x3.4m, 1hdase, 41p; 2x1-
	Bear	1	9		Bear	1874	No picture	703t, 60.5x9.2x5.5m, 1b,1vce, 51p; 3x1-57/40
	Lot M. Morrill	1	10		Lot M. Morrill	1889	No picture	288t, 44.3x7.3x2.9m, 1b,1vce, 13kts, 38p; 1x1-76/50, 2x1-57/40
	Winona	1	11		Winona	1890	No picture	321t, 45.3x8.0x1.8m, 2vce, 600hp, 39p; 1x1-
	Galveston	1	12		Apache	1891	No picture	708t, 57.9x8.8x2.8m, 2b,2vce, 1200hp, 12kts, 41p; 4x1-57/40
	William Windom	1	13		William Windom	1896	No picture	670t, 52.0x8.2x2.9m, 2b,2vte, 800hp, 15kts, 49p; 3x1-47/40
	Gresham	4	14	CG1	Gresham	1897	No picture	1190t, 62.6x9.8x3.4m, 4b,1vte, 2500hp, 17kts, 73p; 4x1-57/40
			15	CG2	Manning	1898		
			16	CG4	Algonquin	1898		
			17	CG5	Onondaga	1898		
	McCulloch	1	18		McCulloch	1897	No picture	1280t, 66.8x10.2x4.3m, 2b,1vte, 17kts, 130p; 4x1-76/50, 1-450TT
	Thetis	1	19		Thetis	1881	No picture	1250t, 57.5x8.9x5.4m, 1vce; 3x1-47/40
	Seminole	1	20		Seminole	1900	No picture	860t, 57.3x8.8x3.4m, 2b,1vte, 14.7kts, 67p; 4x1-57/40
Tuscarora	1	21		Tuscarora	1902	No picture	739t, 54.3x9.1x3.4m, 2b,1vte, 14.2kts, 65p; 1x1-57/45	
Mohawk	1	22		Mohawk	1904	No picture	980t, 62.7x9.8x3.8m, 1vte, 71p; 2x1-57/40	

[home](#)[World navies yesterday](#)[1905](#)

Uruguay 01 January 1905

OTHER FIGHTING SHIPS

PG	General Artigas	1	1	General Artigas	1883	No picture	270t, 39.0x6.3x2.6m, 1hc, 520hp, 12.5kts; 2x1-120/27
	Malvinas	1	2	Malvinas	1885	No picture	400t, 43.0x7.0x3.1m, 280hp, 8kts; 2x1-small guns
	General Suárez	1	3	General Suárez	1864	No picture	405t, 38.8x6.7x3.0m, 205hp, 9kts, 62p; 4x1-79/27
PGR	Maldonado	1	1	Maldonado	1886	No picture	300t, (stw), 12kts; 4x1-small guns

© Ivan Gogin, 2015

[home](#)[World navies yesterday](#)[1905](#)

Venezuela 01 January 1905

TORPEDO SHIPS

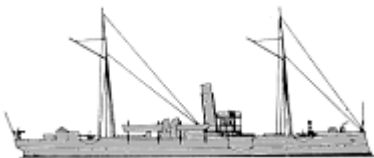
PGT	Bolívar	1	1	Bolívar	1894		630t, 58.0ppx6.7x3.2m, 4b,2vte, 2600hp, 19kts, 91p; steel- 13deck; 2x1-120/35, 4x1-57/42, 1x4-25/42, 2x1-356TT
-----	---------	---	---	---------	------	---	--

OTHER FIGHTING SHIPS

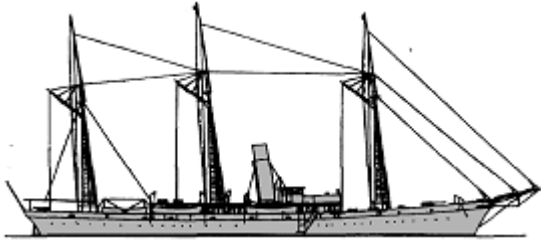
PG	Miranda	1	1	Miranda	1895	No picture	200t, 41.5x5.8x2.5m, 1b,1vte, 315hp, 10kts, 55p; 4x1-57/42
APG	-	2	1	Restaurador	1884		750t; 1x1-76/40
			2	Jose Felix Ribas	1894		300t

© Ivan Gogin, 2015