

[home](#)

THE NAVAL BALANCE 1900

Navies of the world

01/01/1900

1. United Kingdom - 1324 tt; 2. France - 565 tt; 3. Russia - 354 tt; 4. Germany - 298 tt; 5. USA - 295 tt; 6. Italy - 272 tt; 7. Japan - 148 tt; 8 - Austria-Hungary - 112 tt

tt - thousand ton

[Argentina](#)

[Australia](#)

[Austria-Hungary](#)

[Belgium](#)

[Brazil](#)

[Bulgaria](#)

[Cambodia](#)

[Chile](#)

[China](#)

[Colombia](#)

[Costa Rica](#)

[Cuba](#)

[Denmark](#)



[Dominican Republic](#)

[Ecuador](#)

[Egypt](#)

[El Salvador](#)

[France](#)

[Germany](#)

[Greece](#)

[Haiti](#)

[Honduras](#)

[India](#)

[Italy](#)

[Japan](#)

[Mexico](#)

[Morocco](#)

[Netherlands](#)

[New Zealand](#)

[Norway](#)

[Ottoman Empire](#)

[Persia](#)

[Peru](#)

[Portugal](#)

[Romania](#)

[Russia](#)

[Sarawak](#)

[Siam](#)

[Spain](#)

[Sweden](#)

[United Kingdom](#)

[United States of America](#)

[Uruguay](#)

[Venezuela](#)

1576463

[Website Hit Counter](#)

© Ivan Gogin, 2015



[home](#)[World navies yesterday](#)[1900](#)

Argentina 01 January 1900

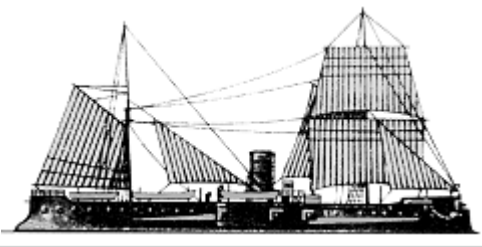
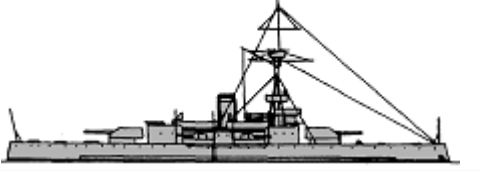
BATTLESHIPS



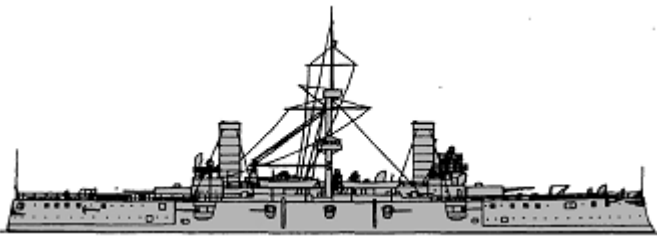

	El Plata	1	El Plata	1875		1500t, 56.7x13.4x3.2m, 4b,2vc, 750hp, 9.5kts, 126p; iron- 152belt, 30deck, 229turret; 1x2-203/30, 2x1-120/40, 2x1-57/40, 4x1-25/42
		2	Los Andes	1875		
BC	Almirante Brown	1	Almirante Brown	1882		4200t, 73.2ppx15.2x6.3m, 8b,2vc, 5400hp, 14kts, 520p; compound- 229belt, 203battery, 203CT; 10x1-150/50, 6x1-120/50, 2x1-47/40, 2-450TT
	Libertad	4	Libertad	1892		2595t, 70.1ppx13.1x4.0m, 4b,2vte, 2780hp, 14.2kts, 230p; steel- 203belt, 37deck, 203barbettes, 102CT; 2x1-238/32, 4x1-120/41, 4x1-47/42, 2-450TT
		5	Independencia	1892		

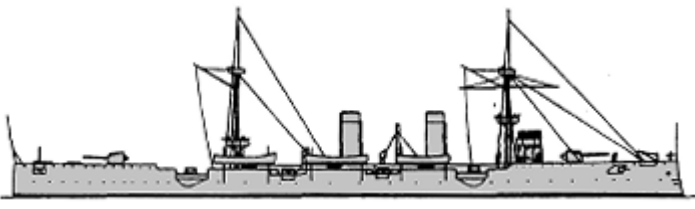
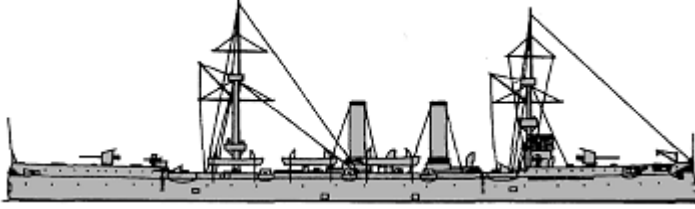
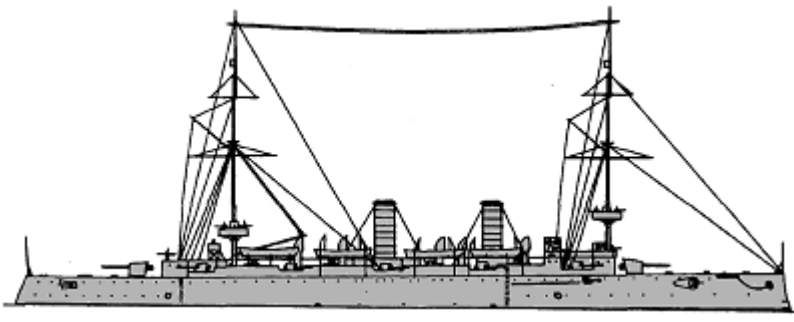
CRUISERS

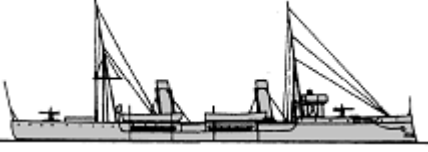

CA	Garibaldi	1	Garibaldi	1896		6775t, 111.7x18.2x7.1m, 8b,2vte(1-3)-16b,2vte(4), 13000hp, 20kts, 500-540p; Harvey(1-3)- 150belt, 150turrets, 37deck, 150CT; 2x1-254/40(1,3,4), 2x2-203/45(2), 10x1-152/40(1,2), 14x1-152/40(3,4), 6x1-120/41(1,2), 2x1-76/40(3,4), 10x1-57/40, 10x1-37/20(1,2), 12x1-37/20(3,4)
		2	San Martin	1898		
		3	General Belgrano	1898		
		4	Pueyrredon	1898		
	Patagonia	1	Patagonia	1887		1530t, 64.9ppx10.0x3.9m, 2b,2hc, 2730hp, 14kts, 140p; steel- 102shield, 32deck, 38CT; 1x1-254/33, 3x1-152/31, 4x1-76/26
	Veinticinco	1	Veinticinco	1891		3500t, 107.9x13.4x4.9m, 4b,2vte, 14050hp, 22.4kts, 320p; steel- 114slopes, 89deck, 51shields,

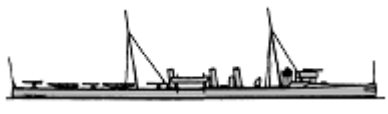
								102CT; 1x1-209/32, 8x1-120/37, 12x1-47/37, (1+2x1)-450TT
CL	Nueve de Julio	1 3	Nueve de Julio	1893				3600t, 113.5x13.4x5.0m, 8b,2vte, 14500hp, 22.2kts, 327p; steel- 114slopes, 89deck, 51shields, 102CT; 4x1-152/40, 8x1-120/41, 12x1-47/40, 5-450TT
	Buenos Aires	1 4	Buenos Aires	1896				4788t, 129.2x12.9x5.6m, 8b,2vte, 17000hp, 24kts, 350p; steel- 127slopes, 38deck, 114shields, 152CT; 2x1-203/45, 4x1-152/45, 6x1-120/44, 16x1-47/40, 5-450TT

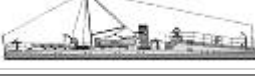
TORPEDO SHIPS

	Maipú	1 1	Maipú	1881	No picture		1063t, 82.4x9.2x2.7m, sw, 14kts, 90p; 1x1-121/21, 2-356TC
PGT	Espora	1 2	Espora	1890			520t, 64.0x7.6x2.5m, 4b,2vte, 3420hp, 19.4kts, 47p; 2x1-76/46, 1x1-63/42, 2x1-47/42, (1+2x2)-450TT
	Patria	1 3	Patria	1894			1029t, 76.7x9.6x3.0m, 4b,2vte, 5000hp, 20.5kts, 100p; 2x1-120/41, 4x1-63/42, 2x1-47/42, 5-450TT
DD	Corrientes	1	Corrientes	1898			280t, 57.9x5.9x2.2m, 6b,2vte, 4200hp, 27kts, 54p; 1x1-76/46, 3x1-57/42, (1+2x1)-450TT
		2	Entre Rios	1896			
		3	Misiones	1897			
TB	Ferré	4 1-4	Ferré, Enrique Py, Centella, Alerta	1880-1882			52t, 30.5x3.8x1.8m, 1b,1vc, 500hp, 18.5-20kts, 11p; 2x4-25/42, 2-356TT
	Nr.1	2 5, 6	Nr.1, 2	1881	No picture		17t, 18.4x2.3x1.1m, 1b,1vc, 230hp, 16kts, 10p; 1spar torpedo
	Nr.1	8 7-14	Nr.1-8	1890			16t, 18.3x2.8x1.1m, 1b,1vte, 230-250hp, 17-18kts, 10p; 1x1-47/42, 1x1-356TT
	Bouchard	6 15-20	Bouchard, Bathurst, Jorge, King, Pinedo, Thorne	1890-1892			90t, 39.6ppx4.3x1.8m, 2b,2vte(15,17-20)-2b,1vqe(16), 1110(15,17-20)-1230(16)hp, 23.5(15,17-20)-24.4(16)kts, 15p; 2x1-47/42, 1x4-25/42, (1+1x2)-450TT
	Comodoro Py	2 21	Comodoro Py	1892	No picture		110t, 45.7x4.4x1.1m, 2b,1vte, 1800hp, 25kts, 27p; 2x1-47/42, 1x4-25/42, (1+1x2+1x1)-450TT

OTHER FIGHTING SHIPS

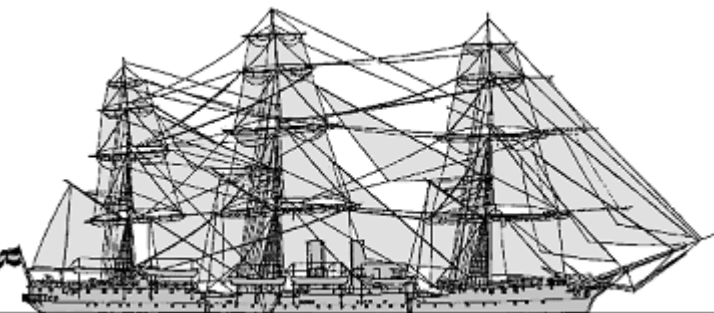
PG	Paraná	1	Paraná	1874		515t, 46.3ppx7.6x3.0m, 2b,1hc, 475hp, 11kts, 100p; 2x1-120/41, 2x1-63/42
		2	Uruguay	1874		
	Pilcomayo	3	República	1876		
		4	Constitución	1876		
CT	Presidente Sarmiento	1	Presidente Sarmiento	1898		2733t, 85.5ppx13.3x5.9m, 4b,2vc, 1800hp, 13kts, 305+40p, 4x1-120/43, 6x1-57/42, 2x1-37/27, 3-356TT

© Ivan Gogin, 2015



[home](#)[World navies yesterday](#)[1900](#)

Australia 01 January 1900

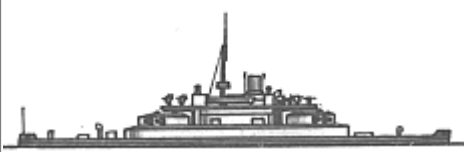
BATTLESHIPS

MON	Cerberus	1	1	Cerberus	1870		3344t, 68.6ppx13.7x4.7m, 2hrccr, 1360(1)-1436(2)hp, 9.8(1)-10.7(2)kts, 155p; iron: 203belt, 38deck, 254turrets; 2x2-254/15MLR(1), 2x2-203/30(2)
-----	----------	---	---	----------	------	--	---

TORPEDO SHIPS

PGT	Sharpshooter	1		Boomerang	1891		735t, 70.1ppx8.2x3.2m, 4b,2vte, 3600hp, 19kts, 91p; 2x1-120/40, 4x1-47/40, (1+2x2)-356TT
		2	2	Karakatta	1891		
TB	Childers	1	1	Childers	1884	No picture	61t, 35.5x3.8x1.7m, 1b,1hce, 679hp, 18kts, 18p; 2x1-37/30, 2-381TT
	Countess of Hopetown	1	2	Countess of Hopetown	1890		82t, 36.6x4.1xm, 1b,1vte, 1150hp, 23kts, 19p; 3x1-47/40, (2+1x1)-356TT
TB2cl	Gordon	1	1	Gordon	1886	No picture	12t, 17.1x2.9x1.5m, 1b,1csce, 150hp, 15kts, 11p; 3x1-25/40, 2-356TC
	Midge	1	2	Midge	1888	No picture	12t, 17.2x2.8x1.4m, 1b,1hce, hp, kts, p; 2x2-25/40, 1spar torpedo
	Acheron	2	3, 4	Acheron, Avernus	1879		16t, 23.8x3.1x0.9m, 1b,1hce, 200hp, 15kts, 9p; 2-356TC
	Defender	4	5 - 8	Nepean, Lonsdale, No191, Mosquito	1883 - 1884		12t, 19.2ppx2.3x1.2m, 1b,1hce, 17kts, 7p; 1x2-25/40, 1-356TT

OTHER FIGHTING SHIPS

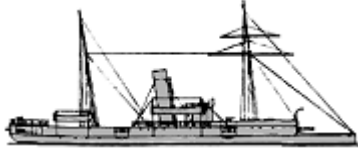
PG	Protector	1	1	Protector	1884		920t, 57.3x9.1x3.8m, 4b,2vce, 1500hp, 14kts, 90p; 1x1-203/26, 5x1-152/31, 4x1-47/40, 5x1-11.4
	Paluma	2	2	Paluma	1884	No picture	360t, 36.6x7.9x2.9m, 1b,2vce, 400hp, 10.5kts, p; 1x1-203/26(54), 1x1-152/31, 2x1-37/30, 2x1-11.4
3		3	Gayundah	1884			

[home](#)[World navies yesterday](#)[1900](#)

Austria-Hungary 01 January 1900

BATTLESHIPS

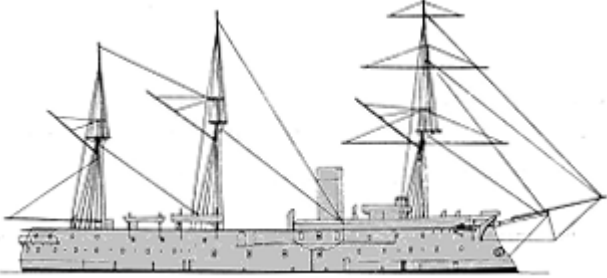
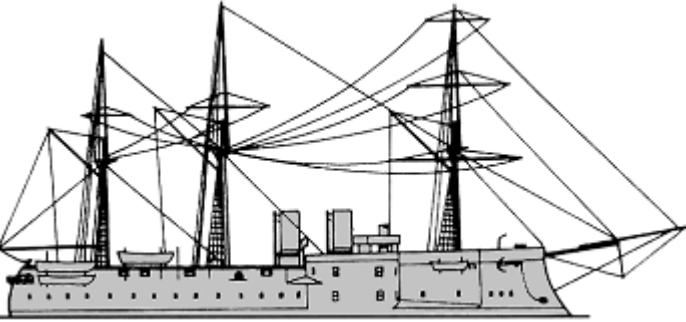
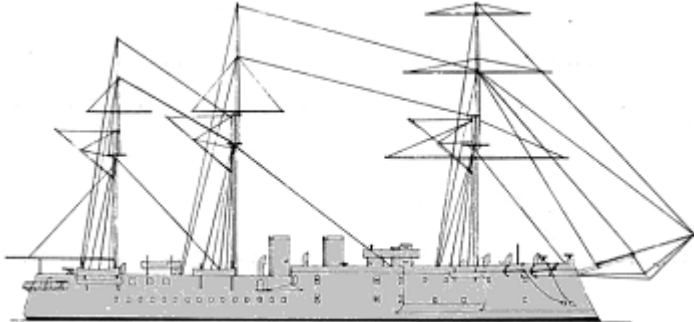
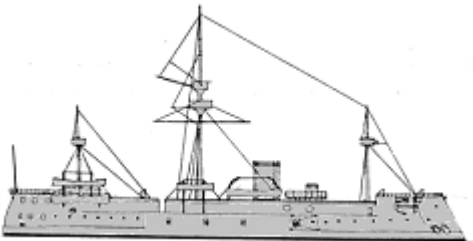

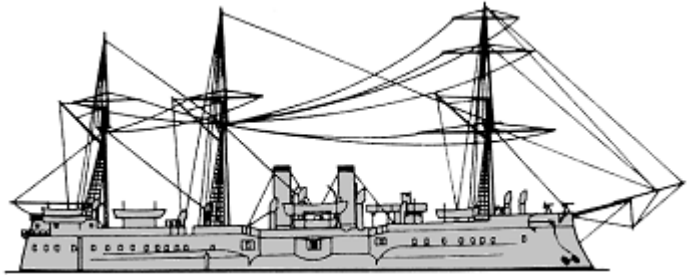
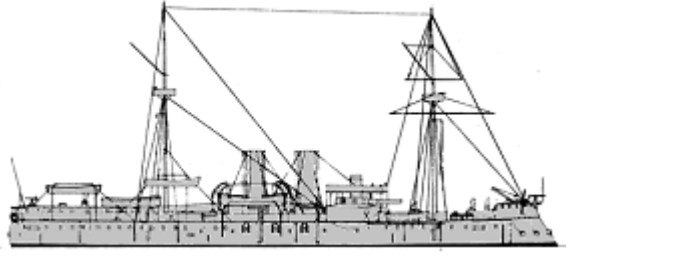
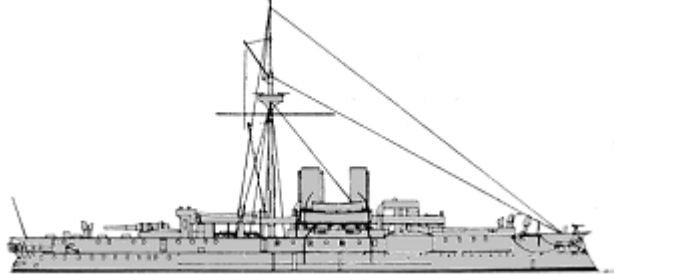
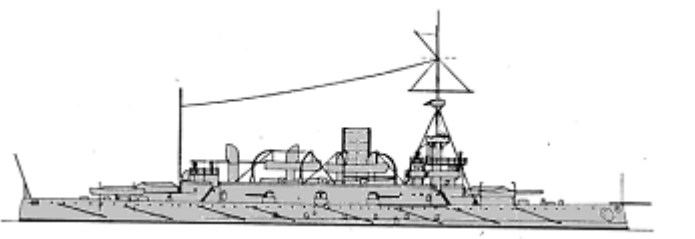
						5720t, 77.8x17.8x7.4m, 4b,2hr cr, 2786hp, 11.5kts, 471p; iron- 152belt, 140casemates, 18deck; 10x1-229/15, 6x1-87/22, 2x1-66/16, 4x1-47/30, 3x5-47/22, 4x5-25/41, 3-356TT
						5980t, 89.7x17.2x6.7m, 8b,1hr cr, 3969hp, 12.8kts, 540p; iron- 205belt, 175casemates; 8x1-235/20, 6x1-87/22, 2x1-66/16, 4x1-47/30, 5x5-47/22, 2x5-25/41, 4-356TT
						7731t, 95.0x17.7x7.9m, 8b,1hr cr, 4158hp, 13.7kts, 548p; iron- 230belt, 175casemates; 8x1-263/20, 6x1-87/22, 2x1-66/16, 4x1-47/30, 5x5-47/22, 2x5-25/41, 4-356TT
		4	Kaiser Max	1876		3548t, 75.9x15.3x6.2m, 4b,1hr cr, 2755hp, 13.3kts, 400p; iron- 205belt, 125casemate; 8x1-209/18, 4x1-87/22, 2x1-66/16, 6x1-47/30, 3x5-47/22, 2x5-25/41, 4-356TT
		5	Don Juan d'Austria	1876		
		6	Prinz Eugen	1878		
BB		3	Kaiser Max			

		1	7	Tegetthoff	1881		7431t, 89.4x21.8x7.6m, 8b,2vte, 8160hp, 15.3kts, 575p; iron- 370belt, 40deck, 370casemates, 175CT; 6x1-235/32, 5x1-149/33, 2x1-66/16, 9x1-47/40, 6x1-47/30, 2-356TT
		1	8	Kronprinzessin Erzherzogin Stefanie	1889		5075t, 87.2x17.1x6.6m, 10b,2vc, 8000hp, 17kts, 430p; compound- 230belt, 25deck, 280turrets, 50CT; 2x1-305/32, 6x1-149/33, 2x1-66/16, 7x1-47/40, 2x1-47/30, 2x1-37/20, 4-400TT
		1	9	Kronprinz Erzherzog Rudolf	1889		6829t, 97.6x19.3x7.4m, 10b,2vc, 6000hp, 15.5kts, 447p; Harvey- 305belt, 70deck, 250turrets, 75CT; 3x1-305/32, 6x1-120/31, 2x1-66/16, 5x1-47/40, 2x1-47/30, 2x1-37/20, 4-400TT
	Monarch	3	10	Monarch	1898		5645(10,12)-5636(11)t, 99.2x17.0x6.4m, 7b,2vte(10,11)-16b,2vte(12), 8500hp, 17.5kts, 426p; NS- 270belt, 40deck, 250turrets, 250CT; 2x2-238/37, 6x1-149/37, 2x1-66/16, 10x1-47/40, 4x1-47/30, 2-450TT
	11		Wien	1898			
	12		Budapest	1898			

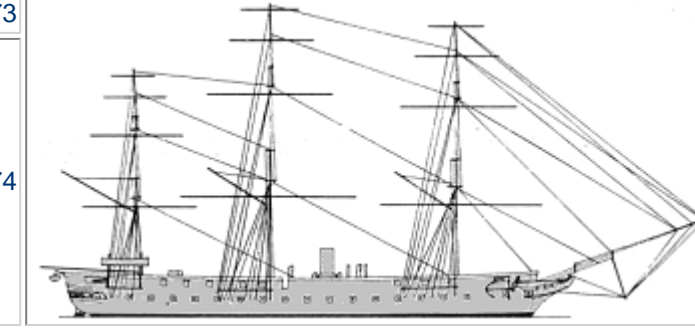

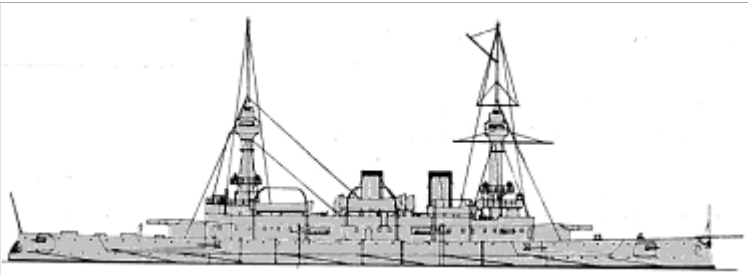
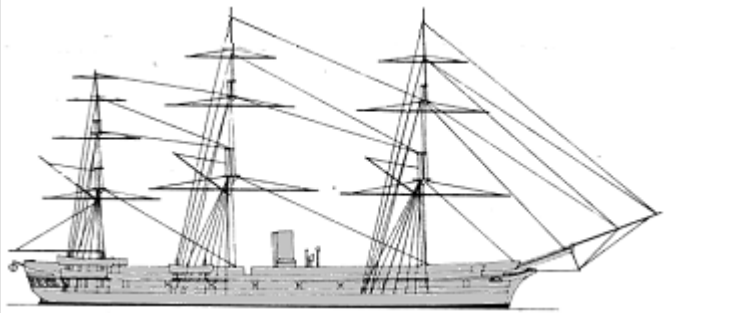
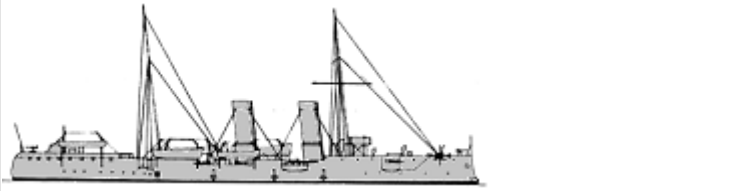
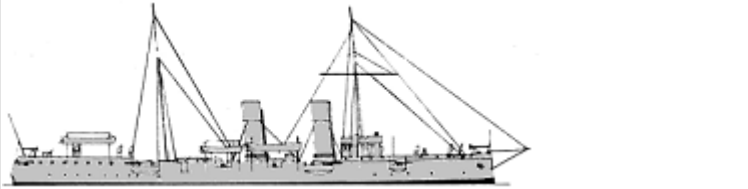
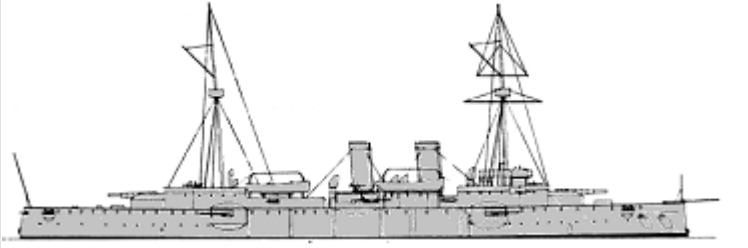
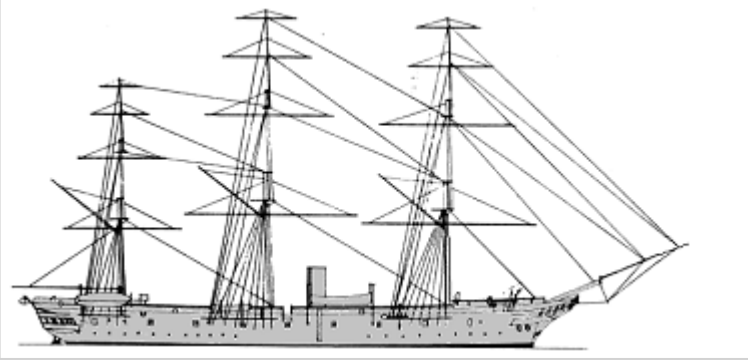

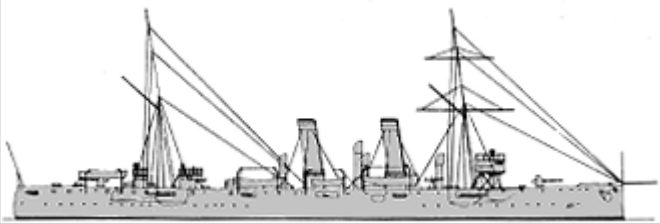
CRUISERS





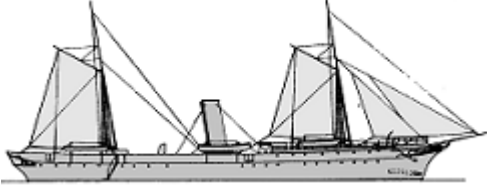
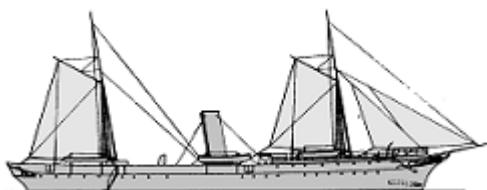
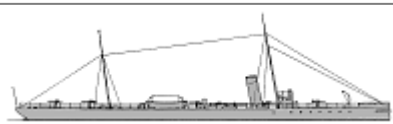



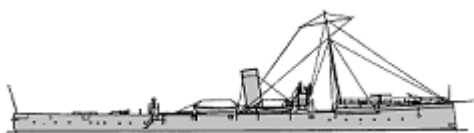





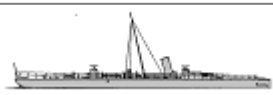

CA	Radetzky	1	Radetzky	1873		3956t, 79.1x14.3x7.0m, 4b,1hse, 3385(1)-2500(2)hp, 13.4(1)-13.2(2)kts, 450p; 15x1-149/24, 2x1-66/16, 4x1-47/30, 3x5-47/22, 3-356TT	
		2	Laudon	1874			
	Kaiserin und Königin Maria Theresia	1	3	Kaiserin und Königin Maria Theresia	1894		6026t, 113.7x16.3x6.8m, 10b,2hte, 9000hp, 19kts, 475p; Harvey- 100belt, 60deck, 100turrets, 50CT; 2x1-238/32, 8x1-149/33, 2x1-66/16, 12x1-47/40, 6x1-47/30, 4-450TT

						
	Saida	1	1 Saida	1879		2662t, 79.4x13.1x5.8m, 4b,1hse, 1790hp, 12kts, 359p; 11x1-149/24, 1x1-66/16, 2x5-25/41
	Panther	2	Panther	1885		1557t, 73.2x10.4x4.3m, 6b,2vc, 5940(2)-6380(3)hp, 18.4(2)-18.7(3)kts, 186p; steel- 12deck; 2x1-120/31, 4x1-47/40, 6x5-47/22, 4-356TT
		3	Leopard	1886		
	Tiger	1	4 Tiger	1888		1657t, 76.0x10.6x4.3m, 6b,2vc, 5700hp, 18.6kts, 188p; steel- 12deck; 4x1-120/31, 6x1-47/40, 4x5-47/22, 4-356TT
CL	Kaiser Franz Joseph I	5	Kaiser Franz Joseph I	1890		4494t, 103.7x14.8x5.7m, 10b,2hte, 8450hp, 19kts, 367p; steel- 57hull, 38deck, 90barbettes, 50CT; 2x1-238/32, 6x1-149/33, 2x1-66/16, 5x1-47/40, 4x1-47/30, 3x1-37/20, 4-400TT
		6	Kaiserin Elisabeth	1892		
	Donau	1	7 Donau	1894		2306t, 70.0x12.8x5.6m, 4b,1vc, 1300hp, 10kts, 333p; 10x1-120/31, 1x1-66/16, 4x5-25/41
						2503t, 96.9x11.7x4.2m, 8b,2vte, 8160hp, 20.8kts, 308p; steel- 50slopes, 40deck,

	Zenta	1	8	Zenta	1899		35casemates, 50CT; 8x1-120/37, 8x1-47/40, 2x1-47/30, 2-450TT
CLL	Zrinyi	3	1	Zrinyi	1871		1353t, 69.1x10.5x5.0m, 2b,1hse, 1000(1,2)-1165(3)hp, 11(1,2)-11.2(3)kts, 210p; 2x1-149/18, 4x1-87/22, 2x1-66/16, 2x5-47/22
			2	Fruntsberg	1873		
			3	Aurora	1874		

TORPEDO SHIPS



PGT	Zara	2	1	Zara	1881		852t, 67.2x8.2x3.7m, 5b,2vc, 2600hp, 14.3kts, 148p; 4x1-87/22, 1x1-66/16, 4x1-47/30, 1x5-47/22, 2x5-25/41, (2+2x1)-356TT
			2	Spalato	1880		
	Sebenico	1	3	Sebenico	1882		890t, 69.7x8.2x3.4m, 4b,2vc, 1344hp, 12.8kts, 135p; 4x1-87/22, 1x1-66/16, 2x5-25/41, 1-356TT
	Blitz	2	4	Blitz	1888		426t, 59.0ppx6.9x2.1m, 2b,1vte, 2600hp, 21kts, 61p; 8x1-47/40, (1+1x1)-450TT(5), (1+1x1)-356TT(4)
			5	Komet	1889		
	Meteor	1	6	Meteor	1889		436t, 57.0ppx6.8x2.6m, 2b,1vte, 2600hp, 21kts, 60p; 9x1-47/30, (1+1x1)-450TT
	Planet	1	7	Planet	1890		525t, 67.1x7.0x2.8m, 4b,2vte, 3500hp, 19.6kts, 84p; 2x1-66/37, 8x1-47/40, (1+1x1)-450TT
	Trabant	1	8	Trabant	1890		540t, 67.0x8.0x2.4m, 4b,2vte, 3800hp, 20.1kts, 84p; 2x1-66/37, 8x1-47/40, (1+1x1)-450TT
Satellit	1	9	Satellit	1893		616t, 68.9x8.1x2.4m, 4b,2vte, 4000hp, 23kts, 86p; 1x1-66/37, 6x1-47/40, (1+1x1)-450TT	

	Magnet	1	10	Magnet	1896		510t, 67.5ppx8.2x3.3m, 4b,2vte, 6000hp, 26kts, 80p; 6x1-47/40, 2x1-450TT
TB	I	1	1	I	1875		10t, 20.7x2.6x1.2m, 1b,1vse, 184hp, 18kts, 9p; 1x1-37/20
	II	1	2	II	1878		28t, 26.5x3.5x1.6m, 1b,1hc, 300hp, 18.2kts, 10p; 2-356TT
	III	2	3, 4	III, IV	1879		27t, 26.4x3.3x1.5m, 1b,1hc, 430hp, 17.5kts, 10p; 2-356TT
	V	4	5-8	V-VIII	1881		30t, 27.7x3.3x1.4m, 1b,1hc, 430hp, 18.3kts, 10p; 2-356TT
	IX	2	9, 10	IX, X	1881		47t, 31.2x3.7x1.6m, 1b,1vc, 500hp, 18kts, 15p; 1x1-37/20, 2-356TT
	XI	16	11-26	XI-XXVI	1883-1886		55t, 34.3x3.8x1.7m, 1b,1vc, 600hp, 18-19kts, 16p; 1x1-37/20, 2-356TT
	Adler	2	27	Adler	1886		100t, 41.2x4.2x1.7m, 2b,1vc, 1300hp, 22kts, 16p; 2x1-37/20, 2-356TT
			28	Falke	1886		
	Sperber	2	29, 30	Sperber, Habicht	1886		93t, 39.9x4.8x1.9m, 1b,1vte, 970hp, 18.5kts, 16p; 2x1-37/20, 2-356TT
	Bussard	20	31-50	Bussard, Condor, Geier, Uhu, Würger, Kranich, Reiher, Ibis, Rabe, Elster, Kukuk, Staar, Krähe, Flamingo, Sekretär, Weihe, Marabu, Gaukler, Harpie, Kibitz	1886-1891		88t, 39.9x4.8x1.9m, 1b,1vte, 1000hp, 19kts, 16p; 2x1-37/20, (1+1x1)-356TT
	XXVII	6	51-56	XXVII-XXXII	1886-1888		55t, 34.3x3.8x1.7m, 1b,1vc, 600hp, 18-19kts, 16p; 1x1-37/20, 2-356TT
	XXXIII	1	57	XXXIII	1887		70t, 36.8x4.5x1.9m, 1b,1vc, 700hp, 17kts, 16p; 2x1-37/20, 2-356TT
	XXXIV	6	58-63	XXXIV-XXXIX	1889-1891		64t, 36.9x4.8x1.9m, 1b,1vc, 750hp, 20.3kts, 16p; 2x1-37/20, (1+1x1)-356TT
	Natter	1	64	Natter	1896		166t, 47.3x5.3x2.8m, 2b,1vte, 2200hp, 24kts, 21p; 2x1-47/30, 3x1-450TT
Viper	1	65	Viper	1896		124t, 45.0x4.5x2.3m, 2b,1vte, 1900hp, 25kts, 21p; 2x1-47/30, 3x1-450TT	
Boa	3	66	Boa	1898		132t, 46.6x4.7x2.3m, 2b,1vte, 2000hp, 24.5kts, 21p; 2x1-47/30, 3x1-450TT	
		67	Cobra	1898			
		68	Python	1899			

ESCORTS

AY	-	1	1	Dalmat	1896	260t
----	---	---	---	--------	------	------

OTHER FIGHTING SHIPS

PG	Möwe	1	1	Möwe	1859	No picture	348t, 45.0x7.2x3.2m, sails, 48p; 2x1-160/14
	Kerka	1	2	Kerka	1861	No picture	540t, 45.0x8.0x3.6m, 1hse, 250hp, 9kts, 100p; 4x1-160/14, 2x1-149/14
	Dalmat	1	3	Hum	1861	No picture	869t, 53.0x8.7x3.7m, 1hse, 230hp, 11.5kts, 139p; 2x1-194/14, 2x1-149/14
	Albatros	2	4	Albatros	1874	No picture	570t, 46.0x8.3x3.4m, 400hp, 10kts, 99p; 2x1-149/24, 1x1-83/17
5			Nautilus	1874			
RMON	Leitha	2	1	Leitha	1872		315t, 50.6x8.1x1.1m, 2b,2vte, 700hp, 8kts, 59p; steel- 44side, 25deck, 50CT; 1x1-120/33, 2x1-47/40
			2	Maros	1872		
	Körös	2	3	Körös	1892		448t, 54.0x9.0x1.2m, 2b,2vte, 1200hp, 10kts, 72p; 50side, 19deck, 75(3)-50(4)CT; 2x1-120/31, 2x1-66/37
			4	Szamos	1892		

COASTAL FORCES

YPR	A	1	1	A	1895	No picture	33t, 22.0x3.5x1.1m, 200hp
-----	---	---	---	---	------	------------	---------------------------

MINE WARFARE SHIPS

ML	Dromedar	1	1	Dromedar	1891	No picture	175t, 32.0x5.4x1.9m, 1b,1vte, 350hp, 10kts, 25p; 2x1-47/30, 50mines
	Salamander	1	2	Salamander	1892	No picture	286t, 39.6x8.1x1.5m, 1b,1vte, 350hp, 10kts, 28p; 2x1-47/30, 90mines



[home](#)

[World navies yesterday](#)

[1900](#)

Belgium 01 January 1900

ESCORTS

FPV	Ville d'Anvers	1	1	Ville d'Anvers	1886	No picture	684t, 65.2x9.1x3.6m, 45p
-----	----------------	---	---	----------------	------	------------	--------------------------

© Ivan Gogin, 2015

[home](#)[World navies yesterday](#)[1900](#)

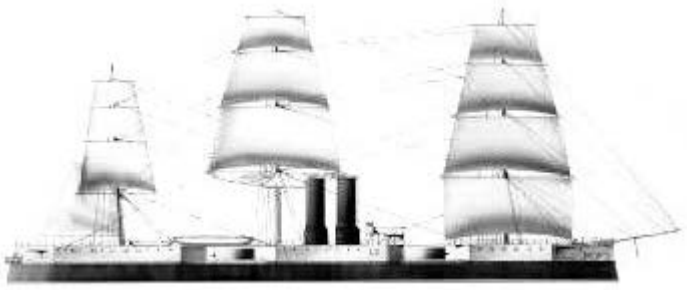
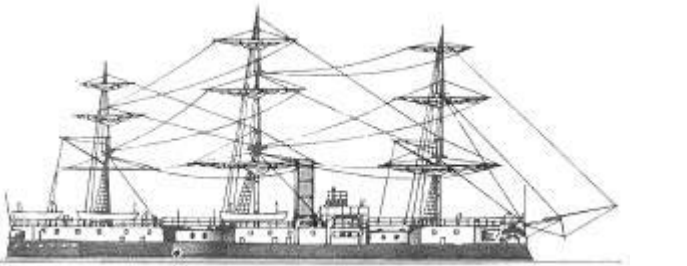

Brazil 01 January 1900

BATTLESHIPS



BB	Riachuelo	1	1	Riachuelo	1883		6100t, 93.0ppx15.9x6.0m, 10b,2vc, 7300hp, 16.7kts, 367p; compound- 292belt, 254turrets, 254CT; 2x2-234/31, 6x1-120/32, 6x1-47/40, 5-356TT
	Aquidabã	1	2	Vinte e Quatro de Maio	1887		4921t, 85.3x15.9x5.6m, 8b,2ic, 6500hp, 15.8kts, 277p; compound- 292belt, 254turrets, 254CT; 2x2-234/31, 4x1 - 120/40, 10x1-57/42, 5-356TT

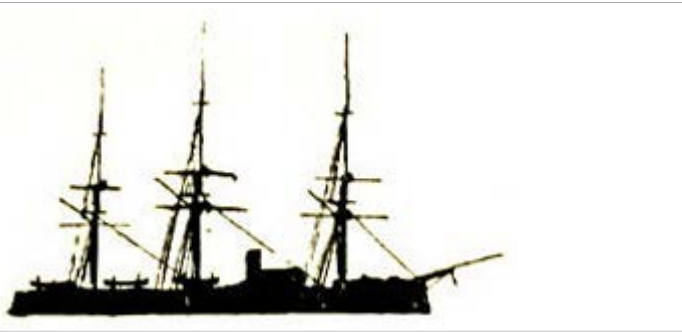

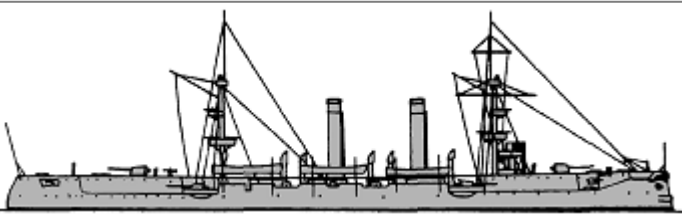
CRUISERS

CL	Niterói	1	1	Niterói	1864	No picture	1790t, 58.4x12.6x5.4m, 1hse, 1000hp, 7kts, 271p; 12x1-127/24
	Guanabara	1	2	Paysandú	1879	No picture	1914t, 61.0ppx12.6x5.4m, 1hse, 3000hp, 13kts, 287p; 9x1-127/24, 2x1-76/23, 1 spar torpedo
	Almirante Tamandaré	1	3	Almirante Tamandaré	1893		4735t, 89.7x14.4x6.0m, 7b,2hte, 7500hp, 17kts, 400p; steel- 40deck, 76casemates, 51CT; 10x1-152/40, 2x1-120/40, 10x1-47/40
	Benjamin Constant	1	4	Benjamin Constant	1894		2820t, 74.0x13.6x5.6m, 2vte, 4000hp, 15kts, 216+184p; 51deck, 95CT; 4x1-152/40, 8x1-120/40, 2x1-76/40, 2x1-37/20, 2x5-37/17, 4-450TT

						
	República	1 5	República	1894		1300t, 64.0ppx10.7x3.9m, 2hte, 3800hp, 17.4kts, 160p; steel- 51slopes, 25deck; 6x1-120/40, 4x1-57/40, (1+2x1)-356TT
	Almirante Barroso	1 6	Almirante Barroso	1897		3437t, 108.0x13.3x5.2m, 4b,2vte, 7500hp, 20.2kts, 366p; 88slopes, 31deck, 102CT; 6x1-152/50, 4x1-120/50, 10x1-57/40, 4x1-37/20, 3-450TT
CLL	Trajano	1 1	Tonelero	1873	No picture	1392t, 61.0ppx10.5x4.7m, 1hc, 2400hp, 11kts, 206p; 6x1-127/24
	Parnaíba	1 2	Parnaíba	1878	No picture	742t, 52.5ppx8.9x3.5m, 1hse, 900hp, 11.5kts, 149p; 6x1-127/24
	Primeiro de Março	1 3	Primeiro de Março	1881	No picture	750t, 50.8ppx8.4x3.5m, 1hc, 750hp, 8.5kts, 142p; 7x1-127/24

TORPEDO SHIPS

PGT	Tiradentes	1 1	Tiradentes	1893		795t, 50.3ppx9.1x3.3m, 2vte, 1646hp, 14.5kts, 110p; steel- 25CT; 4x1-120/40, 3x1-57/40, 2x1-356TT
	Gustavo Sampaio	1 2	Gustavo Sampaio	1893		480t, 60.0ppx6.1x2.6m, 2vte, 2000hp, 18kts, 60p; steel- 19CT; 2x1-89/40, 4x1-47/40, (1+2x1)-356TT
	Tupi	2	3	Tupi	1897	
4			Timbira	1897		
	Núm. 1	5 1-5	Núm. 1-5	1882	No picture	40(1)-52(2-5)t, 30.5(1)-33.5(2-5)x3.8x1.7m, 1b,1vc, 500hp, 20(1)-20.4(2-5)kts; 1x1-37/20, 2-356TT
	Tamborim	1 6	Tamborim	1884	No picture	16t, 19.2x2.4x0.9m, 1b,1vc, 60hp, 18kts; 1spar torpedo
	Sabino Voera	1 7	Sabino Voera	1884	No picture	13t, 19.2ppx2.3x1.0m, 1b,1vc, 17kts; 2-356TT
	Alpha	3 8-10	Alpha, Beta, Gamma	1885-1886	No picture	4t, 13.7x1.8x0.4m, 1b,1vse, 12.3kts; 1spar torpedo

TB	Piratini	1	11	Piratini	1879		165/259t, 39.6x5.2x2.7/3.4m, 1b,1vse, 1000hp, 15/10kts; iron- 406breastwork; 2x1-37/20, 1-340 TT
	Araguari	4	12	Araguari	1893	No picture	110t, 45.7x4.4x1.1m, 2b,1vte, 1800hp, 25kts, 27p; 2x1-47/42, (1+2x1)-381TT
			13	Bento Gonçalves	1893		
			14	Marcílio Dias	1893		
			15	Iguatemi	1893		
	Panne	5	16	Panne	1892		130t, 46.3x5.3x2.4m, 2b,2vte, 2200hp, 26kts, 24p; 2x1-37/37, (1+2x1)-356TT
			17	Pedro Affonso	1892		
			18	Pedro Ivo	1892		
			19	Pernambuco	1892		
			20	Silvado	1892		
Moxotó	1	21	Moxotó	1893	No picture	17t, 18.3x2.8x1.2m, 1b,1vc, 230hp, 16kts; 2x1-37/20, 1-340TT	
Potí	1	22	Potí	1893	No picture	30t, 38.4x3.7x0.9m, 18kts; 1x1-37/20, 1-340TT	
Inhandua	1	23	Inhandua	1893	No picture	17t, 19.3x3.0x0.9m, 23kts; 1x1-37/20, 1-340TT	

OTHER FIGHTING SHIPS



RMON	Pará	2	1	Rio Grande	1867		490t, 39.0x8.5x1.5m, 2b,2hda, 180hp, 8kts, 43p; iron- 102belt, 13deck, 152turret; 1x1-163/23 or 1x1-127/24
			2	Alagoas	1867		
PG	Afonso Celso	1	1	Trindade	1883	No picture	327t, 30.8x6.7x2.8m, 1vc, 120hp, 13kts; 2x1-76/23, 1x1-25/42
PGR	Yutohy	2	1, 2	Yutohy, Teffé	1892	No picture	33t, 27.4ppx4.6x1.5m, 11kts; 1x1-47/40

© Ivan Gogin, 2015

[home](#)[World navies yesterday](#)[1900](#)

Bulgaria 01 January 1900

TORPEDO SHIPS

PGT	Nadezhda	1	1	Nadezhda	1898		715t, 67.0x8.3x3.1m, 4b,2vte, 2600hp, 18kts, 97p; 2x1-100/45, 2x1-65/50, 2x1-47/40, 2x1-381TT
TB	Vasil Levski	2	1, 2	Vasil Levski, Khristo Botev	1877-1878		20t, 18.3x2.3x1.1m, 1b,1vc, 220hp, 13kts, 9p; 2spar torpedoes

© Ivan Gogin, 2015

[home](#)

[World navies yesterday](#)

[1900](#)

Cambodia 01 January 1900

OTHER FIGHTING SHIPS



PG	Lutin	1	1	Lutin	1877		492t, 44.1x7.3x3.3m, 2b,1hc, 440hp, 11kts, 76p; 2x1-139/21, 2x1-90/36, 4x5-37/17
----	-------	---	---	-------	------	---	--

© Ivan Gogin, 2015

[home](#)[World navies yesterday](#)[1900](#)

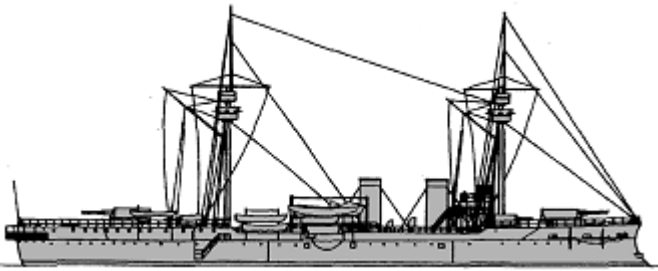

Chile 01 January 1900

BATTLESHIPS

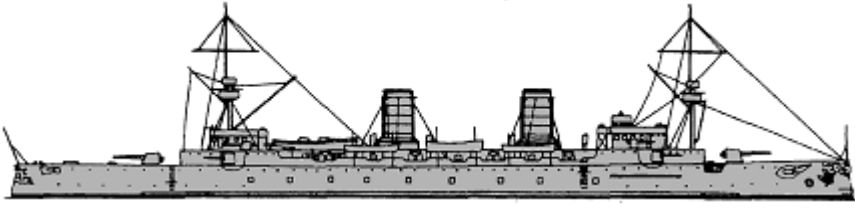

BB	Capitán Prat	1	1	Capitán Prat	1893		6901t, 100.0ppx18.5x7.0m, 5b,2hte, 12000hp, 18.3kts, 480p; steel- 300belt, 50deck, 275barbettes, 265CT; 4x1-240/36, 4x2-120/45, 6x1-57/40, 4x1-47/40, 10x1-37/20, 4-450TT
BC	Cochrane	1	1	Cochrane	1874		3560t, 64.0ppx13.9x6.7m, 6b,2hte, 4300hp, 13.6kts, 300p; iron- 229belt, 203battery, 76CT; 6x1-203/30, 3x1-57/40, 6x1-37/20, 3-356TT
MON	Huascár	1	1	Huascár	1866		2030t, 57.9ppx10.7x5.6m, 4b,1hse, 1650hp, 12.3kts, 170p; iron- 114belt, 203turret, 76CT; 1x2-203/26, 2x1-57/40, 2x5-37/17

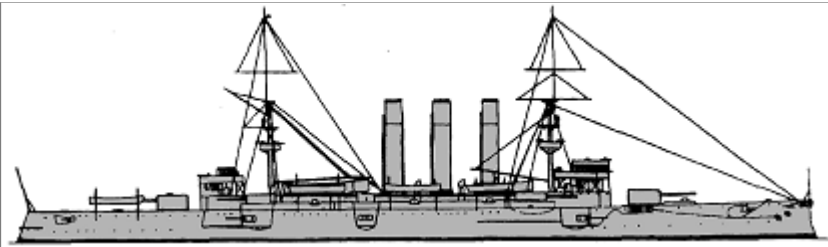
CRUISERS

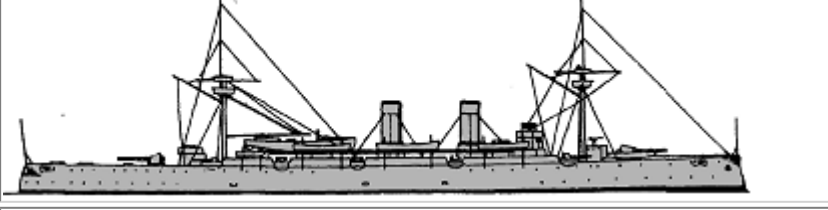
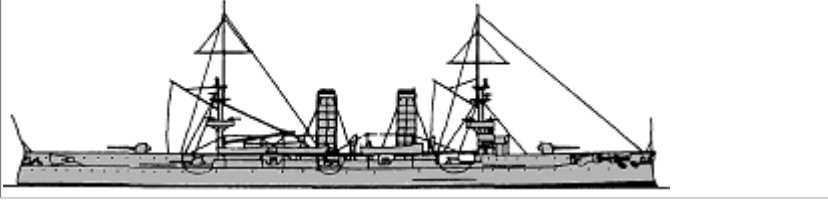
CA	Esmeralda	1	1	Esmeralda	1896		7000t, 132.9ppx16.2x6.2m, 12b,2vte, 16000hp, 22.2kts, 500p; Harvey- 152belt, 51deck, 114shields, 203CT; 2x1-203/40, 16x1-152/40, 8x1-76/40, 3-450TT
	O'Higgins	1	2	O'Higgins	1898		8500t, 135.2x19.1x6.7m, 30b,2vte, 16000hp, 21kts, 500p; Harvey- 178belt, 51deck, 178turrets, 229CT; 4x1-203/40, 10x1-152/40, 4x1-120/44, 10x1-76/40, 10x1-57/40, 3-450TT

							
CL	Presidente Errázuriz	1	Presidente Errázuriz	1892		2047t, 81.8ppx10.9x4.4m, 4b,2hte, 5400hp, 18.3kts, 170p; steel- 60slopes, 35deck, 90shields, 50CT; 4x1-150/36, 2x1-120/36, 4x1-57/40, 3-356TT	
		2	Presidente Pinto	1892			
	Blanco Encalada	1	3	Blanco Encalada	1894		4568t, 112.8ppx14.2x5.6m, 8b,2vte, 14600hp, 22.8kts, 427p; steel- 102slopes, 44deck, 152shields, 152CT; 2x1-203/40, 10x1-152/40, 12x1-76/40, 12x1-37/20, 5-450TT
	Ministro Zenteno	1	4	Ministro Zenteno	1898		3437t, 100.6ppx13.3x5.1m, 8b,2vte, 7500hp, 20.2kts, 317p; steel- 89slopes, 32deck, 102CT; 8x1-152/45, 10x1-57/40, 4x1-37/20, 3-450TT

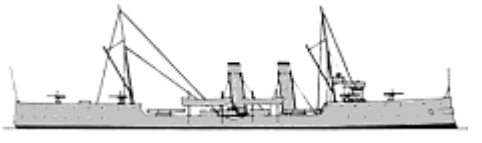
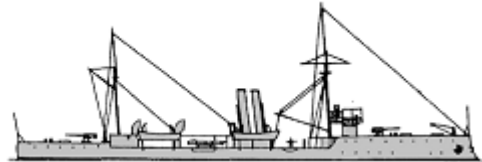
TORPEDO SHIPS

PGT	Almirante Lynch	1	Almirante Lynch	1890		713t, 70.1ppx8.4x2.5m, 4b,2vte, 4275-4532hp, 20.3-20.6kts, 87p; steel- 25deck; 3x1-76/40, 4x1-47/40, (1+4x1)-356TT	
		2	Almirante Condell	1890			
	Almirante Simpson	1	3	Almirante Simpson	1896		800t, 73.2ppx8.4x4.3m, 4b,2vte, 4500hp, 21.5kts; steel- 25deck, 51CT; 2x1-120/40, 4x1-47/40, (1+2x1)-450TT
DD	Capitán Orella	1	Capitán Orella	1896		300t, 64.9ppx6.6x1.8m, 4b,2vte, 6250hp, 30kts, 65p; 1x1-76/40, 5x1-57/40, 2x1-450TT	
		2	Capitán Muñoz Gamero	1896			
		3	Teniente Serrano	1896			
		4	Guardiamarina Riquelme	1896			
	Glaura	1	1	Rucumilla	1882	No picture	35t, 30.5x3.8x2.1m, 1b,1hse, 400hp, 19kts, 15p; 1x2-25/42, 2spar torpedoes
	Fresia	1	2	Quidora	1881	No picture	25t, 26.2x3.8x1.5m, 1b,1hse, 400hp, 20kts, 15p; 1x2-25/42, 2spar torpedoes

TB	Sargente Aldea	1	3	Sargente Aldea	1886	No picture	80t, 38.1x4.0x2.1m, 1b,1vc, 700hp, 20kts, 16p; 2x2-25/42, 2-356TT
	Ingeniero Hyatt	6	4	Cirujano Videla	1896		140t, 46.5x4.7x2.4m, 2b,1vte, 2200hp, 27kts, 16p; 3x1-47/40, (1+1x2)-356TT
			5	Ingeniero Mery	1896		
			6	Ingeniero Hyatt	1896		
			7	Teniente Rodriguez	1896		
			8	Ingeniero Mutilla	1898		
9	Guardiamarina Contreras	1898					

OTHER FIGHTING SHIPS



PG	Magallanes	1	1	Magallanes	1874	No picture	950t, 61.0x9.1x3.5m, 2hc, 1040hp, 11kts, 200p; 1x1-178/14, 1x1-161/14, 2x1-95/16
	Pilcomayo	1	2	Pilcomayo	1875	No picture	800t, 55.4ppx7.5x3.5m, 1hc, 1080hp, 11kts, 130p; 2x1-147/21, 2x1-121/22

© Ivan Gogin, 2015

[home](#)[World navies yesterday](#)[1900](#)

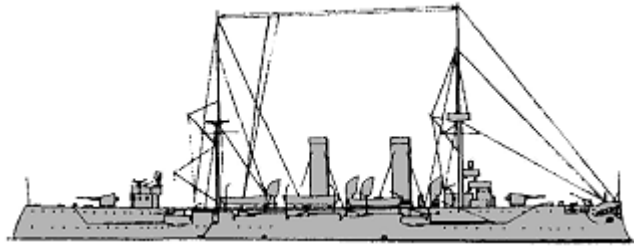
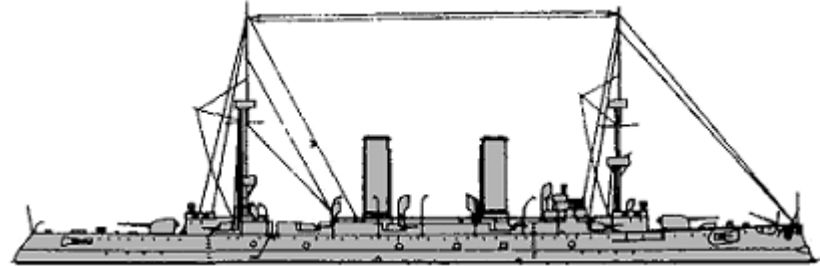

China 01 January 1900

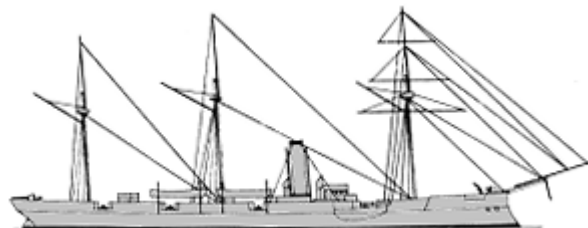
CRUISERS

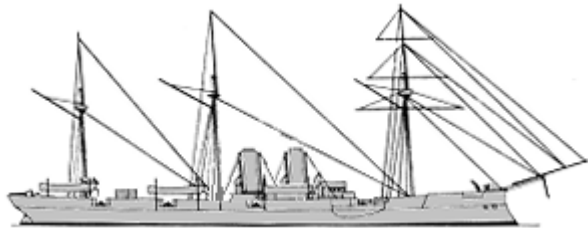
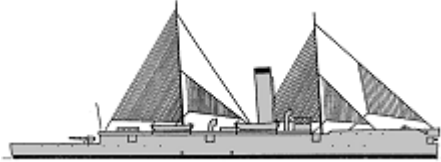
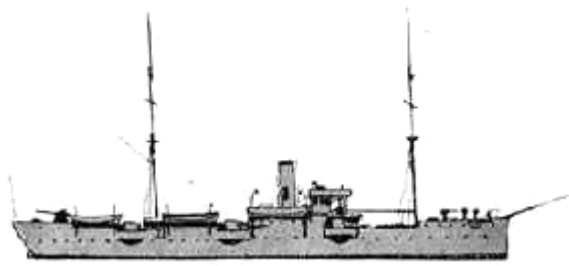
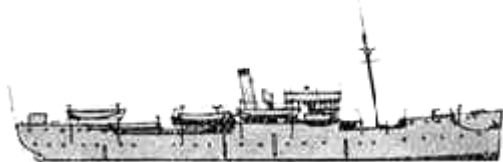
CL	Hai Yung	1	Hai Yung	1898		2950t, 100.0x12.4x5.8m, 8b,2vte, 7500hp, 19.5kts, 244p; 70slopes, 32deck, 51shields, 37CT; 3x1-149/37, 8x1-105/37, 6x1-47/37, 3-356TT
		2	Hai Chou	1898		
3		Hai Chen	1898			
CL	Hai Chi	4	Hai Chi	1899		4515t, 129.2x14.2x5.5m, 12b,4vte, 17000hp, 24kts, 350p; Harvey- 127slopes, 37deck, 114turrets, 152CT; 2x1-203/45, 10x1-120/45, 16x1-47/40, 5-450TT
		5	Hai Tien	1899		
CL	Wei Yuen	1	Wei Yuen	1877		1258(1-3)-1477(4,5)t, 66.2(1-3)-68.3(4,5)x9.0x3.8m, 750(1-3)-1200(4,5)hp, 11(1-3)-15(4,5)kts, 180p; iron-32shields; 1x1-160/14(1,3), 2x1-152/26(2), 2x1-149/32(4,5), 6x1-121/22(1,3-5), 7x1-121/22(2), 1x1-120/32(4,5)
		2	Chao Wu	1879		
		3	Kang Chi	1880		
		4	Ching Ch'ing	1885		
		5	Heng Hai	1885		
CL	Kai Che	6	Kai Che	1884		2150(6)-2100(7,8)t, 76.9(6)-76.2(7,8)x11.0x5.6(6)-5.5(7,8)m, 8b,1hc(6)-8b,1hte(7,8), 2400hp, 14.5(6)-16(7,8)kts, 300p; steel- casemates; 2x1-209/20(6), 3x1-178/26(7,8), 7x1-121/22(7,8), 7x1-120/32(6), 6x4-25/42(6), 2-356TT(7,8)
		7	King Ch'ing	1886		
		8	Huan T'ai	1888		
		9	Nan Thin	1884		

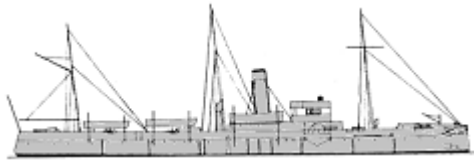
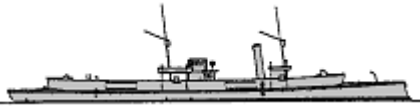
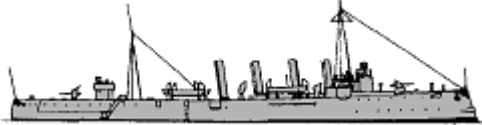

CLL	Nan Thin	2	10	Nan Shui	1884		2200t, 84.0x11.0x5.5m, 8b,1hc, 2400hp, 15kts, 250p; 2x1-209/20, 8x1-120/32, 10x4-25/42, 1-356TT
	Pao Min	1	11	Pao Min	1885		1480t, 69.4x11.0x4.3m, 6b,2hc, 1900hp, 9kts, 200p; 2x1-149/32, 6x1-120/32, 2x1-47/40
	Tung Chi	1	12	Tung Chi	1896		1900t, 77.0ppx10.4x4.9m, 4b,1vc, 1600hp, 11.6kts, 335p; 2x1-152/40, 5x1-120/45, 3x1-57/40, 8x1-37/20
	Fu An	1	13	Fu An	1897		1700t, 76.8ppx11.6x5.5m, 4b,1vc, 1600hp, 10kts, 105p; 2x1-57/40

TORPEDO SHIPS

PGT	Kuang Ping	1	1	Fu Ch'ing	1894		1000t, 71.6x8.2x4.0m, 3b,2hte, 2400hp, 16kts, 120p; steel- 25deck, 51CT; 3x1-120/32, 4x1-47/40, (2+2x1)-356TT
	Fei Ting	1	2	Fei Ting	1894		401t, 63.7x7.2x3.1m, 2vte, 3000hp, 21.2kts, 50p; steel- 45CT; 2x1-95/40, 4x1-47/40, (1+2x2)-356TT
	Fei Ying	1	3	Fei Ying	1896		850t, 75.0x8.6x4.0m, 8b,2vte, 5430hp, 22kts, 90p; 25deck, 50shields; 2x1-105/37, 6x1-57/40, 4x1-37/20, (1+2x1)-356TT
DD	Hai Lung	4	1	Hai Hoha	1898		284t, 59.0x6.4x2.6m, 4b,2vte, 6000hp, 33.6kts, 57p; 6x1-47/30, 2x1-356TT
			2	Hai Lung	1898		
			3	Hai Hse	1898		
			4	Hai Ying	1898		
	Lei Fu	2	1, 2	Lei Fu, Lei Lung	1884	No picture	64t, 35.0x4.0x1.7m, 2b,1vte, 700hp, 19.8kts, 20p; 2x5-37/17, 2-356TT
	Lei Chen	9	3- 11	Lei Chen, Lei Chung, Lei Kong, Lei Kwong, Lei Kung, Lei Li, Lei Sun, Lei Tsen, Lei Tui	1885	No picture	27t, 26.0x3.6m, 1b,1vc, 420hp, 19.5kts; 1-356TT

TB	Chang Tze	2	12, 13	No1 Chang Tze, No3 Lieh Tze	1895	No picture	89t, 39.0x4.8x1.5m, 1b,1vc, 600hp, 18kts, 31p; 2x5-37/17, (2+1x1)-356TT
	Chen Tse	2	14	No2 Chen Tse	1896		126t, 43.9x5.2x2.4m, 2b,1vte, 1000hp, 18kts, 31p; 2x5-37/17, (2+1x1)-450TT
			15	No4 Su Tse	1896		

OTHER FIGHTING SHIPS

PG	Kwangtung	2	1	An Lan	1868	No picture	440t, 42.7x7.2x2.7m, 3b,1hr, 255hp, 9.3kts, 60p; 1x1-178/16, 2x1-121/22
			2	Chen T'ao	1868		
	Tien Chi	1	3	Tien Chi	1868	No picture	600t, 56.4x8.3m, 1b,1hse(sw), 150hp; 15x1-155/8
	Tse Hai	1	4	Tse Hai	1869		600t, 53.4x8.5m, 1b,1hse, 430hp, 12.5kts; 15x1-155/8
	Wei Ching	1	5	Wei Ching	1870	No picture	1000t, 62.5x9.9m, 1b,1hse, 600hp, 12.5kts; 1x1-178/16, 4x1-127/14
	Chen Hai	2	6	Chen Hai	1872	No picture	578t, 49.0x8.0x3.2m, 2b,1hse, 480hp, 10kts, 70p; 2x1-160/16(6), 1x1-160/16(7), 4x1-121/22
			7	Ching Yuan	1873		
	Fei Ting	2	8	Fei Ting	1876		420t, 36.6x9.1x2.4m, 1b,2hcr, 270hp, 9.5kts, 30p; iron- 13shield, 13CT; 1x1-318/16, 2x1-70/22, 1x4-25/42
			9	Tse Tien	1876		
	Hai Ch'ang Ch'ing	1	10	Hai Ch'ang Ch'ing	1877		430t, 38.1x9.1x2.4m, 1b,2hcr, 70hp, 7.5kts; 1x1-279/12, 2x1-76/28
	Kuang Yuan	4	11	Kuang Yuan	1886	No picture	300t, 33.8x5.5x2.3m, 2hrcr, 65-78hp, 9-10kts; 1x1-149/32, 1x1-88/32, 3x1-37/42
			12	Kuang Heng	1886		
			13	Kuang Li	1886		
			14	Kuang Chien	1886		
	Kuang Keng	4	15	Kuang Keng	1887	No picture	560t, 43.0x7.3x3.7m, 1vr, 400hp, 11kts; 2x1-121/22, 1x1-100/22, 2x1-47/40
			16	Kuang Hsing	1887		
			17	Kuang Jen	1887		
			18	Kuang Kuei	1887		
	Chen Sheng	1	19	Chen Sheng	1899	No picture	275t, 36.6x6.1x2.1m, 1vc, 400hp, 10kts, 42p; 1x1-76/40, 1x1-57/40

CUSTOMS FLOTILLAS

	Kua Hsing	1	1	Kua Hsing	1869	No picture	(sw)
	Fei Hoo	2	2	Fei Hoo	1869	No picture	319brt, 39.7x7.4m, 2x1-95/22
			3	Ling Feng	1869		
	Peng Chao Hai	1	4	Peng Chao Hai	1869	No picture	600brt, 54.9x7.3m; 2x1-121/22, 2x1-95/22

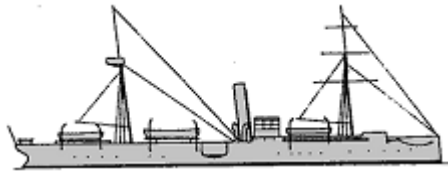
CGC	Ping Ching	1	5	Ping Ching	1880	No picture	1000t, 64.7x9.2m, 1x1-160/16, 4x1-109/17, 1x1-88/22
	Poo Too	1	6	Poo Too	1880s	No picture	160t
	Fee Cheu	1	7	Fee Cheu	1887		1300t, 67.1x9.8x4.0m, 13kts; 2x1-152/26
	Chuen Tiao	1	8	Chuen Tiao	1888	No picture	716t, 47.3x7.6x3.5m, 10kts; 2x1-95/21, 2x1-47/40
	Likin	2	9	Likin	1888	No picture	512t, 41.2x7.0x3.5m, 10kts; 2x1-95/21, 2x1-47/40
10			Kaipan	1888			

© Ivan Gogin, 2015

[home](#)[World navies yesterday](#)[1900](#)

Colombia 01 January 1900

OTHER FIGHTING SHIPS

PG	Boyacá	1	1	Boyacá	1883	No picture	
	La Popa	1	2	La Popa	1887	No picture	
PGR	General Pinzón	1	1	General Pinzón	1881	No picture	740t, (stw), 13kts; 3x1-37/20
	Esperanza	2	2	Esperanza	1897	No picture	400t, 42.4ppx5.8x0.9m, (stw), 430hp, 15kts; 3x1-37/20
			3	General Nerín	1895		
Chercinto	1	4	Chercinto	1896	No picture	643t, 56.4x9.4x3.7m, 400hp, 12kts; 3x1-37/20	
APGR	-	1	1	Bolívar	1870		981t

© Ivan Gogin, 2015

[home](#)

[World navies yesterday](#)

[1900](#)

Costa Rica 01 January 1900

TORPEDO SHIPS

TB	no name	1	1	no name	1890	No picture	15t, 18.3x2.8x1.1m, 1b,1vte, 230hp, 17kts; 1x1-47/40, 1-356TT
----	---------	---	---	---------	------	------------	---

© Ivan Gogin, 2015

[home](#)[World navies yesterday](#)[1900](#)

Cuba 01 January 1900

COAST GUARD SHIPS

CGC	Veinte de Mayo	1	1	Veinte de Mayo	1895	No picture	203t, 45.7x5.6x3.2m, 500hp, 12kts, 43p; 2x1-47/40, 2x1-37/40
	Yara	1	2	Yara	1895	No picture	449t, 47.2x7.9x4.0m, 600hp, 12kts, 53p; 2x1-57/40, 2x1-47/40
	Alfredo	1	3	Alfredo	1896	No picture	40t, 18.3x3.7x1.8m, 11kts; 1x1-37/40
	Maceo	3	4-6	Maceo, Céspedes, Argamonte	1896	No picture	35t, 22.9x3.1x1.7m, 10kts; 1x1-37/40
	Enrique Villuendas	1	7	Enrique Villuendas	1899	No picture	178t, 40.2x6.1x2.7m, 600hp, 16kts; 2x1-47/40

© Ivan Gogin, 2015

[home](#)[World navies yesterday](#)[1900](#)

Denmark 01 January 1900

BATTLESHIPS

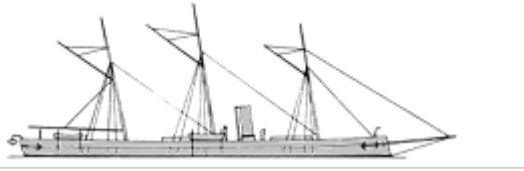
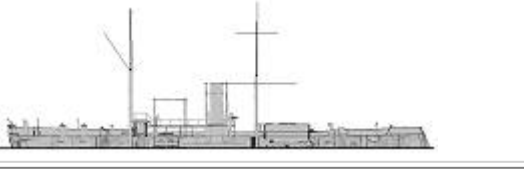
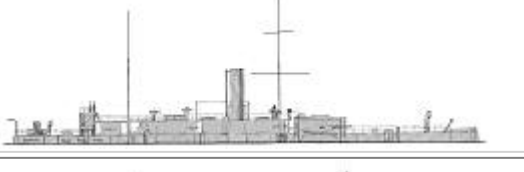
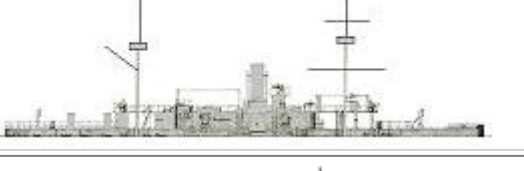
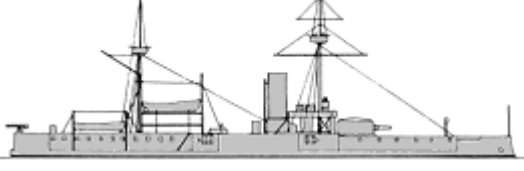
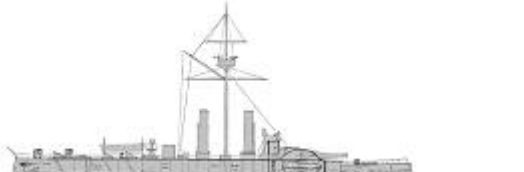
	Rolf Krake	1	1	Rolf Krake	1863		1320t, 57.0x11.6x3.2m, 4b,2hr-cr, 750hp, 9.5kts, 150p; iron- 114side, 114turrets; 2x1-203/13, 2x1-87/21, 4x5-37/17
	Lindormen	1	2	Lindormen	1869		2105t, 66.4x12.0x4.4m, 4b,2hr-cr, 1500hp, 12kts, 150p; iron- 127side, 140turret; 1x2-229/14, 4x1-87/21, 4x1-37/20
	Gorm	1	3	Gorm	1871		2350t, 71.7x12.2x4.4m, 4b,2hr-cr, 1600hp, 12.5kts, 160p; iron- 178side, 203turret; 1x2-254/14, 4x1-57/40, 6x5-37/17
	Odin	1	4	Odin	1874		3230t, 73.4ppx14.8x5.0m, 4b,2hr-cr, 2300hp, 12kts, 206p; compound- 203side, 203battery; 4x1-254/15, 4x1-87/21, 6x5-37/17
BC	Helgoland	1	5	Helgoland	1879		5332t, 79.1x18.0x5.9m, 8b,2hr-cr, 4000hp, 13.7kts, 331p; iron- 305belt, 254barbette; 1x1-305/19, 4x1-263/19, 4x1-120/22, 2x1-57/40, 3x1-37/20, 4x5-37/17, 2-381TT, 3-356TT
	Tordenskjold	1	6	Tordenskjold	1882		2462t, 67.8x13.2x4.8m, 8b,2vc, 2600hp, 12.7kts, 206p; compound- 97slopes, 38deck, 203barbette; 1x1-355/22, 4x1-120/22, 8x5-37/17, 1-381TT, 3-356TT
	Iver Hvitfeldt	1	7	Iver Hvitfeldt	1887		3478t, 74.5ppx15.1x5.6m, 8b,2vc, 5100hp, 15.2kts, 277p; compound- 295belt, 53deck, 215barbette, 115CT; 2x1-263/32, 4x1-120/27, 2x1-57/40, 8x5-37/17, 2-381TT, 2-356TT

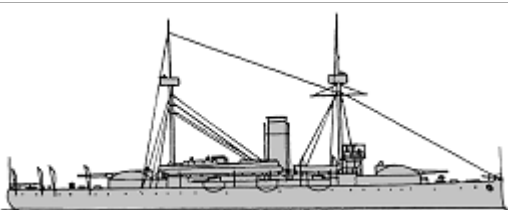
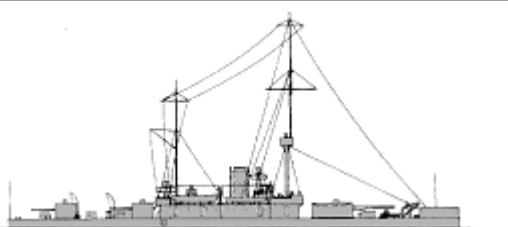



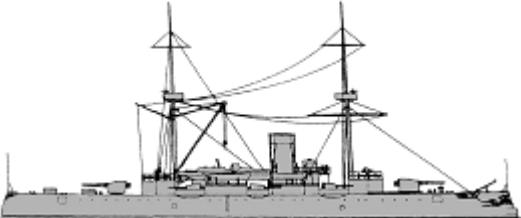
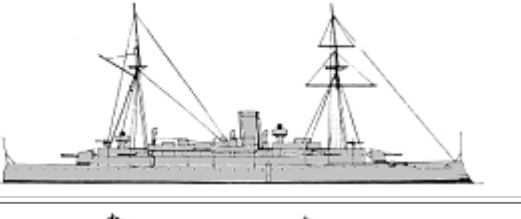
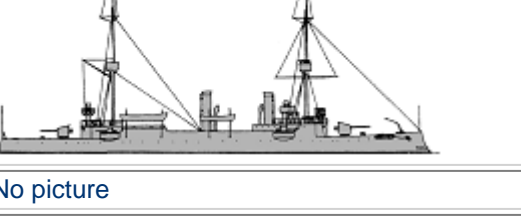

							
	Skjold	1	8	Skjold	1897		2195t, 69.4x11.6x4.2m, 4b,2vte, 2400hp, 14kts, 138p; Harvey- 229belt, 50deck, 250turret; 1x1-240/37, 3x1-120/38, 4x1-47/40

CRUISERS



CL	St. Thomas	1	1	St. Thomas	1872	No picture	1550t, 70.1x10.0x5.2m, 1800hp, 13kts, 182p; 1x1-203/13, 4x1-154/16, 1x1-84/13
	Valkyrien	1	2	Valkyrien	1890		3020t, 85.8x13.2x5.5m, 6b,2vte, 5200hp, 17kts, 282p; steel- 65deck; 2x1-209/32, 6x1-149/32, 4x1-57/40, 8x5-37/17, 5-381TT
	Hekla	1	3	Hekla	1891		1300t, 72.3x10.4x3.5m, 8b,2vte, 3000hp, 17kts, 156p; steel- 43deck; 2x1-149/32, 4x1-57/40, 6x5-37/17, 4-381TT
	Gejser	2	4	Gejser	1893		1282(4)-1342(5)t, 72.3x10.4x3.5m, 8b,2vte, 3000hp, 17kts, 156p; steel- 50(4)-45(5)deck; 2x1-120/38, 4x1-87/37, 2x1-37/20, 4x5-37/17, 1-450TT, 3-381TT
			5	Hejmdal	1895		
CLL	Dagmar	1	1	Dagmar	1862	No picture	1222t, 54.4x10.3x5.0m, 1hda, 500hp, 9kts, 190p; 8x1-120/27, 2x5-37/17
	Ingolf	1	2	Ingolf	1878	No picture	1012t, 63.9x8.5x4.2m, 630hp, 10.2kts, 156p; 4x1-120/38, 4x5-37/17
	Fyen	1	3	Fyen	1884	No picture	2663t, 69.0ppx13.8x6.1m, 2600hp, 12.5kts, 300p; 2x1-149/32, 14x1-149/22, 8x5-37/17, 2-356TT

TORPEDO SHIPS

	Nr.6	1	1	Sværdfisken	1881		58t, 33.5x3.7x1.8m, 1b,1vc, 600hp, 17kts, 15p; 1x5-37/17, 2-381TT
	Delfinen	1	2	Delfinen	1883		66t, 33.6x3.6x0.7m, 1b,1vc, 670hp, 17kts, 15p; 1x5-37/17, 2-381TT
	Hvalrossen	1	3	Hvalrossen	1884		74t, 34.5x3.7x2.0m, 1b,1vc, 660hp, 17kts, 15p; 1x5-37/17, 2-381TT

TB1cl	Støren	2	4	Støren	1887		107t, 39.7x4.2x2.2m, 2b,1vc, 1200hp, 18.5kts, 20p; 2x5-37/17, (2+1x2)-381TT
			5	Søløven	1887		
	Nahrvalen	2	6	Nahrvalen	1888		111t, 41.1x4.2x2.2m, 2b,1vc, 1200hp, 18.5kts, 20p; 2x5-37/17, (2+1x2)-381TT
			7	Havhesten	1888		
	Springeren	1	8	Springeren	1891		89t, 36.3x4.0x2.1m, 2b,1vc, 800hp, 17.5kts, 17p; 2x5-37/17, 2-450TT
	Nordkaperen	2	9	Nordkaperen	1893		127t, 42.5x4.3x2.2m, 2b,1vc, 1300hp, 19kts, 20p; 2x5-37/17, 2-450TT, 1x2-381TT
10			Makrelen	1894			
Hajen	1	11	Hajen	1896		141t, 42.9x4.6x2.5m, 2b,2vte, 2000hp, 22kts, 25p; 1x1-47/40, 1x5-37/17, 2-450TT, 1x2-381TT	
Havørnen	2	12	Havørnen	1897		142t, 44.4x4.7x2.4m, 2b,2vte,2 100hp, 22kts, 25p; 1x1-47/40, 1x5-37/17, (2+1x2)-450TT	
		13	Søbjørnen	1898			
TB2cl	Nr.4	1	1	Nr.2	1879		32t, 27.8x3.0x1.6m, 1b,1vc, 350hp, 15.5kts, 12p; 1x1-37/20, 1-356TT
	Nr.5	1	2	Nr.3	1880	No picture	37t, 29.0xxm, 1b,1vc, 450hp, 15kts; 1x1-37/20, 2-356TT
	P8	2	3, 4	P8, 9	1894-1895	No picture	48t, 25.6x3.8x1.8m, 1vte, 330hp, 13kts, 13p; 1x1-47/40, 1x5-37/17, 1x1-356TT
	Nr.10	2	5, 6	P2, 3	1878	No picture	14t, 14.6x2.8x1.2m, 1b,1hda, 10.5kts, 8p; 1x5-37/17
	Nr.4	1	7	Nr.4	1882	No picture	15t, 18.8x2.2x1.1m, 1b,1vc, 150hp, 13kts, 6p; 1x1-37/20, 2-356TT
	Nr.6	2	8, 9	Nr.6, 7	1884	No picture	15t, 20.1x2.4x1.3m, 1b,1vc, 150hp, 13kts, 6p; 1x1-37/20, 2-356TT
	Nr.8	2	10, 11	Nr.8, 9	1886	No picture	15t, 20.6x2.4x1.2m, 1b,1vc, 170hp, 13kts, 6p; 1x1-37/20, 2-356TT
	Nr.10	2	12, 13	Nr.10, 11	1888	No picture	17t, 21.0x2.4x1.2m, 1b,1vc, 180hp, 13.5kts, 6p; 1x1-37/20, 2-356TT
	Nr.12	2	14, 15	Nr.12, 13	1889	No picture	25t, 23.8x2.7x1.3m, 1b,1vc, 350hp, 15kts, 6p; 1x1-37/20, 2-356TT
P4	4	16-19	P4-7	1889-1890	No picture	20t	

OTHER FIGHTING SHIPS

PG	Absalon	2	1	Absalon	1862	No picture	533t, 47.8x7.9x3.3m, 500hp, 11kts, 50p; iron- 64belt; 2x1-120/27(1), 2x1-87/21(1), 2x5-37/17(2), 1-381TT(2), 1x1-356TT(2)
			2	Esbern Snare	1862		
	Fylla	1	3	Diana	1864	No picture	560t, 47.8x7.9x3.1m, 500hp, 9.7kts, 58p; 2x1-37/20
	Falster	1	4	Falster	1874		390t, 34.3x8.8x2.6m, 510hp, 10.5kts, 50p; 1x1-254/18, 2x1-84/13
PG	Øresund	3	5	Øresund	1875	No picture	240t, 26.1x8.0x2.1m, 200hp, 7.5kts, 36p; 1x1-254/18, 2x1-84/13
			6	Store Bælt	1875		
			7	Lille Bælt	1876		
	Møen	1	8	Møen	1875		409t, 34.3x8.8x2.6m, 523hp, 9kts, 35p; 1x1-254/18, 6x5-37/17
PG	Grønsund	2	9	Grønsund	1883	No picture	247(9)-268(10)t, 36.3x6.1x2.5m, 300(9)-400(10)hp, 10(9)-10.5(10)kts, 46-49p; 2x1-57/40(9), 2x1-47/40(10), 2x5-37/17(9)
			10	Guldborgsund	1885		
BR	Ørnen	1	1	Ørnen	1880	No picture	300t

MINE WARFARE SHIPS

ML	Hjælperen	1	1	Hjælperen	1891	No picture	288t, 38.3x6.8x2.3m, 330hp, 25p; 3x5-37/17, mines
----	-----------	---	---	-----------	------	------------	---



© Ivan Gogin, 2014

[home](#)[World navies yesterday](#)[1900](#)

Dominican Republic 01 January 1900

OTHER FIGHTING SHIPS

PG	El Presidente	1	1	El Presidente	1873	No picture	389t, 63.7x6.6m, 105hp, 13.8kts, 50p; 4x1-121/22
	Independencia	1	2	Independencia	1894	No picture	322t, 51.8x7.6m, 2vte, 15kts; 7x1-small guns
	Restauración	1	3	Restauración	1896	No picture	1000t, 65.2x9.1m, 2vte, 14kts; 4x1-120/40, 5x1-small guns

© Ivan Gogin, 2015

[home](#)[World navies yesterday](#)[1900](#)

Ecuador 01 January 1900

TORPEDO SHIPS

TB	Tungurahua	1	1	Tungurahua	1890s		65t
----	------------	---	---	------------	-------	---	-----

ESCORTS

AY	-	1	1	Cotopaxi	1884		300t; 4x1-76/40
----	---	---	---	----------	------	--	-----------------

OTHER FIGHTING SHIPS



APG	-	2	1	Nueve de Julio			
			2	Patria			300brt

© Ivan Gogin, 2015

[home](#)[World navies yesterday](#)[1900](#)

Egypt 01 January 1900

ESCORTS

PC	Noor El Bahr	1	1	Noor El Bahr	1884		450t
	Nesim	1	2	Nesim	1885	No picture	81t
	Marda	1	3	Marda	1886	No picture	154t
	Zarif	1	4	Zarif	1886	No picture	144t
	Saria	1	5	Saria	1886	No picture	71t
	Abbas	1	6	Abbas	1891		298brt

OTHER FIGHTING SHIPS

PG	Khartum	1	1	Khartum	1862	No picture	455t
	Dongola	1	2	Dongola	1863	No picture	300t
	Jeafferieh	1	3	Jeafferieh	1865	No picture	690t
PGR	Tamai	4	1-4	Tamai, Hafir, Metemmeh, Abu Klea	1884-1885	No picture	74t, (stw); 1x1-76/40
	El Zafir	3	5	El Zafir	1896	No picture	128t, (stw); 1x1-76/40
			6	El Fateh	1897		
			7	El Nasir	1897		
	Sultan	3	8	Sheik	1896	No picture	140t; 1x1-76/40
			9	Sultan	1896		
			10	Melik	1897		

© Ivan Gogin, 2015

[home](#)

[World navies yesterday](#)

[1900](#)

El Salvador 01 January 1900

OTHER FIGHTING SHIPS

PG	Cuscatlan	1	1	Cuscatlan	1890	No picture	75t, 10kts; 1x1-small gun
----	-----------	---	---	-----------	------	------------	---------------------------

© Ivan Gogin, 2015

[home](#)[World navies yesterday](#)[1900](#)

France 01 January 1900

BATTLESHIPS

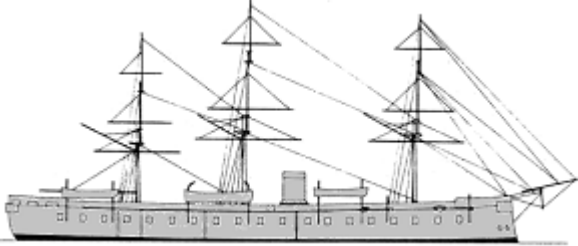
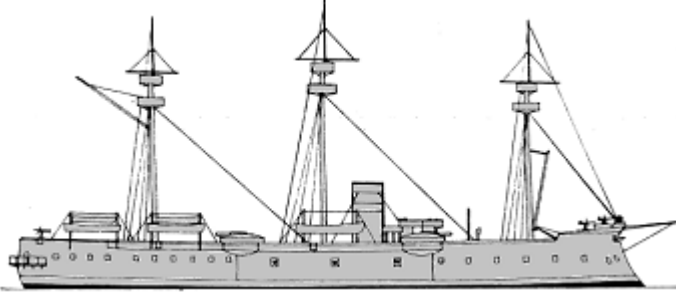
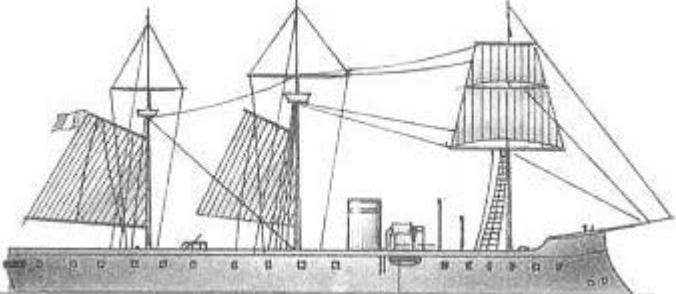
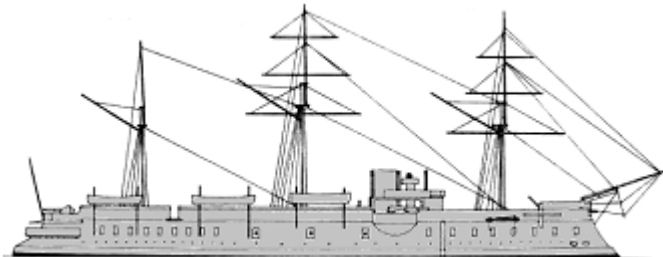
Couronne	1	1	Couronne	1862		5983t, 80.9x16.7x8.2m, 8b,1hr, 2900hp, 13kts, 570p; iron- 120belt; 8x1-240/18, 4x1-194/20, 2x1-120/25, 12x5-37/20
Richelieu	1	2	Richelieu	1875		8984t, 101.7x17.5x8.7m, 8b,2hr, 4200hp, 13kts, 750p; iron- 220belt, 13deck, 160barbettes, 100CT; 6x1-274/18, 5x1-240/18, 6x1-139/21, 18x5-37/20, 4-350TT
Friedland	1	3	Friedland	1877		8850t, 101.1x17.7x9.0m, 8b,1hr, 4400hp, 13.3kts, 700p; iron- 200belt, 160battery; 8x1-274/18, 8x1-139/21, 22x5-37/20, 4-350TT
Colbert	2	4	Colbert	1877		8750t, 101.1(4)-102.1(5)x17.5x8.5(4)-8.8(5)m, 8b,1hr, 4600hp, 14kts, 774p; iron- 220belt, 15deck, 160battery; 8x1-274/18, 2x1-240/18, 6x1-139/21, 14x5-37/20(4), 18x5-37/20(5), 4-350TT(4), 6-350TT(5)
		5	Trident	1878		

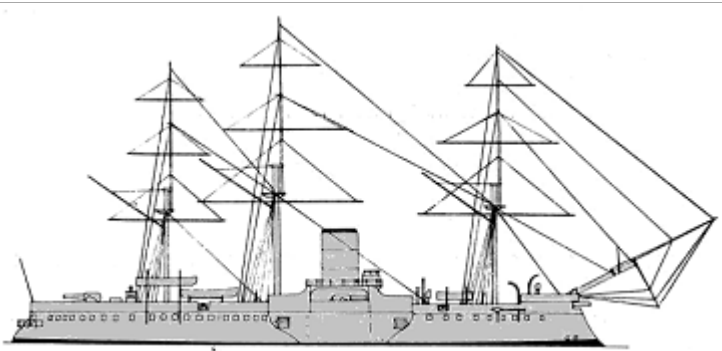
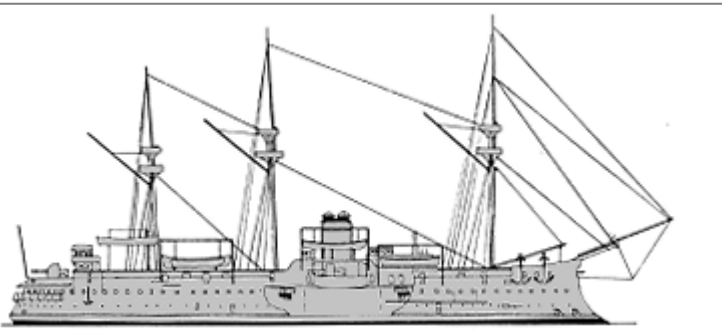
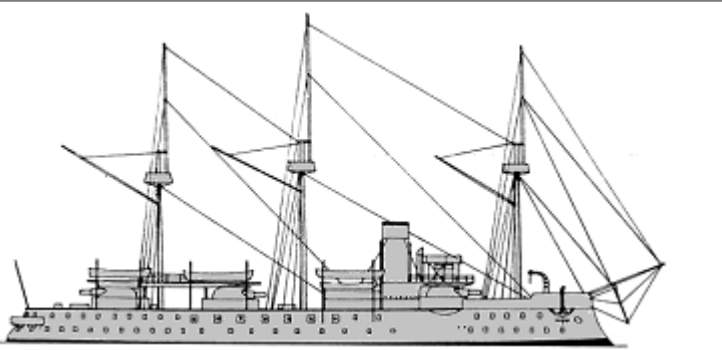
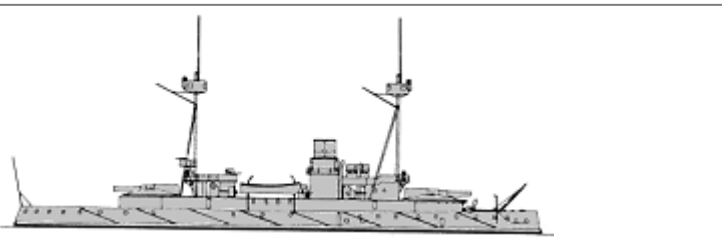
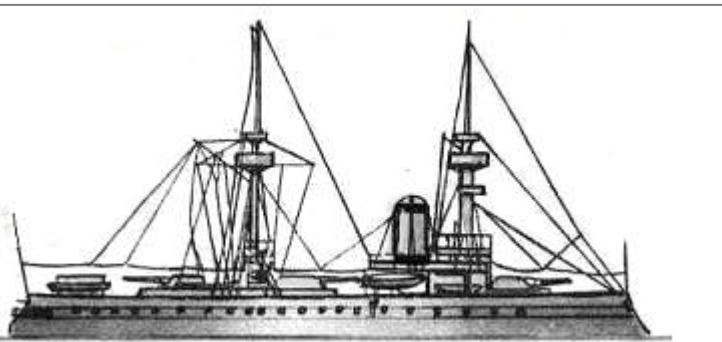
BB	Redoutable	1	6	Redoutable	1878		9224t, 100.7x19.7x7.8m, 8b,1vte, 6200hp, 14.7kts, 705p; iron- 350belt, 60deck, 300battery; 3x1-274/40, 1x1-274/29, 4x1-240/30, 6x1-100/45, 5x1-65/50, 14x1-47/40, (5x5+5x1)-37/20, 2-350TT
	Courbet	2	7	Courbet	1886		10450t, 100.2x21.3x8.1(7)-8.2(8)m, 12b,2vc, 8300hp, 15(7)-15.5(8)kts, 689p; iron- 380belt, 60deck, 240battery; 4x1-340/18(7), 4x1-320/25(8), 3x1-274/45(7), 4x1-274/18(8), 6x1-139/28(7), 6x1-139/21(8), 4x1-65/50(7), 2x1-65/50(8), 14x1-47/40(7), 6x1-47/40(8), (19x5+7x1)-37/20(7), (8x5+12x1)-37/20(8), 5-350TT
			8	Dévastation	1882		
	Amiral Duperré	1	9	Amiral Duperré	1883		11030t, 98.9x20.4x8.4m, 12b,2vc, 7300hp, 14kts, 660p; iron- 560belt, 60deck, 300barbettes, 40CT; 3x1-340/21, 5x1-165/28, 14x1-139/21, 2x1-65/50, 22x1-47/40, (18x5+18x1)-37/20, 4-350TT
	Terrible	4	10	Terrible	1887		7530t, 85.3x18.0x8.0m, 12b,2vc(10-12)-10b,2vc(13), 6500hp, 14.5(10-12)-15(13)kts, 373p; steel(10)- compound(11-13)- 500belt, 105deck, 450barbettes, 30CT; 2x1-340/35(10), 2x1-420/22(11-13), 4x1-100/26, 4x1-47/40(10), 2x1-47/40(11-13), 16x5-37/20, 4-350TT
			11	Indomptable	1887		
			12	Caïman	1888		
			13	Requin	1888		
	Amiral Baudin	2	14	Amiral Baudin	1888		11720t, 101.0x21.3x8.5m, 12b,2vc, 8400(14)-9700(15)hp, 15(14)-16(15)kts, 625(14)-650(15)p; steel/compound- 550belt, 100deck, 400barbettes, 120CT; 2x1-370/28, 8x1-165/30, 8x1-139/45(14), 10x1-139/28(15), 2x1-65/50(14), 20x1-47/40(14), 1x1-47/40(15), 12x5-47/20(15), (2x5+6x1)-37/20(14), 18x5-37/20(15), 4-380TT
			15	Formidable	1889		
							10580t, 102.6x20.2x8.3m, 16b,2vte, 12000hp, 16.5kts, 611p; compound- 450belt, 100deck,

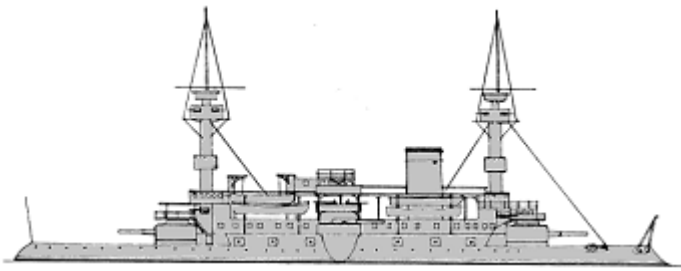
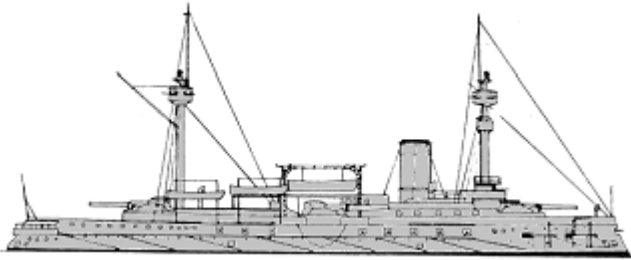
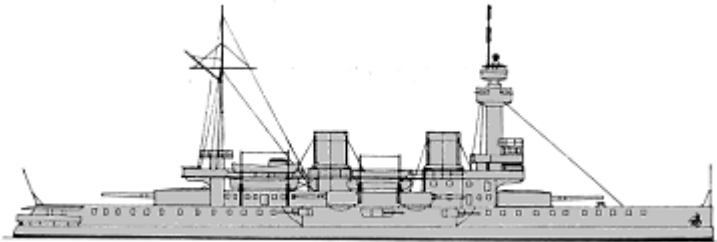
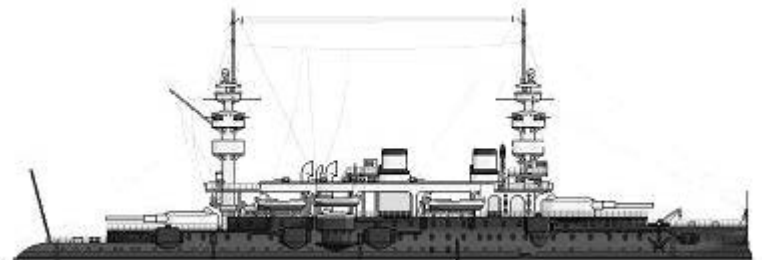
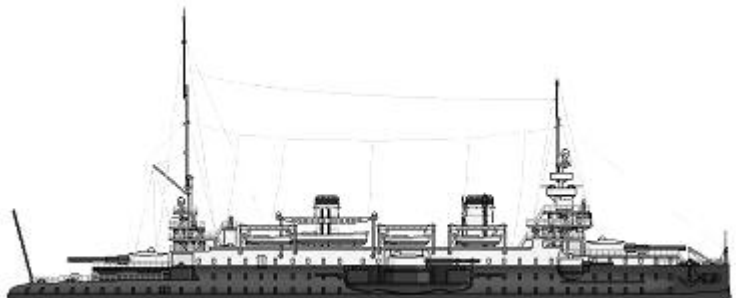
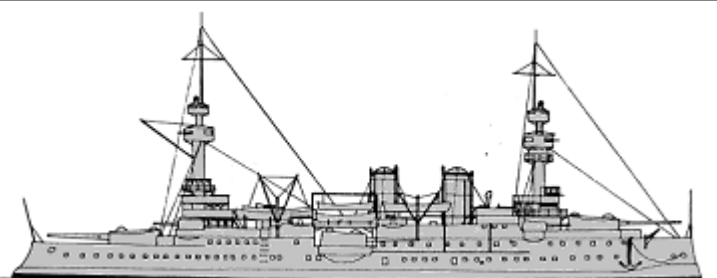
Hoche	1	16	Hoche	1890		400turrets, 65CT; 2x1-340/29, 2x1-274/29, 12x1-139/45, 4x1-65/50, 10x1-47/40, 10x5-37/20, 3-380TT
Marceau	3	17	Marceau	1891		10558(17)-10810(18)-10680(19)t, 101.6x20.2(17)-20.0(18,19)x8.2-8.4m, 8b,2vc(17,19)-12b,2vc(18), 11000hp, 16kts, 643-651p; compound(17,18)-steel(19)- 450belt, 90deck, 400barbettes, 150CT; 4x1-340/29, 16x1-139/30(17), 17x1-139/30(18,19), 3x1-65/50(17), 6x1-65/50(18,19), 9x1-47/40(17), 18x1-47/40(18,19), 8x5-37/20(17), 12x5-37/20(18,19), 3-380TT(17), 5-380TT(18,19)
		18	Neptune	1892		
		19	Magenta	1893		
Brennus	1	20	Brennus	1896		11190t, 114.0x20.4x8.3m, 32b,2vte, 13900hp, 18kts, 673p; steel/compound- 450belt, 80deck, 450turrets, 150CT; (1x2+1x1)-340/42, 10x1-165/45, 4x1-65/50, 14x1-47/40, (8x1+6x5)-37/20, 4-450TT
Charles Martel	1	21	Charles Martel	1897		11693t, 119.0x21.6x8.4m, 24b,2vte, 14900hp, 18kts, 644p; nickel steel- 450belt, 70deck, 380turrets, 230CT; 2x1-305/45, 2x1-274/45, 8x1-139/45, 4x1-65/50, 12x1-47/40, 8x5-37/20, 4-450TT
Carnot	1	22	Carnot	1897		11954t, 119.0x21.4x8.4m, 24b,2vte, 16300hp, 17.8kts, 647p; nickel steel- 450belt, 70deck, 380turrets, 230CT; 2x1-305/45, 2x1-274/45, 8x1-139/45, 4x1-65/50, 12x1-47/40, 8x5-37/20, 4-450TT
Jauréguiberry	1	23	Jauréguiberry	1897		11637t, 111.9x22.2x8.4m, 24b,2vte, 14400hp, 17.7kts, 631p; nickel steel- 450belt, 70deck, 380turrets, 230CT; 2x1-305/45, 2x1-274/45, 4x2-139/45, 4x1-65/50, 12x1-47/40, 8x5-37/20, 4-450TT
		24	Charlemagne	1897		

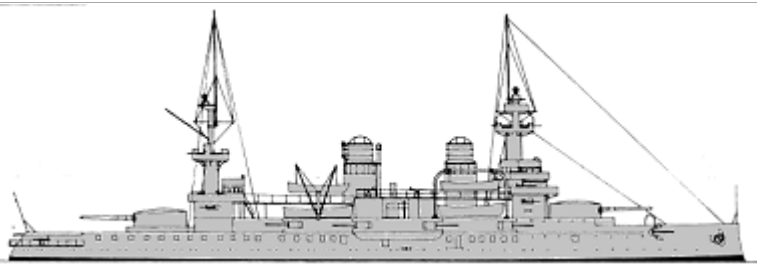
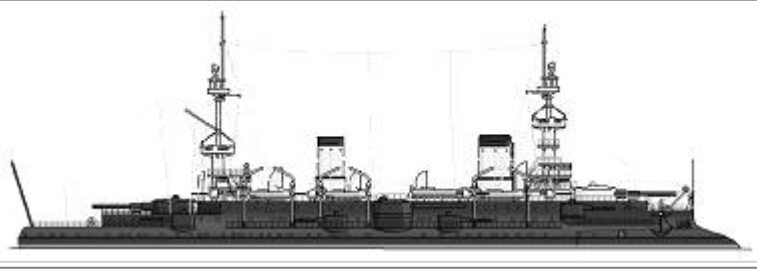
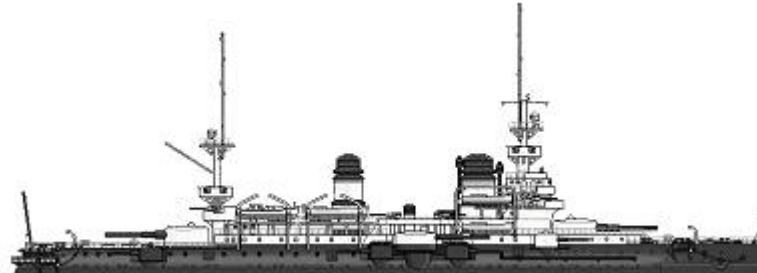
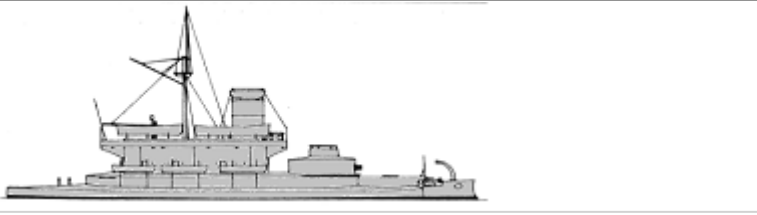
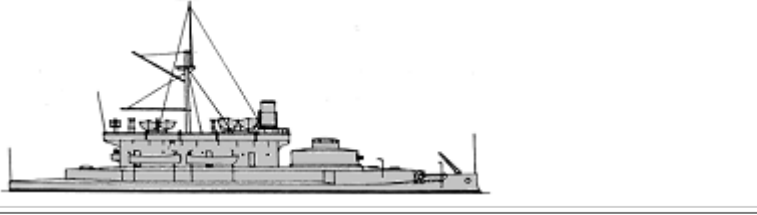
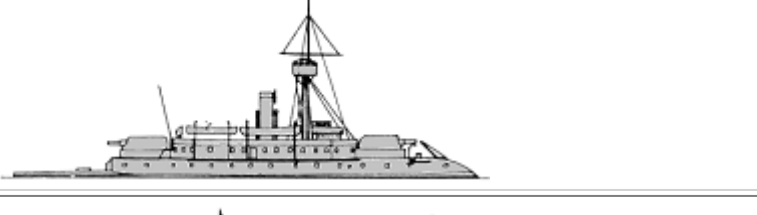
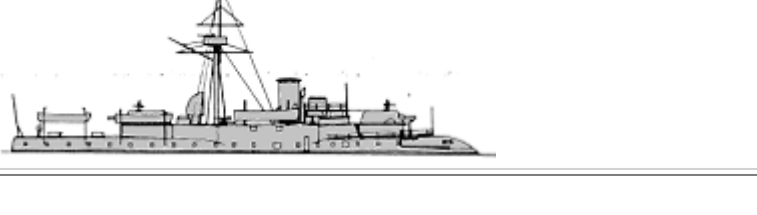
BC	Charlemagne	2	25	Gaulois	1899		11300t, 117.7x20.2x8.4m, 20b,3vte, 15000hp, 18kts, 694p; Harvey- 400belt, 90deck, 380turrets, 330CT; 2x2-305/40, 10x1-139/45, 8x1-100/45, 20x1-47/40, 4x1-37/20, 4-450TT
	Masséna	1	26	Masséna	1898		11735t, 115.5x20.3x8.8m, 24b,3vte, 14200hp, 17kts, 667p; nickel steel- 450belt, 110decks, 400turrets, 350CT; 2x1-305/40, 2x1-274/45, 8x1-139/45, 8x1-100/45, 12x1-47/40, (3x5+5x1)-37/20, 4-450TT
	Bouvet	1	27	Bouvet	1898		12007t, 122.6x21.4x8.4m, 32b,3vte, 15000hp, 18kts, 666p; Harvey- 400belt, 70decks, 380turrets, 300CT; 2x1-305/40, 2x1-274/45, 8x1-139/45, 8x1-100/45, 12x1-47/40, (2x5+5x1)-37/20, 4-450TT
	Tonnerre	1		Tonnerre	1879		5765(1)-5871(2)t, 76.0x17.6x6.5-7.2m, 8b,1hc, 4200-4500hp, 13.7kts, 220p; iron- 330belt, 50deck, 330turret; 1x2-274/20, 4x1-47/40, 4x5-37/20(1), 6x5-37/20(2)
		2	2	Fulminant	1882		
	Tempête	3		Tempête	1879		4793(3)-4635(4)t, 76.0x17.6x5.8m, 4b,1hc(3)-4b,2hc(4), 2000hp, 11.7(3)-10.7(4)kts, 174p; iron- 330belt, 50deck, 350turret; 1x2-340/18(4), 1x2-274/20(3), 2x1-47/40(4), 4x5-37/20(3), 6x5-37/20(4), 2-350TT(4)
		2	4	Vengeur	1882		
Tonnant	1	5	Tonnant	1884		5010t, 75.8x17.8x5.3m, 4b,1hc, 2000hp, 11.6kts, 175p; iron- 450belt, 50deck, 370barbettes; 2x1-340/18, 8x5-37/20	
Furieux	1	6	Furieux	1887		5925t, 75.9x17.8x7.1m, 8b,2vc, 4600hp, 13kts, 235p; steel- 450belt, 90deck, 450barbettes; 2x1-340/21, 4x1-47/40, 10x5-37/20, 2-350TT	
		7	Jemmapes	1894			

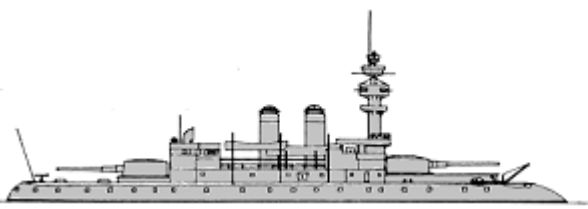
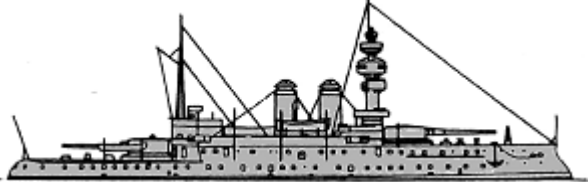
Jemmapes	2	8	Valmy	1894		6476t, 89.7x17.5x7.1m, 16b,2hte, 9000hp, 16.7kts, 313p; NS- 450belt, 100deck, 450turrets, 100CT; 2x1-340/42, 4x1-100/45, 4x1-47/40, 10x5-37/20, 2-450TT
		9	Amiral Tréhouart	1896		
Amiral Tréhouart	2	10	Bouvines	1894		6681t, 89.7x17.8x7.1m, 16b,2vte, 8500hp, 16.5-17kts, 343-362p; NS- 450belt, 110deck, 450turrets, 100CT; 2x1-305/45, 8x1-100/45, 4x1-47/40, 10x5-37/20(9), (8x5+4x1)-37/20(10), 2-450TT

CRUISERS

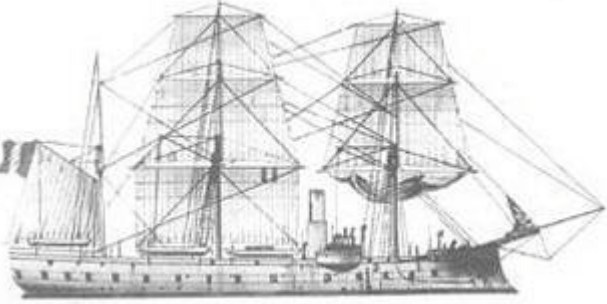
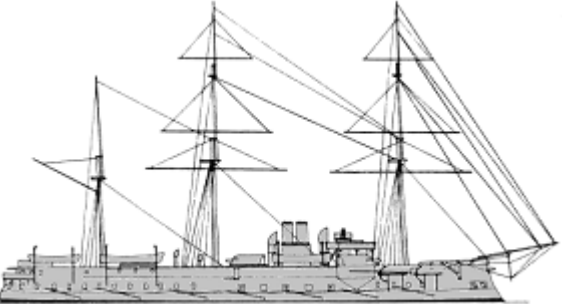
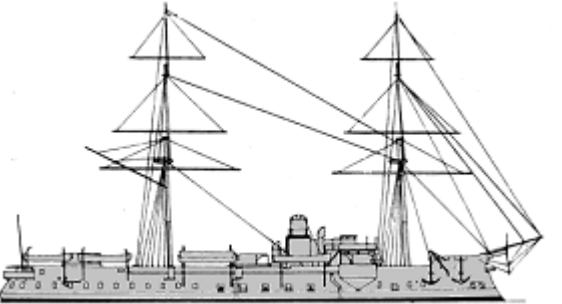
CA	La Galissonnière	2	1	Triomphante	1879		4585t, 78.6x14.9x7.4m, 4b,1vc, 2400hp, 12.7kts, 382p; iron- 150belt, 120barbettes; 6x1-240/18, 1x1-194/20, 6x1-139/21, 8x5-37/20, 4-350TT(1)
			2	Victorieuse	1877		
	Bayard	1	3	Turenne	1882		6260t, 81.0x17.5x7.7m, 8b,2vc, 4400hp, 14kts, 451p; iron- 250belt, 50deck, 200barbettes; 4x1-240/18, 2x1-194/20, 6x1-139/21, 4x1-47/40, 12x5-37/20, 2-350TT
	Vauban	2	4	Duguesclin	1886		6112t, 81.0x17.5x7.7m, 8b,2vc, 4400hp, 14-14.5kts, 440p; iron- 250belt, 50deck, 200barbettes; 4x1-240/18, 1x1-194/20, 6x1-139/21, 4x1-47/40(5), 12x5-37/20, 2-350TT
			5	Vauban	1885		
Amiral Charner	4	6	Amiral Charner	1894		4681-4736t, 110.0x14.0x6.0m, 16b,3hte(6,8,9)-16b,3vte(7), 8000(6,8,9)-8700(7)hp, 18.2(6,8,9)-19(7)kts, 393p; steel- 90belt, 40deck, 110turrets, 110CT; 2x1-194/45, 6x1-139/45, 4x1-65/50, 4x1-47/40, 6x5-37/20, 4-450TT	
7	Bruix	1896					
8	Chanzy	1894					
9	Latouche-Tréville	1895					

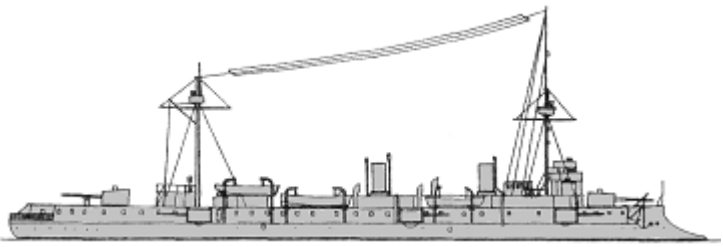
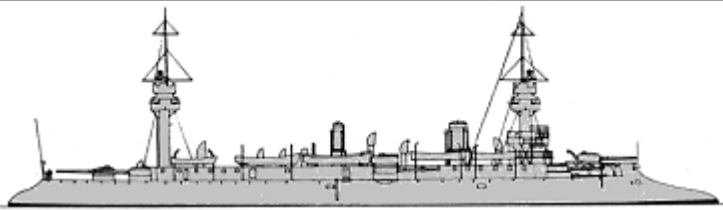
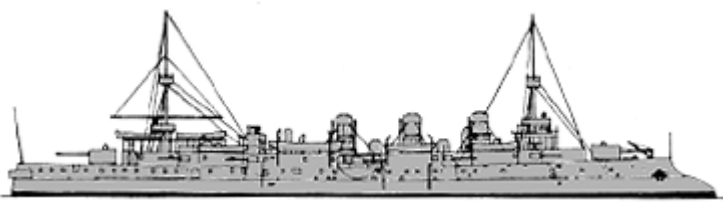
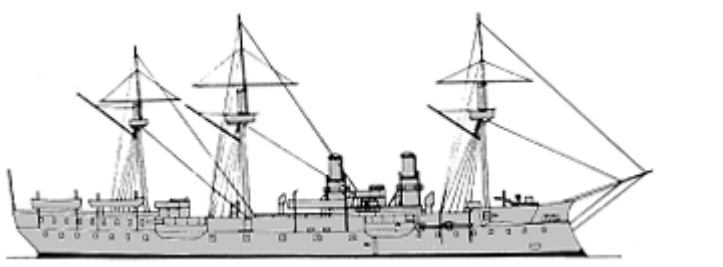
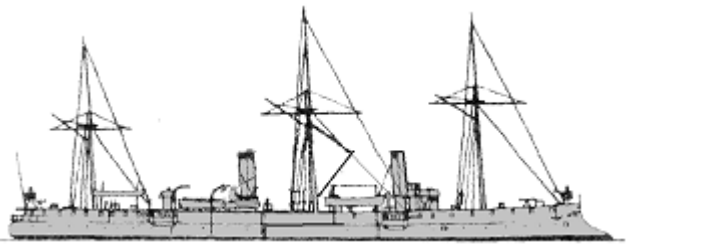
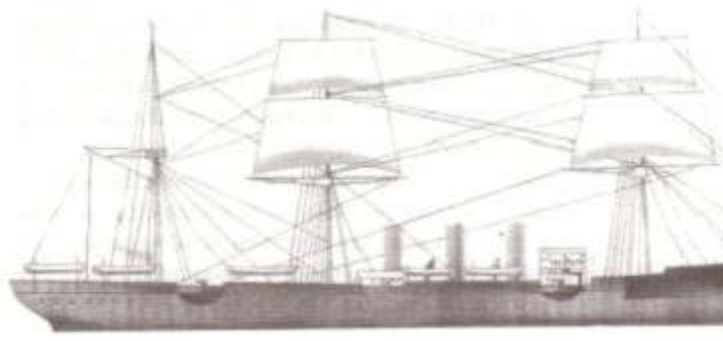

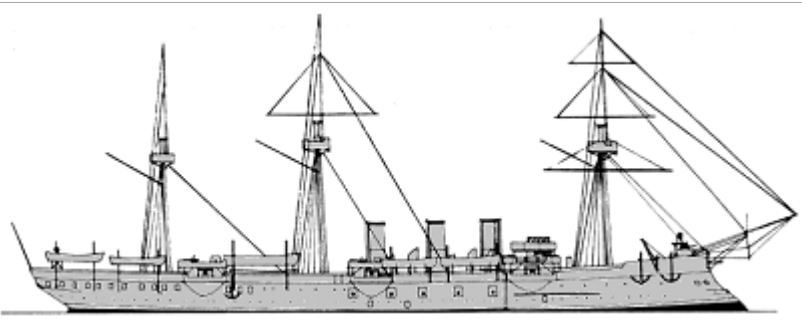
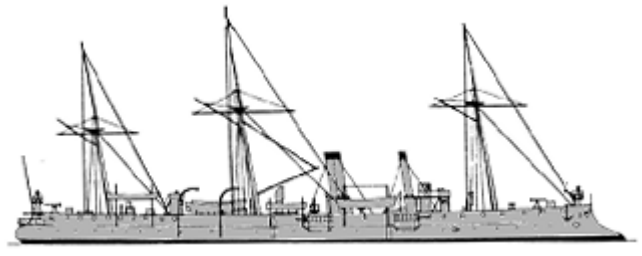
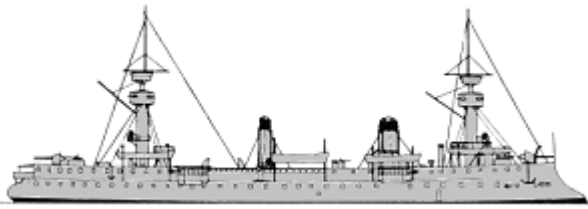
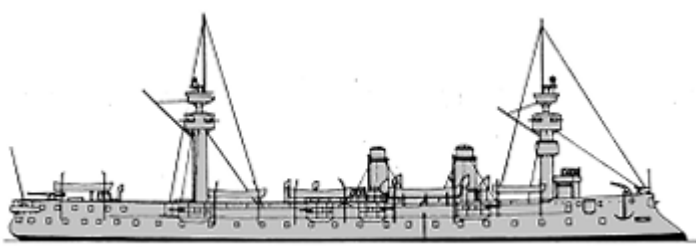
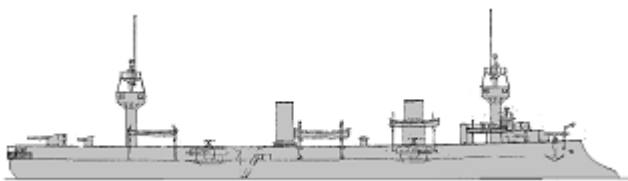
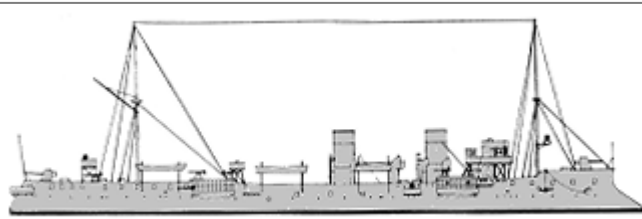
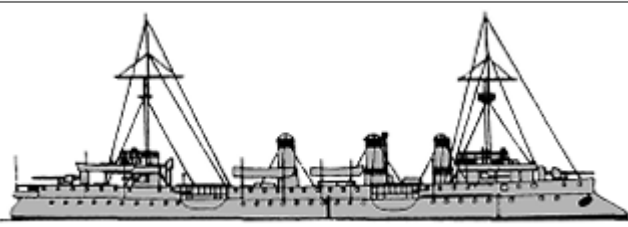
						
Dupuy de Lôme	1	10	Dupuy de Lôme	1895		6676t, 114.0x15.7x7.5m, 13b,2hte+1vte, 13000hp, 19.7kts, 526p; steel- 100belt, 20deck, 200turrets, 130CT; 2x1-194/45, 6x1-165/45, 4x1-65/50, 8x1-47/40, 8x5-37/20, 2-450TT
Pothuau	1	11	Pothuau	1897		5374t, 113.0x15.3x6.5m, 18b,2vte, 10000hp, 19kts, 459p; NS- 60belt, 35deck, 170turrets, 230CT; 2x1-194/40, 10x1-139/45, 10x1-47/40, 8x1-37/20, 4-450TT
Sfax	1	1	Sfax	1887		4561t, 91.6x15.0x7.7m, 12b,2hc, 6500hp, 16.7kts, 486p; steel- 60deck, 25CT; 6x1-165/28, 10x1-139/30, 6x1-47/40, (4x5+6x1)-37/20, 2-350TT
Forbin	2		Forbin	1889		1935(2)-2012(3)-1901(4)t, 95.0x9.0x5.2m, 6b,2hc, 5800hp, 20-20.5kts, 199p; steel- 40deck, 20CT(3); 4x1-139/30, 3x1-47/40, 4x5-37/20, 4-350TT, 150mines
	3		Surcouf	1890		
	4		Coëtlogon	1894		
Tage	1	5	Tage	1890		7469t, 118.9x16.3x7.7m, 12b,2hte, 12500hp, 19.2kts, 538p; steel- 55slopes, 50deck, 90CT; 8x1-165/30, 10x1-139/30, 5x1-47/40, 1x5-47/20, 14x5-37/20, 7-380TT
						5839t, 115.5x15.0x6.8m, 12b,4vc(2), 10200hp, 19.4kts, 517p; steel- 100slopes,

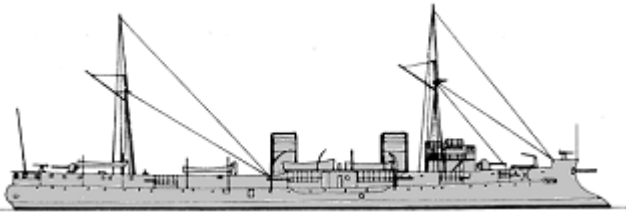
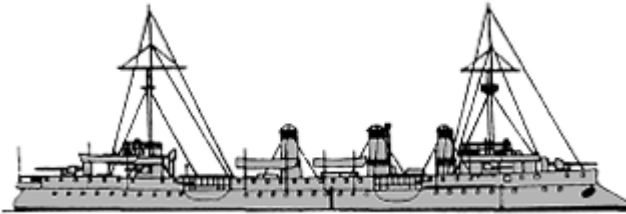
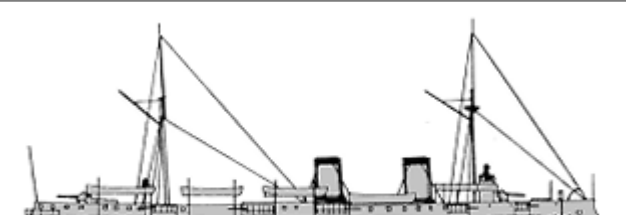
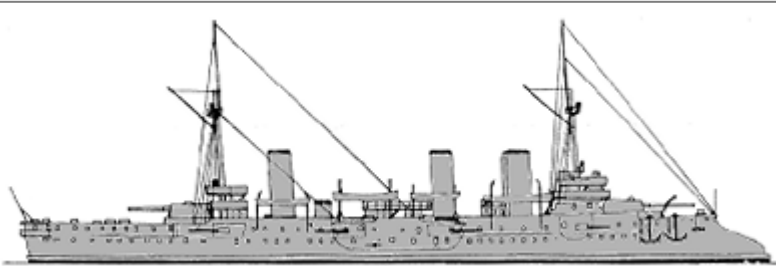
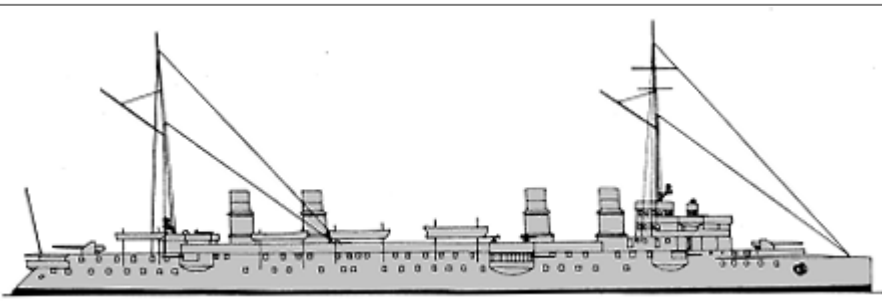
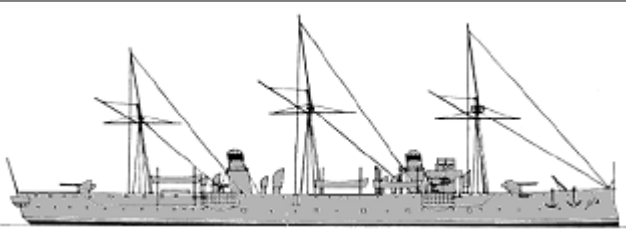
CL	Amiral Cécille	1	6	Amiral Cécille	1890		55deck, 90CT; 8x1-165/30, 10x1-139/30, 6x1-47/40, 14x5-37/20, 4-380TT
	Troude	7		Cosmao	1891		1923(7)-1968(8)-1994(9)t, 95.0x9.0x5.2m, 5b,2hc, 5800hp, 20.5kts, 201p; steel- 40deck, 25CT(8,9); 4x1-139/30, 10x1-47/40, 4x1-37/20, 150mines
		8		Lalande	1890		
		9		Troude	1891		
	Davout	1	10	Davout	1891		3031t, 88.0x12.0x6.6m, 8b,2ite, 9000hp, 20.7kts, 329p; steel- 100slopes, 50deck, 70CT; 6x1-165/30, 4x1-65/50, 4x1-47/40, 2x1-37/20, 6-350TT
	Alger	11		Alger	1891		4313(11)-4406(12)-4044(13)t, 107.0x13.0x6.1-6.5m, 24b,2vte(11)-8b,2hte(12,13), 8000hp, 19(11)-19.5(12,13)kts, 387(11)-405(12,13)p; steel- 100slopes, 50deck, 50shields(12,13), 50(11)-75(12,13)CT; 4x1-165/28, 6x1-139/30, 2x1-65/50, 8x1-47/40(11), 12x1-47/40(12,13), 8x5-37/20(11), 10x5-37/20(12,13), 5-350TT
		12		Isly	1893		
		13		Jean Bart	1891		
	Suchet	1	14	Suchet	1894		3362t, 97.0x12.0x6.1m, 24b,2hte, 9500hp, 20.4kts, 335p; steel- 100slopes, 80deck, 70CT; 6x1-165/30, 4x1-100/45, 8x1-47/40, 8x1-37/20, 7-350TT
	Linois	15		Linois	1895		2285(15)-2318(16,17)t, 98.0(15)-100.6(16,17)x10.6(15,17)-11.0(16)x5.4m, 6b,2vte(15)-16b,2vte(16,17), 6800hp, 20.5kts, 201p; steel- 40deck, 75shields, 125CT; 4x1-139/45, 2x1-100/45, 8x1-47/40, (4x5+2x1)-37/20, 4-450TT(15), 2-450TT(16,17), 120mines(15,16)
16			Galilée	1897			
17			Lavoisier	1898			
Friant	18		Friant	1895		3982(18)-3824(19)-3809(20)t, 97.0x13.0x6.3m, 20b,2vte(18,19)-24b,2vte(20), 9500hp, 18.7kts, 339p; steel- 80slopes, 30deck, 50shields, 75CT; 6x1-165/45, 4x1-100/45, 4x1-47/40, 11x1-37/20, 2-350TT	
	19		Chasseloup-Laubat	1895			
	20		Bugeaud	1896			

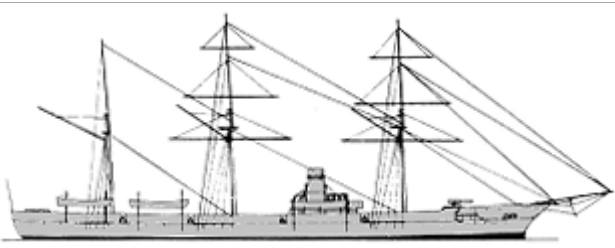
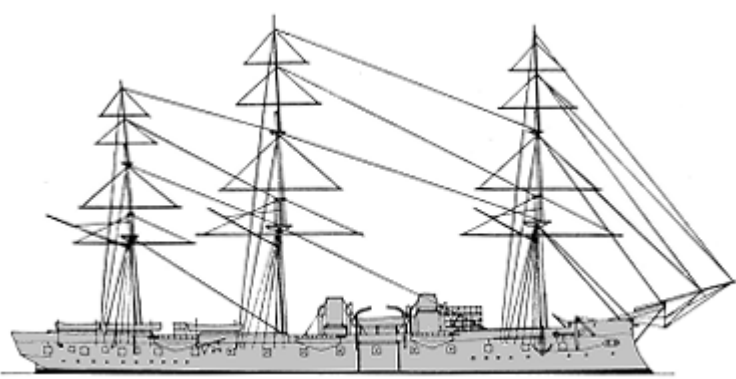
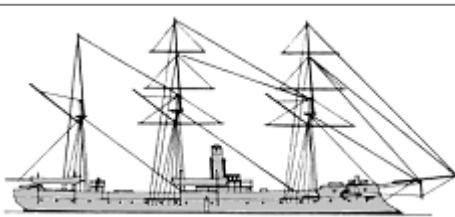
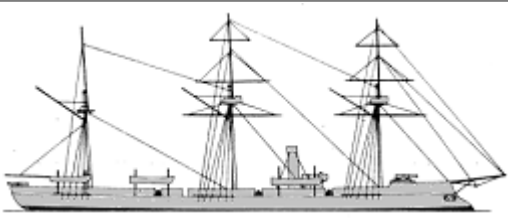
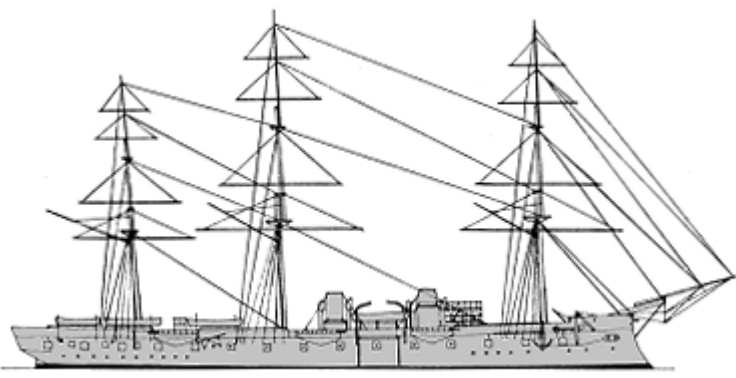
Descartes	21	Descartes	1896		3960t, 99.0x13.0x6.5m, 16b,2vte, 8500hp, 19.5kts, 383(21)-401(22)p; steel-60slopes, 45deck, 50shields, 70CT; 4x1-165/45, 10x1-100/45, 8x1-47/40(21), 14x1-47/40(22), 4x1-37/20(21), 8x1-37/20(22), 2-450TT
	22	Pascal	1897		
D'Assas	23	Cassard	1898		3890(23,25)-3962(24)t, 99.0x13.7x6.3m, 20b,2vte, 10000hp, 20kts, 370-392p; 100slopes, 70deck, 50shields, 100CT; 6x1-165/45, 4x1-100/45, 10x1-47/40, 9x1-37/20(23,25), 5x1-37/20(24), 2-450TT
	24	D'Assas	1898		
	25	Du Chayla	1898		
Catinat	26	Catinat	1898		4048(26)-4001(27)t, 101.0x13.6x6.4m, 16b,2vte, 9500hp, 19.5(26)-20(27)kts, 400p; steel- 60slopes, 45deck, 50shields, 70CT; 4x1-165/45, 10x1-100/45, 10x1-47/40, 4x1-37/20, 2-350TT, 50mines
	27	Protet	1899		
D'Entrecasteaux	1 28	D'Entrecasteaux	1899		8142t, 120.0x17.8x7.5m, 5b,2vte, 14500hp, 19.2kts, 559p; Harvey- 100slopes, 55deck, 250turrets, 250CT; 2x1-240/40, 12x1-139/30, 12x1-47/40, 6x1-37/20, 6-450TT
Guichen	1 29	Guichen	1899		8151t, 139.0x17.0x7.5m, 36b,3vte, 25000hp, 23.5kts, 604p; Harvey- 100slopes, 55deck, 60casemates, 160CT; 2x1-165/45, 6x1-139/45, 10x1-47/40, 5x1-37/20, 2-450TT
D'Estrées	1 30	D'Estrées	1899		2428t, 95.0x12.0x5.4m, 8b,2vte, 8500hp, 20.5kts, 235p; steel- 43deck; 2x1-139/45, 4x1-100/45, 8x1-47/40, 2x1-37/20
Infernet	1 1	Laclocherie	1874		2042t, 79.9x10.9x5.7m, 4b,1hc, 2000hp, 15kts, 205p; 10x1-139/21, 8x5-37/20

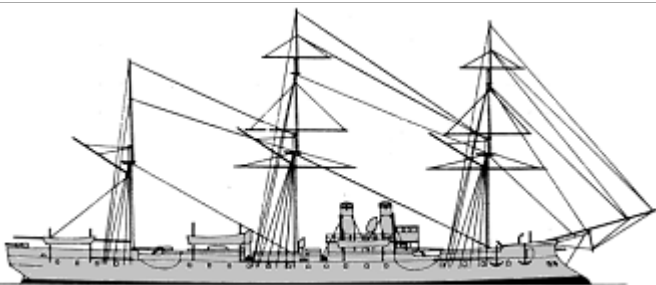
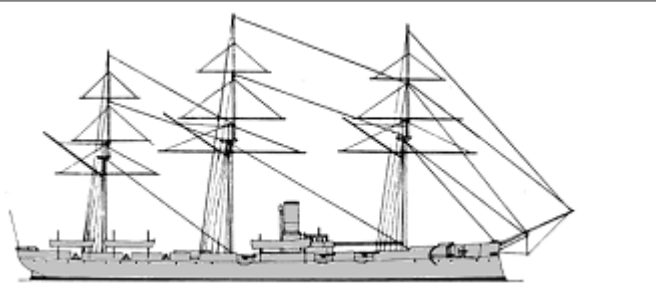
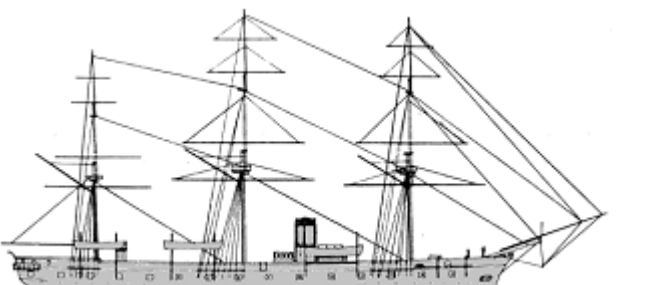
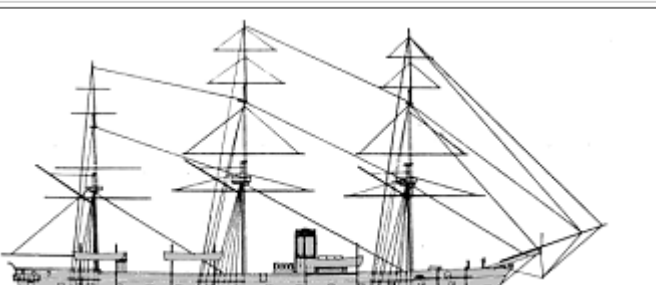
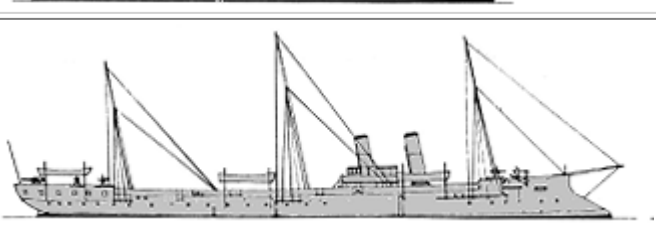

					
Tourville	1 2	Tourville	1877		5698t, 98.6x15.4x7.9m, 12b,1hc, 7460hp, 16.9kts, 540p; 7x1-165/28, 14x1-139/21, 1x1-90/36, 10x1-47/40, 8x5-37/20
Parseval	1 3	Amiral Parseval	1880		856t, 60.8x8.6x4.0m, 2b,1hc, 800hp, 11.4kts, 119p; 4x1-139/21, 5x5-37/20
Rigault de Genouilly	1 4	Éclaireur	1879		1800t, 73.9x10.8x5.5m, 6b,1hc, 2400hp, 15kts, 194p; 8x1-139/21, 8x5-37/20
Duquesne	1 5	Duquesne	1878		5905t, 100.4x15.2x8.0m, 12b,1hc, 8000hp, 16.8kts, 551p; 7x1-194/20, 14x1-139/21, 1x1-90/36, 11x1-47/40, 8x5-37/20
Duguay-Trouin	1 6	Duguay-Trouin	1879		3479t, 89.8x13.2x6.3m, 8b,1hc, 4800hp, 15.5kts, 322p; 5x1-165/28, 5x1-139/21, 4x1-47/40, 5x5-37/20, 2-350TT



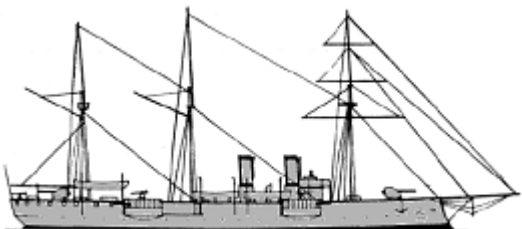





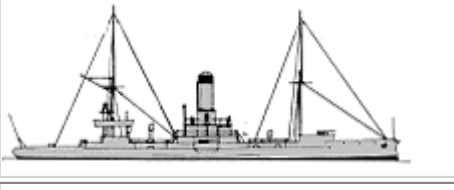
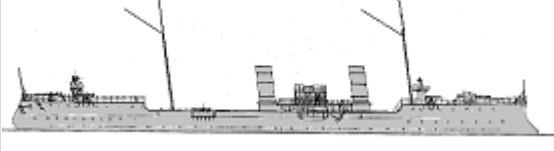
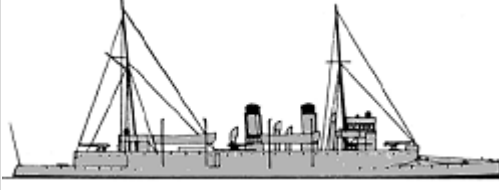

CLL

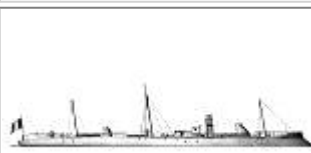



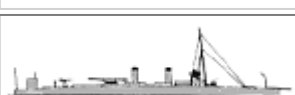

						
Lapérouse	3	7	D'Estaing	1881		2363t, 81.9x11.4x5.7-5.9m, 6b,1hc, 2750hp, 15kts, 264p; 15x1-139/21, 1x1-90/36, (8-10)x5-37/20
		8	Nielly	1882		
		9	Primauguet	1884		
Naïade	1	10	Naïade	1882		3637t, 74.4x14.3x7.2m, 8b,1hc, 2800hp, 14.7kts, 439p; 2x1-165/28, 18x1-139/21, 2x1-100/27, 8x5-37/20
Iphigénie	1	11	Iphigénie	1883		3346t, 73.2x14.2x6.8m, 6b,1hc, 2780hp, 14kts, 435p; 2x1-165/21, 18x1-139/21, 2x1-100/27, 8x5-37/20, 1-350TT
Milan	1	12	Milan	1885		1705t, 92.1x10.0x4.8m, 12b,2hc, 4000hp, 18.4kts, 194p; 2x1-100/26, 12x1-47/40, 2-350TT
Inconstant	3	13	Inconstant	1887		877(13,14)-898(15)t, 61.3x8.0x4.2m, 6b,1hc(13,15)-4b,1hc(14), 1100hp, 12(13,14)-13.8(15)kts, 116p; 3x1-139/30, 1x1-100/26, 5x5-37/20
		14	Papin	1887		
		15	Fulton	1888		

Kersaint	1	16	Kersaint	1898		1276t, 68.6x10.5x4.6m, 4b,1vte, 2400hp, 16kts, 146p; 1x1-139/45, 5x1-100/45, 7x1-37/20
----------	---	----	----------	------	---	--

TORPEDO SHIPS

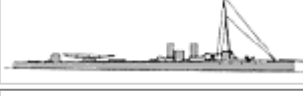
PGT	Condor	4	1	Condor	1886		1229(1)-1268(2)-1311(3)-1266(4)t, 68.0ppx9.0x4.7m, 4b,2ic(1-3)-4b,2hc(4), 3000hp, 17.5(1)-17(2-4)kts, 137p; steel- 40deck; 5x1-100/26, 4x1-47/40, 6x5-37/20
			2	Épervier	1887		
			3	Faucon	1887		
			4	Vautour	1889		
	Wattignies	2	5	Wattignies	1892		1280t, 68.0ppx8.9x4.8m, 4b,2hte(5)-8b,2hte(6), 4000hp, 18.5(5)-18(6)kts, 162(5)-173(6)p; steel- 40deck; 5x1-100/26, 6x1-47/40, 4x1-37/20
			6	Fleurus	1898		
	Bombe	8	7	Bombe	1887		369-430t, 59.2ppx6.0x3.2m, 4b,2vc, 1800hp, 18-19kts, 70p; steel- 13CT; 2x1-47/40, 5x1-37/20, 2x1-350TT
			8	Couleuvrine	1887		
			9	Dague	1888		
			10	Dragonne	1888		
			11	Flèche	1888		
			12	Lance	1890		
			13	Sainte-Barbe	1890		
	Lévrier	2	15	Léger	1891		503t, 63.0x7.0x3.2m, 6b,2vte, 2400hp, 89p; 1x1-65/50, 3x1-47/40, 2x1-37/20, 2x1-450TT
			16	Lévrier	1891		
	D'Iberville	3	17	D'Iberville	1894		952(17)-970(18,19)t, 81.9x8.1(17)-8.2(18,19)x3.5m, 8b,2vqe(17,18)-8b,2vte(19), 5000hp, 21.5-22kts, 143(17)-140(18,19)p; steel- 20belt(18,19), 40slopes(17), 20deck(18,19), 40CT(17); 1x1-100/45, 3x1-65/50, 6x1-47/40(17), 7x1-47/40(18,19), 2x1-450TT(18,19)
			18	Cassini	1895		
			19	Casabianca	1896		
	Dunois	2	20	Dunois	1898		889t, 78.0x8.4x3.9m, 8b,2vte, 7500hp, 21.7-22kts, 137p; steel- 25belt, 10deck, 50CT; 6x1-65/50, 6x1-47/40
			21	La Hire	1899		
		1	Durandal	1899			

DD	Durandal	2					296t, 57.6x6.3x3.2m, 2b,2vte, 4800hp, 26kts, 52p; 1x1-65/50, 6x1-47/40, 2x1-380TT
			2	Hallebarde	1899		
TB	Balny	9	1-9	Balny, Déroulède, Doudart de la Grée, Edmond Fontaine, Bouet Willaumez, Dehorter, Capitaine Cuny, Capitaine Mehl, Challier	1886		65t, 40.7x3.3x1.2m, 1b,1cr, 580hp, 19kts, 22p; 2x5-37/20, 2-350TT
	Coureur	3	10	Coureur	1888		125(10)-131(11,12)t, 44.9(10)-45.1(11,12)x4.3(10)-4.4(11,12)x1.4m, 2b,2vcr(10)-2b,2vte(11,12), 1500(10)-1750(11,12)hp, 23.5kts; 2x1-47/40, 2-350TT
			11	Véloce	1892		
			12	Grondeur	1892		
	Ouragan	5	13	Ouragan	1889		177t, 46.7x4.8x1.8m, 2b,1vqe, 1400hp, 16kts, 29-32p; 2x1-47/40, 4x1-350TT
			14	Alarme	1889		
			15	Téméraire	1889		
			16	Aventurier	1889		
			17	Défi	1889		
	Agile	6	18	Agile	1889		119(18-21)-129(22,23)t, 43.6(18-21)-44.2(22,23)x4.6x1.1m, 1b,1vte(18)-2b,1vte(19-23), 1100hp, 27kts; 3x5-37/20, 3x1-350TT(18-20), (1+1x1)-380TT(21-23)
			19	Eclaire	1891		
			20	Kabyle	1892		
			21	Orage	1892		
			22	Sarrazin	1894		
			23	Tourbillon	1894		
	Avant-Garde	6	24	Archer	1893		128(24)-127(25,26)-129(27-29)t, 42.0pp(24)-41.9pp(25-29)x4.5x1.3m, 2b,2cr(24)-2b,2vte(25-29), 1250(24)-1750(25-29)hp, 20.5(24)-21(25-29)kts, 27p; 2x1-47/40, (1+1x1)-350TT
			25	Turco	1892		
			26	Zouave	1892		
			27	Dragon	1892		
			28	Grenadier	1892		
			29	Lancier	1893		
	Corsaire	1	30	Corsaire	1893		168t, 50.5x4.5x1.7m, 2b,2vte, 2500hp, 25.5kts; 2x5-37/20, 2x1-380TT
	Mousquetaire	1	31	Mousquetaire	1893		123t, 48.0x4.7x1.3m, 2b,2vte, 2100hp, 24.5kts; 2x5-37/20, 2x1-450TT
Chevalier	1	32	Chevalier	1894		135t, 43.8x4.5x1.5m, 2b,2vte, 2200hp, 24.5kts; 2x5-37/20, 2x1-450TT	
Argonaute	2	33	Argonaute	1894		129t, 42.9x4.5x1.7m, 2b,2vte, 2000hp, 23.5kts, 27p; 2x1-47/40, (1+1x1)-380TT	
		34	Tourmente	1894			
Averne	2	35	Averne	1894		131t, 43.9x4.6x1.3m, 2b,2vte, 1750hp, 23.5kts; 2x1-47/40, (1+1x1)-380TT	
		36	Dauphin	1894			
Filibustier	2	37	Ariel	1895		123t, 42.0x4.5x1.7m, 2b,2vte, 2000hp, 23.5kts; 2x1-47/40, (1+1x1)-380TT	
		38	Aquilon	1896			



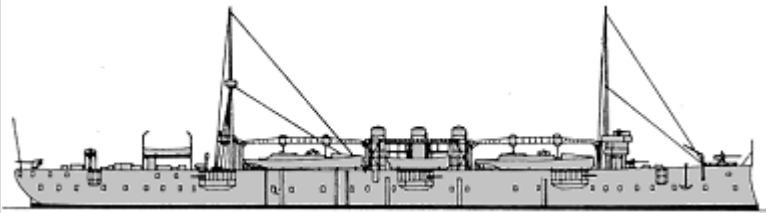

	Forban	1	39	Forban	1896		150t, 44.0x4.6x1.4m, 2b,2vte, 3260hp, 29kts, 29p; 2x1-37/20, 2x1-350TT
	Mangini	1	40	Mangini	1897		140t, 45.0ppx4.7x1.5m, 2b,2vte, 2100hp, 24kts, 27p; 2x1-47/40, (1+1x1)-380TT
	Lansquenet	1	41	Lansquenet	1898	No picture	197t, 52.2x5.3x1.7m, 4b,2vte, 2500hp, 22kts; 2x5-37/20, 2x1-450TT
	Cyclone	1	42	Cyclone	1899		150t, 46.4x4.7x1.5m, 2b,2vte, 4200hp, 29kts; 2x1-47/40, 1x2-380TT
TB2cl	No22	7	1-7	No37-40, 51-53	1879-1880	No picture	33t, 27.0x3.6x0.9m, 1b,1vcr, 320-500hp, 18kts; 2-350TT
	No24	8	8-15	No24, 25, 33-36, 43, 44, 50	1879-1880	No picture	32-35t, 26.0x3.6x0.8m, 1b,1vcr, 320-500hp, 18kts; 2-350TT
	No20	2	16,17	No54,55	1881	No picture	32-35t, 26.0x3.3x0.9m, 1b,1vcr, 320hp, 18kts; 2-350TT
	No26	1	18	No26	1878	No picture	44t, 34.2x3.6x0.8m, 1b,1vcr, 500hp, 18kts, 11p; 2x5-37/20, 2x1-350TT
	No27	1	19	No27	1879	No picture	43t, 31.8x3.3x0.9m, 1b,1vcr, 500hp, 18kts, 12p; 1x2-380TT
	No28	1	20	No28	1879	No picture	43t, 34.5x3.7x0.8m, 1b,1vcr, 500hp, 18kts, 11p; 1x2-380TT
	No29	4	21-24	No56-59	1881-1882	No picture	11(21,22)-9(23,24)t, 18.3x2.3x0.6m, 1b,1cr, 12kts, 12p; 1-350TT(21,22), 2-350TC(23,24)
	No31	2	25,26	No31,32	1879	No picture	27t, 27.0x3.3x0.8m, 1b,1cr, 500hp, 19kts; 2-350TT
	No60	15	27-41	No60-74	1882-1885	No picture	45t, 33.0x3.3x1.1m, 1b,1vcr, 500hp, 20kts, 11p; 4x5-37/20(35), 2-380TT(27-31), 2-350TT(32-35, 36-41)
	No75	51	42-92	No75-125	1887-1889	No picture	53t, 35.0ppx3.4x0.9m, 1b,1vcr, 525hp, 20kts, 16p; 2x5-37/20, 2-380TT
	No126	4	93-96	No126-129	1889-1890	No picture	78t, 36.0x3.9x1.2m, 1b,1vcr, 900hp, 21kts, 21p; 2x5-37/20, 2x1-380TT
	No130	14	97-110	No130-132, 134-144	1890-1892		52t, 34.0ppx3.5x0.9m, 1b,1vte, 720hp, 20kts, 18p; 2x1-37/20, 1x1-380TT, 1spar torpedo
	No145	25	111-135	No145-149, 152-171	1891-1893		78t, 35.9ppx3.9x1.2m, 1b,1vte(111-124,134,135)-2b,1vte(125-133), 1000hp, 21kts, 22-23p; 2x5-37/20, (1+1x1)-380TT
	No172	29	136-164	No172-200	1892-1895		78t, 35.9pp(136-155)-36.9pp(156-165)x3.9x1.2m, 2b,1vte(136-145,152-155)-1b,1vte(146-151,156-164), 1350hp, 22(136-158)-23(159-164)kts, 22-23p; 2x5-37/20, (1+1x1)-380TT
	A	8	165-172	A, B, D, E, F, G, H, I	1894-1898	No picture	14t, 18.5x3.0x1.4m, 1b,1cr, 250hp, 17kts; 1-350TT
C	1	173	C	1894	No picture	14t, 19.0x2.9x1.5m, 1b,1vc, 20.5kts; 1-350TT	
No201	28	174-201	No201-212, 216-222, 227, 230-234, 236-238	1897-1899		83-90t, 37.0x4.2x1.2m, 2b,1vte, 1500(174-184, 194-201)-1800(185-193)hp, 24kts, 23p; 2x5-37/20, (1+1x1)-380TT	

CTB	Foudre	1	1	Foudre	1897		6089t, 118.7x17.2x7.1m, 24b,2vte, 11500hp, 19kts, 410p Harvey- 120slopes, 60deck, 55shields, 120CT; 8x1-100/45, 4x1-65/50, 4x1-37/20, 10TBs
-----	--------	---	---	--------	------	--	---

SUBMARINES

SS	Gymnôte	1	1	Gymnôte	1888		32/33t, 18.4x1.8x1.7m, 1em, 90hp, 7.3/4.3kts, 5p, 20m; 2-350TC
	Gustave Zédé	1	2	Gustave Zédé	1898		266/272t, 48.5x3.2x3.2m, 1em, 208hp, 19p, 30m; 1-450TT

OTHER FIGHTING SHIPS

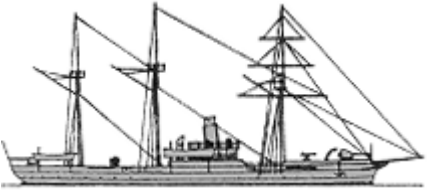
PG	Fusée	4	1	Flamme	1887		1073-1124t, 50.3x9.9x3.2m, 3b,2vc, 1500hp, 12.5kts, 89p; compound(1,4)-steel(2,3)- 240belt, 50deck, 200barbette; 1x1-240/29, 1x1-90/28, 4x5-37/20
			2	Fusée	1885		
			3	Grenade	1889		
			4	Mitraille	1888		
	Achéron	4	5	Achéron	1888		1690(5,6)-1767(7,8)t, 55.2(5,6)-58.7(7,8)x12.3x3.6m, 4b,2hc, 1600hp, 11.6-13kts, 110p; compound- 200belt, 50deck, 200turret; 1x1-274/29, 1x1-139/28(7,8), 2x1-100/26(5), 3x1-100/26(6), 2x1-47/40, 4x5-37/20(5,6), 7x5-37/20(7,8)
			6	Cocyste	1890		
			7	Phlégéon	1892		
			8	Styx	1892		
	Crocodile	3	9	Aspic	1880		465-492t, 44.1x7.3x2.9-3.3m, 2b,1hc, 440hp, 10-11kts, 76p; 2x1-139/21, 2x1-90/36, (2-4)x5-37/20
			10	Capricorne	1882		
			11	Vipère	1881		
	Comète	5	12	Comète	1884		492t, 46.2ppx7.5x3.2m, 2b,1hc, 500hp, 11-12kts, 76p; 2x1-139/21, 2x1-100/27, 3x5-37/20
			13	Gabès	1884		
			14	Lion	1884		
			15	Météore	1885		
			16	Scorpion	1884		
Gabriel Charmes	1	17	Gabriel Charmes	1886	No picture	73t, 41.9x3.8x2.0m, 1b.1vc, 580hp, 19kts, 23p; 1x1-139/30	
Surprise	2	18	Surprise	1896		617-637t, 56.0-56.3ppx7.9-8.0x3.7m, 2b,1hte, 900hp, 13kts, 99p; 2x1-100/45, 4x1-65/50, 4x1-37/20	
		19	Décidée	1898			
Javelot	1	1	Javelot	1866	No picture	89t, 24.8x4.9x1.4m, 2, 45hp, 26p; 1x1-139/17, 1x1-47/40	
		2	Berthe-de-Villers	1884			
		3	Jacquín	1884			

PR	Berthe-de-Villers	5	4	Garnier	1884	No picture	200t, 37.4x7.4x0.9m, w, 36hp, 51p; 2x1-90/28, 4x5-37/20
			5	Henri-Rivière	1884		
			6	Moulun	1884		
	Estoc	3	7	Estoc	1884	No picture	112t, 30.0x5.8x1.1m, 2, 45(7)-35(8,9)hp, 49p; 2x1-90/28, 3x5-37/20
			8	Mutine	1884		
			9	Rafale	1884		
	Niger	2	10, 11	Niger, Mage	1884-1888	No picture	25t; 2x1-37/20
	Doucet	5	12	Bobillot	1885	No picture	120t, 29.6x11.0x0.8m, w, 48p; 1x1-47/40, 4x5-37/20
			13	Cuvellier	1885		
			14	Doucet	1885		
			15	Raynaud	1885		
			16	Rollandes	1885		
	Opale	2	17, 18	Opale, Onyx	1892-1893	No picture	60t, 34p; 2x1-37/20



[home](#)[World navies yesterday](#)[1900](#)

Germany 01 January 1900

BATTLESHIPS

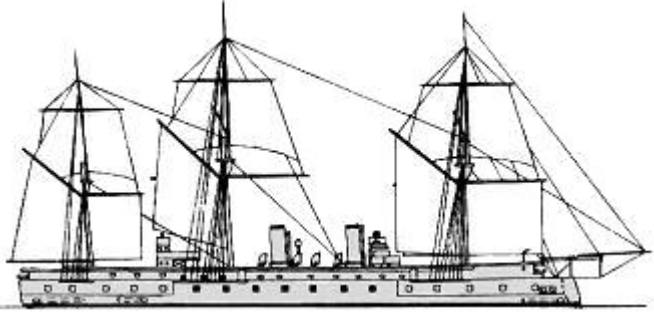
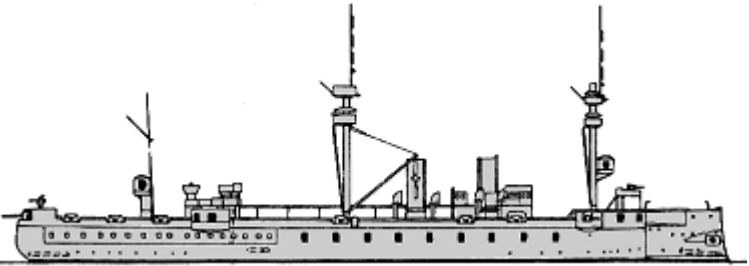
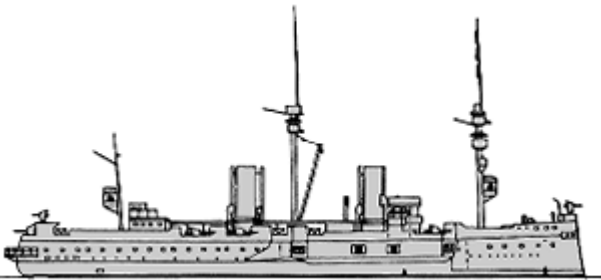
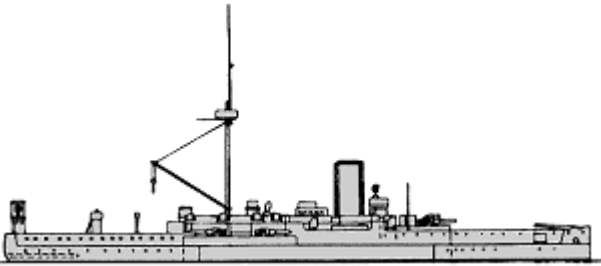
	Kronprinz	1	1	Kronprinz	1867		6760t, 89.4x15.2x7.9m, 8b,1hse, 4870hp, 14.7kts, 541p; iron; 124belt, 121battery, 50CT; 2x1-209/20, 14x1-209/17, 6x5-37/20, 5-350TT
	König Wilhelm	1	2	König Wilhelm	1869		10761t, 112.2x18.3x8.6m, 8b,1hse, 8440hp, 14.7kts, 730p; iron; 305belt, 51deck, 203battery, 100CT; 22x1-238/18, 1x1-149/28, 18x1-88/27, 5-350TT
	Kaiser	2	3	Kaiser	1875		8940t, 89.3x19.1x7.9m, 8b,1hse, 5700hp, 14.5kts, 656p; steel; 254belt, 51deck, 203casemate, 50(3)-100(4)CT; 1x1-149/28(3), 8x1-149/32(4), 6x1-105/32(3), 9x1-88/27(3), 8x1-88/27(4), 4x1-37/42, 5-350TT
			4	Deutschland	1875		
BB	Sachsen	4	5	Sachsen	1878		7742-7938t, 98.2x18.4x6.5m, 8b,2hc, 6201-6454hp, 14.2-15.7kts, 317p; 254belt, 75deck, 254barbettes/citadel, 200CT; 6x1-263/20, 8x1-88/27, 6x1-87/22, 8x5-37/20, 2-450TT, 3-350TT
			6	Bayern	1881		
			7	Württemberg	1881		
			8	Baden	1883		

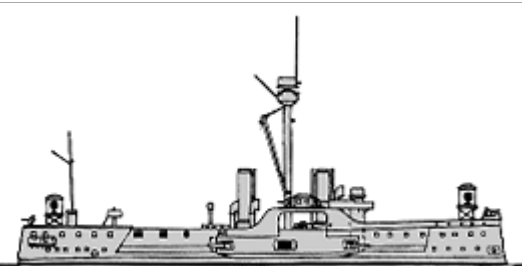
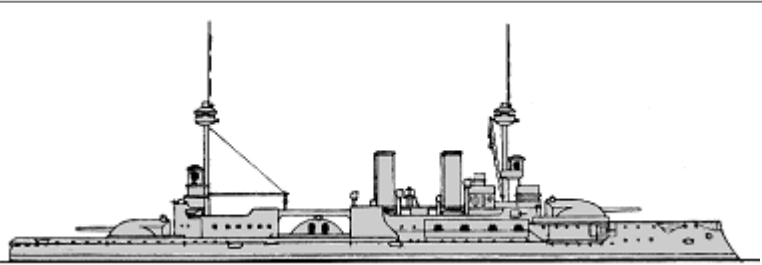
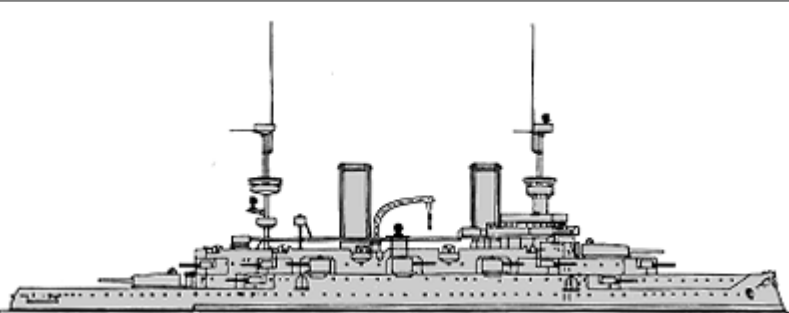
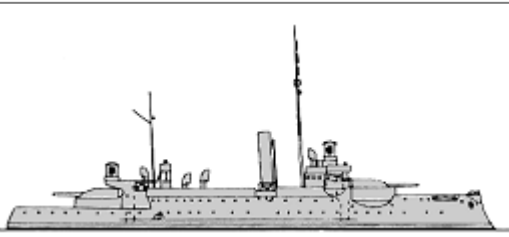
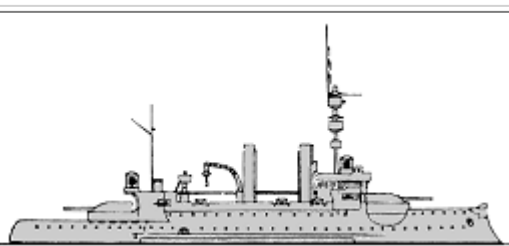
	Oldenburg	1	9	Oldenburg	1886		5743t, 79.8x18.0x6.3m, 8b,2hc, 3942hp, 13.8kts, 389p; compound; 300belt, 30deck, 200battery, 50CT; 8x1-238/28, 4x1-149/20, 6x1-50/37, 4-350TT
	Kurfürst Friedrich Wilhelm	4	10	Kurfürst Friedrich Wilhelm	1894		10670t, 115.7x19.5x7.9m, 12b,2vte, 10000hp, 16.5kts, 568p; compond(10,12); 400belt, 60deck, 300barbettes, 300CT; 2x2-283/37, 1x2-283/32, 6x1-105/32, 8x1-99/27, 6-450TT
11			Brandenburg	1893			
12			Weissenburg	1894			
13			Wörth	1893			
	Kaiser Friedrich III	1	14	Kaiser Friedrich III	1898		11785t, 125.3x20.4x8.3m, 12b,3vte, 13000hp, 17.5kts, 651p; 300belt, 65deck, 250turrets, 250CT; 2x2-238/37, 18x1-150/37, 12x1-88/27, 6-450TT
BC	Siegfried	6	1	Siegfried	1890		3741t, 79.0x14.9x5.7m, 4b,2vte, 5000hp, 14.5kts, 276p; compound; 240belt, 30deck, 200barbettes, 80CT; 3x1-238/32, 8x1-88/27, 4-350TT
			2	Beowulf	1892		
			3	Frithjof	1893		
			4	Heimdall	1894		
			5	Hildebrand	1893		
			6	Hagen	1894		
		Odin	2	7	Odin	1896	
		8	Ägir	1896			

CRUISERS

	Bismarck	5	1	Blücher	1878		3386(1)-2994(2-5)t, 82.5(1)-82.0(2-5)x13.7x6.3m, 4b,1hse, 2500hp, 12.5kts, 404p; 10x1-149/22(2,3), 14x1-149/22(4), 12x1-149/22(5), 2x1-88/27(2-5), 4x1-87/24(1), 13x5-37/20(1), 6x5-37/20(2-5), 3-450TT(1), 4-350TT(1)
			2	Stosch	1878		
			3	Moltke	1878		
			4	Gneisenau	1880		
			5	Stein	1880		

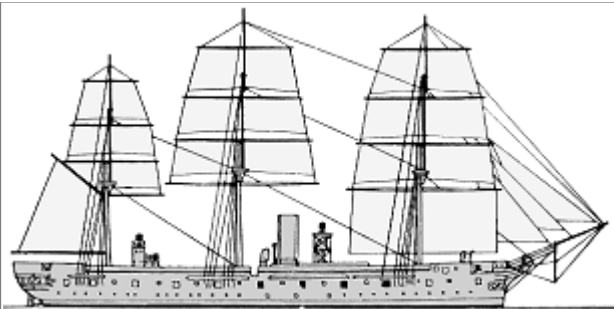
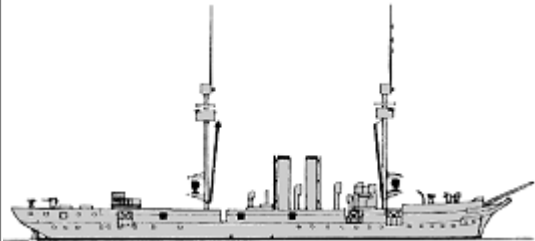
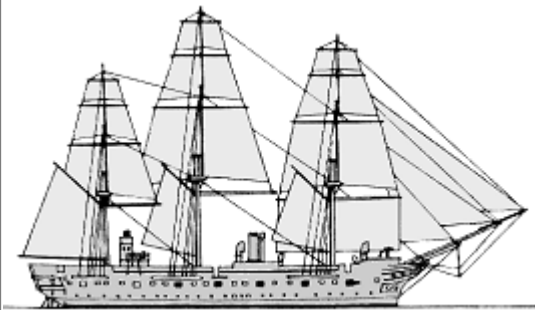
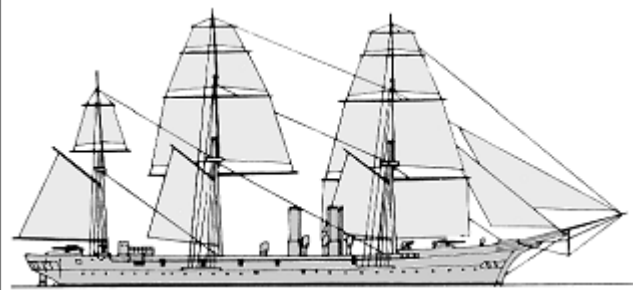
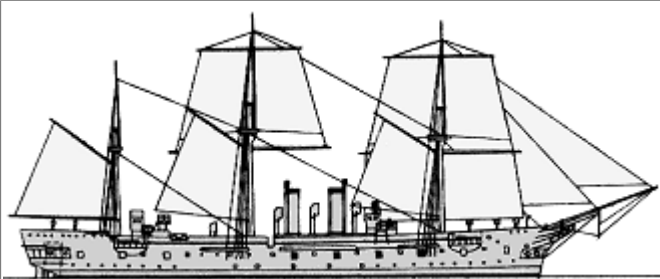
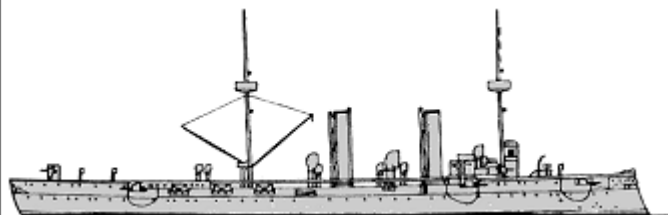



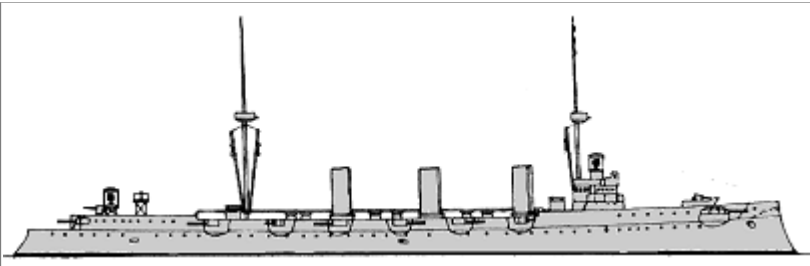
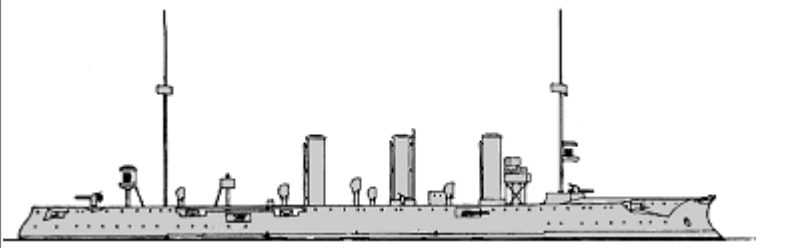
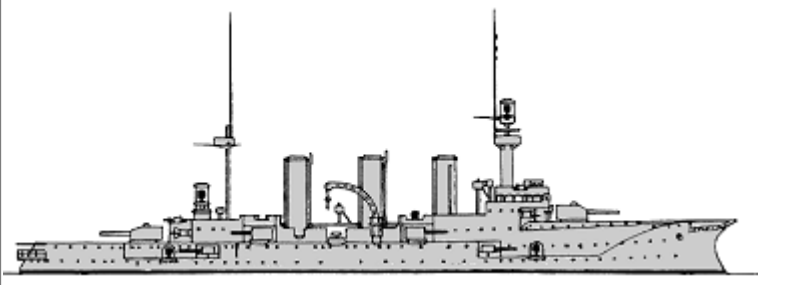
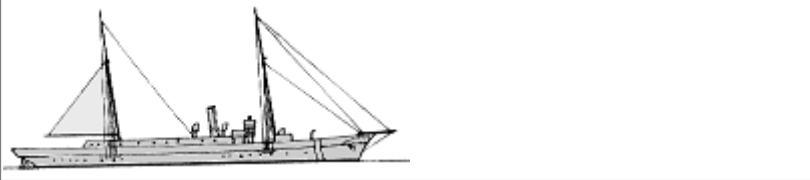
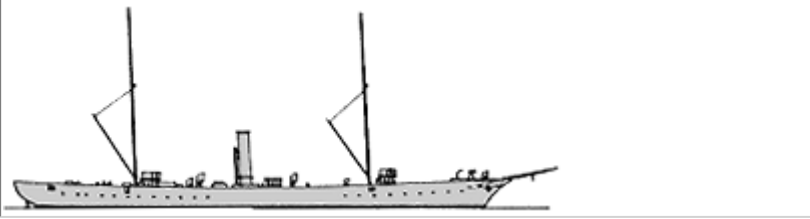
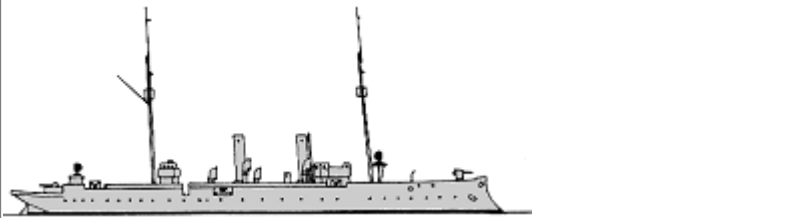
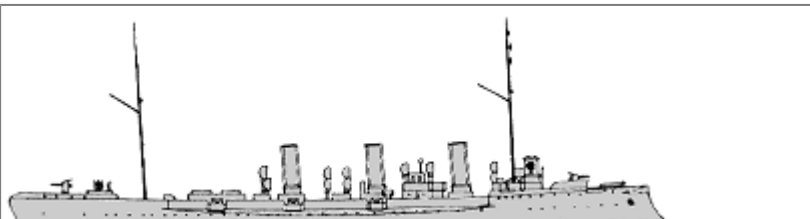

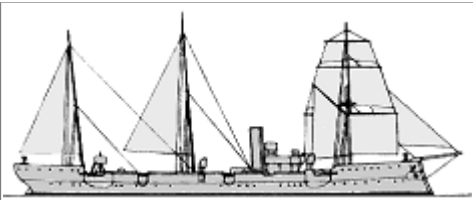
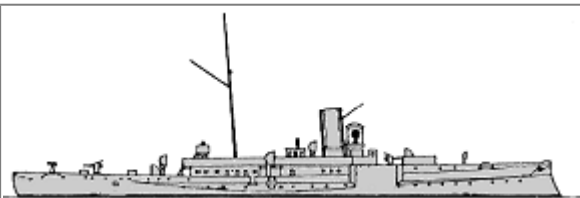
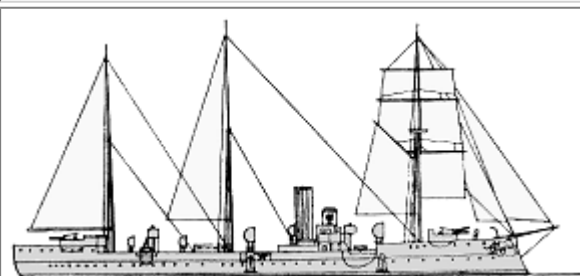
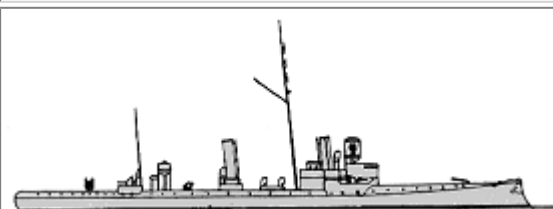
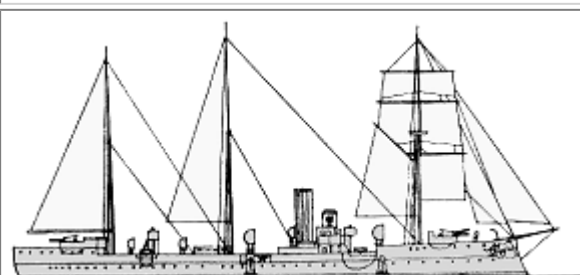
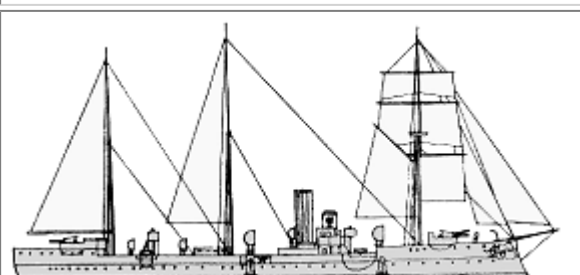
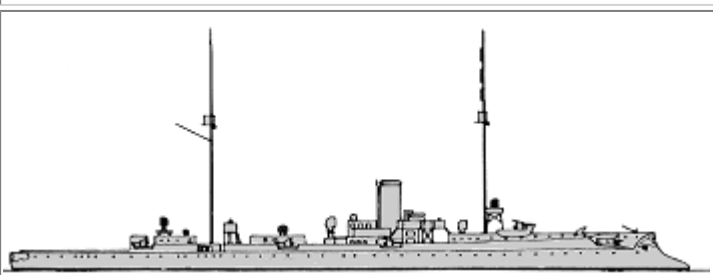

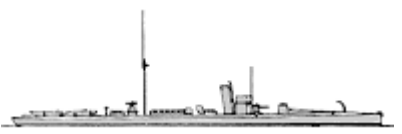

						
Carola	4	6	Carola	1881		2424t, 76.4x12.5x6.1m, 8b,1hc(6,7)-6b,1hc(8,9), 2100hp, 13.5kts, 269p; 6x1-149/20(6), 10x1-149/20(8,9), 2x1-105/32(6), 8x1-88/27(6,8,9), 2x1-87/22(7), 2x1-50/37(6), 10x5-37/20(8,9)
		7	Olga	1881		
		8	Marie	1882		
		9	Sophie	1882		
Nixe	1	10	Nixe	1886		1982t, 63.3x13.2x6.4m, 2b,1hc, 700hp, 9kts, 358p; 6x1-125/21, 2x1-88/27, 4x5-37/20
Alexandrine	2	11	Alexandrine	1886		2662t, 81.2x12.6x6.3m, 8b,1hc, 2400hp, 14kts, 282p; 10x1-149/27, 4x1-105/32, 6x5-37/20
		12	Arcona	1886		
Charlotte	1	13	Charlotte	1886		3763t, 83.9x14.6x6.9m, 8b,1hc, 3000hp, 13kts, 506p; 2x1-105/32, 16x1-88/27, 4x5-37/20
Irene	2	14	Irene	1888		5027t, 103.7x14.2x7.6m, 4b,2hc, 8000hp, 18kts, 365p; compound; 75slopes, 50deck, 50CT; 4x1-149/28, 8x1-105/32, 6x1-50/37, 3-350TT
		15	Prinzess Wilhelm	1889		

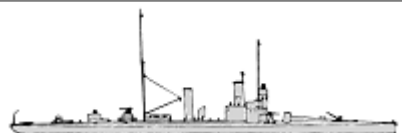

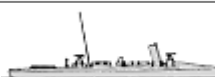

CL

Kaiserin Augusta	1	16	Kaiserin Augusta	1892		6381t, 123.2x15.6x7.4m, 8b,3vte, 12000hp, 21kts, 430p; 70slopes, 50deck, 50CT; 14x1-149/32, 8x1-88/27, 4x5-37/20, 5-350TT
Gefion	1	17	Gefion	1894		4275t, 110.4x13.2x6.5m, 6b,2vte, 9000hp, 19kts, 212p; steel; 25slopes, 30deck, 30CT; 10x1-105/32, 6x1-50/37, 2x1-450TT
Victoria Louise	5	18	Victoria Louise	1899		6491(18-20)-6705(21,22)t, 110.6x17.4(18-20)-17.6(21,22)x6.8-7.3m, 12b,3vte(18-21)-18b,3vte(22), 10000hp, 19.5(18-20)-18.5(21,22)kts, 477p; 100slopes, 40deck, 100turrets, 150CT; 2x1-209/37, 8x1-149/37, 10x1-88/27, 3-450TT
		19	Hertha	1898		
		20	Freya	1898		
		21	Vineta	1899		
		22	Hansa	1899		
Grille	1	1	Grille	1858		491t, 56.9x7.4x3.2m, 2b,1hc, 760hp, 14.4kts, 70p; 1x1-125/21, 2x1-79/25, 6x5-37/20
Zieten	1	2	Zieten	1876		1170t, 79.4x8.6x4.6m, 6b,2hc, 2000hp, 16kts, 94p; 6x1-50/37
Blitz	2	3	Blitz	1883		1486t, 78.4x9.9x4.4m, 8b,2hc, 2700hp, 15.6kts, 134p; 6x1-88/27, (2x1+1)-350TT
		4	Pfeil	1884		
Greif	1	5	Greif	1887		2266t, 102.6x9.8x4.3m, 6b,2hc, 5400hp, 18kts, 170p; 2x1-105/32, 8x1-88/27, 6x5-37/20
		6	Schwalbe	1888		





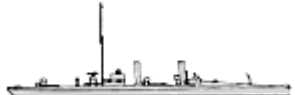

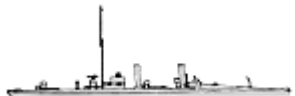
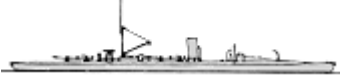
CLL	Schwalbe	2	7	Sperber	1889		1359t, 66.9x9.4x4.7m, 4b,2hc, 1500hp, 13.5kts, 117p; 8x1-105/32, 5x5-37/20
	Wacht	2	8	Wacht	1888		1499t, 85.5x9.7x4.7m, 4b,2dte, 4000hp, 19kts, 141p; compound; 40slopes, 20deck, 25CT; 4x1-88/27, 3-350TT
			9	Jagd	1889		
	Bussard	2	10	Bussard	1890		1868t, 82.6x10.2x5.6m, 4b,2hte, 2800hp, 15.5kts, 161p; 8x1-105/32, 2x1-350TT
			11	Falke	1891		
	Meteor	2	12	Meteor	1891		1078(12)-1117(13)t, 79.9x9.6x4.5m, 4b,2vte, 4500(12)-5000(13)hp, 19(12)-19.5(13)kts, 115p; steel; 25slopes, 15deck, 30CT; 4x1-88/27, 3-350TT
			13	Comet	1893		
	Seeadler	3	14	Seeadler	1892		1864t, 82.6x10.5x5.4m, 4b,2hte, 2800hp, 15.5kts, 161p; 8x1-105/32, 2x1-350TT
15			Condor	1892			
16			Cormoran	1893			
Geier	1	17	Geier	1895		1918t, 83.9x10.6x5.2m, 4b,2hte, 2880hp, 15.5kts, 161p; 8x1-105/32, 2x1-450TT	
Hela	1	18	Hela	1896		2082t, 105.0x11.0x4.6m, 6b,2vte, 6000hp, 20kts, 178p; steel; 25slopes, 20deck, 30CT; 4x1-88/27, 6x1-50/37, (1+2x1)-450TT	

TORPEDO SHIPS

DD	D1	2	1	D1	1887		300t, 56.1x6.6x3.4m, 2b,1vte, 2000hp, 20.6kts, 46p; 3x1-50/37, (1+2x1)-350TT
			2	D2	1887		
	D3	2	3	D3	1888		300t, 57.6x6.8x3.2m, 2b,1vte, 2200hp, 20.3kts, 46p; 3x1-50/37, (1+2x1)-350TT
			4	D4	1888		
	D5	2	5	D5	1889		406t, 59.6x7.4x3.5m, 2b,1vte, 3200hp, 22.6kts, 46p; 3x1-50/37, (1+2x1)-350TT
			6	D6	1889		
	D7	2	7	D7	1891		410t, 59.7x7.4x3.4m, 2b,1vte, 3600hp, 22.5kts, 46p; 3x1-50/37, (1+2x1)-450TT
			8	D8	1891		
	D9	1	9	D9	1894		458t, 63.0x7.7x3.7m, 3b,1vte, 4200hp, 23.5kts, 52p; 3x1-50/37, (1+2x1)-450TT
	D10	1	10	D10	1898		371t, 66.1x6.0x2.4m, 3b,2vte, 5783hp, 27.2kts, 47p; 5x1-50/37, (1+2x1)-450TT
S90	1	11	S90	1899		394t, 63.0x7.0x2.8m, 3b,2vte, 5900hp, 27kts, 57p; 3x1-50/37, 3x1-450TT	
S	Nr. XVIII	8	1-8	V1, 2, 4-9	1884		61t, 32.8x3.8x1.8m, 1b,1vte, 590hp, 17.9kts, 14p; 2x5-37/20, 2-350TT
	Nr. XXVIII	1	9	S2	1884		99t, 37.7x4.9x2.2m, 1b,1vte, 970hp, 19.3kts, 15p; 2x5-37/20, (2+1x1)-350TT
	S7	17	10-26	S7-23	1885		98t, 37.7x4.9x2.2m, 1b,1vte, 725hp, 20.4kts, 16p; 1x1-50/37, (1+2x1)-350TT
	S24	7	27	S24	1886		103t, 37.7x4.8x2.3m, 1b,1vte, 840hp, 19.1kts, 16p; 1x1-50/37, (1+2x1)-350TT
			28	S25	1886		
			29	S27	1886		
			30	S28	1886		
31			S29	1886			
32	S30	1887					
33	S31	1887					
S32	1	34	S32	1886		119t, 39.1x5.3x2.5m, 1b,1vte, 900hp, 19.9kts, 20p; 1x1-50/37, (1+2x1)-350TT	

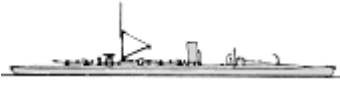
						
S33	8	35	S33	1887		113t, 39.9x4.8x2.3m, 1b,1vte, 1100hp, 20kts, 16p; 1x1-50/37, (1+2x1)-350TT
		36	S34	1887		
		37	S35	1887		
		38	S36	1887		
		39	S37	1887		
		40	S38	1887		
		41	S39	1887		
		42	S40	1887		
S42	1	43	S42	1889		153t, 44.2x5.0x2.6m, 1b,1vte, 1420hp, 22.2kts, 16p; 1x1-50/37, (1+2x1)-350TT
S43	14	44	S43	1889		152t, 44.2x5.0x2.7m, 1b,1vte, 1571hp, 21.5kts, 16p; 1x1-50/37, (1+2x1)-350TT
		45	S44	1889		
		46	S45	1889		
		47	S46	1889		
		48	S47	1889		
		49	S49	1890		
		50	S50	1890		
		51	S51	1890		
		52	S52	1890		
		53	S53	1890		
		54	S54	1890		
		55	S55	1890		
		56	S56	1890		
		57	S57	1890		
S58	8	58	S58	1892		152t, 44.3x5.0x2.6m, 1b,1vte, 1232hp, 20.2kts, 16p; 1x1-50/37, (1+2x1)-350TT
		59	S59	1892		
		60	S60	1892		
		61	S61	1892		
		62	S62	1892		
		63	S63	1892		
		64	S64	1892		
65	S65	1892				
S66	1	66	S66	1893		172t, 47.9x5.4x2.7m, 2b,1vte, 1610hp, 22.1kts, 24p; 1x1-50/37, (1+2x1)-450TT
		67	S67	1893		
		68	S68	1893		
		69	S69	1893		

TB



S67	7	70	S70	1893		166t, 47.9x5.4x2.6m, 1b,1vte, 1600hp, 21.9kts, 24p; 1x1-50/37, (1+2x1)-450TT	
		71	S71	1893			
		72	S72	1893			
		73	S73	1894			
S74	1	74	S74	1895		186t, 49.9x5.5x2.8m, 2b,1vte, 2500hp, 23.7kts, 24p; 1x1-50/37, (1+2x1)-450TT	
S75	7	75	S75	1895		180t, 49.0x5.3x2.9m, 2b,1vte, 1744hp, 22.3kts, 24p; 1x1-50/37, (1+2x1)-450TT	
		76	S76	1895			
		77	S77	1895			
		78	S78	1895			
		79	S79	1895			
		80	S80	1895			
S82	6	82	S82	1897		170t, 48.2x5.1x2.6m, 2b,1vte, 2146hp, 25.3kts, 29p; 1x1-50/37, (1+2x1)-450TT	
		83	S83	1897			
		84	S84	1897			
		85	S85	1898			
		86	S86	1898			
		87	S87	1898			
G88	2	88	G88	1898		177t, 48.7x5.0x2.8m, 2b,1vqe, 2468hp, 26kts, 29p; 1x1-50/37, (1+2x1)-450TT	
		89	G89	1898			
TSS	Ulan	1	1	Ulan	1876		438t, 38.0x8.0x4.6m, 4b,1vse, 800hp, 12kts, 41p; 3x5-37/20, 1-381TT

ESCORTS

PC	Sirius	4	1-4	Sirius, Vega, Castor, Pollux	1889-1890		52t, 22.6x4.6x1.6m, 1b,1vte, 200hp,,
----	--------	---	-----	------------------------------	-----------	---	--------------------------------------

OTHER FIGHTING SHIPS

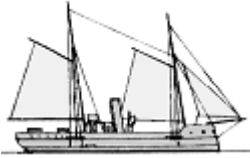
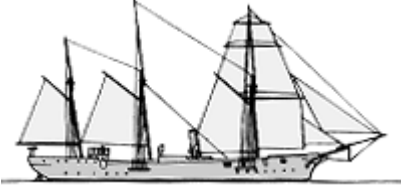
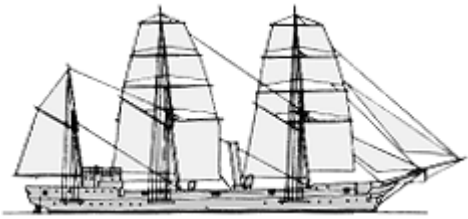
Wespe	11	1	Wespe	1876		1163t, 46.4x10.6x3.4m, 4b,2dc, 700hp, 10kts, 88p; iron- 203belt, 40deck, 203barbette, 20CT; 1x1-305/20, 2x1-87/22, 2x5-37/20, 2-350TT
		2	Viper	1877		
		3	Biene	1877		
		4	Mücke	1878		
		5	Scorpion	1877		
		6	Basilisk	1880		
		7	Camaeleon	1879		

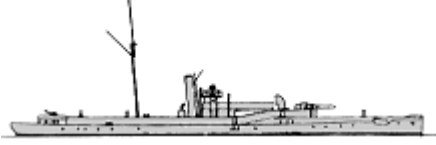
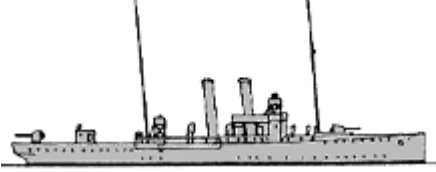
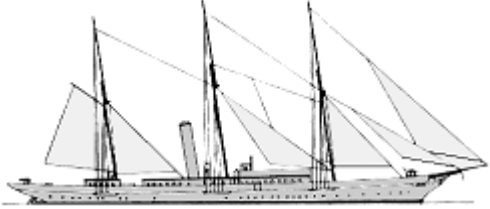
		8	Crocodill	1880		
		9	Salamander	1880		
		10	Natter	1881		
		11	Hummel	1881		
PG	Otter	1	12 Otter	1878		164t, 31.0x6.2x1.6m, 1b,2vse, 140hp, 8kts, 43p; small arms
	Wolf	2	13 Wolf	1878		570t, 47.2x7.7x3.4m, 2b,1hse, 340hp, 8.5kts, 106p; 2x1-125/21(14), 1x1-87/22(13), 2x1-87/22(14), 1x1-50/37(13), 2x5-37/20(13), 3x5-37/20(14)
			14 Hyäne	1879		
	Habicht	2	15 Habicht	1880		1005t, 59.2x8.9x4.2m, 2b,1hc, 600hp, 11kts, 127p; 5x1-125/21(15), 2x1-125/21(16), 5x5-37/20
			16 Möwe	1880		
	Hay	1	17 Hay	1882		247t, 34.0x6.4x2.8m, 2b,1vc, 202hp, 9.3kts, 40p; 2x1-88/27
	Brummer	2	18 Brummer	1884		929t, 64.8x8.5x4.8m, 2b,1dc, 1658(18)-2081(19)hp, 14.1(18)-15.2(19)kts, 78p; compound- 160breastwork, 40deck; 1x1-209/28, 1x1-87/22, 2x5-37/20, 1-350TT
			19 Bremse	1884		
Iltis	2	20 Iltis	1898		1031t, 65.2x9.1x3.6m, 4b,2hte, 1300hp, 14.5kts, 130p; 4x1-88/27	
		21 Jaguar	1899			
APG -	1	1 Lorelei	1886		924t	

MINE WARFARE SHIPS

--	--	--	--	--	--	--

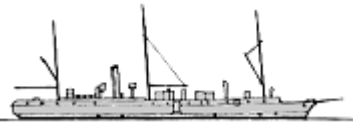
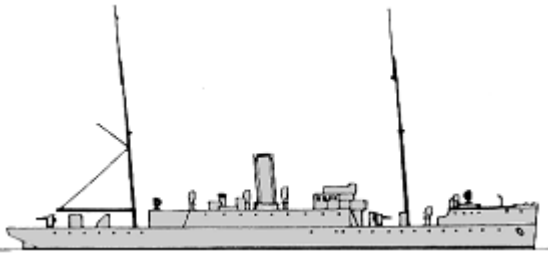
ML	Rhein	1	1	Rhein	1867		482t, 47.1x6.0x3.2m, 1b,1vse, 200hp, 9kts, 81p; 2x5-37/20, 100mines
	Pelikan	1	2	Pelikan	1891		2424t, 84.2x11.7x5.1m, 2b,2vte, 3000hp, 15kts, 195p; 4x1-88/27, 400mines



© Ivan Gogin, 2014

[home](#)[World navies yesterday](#)[1900](#)

Greece 01 January 1900

BATTLESHIPS

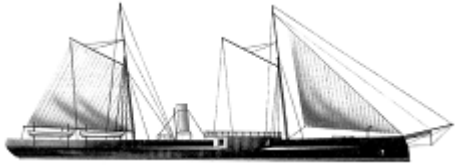
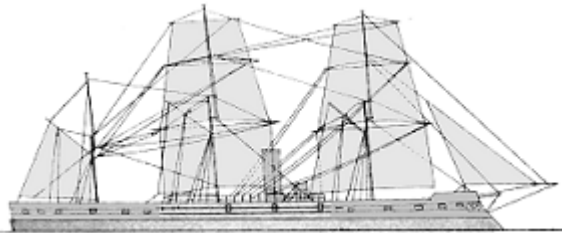
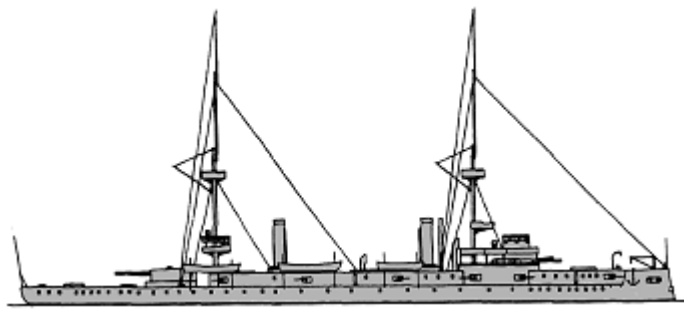
BC	Vasilefs Georgios	1	1	Vasilefs Georgios	1868		1774t, 61.0ppx10.1x4.9m, 4b,2vte, 3000hp, 14kts, 152p; iron- 178belt, 152battery, 25deck; 2x1-209/20, 1x1-149/27, 9x1-37/37
	Vasilissa Olga	1	2	Vasilissa Olga	1870		2030t, 76.0ppx11.9x5.8m, 4b,1vte, 4000hp, 16.5kts, 258p; iron- 152belt, 121battery, 25deck; 4x1-173/22, 2x1-173/17, 4x1-75/35, 4x5-37/17
	Idra		3	Idra	1892		4885t, 102.0ppx15.8x5.5m, 4b,2vte, 6700hp, 17kts, 440p; steel, compound- 305belt, 57deck, 350casemate, 305barbette; 2x1-274/34, 1x1-274/28, 1x1-100/48, 8x1-65/50, 4x1-47/40, 10x5-37/17, 1-381TT, 2-356TT
		4	Spetsai	1892			
		5	Psara	1891			

CRUISERS

CLL	Navarchos Miaoulis	1	1	Navarchos Miaoulis	1879	No picture	1820t, 75.0ppx11.0x4.4m, 1hc, 2400hp, 13.5kts, 180p; 3x1-173/22, 1x1-173/17, 6x1-37/20, 3-356TT
-----	--------------------	---	---	--------------------	------	------------	---

TORPEDO SHIPS

TB	Ionia	2	1, 2	Sfinx, Ionia	1881	No picture	35t, 27.1x3.4x1.0m, 1b,1vc, 500hp, 17.5kts, 9p; 2-356TC
	Fereniki	5	3-7	Fereniki, Terpsihori, Persefoni, Terpsithea, Kalithea	1881	No picture	42t, 30.5x3.7x1.3m, 1b,1vc, 320hp, 16kts, 12p; 2-356TT, 1spar torpedo
	Samos	6	8-13	Samos, Khios, Mitilini, Kos, Rodos, Kipros	1881	No picture	40t, 30.5x3.7x1.3m, 1b,1vc, 450hp, 19.5kts, 12p; 2x5-37/17, 2-356TT
	No11	6	14-19	No11-16	1885		85t, 37.5x4.7x1.7m, 1b,1vc, 1000hp, 18kts, 20p; 1x5-37/17, (2+1x1)-356TT

SUBMARINES

SS	Nordenfelt I	1	1	Nordenfelt I	1885	No picture	60/ t, 19.5x2.7x3.4m, 1b,1vc, 100hp, 9/4kts, 3p; 1x1-25/42, 1-356TT
----	--------------	---	---	--------------	------	------------	---

OTHER FIGHTING SHIPS

PG	Afroessa	2	1	Afroessa	1857	No picture	380t, 38.0x7.0x2.7m, 160hp, 9kts; 1x1-87/22
			2	Plixavra	1857		
	Salaminia	2	3	Paralos	1859	No picture	380t, 37.5x7.3x3.0m, 200hp, 8kts; 1x1-87/22
			4	Salaminia	1859		
	Sfaktiria	4	5-8	Alfa, Beta, Gamma, Delta	1880-1881	No picture	52t, 22.0x4.5x1.5m; 1x1-149/24, 1spar torpedo
	Hydra	2	9	Amvrakia	1881	No picture	470t, 39.0ppx7.9x2.2m, 2vc, 690hp, 12kts, 64p; 1x1-263/27, 1x1-149/27, 2x1-37/20, 1-356TT
			10	Aktion	1881		
	Achelaos	4	11	Achelaos	1884		400-420t, 41.0-42.0x7.4-7.6x3.5-4.0m, vc, 400hp, 9.8(11,12)-10.5(13,14)kts, 73p; 2x1-95/26, 2x1-37/20(11,12), 3x1-37/20(13,14)
			12	Alpheos	1884		
			13	Eurotas	1884		
			14	Peneos	1885		
	Aidon	1	15	Aidon	1884	No picture	86t
	Kichli	2	16, 17	Kichli, Kissa	1884	No picture	86t, 24.2x4.9x2.1m, 1vc, 162hp, 10kts

MINE WARFARE SHIPS

ML	Aigialeia	3	1	Aigialeia	1881	No picture	300t, 23.0x4.0x2.6m, 1vc, 300hp, 9kts; 20mines
			2	Monemvasia	1881		
			3	Nafplia	1881		
AML	-	1	1	Kanaris	1878		870t, 91.2x9.2m, 500hp, 14kts; 2x1-120/22, 2x5-37/17, 4-356TT, mines

© Ivan Gogin, 2014



[home](#)[World navies yesterday](#)[1900](#)

Haiti 01 January 1900

CRUISERS

CL	Dessalines	1	1	Dessalines	1883	No picture	1200t, 56.4x9.8x4.5m, 760hp, 16kts; 2x1-107/29, 1x1-100/26, 2x1-87/22
----	------------	---	---	------------	------	------------	---

OTHER FIGHTING SHIPS

PG	22 Décembre 1804	1	1	22 Décembre 1804	1860	No picture	900t, 63.4x9.1x4.9m, 360hp, 9kts; 4x1-121/22
	1804	1	2	1804	1875	No picture	600t, 44.2x8.8x3.1m, 100hp, 12kts; 6x1-121/22
	Saint Michael	1	3	Saint Michael	1875	No picture	850t, 49.4x10.7x3.4m, 120hp, 12kts; 1x1-279/12, 8x1-102/22
	Toussaint Louverture	1	4	Toussaint Louverture	1886		500t, 50.0ppx7.5x3.3m, 1vc, 790hp, 13kts; 1x1-165/28, 2x1-120/27
	Capois La Mort	2	5	Capois La Mort	1893		256t, 45.0x6.2x2.1m, 680hp, 14kts; 1x1-100/50, 4x1-37/20
			6	Alexander Pétion	1893		
	Crête-à-Pierrot	1	7	Crête-à-Pierrot	1895		950t, 1vte, 16kts; 1x1-165/45, 1x1-120/45, 4x1-100/45

© Ivan Gogin, 2015

[home](#)

[World navies yesterday](#)

[1900](#)

Honduras 01 January 1900

COASTAL FORCES

YP	22 Februar	1	1	22 Februar	1897	No picture	13t, 22hp
----	------------	---	---	------------	------	------------	-----------

© Ivan Gogin, 2015

[home](#)[World navies yesterday](#)[1900](#)

India 01 January 1900

BATTLESHIPS

MON	Abyssinia	1	1	Abyssinia	1870		2901t, 68.6ppx12.8x4.5m, 2drctr, 1200hp, 9.6kts, 100p; iron: 178belt, 38deck, 254turrets; 2x2-203/30
-----	-----------	---	---	-----------	------	--	--

TORPEDO SHIPS

PGT	Sharpshooter	2	1	Assaye	1892		735t, 70.1ppx8.2x3.2m, 4b,2vte, 3600hp, 19kts, 91p; 2x1-120/40, 4x1-47/40, (1+2x1)-356TT
			2	Plassey	1892		



Custom Search

© Ivan Gogin, 2014

[home](#)[World navies yesterday](#)[1900](#)

Italy 01 January 1900

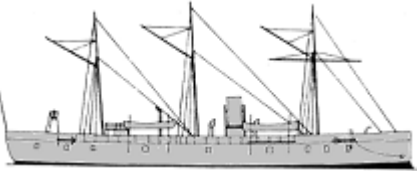
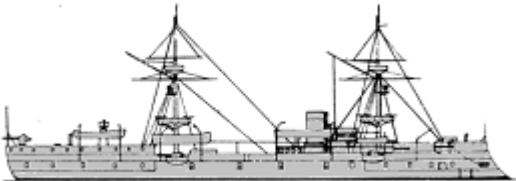
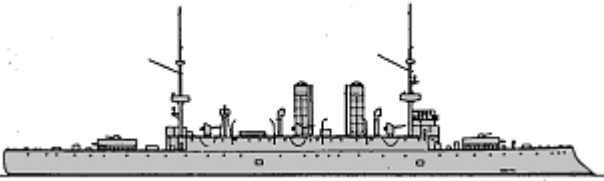
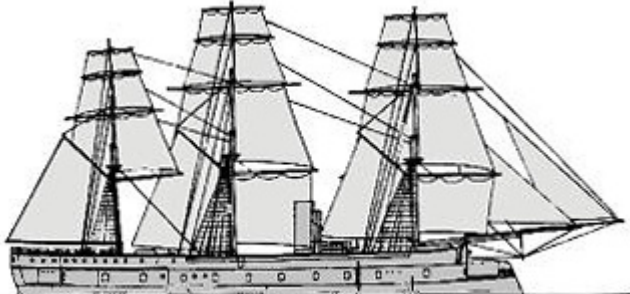
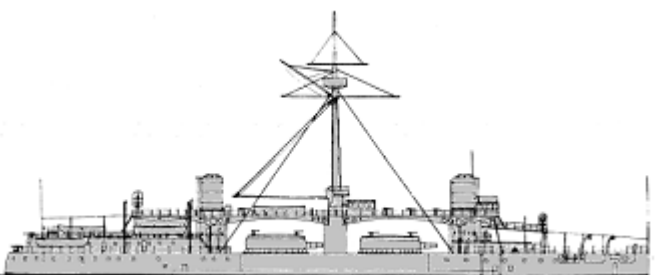
BATTLESHIPS





Formidabile	1	Terribile	1861		2682t, 2807(1)-2618(2)t, 65.8x14.4x5.5m, 6b,1hse, 1100(1)-1080(2)hp, 10kts, 371p; iron, 110belt, 100battery; 2x1-152/33(1), 2x1-149/26(1), 2x1-120/20(1), 6x1-120/32(2), 2-350TT(1)
	2	Formidabile	1862		
Regina Maria Pia	3	Regina Maria Pia	1864		4527(3-5)-4619(6)t, 81.2(3,4)-81.8(5,6)x15.2x6.4m, 6b,1hse(3,4)-8b,1hse(5,6), 2125-2924hp, 12.1-13.7kts, 484p; iron, 120(3,4)-110(5,6)belt, 110battery; 8x1-152/33, 5x1-120/24(3,4), 6x1-120/24(5,6), 4x1-57/40, 8x5-37/20(3-5), 2x5-37/20(6), 3-350TT(3,4,6)
	4	San Martino	1864		
	5	Castelfidardo	1864		
	6	Ancona	1866		
Affondatore	1	Affondatore	1866		4307t, 93.8x12.2x6.4m, 8b,1hse, 3240hp, 12kts, 356p; iron, 127belt, 51deck, 127turrets, 127CT; 2x1-254/30, 6x1-120/24, 1x1-75/21, 8x1-57/40, 4x5-37/20, 2-450TT
Principe Amedeo	1	Palestro	1875		6318t, 78.8ppx17.3x8.0m, 6b,1hse, 6117hp, 12.9kts, 548p; iron, 220belt, 140battery, 60CT; 1x1-279/13, 6x1-254/15
BB Duilio	9	Duilio	1880		12071(9)-11264(10)t, 109.2x19.7x8.3m, 8b,2vc, 7711(9)-8045(10)hp, 15(9)-15.6(10)kts, 420(9)-495(10)p; steel, 550belt, 50deck, 430(9)-225(10)turrets; 2x2-450/20(9), 2x2-254/40(10), 7x1-152/40(10), 3x1-120/40(9), 5x1-120/40(10), 16x1-57/43(10), 8x5-37/20(10), 4x1-11.4/94(10), 3-350TT(9), 4-450TT(10), 1TB(9)
	10	Dandolo	1882		
	11	Italia	1885		

Italia	2	12	Lepanto	1887		15047(11)-15649(12)t, 124.7x22.5(11)-22.3(12)x8.8(11)-9.4(12)m, 24b,4vc, 11986(11)-15797(12)hp, 17.8(11)-18.4(12)kts, 669p; 2x2-432/26-27(11), 2x2-432/27(12), 8x1-152/32(12), 7x1-149/26(11), 4x1-120/32, 2x1-76/40, 6x1-57/40(11), 12x1-57/40(12), 10x5-37/20(11), 12x5-37/20(12), 2x1-11.4/94(11), 6-350TT(11), 4-350TT(12); 10000men
		Ruggiero di Lauria	13	Ruggiero di Lauria	1888	
14	Francesco Morosini		1889			
15	Andrea Doria		1891			
Re Umberto	3	16	Re Umberto	1893		15454(16)-14842(17)-15426(18)t, 127.6(16)-130.7(17,18)x23.4x9.3(16)-8.8(17,18)m, 18b,2vc(16,17)-18b,2vte(18), 17000(16)-19131(17)-22800(18)hp, 18.2(16)-20(17,18)kts, 733-794p; steel, 100belt, 75deck, 100turrets, 300CT; 2x2-343/30, 8x1-152/40, 16x1-57/43(16), 20x1-57/43(17,18), 10x1-37/25, 5-450TT
		17	Sicilia	1895		
		18	Sardegna	1895		

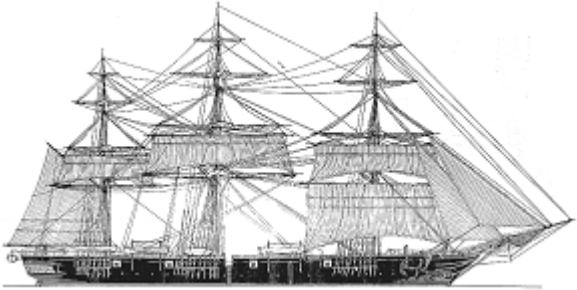
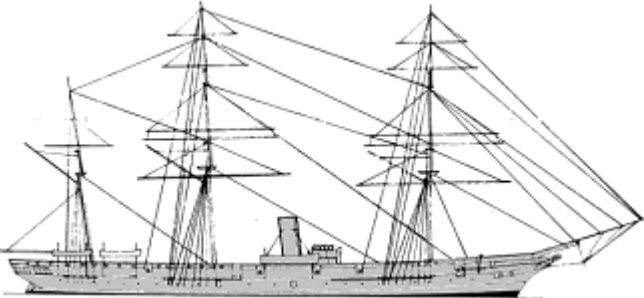
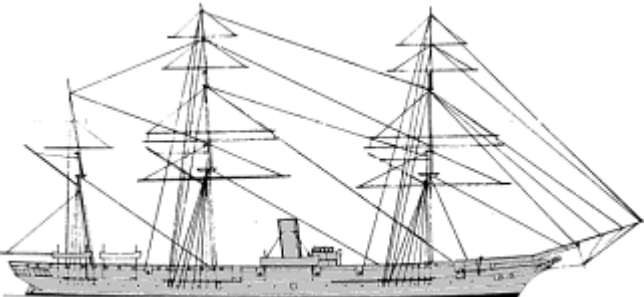
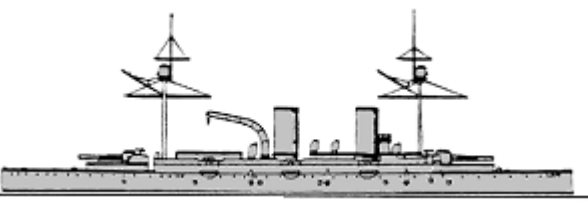
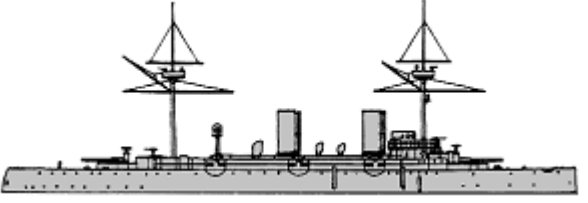
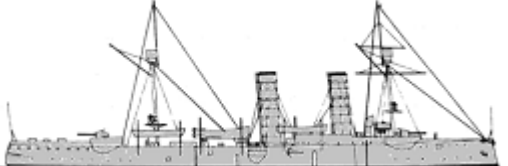
CRUISERS

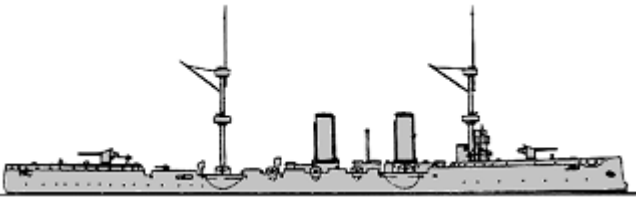
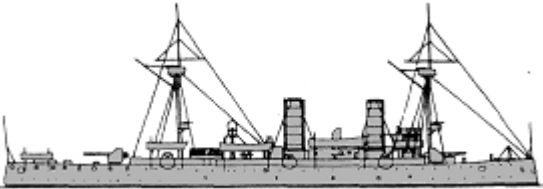
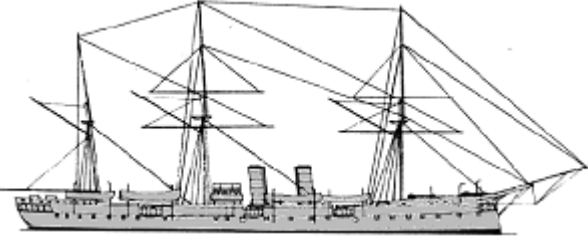
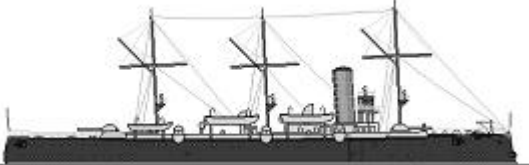

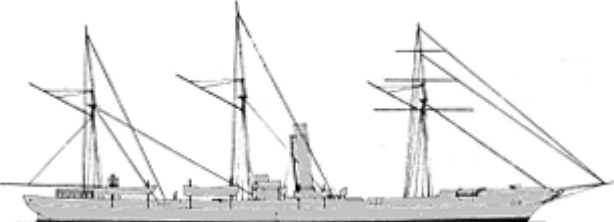
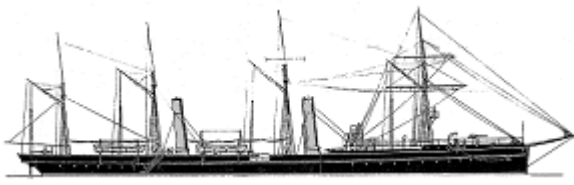

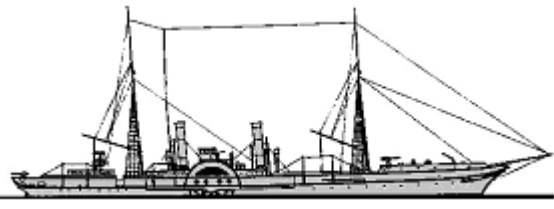
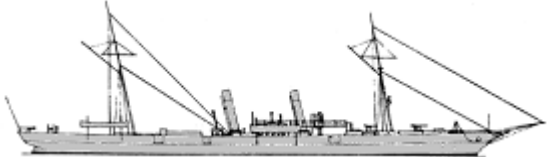

CA	Vittorio Emanuele	1	1	Vittorio Emanuele	1856	No picture	3300t, 61.9x15.3x6.3m, 3b,1hc, 1488hp, 9kts, 539p; 10x1-164/17, 2x1-120/40
	Maria Adelaide	1	2	Maria Adelaide	1860	No picture	3543t, 74.4ppx15.1x6.5m, 4b,1hc, 2255hp, 12kts, 578p; 1x1-229/14, 8x1-203/13, 4x1-164/17
	Marco Polo	1	3	Marco Polo	1894		4820t, 106.1x14.7x5.9m, 4b,2vte, 10663t, 17.8kts, 402p; 100belt, 25deck, 50shields, 50CT; 6x1-152/40, 10x1-120/40, 2x1-75/21, 9x1-57/40, 2x1-37/25, 2x1-11.4/94, 5-450TT
	Vettor Pisani	2	4	Carlo Alberto	1898		7057(4)-7128(5)t, 105.7x18.0x7.2m, 8b,2vte, 13219(4)-13259(5)hp, 19.1(4)-18.6(5)kts, 486p; Harvey, 150belt, 37deck, 150casemates, 150CT; 12x1-152/40, 6x1-120/40(4), 4x1-120/40(5), 2x1-75/21, 14x1-57/40, 6x1-37/25(4), 8x1-37/25(5), 2x1-11.4/94, 4-450TT
			5	Vettor Pisani	1899		



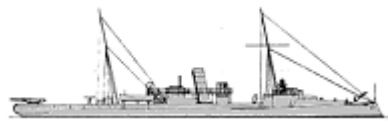
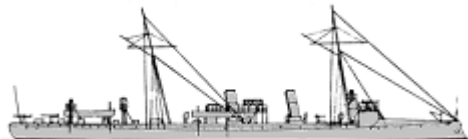
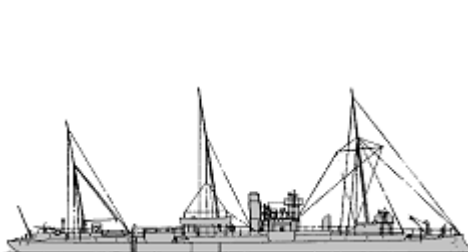







						1661t, 64.3ppx10.9x5.0m, sails, 247p; 2x1-75/21, 4x1-57/40
						3064t, 84.5x12.8x5.2m, 8b,1hr, 4156hp, 14kts, 268p; steel, deck; 4x1-120/40, 2-350TT
						2751t, 84.5x12.8x5.5m, 8b,1hr, 3000hp, 13kts, 268p; 4x1-120/40, 4x1-57/40, 2x1-37/20, 2-350TT
						3277t, 89.3x12.9x6.0m, 4b,2vde, 6470hp, 17.4kts, 295p; compound, 38deck, 13CT; 2x1-254/30, 6x1-152/40, 4x1-57/40, (6x5+3x1)-37/20, 2x1-11.4/94, 2-350TT
CL	Etna	5	Etna	1887		3737-3888t, 91.4x13.2x5.8m, 4b,2vde, 6252-7480hp, 16.6-18kts, 308p; compound, 38deck, 13CT; 2x1-254/30, 6x1-152/32(5-7), 6x1-152/40(8), 5x1-57/40(5-7), 6x1-57/40(8), (1x5+5x1)-37/20(5-7), 8x1-37/20(8), 2x1-11.4/94, 2-350TT(4-7), 3-350TT(8)
		6	Vesuvio	1888		
		7	Stromboli	1888		
		8	Ettore Fieramosca	1889		
						2050t, 76.2x11.3x4.4m, 4b,2vte, 5012hp, 17.7kts, 224p; compound, 51deck, 114shields, 51CT; 6x1-152/32, 9x1-57/40, 6x5-11.4/94, 4-350TT
						2597t, 97.8x11.6x4.9m, 4b,2vte, 7100hp, 20.4kts, 298p; compound, 76deck, 114shields, 76CT; 2x1-152/40, 10x1-120/40, 10x1-57/40, 6x1-37/20, 4x1-11.4/94, 2-350TT

													
Umbria	5	11	Umbria	1894		2411-2750(11-14)-2950(15)t, 84.8(11-14)-88.2(15)x12.0(11-14)-12.7(15)x4.7-5.5m, 4b,2hte, 6842-7677hp, 17-19.8kts, 213-278p; Harvey, 50deck, 50CT; 4x1-152/40, 6x1-120/40, 1x1-75/21(11), 7x1-57/40(11), 10x1-57/40(12), 8x1-57/40(13-15), 9x1-37/25(11), 2x1-37/25(13,14), 6x1-37/25(15), 2-450TT							
		12	Lombardia	1893									
		13	Etruria	1894									
		14	Liguria	1894									
		15	Elba	1896									
Cristoforo Colombo	1	16	Cristoforo Colombo	1894		2713t, 76.4ppx11.3x5.7m, 6b,1hc, 2321hp, 13kts, 238p; 8x1-120/40, 2x1-75/21							
Calabria	1	17	Calabria	1897		2660t, 81.0x12.7x5.1m, 4b,2vte, 4260hp, 16.4kts, 254p; 50deck, 50CT; 4x1-152/40, 6x1-120/40, 8x1-57/40, 8x1-37/25, 2-450TT							
SL						814t, 56.3x8.2x3.6m, 2b,1hse, 670hp, 11kts, 95p; 2x1-37/25, 2x5-37/20							
							Vedetta	1	1	Vedetta	1869		
							Staffetta	1	2	Staffetta	1877		1777t, 85.6x9.4x4.0m, 2b,1hde, 1700hp, 12.5kts, 144p; 4x1-120/20, 4x1-57/43, 1-350TT
							Rapido	1	3	Rapido	1877		1523t, 81.1x9.3x3.8m, 4b,1vde, 1920hp, 13.5kts, 144p; 5x1-57/43, 2x1-11.4/94
							Agostino Barbarigo	2	4	Agostino Barbarigo	1879		805(4)-770(5)t, 68.1x7.4x3.4m, 4b,1vte, 1704-1760hp, 15kts, 104p; 5x1-57/43, 2x1-25/41
		5	Marcantonio Colonna	1880									

Messaggero	1	6	Messaggero	1888		1137t, 72.0ppx9.1x3.2m, 4b,1hse(sw), 1797hp, 14kts, 107p; 4x1-57/43, 4x5-37/20
Archimede	2	7	Galileo Galilei	1888		886(7)-950(8)t, 77.0x8.0x3.8m, 4b,1vte, 1384-1411hp, 12kts, 73p; 4x1-120/24, 2x1-57/43, 2x5-37/20
		8	Archimede	1888		

TORPEDO SHIPS

PGT	Tripoli	1	1	Tripoli	1886		952t, 73.4x7.9x3.7m, 6b,3de, 2500hp, 17.5kts, 111p; steel, 40deck; 1x1-120/32, 6x1-57/43, (3x5+2x1)-37/20, 5-350TT
	Folgore	2	2	Folgore	1887		364-394t, 56.7x6.3x2.2m, 4b,2vde, 2150hp, 17kts, 70p; 1x1-76/40(3), 2x1-57/43, 2x1-57/40(3), 2x1-47/40(3), 4x1-37/25(2), 1x5-37/20(3), 3x1-350TT(2)
			3	Saetta	1888		
	Goito	4	4	Monzambano	1889		955-974t, 73.4x7.9-8.0x3.0-3.6m, 4b,3vde(4)-6b,2vde(5)-6b,3vte(6)-4b,2vde(7), 2500(5)-3180(4,6)-1962(7)hp, 18(4,6)-17(5,7)kts, 121p; steel, 40deck; 1x1-120/32(7), 6x1-57/40(4,6,7), 5x1-57/40(5), (3x5+2x1)-37/20(5), 2x1-37/20(6,7), 5-350TT(4,7), 4-350TT(6), 60mines(5)
			5	Goito	1888		
			6	Montebello	1889		
			7	Confianza	1890		
	Partenope	8	8	Partenope	1890		821-931t, 73.1x8.2x3.5m, 4b,2vte, 3884-4422hp, 18.1-20.8kts, 121p; 1x1-120/40(8-13,15), 2x1-120/40(14), 6x1-57/43(8-13,15), 4x1-57/43(14), 3x1-37/20(8-13,15), 2x1-37/20(14), (1+4x1)-450TT(8), (2+4x1)-450TT(9-15)
			9	Minerva	1892		
			10	Euridice	1891		
			11	Urania	1893		
			12	Iride	1892		
			13	Aretusa	1892		
			14	Caprera	1895		
			15	Calatafimi	1894		
Nibbio	1	1	1T	1881	No picture	26t, 24.4x3.1x1.1m, 1b,1ter, 250hp, 18kts, 10p; 2-350TT	
Avvoltoio	1	2	2Y	1881		25t, 26.2x3.3x1.0m, 1b,1vte, 420hp, 21.3kts, 10p; 2-350TT	
Sparviero	2	3, 4	22Y, 25Y	1881		40t, 30.4x3.8x1.5m, 1b,1vr, 620hp, 22.5kts, 11p; 1x2-25/41, 2-350TT	
Aquila	2	5, 6	23T, 24T	1882		35t, 29.2x3.3x1.5m, 1b,1vde, 475hp, 20kts, 11p; 1x2-25/41, 2-350TT	
Aldebaran	11	7-17	26T-35T, 40T	1882-1885		39t, 30.6x3.6x1.7m, 1b,1vde, 430-455hp, 21kts, 11p; 1x2-25/41, 2-350TT	
Euterpe	1	18	18T	1883	No picture	14t, 19.2x2.3x1.1m, 1b,1vte, 170hp, 17.3kts, 10p; 1x5-25/41, 2-350TT	
Arturo	5	19-23	38T, 46T, 47T, 50T, 51T	1885-1887		39t, 30.6x3.6x1.7m, 1b,1vde, 430-455hp, 21kts, 11p; 1x2-25/41, 2-350TT	
Vega	6	24-29	36T, 41T, 44T, 45T, 52T, 53T	1885-1888		39t, 30.6x3.6x1.7m, 1b,1vde, 430hp, 21kts, 11p; 1x2-25/41, 2-350TT	







TB	Procione	6	30-35	37T, 39T, 48T, 49T, 54T, 55T	1885-1887		39t, 30.6x3.6x1.7m, 1b,1vde, 390-430hp, 21kts, 11p; 1x2-25/41, 2-350TT
	Clio	1	36	11T	1885	No picture	31t, 23.4x3.0x1.5m, 1b,1ter, 250hp, 18kts, 10p; 2-350TT
	Acquario	2	37, 38	42T, 43T	1885		39t, 30.6x3.6x1.7m, 1b,1vde, 387-430hp, 21kts, 11p; 1x2-25/41, 2-350TT
	56S	17	39-55	81S-85S, 99S-104S, 106S-111S	1886-1887		78t, 39.8x4.8x2.0m, 1b,1vde, 902-1080hp, 21-22kts, 17p; 2x1-37/20, 2-350TT(39-50), (1+1x1)-350TT(51-55)
	76Ya	4	56	76Ya	1887		108t, 41.2x4.3x1.5m, 2b,2vde, 1600-1640hp, 26(56,57)-22(58,59)kts, 20p; 2x5-37/20, (2+1x2)-350TT(56,57), (2+1x1)-350TT(58,59)
			57	77Ya	1887		
			58	78Ya	1895		
			59	79Ya	1896		
	72S	34	60-93	72S-75S, 93S-98S, 105S, 112S-123S, 128S-131S, 136S-138S, 147S-150S	1887-1895		78t, 39.8x4.8x2.0m, 1b,1vde(60-62,64-66,68-93)-2b,1vde(63,67), 902-1080hp, 21-22kts, 17p; 2x1-37/20(60-69), 2x1-37/25(70-93), 2-350TT(60-69), (1+1x1)-350TT(70-93)
	68S	11	94-104	68S-71S, 116S-119S, 146S, 153S, 154S	1887-1894		78t, 39.8x4.8x2.0m, 1b,1vde, 723-1946hp, 21-22kts, 17p; 2x1-37/20(94-97), 2x1-37/25(98-104), 2-350TT(94-97), (1+1x1)-350TT(98-104)
	66S	2	105, 106	66S, 67S	1888		78t, 39.8x4.8x2.0m, 1b,1vde, 902-1080hp, 21-22kts, 17p; 2x1-37/20, 2-350TT
60S	16	107-122	60S-65S, 112S-115S, 132S-135S, 151S, 152S	1888-1894		78t, 39.8x4.8x2.0m, 1b,1vde(107-118,120-122)-2b,1vde(119), 683-1082hp, 21-22kts, 17p; 2x1-37/20(107-112), 2x1-37/25(113-122), 2-350TT(107-112), (1+1x1)-350TT(113-122)	
56S	18	123-140	80S, 86S-92S, 124S-127S, 139S-144S	1888-1893		78t, 39.8x4.8x2.0m, 1b,1vde, 782-1079hp, 21-22kts, 17p; 2x1-37/20(123-130), 2x1-37/25(131-140), 2-350TT(123-130), (1+1x1)-350TT(131-140)	
Aquila	5	141	Aquila	1888		137t, 47.6x5.1x2.2m, 2b,2vde, 2180hp, 24kts, 24p; 2x1-37/25, (1+2x1)-350TT	
		142	Sparviero	1888			
		143	Falco	1888			
		144	Nibbio	1888			
		145	Avvoltoio	1888			

SUBMARINES

SS	Delfino	1	1	Delfino	1895		95/107t, 24.0x2.9x2.6m, 1em, 65hp, 6/5kts, 8p, 30m; 2-350TT
----	---------	---	---	---------	------	---	---

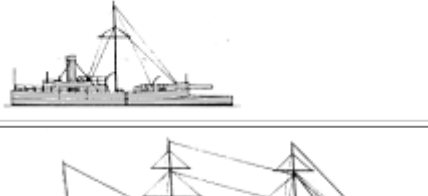
OTHER FIGHTING SHIPS

Guardiano	1	1	Sentinella	1874	No picture	261t, 30.5x8.3x2.0m, 1b,2hc, 260hp, 9.1kts, 48p; 1x1-229/14
Scilla	2	2	Scilla	1876		1059(2)-1084(3)t, 57.7wlx8.7x4.3m, 2b,1hte, 826-956hp, 10.5kts, 139p; 1x1-164/16, 3x1-120/20(2), 2x1-120/20(3), 2x1-57/43(2), 2x1-37/20(2)
		3	Cariddi	1876		

PG	Andrea Provana	2	4	Andrea Provana	1885		632(4)-618(5)t, 51.5x8.0x3.4m, 2b,1vte, 1087(4)-1160(5)hp, 13.6(4)-13.4(5)kts, 107p; 4x1-120/20, 4x1-25/41
			5	Sebastiano Veniero	1885		
	Curtatone	2	6	Voltorno	1889		1155(6)-1039(7)t, 54.1ppx9.9x4.5m, 3b,1vc, 1110(6)-1043(7)hp, 11.4(6)-10.7(7)kts, 144p; 4x1-120/32, 4x1-57/43, 2x1-37/20, 2x1-11.4/94, 1-350TT
			7	Curtatone	1890		
	Castore	1	8	Polluce	1891		522t, 35.1x11.3x2.5m, 2b,1vc, 364hp, 8kts, 49p; 1x1-120/40, 1x1-11.4/94
	Governolo	1	9	Governolo	1896		1203t, 56.4ppx10.3x4.6m, 3b,1vc, 1100hp, 14kts, 137p; 4x1-120/32, 4x1-57/43, 2x1-37/25, 2x1-11.4/94, 1-450TT

MINE WARFARE SHIPS

AML	-	1	1	Betta N.3	1891	580t; mines
-----	---	---	---	-----------	------	-------------

[home](#)[World navies yesterday](#)[1900](#)

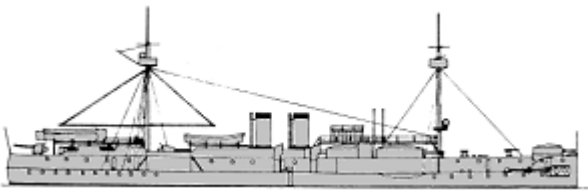
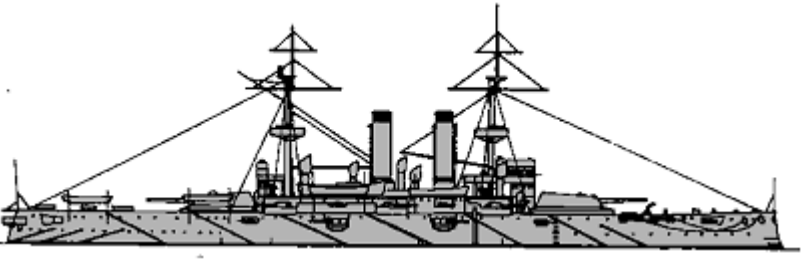
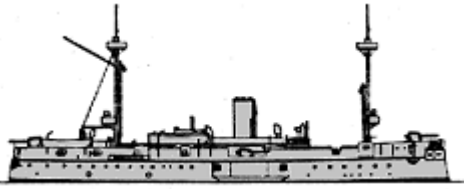
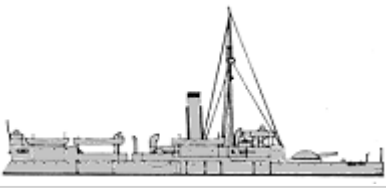

Japan 01 January 1900

BATTLESHIPS

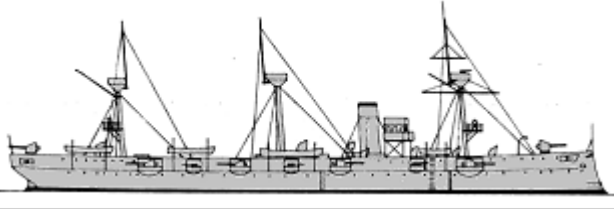

	Chin Yen	1	1	Chin Yen	1885		7670t, 93.9x18.0x6.1m, 8b,2hc, 6300hp, 14.5kts, 329p; steel-356belt, 76deck, 305turrets, 203CT; 2x2-305/22, 4x1-152/40, 2x1-57/43, 8x1-47/40, 3-350TT, 2tb
BB			2	Fuji	1897		12533(2)-12320(3)t, 125.5x22.2(2)-22.4(3)x8.1(2)-8.0(3)m, 10b,2vte(2)-14b,2vte(3), 14000hp, 18kts, 741p; Harvey- 457belt, 63deck, 152turrets, 356CT; 2x2-305/40, 10x1-152/40, 20x1-47/40, 4x1-47/30, 5-450TT
	Fuji	2	3	Yashima	1897		
BC	Fuso	1	1	Fuso	1878		3717t, 68.9x14.6x5.5m, 8b,2htc, 3500hp, 13kts, 250p; iron- 229belt, 229battery; 4x1-235/20, 4x1-120/40, 12x1-47/40, 4x4-25/60, 2-350TT
	Hei Yen	1	2	Hei Yen	1889		2640t, 70.2x12.2x4.2m, 4b,2vte, 2400hp, 10.2kts, 204p; iron- 203belt, 50deck, 125barbette, 125CT; 1x1-263/32, 2x1-149/32, 4x1-47/40, 2x10-11.4/94, 2-350TT

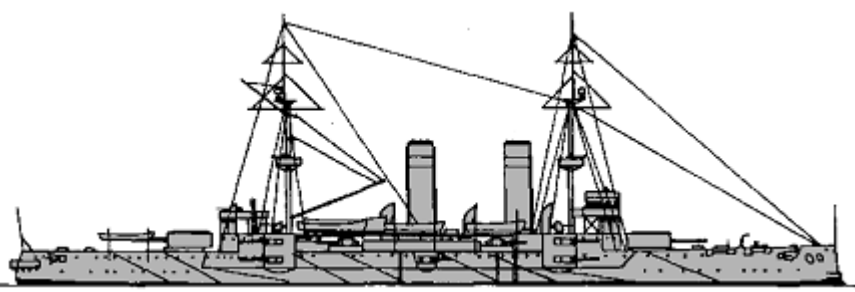
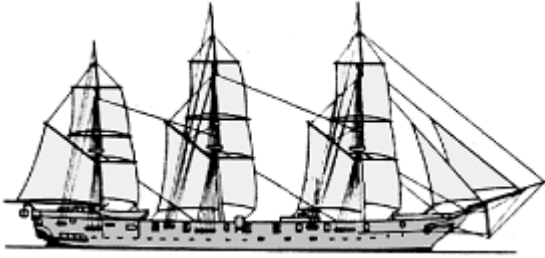
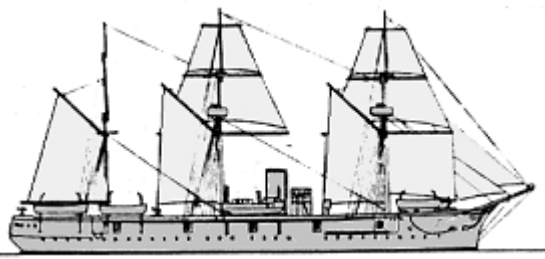
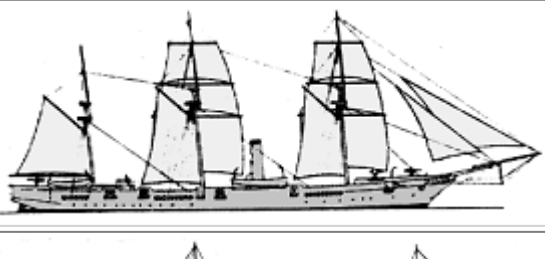
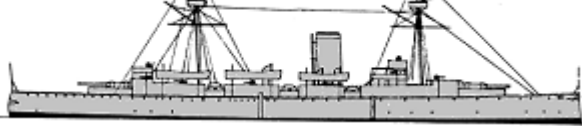
CRUISERS

	Chiyoda	1	1	Chiyoda	1891		2439t, 94.5x12.8x4.3m, 12b,2vte, 5600hp, 19kts, 350p; compound- 92belt, 35deck, 30CT; 10x1-120/40, 14x1-47/40, 3x10-11.4/94, 3-350TT
CA			2	Asama	1899		

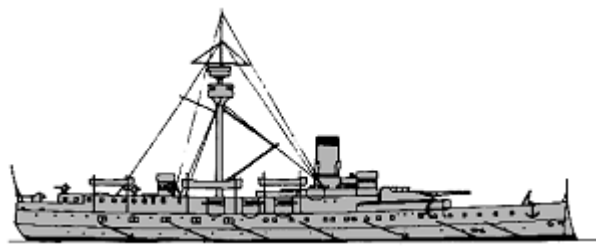
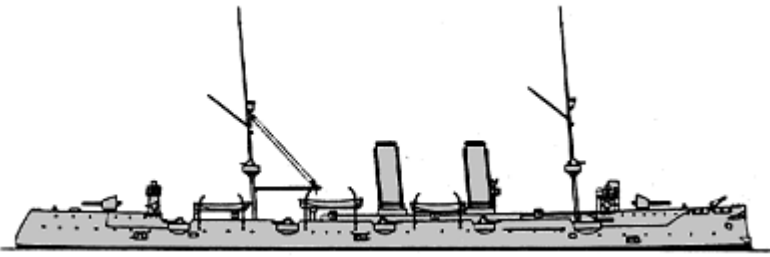
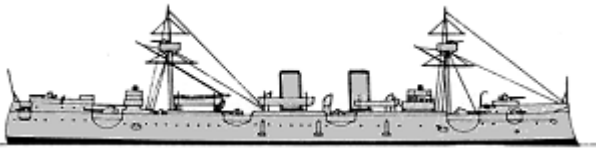
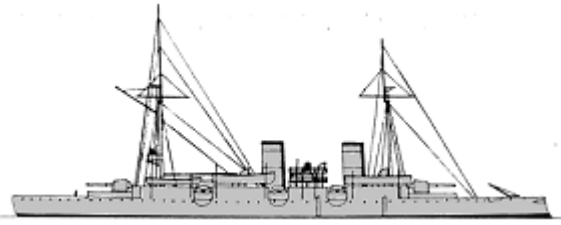
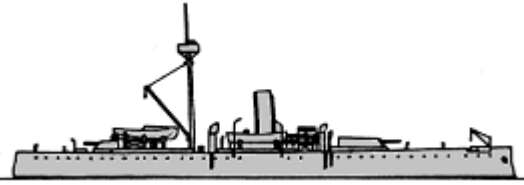
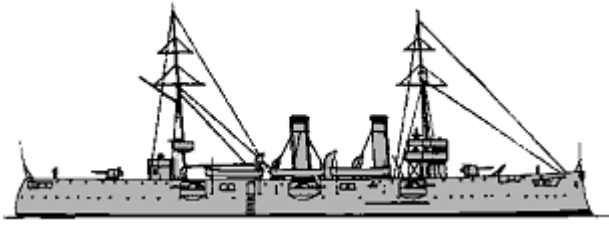
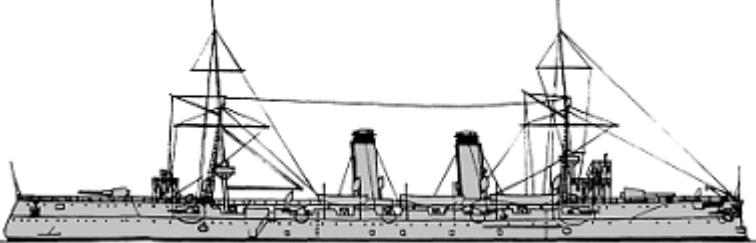

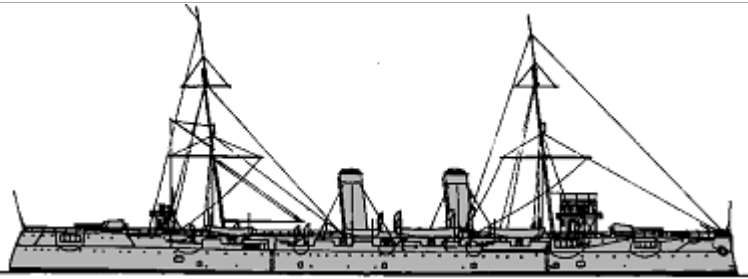
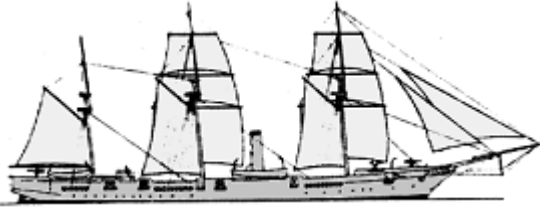

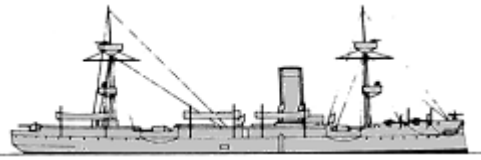
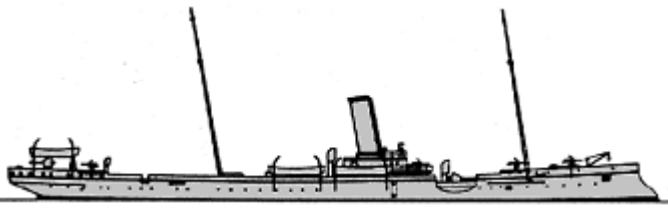
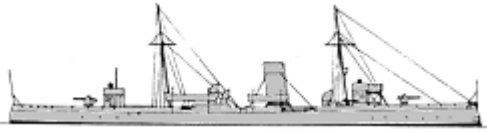
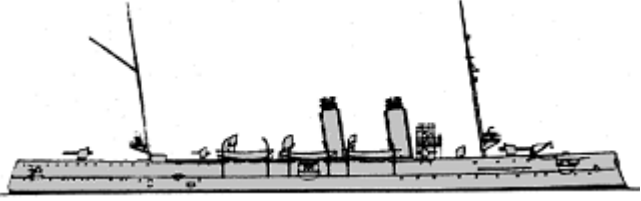

Asama	2	3	Tokiwa	1899		10500t, 134.7x20.5x7.4m, 12b,2vte, 18000hp, 21.5kts, 726p; Harvey- 178belt, 76deck, 152turrets, 356CT; 2x2-203/45, 14x1-152/40, 12x1-76/40, 7x1-47/30, 5-450TT
Tsukuba	1	1	Tsukuba	1854		1978bm, 60.3x10.6x5.5m, 2b,1hse, 707hp, 9.5kts, 301p; 4x1-152/40
Kongo	2	2	Kongo	1878		3718t, 70.5x12.5x5.5m, 6b,1hc(2)-2b,1hc(3), 2490hp, 14kts, 314p; compound- 114belt; 3x1-173/17, 6x1-149/22, 2x1-75/11, 2x1-47/40, 4x4-25/60, 2x5-11.4/94, 2-350TT
		3	Hiei	1878		
Kaimon	2	4	Kaimon	1884		1429(4)-1525(5)t, 64.1(4)-64.7(5)x9.9(4)-10.8(5)x5.0(4)-5.2(5)m, 4b,1hcra, 1267hp, 12kts, 214p; 1x1-173/22, 1x1-149/22(5), 6x1-120/22(4), 4x1-120/22(5), 1x1-79/25, 4x4-25/60, 1x4-11.4/94(4)
		5	Tenryu	1885		
Naniwa	2	6	Naniwa	1885		3708t, 97.5x14.0x6.1m, 6b,2hc, 7000hp, 18.5kts, 325p; steel- 76deck, 51barbettes, 38CT; 2x1-263/32, 6x1-152/40, 6x1-47/40, 4-350TT
		7	Takachiho	1886		
Katsuragi	3	8	Katsuragi	1887		1502t, 62.8x10.7x4.6m, 6b,1hcra, 1622hp, 13kts, 231p; 2x1-173/22, 5x1-120/22, 1x1-79/25, 4x4-25/60, 2-380TT
		9	Yamato	1888		
		10	Musashi	1887		
Itsukushima	3	11	Itsukushima	1891		4217t, 99.8x15.4x6.0m, 6b,2hte, 5400hp, 16.5kts, 360p; Harvey- 40deck, 100turret, 125CT; 1x1-320/38, 11x1-120/40(11,13), 12x1-120/40(12), 5x1-57/40(11), 6x1-57/40(12,13), 12x1-37/20(11), 11x1-37/20(12,13), 4-350TT
		12	Matsushima	1892		
		13	Hashidate	1894		

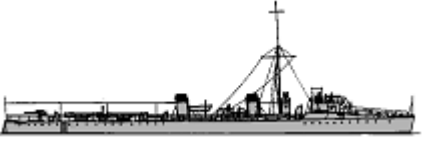
						
CL	Yoshino	1 14	Yoshino	1893		4150t, 118.3x14.2x5.2m, 12b,2vte, 15750hp, 22.5kts, 385p; Harvey- 114slopes, 45deck, 114shields, 76CT; 4x1-152/40, 8x1-120/40, 22x1-47/40, 5-350TT
	Akitsushima	1 15	Akitsushima	1894		3150t, 92.0x13.1x5.3m, 6b,2vte, 8400hp, 19kts, 314p; Harvey- 76deck, 114shields; 4x1-152/40, 6x1-120/40, 8x1-47/40, 4-350TT
	Idzumi	1 16	Idzumi	1884		2920t, 82.3ppx12.8x5.6m, 12b,2hc, 6083hp, 18.2kts, 300p; compound- 25slopes, 13deck; 2x1-254/30, 6x1-120/40, 2x1-57/40, 6x1-47/40, 3-350TT
	Sai Yen	1 17	Sai Yen	1885		2440t, 75.0x10.4x5.2m, 2b,2vc, 2800hp, 15kts, 202p; compound- 75deck, 250barbettes, 38CT; 1x2-209/27, 1x1-149/32, 8x1-47/40, 4-350TT, 2tb
	Suma	18	Suma	1896		2657(18)-2756(19)t, 95.0(18)-93.3(19)x12.2(18)-12.7(19)x4.6(18)-4.8(19)m, 8b,2vte(18)-9b,2vte(19), 8500hp, 20kts, 310p; Harvey- 51slopes, 25deck, 114shields; 2x1-152/40, 6x1-120/40, 10x1-47/40, 4x1-47/30, 2-380TT
		19	Akashi	1899		
	Takasago	1 20	Takasago	1898		4160t, 118.2x14.8x5.2m, 8b,2vte, 15500hp, 23.5kts, 425p; Harvey- 114slopes, 63deck, 114shields, 114CT; 2x1-203/45, 10x1-120/40, 12x1-76/40, 6x1-47/30, 5-450TT
		21	Chitose	1899		

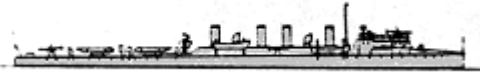
	Chitose	2	22	Kasagi	1898		5598(21)-6066(22)t, 120.4(21)-121.5(22)x15.0(21)-14.9(22)x5.4m, 12b,2vte, 15000hp, 22.5kts, 434(21)-405(22)p; Harvey- 114slopes, 45deck, 114shields, 114CT; 2x1-203/45, 10x1-120/40, 12x1-76/40, 6x1-47/30, 5-350TT
CLL	Amagi	1	1	Amagi	1878		1030t, 65.3x10.1x4.4m, 2b,1hc, 720hp, 11.5kts, 301p; 1x1-173/22, 4x1-120/22, 1x1-120/17, 3x1-79/25, 3x4-25/60
	Tsukushi	1	2	Tsukushi	1880		1542t, 64.0ppx9.7x4.4m, 4b,2hc, 2887hp, 16.5kts, 186p; steel- 10deck, 25casemates, 13CT; 2x1-254/26, 4x1-120/32, 1x1-76/40, 2x1-47/40, 2-350TT
	Takao	1	3	Takao	1889		1927t, 71.1x10.4x4.0m, 5b,2hc, 2330hp, 15kts, 229p; 4x1-149/32, 1x1-120/22, 1x1-79/25, 6x4-25/60, 2x2-25/60, 2-350TT
	Yaeyama	1	4	Yaeyama	1892		1609t, 96.9ppx10.5x4.0m, 6b,2hte, 5400hp, 20kts, 215p; steel- 13deck; 3x1-120/32, 10x1-47/40, 2-350TT
	Tatsuta	1	5	Tatsuta	1894		850t, 73.1ppx8.4x2.9m, 4b,2vte, 5500hp, 21kts, 100p; 2x1-120/40, 4x1-47/40, 5x1-47/30, (1+2x2)-350TT
	Miyako	1	6	Miyako	1899		1772t, 96.0ppx10.5x4.3m, 8b,2vte, 6130hp, 20kts, 200p; 2x1-120/40, 8x1-47/40, 2-450TT

TORPEDO SHIPS

	Murakumo	5	1	Kagero	1899		361t, 65.7x6.0x1.7m, 3b,2vte, 5800hp, 30kts, 54p; 1x1-76/40, 5x1-57/40, 2x1-450TT
			2	Murakumo	1898		
			3	Shinonome	1899		
			4	Shiranui	1899		

DD	Ikazuchi	6	5	Yugiri	1899		410t, 68.5x6.3x1.6m, 4b,2vte, 6000hp, 31kts, 55p; 1x1-76/40, 5x1-57/40, 2x1-450TT
			6	Ikazuchi	1899		
			7	Inazuma	1899		
			8	Niji	1899		
			9	Akebono	1899		
			10	Oboro	1899		
			11	Sazanami	1899		
TB1	Kotaka	1	1	Kotaka	1888		203t, 50.3ppx5.8x1.7m, 2b,2vc, 1200hp, 17.8kts, 27p; steel- 25belt, 25deck; 2x4-25/60, (2+1x2)-350TT
	Fukuryu	1	2	Fukuryu	1886		128t, 43.9x5.0x2.3m, 1b,1vc, 1015hp, 20kts, 27p; 2x5-37/20, 2-350TT
TB2	22-go	1	1	25-go	1895		85t, 39.0ppx4.8x1.1m, 1b,1vte, 990hp, 19kts, 20p; 2x1-47/30, 3x1-350TT
	21-go	2	2, 3	21-go, 24-go	1894 - 1895		80t, 36.0ppx4.0x1.2m, 1b,1vte, 1150hp, 21kts, 21p; 1x1-47/30, 3x1-350TT
TB3	5-go	14	1 - 14	5-go-14-go, 16-go-19-go	1892 - 1894		54t, 35.0x3.4x0.9m, 1b,1hc, 525hp, 20kts, 16p; 1x1-47/30, (1+1x1)-350TT
	15-go	2	15, 16	15-go, 20-go	1893 - 1894		54t, 35.0x3.5x1.0m, 1b,1vte, 657hp, 20kts, 20p; 1x1-47/30, 1x2-350TT
	26-go	2	17, 18	26-go, 27-go	1887	No picture	74t, 33.7x3.5x1.1m, 1b,1hc, 338(17)-442(18)hp, 13.8(17)-15.5(18)kts, 28p; 2x5-37/20, 2-350TT
	28-go	1	19	28-go	1885	No picture	16t, 19.7x2.6x1.1m, 1b,1hc, 91hp, 10.6kts, 7p; 1x1-37/20, 2-350TT

OTHER FIGHTING SHIPS

PG	Banjo	1	1	Banjo	1880	No picture	708t, 46.9x7.9x3.9m, 4b,1hc, 659hp, 10kts, 112p; 1x1-149/22, 1x1-120/22, 2x1-79/25, 3x4-25/60
	Maya	4	2	Maya	1888		622t, 46.8ppx8.2x3.1m, 2b,2hcda, 963hp, 12kts, 104p; 1x1-209/19(3,4), 4x1-120/40(2,5), 1x1-120/22(3,4), 2x1-57/43(2), 2x1-47/40(2), 4x1-47/40(5), 2x4-25/60
			3	Chokai	1888		
			4	Atago	1889		
			5	Akagi	1890		
	Oshima	1	6	Oshima	1892		640t, 53.7ppx8.0x2.8m, 2b,2vte, 1200hp, 13kts, 130p; steel- 30deck; 4x1-120/40, 5x1-47/40, 1x5-11.4/94
	Soko	1	7	Soko	1869		950t, 54.9x8.6x3.3m, 1b,1hse, 425hp, 9kts, 79p; 2x1-76/40
			8	Chinto	1879		
			9	Chinsei	1879		

Chinto	4					490t, 38.1ppx8.8x2.9m, 2b,2hc, 450hp, 10kts, 28p; 1x1-279/23, 2x1-76/19, 2x10-11.4/94
		10	Chinnan	1879		
Chinchu	2	11	Chimpen	1879		500t, 38.1ppx8.8x2.9m, 2b,2hc, 450hp, 10kts, 28p; 1x1-279/23, 2x1-102/25, 2x10-11.4/94
		12	Chinchu	1881		
		13	Chimpen	1881		



© Ivan Gogin, 2014



[home](#)[World navies yesterday](#)[1900](#)

Mexico 01 January 1900

CRUISERS

CL	Porfirio Díaz	1	1	Porfirio Díaz	1892		1200t, 68.0x9.3x4.3m, 2b,1vte, 1300hp, 15kts, 270p; 4x1-120/40, 2x1-57/40
----	---------------	---	---	---------------	------	--	---

OTHER FIGHTING SHIPS

PG	Independencia	2	1	Independencia	1874		480t, 38.1x7.3x2.7m, 1hc, 425hp, 10kts, 63p; 1x1-163/16, 4x1-95/21
			2	Libertad	1874		
	Democrata	2	3	Democrata	1875		
			4	Mexico	1875		

© Ivan Gogin, 2015

[home](#)[World navies yesterday](#)[1900](#)

Morocco 01 January 1900

CRUISERS

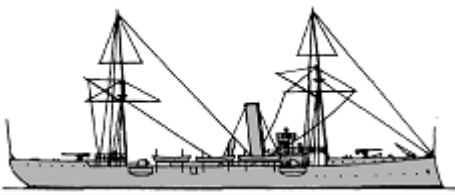
CLL	El Bashir	1	1	El Bashir	1892		1200t, 70.0x10.0x2.6m, 1vte, 2500hp, 18kts, 150p; 2x1-120/40, 4x1-37/25, 4-356TT
-----	-----------	---	---	-----------	------	--	--

OTHER FIGHTING SHIPS







PG	Es Sid El Turki	1	1	Es Sid El Turki	1894	No picture	460brt, 1200hp, 14.5kts; 2x1-76/18
	El Hassaneh	1	2	El Hassaneh	1884	No picture	1164t; 1x1-173/22

© Ivan Gogin, 2015

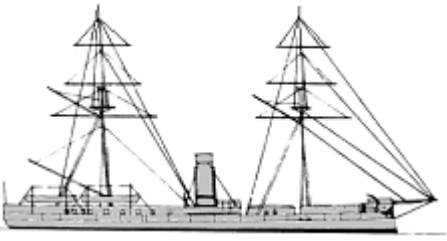
[home](#)[World navies yesterday](#)[1900](#)

Netherlands 01 January 1900

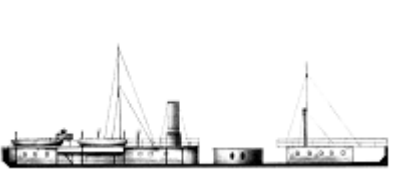
BATTLESHIPS

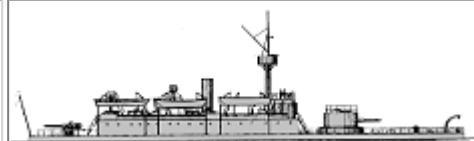

BC	Schorpionen	1	Schorpionen	1868		2140(1)-2078(2)t, 62.5x11.9x4.8(1)-5.1(2)m, 4b,2hrccr, 2225(1)-2260(2)hp, 13(1)-12.5(2)kts, 136p; iron- 152side, 25deck, 278turret, 144CT; 1x1-283/20, 5x1-37/20, 2x5-37/17
		2	Stier	1868		
	Evertsen	3	Evertsen	1896		3464t, 86.2x14.3x5.2m, 6b,2vte, 4700hp, 16kts, 263p; steel- 150belt, 55deck, 240barbette, 240CT; (1x2+1x1)-209/32, 2x1-149/32, 6x1-75/27, 8x1-37/20, 3-450TT
4	Piet Hein	1896				
5	Kortenaer	1895				
MON	Heiligerlee	1	Heiligerlee	1868		1520t, 57.0x13.5x3.1m, 4b,2hrccr, 630hp, 9kts, 117p; iron- 140side, 25deck, 285turret, 140CT; 1x1-283/20, 2x1-37/20, 2x5-37/17
		2	Krokodil	1868		
	Bloedhond	3	Bloedhond	1870		1656(3)-1559(4)t, 55.7(3)-56.5(4)x14.2(3)-13.4(4)x3.2(3)-3.0(4)m, 4b,2hrccr, 680(3)-534(4)hp, 7.7(3)-7(4)kts, 117p; iron- 140side, 25deck, 285turret, 140CT; 1x1-283/20, 2x1-37/20, 2x5-37/17
		4	Cerberus	1870		
	Adder	5	Haai	1872		1555(5,6,8,9)-1585(7)t, 58.6-59.6x13.4x3.0m, 4b,2hc, 560-740hp, 7-8kts, 117p; iron- 140side, 25deck, 285turrets, 140CT; 1x1-283/20, 2x1-37/20, 2x5-37/17
		6	Hyena	1871		
		7	Luipaard	1878		
		8	Panther	1871		
		9	Wesp	1872		
	Draak	1	10	Draak	1878	
Matador	1	11	Matador	1879		1968t, 63.9x14.5x3.2m, 4b,2hc, 690hp, 7.5kts, 131p; iron- 140side, 25deck, 305turret, 140CT; 1x2-283/20, 2x1-37/20, 2x5-37/17
Reinier Claeszen	1	12	Reinier Claeszen	1894		2440t, 70.0x13.5x4.6m, 3b,2vc, 2315hp, 12.5kts, 161p; compound- 120belt, 75deck, 280turret, 280CT; 1x1-209/32, 1x1-173/32, 4x1-50/37, 2-356TT



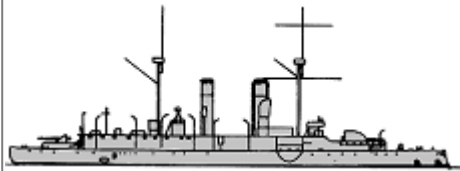
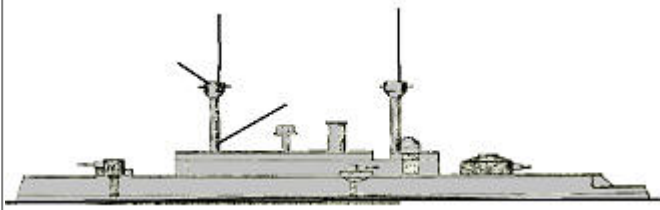
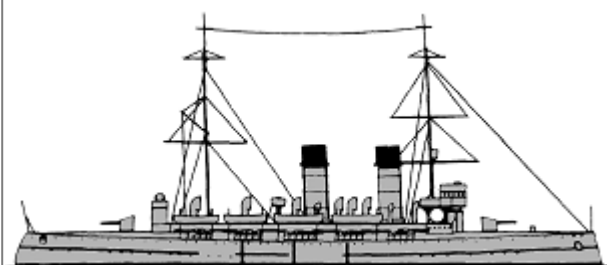
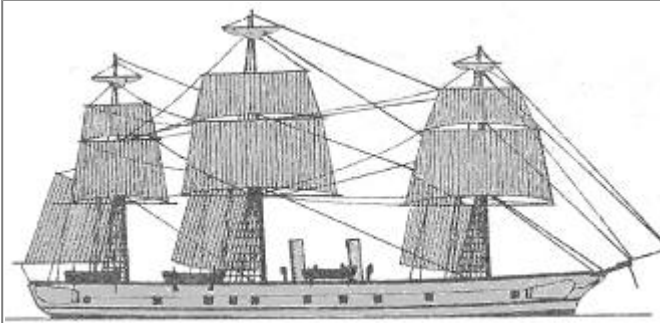









CRUISERS

CL	Sumatra	1	1	Sumatra	1891		1693t, 70.0x11.3x4.7m, 4b,2vte, 2350hp, 17kts, 181p; steel- 38deck, 100shields, 150CT; 1x1-209/32, 1x1-149/32, 2x1-120/32, 4x1-37/20, 2x5-37/17, 2-356TT
	Koningin Wilhelmina der Nederlanden	1	2	Koningin Wilhelmina der Nederlanden	1894		4530t, 99.8x14.9x6.1m, 6b,2vte, 4600hp, 15.8kts, 296p; compound- 75slopes, 50deck, 280turret; 1x1-283/27, 1x1-209/32, 2x1-173/32, 4x1-75/37, 6x1-37/20, 4x5-37/17, 4-356TT
	Holland	3	5	Holland Zeeland Friesland	1898 1898 1898		3840t, 93.3x14.8x5.4m, 8b,2vte, 10000hp, 20kts, 371p; Harvey- 57deck, 152shields, 102CT; 2x1-149/37, 6x1-120/37, 6x1-75/37, 8x1-37/20, 4x5-37/17, 2-450TT
CLL	Alkmaar	1	1	Alkmaar	1874	No picture	1051t, 54.5x9.2x4.8m, 686hp, 10.3kts, 106p; 1x1-149/22, 6x1-120/16, 2x1-37/20, 2x5-37/17
	Atjeh	3	2	Atjeh	1877		3425-3669t, 91.8-92.1x12.5x6.4-7.0m, 2700-3300hp, 13.5-14.8kts, 277-306p; 6x1-173/22, 8x1-120/16, 8x1-37/20, 6x5-37/17
			3	Tromp	1878		
			4	Koningin Emma der Nederlanden	1880		
Sommelsdijk	1	5	Sommelsdijk	1882	No picture	997t, 54.5x9.5x3.6m, 759hp, 11.4kts, 96p; 1x1-149/22, 3x1-120/16, 2x1-37/20, 2x5-37/17	
Java	1	6	Java	1885	No picture	1280t, 62.6x9.5x3.7m, 1017hp, 12.6kts, 104p; 1x1-149/22, 3x1-120/16, 2x1-37/20	

TORPEDO SHIPS

TB1cl	Ardjoeno	10	1-10	Ardjoeno, Dempo, Habang, Krakatau, Cycloop, Batok, Foka, Idjen, Empong, Goentoer	1887-1892		79-90t, 38.4-39.2x4.0x1.8-2.1m, 1b,1vc, 725-1089hp, 19.1-22.8kts, 16p; 2x1-37/20, 2-450TT
	No.XXIII	1	11	Cerberus	1888		82t, 38.2x4.0x1.8m, 1b,1vc, 912hp, 21.2kts, 16p; 2x1-37/20, (1+2x1)-450TT



	Lamongan	3	12-14	Lamongan, Nobo, Makjan	1891	No picture	59t, 32.9x4.0x1.6m, 1b,1vc, 780hp, 20.4kts, 15p; 2x1-37/20, 2-450TT
TB2cl	No.I	1	1	No.I	1876		29t, 23.2x3.2x1.6m, 1b,1hda, 250hp, 18kts, 11p; 2spar torpedoes
	No.III	1	2	No.III	1876		29t, 23.2x3.2x1.6m, 1b,1hda, 250hp, 18kts, 11p; 2spar torpedoes
	No.II	1	3	No.II	1877		29t, 23.2x3.2x1.6m, 1b,1hda, 250hp, 18kts, 11p; 2spar torpedoes
	No.IV	1	4	No.IV	1879		29t, 23.2x3.2x1.6m, 1b,1hda, 250hp, 18kts, 11p; 2spar torpedoes
	No.V	5	5-9	No.V-IX	1879		29t, 24.6x3.2x1.6m, 1b,1hda, 250hp, 18kts, 11p; 2spar torpedoes
	No.X	3	10-12	No.X, XI, XII Argus	1879		29t, 24.6x3.2x1.6m, 1b,1hda, 250hp, 18kts, 11p; 2spar torpedoes
	No.XIII	6	13-18	No.XIII-XVIII	1879-1881		30t, 24.6x3.2x1.6m, 1b,1hda, 250hp, 17-18kts, 11p; 1x1-37/20(15,16), 2-356TT(15,16), 2spar torpedoes(13,14,17,18)
	No.XIX	2	19, 20	No.XIX, XX	1881		30t, 24.6x3.2x1.6m, 1b,1hda, 250hp, 18kts, 11p; 2spar torpedoes
	No.XXI	2	21, 22	Hekla, Etna	1882		45t, 31.0x3.8x1.7m, 1b,1hc, 550hp, 21.4kts, 15p; 2x1-37/20, 2-356TT
No.III	3	23-24	No.III Jan Haring, No.XXI Jasper Leynssen, No.XXII Jacob Hobein	1891		37t, 25.6x3.2x1.6m, 1b,1vc, 440hp, 17.5kts; 2x1-37/20, 2-356TT	

ESCORTS

AFPV	-	2	1	Dolfijn	1889		
			2	Zeehond	1892		

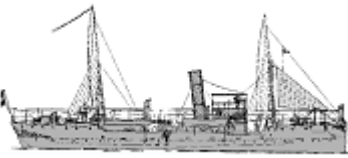
OTHER FIGHTING SHIPS

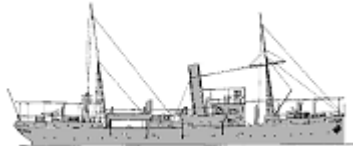
Aruba	1	1	Aruba	1873	No picture	786t, 50.0x9.0x3.8m, 413hp, 9.5kts; 1x1-149/22, 2x1-120/16, 1x1-75/5, 2x1-37/20
Batavia	4	2	Makasser	1877	No picture	853t, 53.6x9.0x3.7m, 400-500hp, 8.4-9.3kts, 84-104p; 1x1-173/22(2), 1x1-149/22(3-5), 2x1-120/16(2), 3x1-120/16(3-5), 2x1-37/20(3-5)
		3	Madura	1880		
		4	Bonaire	1877		
		5	Bali	1878		
Suriname	1	6	Suriname	1877	No picture	884t, 54.0x9.0x3.6m, 450hp, 9.5kts, 90p; 1x1-149/22, 3x1-120/16, 2x1-37/20
Ceram	2	7	Ceram	1887	No picture	541t, 52.8x7.8x3.1m, 800hp, 12.8kts, 83p; 3x1-120/16, 2x1-37/20
		8	Flores	1887		
Lombok	2	9	Lombok	1891	No picture	600t, 52.4x8.3x3.4m, 960hp, 12.3kts, 87p; 3x1-120/16, 2x1-37/20
		10	Sumbawa	1891		
Borneo	1	11	Borneo	1892	No picture	800t, 53.8x9.5x4.1m, 1040hp, 13.2kts, 102p; 6x1-105/32, 2x1-37/20, 2x5-37/17
Nias	4	12	Nias	1895		810-820t, 53.9x9.4x3.7m, 2vte, 1300hp, 12.9kts, 97p; 2x1-105/32, 4x1-37/20, 2x5-37/17
		13	Mataram	1896		
		14	Edi	1897		
		15	Serdang	1897		
Koetei	2	16	Koetei	1898		788t, 53.7x9.4x3.7m, 2vte, 1380hp, 13.7kts, 97p; 2x1-105/32, 4x1-37/20, 2x5-37/17
		17	Siboga	1898		

							
PG	Hydra	9	18	Hydra	1873		221t, 25.9x8.0x2.2m, 2b,1vc, 124-146hp, 7.5-8kts, 34p; 1x1-209/32, 2x1-37/20, 1x5-37/20
			19	Ever	1873		
			20	Das	1876		
			21	Geep	1875		
			22	Gier	1875		
			23	Havik	1874		
			24	Brak	1875		
			25	Lynx	1875		
			26	Sperwer	1875		
	Wodan	16	27	Wodan	1877		264-280t, 27.8x8.2x2.3m, 2b,1vc, 101-171hp, 7-8.3kts, 34p; 1x1-283/27(35,38-41), 1x1-283/20(27-34,36,37,42), 2x1-37/20, 1x5-37/17
			28	Balder	1879		
			29	Braga	1879		
			30	Freyr	1877		
			31	Heimdall	1879		
			32	Njord	1878		
			33	Thor	1877		
			34	Tyr	1878		
			35	Hefring	1880		
			36	Vali	1879		
			37	Vidar	1879		
			38	Bulgia	1884		
			39	Dufa	1879		
			40	Hadda	1880		
			41	Udur	1879		
			42	Ulfr	1879		
	PR	Vahalis	1	1	Vahalis	1870	No picture
Isala		4	2	Isala	1876	No picture	373-388t, 48.6x7.6x1.4m, 306-400hp, 7.7-8kts, 44p; iron- 125side, 25deck, 125turrets; 2x1-120/16
			3	Rhenus	1877		
			4	Mosa	1878		
			5	Merva	1879		

[home](#)

[World navies yesterday](#)

[1900](#)

New Zealand 01 January 1900

TORPEDO SHIPS

TB2cl	Defender	4	1 - 4	Defender, Tairaroa, Waitemata, Poneke	1883 - 1884	No picture	12t, 19.2ppx2.3x1.2m, 1b,1hce, 17kts, 7p; 1x2-25/40, 1-356TT
-------	----------	---	----------	---------------------------------------	-------------	------------	--





Google
Custom Search

© Ivan Gogin, 2014

[home](#)[World navies yesterday](#)[1900](#)

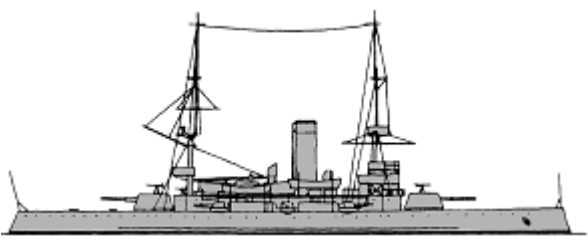
Norway 01 January 1900

BATTLESHIPS





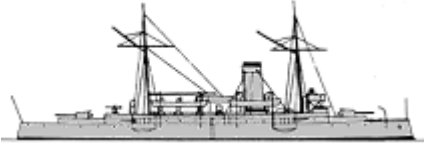
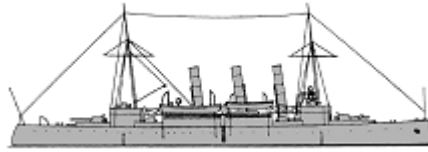



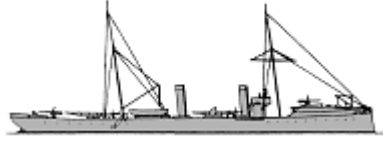

BC	Harald Haarfagre	1	Harald Haarfagre	1898		3858t, 92.7x14.8x5.4m, 3b,2vte, 4000hp, 16.9kts, 245p; Harvey- 178belt, 51deck, 203turrets, 152CT; 2x1-209/44, 6x1-120/44, 6x1-76/40, 6x1-37/45, 2-450TT
		2	Tordenskjold	1898		
MON	Skorpionen	1	Skorpionen	1867		1470t, 61.0x13.9x3.4m, 4b,1vle, 330hp, 6kts, 84p; iron- 125side, 25deck, 305turret; 1x2-120/44, 2x1-65/50, 2x1-37/40
	Mjølner	2	Mjølner	1868		1539t, 62.3x13.9x3.5m, 4b,1vle, 450hp, 8kts, 84p; iron- 125side, 25deck, 305turret; 1x2-120/44, 2x1-65/50, 2x1-37/40
		3	Thrudvang	1869		
Thor	1	4	Thor	1876		2035t, 62.3x14.5x3.8m, 4b,1vle, 600hp, 8kts, 94p; iron- 175side, 25deck, 365turret; 1x2-120/44, 2x1-65/50, 2x1-37/40

CRUISERS

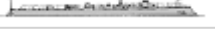
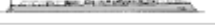

CL	Viking	1	1	Viking	1891		1181t, 63.5x9.3x3.7m, 4b,2vc, 2000hp, 15kts, 125p; Harvey- 35deck, 25shields, 35CT; 2x1-149/37, 4x1-65/50, 4x1-37/20, 1-356TT
	Frithjof	1	2	Frithjof	1896		
							1427t, 68.2x10.0x4.0m, 6b,2vte, 2800hp, 15kts, 154p; Harvey- 30deck; 2x1-120/44, 4x1-76/40, 4x1-37/45, 1-450TT

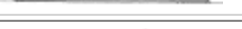

TORPEDO SHIPS

DD	Valkirjen	1	1	Valkirjen	1896		415t, 59.4x7.4x2.6m, 2b,2vte, 3300hp, 23kts, 59p; 2x1-76/40, 4x1-37/45, 2x1-450TT
----	-----------	---	---	-----------	------	--	---

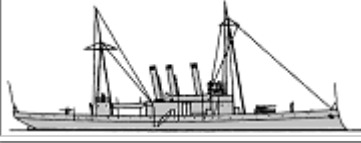
							
TB1cl	Hval	3	1	Hval	1896		102t, 39.9x4.8x2.2m, 2b,1vte, 1100hp, 21kts, 23p; 2x1-37/45, 2x1-450TT
			2	Delfin	1896		
			3	Hai	1896		
	Storm	3	4	Storm	1898		107t, 39.9x4.8x2.2m, 2b,1vte, 1100hp, 21kts, 23p; 2x1-37/45, 2x1-450TT
			5	Brand	1898		
			6	Trods	1898		
TB2cl	Rap	1	1	Rap	1873		15t, 17.3x2.3x0.9m, 1b,1hda, 90hp, 15kts, 6p; 2-356TC
	Ulven	1	2	Ulven	1878		16t, 17.2x2.9x1.1m, 1b,1hda, 70hp, 10kts, 6p; 2-356TC
	Od	1	3	Od	1882		41t, 29.0xxm, 1b,1vc, 420hp, 18kts; 1x1-37/20, 1-356TT
	Springer	1	4	Springer	1883		44t, 30.0xxm, 1b,1vc, 420hp, 18kts; 1x1-37/20, 2-356TT
	Rask	2	5, 6	Rask, Pil	1885-1886		44t, 30.5xxm, 1b,1vc, 500hp, 19kts; 1x1-37/20, 2-356TT
	Snar	1	7	Snar	1887		49t, 32.0xxm, 2b,1vc, 600hp, 19kts; 1x1-37/20, 2-356TT
	Orm	2	8, 9	Orm, Oter	1888		54t, 33.0xxm, 2b,1vc, 600hp, 19kts; 1x1-37/20, 2-381TT
	Varg	2	10, 11	Varg, Raket	1894		64t, 34.5x3.8x1.6m, 2b,1vte, 650hp, 19kts, 12p; 1x5-37/12, 2-450TT
	Lyn	3	12-14	Lyn, Blink, Glimt	1896-1897		64t, 34.5x3.8x1.8m, 2b,1vte, 650hp, 19kts, 21p; 1x1-37/45, (1+1x1)-450TT
	Djerv	3	15-17	Djerv, Kvikk, Dristig	1897-1898		66t, 34.5x3.8x1.7m, 2b,1vte, 650hp, 19kts, 21p; 2x1-37/45, (1+1x1)-450TT

OTHER FIGHTING SHIPS

PG	Sarpen	1	1	Sarpen	1861	No picture	220t; 2x1-65/50, 2x1-37/45
	Glommen	2	2	Glommen	1864	No picture	280t, 41.1xxm, 180hp, 9kts; 1x1-167/17, 1x1-155/17, 4x1-87/17
			3	Lougen	1864		
	Trold	1	4	Trold	1872	No picture	97t, 65hp, 7.5kts; 1x1-155/17
	Dverg	16	5-20	Dverg, Nøk, Aasgaardstrand, Kongsberg, Kristiansand, Skudesnes, Karmøe, Skien, Tønsberg, Horten, Langesund, Porsgrund, Laurvig, Arendal, Lillesand, Brevig	1872-1883	No picture	55t, 70hp, 7.5kts; 1x1-155/17
	Vale	2	21	Vale	1874		229t, 27.3x7.9x2.2m, 2b,2vc, 200hp, 8kts, 38p; 1x1-267/14, 1x1-37/20, 2x5-37/17
			22	Uller	1877		
	Sleipner	1	23	Sleipner	1878		720t, 53.3x7.9x3.4m, 2vc, 650hp, 12kts, 90p; 1x1-263/20, 1x1-149/22, 1-356TT
	Brage	2	24	Brage	1879		264t, 28.9x7.9x2.2m, 2b,2vc, 220hp, 8.5kts, 38p; 1x1-267/14, 1x1-37/20, 2x5-37/17, 1-356TT(25)
			25	Nor	1879		
	Vidar	1	26	Vidar	1882		262t, 28.9x7.9x2.2m, 2b,2vc, 330hp, 9.5kts, 38p; 1x1-267/17, 1x1-37/20, 2x5-37/17

							
Ellida	1	27	Ellida		1882	No picture	1045t, 58.0x9.9x4.4m, 2vc, 900hp, 10.5kts, 130p; 2x1-76/40, 1x1-75/52, 2x1-65/50, 2x1-37/45
Gor	2	28	Gor		1885		290(28)-278(29)t, 31.3x8.5x2.2m, 2b,2vc, 420hp, 10.5kts, 44p; 1x1-263/17, 1x1-57/40(29), 1x1-37/20(28), 2x5-37/17, 1-356TT
		29	Tyr		1887		
Æger	1	30	Æger		1894		413t, 33.2x8.8x2.4m, 2b,2vte, 350hp, 9kts, 43p; 38deck; 1x1-209/35, 1x1-65/50, 2x1-47/40

FISHERY PROTECTION VESSELS

FPV		Heimdal		1	1	Heimdal	1892	No picture	640t; 4x1-76/40
-----	--	---------	--	---	---	---------	------	------------	-----------------



© Ivan Gogin, 2014

[home](#)[World navies yesterday](#)[1900](#)

Ottoman Empire 01 January 1900

BATTLESHIPS

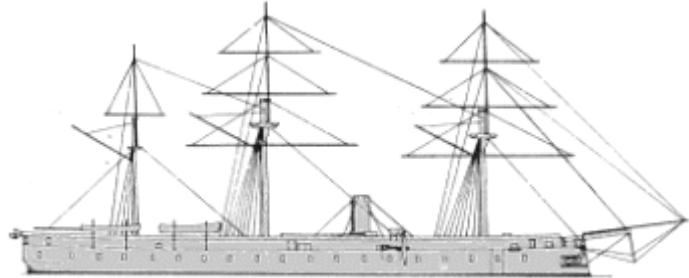
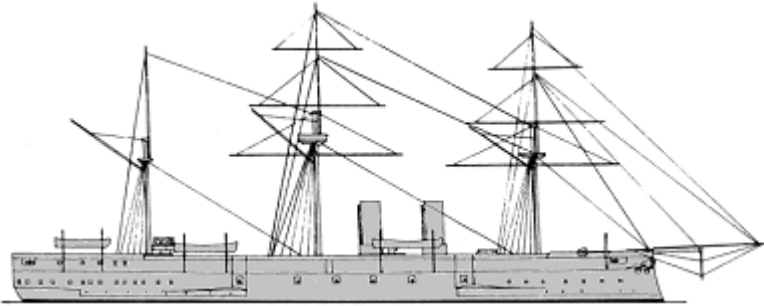
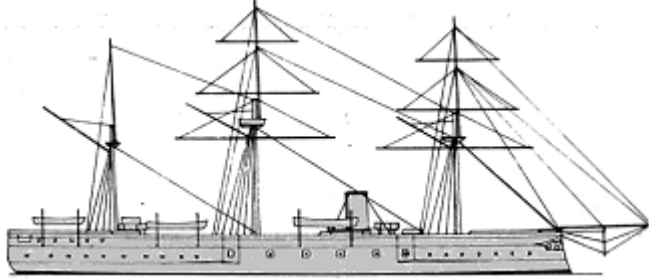
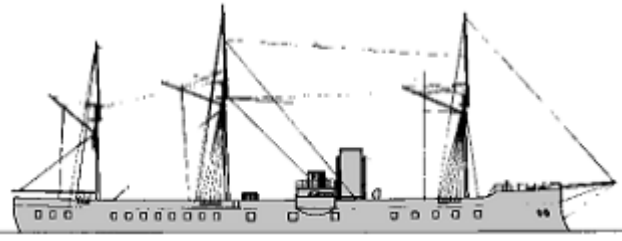
		1	Osmaniye	1865		<p>6400t, 91.4x17.0x7.9m, 6b,vte, 3735hp, 10kts, 361p; iron- 140belt, 127battery; 2x1-235/32, 8x1-149/22, 5x1-105/32, 2x1-47/40, 7x4-25/42</p>	
		2	Aziye	1865			
		3	Orhaniye	1866			
	Osmaniye	4	Mahmudiye	1866			
BB	Mesudiye	1	5	Mesudiye	1875		<p>8938t, 102.4x17.9x7.9m, 8b,1hse, 7431hp, 13.7kts, 700p; iron- 305belt, 254battery, 203CT; 12x1-254/15, 3x1-178/16, 6x1-75/37, 6x1-25/42</p>
	Hamidiye	1	6	Hamidiye	1894		<p>6594t, 89.0x17.0x7.6m, 4b,1hse, 6800hp, 13kts, 350p; iron- 229belt, 178battery, 178CT; 4x1-229/14, 10x1-149/32</p>
	Asar-i Tevfik	1	1	Asar-i Tevfik	1870		<p>4687t, 83.0ppx16.0x6.5m, 6b,1hc, 3560hp, 13kts, 320p; iron- 203belt, 152battery; 6x1-229/14, 2x1-209/32, 2x1-87/22, 2x1-57/37, 2x1-25/42</p>
		2	Asar-i Şevket	1870			

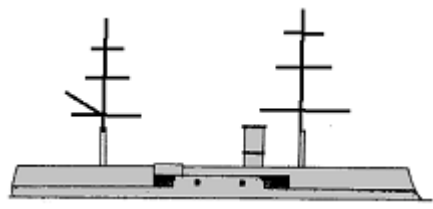
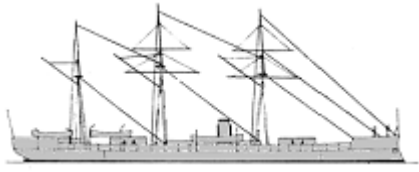
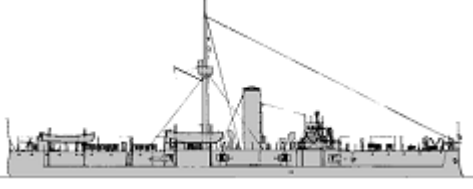
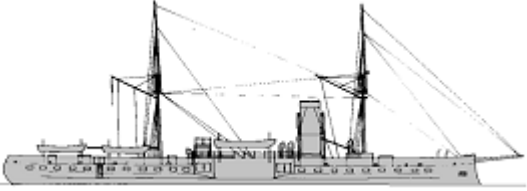
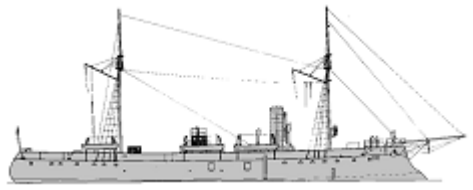
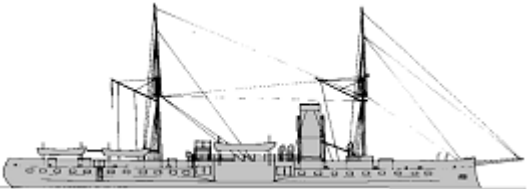

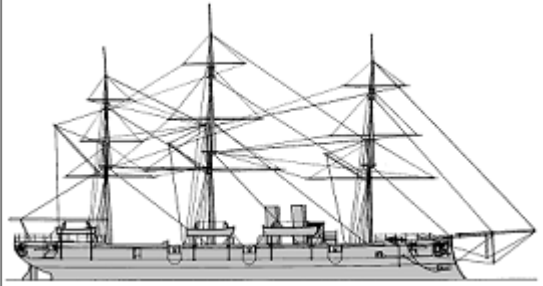

BC	Asar-i Şevket	2	3	Necm-i Şevket	1870		2047t, 66.4x13.0x5.0m, 4b,1hc, 1750(2)-1900(3)hp, 12kts, 170p; iron- 152belt, 114battery; 1x1-229/14, 4x1-178/16, 2x1-87/22, 2x1-57/37, 2x5-37/27, 1x1-25/42, 1x1-356TT(3)
	Hifz-ur Rahman	1	4	Hifz-ur Rahman	1870		2540t, 64.4x13.6x4.4m, 2b,2hc, 2000hp, 12kts, 122p; iron- 140belt, 38deck, 140turrets; 1x2-203/15, 1x1-149/22, 1x1-120/22, 4x1-37/37, 2x4-25/42
	Avnillah	2	5	Avnillah	1870		2362t, 71.9x11.0x5.0m, 4b,1hc, 2200hp, 12kts, 145p; iron- 152belt, 127casemates; 4x1-203/15, 2x1-87/22
			6	Muin-i Zafer	1870		
	Feth-i Bülend	1	7	Feth-i Bülend	1870		2762t, 72.0ppx12.0x5.5m, 6b,1hc, 3250hp, 13kts, 169p; iron- 229belt, 229casemates; 4x1-229/14, 2x1-87/22, 2x1-57/37, 2x5-37/27, 1x1-25/42
	İclaliye	1	8	İclaliye	1871		2228t, 66.0x13.0x5.3m, 2b,1hc, 1800hp, 12kts, 148p; iron- 152belt, 114battery; 2x1-229/14, 2x1-178/16, 1x1-149/32, 2x1-87/22, 2x1-57/37, 2x5-37/27, 2x1-25/42
Mukaddeme-i Hayir	1	9	Mukaddeme-i Hayir	1874		2762t, 72.0ppx12.0x5.5m, 4b,1hc, 3000hp, 12kts, 169p; iron- 229belt, 229casemates; 4x1-229/14, 2x1-87/22, 2x1-57/37, 2x5-37/27, 2x1-25/42	

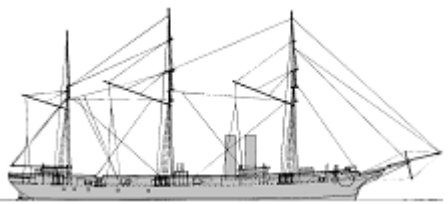
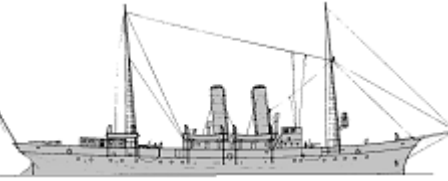
CRUISERS

CL	Heybetnüma	1	1	Heybetnüma	1895		1958t, 68.9ppx11.3x5.2m, 6b,1hte, 2786hp, 12kts, 190p; 2x1-149/22, 2x1-120/22, 4x1-47/37
	Sinop	2	1	Sinop	1860	No picture	787t, 53.2ppx9.3x4.5m, 2b,1hse, 640hp, 11kts, 150p; 2x1-149/22(2), 2x1-120/22(2), 3x1-50/22(1), 3x1-37/20, 2x1-25/42(2)
			2	Edirne	1859		
			3	Beyrut	1860		

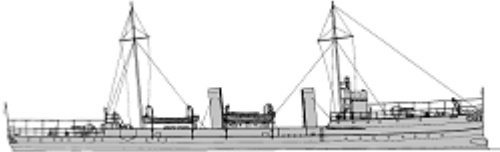
CLL	Beyrut	3	4	İskenderiye	1863		599t, 52.9ppx8.1x3.9m, 2b,1hse, 450hp, 10kts, 120p; 2x1-120/22, 2x1-76/19(4,5), 4x1-37/20(3), 2x1-25/42(4,5)
			5	Meriç	1864		
			6	Mansure	1864		
	Mansure	2	7	Muzaffer	1864	No picture	783bm, 55.1x9.3x4.4m, 2b,1hse, 650hp, 10kts, 130p; 2x1-149/22, 2x1-120/22, 3x1-37/20, 2x1-25/42
			8	Zuhaf	1896		
	Zuhaf	2	9	Kilid Bahir	1896		643t, 57.9ppx7.3x3.5m, 2b,1vte, 640hp, 14kts, 82p; 1x1-120/22, 4x1-37/37
10			Lütf-ü Hümayun	1896	No picture		

TORPEDO SHIPS

PGT	Peleng-i Derya	1	1	Peleng-i Derya	1896		900t, 75.5x8.5x2.9m, 4b,2vte, 4700hp, 18kts, 80p; 2x1-105/32, 6x1-47/37, 5x5-37/27, (1+2x1)-356TT
TB	Burhaneddin	2	1, 2	Burhaneddin, Tevfik	1885		42t, 31.7x3.6x1.7m, 1b,1vc, 525hp, 17kts, 24p; 1x4-34/42, 1x4-25/42, 2-356TT, 1spar torpedo
	Gilyum	5	3-7	Gilyum, Saiki, Tir-i Zafer, Seyf-i Bahri, Vesile-i Nusret	1886		85t, 37.7x4.8x2.0m, 1b,1vte, 980hp, 21kts, 18p; 2x5-37/27, 2-356TT
	Mecidiye	3	8-10	Mecidiye, Eser-i Terakki, Nimet	1889-1893		42t, 31.7x3.6x1.7m, 1b,1vc, 450hp, 15kts, 24p; 1x4-34/42, 1x4-25/42, 2-356TT
	Nasir	7	11-17	Nasir, Fatih, Nusret, Şahab, Tarik, Pervın, Seham	1889-1890		87t, 39.0x4.8x2.6m, 1b,1vte, 1200hp, 21kts, 27p; 2x5-37/27, 2-356TT
	Ejder	1	18	Ejder	1893	No picture	150t, 49.2x5.7x2.2m, 2b,2vte, 2200hp, 24kts, 22p; 5x5-37/27, (1+1x1)-356TT
	Berk Efşan	2	19-20	Berk Efşan Tayyar	1894 1894	No picture	230t, 59.9x6.6x2.4m, 2b,2vte, 3500hp, 21kts, 50p; 6x5-37/27, 2-428TT

OTHER FIGHTING SHIPS

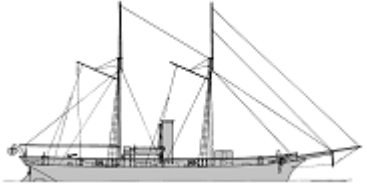
Akka	3	1	Akka	1859		120t, 35.4x6.0x2.7m, 1b,1vte(2)-1b,1hsa(1,3), 400(2)-225(1,3)hp, 10(2)-8(1,3)kts, 45(2)-70(1,3)p; 4x1-155/14(3), 1x1-125/14(3), 4x1-75/37(2), 3x1-75/22(1), 1x1-37/37(1,2)
		2	Şevket Nüma	1860		
		3	Necmifeşan	1860		
Musul	1	4	Musul	1866		125t, 39.9ppx6.4x2.8m, 1b,1hsa, 9kts, 35p; 2x1-57/27, 2x5-37/17

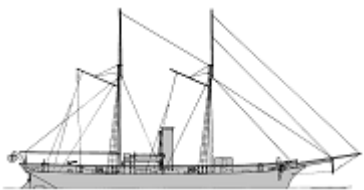
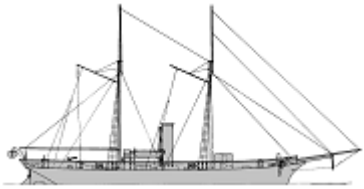
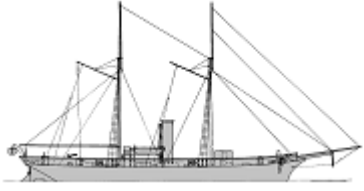
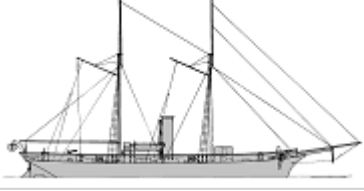
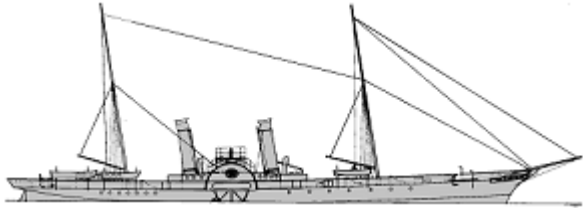
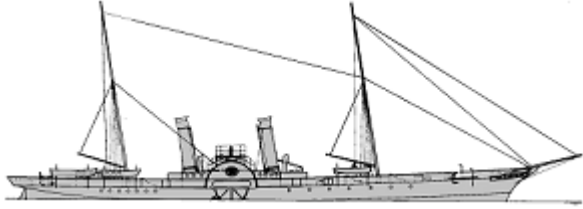
PG							
	Sahir	1	5	Sahir	1866		163t, 40.4ppx6.7x3.2m, 1b,1hsa, 8kts, 35p; 2x1-75/18, 2x5-37/17
	İntibah	2	6	Müjderesan	1866		163t, 40.4ppx6.7x3.2m, 1b,1hsa, 12kts, 35p; 4x1-75/18, 2x5-37/17
			7	Ziver-i Derya	1866		
	Saheddin	1	8	Saheddin	1866		163t, 40.4ppx6.7x3.2m, 1b,1hsa, 12kts, 35p; 4x1-75/18, 2x5-37/17
	Aynalıkavak	1	9	Aynalıkavak	1869	No picture	195t, 35.9ppx5.3x1.8m, 1b,1hsa, 10kts, 35p; 1x1-57/37, 2x5-37/17
	Rodos	1	10	İstanköy	1874	No picture	203bm, 35.7ppx5.3x1.8m, 1b,1hsa, 12kts, 35p; 2x1-57/37, 2x5-37/17
	Firat	2	11	Firat	1885	No picture	197t, 37.0ppx6.5x2.4m, 1b,1hc, 280hp, 10kts, 55p; 2x1-88/27, 1x1-47/37, 1x1-37/20
			12	Şat	1885		
	Sulhiye	1	13	Sulhiye	1868	No picture	161t, 36.5x5.7x2.3m, 1b,1hda(sw); 2x1-small guns
Sarıye	3	14	Sarıye	1869	No picture	103t, 30.9x7.5x2.3m, 1b,1hda(sw)	
		15	Nedim	1869			
		16	Bozcaada	1869			
APG	-	1	1	Gemlik	1848		219t
DV	İzzeddin	1	1	İzzeddin	1865		1058t, 76.2ppx9.1x3.6m, 2b,1hda(sw), 200hp, 17kts, 130p; 1x1-120/19, 3x1-75/19
	Fuad	1	2	Fuad	1865		1075t, 76.2ppx9.1x3.6m, 2b,1hda(sw), 200hp, 12kts, 130p; 2x175/37, 2x1-25/42
ADV	-	2	1	Hanya	1863		816t
			2	Resmo	1862		765t

RMON	Feth-ül İslam	2	1	Feth-ül İslam	1865	No picture	335t, 31.5x9.8x1.7m, 2b,2hse, 290hp, 8kts, 50p; iron- 76belt, 76battery, 13CT; 2x1-178/16(1), 2x1-76/18
			2	Memduhiye	1865		
	Hizber	1	3	Hizber	1876	No picture	404t, 43.9ppx9.4x1.6m, 1b,1hse, 400hp, 8kts, 51p; iron- 76belt, 76battery, 13CT; 2x1-120/22, 2x1-87/22, 2x1-25/42
AGS	-	2	1	İskenderun	1895		142t
			2	Sakiz	1895		142t

© Ivan Gogin, 2015

[home](#)[World navies yesterday](#)[1900](#)

Persia 01 January 1900

OTHER FIGHTING SHIPS

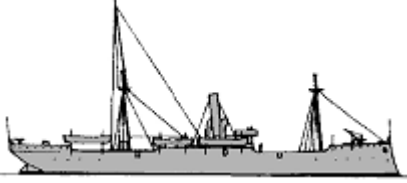
PG	Persepolis	1	1	Persepolis	1885		1200t, 63.1x10.0x5.9m, 1vte, 450hp, 10kts; 4x1-66/26
	Muzaffer	1	2	Muzaffer	1899	No picture	379t, 41.1x7.9x4.0m
PGR	Susa	1	1	Susa	1885	No picture	

© Ivan Gogin, 2015

[home](#)[World navies yesterday](#)[1900](#)

Peru 01 January 1900

CRUISERS

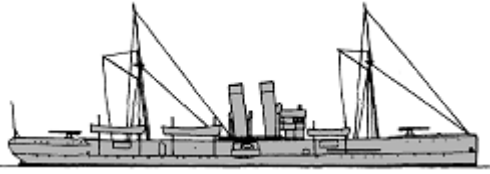
CL	Apurimac	1	1	Apurimac	1850	No picture	1000t; 34guns
CLL	Lima	1	1	Lima	1888		1790t, 76.2x10.7x4.6m, 4b,2hc, 1800hp, 16.2kts, 150p; 2x1-152/26, 3x1-47/40

OTHER FIGHTING SHIPS

PG	Santa Rosa	1	1	Santa Rosa	1883	No picture	2x1-152/26
PGR	Iquitos	1	1	Iquitos	1875	No picture	50t, 23.4x3.7x1.2m, 7.5kts; 1x1-47/40

© Ivan Gogin, 2015

[home](#)[World navies yesterday](#)[1900](#)

Portugal 01 January 1900

BATTLESHIPS

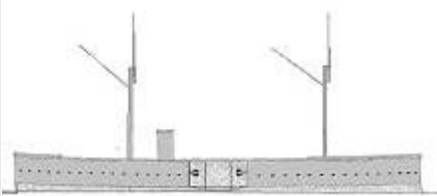
BC	Vasco da Gama	1	1	Vasco da Gama	1876		2384t, 61.0ppx14.2x5.8m, 2vc, 3000hp, 10.3kts, 232p; iron- 229belt, 254battery; 2x1-163/18, 1x1-149/22, 4x1-67/40
----	---------------	---	---	---------------	------	--	---

CRUISERS

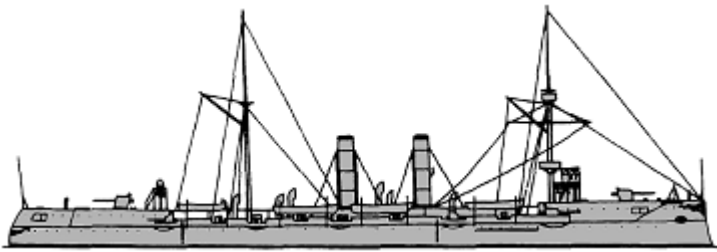
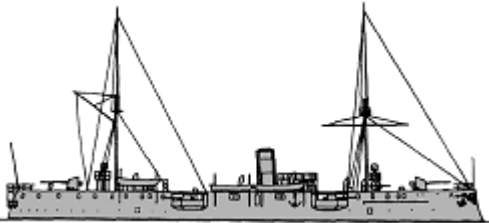
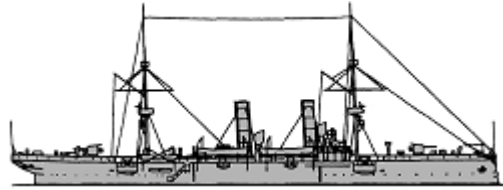
CL	Bartolomeu Dias	1	1	Bartolomeu Dias	1858	No picture	2377t, 63.1ppx11.4x6.3m, 1hr, 400hp, 10kts, 473p; 5x1-127/25
	Dom Carlos I	1	2	Dom Carlos I	1898		4253t, 117.0x14.4x5.3m, 12b,2vte, 12500hp, 22kts, 473p; 110slopes, 37deck, 102CT; 4x1-152/45, 8x1-120/44, 16x1-47/40, 2x1-37/25, 5-356TT
	São Gabriel	2	3	São Gabriel	1899		1771t, 75.0x10.8x4.3m, 4b,2vte, 4000hp, 17.5kts, 242p; 20deck, 60CT; 2x1-149/45, 4x1-120/45, 8x1-47/40, 2x1-37/20, 1-356TT
	4	São Rafael	1899				
CLL	Duque da Terceira	1	1	Duque da Terceira	1864	No picture	1406t, 54.9ppx10.4x4.5m, 660hp, 10kts, 194p; 2x1-120/44, 2x1-65/40
	Afonso d'Albuquerque	1	2	Afonso d'Albuquerque	1884	No picture	1092t, 62.0ppx10.1x3.7m, 1360hp, 13kts, 178p; 2x1-152/26, 5x1-127/25, 2x1-47/40
	Adamastor	1	3	Adamastor	1897		1757t, 74.0ppx10.7x4.7m, 4b,2vte, 4000hp, 18kts, 237p; 30deck, 65CT; 2x1-149/27, 4x1-105/37, 4x1-65/40, 2x1-37/25, 3-356TT

TORPEDO SHIPS

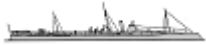
TB	Fulminante	1	1	Fulminante	1880	No picture	40t, 22.9ppx4.6x0.8m, 1b,1vc, 150hp, 11.5kts; 2spar torpedoes
	Espadarte	1	2	N°1	1881	No picture	53t, 26.2ppx3.4x1.5m, 1b,1vc, 450hp, 19.7kts, 18p; 2-356TT
	N°2	3	3-5	N°2-4	1886		65t, 36.5ppx3.9x1.0m, 1b,1vc, 700hp, 19kts; 2x5-37/17, 2-356TT

SUBMARINES

SS	Plongeur	1	1	Plongeur	1892	No picture	/100t, 22.0x3.5xm, 2em, /6kts, 6p; 4-356TC
----	----------	---	---	----------	------	------------	--

OTHER FIGHTING SHIPS

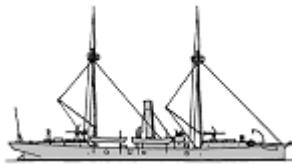
PG	Tejo	1	Tejo	1869	No picture	578t, 43.6ppx7.9x3.3m, 1b,1hse, 400(1,2)-500(3)hp, 10(1,3)-9(2)kts, 109p; 1x1-163/14(2,3), 2x1-121/14, 1x1-100/27(1)	
		2	Douro	1873			
		3	Quanza	1877			
	Rio Lima	1	4	Rio Lima	1875	No picture	628t, 45.4x8.6x3.2m, 500hp, 11kts, 109p; 1x1-152/26, 2x1-100/27
	Rio Tâmega	2	5	Rio Tâmega	1875	No picture	635t, 45.4ppx8.6x3.2m, 500hp, 11kts, 109p; 2x1-105/32, 2x1-65/40, 1x1-37/20
			6	Rio Sado	1875		
	Tavira	2	7	Tavira	1878	No picture	160t
			8	Faro	1878		
	Mandovi	2	9	Bengo	1879	No picture	462t, 38.2ppx7.5x2.7m, 400hp, 10.5kts, 92p; 1x1-152/26, 2x1-87/21
			10	Mandovi	1879		
	Rio Vouga	1	11	Rio Vouga	1882	No picture	721t, 49.1ppx8.4x3.6m, 600hp, 10kts, 121p; 2x1-47/40
	Vilhena	1	12	Vilhena	1882	No picture	160t, 29.0x4.9x1.8m, 310hp, 12kts, 42p; 1x1-76/16
	Liberal	2	13	Liberal	1884	No picture	560t, 42.5ppx7.9x3.4m, 500hp, 10kts, 109p; 1x1-152/26, 2x1-100/27, 1x1-37/20
			14	Zaire	1884		
	Massabi	2	15	Massabi	1884	No picture	280t, 37.0ppx5.9x2.0m, 375hp, 11kts, 42p; 1x1-76/16
			16	Cacongo	1886		
	Zambeze	1	17	Zambeze	1886	No picture	631t, 43.6ppx7.9x3.3m, 460hp, 10kts, 113p; 3x1-100/27, 1x1-37/20
	Diu	1	18	Diu	1889	No picture	730t, 45.0ppx8.2x4.0m, 700hp, 11.5kts, 124p; 1x1-149/27, 2x1-105/32
	Limpopo	1	19	Limpopo	1890	No picture	288t, 37.8x6.4x2.0m, 1b,1vc, 520hp, 11.3kts, 42p; 1x1-65/40
	D. Luiz	1	20	D. Luiz	1895	No picture	789t, 45.9ppx8.3x4.2m, 500hp, 10kts, 120p; 4x1-105/32, 2x1-47/40
	Thomaz Andrea	2	21	Thomaz Andrea	1896	No picture	300t, 41.0ppx8.0x2.0m, 500hp, 12kts; 2x1-47/40
			22	Al. Baptista de Andrade	1897		
	Chaimite	1	23	Chaimite	1898		341t, 41.0ppx8.0x2.0m, 2vte, 480hp, 11kts, 26p; 2x1-47/40
PR	Pedro d'Annaia	3	1-3 Pedro d'Annaia, Diogo Cão, Honório Barreto	1895	No picture	93t, 30.0ppx6.0x0.8m, 500hp, 9kts; 2x1-47/40	

[home](#)[World navies yesterday](#)[1900](#)

Romania 01 January 1900

CRUISERS

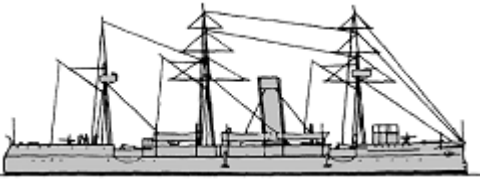
CL	Elisabeta	1	1	Elisabeta	1888		1300t, 73.0x10.2x3.7m, 4b,2vte, 4700hp, 17.3kts, 190p; steel- 86slopes, 43deck; 4x1-149/32, 4x1-57/42, 4x1-37/20, 4-356TT
----	-----------	---	---	-----------	------	--	---

TORPEDO SHIPS

TB	Năluca	3	1-3	Năluca, Sborul, Smeul	1888	No picture	56t, 36.8x3.5x0.9m, 1b,1vc, 540hp, 16kts, 20p; 2x5-37/17, 2-356TT, 1spar torpedo
----	--------	---	-----	-----------------------	------	------------	--

OTHER FIGHTING SHIPS

PG	Grivița	1	1	Grivița	1880	No picture	110t, 60.5x5.2x1.8m, 180hp, 9kts, 30p; 2x1-57/42, 2x1-37/42
PGR	Rahova	3	1-3	Rahova, Smardan, Opanezul	1882	No picture	45t, 8.5kts; 1x1-37/20
	Oltul	3	4	Oltul	1888	No picture	116t, 30.5x4.1x1.7m, 380hp, 13kts, 30p; 1x1-57/42, 1x1-37/42
			5	Siretul	1888		
			6	Bistrița	1888		
	Alexandru cel Bun	1	7	Alexandru cel Bun	1882	No picture	104t
Monteano	3	8-10	Monteano, Olteano, Imeo	1893	No picture	95t, 13.5kts; 1x1-57/42, 2x1-37/42	

© Ivan Gogin, 2015



[home](#)[World navies yesterday](#)[1900](#)



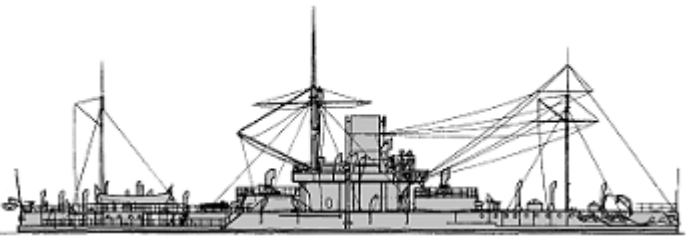
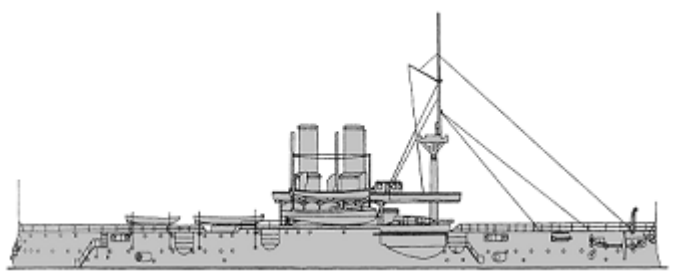
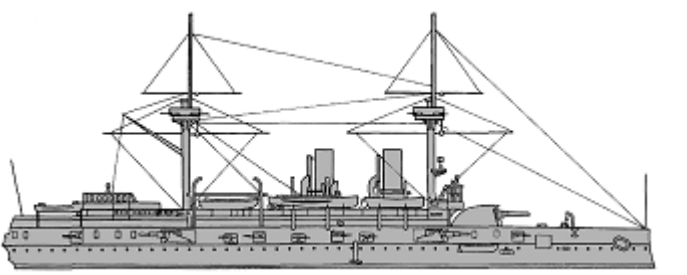
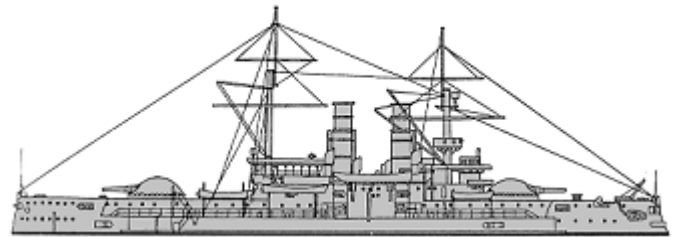

Russia 01 January 1900

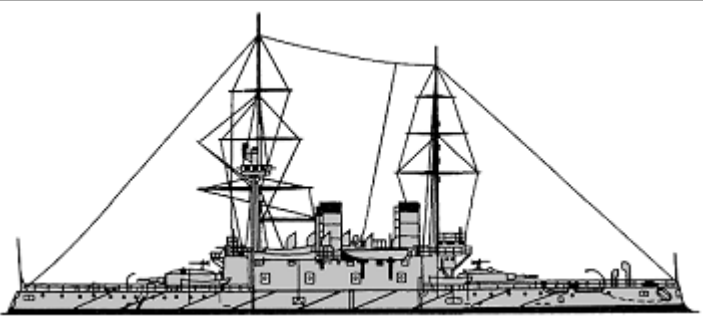
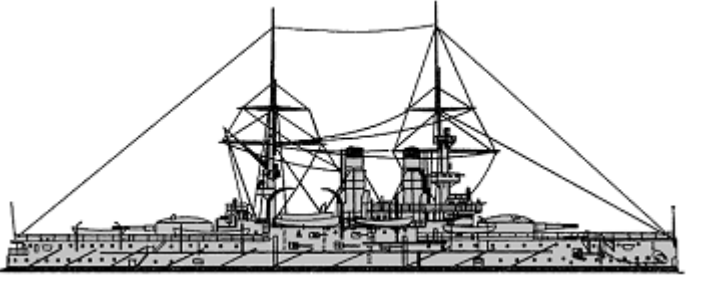
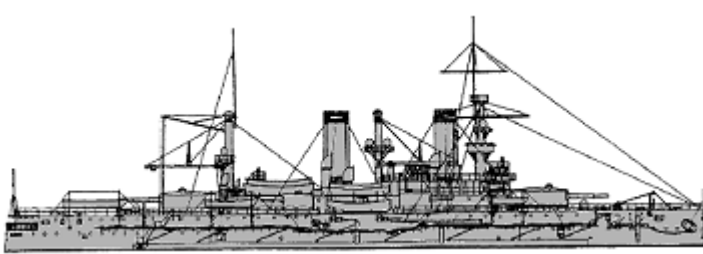
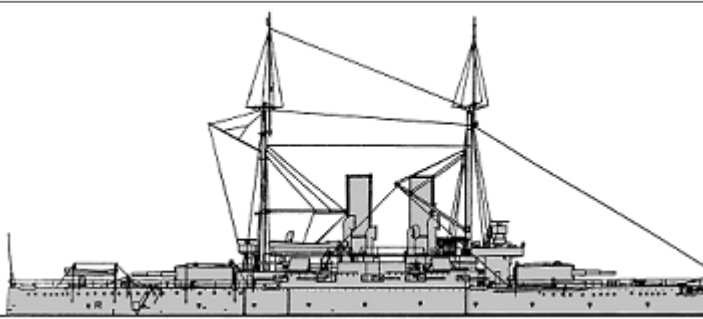
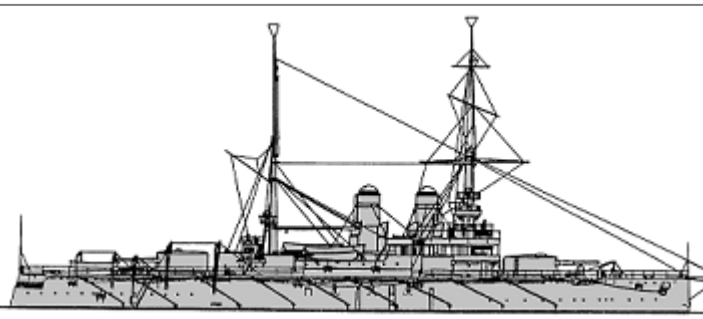
BATTLESHIPS

Pyotr Velikiy	1	1	Pyotr Velikiy	1876		10460t, 103.5x19.0x8.3m, 12b,2vc, 8250hp, 14.3kts, 440p; iron- 356belt, 76deck, 356turrets; 2x2-305/17, 4x1-87/17, 6x1-47/40, 4x5-37/17, 2x4-25/40, 2-381TT
Yekaterina II	4	2	Yekaterina II	1888		11048(2)-10930(3)-10181(4)-10750(5)t, 103.5x21.0x8.8m, 14b,2vc(2,3)-16b,2vte(4,5), 9100(2,3)-13000(4,5)hp, 15(2,3)-16(4)-16.5(5)kts, 633-645p; compound(2-4)-steel(5), 406belt, 38(2)-57(3-5)deck, 305redoubt, 292(2-4)-305(5)CT; 3x2-305/27(2,4), 3x2-305/32(3,5), 7x1-152/32, 2x1-63/17(3-5), 8x1-47/40(5), 8x5-47/22(2-4), 10x1-37/20(5), 4x5-37/17(2-4), 7-381TT, 100mines
		3	Chesma	1889		
		4	Sinop	1889		
		5	Georgiy Pobedonosets	1893		
Imperator Aleksandr II	2	6	Imperator Aleksandr II	1890		10010(6)-9672(7)t, 105.6x20.4x7.8m, 12b,2vc(6)-12b,2hte(7), 8500hp, 15.3kts, 616p; compound- 356belt, 63deck, 254barbette(6), 254turret(7), 254(6)-203(7)CT; 1x2-305/27, 4x1-229/32, 8x1-152/32, 4x1-63/17(6), 2x1-63/17(7), 10x5-47/22, 8x5-37/17, 5-381TT(6), 6-381TT(7)
		7	Imperator Nikolay I	1891		
Dvenadtsat Apostolov	1	8	Dvenadtsat Apostolov	1892		8709t, 104.2x18.3x8.4m, 8b,2vte, 8750hp, 15.7kts, 599p; compound- 356belt, 63deck, 305barbettes, 203CT; 2x2-305/27, 4x1-152/32, 12x1-47/40, 10x1-37/20, 4x5-37/17, 6-381TT
Navarin	1	9	Navarin	1896		10206t, 109.0x20.4x8.4m, 12b,2vte, 9140hp, 15.5kts, 622p; compound- 406belt, 76deck, 305turrets, 254CT; 2x2-305/32, 8x1-152/32, 2x1-63/17, 8x1-47/40, 15x1-37/20, 6-381TT

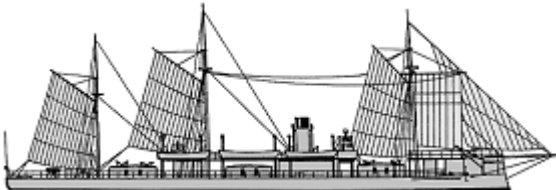
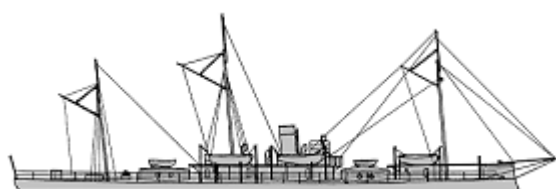
BB

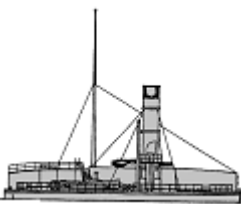
						
Sisoy Velikiy	1	10	Sisouy Velikiy	1896		10400t, 107.2x20.7x7.8m, 12b, 2vte, 8500hp, 15.7kts, 582p; NS- 406belt, 76deck, 305turrets, 203CT; 2x2-305/38, 6x1-152/44, 2x1-63/17, 12x1-47/40, 12x5-37/17, 6-381TT
Poltava	3	11	Poltava	1896		11500(11)-11354(12)-11842(13)t, 114.3x21.3x7.9m, 14b,2vte(11,12)-16b,2vte(13), 10600hp, 16.5kts, 652p; NS(12)-Harvey(13) 368(11,13)-406(12)belt, 76deck, 254turrets, 229CT; 2x2-305/38, (4x2+4x1)-152/44, 12x1-47/40(11,13), 10x1-47/40(12), 28x1-37/20, 2-450TT, 4-381TT, 50mines
		12	Petropavlovsk	1897		
		13	Sevastopol	1898		
Tri Svyatitelya	1	14	Tri Svyatitelya	1897		13318t, 115.1x22.3x8.7m, 14b,2vte, 11300hp, 753p; Harvey+NS- 457belt, 76deck, 406turrets, 305CT; 2x2-305/38, 14x1-152/44, 4x1-120/43, 2x1-63/17, 10x1-47/40, 10x1-37/20, 6-381TT
Rostislav	1	15	Rostislav	1898		10140t, 107.2x20.7x6.7m, 12b,2vte, 8700hp, 15.6kts, 632p; Harvey- 356belt, 76deck, 254turrets, 152CT; 2x2-254/43, 4x2-152/44, 2x1-63/17, 12x1-47/40, 14x1-37/20, 6-381TT
Pervenets	3	1	Pervenets	1863		4000t, 67.6(1)-69.4(2)-67.3(3)x16.2x4.6m, 2b,1hda(1)-4b,1hda(2,3), 1067(1)-1232(2)-870(3)hp, 8(1,2)-9(3)kts, 394-459p; iron- 114belt, 29deck(3), 114battery, 114CT(2,3); 6x1-203/19(1), 12x1-203/19(2), 8x1-203/19(3), 2x1-152/32(1), 4x1-152/25(1), 2x1-152/25(2), 7x1-152/32(3), 2x1-120/43(1), 1x1-107/17(1), 2x1-87/17(1), 2x1-63/17, 2x1-47/40(1), 4x1-47/40(3), 4x1-37/20(3), 5x5-37/17(1)
		2	Ne Tron Menya	1865		
		3	Kreml	1867		

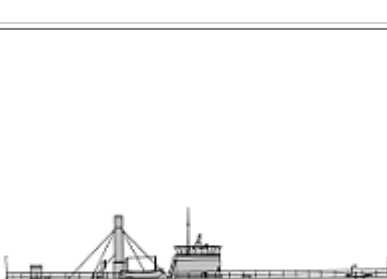
BC	Smerch	1	4	Smerch	1865		1460t, 57.4x11.6x3.7m, 2b,2hda, 700hp, 8kts, 155p; iron- 114side, 25deck, 152turrets; 2x1-229/19, 4x1-87/21, 4x5-37/17
	Admiral Lazarev	2	5	Admiral Lazarev	1869		3820(5)-3768(6)t, 77.7x13.1x6.2m, 4b,1hda, 2020hp, 10.5(5)-11(6)kts, 274p; iron- 114side, 114turrets, 127CT; 3x1-279/18, 2x1-63/17, 5x1-47/40, 2x1-37/20
			6	Admiral Greyg	1869		
	Admiral Spiridov	2	7	Admiral Spiridov	1869		3925(7)-3851(8)t, 77.5x13.1x6.2m, 4b,1hda, 2030hp, 10.5kts, 260p; iron- 152side, 152(7)-178(8)turrets; 2x1-279/18, 2x1-63/17, 1x1-47/40, 4x1-37/20
			8	Admiral Chichagov	1869		
	Rusalka	1	9	Charodeyka	1869		2100t, 62.9x12.8x3.8m, 2b,2hda, 875hp, 8.5kts, 178p; iron- 114side, 25deck, 152turrets; 2x2-229/19, 4x1-87/17, 5x5-37/17
	Novgorod	1	10	Novgorod	1874		2491t, 30.8x30.8x4.1m, 8b,4hc, 2000hp, 6kts, 149p; iron- 229sides, 70deck, 229barbette; 1x2-279/17, 2x1-87/17, 2x5-37/17
	Vitse-Admiral Popov	1	11	Vitse-Admiral Popov	1876		3550t, 36.6x36.6x4.1m, 8b,4hc, 3066hp, 6kts, 203p; iron- 406sides, 76deck, 406barbette; 1x2-305/17, 6x1-87/17, 2x5-37/17
Admiral Ushakov	3	12	Admiral Ushakov	1897		4648(12)-4792(13)-4152(14)t, 86.4x15.9x6.1m, 4b,2hte, 4250hp, 16(12,13)-15(14)kts, 406p; Harvey- 254belt, 51deck, 178turrets, 178CT; 2x2-254/43(12,13), (1x2+1x1)-254/43(14), 4x1-120/43, 2x1-63/17, 6x1-47/40(12,13), 10x1-47/40(14), 18x1-37/20(12,13), 12x1-37/20(14), 4-381TT	
		13	Admiral Senyavin	1897			
		14	General-Admiral Apraksin	1899			
MON	Bronenosets	10	1	Bronenosets	1865		1565t, 61.3x14.0x3.8m, 2b,1hda, 340-530hp, 6.5-8kts, 111p; iron- 229side, 25(10)deck, 254turret, 203CT; 1x2-229/19, 2x1-47/40, 2x5-37/17
2			Uragan	1865			
3			Tifon	1865			
4			Veshchun	1865			
5			Koldun	1865			
6			Latnik	1865			
7			Edinorog	1865			
8			Strelets	1865			
9			Lava	1865			

CRUISERS

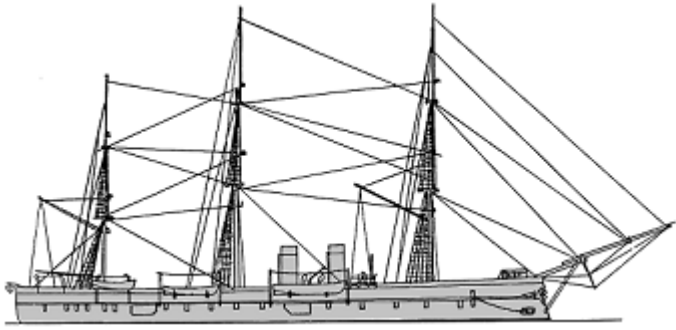
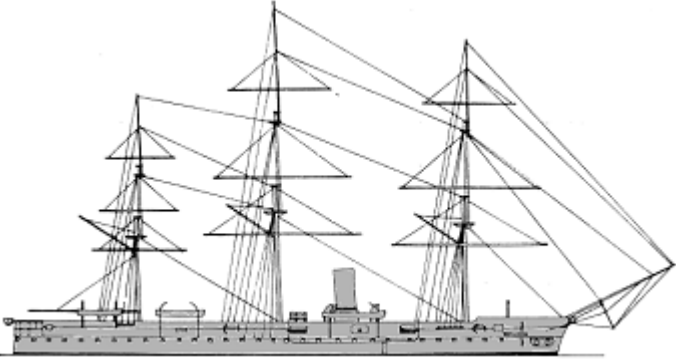
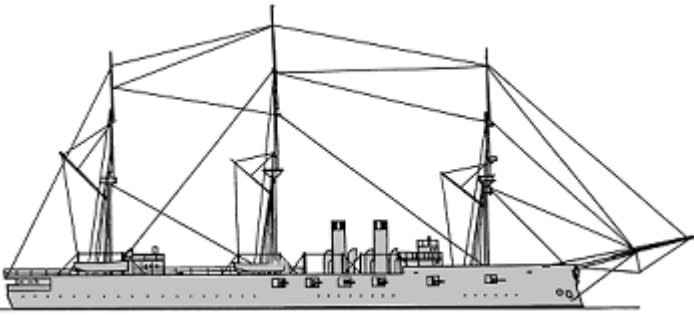
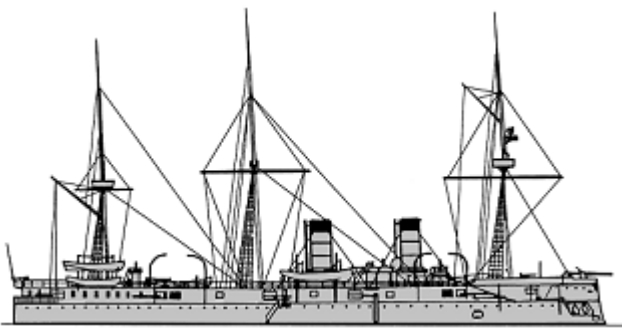
Knyaz Pozharskiy	1	1	Knyaz Pozharskiy	1869		5138t, 83.1x14.9x7.5m, 8b,1hda, 2835hp, 11.7kts, 495p; iron- 102belt, 114battery; 2x1-203/19, 2x1-152/23, 4x1-87/17, 2x1-63/17, 2x1-47/40, 6x5-37/17
General-Admiral	2	2	General-Admiral	1875		5031(2)-4838(3)t, 91.0(2)-86.9(3)x14.6x7.0(2)-7.3(3)m, 5b,1vc(2)-4b,1vc(3), 4470(2)-5222(3)hp, 12.3(2)-13.2(3)kts, 490p; iron- 152belt, 25deck; 4x1-203/28(3), 5x1-152/25(3), 4x1-152/23(2), 6x1-87/21, 6x1-47/40(2), 8x1-37/20(2), 10x5-37/17(3), 1-381TT(2), 3-381TT(3)
		3	Gertsog Edinburgskiy	1877		
Minin	1	4	Minin	1878		6136t, 89.9x15.1x7.7m, 18b,1vte, 4000hp, 12.2kts, 545p; compound- 178belt, 25deck; 4x1-203/28, 6x1-152/44, 4x1-87/17, 6x1-75/48, 2x1-63/17, 8x1-47/40, 2-381TT, 150mines
Vladimir Monomakh	1	5	Vladimir Monomakh	1883		6000t, 93.3x15.9x8.0m, 8b,2vc, 7000hp, 15.2kts, 566p; compound- 152belt, 13deck; 5x1-152/44, 6x1-120/43, 2x1-63/17, 16x1-47/40, 4x1-37/20, 3-381TT
Dmitriy Donskoy	1	6	Dmitriy Donskoy	1885		6200t, 93.4x15.9x7.9m, 8b,1vc, 7000hp, 16.5kts, 571p; compound- 152belt, 13deck; 6x1-152/44, 10x1-120/43, 2x1-63/17, 6x1-47/40, 10x1-37/20, 5-381TT

CA

Admiral
Nakhimov

1 7

Admiral
Nakhimov

1888

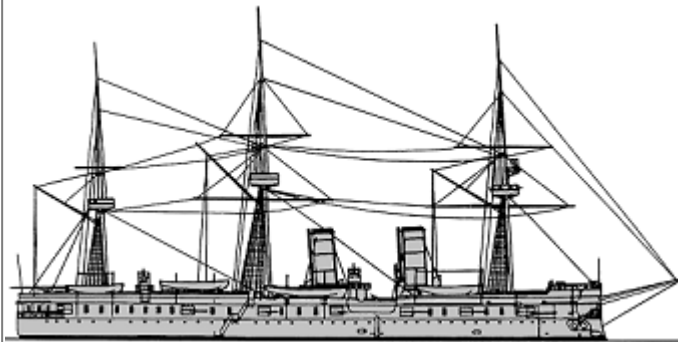

8524t, 103.3x18.6x8.4m, 12b,2vc, 8000hp, 17kts, 570p; compound- 254belt, 76deck, 203barbettes, 152CT; 4x2-203/33, 10x1-152/32, 2x1-63/17, 12x1-47/40, 6x1-37/20, 3-381TT, 40mines

Pamyat
Azova

1 8

Pamyat
Azova

1890

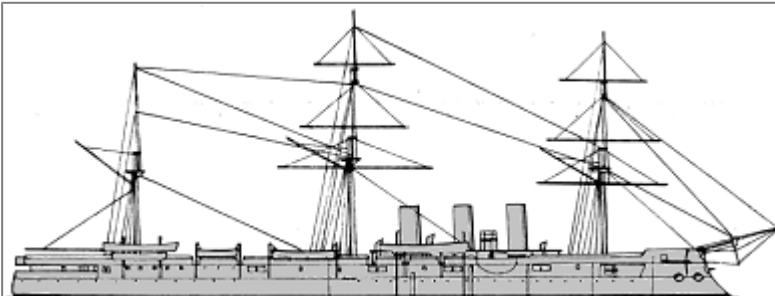

6674t, 117.2x17.2x8.2m, 6b,2vte, 8500hp, 17kts, 640p; compound- 152belt, 63deck, 51shields, 38CT; 2x1-203/33, 13x1-152/32, 2x1-63/17, 7x1-47/40, 8x5-37/17, 3-381TT

Ryurik

1 9

Ryurik

1895

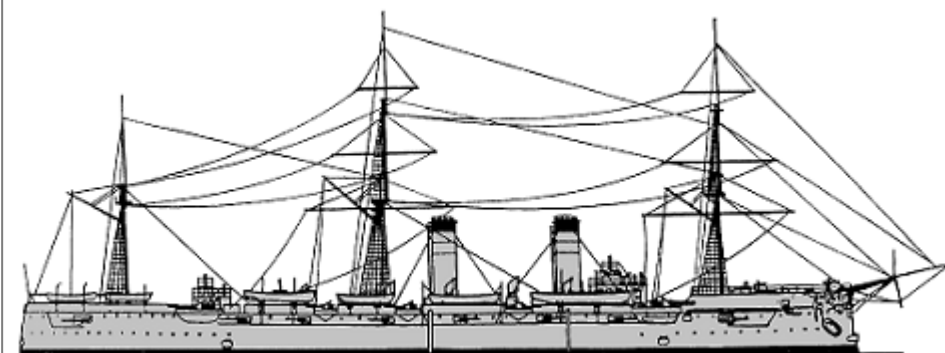

11690t, 132.6x20.4x7.9m, 8b,2vte, 13250hp, 18kts, 683p; steel- 254belt, 76deck, 51shields, 152CT; 4x1-203/33, 16x1-152/44, 6x1-120/43, 2x1-63/17, 10x1-47/40, 12x5-37/17, 6-381TT

Rossiya

1 10

Rossiya

1897

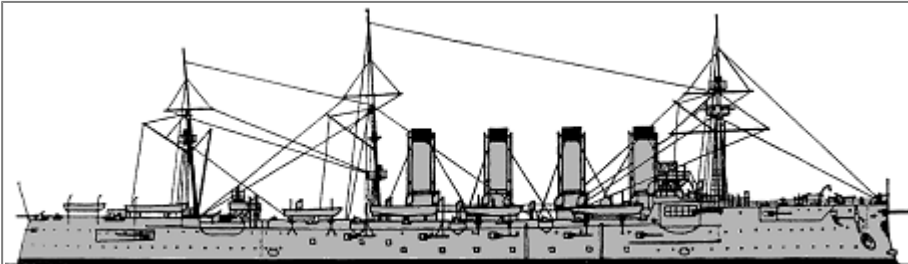



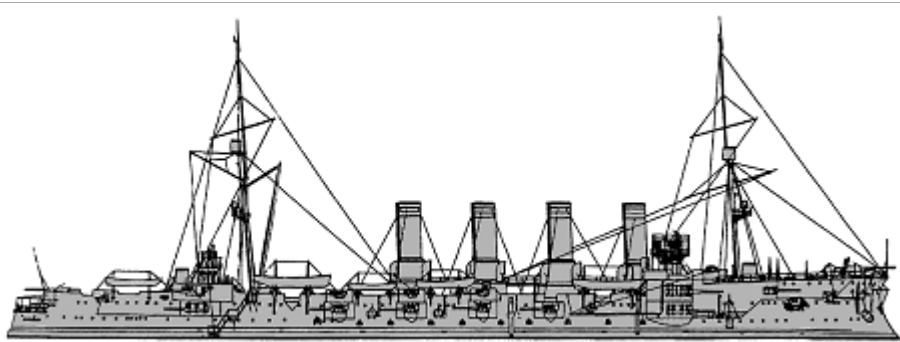
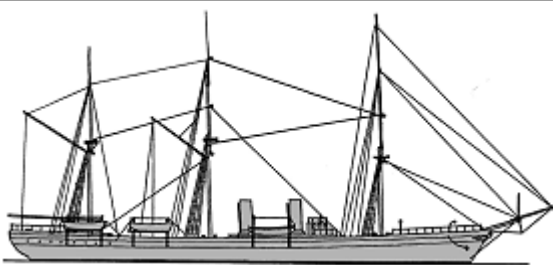
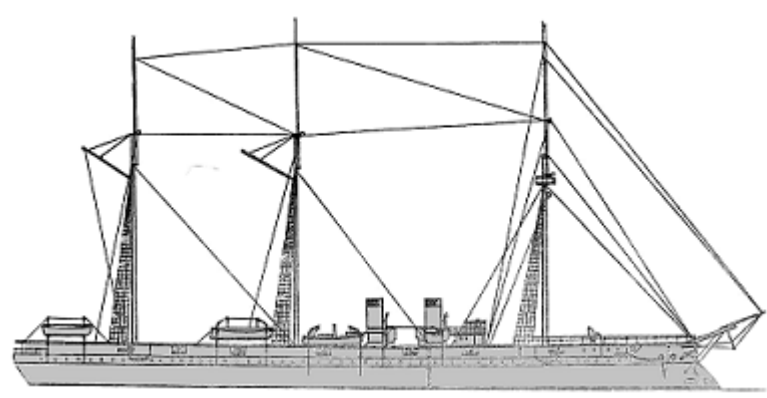
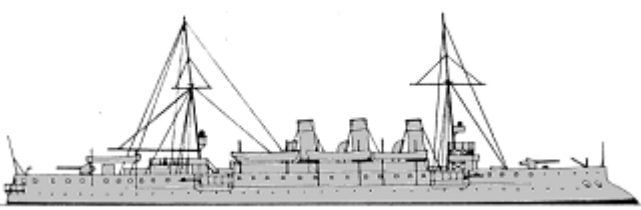
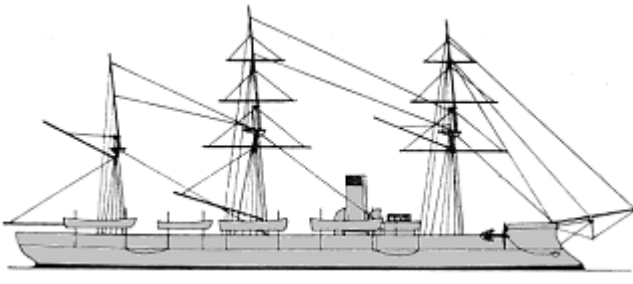

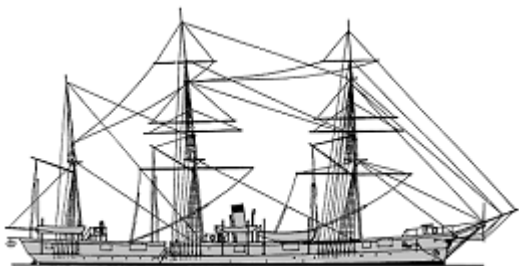
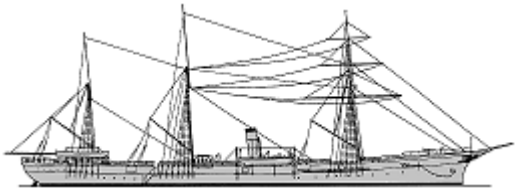
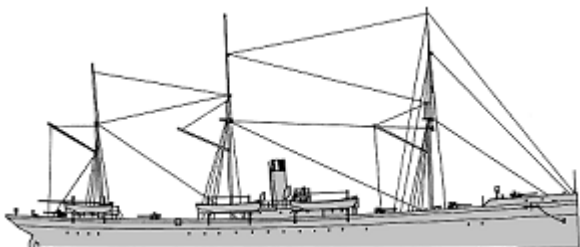



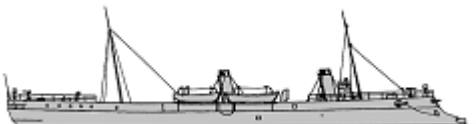
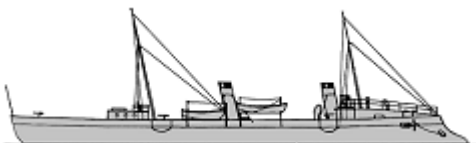

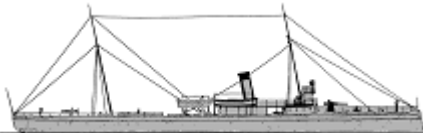











12195t, 147.8x20.9x7.9m, 32b,3vte, 17000hp, 19.7kts, 839p; Harvey- 203belt, 76deck, 127casemates, 305CT; 4x1-203/43, 16x1-152/44, 12x1-75/48, 20x1-47/40, 18x1-37/20, 5-381TT









	Gromoboy	1	11	Gromoboy	1899		12455t, 146.6x20.9x7.9m, 32b,3vte, 14500hp, 19kts, 874p; 152belt, 76deck, 127casemates, 305CT; 4x1-203/43, 16x1-152/44, 24x1-75/48, 12x1-47/40, 18x1-37/20, 4-381TT
CL	Vityaz	1	1	Rynda	1886		3537t, 79.4x13.7x5.3m, 10b,1hc, 3000hp, 11.5kts, 396p; steel- 38deck; 4x1-152/25, 4x1-87/21, 2x1-47/40, 6x5-37/17, 1-381TT
	Admiral Kornilov	1	2	Admiral Kornilov	1888		5880t, 112.2x14.8x7.8m, 8b,2hte, 5977hp, 17.6kts, 479p; steel- 63deck, 76CT; 14x1-152/32, 6x1-47/40, 10x5-37/17, 6-381TT
	Svetlana	1	3	Svetlana	1898		3862t, 101.0x13.0x5.7m, 18b,2vte, 8500hp, 21.6kts, 401p; NS- 63slopes, 38deck, 102CT; 6x1-152/44, 10x1-47/40, 2-381TT, 20mines
CLL	Pamyat Merkuriya	1	1	Pamyat Merkuriya	1880		2997t, 90.0x12.4x6.0m, 6b,1hc, 3000hp, 14kts, 343p; 6x1-152/25, 2x1-63/17, 4x1-47/40, 2x1-37/20, 2x5-37/17, 2-381TT, 180mines
	Kreyser		1	Kreyser	1876		1334-1449t, 70.5x10.0-10.1x5.1m, 4b,1hc, 1383-1786hp, 10-13.5kts, 188-199p; 2x1-152/25(1,2), 1x1-152/25(4,6), 3x1-152/25(5,7,8), 2x1-152/23(3,4,6), 4x1-107/17(1-3), 4x1-87/21(4,6-8), 2x1-87/21(5), 1x1-63/17(1-3,6-8), 2x1-44/41(1,2), 4x1-44/41(3), 4x5-37/17(1,2), 6x5-37/17(3,6-8), 7x5-37/17(4), 1x5-37/21(5), 1-
		2	Dzhigit	1877			
		3	Razboynik	1879			
		4	Naezdnik	1879			
		5	Plastun	1879			

SL							381TT(1,3,5-8), 2-381TT(4)
		6	Strelok	1880			
		7	Vestnik	1881			
		8	Oprichnik	1881			
	Zabiyaka	1	9	Zabiyaka	1879		1236t, 67.0ppx9.1x4.0m, 2b,1vc, 1426hp, 14.2kts, 155p; 2x1-152/25, 4x1-107/17, 1x1-63/17, 4x1-47/40, 6x5-37/17
AMC -		1		Aziya	1874		2449t, 82.0x10.7xm, 1100hp, 15.6kts; 2x1-152/23, 7x1-107/17
		2	2	Afrika	1878		2590t, 90.2x10.9xm, 1417hp, 12.8kts; 5x1-152/23, 4x1-107/17, 2x1-87/21

TORPEDO SHIPS



PGT	Leytenant Ilyin	1	1	Leytenant Ilyin	1887		714t, 72.3x7.4x3.2m, 6b,2vte, 3500hp, 20.8kts, 128p; steel- 19deck; 7x1-47/40, 6x5-47/22, 6x5-37/17, (5+2x1)-381TT
	Kapitan Saken	1	2	Kapitan Saken	1889		742t, 71.6x7.4x3.1m, 6b,2vte, 3000hp, 18.3kts, 102p; steel- 13deck; 6x1-47/40, 4x5-37/17, (1+2x1)-381TT
	Kazarskiy	6	3	Kazarskiy	1890		432t, 60.2x7.4x3.5m, 2b,1vte, 3500hp, 21-22.5kts, 65p; 6x1-47/40, 3x1-37/20, (1+1x1)-381TT
			4	Voevoda	1892		
			5	Posadnik	1892		
			6	Vsadnik	1894		
7			Gaydamak	1894			
8	Griden	1895					
Abrek	1	9	Abrek	1897		675t, 65.5x7.8x3.4m, 4b,2vte, 4500hp, 21.2kts, 88p; 2x1-75/48, 4x1-47/40, (1+1x1)-450TT	
DD	Sokol	1	1	Sokol	1895		240t, 57.9x5.6x2.3m, 8b,2vte, 3800hp, 29kts, 54p; 1x1-75/48, 3x1-47/40, 2x1-381TT



TB	Vzryv	1	1	Vzryv	1877		160t, 39.6x4.9x3.4m, 2b,1vc, 800hp, 13.5kts, 33p; 4x5-37/17, 2-381TT
	Batum	1	2	No251	1880		48t, 30.6x3.7x1.9m, 1b,1vc, 500hp, 15.2kts, 21p; 2x5-37/17, 2-381TT
	Sukhum	1	3	No257	1883		64t, 34.4x3.8x2.0m, 1b,1vc, 704hp, 17.9kts, 16p; 2x5-37/17, 2-381TT
	Poti	1	4	No258	1883		63t, 38.0x3.1x2.0m, 1b,1vc, 575hp, 18.5kts, 18p; 2x5-37/17, 2-381TT
	Gagry	1	5	No254	1884		80t, 36.8x4.1x2.0m, 1b,1vc, 600hp, 17.8kts, 18p; 1x1-37/20, 1x5-37/17, 2-381TT
	Gelendzhik	1	6	No255	1884		75t, 37.4x3.8x2.1m, 1b,1vc, 520hp, 18kts, 16p; 1x1-37/20, 1x5-37/17, 2-381TT
	No1	1	7	No101	1885		68t, 38.8x3.9x1.4m, 1b,2vc, 472hp, 16.5kts, 21p; 2x5-37/17, 2-381TT
	No17	3	8-10	No106, 107, 267	1886-1888		74(8,9)-77(10)t, 38.9x3.5x2.3m, 1b,1vc, 296(8,9)-520(10)hp, 15.8(8,9)-17.5(10)kts, 21p; 4x5-37/17(8,9), 2x5-37/17(10), 2-381TT
	Sveaborg	2	11	No205	1886		96(11)-108(12)t, 46.8x3.4(11)-3.7(12)x2.6(11)-2.5(12)m, 1b,1vte, 737(11)-837(12)hp, 19.2(11)-19.7(12)kts, 21p; 2x5-37/17, 2-381TT
			12	No206	1886		
	Vyborg	1	13	No102	1886		150t, 45.1x5.2x2.1m, 2b,2vc, 1300hp, 20kts, 24p; 2x5-37/17, 2-381TT
	Abo	3	14-16	No108-110	1886		76t, 38.5x4.5x1.9m, 1b,1vc, 640hp, 19.3-20kts, 21p; 4x5-37/17, 2-381TT
	Yalta	6	17-22	No261-266	1886		85-90t, 38.6x4.6x2.0m, 1b,1vte, 900hp, 20-20.8kts, 18p; 2x5-37/17, 2-381TT
	Yanchikhe	2	23, 24	No201, 202	1889		76t, 39.0x4.5x1.9m, 1b,1vc, 970hp, 16.8-17.2kts, 21p; 2x5-37/17, 2-381TT
	Adler	1	25	No259	1890		164t, 46.9x5.1x2.0m, 2b,2vte, 2000hp, 26.7kts, 25p; 2x5-37/17, (1+2x1)-381TT
	Anakriya	1	26	No260	1890		100t, 38.6x4.8x2.1m, 2b,1vte, 1100hp, 21kts, 21p; 2x5-37/17, (1+1x1)-381TT
	Nargen	2	27	No203	1891		153t, 47.3x5.0x2.6m, 2b,2vte, 2039(27)-1956(28)hp, 19.5(27)-20.3(28)kts, 21p; 3x5-37/17, (1+2x1)-381TT
			28	No204	1891		
	Biorke	4	29-32	No111-114	1891-1892		81t, 38.4x4.5x2.6m, 1b,1vte, 1000-1100hp, 17.8-19kts, 21p; 2x5-37/17, 2x1-381TT
	Borgo	2	33	No207	1891		118t, 41.7x4.5x2.6m, 1b,1vte, 1245hp, 20kts, 21p; 2x5-37/17, (1+1x1)-381TT
34			No117	1891			
Anapa	2	35, 36	No252, 253	1891-1892		96t, 38.4x4.5x2.6m, 1b,1vte, 1000-1100hp, 17.2-19kts, 18p; 2x5-37/17, 2x1-381TT	
		37	No118	1892			

Dago	4	38	No256	1892		101-105t, 46.5-46.8x3.9x2.3-2.6m, 1b,1vte, 1000-1030hp, 16.2-19kts, 21p; 2x5-47/22(37), 2x5-37/17(38-40), (1+1x1)-381TT
		39	No123	1892		
		40	No124	1892		
Pernov	1	41	No103	1892		120t, 42.0x4.5x2.1m, 2b,2vte, 2000hp, 26kts, 21p; 2x5-37/17, (1+2x1)-381TT
Tosna	2	42, 43	No115, 116	1893		85-87t, 38.7x4.6x2.0m, 1b,1vte, 1000hp, 20kts, 21p; 2x5-47/22, (1+1x1)-381TT
Aspe	4	44	No121	1895		105t, 38.8x4.8x2.1m, 2b,1vte, 1300hp, 20kts, 21p; 2x5-37/17, (1+1x1)-381TT
		45	No122	1895		
		46	No125	1894		
		47	No126	1894		
Sestroretsk	1	48	No104	1894		80t, 36.8x4.2x2.6m, 1b,1vte, 1300hp, 23kts, 21p; 2x5-37/17, (1+1x1)-381TT
No119	19	49	No119	1895		120t, 42.0x4.5x2.1m, 2b,2vte, 2000hp, 19.5-23.2kts, 21p; 2x5-37/17, (1+2x1)-381TT
		50	No120	1895		
		51	No127	1898		
		52	No128	1898		
		53	No129	1899		
		54	No133	1897		
		55	No134	1897		
		56	No135	1897		
		57	No136	1897		
		58	No137	1897		
		59	No138	1897		
		60	No139	1897		
		61	No140	1897		
		62	No141	1897		
		63	No142	1897		
		64	No270	1897		
		65	No271	1897		
		66	No272	1899		
		67	No273	1899		
No131	3	68	No131	1897		100t, 38.7x5.2x2.0m, 2b,2vte, 1000hp, 21kts, 18p; 2x5-37/17, (1+1x1)-381TT
		69	No132	1896		
		70	No268	1895		
No208	3	71	No208	1899		130t, 42.0x4.5x2.1m, 2b,2vte, 1460hp, 18.5kts, 21p; 2x5-37/17, (1+2x1)-381TT
		72	No209	1899		
		73	No210	1899		
No2	1	1	No88	1874		25t, 22.9x3.1x1.5m, 1b,1hda, 112hp, 14kts; 1x1-381TT

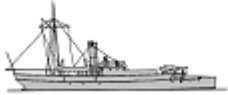
TB2cl	No5	1	2	No89	1877		11t, 19.8x2.6x0.6m, 1b,1vte, 120hp, 16kts, 9p; 1x1-381TT
	Vorona	1	3	No151	1877		23t, 22.9x2.6x1.1m, 1b,1vc, 220hp, 12kts, 11p; 1x1-381TT
	Oryol	70	4-73	No1-12, 15, 17-22, 25-40, 42-73, 95, 97, 143	1877-1878		23t, 21.7x2.7x1.7m, 1b,1vc, 220hp, 16kts, 7p; 1x1-381TT
	Kefal	1	74	No90	1877		13t, 17.4x2.3x0.9m, 1b,1hda, 90hp, 12kts, 9p; 1x1-381TT
	Chizhik	4	75-78	No82, 91-93	1877-1878		23t, 21.7x3.0x1.1m, 1b,1vc, 220hp, 16kts, 9p; 1x1-381TT
	Galka	1	79	No13	1878		34t, 22.1x3.1x1.6m, 1b,1vc, 220hp, 13kts, 9p; 1x1-381TT
	Kasatka	1	80	No14	1878		28t, 21.8x3.0x1.9m, 1b,1vc, 312hp, 13kts, 9p; 1x1-381TT
	Podorozhnik	1	81	No94	1878		20t, 21.5x2.8x0.8m, 1b,1vc, 200hp, 14kts, 9p; 1x1-381TT
	Selezen	1	82	No41	1878		33t, 22.7x3.4x1.8m, 1b,1vc, 200hp, 13kts, 9p; 1x1-381TT
	Mech	4	83-86	No75, 76, 78, 81	1878		20t, 20.1x3.4x1.3m, 1b,1vte, 260hp, 15kts, 9p; 1x1-381TT
	Samopal	2	87, 88	No23, 24	1878		30t, 25.6x3.3x1.9m, 1b,1vc, 250hp, 15kts, 8p; 1x1-381TT
	Shchuka	3	89-90	No83-85	1878		24t, 22.9x3.1x1.4m, 1b,1hda, 220hp, 16kts, 9p; 1x1-381TT
	Skumbriya	2	91, 92	No86, 87	1878		31t, 20.0x3.2x1.1m, 1b,1hda, 220hp, 13.5kts, 9p; 1x1-381TT
	Sirena	1	93	No16	1879		29t, 25.3x3.4x0.9m, 1b,1vc, 220hp, 14.5kts, 9p; 1x1-381TT
	Skorpion	1	94	No96	1879		31t, 19.2x3.1x1.2m, 1b,1hda, 220hp, 14kts, 9p; 1x1-381TT
No46	1	95	No74	1889		15t, 18.2x2.6x1.3m, 1b,1vc, 200hp, 16.5kts; 1x4-25/41, 1x1-381TT	

OTHER FIGHTING SHIPS

Opyt	1	1	Mina	1862	No picture	270t, 37.7x6.8x1.8m, 1b,2hp, 195hp, 9kts, 28p; iron- 114breastwork; 2x1-87/17
Pishchal	1	2	Pishchal	1872	No picture	346t, 40.8x7.7x2.2m, 1b,1hda, 172hp, 8kts, 48p; 6x1-87/17
Yorsh	1	3	Yorsh	1875		321t, 30.1x8.7x2.2m, 2b,2hc, 240hp, 8kts, 44p; 1x1-279/17, 2x1-44/41
Burun	4	4	Burun	1880		424(4-6)-383(7)t, 36.4x8.8x2.4m, 2b,2hc, 240-283hp, 7.5kts, 54p; 1x1-279/18(6), 3x1-107/17(5), 6x1-107/17(7), 4x1-87/21(4), 5x1-87/21(5), 2x1-75/48(7), 3x1-37/20(4), 2x1-37/20(6,7)
		5	Tucha	1880		
		6	Burya	1881		
		7	Groza	1881		
Dozhd	4	8	Dozhd	1880		402(8,10,11)-390(9)t, 33.5x10.5(8,10,11)-11.6(9)x2.2m, 2b,2hc, 300(8,10,11)-445(9)hp, 9-9.3kts, 54p; 1x1-279/17(9,11), 1x1-279/18(10), 6x1-37/20(8), 2x1-37/20(9-11)
		9	Vikhr	1880		
		10	Grad	1881		

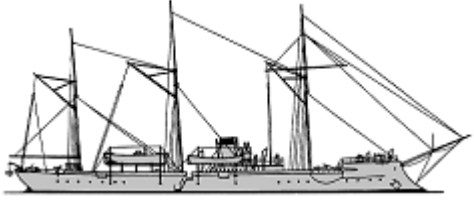
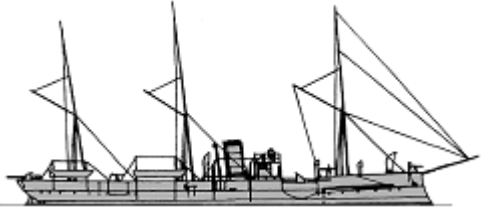
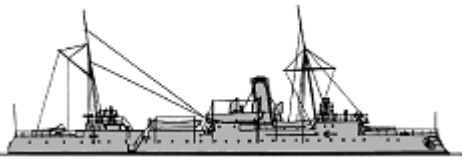
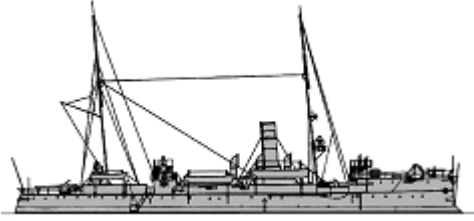
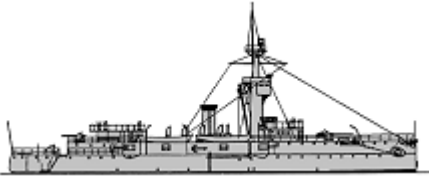
PG							
		11	Sneg	1881			
	Sivuch	2	12	Sivuch	1884		1134(12)-1187(13)t, 60.3x10.7x3.5(12)-3.7(13)m, 6b,2hc, 1100hp, 11kts, 188p; steel- 13deck; 1x1-229/27, 1x1-152/25, 6x1-107/17, 1x1-63/17, 4x5-37/17
			13	Bobr	1886		
	Koreets	2	14	Koreets	1887		1334(14)-1418(15)t, 66.3(14)-66.6(15)x10.7x3.5(14)-3.8(15)m, 6b,2hc, 1500hp, 13kts, 179p; 2x1-203/33, 1x1-152/32, 4x1-107/17, 1x1-63/17, 2x1-47/40, 4x5-37/17, 1-381TT
			15	Mandzhur	1887		
	Kubanets	6	16	Kubanets	1887		1505t, 67.2(16-18)-64.5(19-21)x12.2x3.8m, 6b,2hc(16-18)-6b,2hte(19-21), 1500hp, 11-14kts, 180p; 2x1-203/33, 1x1-152/32, 6x5-47/22, 2-381TT
			17	Terets	1887		
			18	Uralets	1888		
			19	Zaporozhets	1888		
20			Chernomorets	1889			
Grozyashchiy	3	21	Donets	1889			
		22	Grozyashchiy	1892		1627(22)-1700(23)-1854(23)t, 72.3x12.7x4.0(22,23)-4.4(24)m, 6b,2vte, 2050(22,23)-2500(24)hp, 14-14.5kts, 178-188p; steel- 127belt, 38deck, 25CT; 1x1-229/32, 1x1-152/32, 6x1-47/40, 4x5-37/17, 2-381TT, 20mines	
		23	Gremyashchiy	1893			
24	Otvazhny	1893					
Khrabry	1	25	Khrabry	1897		2100t, 72.3x12.7x3.8m, 8b, 2vte, 2100hp, 14kts, 188p; 2x1-203/43, 1x1-152/44, 5x1-47/40, 4x1-37/20, 1-450TT, 20mines	
Gilyak	1	26	Gilyak	1899		1251t, 63.1x11.1x3.3m, 6b,2vte, 1000hp, 12kts, 170p; steel- 13deck; 1x1-120/43, 5x1-75/48, 2x1-63/17, 4x1-47/40, 2x1-37/20, 1-450TT	

MINE WARFARE SHIPS

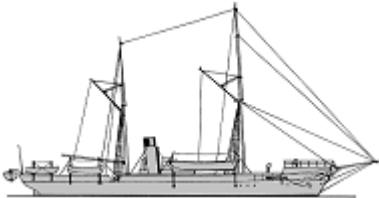
							
	Aleut	1	1	Aleut	1886		892t, 49.4x9.4x3.5m, 2b,1vc, 730hp, 11.9kts, 100p; 4x5-37/17, 250mines

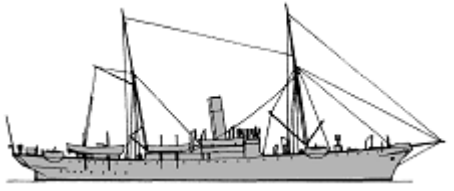
ML	Bug	2	2	Bug	1892		1490t, 62.2x10.4x4.6m, 4b,2vte, 1400hp, 13kts, 226p; 4x1-47/40, 545mines
			3	Dunay	1893		

BOARD GUARD SHIPS

CG	Roksana	1	1	Roksana	1893	No picture	157t, 37.0x4.2x2.0m, 2b,1vte, 600hp, 12kts; 2x5-37/17
	Oryol	1	2	Oryol	1898	No picture	125t, 35.1x5.2x2.4m, 250hp, 12kts, 28p; 2x1-37/20
CB	Gagara	5	1-5	Gagara, Krechet, Lastochka, Lebed, Nyrok	1873	No picture	35t, 21.3x4.0x1.4m, 1vc, 45hp, 10kts, 13p; 1x1-87/17
	Strazh	2	1	Strazh	1874	No picture	230t, 33.0x6.4x2.5m, 1vc, 300hp, 11kts, 36p; 1x1-87/17
			2	Chasovoy	1874		



[home](#)[World navies yesterday](#)[1900](#)

Sarawak 01 January 1900

OTHER FIGHTING SHIPS

PG	Aline	1	1	Aline	1875	No picture	175brt, 43.4x6.5m, 35hp; 2x1-small guns
	Lorna Doone	1	2	Lorna Doone	1881	No picture	118brt, 31.5x5.2m, 40hp, 2x1-small guns
	Aden	1	3	Aden	1884	No picture	300brt, 45.6x7.7m, (sw), 75hp; 1x1-small gun

© Ivan Gogin, 2015

[home](#)[World navies yesterday](#)[1900](#)

Siam 01 January 1900

CRUISERS

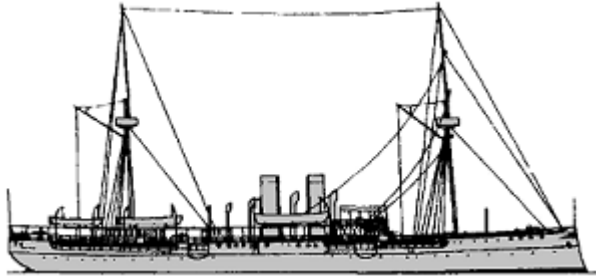
CL	Maha Chakri	1	1	Maha Chakri	1893		2500t, 88.4x12.0x4.2m, 5b,2vte, 3000hp, 15kts, 318p; steel- 51deck; 4x1-120/40, 10x1-57/40
----	-------------	---	---	-------------	------	--	--

TORPEDO SHIPS

TB	Moradoph	1	1	Moradoph	1888	No picture	45t, 22.0x2.8x1.5m, 1b,1hda, 35hp, 10kts; 1spar torpedo
----	----------	---	---	----------	------	------------	---

OTHER FIGHTING SHIPS

PG	Yong Yot	1	1	Yong Yot	1863	No picture	450t, 44.2x6.5x3.4m, 10kts; 6x1-134/14, 1x1-121/22
	Nirben	1	2	Nirben	1866	No picture	290t, 40.6x5.3x2.9m, 9kts; 1x1-102/14, 6x1-small guns
	Han Hak Sakru	1	3	Han Hak Sakru	1866	No picture	260t, 26.8x7.9x2.0m, 7kts; 1x1-102/27
	Maida	1	4	Maida	1867	No picture	370t, 41.8x5.9x3.1m, 11kts; 1x1-121/21
	Kralalahome	1	5	Kralalahome	1867	No picture	278brt, 44.1x6.8m, 60hp
	Phitthayamronnayut	1	6	Phitthayamronnayut	1868	No picture	660t, 50.6x7.9x3.2m, 9kts; 4x1-134/12, 1x1-121/22, 2x1-95/21
	Murathavasitsawat	1	7	Murathavasitsawat	1873	No picture	580t, 45.8x7.6x3.4m, 10kts; 1x1-163/16, 2x1-76/19
	Vara Rattana Phichai	1	8	Vara Rattana Phichai	1875	No picture	450t, 54.3x6.8x2.4m, 10kts
	Ranrukpahairi	1	9	Ranrukpahairi	1879	No picture	450t, 38.4x7.9x3.5m, 540hp, 11kts; 4x1-121/22, 1x1-57/27
	Mongkut Rajakumarn	1	10	Mongkut Rajakumarn	1887	No picture	700t, 53.3x7.2x3.4m, 2b,2vte, 800hp, 14kts, 100p; 2x1-120/40, 4x1-57/40, 3x1-37/20, 1-356TT
	Koh Si Chang	1	11	Koh Si Chang	1890	No picture	100t
	Udhai Rajakich	1	12	Udhai Rajakich	1890	No picture	134t
	Sathit Rajakarn	1	13	Sathit Rajakarn	1892	No picture	
	Theva Sooraram	1	14	Theva Sooraram	1898	No picture	115t
	Muratha	1	15	Muratha	1898		530t, 44.2x7.0x3.1m, 2b,2vte, 500hp, 11.4kts, 83p; 1x1-120/40, 5x1-57/40, 4x1-37/20

							
FB	Siam Mongkut	1	1	Siam Mongkut	1870	No picture	950t, 64.0m; iron- 63battery; 8x1-102/21
DV	Prap Porapak	1	1	Prap Porapak	1898	No picture	210t

© Ivan Gogin, 2015



[home](#)[World navies yesterday](#)[1900](#)

Spain 01 January 1900

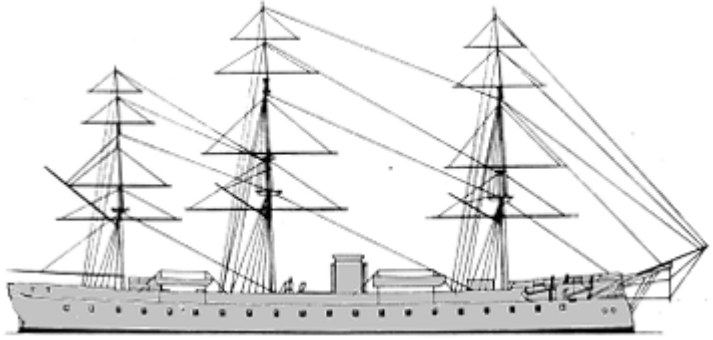
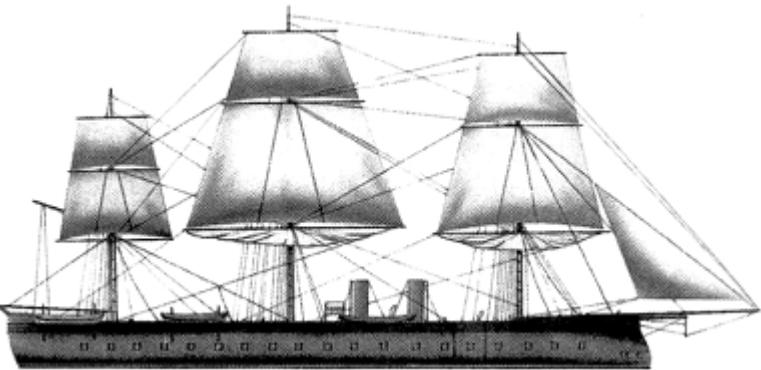
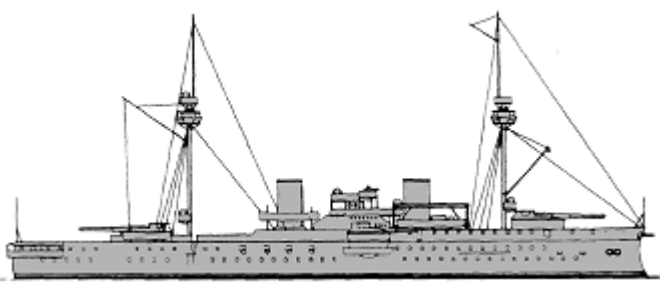
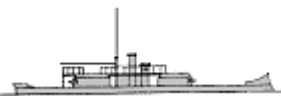
BATTLESHIPS



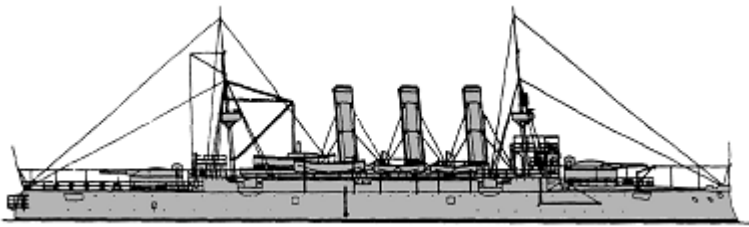

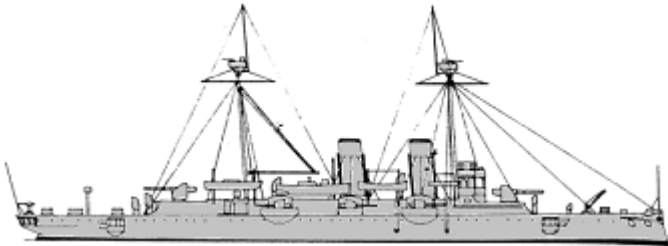
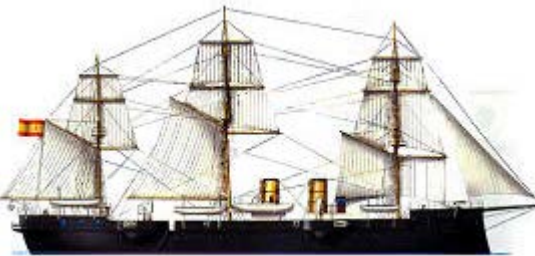
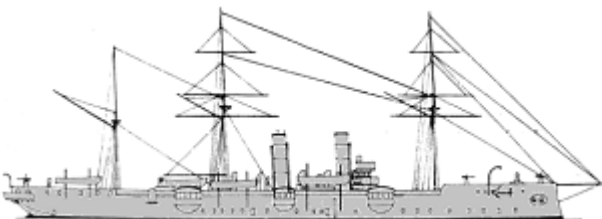





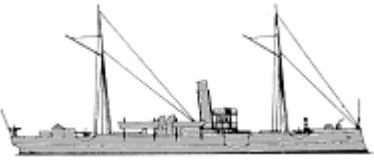

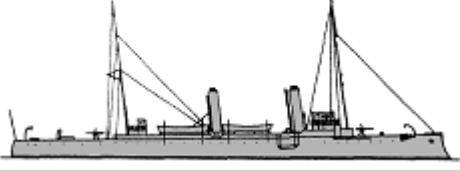

	Numancia	1	1	Numancia	1864		7189t, 96.1x17.4x8.2m, 8b,1hr, 3700hp, 10kts, 500p; iron- 130belt, 120battery; 8x1-254/14, 7x1-203/15, 1x1-200/35
BB	Vitoria	1	2	Vitoria	1867		7135t, 96.4ppx17.4x8.1m, 8b,1hr, 4500hp, 12kts, 500p; iron- 130belt, 120battery; 4x1-254/14, 3x1-203/15, 14x1-200/12
	Pelayo	1	3	Pelayo	1888		9950t, 105.1x20.2x7.6m, 16b,2vc, 9473hp, 16kts, 520p; steel- 450belt, 70deck, 400barbettes, 155CT; 2x1-320/35, 2x1-280/35, 9x1-140/36, 5x1-57/42, 14x1-37/27, 7-381TT
	Duque de Tetuán	1	1	Duque de Tetuán	1874	No picture	703t, 43.0x9.5x2.2m, 190hp, 6kts, 60p; iron- 100side, 100battery; 1x1-160/16, 4x1-121/12
BC	Puigcerdá	1	2	Puigcerdá	1875		552t, 39.0x9.0x2.5m, 328hp, 8kts, 59p; iron- 100belt, 100turrets; 1x1-160/16, 1x2-121/12

CRUISERS

CA	Carlos V	1	1	Carlos V	1897		10100t, 115.8x20.4x7.6m, 12b,2vte, 18500hp, 20kts, 583p; 50belt, 50deck, 250barbettes, 300CT; 2x1-280/35, 8x1-140/36, 4x1-57/42, 2x1-42/43, 4x1-37/27, 6-356TT
CL	Isla de Luzón	1	1	Marqués de la Ensenada	1894		1030t, 60.0x9.1x3.8m, 2b,2hte, 2627hp, 15.9kts, 164p; steel- 64deck, 51CT; 6x1-120/35, 4x1-57/40, 3-356TT
	Reina Regente	2	2	Alfonso XIII	1896		4725t, 97.1x15.2x6.2m, 4b,2hte, 11500hp, 20.4kts, 440p; steel- 120deck, 75shields; 4x1-200/35, 6x1-120/35, 6x1-57/42, 6x1-37/27, 5-356TT
		3	3	Lepanto	1899		
CLL	Aragón	1	1	Aragón	1881		3289t, 71.9x13.4x7.2m, 4400hp, 14kts, 392p; 6x1-160/25(1), 4x1-149/32(2), 2x1-120/27(2), 2x1-87/22, 4x1-75/24, 2-356TT
		2	2	Navarra	1889		
	Velasco	3	3	Infanta Isabel	1888		
		4	4	Isabel II	1888		
5		5	Conde de Venadito	1891			
Alfonso XII	1	6	Alfonso XII	1891		3042t, 84.8x13.2x6.1m, 1hc, 4400hp, 17kts, 370p; 6x1-160/35, 8x1-57/40, 6x5-47/22, 5-356TT	

TORPEDO SHIPS

	Destructor	1	1	Destructor	1887		348t, 58.7x7.6x2.1m, 4b,2vte, 3784hp, 23kts, 45p; steel- 19belt, 19CT; 1x1-87/27, 4x1-57/42, 2x5-37/17, (3+1x2)-356TT
--	------------	---	---	------------	------	--	---

PGT	Temerario	2	Temerario	1891		630t, 58.0ppx6.7x3.2m, 2b,2vte, 2600hp, 19kts, 91p; steel- 13deck; 2x1-120/35, 4x1-57/42, 1x4-25/42, 2x1-356TT	
		3	Nueva España	1891			
		4	Marqués de Molins	1894			
5		Martín Alonzo Pinzón	1893				
6		Vicente Yáñez Pinzón	1894				
	Filipinas	1 7	Filipinas	1895		747t, 70.7x8.2x2.4m, 4b,2vte, 4500hp, 20kts, 110p; 2x1-20/35, 4x1-42/42, (1+3x1)-356TT	
	María de Molina	1 8	María de Molina	1898		830t, 71.6ppx8.0x2.7m, 4b,2vte, 3500hp, 19.5kts, 91p; 152CT; 2x1-120/35, 4x1-42/42, (1+2x1)-356TT	
DD	Furor	1 1	Terror	1896		450t, 67.1ppx6.7x1.7m, 4b,2vte, 6000hp, 28kts, 67p; 2x1-75/42, 2x1-57/42, 2x1-37/27, 2x1-356TT	
	Audaz	2	Audaz	1898		430(2,3)-457(4)t, 69.8x6.9x1.8m, 4b,2vte, 7500hp, 30kts, 67p; 2x1-75/42, 2x1-57/42, 2x1-37/27, 2x1-356TT	
		3	Osado	1898			
4		Proserpina	1898				
TB	Cástor	1 1	Cástor	1878		23t, 23.2x3.0x0.7m, 1b,1vc, 265hp, 19kts, 14p; 1x5-47/22, 1spar torpedo	
	Rigel	1 2	Rigel	1883		57t, 32.0x3.7x1.0m, 1b,1vc, 800hp, 19kts, 18p; 1x5-37/17, 2-356TT	
	Acevedo	2 3, 4	Acevedo, Julián Ordóñez	1885		65t, 36.5x3.8x1.7m, 1b,1vc, 660hp, 20.5kts, 17p; 2x5-25/42, 2-356TT	
	Retamosa	1 5	Retamosa	1886		70t, 36.6x3.8x1.6m, 1b,1vte, 700hp, 20kts, 17p; 2x5-25/42, 2-356TT	
	Orión	1 6	Orión	1886		88t, 38.0x4.8x2.0m, 1b,1vc, 1000hp, 21kts, 18p; 2x5-25/42, 2-356TT	
	Barceló	2 7, 8	Barceló, Bustamante	1886-1887		65t, 38.0x3.1x2.2m, 1b,1vc, 800hp, 20kts, 17p; 2x1-47/40(8), 2x5-25/42(7), 2-356TT	
	Habana	1 9	Habana	1887		67t, 38.9x3.8x1.6m, 1b,1vc, 730hp, 24.5kts, 17p; 1x5-25/42, 2-356TT	
	Azor	2	10	Azor	1887		108t, 41.1x4.2x2.1m, 1b,1vc, 1300hp, 24kts, 23p; 3x1-42/42, 2-356TT
			11	Halcón	1887		
	Ariete	2	12	Ariete	1887		120t, 45.0x4.5x1.5m, 2b,2vc, 1300hp, 26.2kts, 18p; 2x1-42/42, 2x1-25/42, 2-356TT
			13	Rayo	1887		
Ejército	1 14	Ejército	1888	No picture	60t, 34.0x4.0x1.0m, 1b,1vc, 600hp, 18kts, 20p; 1x5-37/17, 2-356TT		
Vedette	3 15-	No1-3	1892	No picture	18.3x2.8m, 1b,1vc, 18.3kts, 13p		

SUBMARINES

SS	Peral	1	1	Peral	1890	No picture	/87t, 21.3x2.6m, 2em, 60hp, /10kts, 6p, 50m; 1-356TT
----	-------	---	---	-------	------	------------	--

OTHER FIGHTING SHIPS



PG	Somorrostro	3	1-3	Bidasoa, Toledo, Segura	1875	No picture	86t, 24.0x4.9x1.9m, 1b,1hse, 80hp, 9kts, 22p; 1x2-121/14
	Pilar	1	4	Pilar	1881	No picture	255t, 35.2x6.6x2.5m, 1b,1vc, 260hp, 8.5kts, 49p; 1x1-120/25, 1x1-87/22
	General Concha	2	5	General Concha	1885	No picture	620t, 50.4x7.9x3.4m, 2b,2vc, 600hp, 11kts, 98p; 3x1-120/25, 2x4-25/42
			6	Magallanes	1887		
	Mac-Mahón	1	7	Mac-Mahón	1888	No picture	115t, 27.6x4.9x1.8m, 2b,2vte, 150hp, 9kts, 15p; 2x1-42/42, 1x5-37/17
	Hernan Cortés	2	8	Hernan Cortés	1895	No picture	295t, 47.4x6.6x1.9m, 1b,1vte, 352hp, 13kts, 53p; 2x1-75/42, 2x1-57/42
			9	Vasco Núñez de Balboa	1895		
Ponce de Leon	1	10	Ponce de Leon	1896	No picture	200t, 41.4x5.8x1.8m, 2b,2vte, 230hp, 12kts, 38p; 2x1-57/42	
PR	Tarifa	1	1	Tarifa	1879	No picture	85t, 35.2x6.7x2.0m, 80hp, 8kts; 1x1-87/22
	Cóndor	3	2-4	Cóndor, Cuervo, Águila	1888-1892	No picture	71t, 24.5x3.9x1.8m, 300hp, 13kts, 27p; 1x1-87/27
	Perla	1	5	Perla	1889	No picture	42t, 19.0x3.6x1.8m, 110hp, 7kts, 26p; 1x2-25/42
	Alerta	1	6	Alerta	1895	No picture	43t, 21.3x2.7x1.3m, 200hp, 10.5kts, 13p; 1x1-42/42, 1x1-37/27

© Ivan Gogin, 2014

[home](#)[World navies yesterday](#)[1900](#)

Sweden 01 January 1900

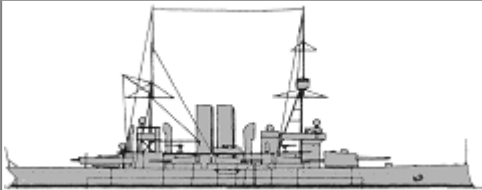
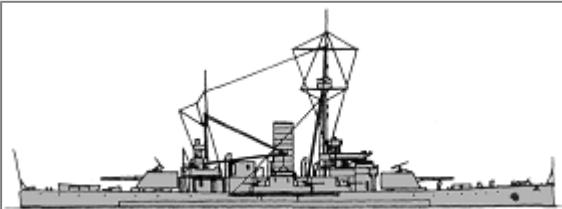
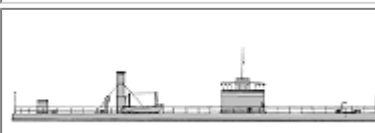

BATTLESHIPS







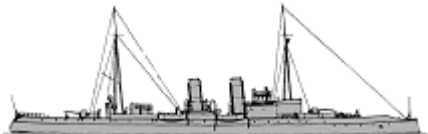

BC	Svea	3	1	Svea	1886		3273(1)-3300(2,3)t, 75.7(1)-78.8(2)-79.5(3)x14.8(1)-14.6(2,3)-5.1m, 6b,2vc, 3640(1)-4700(2,3)hp, 14.7(1)-16(2,3)kts, 252p; compound(1)-steel(2,3)- 297(1)-293(2,3)belt, 49deck, 297(1)-293(2,3)turret; 1x2-254/31, 4x1-152/30(2,3), 4x1-120/43(1), 2x1-57/48(1), 5x1-57/48(2), 5x1-57/46(3), 1x2-37/34(1), 4x1-25/57(2,3), 4x4-25/32(1), 6x4-25/32(2), 4x4-25/32(3), 1x1-12/75(1), 2-450TT(3), 1-381TT(1), 3-381TT(2)		
			2	Göta	1891				
			3	Thule	1893				
	Oden	3	4	Oden	1897				3715(4)-3720(5,6)t, 86.3x14.8x5.3m, 6b,2vte, 5350hp, 16.5kts, 254p; steel(4)-Harvey(5,6)- 243(4)-240(5,6)belt, 49deck, 200(4)-190(5,6)turrets, 247(4)-190(5,6)CT; 2x1-254/41, 4x1-120/43(4), 6x1-120/43(5,6), 10x1-57/52(5,6), 4x1-57/26(4), 6x1-47/49(4), 2x1-25/32(4), 2x2-25/32(5,6), 1-450TT
			5	Thor	1899				
			6	Njord	1899				
MON	John Ericsson	3	1	John Ericsson	1865		1476t, 60.8x13.8x3.7m, 2b,1vde, 380hp, 7kts, 80p; iron- 125(1)-118(2,3)belt, 48(1)-25(2,3)deck, 270(1)-261(2,3)turret, 250(1)-237(2,3)CT; 1x2-274/16(2,3), 2x1-152/30(1), 2x1-57/46(1), 2x5-12/75(2,3)		
			2	Thordön	1866				
			3	Tirfing	1867				
	Loke	1	4	Loke	1871				1574t, 64.0x14.0x3.6m, 2b,1vde, 430hp, 8.5kts, 80p; iron- 125belt, 25deck, 447turret, 237CT; 1x2-240/16

CRUISERS



CL	Balder	1	1	Balder	1871	No picture	1886t, 61.8x11.1x5.6m, 1hrccr, 1380hp, 12kts, 218p; 1x1-152/30, 8x1-122/23, 1x1-65/16, 2x1-37/34
	Saga	1	2	Saga	1878	No picture	1617t, 61.0x10.2x5.6m, 1, 900hp, 11kts, 188p; 1x1-152/25, 8x1-122/20, 1x1-65/16
	Freja	1	3	Freja	1886	No picture	2000t, 66.0ppx12.0x5.7m, 1, 1750hp, 12kts, 284p; 4x1-152/25, 8x1-122/23, 2x1-65/16, 4x1-37/34

TORPEDO SHIPS

PGT	Ören	3	1	Ören	1897		844(1)-846(2)-835(3)t, 67.7x8.2x3.1m, 8b,2vte, 4000hp, 20kts, 113p; 2x1-120/43, 4x1-57/50, 1-381TT
			2	Claes Horn	1898		
			3	Jacob Bagge	1898		
	Hugin	1	1	Hugin	1884		64t, 34.5x3.8x2.0m, 1b,1vc, 620hp, 18.5kts; 1x1-25/32, 2-381TT

TB 1cl	Munin	3	2-4	Munin, Freke, Gere	1887		66t, 34.8x3.8x2.0m, 1b,1vc, 620hp, 18.5kts; 1x1-25/57, 2-381TT
	Gondul	2	5, 6	Gondul, Gudur	1894		86t, 38.6x4.3x2.1m, 1b,1vc, 850hp, 19.5kts, 18p; 2x1-25/57, (1+1x1)-381TT
	Komet	4	7	Komet	1896		120t, 39.8x4.8x2.5m, 1b,1vc, 1300hp, 23kts, 18p; 2x1-37/37, (1+1x1)-381TT
			8	Blixt	1898		
			9	Meteor	1899		
10			Stjerna	1899			
TB2cl	Rolf	1	1	Blink	1882		38t, 27.9xxm, 1b,1vc, 350hp, 16kts; 1x1-25/32, 2-356TT
	Blixt	2	2, 3	Blixt, Galdr	1883-1885		43t, 30.5xxm, 1b,1vc, 420hp, 19kts; 1x1-25/32, 2-356TT
	Narf	2	4, 5	Narf, Nörve	1886		45t, 30.5x3.6x1.9m, 1b,1vc, 440hp, 19.5kts; 1x1-25/32, 2-356TT
	Bygve	2	6, 7	Bygve, Bylgia	1887		57t, 31.5x3.6x1.9m, 1b,1vc, 460hp, 18.5kts; 1x1-25/58, 2-381TT
	Agne	2	8, 9	Agne, Agda	1891-1892		55t, 30.6x3.6x1.9m, 1b,1vc, 460hp, 18.9kts; 1x1-25/58, (1+1x1)-381TT

OTHER FIGHTING SHIPS

MONL	Sköld	2	1	Sköld	1871		262t, 32.7x6.9x2.2m, 1b,1hc, 17hp, 3.7kts, 42p; iron- 25side, 229turret; 1x1-240/16, 2x1-12/75
			2	Fenris	1872		
	Gerda	2	3	Gerda	1872		459t, 39.7x8.0x2.5m, 2b,2hc, 133hp, 7.6kts, 42p; iron- 76belt, 418turret; 1x1-240/18, 2x1-25/32
			4	Hildur	1872		
	Ulf	5	5	Ulf	1873		460t, 39.8x8.0x2.5m, 2b,2hc, 155hp, 8kts, 42p; iron- 76belt, 418turret; 1x1-240/18, 2x1-25/32
			6	Björn	1874		
			7	Berserk	1874		
			8	Sölve	1875		
			9	Folke	1875		
PG	Astrid	2	1	Sigrid	1862	No picture	204t, 32.0x6.3x2.2m, 1, 130hp, 9kts, 39p; iron- 20deck; 2x1-204/12
			2	Alfhild	1863		
	Blenda	2	3	Blenda	1875	No picture	550t, 51.1x8.1x3.0m, 2b,2hc, 590hp, 11.5kts, 71p; 51CT(4); 1x1-274/17(3), 1x1-152/25(4), 1x1-122/23(3), 2x1-57/50(4)
			4	Disa	1877		
	Urd	6	5	Urd	1877	No picture	550t, 53.6x8.1x2.8m, 2b,2hc, 780hp, 72p; 51CT(5,7); 1x1-274/17(6,8-10), 1x1-152/30(5,7), 1x1-122/23(6,8-10), 1x1-120/43(5,7), 2x1-57/50(5,7,10), 2x1-25/32(6,8-10)
			6	Verdande	1880		
			7	Skagul	1878		
			8	Skuld	1881		
			9	Skäggard	1879		
			10	Rota	1878		
Edda	1	11	Edda	1885	No picture	640t, 55.8x8.3x3.1m, 2b,2vc, 960hp, 13.5kts, 76p; 1x1-274/23, 1x1-152/25, 2x1-25/32	
Svenskund	1	12	Svenskund	1891	No picture	280t, 38.5x7.9x3.0m, 440hp, 12.5kts; 2x1-57/50, mines	

MINE WARFARE SHIPS

ML	Ångkranpramen N:r3		1	1	Ångkranpramen N:r3	1879	No picture	190t, 6.5kts; mines
----	--------------------	--	---	---	--------------------	------	------------	---------------------



© Ivan Gogin, 2014

[home](#)[World navies yesterday](#)[1900](#)

United Kingdom 01 January 1900

BATTLESHIPS

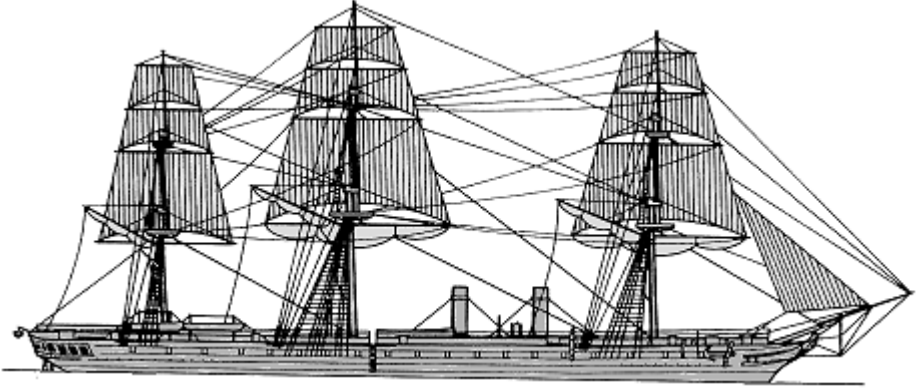
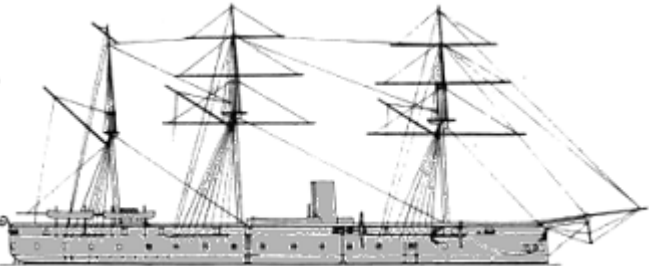
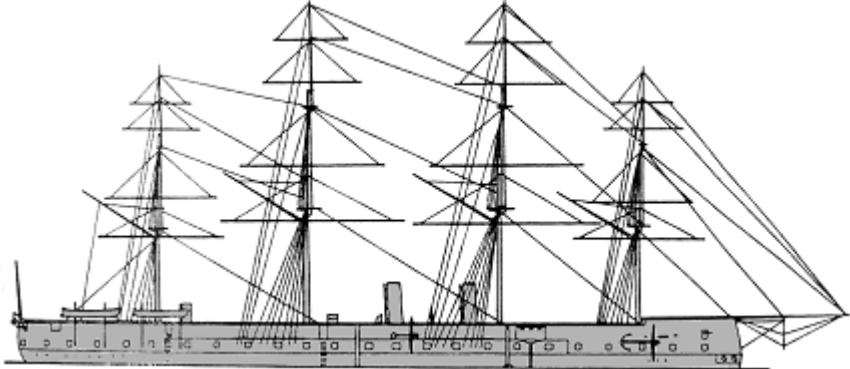
Warrior	1	1	Warrior	1861		9137t, 128.0x17.8x7.9m, 10b,1hset, 5267hp, 14.1kts, 635p; iron: 114belt; 4x1-203/15MLR, 28x1-178/16MLR, 4x1-95/21
Hector	1	2	Hector	1864		6710t, 92.0x17.1x7.6m, 6b,1hrer, 3260hp, 12.6kts, 530p; iron: 114belt, 114battery; 2x1-203/15MLR, 16x1-178/16MLR
Achilles	1	3	Achilles	1864		9820t, 115.8ppx17.8x8.3m, 10b,1hset, 5720hp, 14.3kts, 705p; iron: 114belt, 114battery; 14x1-229/14MLR, 2x1-152/26, 8x1-47/40, 16x1-11.4, 6-356TC
Bellerophon	1	4	Bellerophon	1866		7551t, 91.4x17.1x7.5m, 8b,1hset, 6521hp, 14.2kts, 650p; iron: 152belt, 152battery, 203CT; 10x1-203/26, 4x1-152/26, 6x1-102/25, 4x1-57/40, 12x1-11.4, 2-406TC

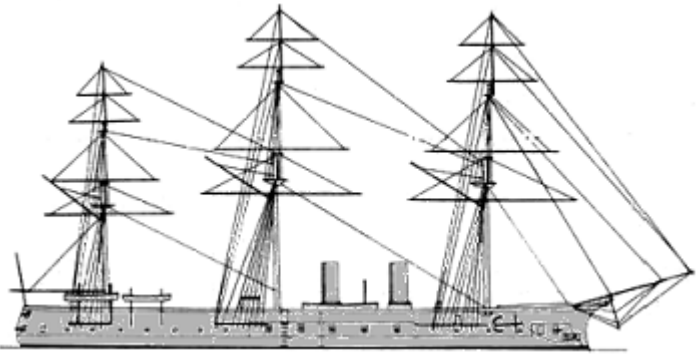
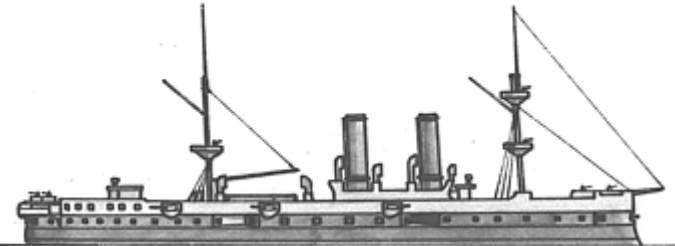
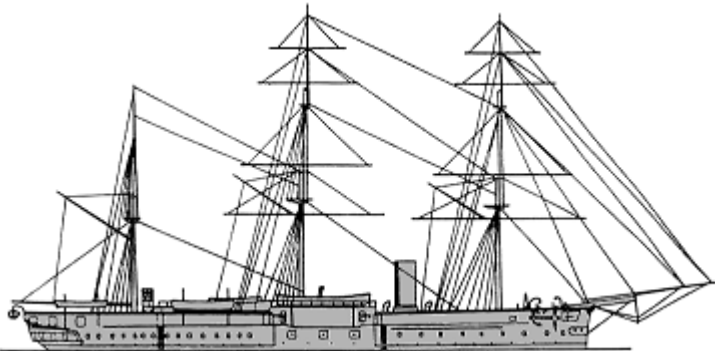
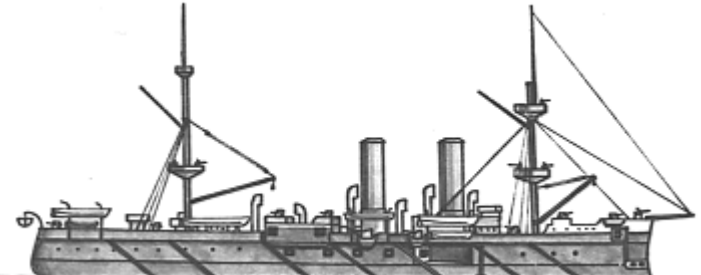
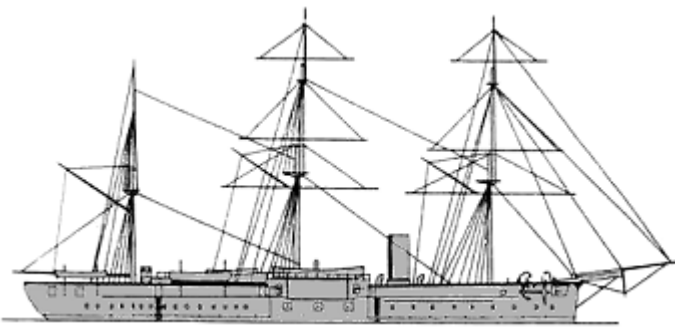
					
Hercules	1 5	Hercules	1868		8830t, 99.1ppx18.0x7.7m, 8b,1ite, 8530hp, 15.9kts, 638p; iron: 229belt, 203battery; 8x1-254/15MLR, 2x1-229/14MLR, 3x1-178/16MLR, 2x1-152/40, 8x1-148/11, 6x1-120/40, 9x1-57/40, 13x1-47/40, 4-356TC
Audacious	6	Audacious	1870		6010t, 85.3ppx16.5x6.9m, 6b,2hr, 4020-4830hp, 12.6-14.1kts, 450p; iron: 203belt, 152battery; 10x1-229/14MLR, 4x1-127/25(8), 8x1-102/27(6), 6x1-102/27(7), 6x1-95/21, 4x1-57/40(6), 6x1-47/40(6), 4-356TC
	7	Invincible	1870		
	8	Iron Duke	1871		
Sultan	1 9	Sultan	1871		9540t, 99.1ppx18.0x8.1m, 8b,1vte, 8244hp, 15.3kts, 633p; iron: 229belt, 229battery; 8x1-254/15MLR, 4x1-229/14MLR, 4x1-120/40, 7x1-95/21, 4x1-57/40, 4-356TC, 2 TBs
Swiftsure	10	Swiftsure	1872		6640-6910t, 85.3x16.8x7.6m, 6b,1hr, 4890-4910hp, 13.7-14.1kts, 450p; iron: 203belt, 152battery; 10x1-229/14MLR, 4x1-127/25(11), 8x1-102/27(10), 6x1-95/21, 8x1-57/40, 8x1-47/40, 4-356TC
	11	Triumph	1873		
	12	Devastation	1873		

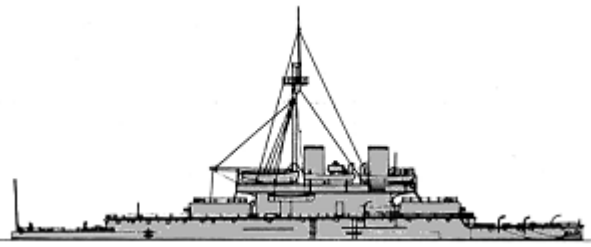
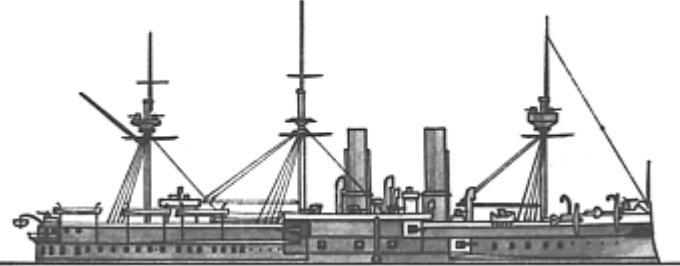
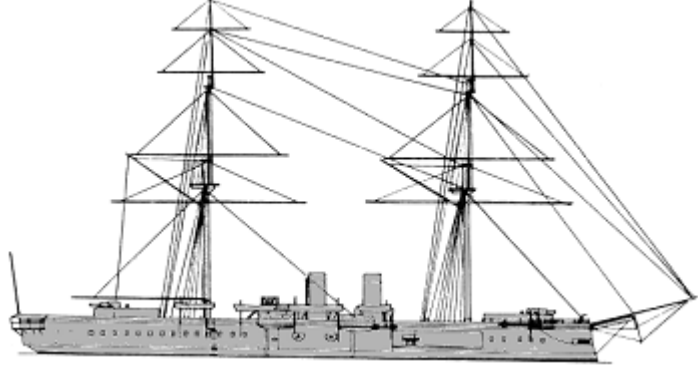
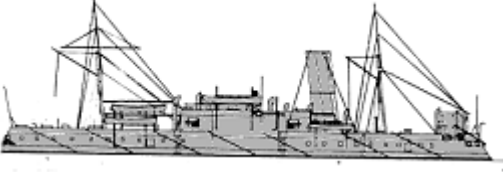
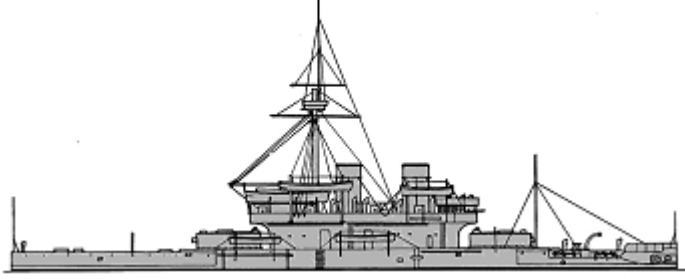
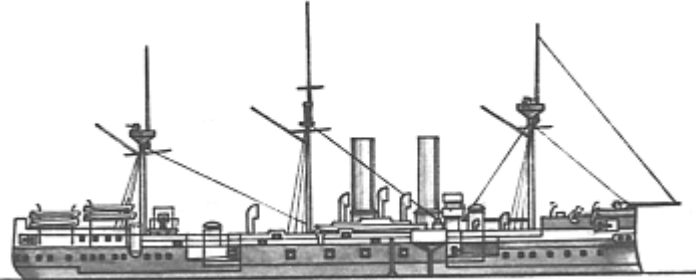
Devastation	2	13	Thunderer	1877		9387-9390t, 93.6x19.0x8.0m, 8b,2vte, 7000hp, 14kts, 358p; iron: 305belt, 76deck, 356turrets, 229CT; 2x2-254/32, 6x1-57/40, 8x1-47/40, 8x1-25/60, 2-356TT
Alexandra	1	14	Alexandra	1877		9492t, 104.9x19.5x8.0m, 12b,2vic, 8498hp, 15.1kts, 674p; iron: 305belt, 38deck, 305battery, 305CT; 8x1-254/15MLR, 4x1-234/32, 6x1-120/40, 6x1-57/40, 12x1-47/40, 4-356TC
Temeraire	1	15	Temeraire	1877		8540t, 86.9ppx18.9x8.2m, 12b,2vic, 7697hp, 14.7kts, 580p; iron: 279belt, 38deck, 254barbettes; 4x1-279/12MLR, 4x1-254/15MLR, 6x1-102/27, 4x1-57/40, 10x1-47/40, 2-356TC
Belleisle	2	16	Belleisle	1878		4870t, 74.7ppx15.9x6.4m, 4b,2hdase, 4040hp, 13kts, 250p; iron: 305belt, 76deck, 267battery, 229CT; 4x1-305/14MLR, 4x1-95/21, 6x1-47/40, 2-356TC
		17	Orion	1882		
Dreadnought	1	18	Dreadnought	1879		10886t, 104.6x19.5x8.1m, 12b,2vce, 8206hp, 14.5kts, 369p; iron: 356belt, 76deck, 356turrets, 356CT; 2x2-318/16MLR, 6x1-57/40, 10x1-47/40, 2-356TT
Superb	1	19	Superb	1880		9710t, 101.3ppx18.0x7.8m, 5b,2hte, 8500hp, 14.5kts, 654p; iron: 305belt, 38deck, 305battery, 203CT; 12x1-254/15MLR, 10x1-152/40, 6x1-57/40, 10x1-47/40, 4-356TC

BB

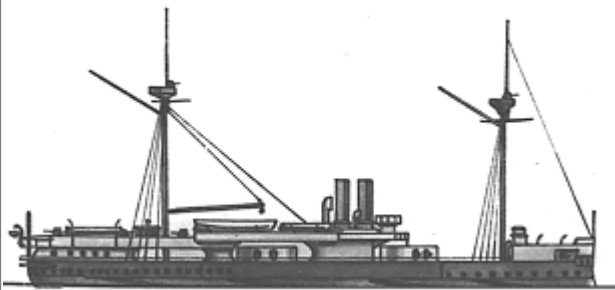
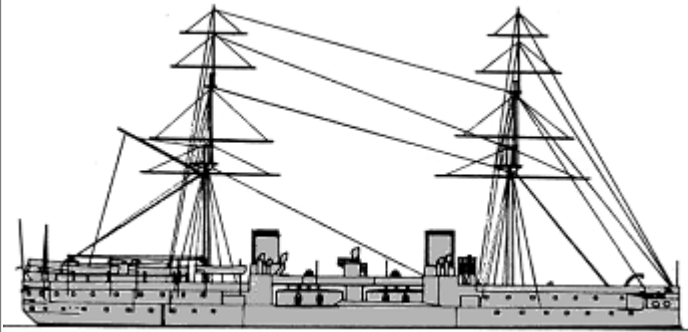
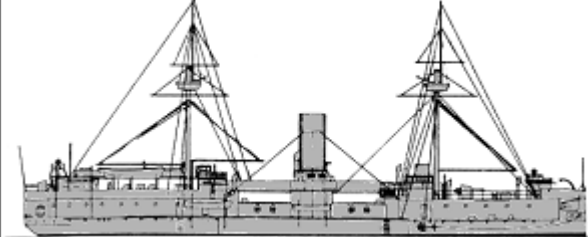
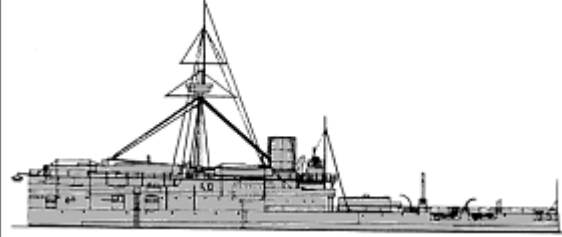
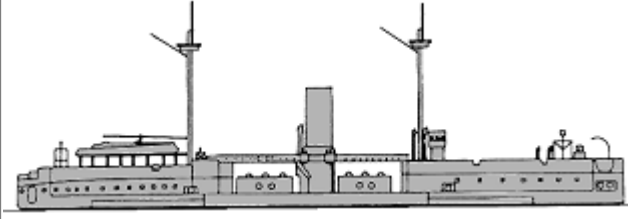
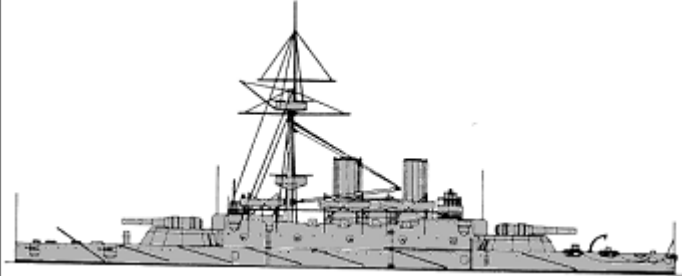
Neptune	1	20	Neptune	1881		9130t, 91.4ppx19.2x7.6m, 8b,1hset, 7993hp, 14.2kts, 541p; iron: 305belt, 76deck, 330turrets, 203CT; 2x2-305/12MLR, 2x1-229/14MLR, 6x1-95/21, 6x1-57/40, 8x1-47/40, 2-356TC
Inflexible	1	21	Inflexible	1881		11880t, 104.9x22.9x7.8m, 12b,2ice, 8488hp, 14.7kts, 440p; iron: 610belt, 76deck, 432turrets(compound), 305CT; 2x2-406/18MLR, 8x1-120/40, 4x1-57/40, 2x1-47/40, (2+2)-356TT/TC
Agamemnon	2	22	Agamemnon	1883		8510t, 91.7x20.1x7.2m, 10b,2ice, 6000hp, 13kts, 345p; iron: 457belt, 76deck, 406turrets(compound), 305CT; 2x2-318/16MLR, 2x1-152/26, 6x1-57/43, 8x1-47/40, 2-356TC
		23	Ajax	1883		
Conqueror	2	24	Comqueror	1886		6200-6440t, 87.8x17.7x7.2m, 8b,2ice, 6000hp, 15.5kts, 330p; compound: 305belt, 64deck, 356turret, 305CT; 1x2-305/25, 4x1-152/26, 7x1-57/40, 5x1-47/40, 6-356TC
		25	Hero	1888		
Colossus	2	26	Edinburgh	1887		9420t, 99.1ppx20.7x7.9m, 10b,2ice, 6808(26)-7488(27)hp, 16(26)-16.5(27)kts, 396p; compound: 457belt, 76deck, 406turrets, 356CT; 2x2-305/25, 5x1-152/27, 4x1-57/40, 10x1-47/40, 2-356TT
		27	Colossus	1885		
Collingwood	1	28	Collingwood	1887		9500t, 99.1ppx20.7x8.0m, 12b,2ice, 9600hp, 16.8kts, 498pp; compound: 457belt, 76deck, 229barbettes, 305CT: 2x2-305/25, 6x1-152/27, 12x1-57/40, 8x1-47/40, 4-356TT
		29	Rodney	1888		

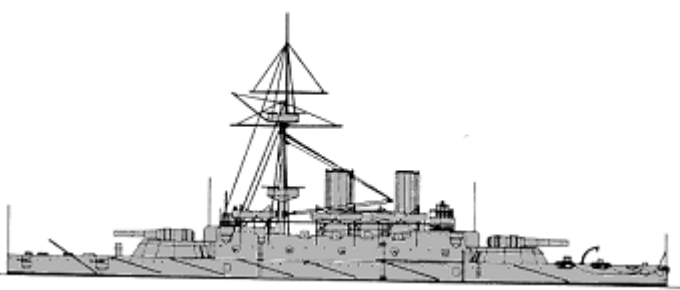
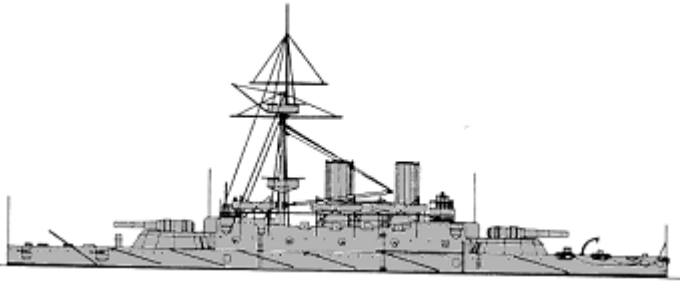
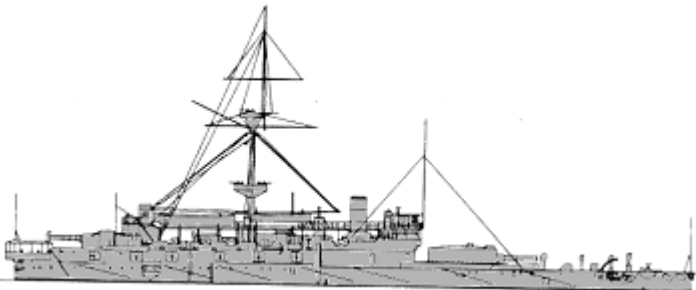
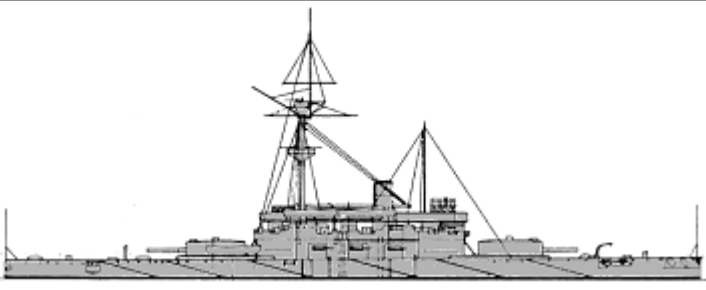
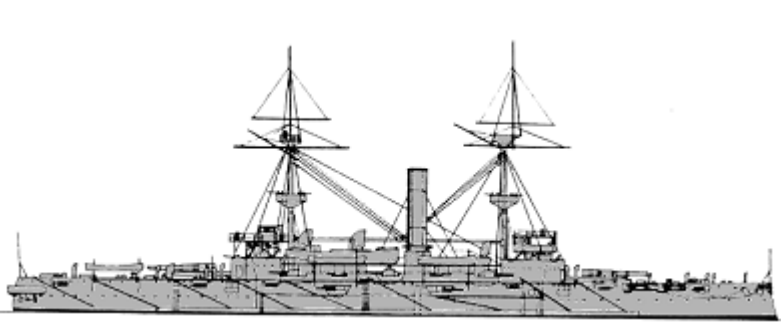
Rodney	4	30	Howe	1889		10300(29,30)-10600(31,32)t, 99.1pp(29,30)-100.6pp(31,32)x20.7(29,30)-20.9(31,32)x8.5m, 12b,3ice, 11500hp, 17(29,30)-17.4(31,32)kts, 530p; compound: 457belt, 76decks, 292(29,30)-356(31,32)barbettes, 305CT; 2x2-343/30, 6x1-152/27, 12x1-57/40, 10x1-47/40, 5-356TT
		31	Camperdown	1889		
		32	Anson	1889		
Benbow	1	33	Benbow	1888		10600t, 100.6ppx20.9x8.5m, 12b,2ice, 10860hp, 17.5kts, 523p; compound: 457belt, 76deck, 356barbettes, 305CT; 2x1-413/30, 10x1-152/27, 12x1-157/40, 7x1-47/40, 5-356TT
Victoria	1	34	Sans Pareil	1891		10470t, 110.6x21.3x8.2m, 8b,2vte, 14482hp, 17.7kts, 430p; compound: 457belt, 76deck, 432turret, 356CT; 1x2-413/30, 1x1-254/32, 12x1-152/27, 12x1-57/40, 9x1-47/40, (4+2)-356TT/TC
Trafalgar	2	35	Trafalgar	1890		12590t, 105.2ppx22.3x8.7m, 6b,2vte, 12000hp, 16.7kts, 577p; compound: 508belt, 76deck, 457turret, 356CT; 2x2-343/30, 6x1-152/40, 8x1-57/40, 9x1-47/40, 4- 356TT
		36	Nile	1891		
Royal Sovereign	7	37	Royal Sovereign	1892		15580t, 125.0x22.9x8.4m, 8b,2vte, 11000hp, 16.5kts, 712p; compound: 457belt, 76deck, 432barbettes, 356CT; 2x2-343/30, 10x1-152/40, 16x1-57/40, 12x1-47/40, 7-450TT
		38	Empress of India	1893		
		39	Repulse	1894		
		40	Ramillies	1893		
		41	Resolution	1893		
		42	Revenge	1894		
43	Royal Oak	1894				
						15590t, 125.0x22.9x8.3m, 8b,2vte, 11000hp, 16.7kts, 690p; compound: 457belt,

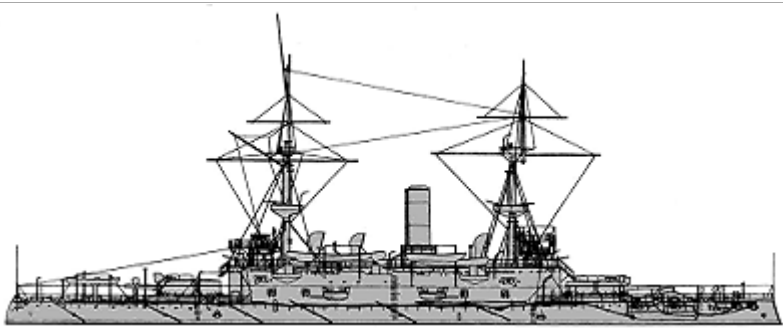
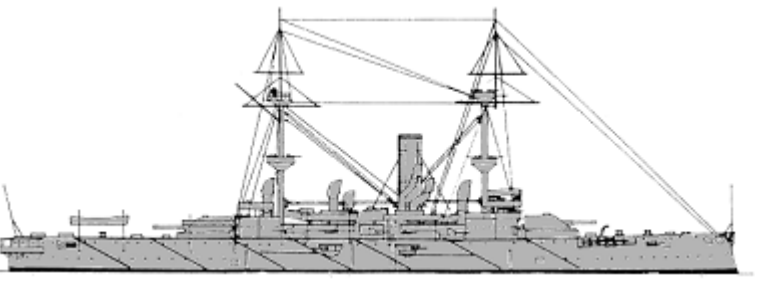
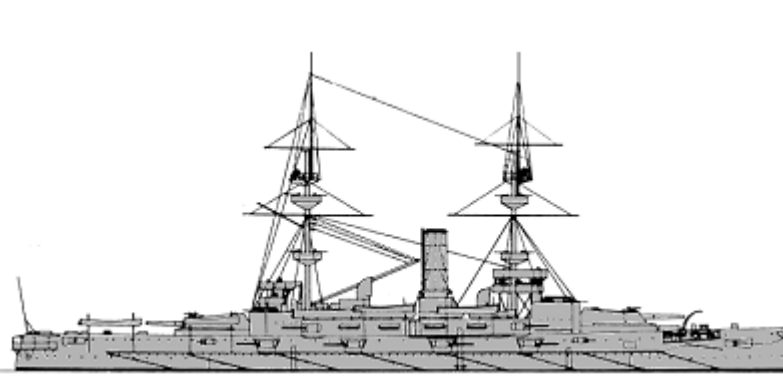
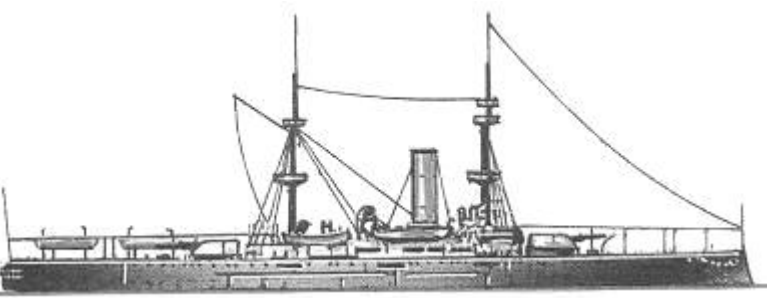
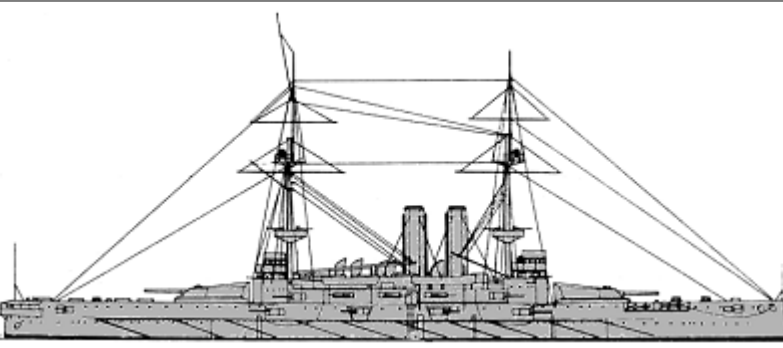
Hood	1	44	Hood	1893		76deck, 432turrets, 356CT; 2x2-343/30, 10x1-152/40, 10x1-57/40, 12x1-47/40, 5-450TT
Centurion	2	45	Centurion	1894		10500t, 109.7ppx21.3x7.8m, 8b,2vte, 13000hp, 18.5kts, 620p; compound: 305belt, 64(NS)deck, 152(Harvey) gun houses, 305CT; 2x2-254/32, 10x1-120/40, 8x1-57/40, 12x1-47/40, 7-450TT
		46	Barfleur	1894		
Majestic	9	47	Magnificent	1895		15730-16060T, 128.3X22.9X8.2m, 8b,2vte, 12000hp, 17kts, 672p; Harvey: 229belt, 102deck, 254gunhouses, 356CT; 2x2-305/35, 12x1-152/40, 16x1-76/40, 12x1-47/40, 5-450TT
		48	Majestic	1895		
		49	Prince George	1896		
		50	Victorious	1896		
		51	Jupiter	1897		
		52	Mars	1897		
		53	Hannibal	1898		
		54	Caesar	1898		
		55	Illustrious	1898		
Renown	1	56	Renown	1897		12350t, 124.4x22.0x8.2m, 8b,2vte, 12000hp, 18kts, 674p; Harvey: 203belt, 76deck, 152gunhouses, 229CT; 2x2-254/32, 10x1-152/40, 12x1-76/40, 12x1-47/40, 5-450TT
Canopus	1	57	Canopus	1899		14300t, 128.5x22.6x8.0m, 20b,2vte, 13500hp, 18kts, 682p; Harvey: 152(Krupp)belt, 76deck, 203gunhouses, 305CT; 2x2-305/35, 12x1-152/40, 10x1-76/40, 6x1-47/40, 4-450TT

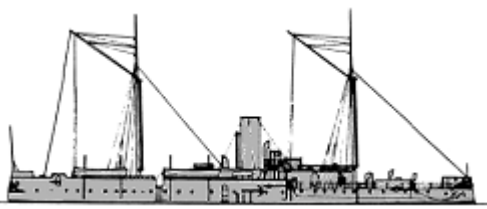
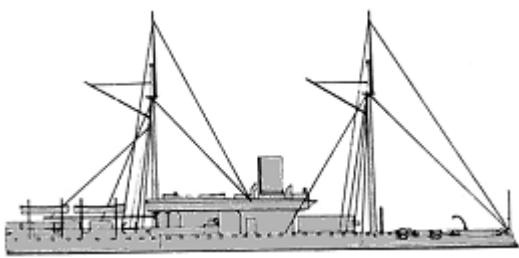
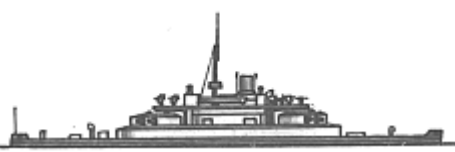
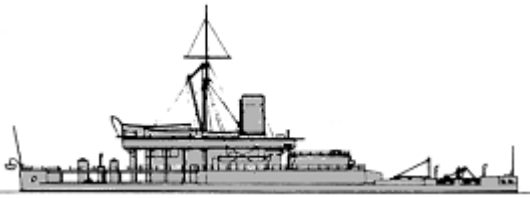
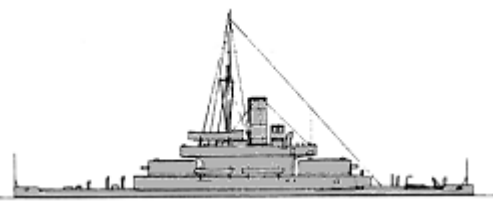

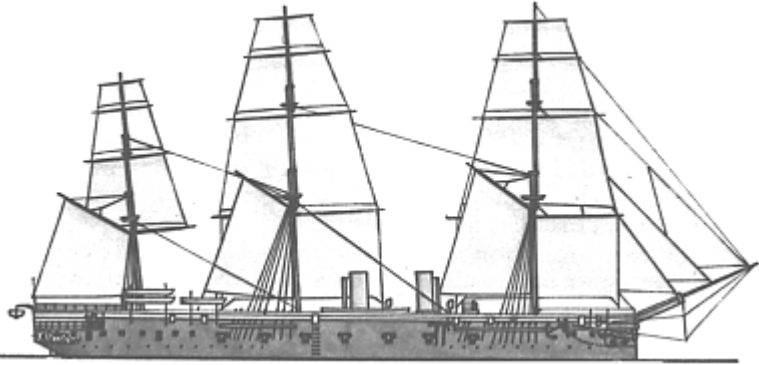

BC	Hotspur	1	1	Hotspur	1871		4331t, 71.6ppx15.2x6.1m, 2hse, 3497hp, 12.7kts, 209p; iron: 279belt, 70deck, 216(compound)turret, 254CT; 1x2-305/12MLR, 2x1-152/26, 2-356TT, 1torpedo boat
	Rupert	1	2	Rupert	1874		5440t, 80.5ppx16.2x6.9m, 2hse, 4630hp, 13.6kts, 217p; iron: 279belt, 76deck, 356turret, 305CT; 1x2-234/32, 2x1-152/26, 4x1-57/40, 6x1-47/40, 8x1-11.4, 4-356TT
MON	Cerberus	1	1	Magdala	1870		
	Glatton	1	2	Glatton	1872		4912t, 74.7ppx16.5x5.8m, 2hrccr, 2870hp, 12.1kts, 185p; iron: 305belt, 76deck, 356turret, 229CT; 1x2-305/12MLR, 3x1-57/40, 4x1-11.4, 2-356TC
	Cyclops		3	Cyclops	1877		3560t, 68.6ppx13.7x5.0m, 2hice(5,8)-2hidase(6,7), 1470-1755hp, 10.9-11.2kts, 150p; iron: 203belt, 38deck, 254turrets, 229CT; 2x2-254/15MLR, 4x1-47/40, 5x1-11.4
		4	Hecate	1877			
		5	Gorgon	1874			
		6	Hydra	1876			

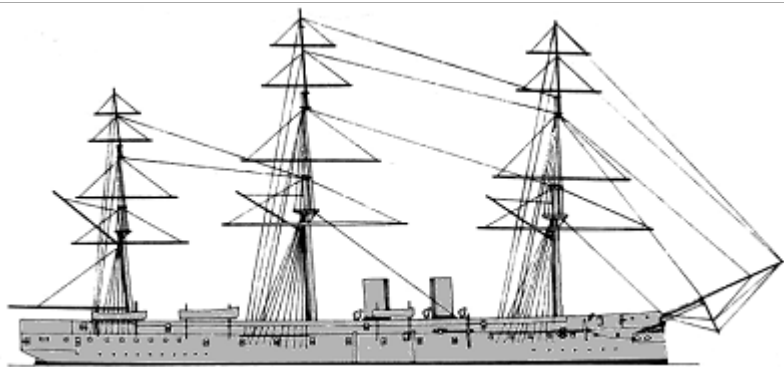
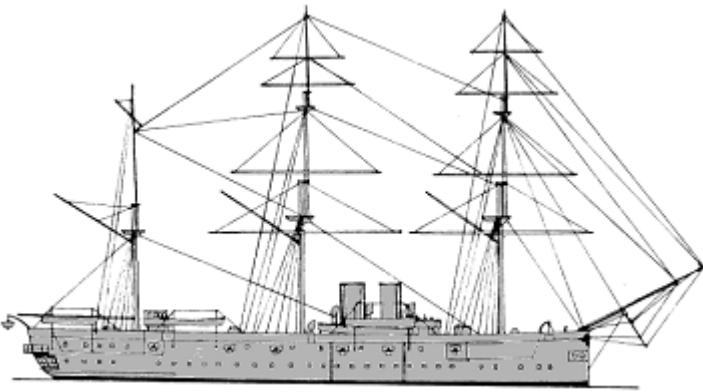
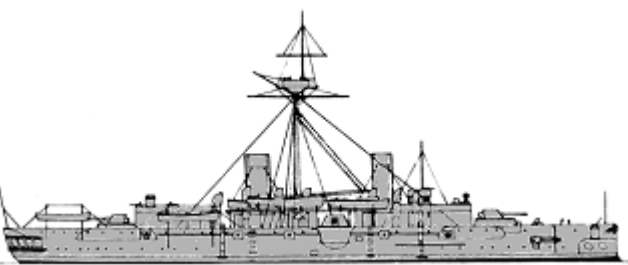
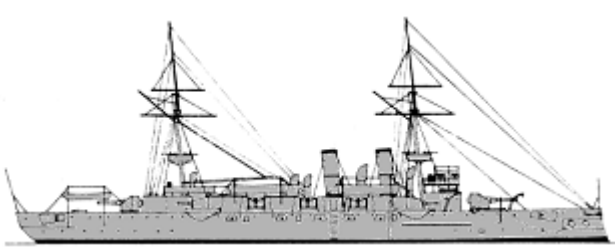
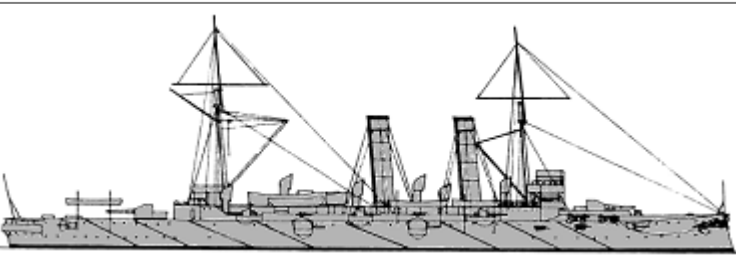
CRUISERS

	Raleigh	1	1	Raleigh	1874		5200t, 90.8ppx14.9x7.5m, 9b,1hse, 5639hp, 15.3kts, 530p; 2x1-229/14MLR, 6x1-178/16MLR, 6x1-160/16MLR, 8x1-152/26, 8x1-127/25, 4x1-76/20, 12x6-11.4, 2-356TC
							6250t, 101.8ppx15.8x8.1m, 10b,1hse, 7480hp, 16.2kts, 600p; 2x1-

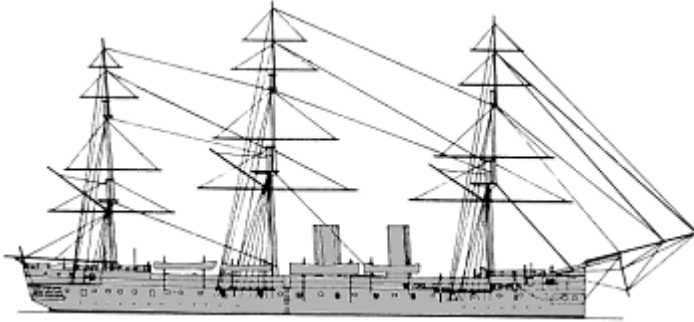
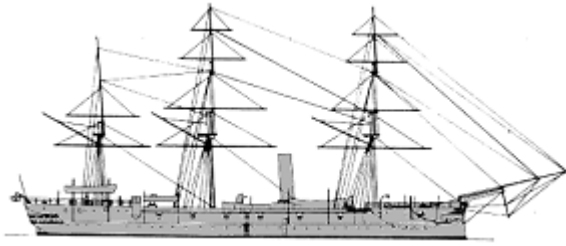
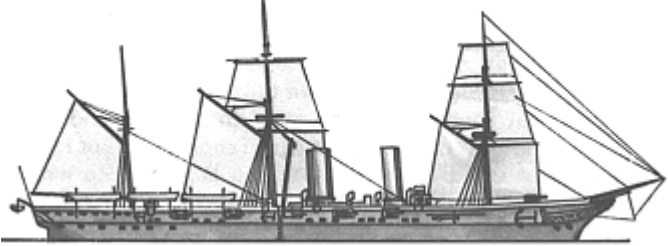

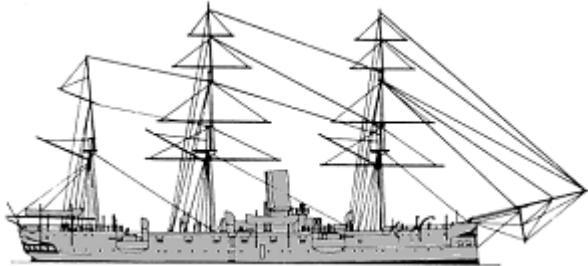

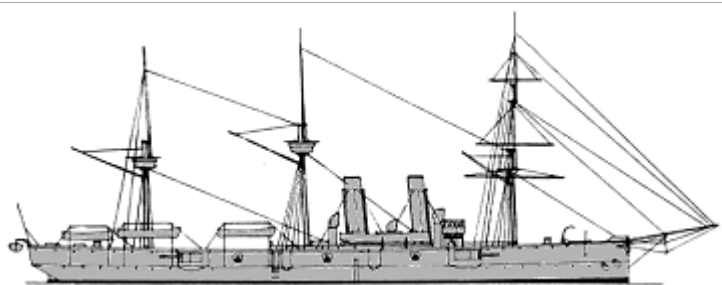
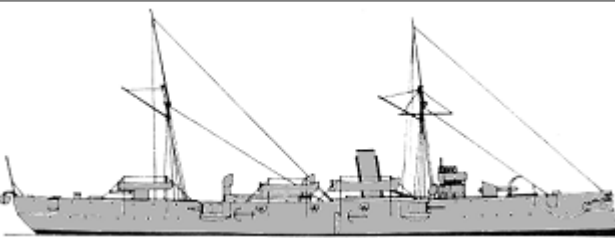
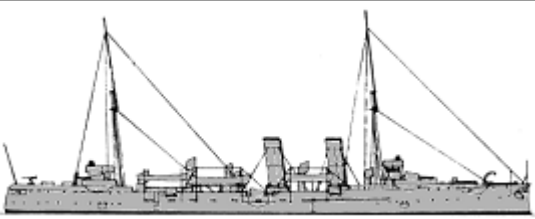
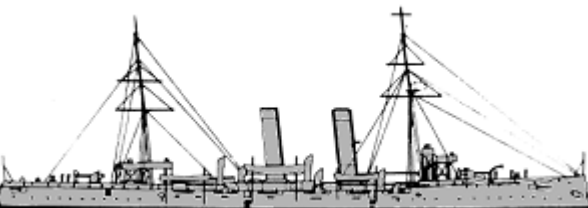

CA	Shah	1	2	Shah	1875		229/14MLR, 16x1-178/16MLR, 8x1-160/16MLR, 4x1-76/20, 12x6-11.4, 2-356TC
	Nelson	1	3	Nelson	1881		7473t, 85.3ppx18.3x7.6m, 10b,2ihce, 6624hp, 14kts, 560p; iron: 229belt, 76deck, 229CT; 4x1-254/15MLR, 8x1-229/14MLR, 4x1-120/40, 6x1-57/40, 14x1-47/40, 2-356TT
	Imperieuse	2	4	Imperieuse	1886		8500t, 96.0ppx18.9x8.2m, 12b,3ice, 10000hp, 16.7kts, 555p; compound: 254belt, 102deck, 203barbettes, 229CT; 4x1-234/32, 8x1-152/27, 4x1-57/40, 6-450TT
			5	Warspite	1888		
	Orlando	7	6	Orlando	1888		5600t, 91.4ppx17.1x6.9m, 4b,2vte, 8500hp, 18kts, 484p; compound: 254belt, 76deck, 305CT; 2x1-234/32, 10x1-152/27, 6x1-57/40, 10x1-47/40, 6-450TT
			7	Australia	1888		
			8	Undaunted	1889		
			9	Narcissus	1889		
			10	Galatea	1889		
			11	Immortalité	1889		
	Blake	2	12	Aurora	1889		9150t, 121.8x19.8x7.3m, 6b,2vte, 20000hp, 21.4kts, 570p; compound: 152deck, 114shields, 305CT; 2x1-234/32, 10x1-152/40, 16x1-47/40, 4-356TT
			13	Blake	1892		
			14	Blenheim	1894		
			15	Edgar	1893		
			16	Royal Arthur	1893		
			17	Hawke	1893		

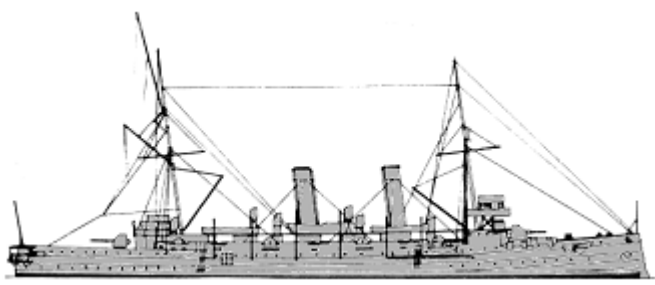
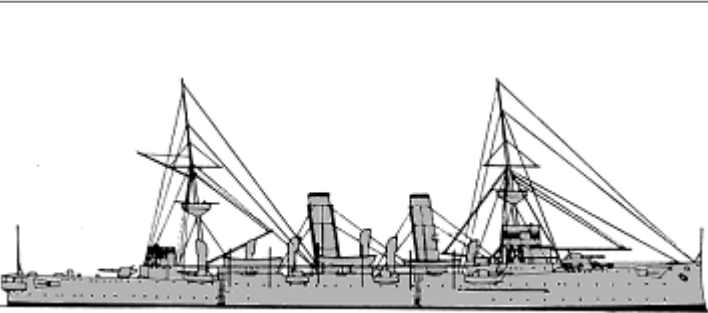
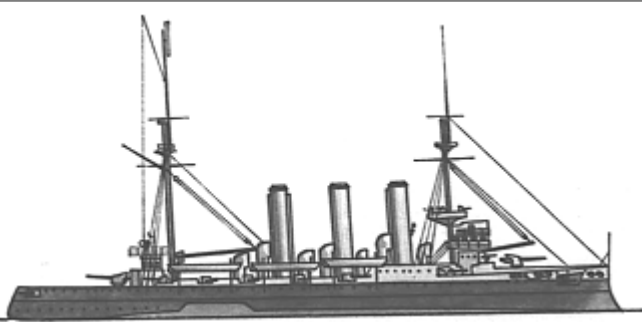
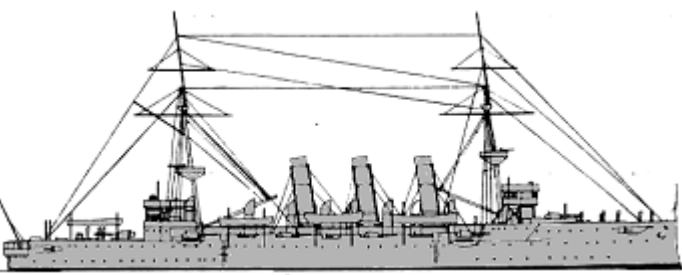
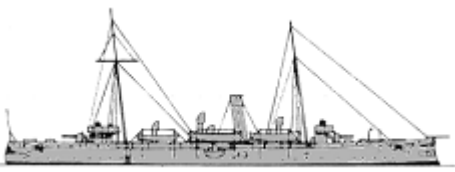
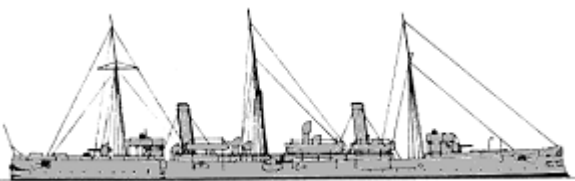

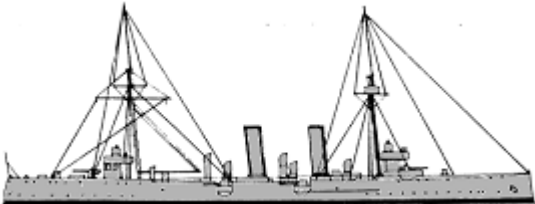
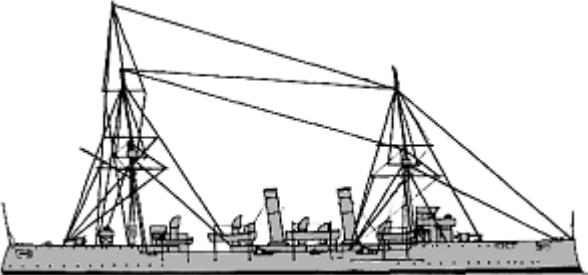
Edgar	9	18	Endymion	1894		7350(15,17-19,23)-7700(16,20-22)t, 118.1x18.3x7.2m, 5b,2vite, 12000hp, 20kts, 544p; steel: 127deck, 152casemates, 305CT; 2x1-234/32(15,17-19,21-23), 1x1-234/32(16,20), 10x1-152/40(15,17-19,21-23), 12x1-152/40(16,20), 12x1-57/40, 5x1-47/40, 4-450TT
		19	Grafton	1894		
		20	Crescent	1894		
		21	Gibraltar	1894		
		22	St. George	1894		
		23	Theseus	1896		
		24	Terrible	1898		
Powerful	2	25	Powerful	1897		14200t, 164.0x21.6x7.3m, 48b,2vte, 25000hp, 22kts, 894p; Harvey: 152deck, 152turrets, 305CT; 2x1-234/41, 12x1-152/40, 16x1-76/40, 12x1-47/40, 4-450TT
		26	Diadem	1898		
Diadem	4	27	Niobe	1898		11000t, 141.0x21.0x7.8m, 30b,2vte, 16500hp, 20.2kts, 677p; Harvey: 102deck, 114casemates, 305CT; 16x1-152/40, 14x1-76/40, 3x1-47/40, 3-450TT
		28	Europa	1899		
		29	Andromeda	1899		
		1	Volage	1870		
Volage	2	2	Active	1871		3078t, 82.3ppx12.8x6.7m, 5b1hset(1)-5b,1hr(2), 4530(1)-4130(2)hp, 15.3(1)-15(2)kts, 340p; 2x1-160/16MLR, 10x1-152/26, 2x1-76/20, 9x6-11.4, 2-356TC
		3	Ruby	1877		
Emerald	2	4	Garnet	1878		2120t, 67.1ppx12.2x5.5m, 6b,2hce, 1833(3)-2005(4)hp, 12.3(3)-13.2(4)kts, 232p; 12x1-160/16MLR(3), 14x1-127/25(4), 8x1-11.4

Bacchante	1	5	Boadicea	1877		178/14MLR, 2x1-160/16MLR, 2x1-152/26, 7x1-76/20, 10x6-11.4, 2-356TC
Comus	5	6	Comus	1879		2380t, 68.6ppx13.6x5.9m, 6b,1hce, 2420-2610hp, 12.9-13kts, 265p; steel: 13deck; 2x1-178/16MLR(7), 8x1-160/16MLR(6), 12x1-160/16MLR(7), 4x1-152/26(6,8,9), 10x1-152/26(10), 8x1-127/25(8,9), 2x1-76/19, 4x1-47/40(8), 1x1-47/40(9), 2-356TC
		7	Curacoa	1880		
		8	Champion	1880		
		9	Cleopatra	1880		
		10	Cordelia	1887		
Iris	2	11	Iris	1879		3730t, 101.5(11)-96.0(12)x14.0x6.7m, 12b,2hdace, 6000hp, 17.5kts, 275p; 13x1-127/25, 4x1-47/40, 4-356TC
		12	Mercury	1879		
Satellite	6	13	Satellite	1883		1420t, 61.0ppx11.6x4.8m, 8b,1hce, 1400-1640hp, 13-13.1kts, 175-200p; steel: 25deck; 1x1-152/26(17), 8x1-152/26(13-16), 10x1-127/25(17), 14x1-127/25(18), 4x1-11.4(13-17), 8x1-11.4(18)
		14	Heroine	1883		
		15	Hyacinth	1884		
		16	Royalist	1886		
		17	Rapid	1884		
		18	Pylades	1886		
Calypso	2	19	Calypso	1885		2770t, 71.6ppx13.6x6.1m, 6b,1hce, 3000hp, 13.7kts, 317p; steel: 13deck; 4x1-152/26, 12x1-127/25, 2x1-76/19, 10x1-11.4, 2-356TC
		20	Calliope	1887		
Leander	4	21	Leander	1885		4300t, 96.0x14.0x6.3m, 12b,2hdace, 5500hp, 16.5kts, 278p; steel: 38deck, 38shields; 10x1-152/26, 4x1-47/40(21,23,24), 8x1-47/40(22), 6x4-25/40(21,23,24), 2x4-25/40(22), 2x6-11.4, 4x5-11.4, 4-356TC
		22	Arethusa	1887		
		23	Phaeton	1886		
		24	Amphion	1886		

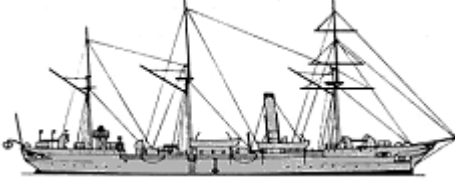
CL							
	Mersey	4	25	Mersey	1887		4050t, 96.0x14.0x5.9m, 12b,2hdace, 6000hp, 18kts, 325p; steel: 76deck, 51shields, 229CT; 2x1-203/30, 10x1-152/26, 3x1-57/40, 3x1-47/40, 9x1-11.4, (2+2)-356TT/TC
			26	Severn	1888		
			27	Thames	1888		
			28	Forth	1889		
	Medea	5	29	Magicienne	1889		2950(29,32,33)-2800(30,31)t, 80.8ppx12.8(29,32,33)-12.5(30,31)x5.0m, 6b,2hdace(29,32,33)-6b,2vce(30,31), 9000hp, 19.7(29,32,33)-20(30,31)kts, 218p; steel: 51deck, 114shields, 76CT; 6x1-152/26, 9x1-57/40, 1x1-47/40, 3x1-11.4, (2+2)-356TT/TC
			30	Medea	1889		
			31	Medusa	1889		
			32	Marathon	1889		
			33	Melpomene	1889		
	Apollo	21	34	Latona	1891		3400(34-44)-3600(45-54), 95.7x13.1(34-44)-13.3(45-54)x5.3(34-44)-5.6(45-54), 5b,2vte, 9000hp, 20(34-44)-19.7(45-54), 273p; steel: 51deck, 114shields, 76CT; 2x1-152/40, 6x1-120/40, 8x1-57/40, 1x1-47/40, 4x1-11.4, 4-356TT
			35	Melampus	1891		
			36	Andromache	1891		
			37	Terpsichore	1892		
			38	Naiad	1892		
			39	Thetis	1892		
			40	Sybille	1894		
			41	Apollo	1892		
			42	Tribune	1892		
			43	Sappho	1893		
			44	Scylla	1893		
45			Sirius	1892			
46			Pique	1893			
47			Spartan	1892			
48			Indefatigable	1892			
49			Rainbow	1893			
50			Intrepid	1892			
51	Brilliant	1893					
52	Retribution	1893					
53	Aeolus	1894					
54	Iphigenia	1893					
		55	Bonaventure	1894			
		56	Cambrian	1894			





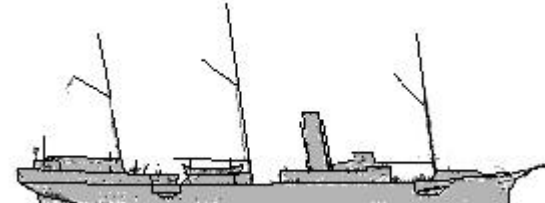
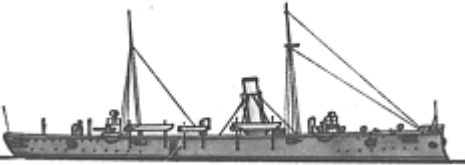
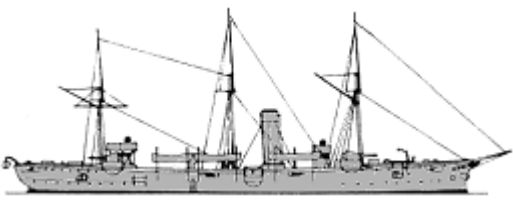

Astraea	8	57	Astraea	1895		4360t, 103.5x15.1x5.8m, 8b,2vte, 9500hp, 19.5kts, 318p; steel: 51deck, 114shields, 76CT; 2x1-152/40, 8x1-120/40, 10x1-57/40, 1x1-47/40, 4-450TT				
		58	Charybdis	1896						
		59	Fox	1896						
		60	Hermione	1896						
		61	Flora	1895						
		62	Forte	1895						
		Eclipse	9	63			Eclipse	1897		5600t, 113.7x16.3x6.3m, 8b,2vte, 9600hp, 19.5kts, 450p; Harvey: 76deck, 76shields, 152CT; 5x1-152/40, 6x1-120/40, 8x1-76/40, 6x1-47/40, 2x1-11.4, 3-450TT
				64			Talbot	1896		
65	Venus			1897						
66	Minerva			1897						
67	Juno			1897						
68	Diana			1897						
69	Doris			1897						
70	Dido			1898						
71	Isis			1898						
Arrogant	3	72	Arrogant	1898		5750t, 104.2x17.5x6.1m, 18b,2vte, 10000hp, 19kts, 480p; Harvey: 76deck, 114shields, 229CT; 4x1-152/40, 6x1-120/40, 8x1-76/40, 3x1-47/40, 5x1-11.4, 3-450TT				
		73	Furious	1898						
		74	Gladiator	1899						
Highflyer	2	75	Hermes	1899		5650t, 113.4x16.5x6.3m, 18b,2vte, 10000hp, 20kts, 450p; Harvey: 76deck, 76shields, 152CT; 11x1-152/40, 9x1-76/40, 6x1-47/40, 2-450TT				
		76	Highflyer	1899						
Barracouta	4	1	Barrosa	1890		1580t, 71.0x10.7x4.6m, 4b,2vte, 160p; steel: 51deck, 51shields; 6x1-120/40, 4x1-47/40, 2x1-11.4, 2-356TT				
		2	Barracouta	1891						
		3	Blanche	1891						
		4	Blonde	1891						
Barham	2	5	Barham	1891		1830t, 85.3ppx10.7x4.0m, 6b,2vte, 4700hp, 18kts, 169p; steel: 51deck, 51shields; 6x1-120/40, 4x1-47/40, 2x1-11.4, 2-356TT				
		6	Bellona	1891						
		7	Katoomba	1891						

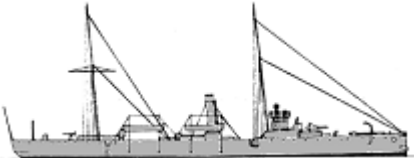



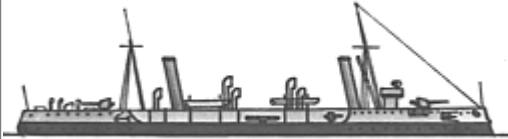









CLL	Pearl	9	8	Tauranga	1891		2575t, 84.7x12.5x4.7m, 4b,2vte, 7500hp, 19kts, 217p; steel: 51deck, 51shields, 76CT; 8x1-120/40, 8x1-47/40, 4x1-11.4, (2+2)-356TT/TC
			9	Mildura	1891		
			10	Ringarooma	1891		
			11	Wallaroo	1891		
			12	Pallas	1891		
			13	Phoebe	1892		
			14	Pearl	1892		
			15	Philomel	1891		
	Pelorus	6	16	Proserpine	1899		2135-2200t, 95.6x11.1x4.9m, 16b,2vte, 7000hp, 20kts, 224p; steel: 51deck, 76shields, 76CT; 8x1-102/40, 8x1-47/40, 3x1-7.7, 2-450TT
			17	Pelorus	1897		
			18	Pactolus	1898		
			19	Pegasus	1898		
			20	Pomone	1899		
			21	Prometheus	1899		
	SL	Osprey	2	1	Wild Swan	1876	
2				Pelican	1877		
Doterel		1	3	Gannet	1879		1130t, 58.8ppx11.0x4.8m, 3b1hce, 1107hp, 11.5kts, 150p; 2x1-178/16MLR, 2x1-127/25, 6x1-11.4
Mariner		4	4	Reindeer	1884		970t, 50.9ppx9.9x4.3m, 3b,1hce, 970-1230hp, 11.5(4,5)-12.5(6,7)kts, 126p; 6x1-127/25(4), 8x1-127/25(5-7), 8x1-11.4
			5	Mariner	1885		
			6	Icarus	1886		
			7	Melita	1889		
Nymphe		4	8	Swallow	1886		1140t, 59.4ppx8.5x3.8m, 4b,2hte, 1570(1,4)-2000(2,3)hp, 13.5(1,4)-14.5(2,3)kts, 138p; 8x1-127/25, 8x1-11.4
			9	Buzzard	1888		
			10	Nymphe	1889		
	11		Daphne	1889			
Beagle	2	12	Beagle	1889		1170t, 59.4ppx8.5x3.8m, 4b2hte, 2000hp, 14.5kts, 138p; steel: 37deck; 8x1-127/25, 4x4-25/40, 4x5-11.4	
		13	Basilisk	1889			



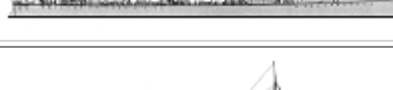

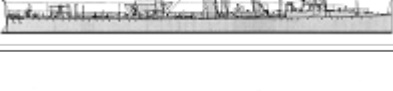





	Alert	2	14	Alert	1895		960t, 62.4x9.9x3.5m, 4b1vte, 1400hp, 13.2kts, 105p; 38deck; 6x1-102/40, 4x1-47/40, 2x1-11.4
			15	Torch	1895		
	Phoenix	2	16	Phoenix	1896		1050t, 62.4x9.9x4.2m, 4b,1vte, 1400hp, 13kts, 106p; 6x1-102/40, 4x1-47/40, 3x1-11.4
17			Algerine	1896			
Condor	1	18	Rosario	1899		980t, 62.2x9.9x3.5m, 4b,2vte, 1400hp, 13.5kts, 130p; steel: 38deck, 6shields; 6x1-102/40, 4x1-47/40	
DV	Surprise	2	1	Surprise	1886		1650-1700t, 83.9x9.9x4.0m, 4b,2hdace, 3030hp, 17kts, 93p; steel: 10deck; 4x1-127/25(12), 4x1-57/40(12), 10x1-57/40(13), 2x1-11.4(12)
			2	Alacrity	1886		
CT	Scout	2	1	Scout	1886		1580t, 68.6x10.4x4.4m, 4b,2hdace, 3200hp, 17kts, 147p; steel: 10deck, 25shields, 76TT; 4x1-120/40, 8x1-47/40, 2x1-11.4, (3+4)-356TT/TC
			2	Fearless	1887		
CT	Archer	7	3	Archer	1887		1950t, 73.2x11.0x4.4m, 4b,2hdace, 3500(3-8)-4500(9)hp, 16.5(3-8)-17.5(9)kts, 176p; steel: 10deck, 25shields, 76CT; 6x1-152/26, 8x1-47/40, 2x1-11.4, (1+4)-356TT/TC
			4	Mohawk	1887		
			5	Brisk	1888		
			6	Porpoise	1888		
			7	Cossack	1888		
			8	Tartar	1888		
9	Racoon	1888					

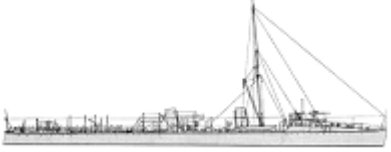



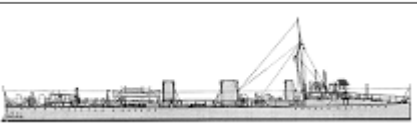

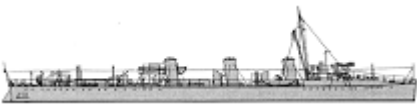









TORPEDO SHIPS





RT	Polyphemus	1	1	Polyphemus	1882		73.2ppx12.2x6.3m, 4b,2hce, 7000hp, 18kts, 146p; steel: 76deck; 6x1-57/40, 5-356TT
	Rattlesnake	1	1	Rattlesnake	1887		550t, 61.0ppx7.0x3.2m, 4b,2vte, 2700hp, 19.2kts, 66p; steel: 19deck; 1x1-102/27, 6x1-47/40, (2+2x1)-356TT

PGT	Grasshopper	2	Grasshopper	1888		526t, 61.0ppx7.0x3.2m, 4b,2vte, 2700hp, 19.2kts, 66p; 1x1-102/27, 6x1-47/40, (2+2x1)-356TT	
		3	Sandfly	1888			
		4	Spider	1888			
	Sharpshooter	13	5	Sharpshooter	1889		735t, 70.1ppx8.2x3.2m, 4b,2vte, 3600hp, 19kts, 91p; 2x1-120/40, 4x1-47/40, (1+2x2)-356TT
			6	Spanker	1890		
			7	Speedwell	1890		
			8	Sheldrake	1890		
			9	Skipjack	1891		
			10	Seagull	1891		
			11	Salamander	1891		
	12	Gleaner	1891				
	13	Gossamer	1891				
	Alarm	11	14	Jason	1893		810t, 70.1ppx8.2x3.7m, 4b,3vte, 3500(14-22,24)-5000(23)hp, 18.7(14-22,24)-20.5(23)kts, 91p; 2x1-120/40, 4x1-47/40, 1x5-11.4, (1+2x1)-356TT(14,17,20,22,23), (1+2x2)-356TT(15,16,18,19,21,24)
			15	Circe	1893		
			16	Hebe	1894		
			17	Onyx	1894		
			18	Leda	1893		
			19	Alarm	1894		
			20	Jaseur	1893		
			21	Renard	1894		
			22	Niger	1893		
			23	Speedy	1894		
	24	Antelope	1894				
	Dryad	5	25	Dryad	1894		1070t, 80.1x9.3x3.5m, 4b,2vte, 6000hp, 20kts, 120p; 2x1-120/40, 4x1-57/40, 1x5-11.4, (1+4x1)-450TT
26			Hazard	1894			
27			Harrier	1895			
28			Halcyon	1895			
29			Hussar	1895			
Havock	2	1	Havock	1894		275t, 56.4x5.7x2.2m, 2b,2vte(1)-8b,2vte(2), 3800hp, 26kts, 46p; 1x1-76/40, 3x1-57/40, (1+2x1)-450TT	
		2	Hornet	1894			
Daring	2	3	Daring	1895		288t, 56.4x5.8x2.1m, 3b,2vce, 3200hp, 27kts, 48p; 1x1-76/40, 3x1-57/40, (1+2x1)-450TT	
		4	Decoy	1895			
Ferret	2	5	Ferret	1895		280t, 60.1x6.0x2.7m, 4b,2vte, 4475hp, 27.2kts, 46p; 1x1-76/40, 3x1-57/40, (1+2x1)-450TT	
		6	Lynx	1895			
Ardent	3	7	Ardent	1895		295t, 61.5x5.8x2.2m, 3b,2vte, 4500(7,9)-4200(8)hp, 28(7)-29(8)-30(9)kts, 53p; 1x1-76/40, 5x1-57/40, 2x1-450TT	
		8	Boxer	1895			
		9	Bruizer	1895			
		10	Janus	1895			

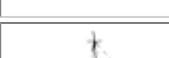

DD	Janus	3	11	Lightning	1896		320t, 61.1x5.9x2.4m, 4b,2vte, 3900hp, 28kts, 54p; 1x1-76/40, 5x1-57/40, 2x1-450TT	
			12	Porcupine	1896			
	Banshee	3	13	Banshee	1895		345t, 64.9x5.9x2.9m, 4b,2vte, 4400hp, 28kts, 58p; 1x1-76/40, 5x1-57/40, 2x1-450TT	
			14	Contest	1895			
	Handy	3	15	Dragon	1895		310t, 60.1x5.9x2.3m, 3b,2vte, 4000hp, 27kts, 55p; 1x1-76/40, 5x1-57/40, 2x1-450TT	
			16	Handy	1895			
	Rocket	3	17	Hart	1896		325t, 62.2x6.0x2.21m, 4b,2vte, 4100hp, 27kts, 58p; 1x1-76/40, 5x1-57/40, 2x1-450TT	
			18	Hunter	1896			
	Charger	3	19	Rocket	1895		295t, 59.4x5.6x2.2m, 4b,2vte, 3100(22,23)-3800(24)hp, 26.2kts, 53p; 1x1-76/40, 5x1-57/40, 2x1-450TT	
			20	Shark	1895			
	Haughty	2	21	Surly	1895		325t, 61.0x5.9x2.4m, 8b,2vte, 4200hp, 27kts, 54p; 1x1-76/40, 5x1-57/40, 2x1-450TT	
			22	Charger	1896			
	Salmon	2	23	Hasty	1896		340t, 61.5x6.0x2.4m, 8b,2vte, 3700hp, 27kts, 52p; 1x1-76/40, 5x1-57/40, 2x1-450TT	
			24	Dasher	1896			
	Sunfish	3	25	Haughty	1896		340t, 62.2x5.8x2.6m, 8b,2vte, 4000hp, 27kts, 58p; 1x1-76/40, 5x1-57/40, 2x1-450TT	
			26	Hardy	1896			
	Sturgeon	3	27	Salmon	1896		340t, 59.3x5.8x2.3m, 4b,2vte, 4000hp, 27.8kts, 52p; 1x1-76/40, 5x1-57/40, 2x1-450TT	
			28	Snapper	1896			
	Swordfish	2	29	Sunfish	1896		355t, 62.3x5.8x2.4m, 8b,2vte, 4500hp, 27kts, 58p; 1x1-76/40, 5x1-57/40, 2x1-450TT	
			30	Opossum	1896			
	Desperate	4	31	Ranger	1896		350t, 64.0x6.0x2.1m, 3b,2vte, 5700hp, 30kts, 54p; 1x1-76/40, 5x1-57/40, 2x1-450TT	
			32	Sturgeon	1896			
	Quail	4	33	Starfish	1896		415t, 66.5x6.6x2.9m, 4b,2vte, 6300hp, 30kts, 56p; 1x1-76/40, 5x1-57/40, 2x1-450TT	
			34	Skate	1896			
	Avon	2	35	Swordfish	1896		405t, 65.3x6.1x2.5m, 4b,2vte, 6300hp, 30kts, 60p; 1x1-76/40, 5x1-57/40, 2x1-450TT	
			36	Spitfire	1896			
				37	Desperate	1897		
				38	Fame	1897		
				39	Foam	1897		
				40	Mallard	1897		
				41	Quail	1897		
				42	Sparrowhawk	1897		
				43	Thrasher	1897		
				44	Virago	1897		
				45	Avon	1899		
				46	Bittern	1897		



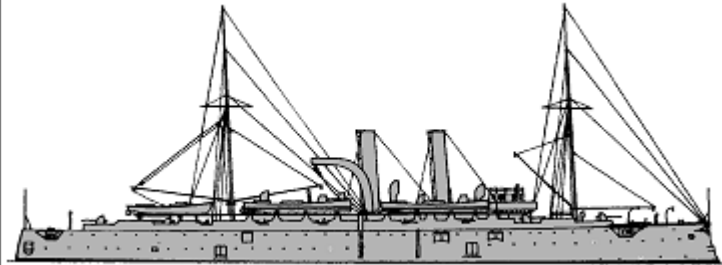

Earnest	6	47	Earnest	1897		415t, 66.5x6.6x3.0m, 4b,2vte, 6300hp, 30kts, 56p; 1x1-76/40, 5x1-57/40, 2x1-450TT
		48	Griffon	1897		
		49	Locust	1898		
		50	Panther	1898		
		51	Seal	1898		
		52	Wolf	1898		
Star	6	53	Star	1898		440t, 67.1x6.4x3.0m, 4b,2vte, 6200hp, 30kts, 58p; 1x1-76/40, 5x1-57/40, 2x1-450TT
		54	Whiting	1897		
		55	Bat	1897		
		56	Crane	1898		
		57	Chamois	1897		
		58	Flying Fish	1898		
Angler	2	59	Angler	1898		352t, 64.0x6.0x2.1m, 3b,2vte, 5700hp, 30kts, 54p; 1x1-76/40, 5x1-57/40, 2x1-450TT
		60	Ariel	1898		
Violet	2	61	Violet	1898		400t, 65.2(61)-65.5(62)x6.4x2.9m, 4b,2vte, 6300hp, 30kts, 58p; 1x1-76/40, 5x1-57/40, 2x1-450TT
		62	Sylvia	1899		
Gipsy	3	63	Gipsy	1898		400t, 65.7x6.5x2.5m, 4b,2vte, 6300hp, 30kts, 60p; 1x1-76/40, 5x1-57/40, 2x1-450TT
		64	Osprey	1898		
		65	Fairy	1898		
Fawn	2	66	Fawn	1898		440t, 67.1x6.4x3.0m, 4b,2vte, 6200hp, 30kts, 58p; 1x1-76/40, 5x1-57/40, 2x1-450TT
		67	Flirt	1899		
Conflict	3	68	Conflict	1899		360t, 62.7x6.1x2.5m, 3b,2vte, 4500hp, 27kts, 54p; 1x1-76/40, 5x1-57/40, 2x1-450TT
		69	Teazer	1899		
		70	Wizard	1899		
Cheerful	1	71	Mermaid	1899		400t, 65.5x6.4x2.5m, 4b,2vte, 6100hp, 30kts, 58p; 1x1-76/40, 5x1-57/40, 2x1-450TT
Coquette	2	72	Coquette	1899		367t, 64.0x6.0x2.3m, 3b,2vte, 5700hp, 30kts, 54p; 1x1-76/40, 5x1-57/40, 2x1-450TT
		73	Cynthia	1899		
Leopard	1	74	Leopard	1899		400t, 65.3x6.1x2.5m, 4b,2vte, 6300hp, 30kts, 60p; 1x1-76/40, 5x1-57/40, 2x1-450TT
Leven	1	75	Leven	1899		420t, 65.7x6.5x2.5m, 4b,2vte, 6100hp, 30kts, 58p; 1x1-76/40, 5x1-57/40, 2x1-450TT
TB2	9	1 - 9	TB3, 4, 6-12	1878 - 1880		33t, 26.5(1-6,8,9)-27.9(7)x3.1x1.6m, 1b,1hce, 460hp, 20kts, 15p; 2-356TC





TB	TB17	2	10 - 11	TB17, 18	1878		33t, 26.2x3.4x1.4m, 1b,1hce, 450hp, 21kts, 15p; 2-356TC
	TB14	1	12	TB14	1879		33t, 26.2x3.4x1.4m, 1b1hce, 550hp, 21.7kts, 15p; 2-356TC
	TB15	1	13	TB15	1879		28t, 26.5x3.1x1.7m, 1b,1hce, 450hp, 21kts, 15p; 2-356TC
	TB20	1	14	TB20	1880		28t, 26.5x3.1x1.2m, 1b,1hce, 360hp, 16.7kts, 15p; 2-356TC
	TB21	2	15, 16	TB21, 22	1885		63t, 34.6x3.8x1.8m, 1b,1hce, 730hp, 18kts, 14p; 2x1-25/40, (2+1x1)-356TT
	TB23	2	17, 18	TB23, 24	1886		67t, 34.6x3.8x2.1m, 1b,1hce, 600(17)-500(18)hp, 18.7kts, 14p; 2x1-47/40, (2+1x1)-356TT
	TB25	1	19	TB25	1886		60t, 39.1x3.8x1.8m, 1b,1hce, 591hp, 19.4kts, 16p; 3x2-25/40, 2x2-356TT
	TB26	23	20 - 42	TB26, 27, 29, 41-60	1886 - 1887		60t, 38.9x3.8x2.5m, 1b,1hce, 700-750hp, 19.5-21.5kts, 16p; 3x2-25/40, 2x2-356TT
	TB30	21	43 - 63	TB30-33, 61-74, 76-78	1886 - 1887		60t, 38.2x4.0x2.5m, 1b,1hce, 670hp, 19.5kts, 16p; 2x1-25/40, (1+2x2)-356TT
	TB34	5	64 - 68	TB34-38	1886 - 1887		60(64-66)-66(67,68)t, 38.1pp(64-66)-40.3pp(67,68)x4.4x1.3m, 1b,1hce, 950hp, 18-19kts, 16p; 2x1-47/40(67,68), 2x1-25/40(64-66), (1+2x2)-356TT
	TB79	1	69	TB79	1886		75t, 39.2x4.0x1.7m, 1b,1vte, 1000hp, 22.2kts, 16p; 2x1-47/40, (2+1x1)-356TT
	TB80	1	70	TB80	1887		105t, 41.2ppx4.3x1.8m, 2b,1vte, 1539hp, 23kts, 21p; 3x1-47/40, (1+1x2)-356TT
	TB39	2	71, 72	TB39, 40	1885	No picture	40t, 30.5ppx3.8x1.2m, 1b,1hce, 500hp, 15p; 2x2-25/40, 1x1-356TT
	Baluchi	3	73 - 75	TB1 Baluchi, TB2 Karen, TB3 Pathan	1888		96t, 41.0x4.5x2.1m, 2b,1hce, 1260hp, 23kts, 18p; 2x2-25/40, (1+2x2)-356TT
	Gurkha	1	76	TB7 Gurkha	1888		92t, 41.2x4.3x2.1m, 2b,1hce, 1000hp, 21.5kts, 18p; 2x2-25/40, (1+2x2)-356TT
	Mahratta	3	77 - 79	TB4 Mahratta, TB5 Sikh, TB6 Rajput	1889		95t, 41.2x4.4x2.3m, 2b,1hce, 1000hp, 22kts, 18p; 2x2-25/40, (1+2x2)-356TT
	TB82	6	80 - 85	TB82-87	1889		85t, 39.7ppx4.1x1.8m, 1b,1vte, 1800hp, 23kts, 19p; 3x1-47/40, (1+1x2)-356TT
	TB88	2	86	TB88	1894		112t, 43.3ppx4.5x2.3m, 1b,1vte, 1850hp, 23.5kts, 18p; 3x1-47/40, (1+1x2)-450TT
			87	TB89	1894		
	TB91	2	88	TB91	1894		141t, 43.3(89)-42.8(90)x4.7x2.3m, 1b,1vte, 2350hp, 24.5kts, 18p; 3x1-47/40, (1+1x2)-450TT
		89	TB92	1894			
TB93	1	90	TB93	1894		136t, 42.8x4.7x1.6m, 2b,2vte, 2200hp, 23.5kts, 18p; 3x1-47/40, (1+1x2)-450TT	
TB94	3	91	TB94	1894		130t, 43.4ppx4.7x2.7m, 2b,2vte, 2000hp, 23kts, 18p; 3x1-47/40, (1+1x2)-450TT	
		92	TB95	1895			
		93	TB96	1895			
TB97	1	94	TB97	1894		130t, 42.8ppx4.9x2.3m, 2b,2vte, 2000hp, 23kts, 18p; 3x1-47/40, (1+1x2)-450TT	
TB90	1	95	TB90	1895		112t, 42.8ppx4.4x2.0m, 1b,1vte, 1500hp, 23kts, 18p; 3x1-47/40, (1+1x2)-450TT	

TB2cl	TB51	11	1 - 11	TB51-61	1878 - 1879		11t, 18.5x2.3x0.9m, 1b,1hce, 120-150hp, 15kts, 7p; 2-356TC
	TB63	1	12	TB63	1878		15t, 18.3x2.3xm, 1b,1hce, hp, 16kts, 7p; 2-356TC
	TB64	8	13 - 20	TB64-67, 69-71, 73	1880 - 1882	No picture	13t, 19.2-20.1ppx2.4x1.0m, 1b,1hce, 110hp, 16.5kts, 7p; 2-356TC
	TB76	18	21 - 38	TB76-82, 84-92, 94, 95	1882 - 1883	No picture	13t, 19.5x2.3x1.1m, 1b,1hce, 170hp, 16.5kts, 7p; 2-356TT
	TB74	4	39 - 42	TB74, 75, 96, 97	1883	No picture	12t, 18.5pp-19.4ppx2.4x1.1m, 1b,1hce, 220hp, 16kts, 7p; 1x1-11.4, 2-356TT
	TB98	1	43	TB98	1883	No picture	15t, 22.2x2.3x0.8m, 1b,1hce, 167hp, 11.7kts, 7p; 2-356TT
	WTB1	12	44 - 55	WTB1-12	1883 - 1888	No picture	11-14t, 17.1x2.8x1.5m, 1b,1hce, 140-200hp, 16kts, 9p; (1-2)x1-11.4, 1-356TT or 2-356TC or 1x1-356TT
	TB99	2	56, 57	TB99, 100	1885 - 1886	No picture	12t, 19.8x2.4x1.1m, 1b,1hce, 189hp, 16.8kts, 7p; 2-356TT
	TB49	2	58, 59	TB49, 50	1888		15-16t, 18.1pp-18.3ppx2.5-2.6x0.9m, 1b,1vte, 9p; 1x1-25/40, 1x1-356TT
	TB39	10	60 - 69	TB39 - 48	1889		17t, 18.3ppx2.8xm, 1b,1vte, 240hp, 16.5kts, 9p; 1x1-25/40, 2-356TC
CTB	Hecla	1	1	Hecla	1879	No picture	6400t, 119.6ppx11.8x6.9m, b,2hice, 1758hp, 12.1kts, 277p; 4x1-160/16MLR, 1x1-127/25, 1x1-121/21, 4 TB2cl
	Vulcan	1	2	Vulcan	1891		6620t, 113.7x17.7x6.7m, 5b,2vte, 12000hp, 20kts, 432p; steel: 127deck, 152CT; 8x1-120/40, 12x1-47/40, 12x1-11.4, 6TT, 9 TB2cl

OTHER FIGHTING SHIPS

Staunch	1	1	Staunch	1868		200t, 22.9x7.6x2.0m, 1b,2hse, 134hp, 7.7kts, 31p; 1x1-229MLR
Plucky	1	2	Plucky	1870		212t, 24.4x7.7x1.9m, 1b,2hse, 234hp, 7.7kts, 31p; 1x1-229MLR
		3	Blazer	1870		
		4	Comet	1870		
		5	Bustard	1871		
		6	Kite	1871		
		7	Scourge	1871		
		8	Mastiff	1871		
		9	Bloodhound	1871		
		10	Arrow	1871		
		11	Bonetta	1871		
		12	Badger	1872		

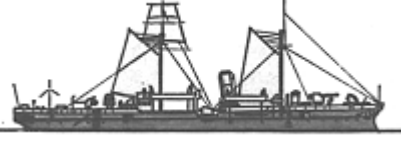
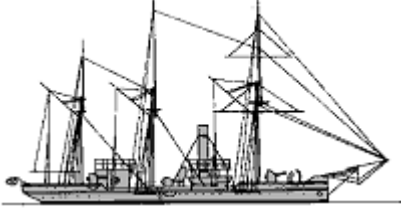
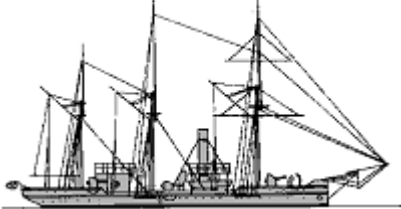
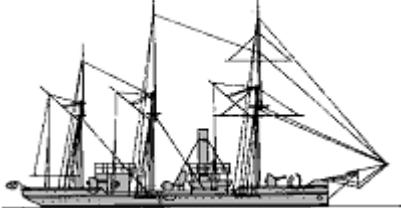
Ant	23	13	Fidget	1872		254t, 25.9x8.0x1.8-2.0m, 1b,2hse(t), 260hp, 8.5kts, 30p; 1x1-254MLR
		14	Bulldog	1872		
		15	Pike	1872		
		16	Pickle	1872		
		17	Snap	1872		
		18	Ant	1873		
		19	Cuckoo	1873		
		20	Hyaena	1873		
		21	Weazel	1873		
		22	Gadfly	1879		
		23	Pincher	1879		
		24	Griper	1879		
		25	Tickler	1879		
Ariel	1	26	Goshawk	1873	No picture	430t, 38.1ppx6.9x3.2m, 2b,1hce, 484hp, 9.5kts, 40p; 2x1-127/25, 2x1-95/21
Forester	3	27	Firm	1877		455t, 38.1ppx7.2x3.2m, 2b,2hce, 500hp, 10kts, 60p; 2x1-127/25, 2x1-95/21
		28	Firebrand	1877		
		29	Firefly	1877		
Medina	11	30	Medina	1876		363t, 33.5x10.4x1.8m, 1b,2hse, 310hp, 9.5kts, 51p; 3x1-160/16MLR
		31	Medway	1876		
		32	Sabrina	1876		
		33	Spey	1876		
		34	Tay	1876		
		35	Tees	1876		
		36	Don	1877		
		37	Esk	1877		
		38	Slaney	1877		
		39	Trent	1877		
40	Tweed	1877				
PG Linnet	2	41	Swift	1880		788t, 50.3ppx8.8x3.3m, 4b,1hce, 1010-1050hp, 11.8kts, 92p; 2x1-178/14MLR, 3x1-95/21
		42	Linnet	1880		
Banterer	7	43	Redwing	1880		465t, 38.1ppx7.2x3.1m, 4b,1hce, 440hp, 9.5kts, 60p; 2x1-127/25, 2x1-95/21, 2x1-25/40
		44	Grappler	1881		
		45	Banterer	1882		
		46	Espoir	1883		
		47	Bullfrog	1885		
48	Cockchafer	1883				

		49	Raven	1883		
Bouncer	2	50	Bouncer	1881		265t, 26.6x8.0x2.0m, 1b,2hse, 230hp, 8.5kts, 30p; 1x1-254/15MLR
		51	Insolent	1881		
Handy	1	52	Excellent	1883	No picture	508t, 35.1x11.3x2.8m, 2b,2hse, 310hp, 8.5kts; 1x1-343/30
Albacore	3	53	Albacore	1884		560t, 41.2ppx7.9x2.6m, 4b,1vce, 650hp, 10.7kts, 60p; 2x1-127/25, 2x1-102/27, 2x1-25/40
		54	Mistletoe	1884		
		55	Watchful	1884		
Curlew	2	56	Curlew	1886		950t, 59.4ppx8.5x3.2m, 4b,2hdace, 1500hp, 14.5kts, 46p; 1x1-152/26, 3x1-127/25, 7x1-11.4, (1+2)-356TT/TC
		57	Landrail	1887		
Bramble	3	58	Rattler	1887		810t, 50.3ppx8.8x3.4m, 2b,1vte, 1200(57)-1000(58,59)hp, 13kts, 76p; 6x1-102/40, 4x1-11.4
		59	Lizard	1887		
		60	Cockatrice	1887		
Pigmy	6	61	Pheasant	1888		755t, 50.3ppx9.1x3.4m, 2b,1vte, 1200hp, 13.2kts, 76p; 6x1-102/27, 4x1-11.4
		62	Partridge	1888		
		63	Peacock	1888		
		64	Pigmy	1889		
		65	Pigeon	1889		
		66	Plover	1889		
Redbreast	9	67	Goldfinch	1889		805t, 50.3ppx9.5x3.4m, 2b,1vte, 1200hp, 13kts, 76p; 6x1-102/27(63,65-71), 6x1-102/28(64), 2x1-47/40(63,64,69-71), 4x1-11.4(65-68), 2x1-11.4(63,64,69-71)
		68	Lapwing	1889		
		69	Magpie	1889		
		70	Redbreast	1889		
		71	Redpole	1890		
		72	Ringdove	1890		
		73	Sparrow	1890		
		74	Thrush	1890		
		75	Widgeon	1890		
Bramble	1	76	Dwarf	1899		710t, 57.2x10.1x2.4m, 4b,2vte, 1300hp, 13.5kts, 85p; 2x1-102/40, 4x1-76/40, 10x1-11.4
APG -	2	1	Lady Loch	1886		336t; 1x1-152/26
		2	Otter	1884		220t
Heron	4	1-4	Nightingale, Robin, Sandpiper, Snipe	1898	No picture	85t, 32.8x6.1x0.6m, 1b,1vte, 240hp, 9kts, 25p; 2x1-57/40

PGR						
	Woodcock	2	5	Woodcock	1898	No picture
			6	Woodlark	1898	
150t, 44.2x7.3x0.6m, 1b,1vte, 550hp, 13kts, 25p; 2x1-57/40, 4x1-7.9						



© Ivan Gogin, 2014

[home](#)



[World navies yesterday](#)

[1900](#)

United States of America 01 January 1900

CAPITAL SHIPS

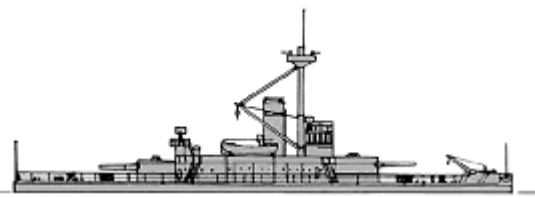
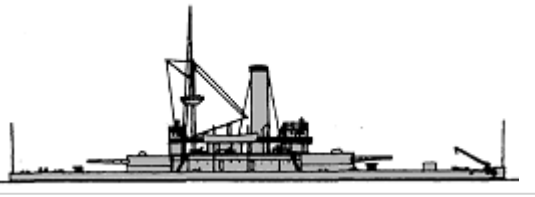
BB	Texas	1	1		Texas	1895		6665t, 94.1x19.5x6.9m, 4b,2vte, 8600hp, 17kts, 392p; Harvey: 305belt, 76deck, 305turrets, 305CT; 2x1-305/35, 2x1-152/35, 4x1-152/30, 10x1-57/45, 2x1-57/40, 6x1-37/40, 4x5-37/20, 4-356TT
	Indiana	3	2	B1	Indiana	1895		11688t, 107.0x21.1x7/3m, 6b,2vte, 9000hp, 15kts, 473p; Harvey: 457belt, 76deck, 432turrets, 254CT; 2x2-330/35, 4x2-203/37, 4x1-152/40, 20x1-57/40, 6x5-37/20, 6-450TT
			3	B2	Massachusetts	1896		
			4	B3	Oregon	1896		
	Iowa	1	5	B4	Iowa	1897		12647t, 110.5x22.0x7.3m, 5b,2vte, 11000hp, 16kts, 486p; Harvey: 356belt, 76deck, 381turrets, 254CT; 2x2-305/35, 4x2-203/37, 6x1-102/40, 20x1-57/40, 4x5-37/20, 4-356TT
MON	Passaic	6	1		Catskill	1863		1875t, 61.0x14.0x3.2m, 2b,1vl, 320hp, 7kts, 75p; iron: 127side, 51deck, 279turret; 1x2-381/11, 2x1-76/11
			2		Lehigh	1863		
			3		Montauk	1862		
			4		Nahant	1862		
			5		Nantucket	1863		
			6		Jason	1863		
	Canonicus	3	7		Canonicus	1864		2100t, (68.0-68.6)x(13.1-13.2)x(3.8-4.0)m, 2b,1vl, 320hp, 8kts, 100p; iron: 127side, 38deck, 254turret; 1x2-381/12
			8		Mahopac	1864		
			9		Manhattan	1864		
	Amphitrite	4	10	M2	Amphitrite	1895		3990t, 80.1(10)-79.9(11)-80.2(12,13)x16.9x4.4(10-12)-4.5(13)m, 4b,2hce(10)-4b,2hte(11)-6b,2hce(12,13), 1600(10,12,13)-3000(11)hp, 12(10,12,13)-14.5(11)kts, 150-191p; steel, iron: 229(10,11)-178(12,13)belt, 44deck, 190(10,11)-292(12,13)turrets, 190(10-12)-229(13)CT; 2x2-254/31(10-12), 1x2-254/35(13), 1x2-254/31(13), 2x1-102/40(10,11), 2x1-57/40, 2x5-37/20
			11	M3	Monadnock	1896		
			12	M4	Terror	1896		
			13	M5	Miantonomoh	1891		

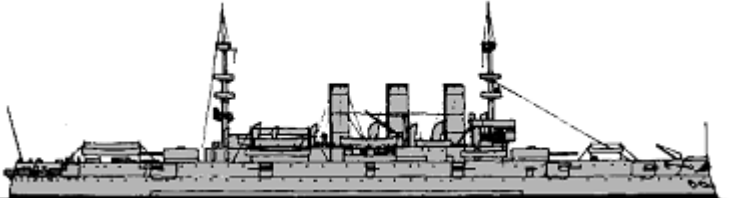
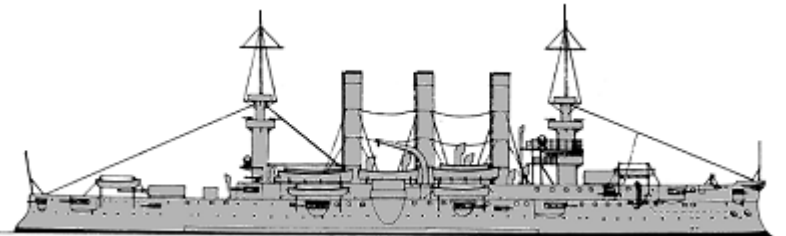
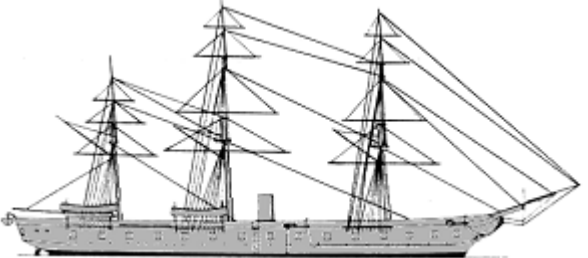

								
	Monterey	1	14	M6	Monterey	1893		4084t, 79.5x18.0x4.5m, 4b,2vte, 5250hp, 13.6kts, 218p; Harvey: 330belt, 64deck, 203turrets, 254CT; 1x2-305/35, 1x2-254/31, 6x1-57/40
	Puritan	1	15	M1	Puritan (TS)	1896		6060t, 90.3x18.3x5.5m, 8b,2hce, 3700hp, 12.4kts, 200p; Harvey: 356belt, 51deck, 203turrets, 254CT; 2x2-305/35, 6x1-102/40, 6x1-57/40

CRUISERS

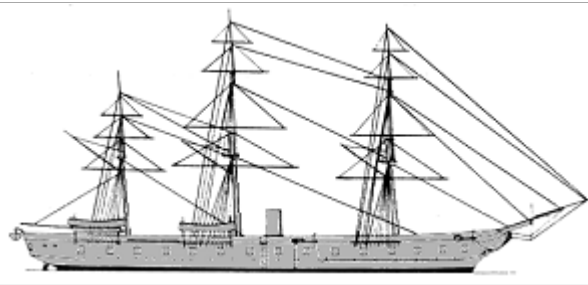
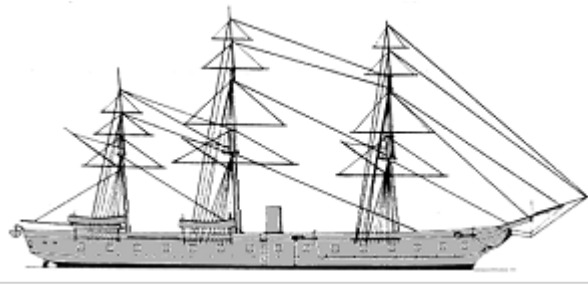
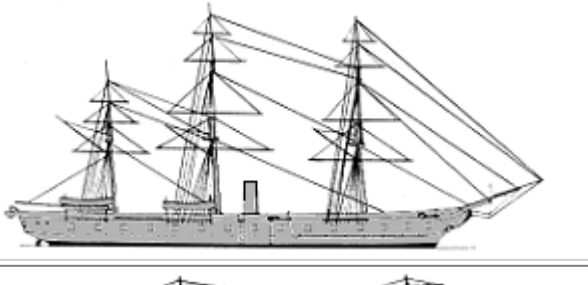
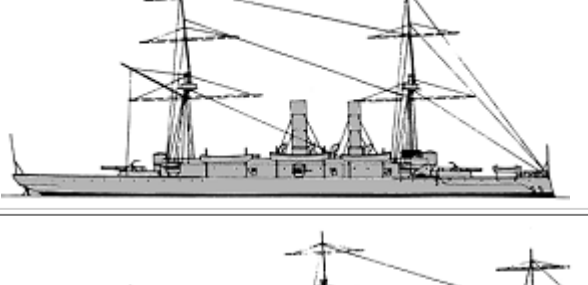
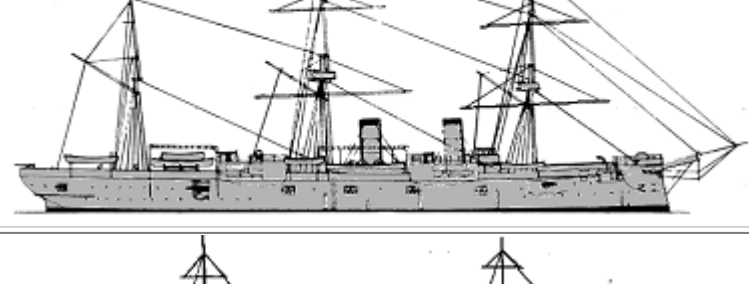
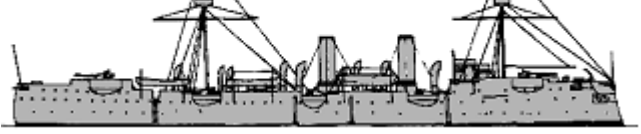

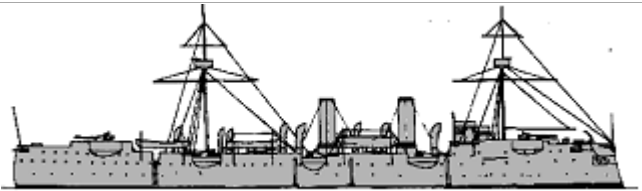
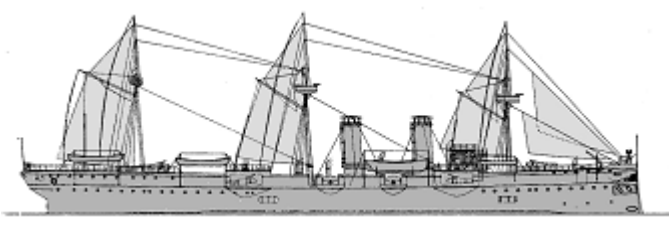
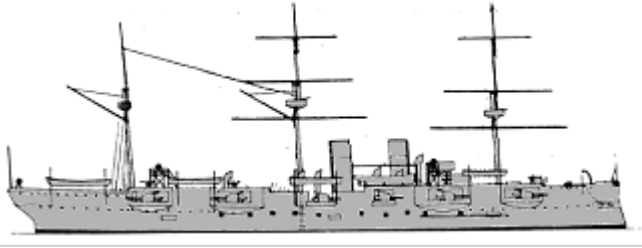
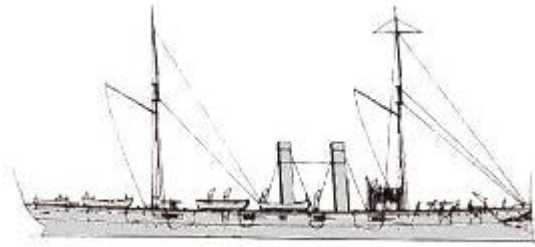
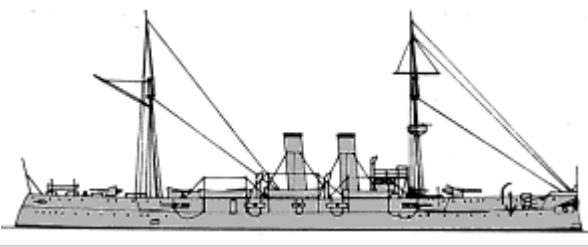
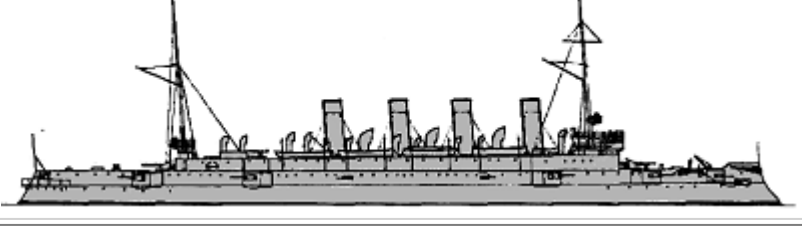
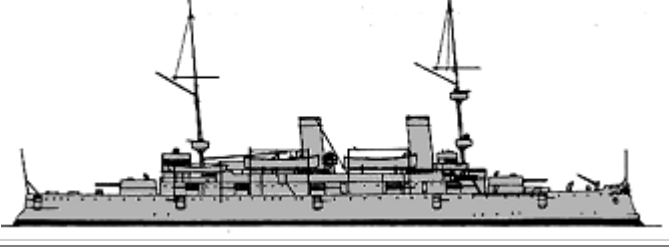

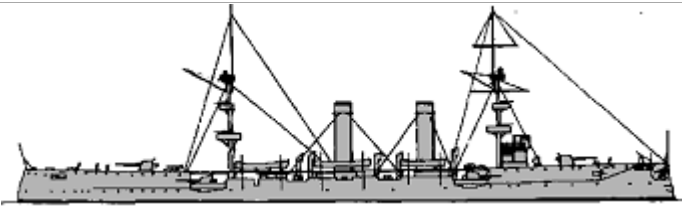
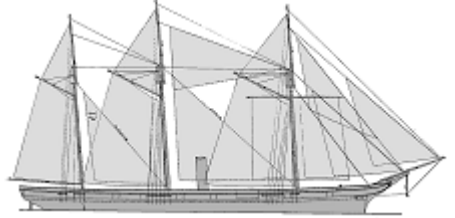

CA	New York	1	1	ACR2	New York	1893		9021t, 117.0x19.8x7.3m, 8b,2vte, 16000hp, 20kts, 566p; nickel steel: 102belt, 152deck, 140gunhouses, 190CT; (2x2+2x1)-203/37, 12x1-102/40, 8x1-57/45, 4x1-37/40, 3-356TT
	Brooklyn	1	2	ACR3	Brooklyn	1896		10068t, 122.7x19.7x7.3m, 7b,2vte, 16000hp, 20kts, 581p; Harvey and nickel steel: 4x2-203/37, 12x1-127/40, 12x1-57/45, 4x1-37/40, 5-450TT
	Hartford	1	1		Hartford (TS)	1859		2550t, 68.6ppx13.4x7.1m, 2b,1vce, 696hp, 9.5kts, 310p; 16x1-229/15, 1x1-203/15, 13x1-127/40
	Lancaster	1	2		Lancaster (TS)	1859		3290t, 71.8ppx14.0x6.8m, 2b,1hda, 810hp, 9.5kts, 310p; 2x1-279/15, 10x1-203/15, 2x1-107/24



						
Pensacola	1	3	Pensacola (TS)	1861		3000t, 70.3ppx13.6x5.7m, 4b,1hrccr, 8.5kts, 300p; 1x1-279/15, 22x1-229/15, 1x1-163/22
Galena	1	4	Mohican (TS)	1885		1900t, 65.8ppx11.3x5.0m, 10b,1hrccr, 800hp, 11kts, 230p; 6x1-229/15, 1x1-135/21
Atlanta	2	5	Atlanta	1886		3189t, 86.3x12.8x5.2m, 8b,1hce, 3500hp, 13kts, 284p; steel: 38deck, 51barbettes; 2x1-203/31, 6x1-152/30, 2x1-57/40, 2x1-47/40, 2x1-37/20
		6	Boston	1887		
Chicago	1	7	Chicago	1889		5000t, 104.3x14.7x5.8m, 10b,2hte, 9000hp, 18kts, 471p; steel: 29belt, 38deck, 25battery, 76CT; 4x1-203/37, 14x1-127/40, 2x1-57/40, 2x1-37/20
Baltimore	1	8	C3 Baltimore	1890		5436t, 102.1x14.8x5.9m, 4b,2hte, 10750hp, 19kts, 386p; steel: 102slopes, 64deck, 76CT; 4x1-203/31, 6x1-152/30, 4x1-57/40, 2x1-47/40, 2x1-37/20
CL Philadelphia	1	9	C4 Philadelphia	1890		5305t, 102.1x14.8x5.8m, 4b,2hte, 9000hp, 19kts, 384p; steel: 102slopes, 64deck, 76CT; 12x1-152/30, 4x1-57/40, 4x1-47/40, 2x1-37/20

							
San Francisco	1	10	C5	San Francisco	1890		4583t, 98.9x15.0x5.7m, 4b,2hte, 10500hp, 19kts, 384p; steel: 76slopes, 51deck, 76CT; 12x1-152/30, 4x1-57/40, 4x1-47/40, 2x1-37/20
Newark	1	11	C1	Newark	1891		4592t, 100.0x15.0x5.7m, 4b,2hte, 8500hp, 18kts, 384p; steel: 76slopes, 51deck, 76CT; 12x1-152/30, 4x1-57/40, 4x1-47/40, 2x1-37/20
Montgomery	3	12	C9	Montgomery	1894		2235t, 82.1x11.3x4.4m, 6b,2vte, 5400hp, 17kts, 274p; steel: 13slopes, 13deck, 51CT; 9x1-127/40, 6x1-57/45, 2x1-37/40
		13	C10	Detroit	1893		
		14	C11	Marblehead	1894		
Cincinnati	2	15	C7	Cincinnati	1894		3339t, 93.2x12.8x5.5m, 6b,2vte, 10000hp, 19kts, 322p; steel: 64slopes, 25deck, 102shields, 51CT; 1x1-152/41, 10x1-127/40, 8x1-57/45, 2x1-37/40(15), 4x1-37/40(16), 4-450TT
		16	C8	Raleigh	1894		
Columbia	2	17	C12	Columbia	1894		8270t, 125.9x17.7x6.9m, 8b,3vte, 21000hp, 21kts, 477p; steel: 102slopes, 64deck, 102casemates, 127CT; 1x1-203/40, 2x1-152/40, 8x1-102/40, 12x1-57/45, 4x1-37/40, 4-450TT(18), 4-356TT(17)
		18	C13	Minneapolis	1894		
Olympia	1	19	C6	Olympia	1895		6558t, 104.9x16.2x6.6m, 6b,2vte, 13500hp, 20kts, 447p; Harvey: 121slopes, 51deck, 89turrets, 127CT; 2x2-203/37, 10x1-127/40, 14x1-57/45, 6x1-37/40, 6-450TT

	New Orleans	1	20		New Orleans	1898		4011t, 108.0x13.3x5.5m, 4b,2vte, 7500hp, 20kts, 366p; 89slopes, 32deck, 102CT; 6x1-152/50, 4x1-120/50, 10x1-57/40, 8x1-37/20, 3-450TT	
SL	Alert	1			Alert	1875		1020t, 53.3ppx9.8x3.9m, 5b,1hcr, 380hp, 10kts, 148p; 1x1-279/15(1), 2x1-229/15(1), 1x1-135/21, 4x1-37/20(1)	
		2			Ranger	1876			
	Enterprise	3			Adams	1876			1375t, 56.4ppx10.7x4.4m, 8b,1hcr, 700-800hp, 10-11kts, 178-193p; 4x1-229/15, 1x1-203/18, 1x1-135/21, 4x1-37/20
		4			Alliance	1877			
		5			Essex (TS)	1876			
AMC -		1			Badger	1889		4784t, 100.5x12.8x5.6m, 1vte, 3200hp, 16kts; 6x1-127/40, 6x1-47/40	
		2			Buffalo	1892		6888t, 123.8x14.7x6.7m, 1vte, 3600hp, 14.5kts; 2x1-127/40, 4x1-102/40, 6x1-57/40	
		3			Dixie	1893		6114t, 119.3x14.7x6.1m, 1vte, 3800hp, 16kts; 10x1-152/30, 6x1-57/40	
		4			Panther	1889		4260t, 98.9x12.3x5.6m, 1vte, 3200hp, 13kts; 6x1-127/40, 2x1-102/40, 6x1-47/40	
		5			Prairie	1890		6872t, 123.4x14.7x6.7m, 1vte, 3800hp, 14.5kts; 10x1-152/30, 6x1-57/40	
		6			Yankee	1892		6888t, 123.8x14.7x6.7m, 1vte, 3800hp, 14.5kts; 10x1-127/40, 6x1-57/40	
		7			Yosemite	1892		6179t, 119.3x14.7x6.1m, 1vte, 3800hp, 16kts; 10x1-127/40, 6x1-57/40	

TORPEDO SHIPS

DD	Farragut	1	1	TB11	Farragut	1899		279t, 65.2x6.3x1.8m, 3b,2vte, 5878hp, 30kts, 66p; 4x1-57/50, 2x1-450TT	
TB	Stiletto	1	1	WTB1	Stiletto	1887	No picture	31t, 28.6x3.5x0.9m, 1b,1vc, 359hp, 18.2kts, 6p; 2Howel torps	
	Cushing	1	2	TB1	Cushing	1890		116t, 42.7x4.6x1.5m, 2b,2vqe, 1600hp, 23kts, 22p; 3x1-57/40, (1+2x1)-450TT	
	Ericsson	1	3	TB2	Ericsson	1897		120t, 45.6x4.7x1.5m, 2b,2vqe, 1800hp, 24kts, 22p; 4x1-37/40, (1+2x1)-450TT	
	Foote		4		TB3	Foote	1897		142t, 48.8x4.9x1.5m, 2b,2vte, 2000hp, 25kts, 20p; 3x1-37/40, 3x1-450TT
			5		TB4	Rodgers	1898		
			6		TB5	Winslow	1897		
	Porter		7		TB6	Porter	1897		165t, 53.5x5.4x1.4m, 3b,2vqe, 3200hp, 27.5kts, 24p; 4x1-37/40, 3x1-450TT
			8		TB7	DuPont	1897		
	Morris	1	9		TB14	Morris	1898		105t, 42.5x4.7x1.2m, 2b,2vte, 1750hp, 23kts, 26p; 3x1-37/40, 3x1-450TT
Talbot	2	10, 11		TB15, 16	Talbot, Gwin	1898	No picture	46t, 30.5x3.8x1.0m, 1b,1vte, 850hp, 20kts, 12p; 1x1-37/40, 2x1-450TT	
Mackenzie	2	12, 13		TB17, 18	Mackenzie, McKee	1898-1899	No picture	65t, 30.9x3.9x1.3m, 2b,1vte, 850hp, 20kts, 12p; 1x1-37/40(13), 2x1-37/40(14), 2x1-450TT	





Somers	1	14	TB22	Somers	1898	No picture	143t, 47.6x5.3x1.8m, 1b,1vqe, 1700hp, 23kts, 24p; 4x1-37/40, (1+2x1)-450TT
Rowan	1	15	TB8	Rowan	1899		182t, 51.8x5.2x1.8m, 3b,2vqe, 3200hp, 26kts, 24p; 4x1-37/40, 3x1-450TT
Davis	2	16	TB12	Davis	1899		155t, 45.1x4.7x1.8m, 2b,2vte, 1750hp, 23kts, 24p; 3x1-37/40, 3x1-450TT
		17	TB13	Fox	1899		

ESCORTS

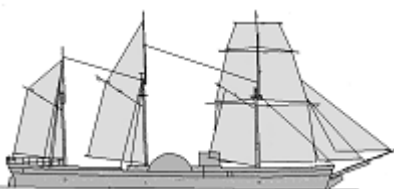
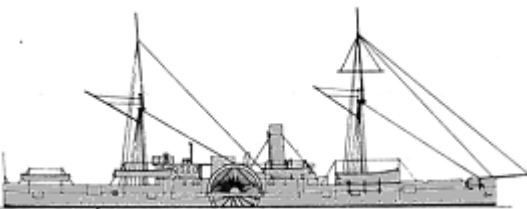
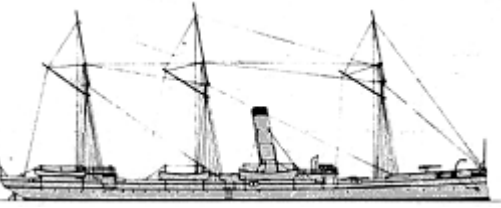
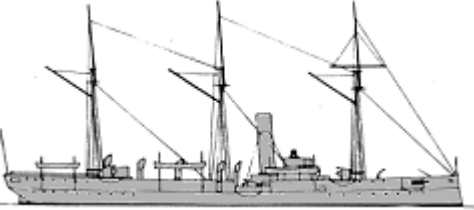
AY	-	9	1	Mayflower	1896	2690t, 83.2x11.0x5.3m, 2vte, 4700hp, 16.8kts; 2x1-127/40, 12x1-57/40
			2	Dorothea	1897	594t
			3	Eagle	1890	850t
			4	Gloucester	1891	786t
			5	Hawk	1891	545t
			6	Hornet	1890	425t
			7	Scorpion	1896	850t
			8	Vixen	1896	806t
			9	Wasp	1898	630t

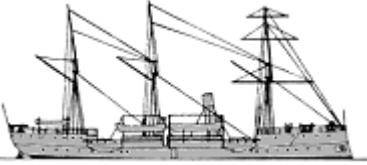
OTHER FIGHTING SHIPS

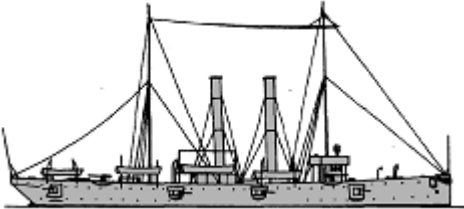
Michigan	1	1		Michigan	1844		686t, 49.5ppx8.2x3.7m, 1b,1dse(sw), 110hp, 12kts, 148p; 6x1-47/40
Mohongo	1	2		Monocacy	1866		1370t, 77.7wlx10.7x2.7m, 2b,1hda(sw), 850hp, 12kts, 190p; 4x1-203/14, 2x1-135/21, 4x1-47/40, 4x1-37/20
Dolphin	1	3		Dolphin	1884		1486t, 78.2x9.8x4.4m, 4b,1vc, 2255hp, 16kts, 152p; 1x1-152/30, 2x1-57/40, 4x5-37/20
Yorktown	3	4	PG1	Yorktown	1889		1921t, 74.5x11.0x4.3m, 4b,2hte, 3400hp, 16kts, 187-201p; 51CT; 6x1-152/30(4), 6x1-152/35(5,6), 2x1-57/40(4,5), 4x1-57/40(6), 2x1-47/40(4,5), 2x1-37/40(4,5), 4x1-37/40(6)
		5	PG3	Concord	1889		
		6	PG4	Bennington	1891		

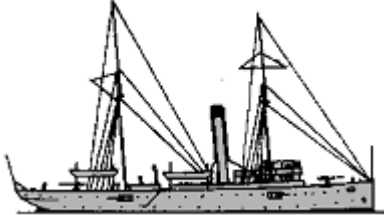
PG	Petrel	1	7	PG2	Petrel	1889		867t, 57.3x9.4x3.5m, 4b,1hce, 1000hp, 11.4kts, 138p; 4x1-152/35, 2x1-47/40, 1x1-37/40, 2x5-37/20
	Bancroft	1	8		Bancroft	1893	No picture	839t, 57.6x9.8x3.7m, 2b,2vte, 1200hp, 14.5kts, 148p; 4x1-102/40, 8x1-47/40, 1x1-37/40
	Machias	2	9	PG5	Machias	1893		1318t, 62.2x9.8x3.7m, 2b,2vte, 1900hp, 15.5kts, 154p; 8x1-102/40, 4x1-57/50(9), 6x1-57/50(10), 4x1-37/40
			10	PG6	Castine	1894		
	Nashville	1	11	PG7	Nashville	1897		1719t, 71.2x11.6x3.4m, 2b,2vqe, 2530hp, 16.3kts, 180p; 64sponsons; 8x1-102/40, 4x1-57/50, 2x1-37/40
	Wilmington	2	12	PG8	Wilmington	1897		1689t, 76.4x12.5x2.7m, 6b,2vte, 1900hp, 15kts, 183-199p; 25belt, 38deck, 8x1-102/40, 4x1-57/50, 4x1-37/40
			13	PG9	Helena	1897		
	Annapolis	4	14	PG10	Annapolis	1897	No picture	1000-1153t, 62.3x11.0x3.7-3.9m, 2b,1vte, 1000hp, 11-13kts, 135-156p; 6x1-102/40, 4x1-57/50, 2x1-37/40
			15	PG11	Vicksburgh	1897		
			16	PG12	Newport	1897		
			17	PG13	Princeton	1898		
	Wheeling	2	18	PG14	Wheeling	1897		1170t, 57.8x10.4x3.7m, 2b,2vte, 1050hp, 13kts, 140p; 6x1-102/40, 4x1-57/50, 2x1-37/40
			19	PG15	Marietta	1897		
	Alvorado	2	20		Alvorado	1895	No picture	106t, 33.6x4.7x1.6m, 1b,1vc, 137hp, 12kts, 33p; 1x1-57/50(20), 2x1-47/45(21), 1x1-37/40(20)
			21		Sandoval	1895		
	Callao	4	22	PG37	Callao	1889	No picture	243t, 34.8x5.3x2.0m, 1b,2vc, 275hp, 10-10.5kts, 35p; 1x1-57/50(23-25), 4x1-47/45(22), 3x1-47/45(23,24), 1x1-47/45(25), 2x1-37/40(22,24,25)
			23	PG39	Pampanga	1889		
24				Paragua	1889			
25			PG41	Samar	1888			
Albay	2	26		Albay	1886	No picture	173t, 30.0x5.0x2.2m, 1b,2vc, 150(26)-120(27)hp, 9(26)-7.5(27)kts, 35p; 1x1-57/50(26), 1x1-47/45(27), 2x1-37/40	
		27		Calamianes	1888			
Manileno	4	28		Manileno	1885	No picture	1x1-57/50(28,31), 1x1-47/45(29,30), 2x1-37/40(28,29,31), 1x1-37/40(30)	
		29		Mariveles	1886			
		30		Mindoro	1886			

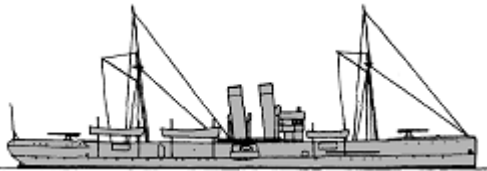
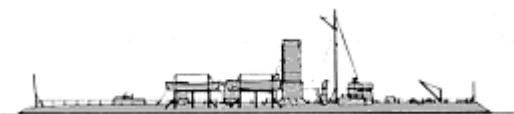
		31		Panay	1886		
APG	-	1	1	PG35 Topeka	1881		2372t, 76.2x10.7x5.4m, 4b,2hce, 2200hp, 16kts; 8x1-102/40, 2x1-57/50, 4x1-47/45, 2x1-37/40
RAM	Katahdin	1	1	Katahdin	1896		2383t, 76.4wlx13.2x4.6m, 3b,2hte, 5068hp, 16kts, 97p; Harvey: 152side, 152deck, 457CT; 4x1-57/45

COAST GUARD CUTTERS

CGC	Grant	1	1		U. S. Grant	1872	No picture	350t, 49.7x7.6x3.5m, 1b,1vte, 45p; 4x1-
	Manhattan	1	2		Manhattan	1873	No picture	147t, 31.1x6.2x2.6m, 1vce, 16p; 1x1-57/40
	Dallas	3	4		Dallas	1874	No picture	188(3,4)-300(5)t, 42.7(3,4)-53.4(5)x6.5(3,4)-7.9(5)x3.3(3,4)-3.8(5)m, 1b,1seidae(3,4)-1b,1vce(5), 275(3,4)-400(5)hp, 9.5kts, 40p; 2x1-57/40(3,4), 3x1-57/40(5)
					Dexter	1874		
					Rush	1874		
	Thomas Corwin	1	6		Thomas Corwin	1877	No picture	227t, 42.8x7.3x3.3m, 1b,1seidae, 41p; 3x1-
	Walter Forward	1	7		Walter Forward	1882	No picture	267t, 47.3x7.6x2.3m, 2vce, 38p; 2x1-
	Fessenden	1	8		Fessenden	1883	No picture	330t, 58.5x8.5x2.4m, 1vce(sw), 40p; 4x1-
	Commodore Perry	1	9		Commodore Perry	1884	No picture	282t, 50.3x7.6x3.4m, 1hdase, 41p; 2x1-
	Bear	1	10		Bear	1874	No picture	703t, 60.5x9.2x5.5m, 1b,1vce, 51p; 3x1-57/40
	Lot M. Morrill	1	11		Lot M. Morrill	1889	No picture	288t, 44.3x7.3x2.9m, 1b,1vce, 13kts, 38p; 1x1-76/50, 2x1-57/40
	Winona	1	12		Winona	1890	No picture	321t, 45.3x8.0x1.8m, 2vce, 600hp, 39p; 1x1-
	Galveston	1	13		Galveston	1891	No picture	708t, 57.9x8.8x2.8m, 2b,2vce, 1200hp, 12kts, 41p; 4x1-57/40
	William Windom	1	14		William Windom	1896	No picture	670t, 52.0x8.2x2.9m, 2b,2vte, 800hp, 15kts, 49p; 3x1-47/40
	Gresham	4	15	CG1	Gresham	1897	No picture	1190t, 62.6x9.8x3.4m, 4b,1vte, 2500hp, 17kts, 73p; 4x1-57/40
			16	CG2	Manning	1898		
17			CG4	Algonquin	1898			
18			CG5	Onondaga	1898			
McCulloch	1	19		McCulloch	1897	No picture	1280t, 66.8x10.2x4.3m, 2b,1vte, 17kts, 130p; 4x1-76/50, 1-450TT	
Thetis	1	20		Thetis	1881	No picture	1250t, 57.5x8.9x5.4m, 1vce; 3x1-47/40	

© Ivan Gogin, 2014

[home](#)[World navies yesterday](#)[1900](#)

Uruguay 01 January 1900

OTHER FIGHTING SHIPS

PG	General Artigas	1	1	General Artigas	1883	No picture	270t, 39.0x6.3x2.6m, 1hc, 520hp, 12.5kts; 2x1-120/27
	General Rivera	1	2	General Rivera	1884	No picture	300t, 35.9x6.3m, 360hp, 12kts, 75p; 1x1-149/27, 1x1-57/27
	Malvinas	1	3	Malvinas	1885	No picture	400t, 43.0x7.0x3.1m, 280hp, 8kts; 2x1-small guns
	General Suárez	1	4	General Suárez	1864	No picture	405t, 38.8x6.7x3.0m, 205hp, 9kts, 62p; 4x1-79/27
PGR	Maldonado	1	1	Maldonado	1886	No picture	300t, (stw), 12kts; 4x1-small guns

© Ivan Gogin, 2015

[home](#)[World navies yesterday](#)[1900](#)

Venezuela 01 January 1900

TORPEDO SHIPS

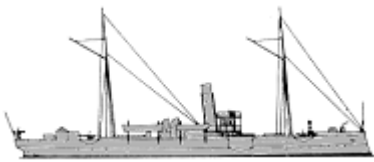
PGT	Bolívar	1	1	Bolívar	1894		630t, 58.0ppx6.7x3.2m, 4b,2vte, 2600hp, 19kts, 91p; steel- 13deck; 2x1-120/35, 4x1-57/42, 1x4-25/42, 2x1-356TT
-----	---------	---	---	---------	------	---	--

OTHER FIGHTING SHIPS

PG	Miranda	1	1	Miranda	1895	No picture	200t, 41.5x5.8x2.5m, 1b,1vte, 315hp, 10kts, 55p; 4x1-57/42
----	---------	---	---	---------	------	------------	--

© Ivan Gogin, 2015